

Wood-Mizer[®] Sawmill

Parts Manual

LT70 AC Remote

rev. A2.02



Safety is our #1 concern! Read and understand all safety information and instructions before operating, setting up or maintaining this machine.

December 2004

Form #997

Table of Contents

Section-Page

SECTION 1	GENERAL INFORMATION	1-1
1.1	How To Use The Parts List	1-1
1.2	Sample Assembly	1-1
SECTION 2	BLADE GUIDE ROLLERS & ARM	2-1
2.1	Blade Guide Assembly, Idle Side.....	2-1
2.2	Blade Guide Assembly, Drive Side	2-3
2.3	Blade Guide Arm Drive Assembly.....	2-5
SECTION 3	BLADE WHEELS & TENSIONER	3-1
3.1	Blade Drive Assembly.....	3-1
3.2	Idle Blade Wheel Assembly	3-3
3.3	Hydraulic Blade Tensioner Assembly.....	3-5
3.4	Sawdust Flow Guide.....	3-7
SECTION 4	SAW HEAD	4-1
4.1	Middle Throat Screw	4-1
4.2	Drive Belt Tensioner	4-2
4.3	Board Return Assembly (Optional).....	4-3
4.4	Water Lube Assembly	4-5
4.5	Saw Head Decals.....	4-6
4.6	Blade Housing Covers.....	4-7
4.7	Sawdust Chute	4-8
SECTION 5	CONTROL BOX	5-1
5.1	Control Assembly.....	5-1
5.2	Control Box Pedestal Assembly.....	5-3
5.3	Main Electric Box.....	5-5
SECTION 6	UP/DOWN SYSTEM	6-1
6.1	Up/Down Rollers & Covers	6-1
6.2	Up/Down Chain & Sprockets.....	6-3
6.3	Up/Down Drive Assembly	6-5
6.4	Sensor Assembly	6-7
SECTION 7	FEED SYSTEM & TRACK ROLLERS	7-1
7.1	Upper Track Rollers & Wipers.....	7-1
7.2	Feed Chain/Stop	7-3
7.3	Power Feed Assembly	7-5
7.4	Lower Track Rollers.....	7-6

Table of Contents

Section-Page

SECTION 8 BED FRAME ASSEMBLY

8-1

8.1	Bed Rails	8-1
8.3	Cable Carrier	8-3
8.4	Stationary Legs.....	8-4
8.5	Board Return Roller Assembly	8-6

SECTION 9 HYDRAULIC SYSTEM

9-1

9.1	Hydraulic Hoses, LT70 Remote	9-1
9.2	Hydraulic Control Box, LT70 Remote.....	9-3
9.4	Hydraulic Log Turner.....	9-7
9.5	Hydraulic Log Side Supports	9-9
9.6	Hydraulic Log Clamp	9-11
9.7	Hydraulic Log Clamp, Standard.....	9-13
9.8	Hydraulic Log Clamp, Optional.....	9-15
9.9	Hydraulic Toe Board	9-17

SECTION 1 GENERAL INFORMATION

1.1 How To Use The Parts List

- Use the index above to locate the assembly that contains the part you need.
- Go to the appropriate section and locate the part in the illustration.
- Use the number pointing to the part to locate the correct part number and description in the table.
- Parts shown indented under another part are included with that part.
- Parts marked with a diamond (◆) are only available in the assembly listed above the part.

See the sample table below. Sample Part #A01111 includes part F02222-2 and subassembly A03333. Subassembly A03333 includes part S04444-4 and subassembly K05555. The diamond (◆) indicates that S04444-4 is not available except in subassembly A03333. Subassembly K05555 includes parts M06666 and F07777-77. The diamond (◆) indicates M06666 is not available except in subassembly K05555.

1.2 Sample Assembly				
REF	DESCRIPTION (◆ Indicates Parts Available In Assemblies Only)	PART #	QTY.	
	Sample Assembly, Complete (Includes All Indented Parts Below)	A01111	1	
1	Sample Part	F02222-22	1	
	Sample Subassembly (Includes All Indented Parts Below)	A03333	1	
2	Sample Part (◆ Indicates Part Is Only Available With A03333)	S04444-4	1	◆
	Sample Subassembly (Includes All Indented Parts Below)	K05555	1	
3	Sample Part (◆ Indicates Part Is Only Available With K05555)	M06666	2	◆
4	Sample Part	F07777-77	1	

To Order Parts:

- From Europe call our European Headquarters and Manufacturing Facility in Kolo, Poland at **+48-63-2626000**. From the continental U.S., call our toll-free Parts hotline at **1-800-448-7881**. Have your customer number, vehicle identification number, and part numbers ready when you call.
- From other international locations, contact the Wood-Mizer distributor in your area for parts.

SECTION 2 BLADE GUIDE ROLLERS & ARM

2.1 Blade Guide Assembly, Idle Side

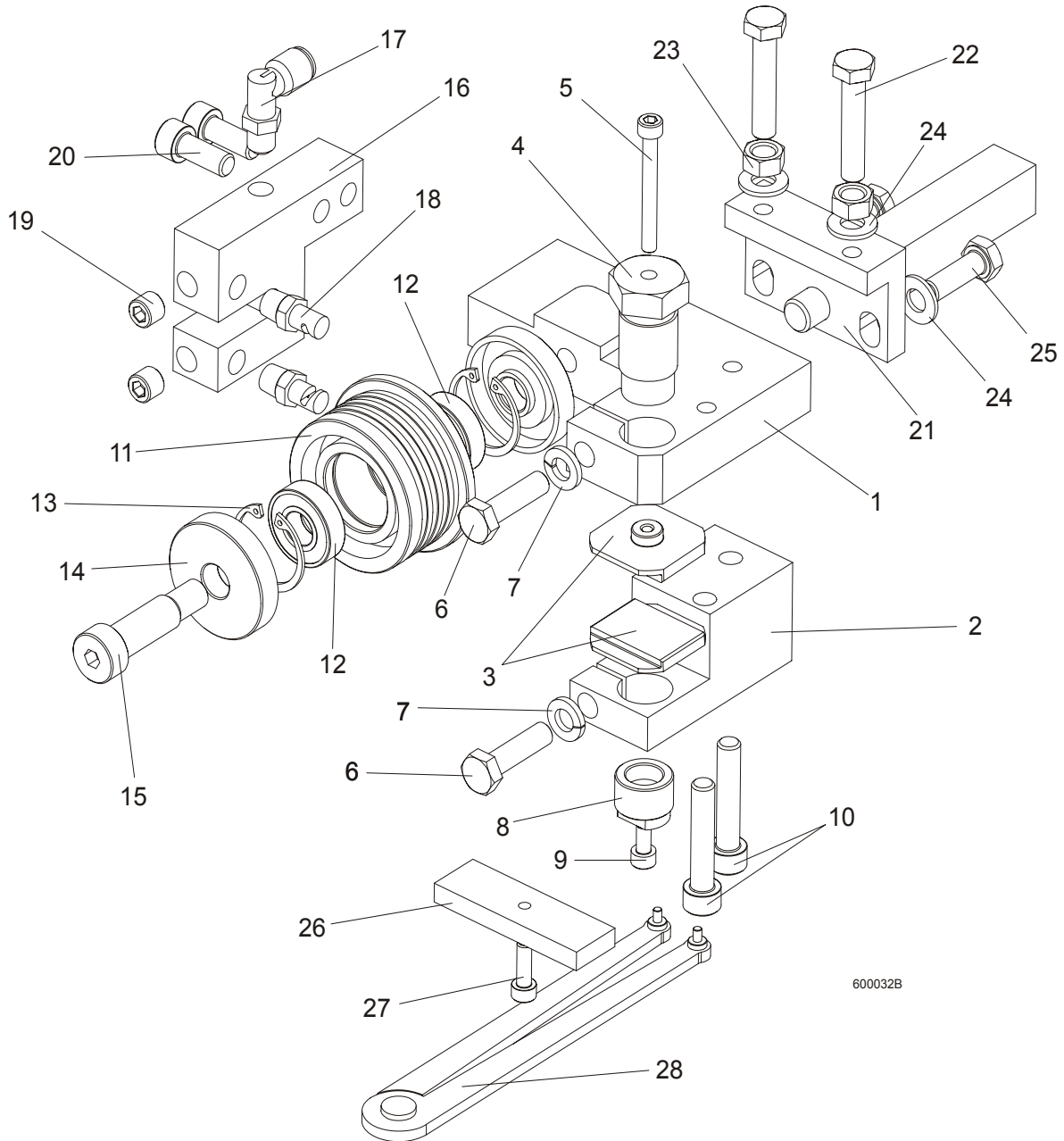

2 BLADE GUIDE ROLLERS & ARM

Blade Guide Assembly, Idle Side

REF	DESCRIPTION (u Indicates Parts Available In Assemblies Only)	PART #	QTY.	
	BLADE GUIDE ASSEMBLY, IDLE SIDE	090943	1	
	BLADE GUIDE W/EXTENDED ROLLER, COMPLETE IDLE SIDE (for optional use with 1 1/2" blades)	092997	1	
1	Block, Blade Guide Mount Zinc-plated	090947-1	1	
2	Block, Lower Block Mount Zinc-plated	090948-1	1	
3	Block, Blade Guide Zinc	093430-1	2	
4	Bolt, Upper Block Adjustment Zinc-plated	089515-1	1	
5	Screw, M5x45 DIN912 A2-70 Hex Socket Head Cap Stainless Steel	F81000-24	1	
6	Bolt, M8x30 DIN933 A2-70 Stainless Steel	F81002-27	2	
7	Washer, 8.2 Split Lock Zinc	F81054-4	2	
8	Screw, Lower Block Adjuster Zinc-plated	090945-1	1	
9	Screw, M5x10 DIN912 A2-70 Hex Socket Head Cap Stainless Steel	F81000-23	1	
10	Screw, M8x40-8.8 Hex Socket Head Cap Zinc	F81002-29	2	
	Roller, Blade Guide W/Bearing Narrow	088261	1	
	Roller, Blade Guide W/Bearing Extended	092939	1	
11	Roller, Blade Guide Narrow	087889	1	
12	Bearing, 6001 2RSR NACHI	087893	2	
13	Ring, W28 Inside Retaining	F81090-9	2	
14	Washer, Blade Guide Roller Spacer Zinc-plated	087891-1	2	
15	Screw, 12/M10x30 12.9 ISO 7379 Socket Head Shoulder	F81003-70	1	
	Screw, 12/M10x35 12.9 ISO 7379 Socket Head Shoulder (used with extended rollers only)	F81003-48	1	
16	Block, Nozzle Mounting Zinc-plated	090487-1	1	
17	Fitting, 90° Elbow 1/8NPT-1/4 Tube Swivel	P09736	1	
18	Nozzle, Blade Lube Spray	033479	2	
19	Plug, M10x1 DIN 906 BN40 "BOSSARD"	F81015-3	2	
20	Screw, M8x20-8.8 Hex Socket Head Cap Zinc	F81002-30	2	
21	Pivot Weldment, Blade Guide Zinc-plated	089509-1	1	
22	Bolt, M8x40 DIN933 A2-70 Stainless Steel	F81002-28	2	
23	Nut, M8 DIN934 A2-70 Stainless Steel	F81032-7	2	
24	Washer, 8.4 Zinc Flat	F81054-1	4	
25	Bolt, M8x25 DIN933 A2-70 Stainless Steel	F81002-26	2	
	Block, Blade Guide Alignment	090951	1	
26	Block, Blade Guide Alignment Zinc-plated	090805-1	1	
27	Screw, M5x16-8.8 Hex Socket Head Cap Zinc	F81000-25	1	
28	Spanner, 62860-3 (PERSCHMAN) Lower Block Adjustment	090949	1	

2.2 Blade Guide Assembly, Drive Side

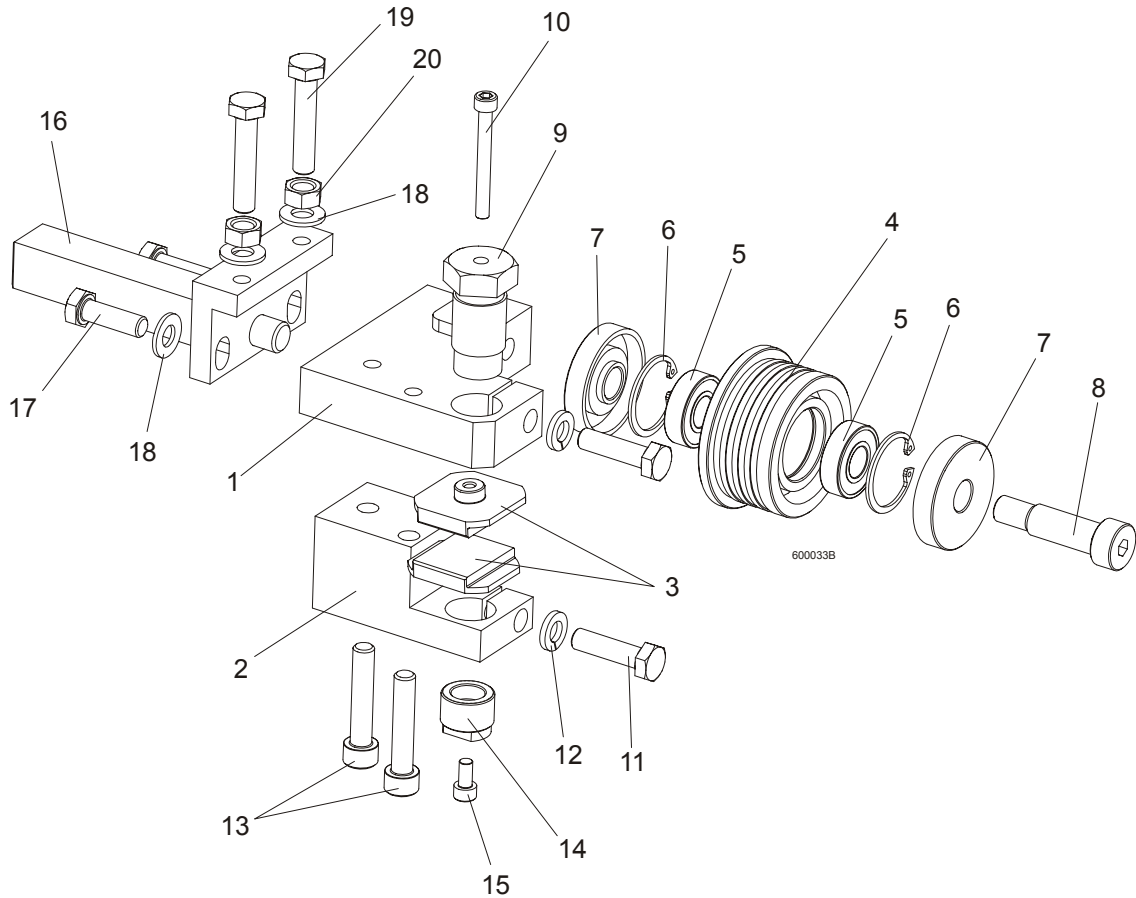

REF	DESCRIPTION (u Indicates Parts Available In Assemblies Only)	PART #	QTY.	
	BLADE GUIDE ASSEMBLY, DRIVE SIDE	090942	1	
	BLADE GUIDE, COMPLETE DRIVE SIDE W/EXTENDED ROLLER (FOR OPTIONAL USE WITH 1 1/2" BLADES)	092998	1	
1	Block, Blade Guide Mount Zinc-plated	090944-1	1	
2	Block, Lower Block Mount Zinc-plated	090946-1	1	
3	Block, Blade Guide Zinc	093430-1	2	
	Roller, Blade Guide Narrow W/Bearing	088261	1	
	Roller, Blade Guide Extended W/Bearing	092939	1	
4	Roller, Blade Guide Narrow	087889	1	
5	Bearing, 6001 2RSR NACHI	087893	2	◆
6	Ring, W28 Inside Retaining	F81090-9	2	
7	Washer, Blade Guide Roller Spacer Zinc-plated	087891	2	
8	Screw, 12/M10x30 12.9 ISO 7379 Socket Head Shoulder	F81003-70	1	
	Screw, 12/M10x35 12.9 ISO 7379 Socket Head Shoulder	F81003-48	1	
9	Bolt, Upper Block Adjustment	089515	1	

2 **BLADE GUIDE ROLLERS & ARM** *Blade Guide Assembly, Drive Side*

10	Screw, M5x45 DIN912 A2-70 Hex Socket Head Cap Stainless Steel	F81000-24	1	
11	Bolt, M8x30 DIN933 A2-70 Stainless Steel	F81002-27	2	
12	Washer, 8.2 Split Lock Zinc	F81054-4	2	
13	Screw, M8x40-8.8 Hex Socket Head Cap Zinc	F81002-29	2	
14	Screw, Lower Pad Adjustment Zinc-plated	090945-1	1	
15	Screw, M5x10 DIN912 A2-70 Hex Socket Head Cap Stainless Steel	F81000-23	1	
16	Pivot Weldment, Blade Guide Zinc-plated	089509-1	1	
17	Bolt, M8x25 DIN933 A2-70 Stainless Steel	F81002-26	2	
18	Washer, 8.4 Zinc Flat	F81054-1	4	
19	Bolt, M8x40 DIN933 A2-70 Stainless Steel	F81002-28	2	
20	Nut, M8 DIN934 A2-70 Stainless Steel	F81032-7	2	

2.3 Blade Guide Arm Drive Assembly

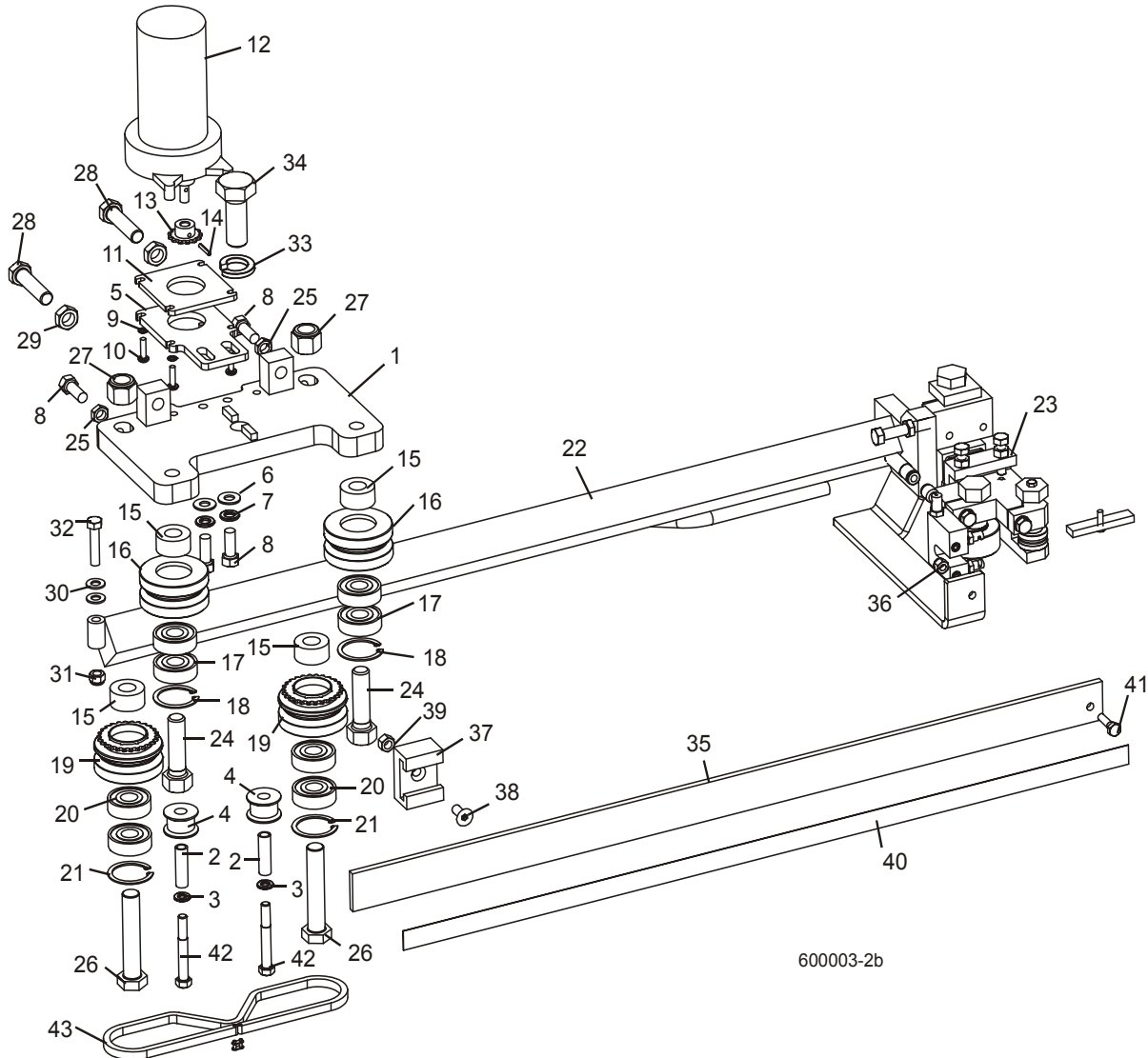

REF	DESCRIPTION (u Indicates Parts Available In Assemblies Only)	PART #	QTY.
	BLADE GUIDE ARM ASSEMBLY	090950	1
1	Plate Weldment, Blade Guide Arm Zinc-plated	090800-1	1
2	Bushing, .322 x .44 x 1 1/2" Spacer	S09996	2
3	Washer, 5/16" Split Lock Zinc	F05011-13	2
4	Roller, Chain Guide	090801	2
5	Plate, Blade Guide Motor Mount Painted	090803-1	1
6	Washer, 10.5 Zinc Flat	F81055-1	2
7	Washer, 3/8" Zinc Flat	F05011-4	2
8	Bolt, M10 x 25 8.8 Hex Head Full Thread	F81003-31	4

2

BLADE GUIDE ROLLERS & ARM

Blade Guide Arm Drive Assembly

9	Washer, 5.3 Zinc Flat	F81052-1	4	
10	Screw, #10-32 x 3/4 CrS1 Phillips Head	F05004-38	4	
11	Plate, Spacer Painted	090802-1	1	
12	Motor, 53:1 Gear ASA Blade Guide Arm	P09698-1	1	
13	Sprocket, 25B13 x .3130	P09970	1	
14	Pin, 3 x 14 Zinc Roll	F81044-4	1	
15	Spacer, Drive Roller Zinc-plated	090804-1	4	
	ROLLER ASSEMBLY, BLADE GUIDE ARM IDLER	042543	2	
16	Housing, 2 1/2" V-Groove	042536	1	
17	Bearing, 6203-2NSL 5/8	P06030-1	2	
18	Ring, 1.575" ID 5002-156 Retaining	F04254-8	1	
	ROLLER ASSEMBLY, BLADE GUIDE ARM DRIVE	042542	2	
19	Housing, 2 1/2" V-Groove W/Sprocket	042541	1	
20	Bearing, 6203-2NSL 5/8	P06030-1	2	
21	Ring, 1.575" ID 5002-156 Retaining	F04254-8	1	
22	Arm Weldment, Blade Guide Zinc-plated	090479-1	1	
23	Blade Guide Parts (See Section 2.1)			
24	Bolt, 5/8-18 x 3 1/4 Hex Head Grade 5	F05009-80	2	
25	Nut, M10-04-W Zinc Hex Thin	F81033-6	2	
26	Bolt, 5/8-18 x 3 1/4 Hex Head Grade 5	F05009-80	2	
27	Nut, 5/8-18 Hex Nylon Lock	F05010-71	2	
28	Screw, M12 x 1.25 x 60-33H Zinc Hex Set W/Full Dog Point	F81004-52	2	
29	Nut, M12 x 1.25 8.8 Zinc Hex Thin	F81034-5	2	
30	Washer, 8.4 Zinc Flat	F81054-1	1	
31	Nut, M8-8-B Hex Nylon Zinc Lock	F81032-2	1	
32	Bolt, M8 x 40-8.8 Hex Head Full Thread Zinc	F81002-15	1	
33	Washer, DIN 6319-21C Spherical	F81059-6	1	
34	Bolt, M20 x 1.5 x 50-8.8-B Hex Head Full Thread Zinc	F81007-2	1	
35	Guard, Blade	088306	1	
36	Nut, M6-8-B Hex Nylon Zinc Lock	F81031-2	1	
37	Guide, Blade Guard	088305	1	
38	Screw, M8 x 25 Cross Recessed Countersunk Head Zinc	F81002-51	1	
39	Nakrętka, M8-8-B-FeZn5 Z WKL.PN-M/82175	F81032-2	1	
40	Decal, Warning	015849	1	
41	Bolt, M6 x 20-8.8 Hex Head Full Thread Zinc	F81001-2	2	
42	Screw, 12/M10 x 20 12.9 ISO7379(BOSSARD) Socket Head Shoulder	F81003-68	2	
43	Chain, #25 x 92 PITCHES B/G	093805	1	

SECTION 3 BLADE WHEELS & TENSIONER

3.1 Blade Drive Assembly

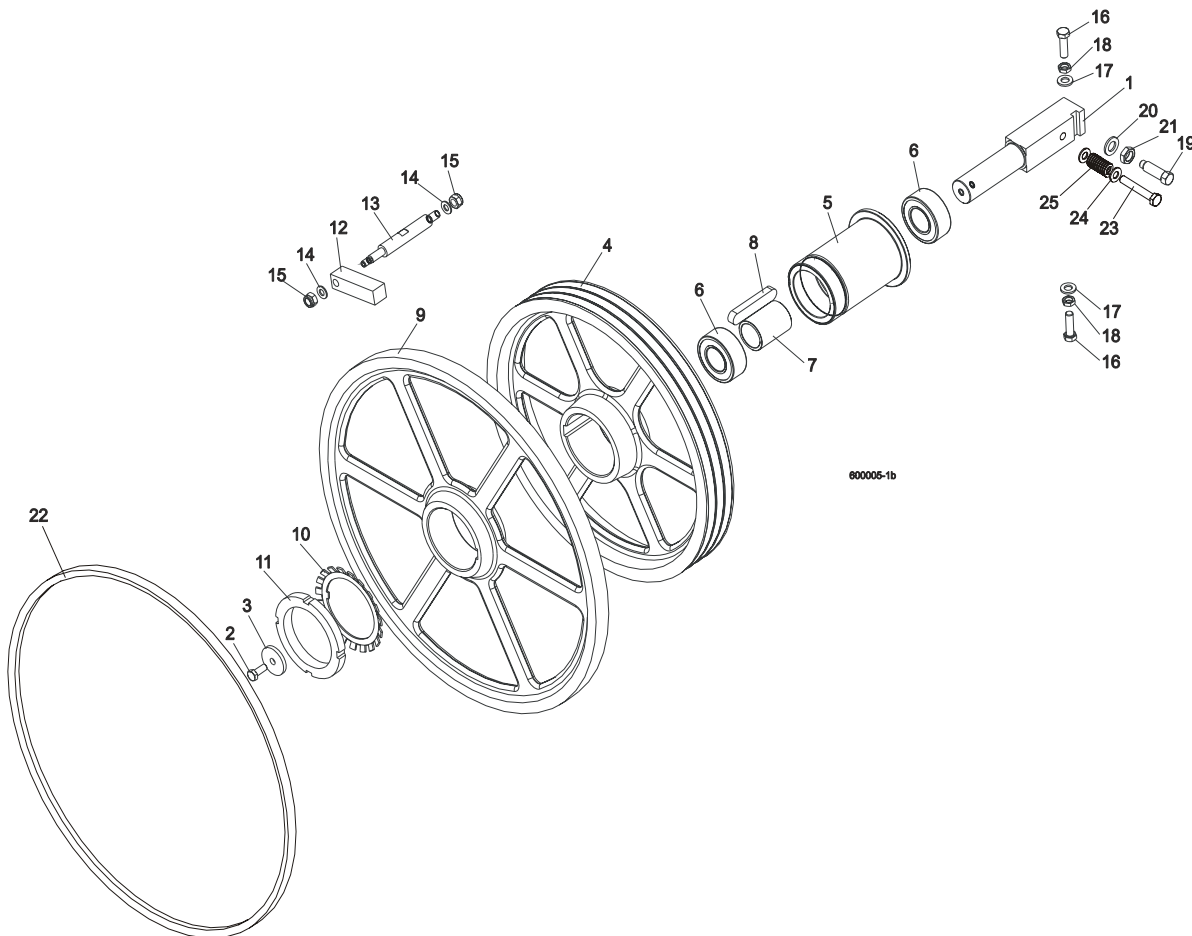

REF	DESCRIPTION (◆ Indicates Parts Available In Assemblies Only)	PART #	QTY.
1	SHAFT, BLADE DRIVE WHEEL	088475	1
2	BOLT, M10x25 8.8 HEX HEAD FULL THREAD	F81003-31	1
3	WASHER, BLADE DRIVE WHEEL ZINC-PLATED	088956-1	1
	PULLEY ASSEMBLY, BLADE DRIVE	088561	1
4	Pulley, 3-Groove 484 mm Diameter	089457-1	1
5	Bushing, Blade Drive Wheel	088476	1
6	Bearing, 3208.2rsr.tvh (FAG) Rolling	088449	2
7	Bushing, Spacer	088478	1
8	Key, A20x12x100 Parallel	088477	1
9	WHEEL, BLADE DRIVE	090811	1
10	WASHER, MB21 (FAG) LOCK	088451	1
11	NUT, KM21(M105X2) (FAG) LOCK	088450	1

3 BLADE WHEELS & TENSIONER

Blade Drive Assembly

12	BLOCK, DRIVE BLADE WHEEL SCRAPER	088781	1	
13	SHAFT, WHEEL SCRAPER LONG ZINC-PLATED	088780-1	1	
14	WASHER, 10.5 ZINC FLAT	F81055-1	2	
15	NUT, M12-8 HEX NYLON ZINC LOCK	F81034-2	2	
16	BOLT, M12X1.25X40 HEX HEAD	F81004-42	3	
17	WASHER, 13 FLAT ZINC	F81056-1	3	
18	NUT, M12X1.25 8.8 THIN ZINC	F81034-5	3	
19	SCREW, M16X1.5X50-33H HEX HEAD FULL DOG POINT SET ZINC	F81006-14	1	
20	WASHER, 17 ZINC FLAT	F81058-1	1	
21	NUT, M16x1.5-08-B ZINC THIN	F81036-6		
22	V-BELT, B72.5	017922	1	
23	BOLT, M10X65-8.8-B HEX HEAD ZINC	F81003-67	1	
24	WASHER, 10.5 ZINC FLAT	F81055-1	2	
25	SPRING, 19X38 COMPRESSION	034430	1	

3.2 Idle Blade Wheel Assembly

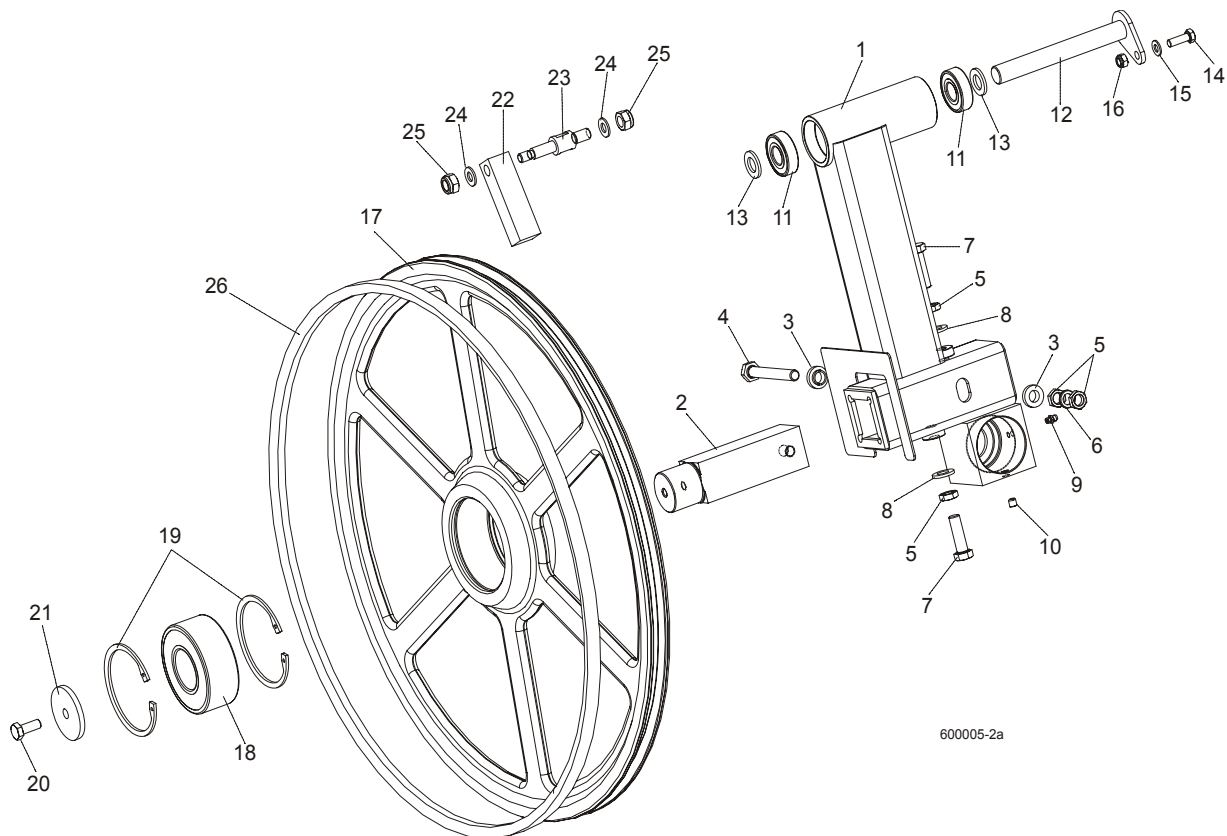

600005-2a

REF	DESCRIPTION (◆ Indicates Parts Available In Assemblies Only)	PART #	QTY.
	TUBE WELDMENT, IDLE SIDE BLADE WHEEL COMPLETE	088762	1
1	Tube Weldment, Idle Blade Wheel	088434-1	1
2	Shaft, Idle Blade Wheel	088474	1
3	Washer, Zinc Special	086769-1	2
4	Bolt, M12x1.25x100-8.8 Hex Head Zinc	F81004-41	1
5	Nut, M12x1.25 8.8 Hex Thin Zinc	F81034-5	4
6	Washer, Z12.2 Split Zinc Lock	F81056-2	1
7	Bolt, M12x1.25x40 Hex Head	F81004-42	2
8	Washer, 13 Zinc Flat	F81056-1	2
9	Fitting, M6 Straight Grease	086280	1
10	Screw, M8x8-33H Hex Socket Set Flat Point Zinc	F81014-1	1
11	Bearing, 6204 2RS-CX Rolling	088447	2
12	PIN WELDMENT, PIVOT	088759-1	1
13	WASHER, 17 ZINC FLAT	F81058-1	2
14	BOLT, M8X25-8.8-B HEX HEAD FULL THREAD ZINC	F81002-5	1
15	WASHER, 8.4 ZINC FLAT	F81054-1	1
16	NUT, M8-8-B HEX NYLON ZINC LOCK	F81032-2	1

3 BLADE WHEELS & TENSIONER

Idle Blade Wheel Assembly

	WHEEL ASSEMBLY, IDLE SIDE BLADE	088764	1	
17	Wheel, Idle Side Blade	090810	1	
18	Bearing, 3309B.2RSR.TVH-P66 FAG	086428	1	
19	Ring, W100 Inside Retaining	F81090-10	2	
20	BOLT, M10X25 8.8 HEX HEAD FULL THREAD	F81003-31	1	
21	WASHER, IDLE BLADE WHEEL RETAINING	088957-1	1	
22	BLOCK, IDLE BLADE WHEEL SCRAPER	088781	1	
23	SHAFT, WHEEL SCRAPER SHORT ZINC-PLATED	088779-1	1	
24	WASHER, 10.5 ZINC FLAT	F81055-1	2	
25	NUT, M12-8 HEX NYLON ZINC LOCK	F81034-2	2	
26	V-BELT, B72.5	017922	1	

3.3 Hydraulic Blade Tensioner Assembly

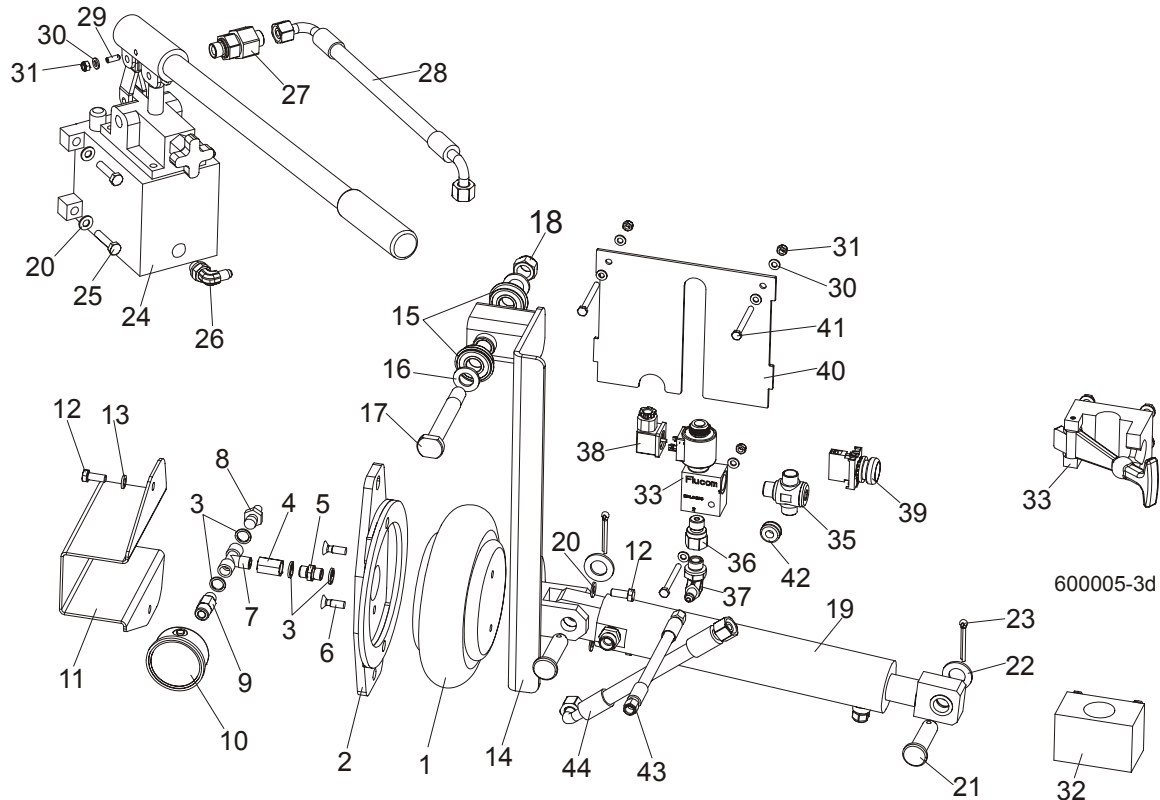

REF	DESCRIPTION (◆ Indicates Parts Available In Assemblies Only)	PART #	QTY.
	HYDRAULIC BLADE TENSIONER, COMPLETE	092775	1
1	Bag, POJ 192 308 100 0 Air	088576	1
2	Bracket, Air Bag Mount	088798-1	1
3	Seal, G1/4 866-014-000-0	090809	4
4	Fitting, 1/4 Female Thread/1/4 Female Thread 893-302-000-4	090808	1
5	Nipple, 1/4 Thread/1/4 Thread 893-104-430-4	090807	1
6	Wkręt z łbem stożk. M8x25 Fe/Zn5 PN-M/82208	F81002-51	2
7	Fitting, PO 2301 002 2 Tee Connector	088573	1
8	Fitting, 1/4" Thread 390 004 004 0 (REXROTH) Air Tank Valve	088575	1
9	Fitting, 1/8" Thread x 1/4" Thread	088571	1
10	Gauge, M63T-2,5/20G G 1/8 0-0,6 MPa/PSI Air Pressure	088568	1
11	Guard, Air Pressure Gauge	088924-1	1
12	Screw, M8x25 Cross Recessed Countersunk Head Zinc	F81002-4	4
13	Washer 8.2 Zinc Split	F81054-4	2
14	Ramię siłownika pneumatycznego mal.	092779-1	1
15	Bearing w/Snap Ring 6203-2RS	086395	2
16	Washer, M16, Flat Zinc	F81058-1	2
17	Pin, Idler Arm Mount	086404	1

18	Nut, M16, Hex, Nylon Zinc Lock	F81036-2	2	
19	Siłownik hydrauliczny kpl.	092788	1	
20	Washer, 8.4 Zinc Flat	F81054-1	6	
21	Sworzeń PN-EN 22341-B-18x65x57-A2	F81049-4	2	
22	Washer, 19 Fe/Zn5 PN-M/82005	F81060-1	2	
23	Pin, S-Zn 5x40 PN-M/82001	F81043-31	2	
24	Pompa ręczna PMS12/TNK1 z 1 litr. zbiorn.	092789	1	
25	Bolt, 8mm x 1.25x35mm HH Zinc	F81002-13	4	
26	Kolanko, CA-204410-3	094562	1	
27	Zawór zwrotny, RHV12LREDA3C	094559	1	
28	Wąż DN12 z końc. PN10AOL90 M18x1,5	094565	1	
29	Zatrask kulkowy gwint. GN615.3-M6-KN	096874	1	
30	Washer, M6, Flat, Zinc	F81053-1	7	
31	Nut, M6, Hex, Nylon Lock Zinc	F81031-2	4	
32	Uchwyt dolny dźwigni pompy napinacza	096951	1	
33	Górny uchwyt dźwigni pompy napinacza	092800	1	
34	Zawór ECP 20/22B2	094564	1	
35	Trójnik HD-TH-12L-BE-06	094560	1	
36	Złączka dławiąca, specjalna G 3/8	096849	1	
37	Kolanko, CA-204411-3	094563	1	
38	Złącze elektrozaworu 300.11.00	094555	1	
39	Przycisk monostabilny M22 płaski, zielony	094581	1	
40	Pokrywa elektrozaworu - mal.	094569-1	1	
41	Bolt, M6x60mm Hex Head, Zinc	F81001-9	3	
42	Grommet, Rubber 3/8 ID	025248	1	
43	Wąż 1/4 z końcówkami JIC 7/16-20	092806	1	
44	Wąż DN12 z końc. PN10AOL90 i PN10AOL M1.5	096964	1	

3.4 Sawdust Flow Guide

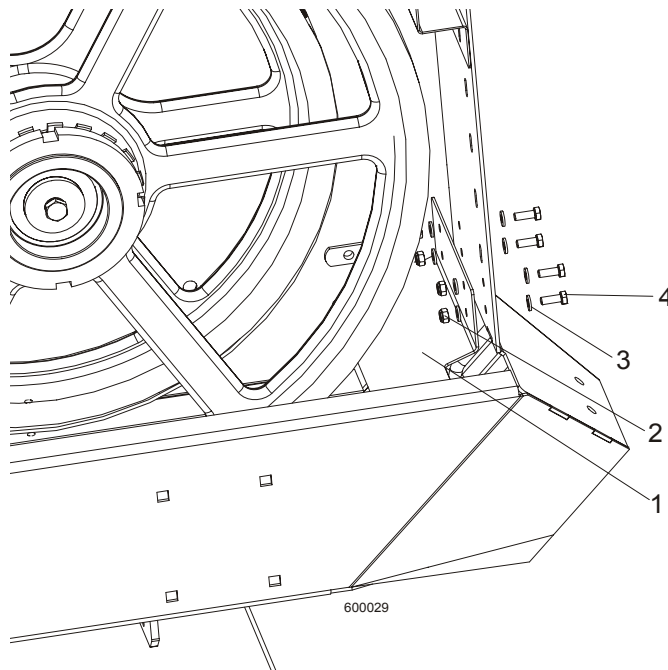

REF	DESCRIPTION (◆ Indicates Parts Available In Assemblies Only)	PART #	QTY.	
1	PLATE, SAWDUST FLOW GUIDE	090506	1	
2	NUT, M6-8-B HEX NYLON ZINC LOCK	F81031-2	4	
3	WASHER, 6.4 FLAT ZINC	F81053-1	8	
4	BOLT, M6x16-8.8 HEX HEAD FULL THREAD ZINC	F81001-32	4	

4 **SAW HEAD**
Middle Throat Screw

SECTION 4 SAW HEAD

4.1 Middle Throat Screw

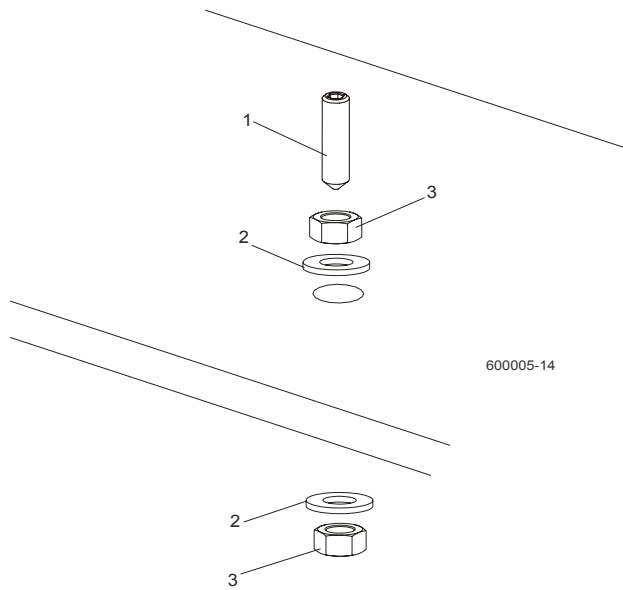

REF	DESCRIPTION (◆ Indicates Parts Available In Assemblies Only)	PART #	QTY.	
1	SCREW, M10X40-45H HEX SOCKET SET CONE POINT ZINC	F81003-61	1	
2	WASHER, 10.5 FLAT ZINC	F81055-1	2	
3	NUT, M10-8-B HEX ZINC	F81033-3	2	

4.2 Drive Belt Tensioner

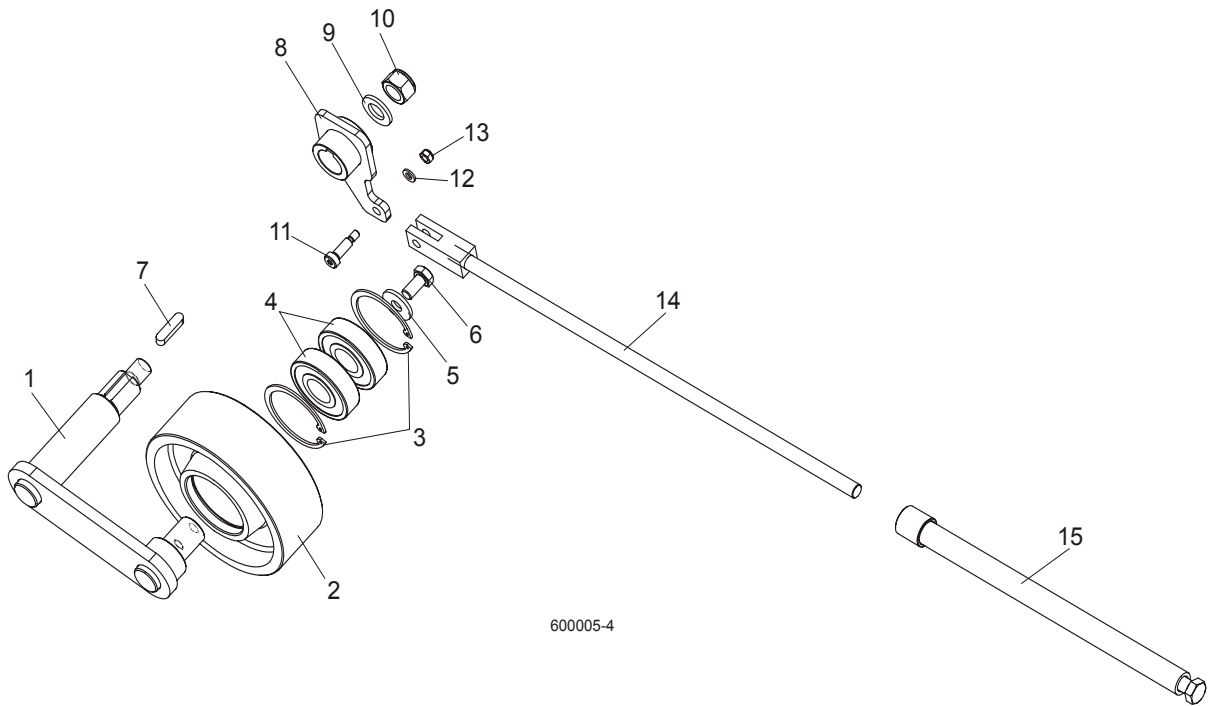

REF	DESCRIPTION (◆ Indicates Parts Available In Assemblies Only)	PART #	QTY.
	TENSIONER ASSEMBLY, DRIVE BELT	088786	1
1	Pivot Weldment, Drive Belt Tensioner	088810-1	1
2	Wheel, Belt Tension	088814	1
3	Ring, 62 mm Inside Retaining	F81090-1	2
4	Bearing, 6305 2RS NSK	P08066	2
5	Washer, 11 Dia. Special Flat Zinc	088787-1	1
6	Bolt, M10x20-5.8 Hex Head Full Thread Zinc	F81003-1	1
7	Key, A8X7X32 Parallel	088564	1
8	Arm Weldment, Drive Belt Tensioner	088807-1	1
9	Washer, 17 Flat Zinc	F81058-1	1
10	Nut, M16-5.8 Hex Zinc	F81036-1	1
11	Bolt, 8/M6X20 12.9 ISO 7379 BOSSARD Shoulder	F81001-25	1
12	Washer 6.4 Flat Zinc	F81053-1	1
13	Nut, M6-8-B Hex Nylon Zinc Lock	F81031-2	1
14	Rod Weldment, Threaded Zinc-plated	088789-1	1
15	Tube Weldment, Threaded Zinc-plated	088782-1	1

4 SAW HEAD

Board Return Assembly (Optional)

4.3 Board Return Assembly (Optional)

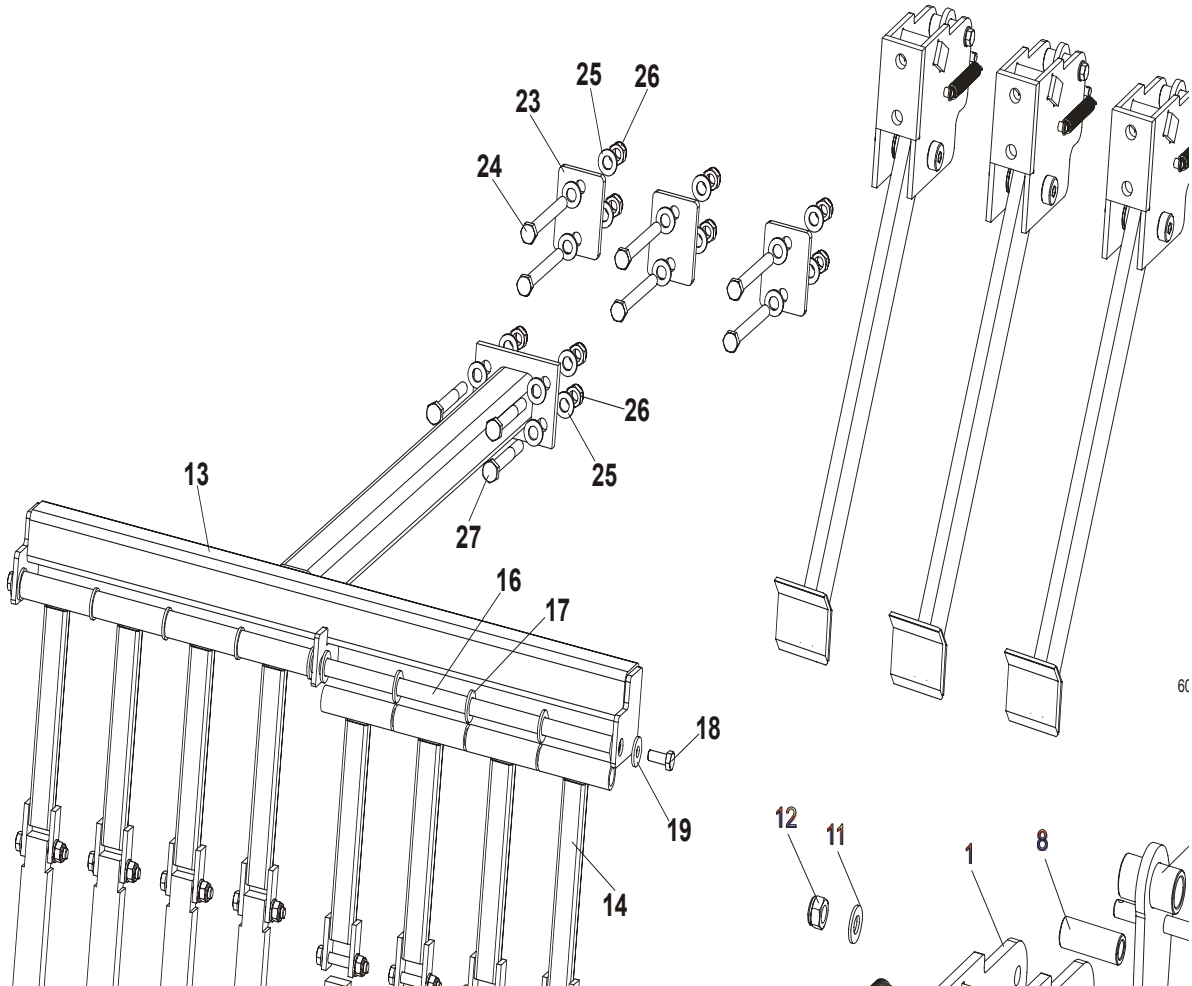

REF	DESCRIPTION (◆ Indicates Parts Available In Assemblies Only)	PART #	QTY.
	BOARD RETURN ASSEMBLY, LT70	092757	1
	Board Return Assembly	090120	3
1	Mount Weldment, Board Return Arm	090109-1	3
2	Arm, Board Return	090112-1	3
3	Bushing, Bronze	086676	6
4	Bolt, 16/M12x50-12.9 ISO7379-BOSSARD Socket Head	F81004-25	3
5	Washer, 13 Flat Zinc	F81056-1	3
6	Nut, M12-8 Hex Nylon Zinc Lock	F81034-2	6
7	Latch Weldment, Board Return Arm	090118-1	3
8	Spacer, Zinc-plated	090115-1	3
9	Spring, 1.6x12x38 Extension	092208	6
10	Bolt, M8 x 65-5.8 Hex Head Zinc	F81002-3	3
11	Washer, 8.4 Flat Zinc	F81054-1	6

12	Nut, M8-8-B Hex Nylon Zinc Lock	F81032-2	3	
	Guide, Board Return	091076	1	
13	Guide Weldment, Board Return	091067-1	1	
14	Bar Weldment, Board Guide Upper	091070-1	8	
15	Bar, Board Guide Lower Aluminium	091071	8	
16	Rod, Board Return Guide	091074	1	
17	Washer, 17 Flat Zinc	F81058-1	10	
18	Bolt, M10x25 8.8 Hex Head Full Thread	F81003-31	2	
19	Washer, 10.5 Special Flat Zinc	F81055-6	2	
20	Bolt, M10x60 -8.8 Hex Head Zinc	F81003-10	8	
21	Washer, 10.5 Flat Zinc	F81055-1	16	
22	Nut, M10-8-B Hex Nylon Zinc Lock	F81033-1	8	
23	Washer, Special	092756-1	3	
24	Bolt, M12x120 8.8 Hex Head Zinc	F81004-38	6	
25	Washer, 13 Flat Zinc	F81056-1	20	
26	Nut, M12-8 Hex Nylon Zinc Lock	F81034-2	10	
27	Bolt, M12x100-8.8 Hex Head Zinc	F81004-3	4	

4 SAW HEAD

Water Lube Assembly

4.4 Water Lube Assembly

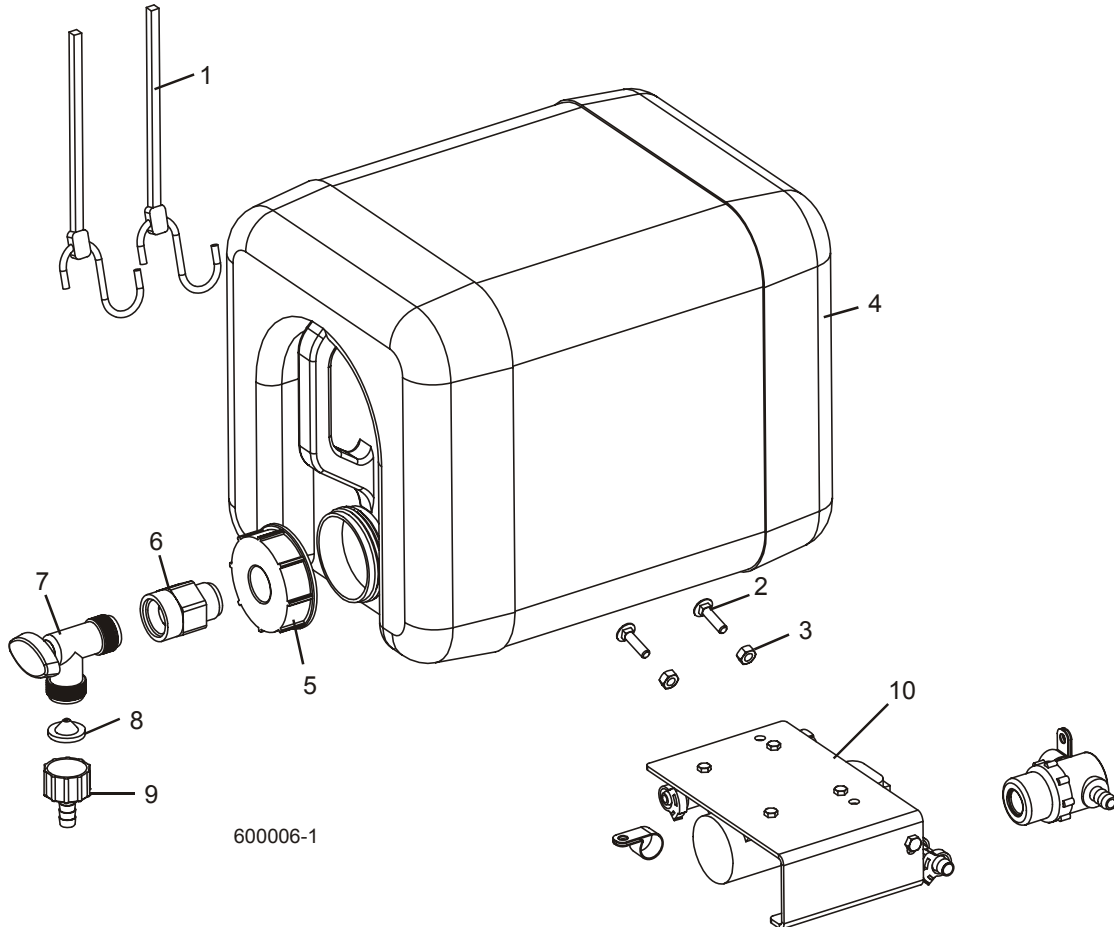

REF	DESCRIPTION (◆ Indicates Parts Available In Assemblies Only)	PART #	QTY.
1	STRAP, 20" RUBBER	P11668	2
2	BOLT, 1/4-20 X 1" CARRIAGE HEAD	F05005-34	2
3	NUT, 1/4-20 HEX LOCK	F05010-21	2
	BOTTLE ASSY, WATER LUBE	014642	1
4	Bottle, 5-Gallon (19 l) Water Lube	014637	1 ◆
5	Cap, Water Lube Bottle Buttress Thread	014773	1
6	FITTING, 3/4FPT X 3/4MPT	014636	1
7	FITTING, WATER LUBE SHUTOFF VALVE	014100	1
8	FILTER, WATER LUBE	016086	1
9	FITTING, 5/8" NPT TO 3/8" HOSE BARB	014113	1
10	LUBEMIZER PARTS/HOSES (SEE LUBEMIZER OPTION MANUAL)		

4.5 Saw Head Decals

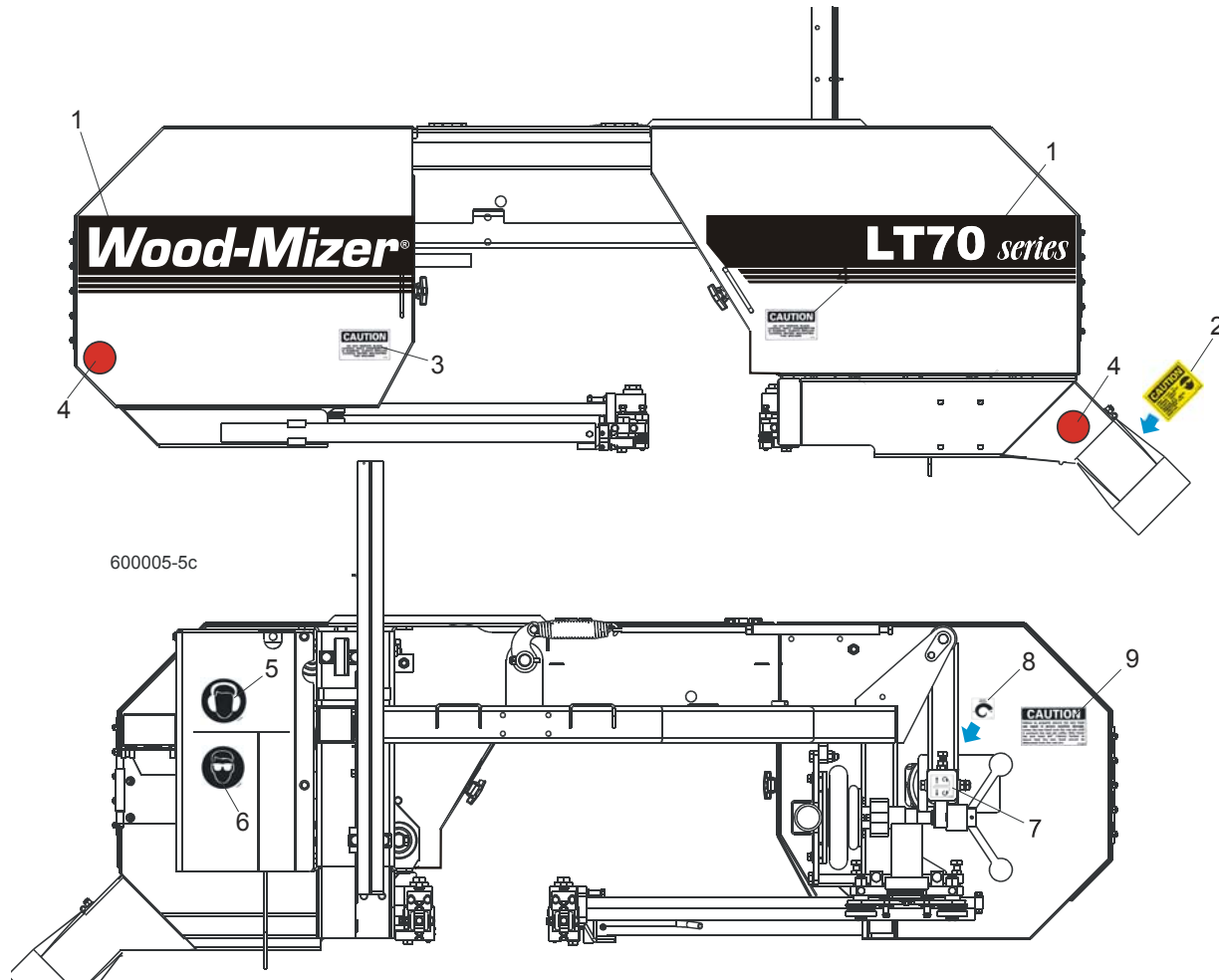

REF	DESCRIPTION (◆ Indicates Parts Available In Assemblies Only)	PART #	QTY.
1	DECAL, LT70 LOGO	092764	1
2	DECAL, SAWDUST CHUTE CAUTION	P11754	1
3	DECAL, BLADE COVERS DANGER	S20039	2
4	REFLECTOR, 2" RED	P07452	2
5	DECAL, EYE WARNING	S12004G	1
6	DECAL, EAR WARNING	S12005G	1
7	DECAL, BLADE ALIGNMENT	P11789	1
8	DECAL, BLADE TENSION SCREW	P11790	1
9	DECAL, SAW HEAD REST CAUTION	S12581	1

4 SAW HEAD

Blade Housing Covers

4.6 Blade Housing Covers

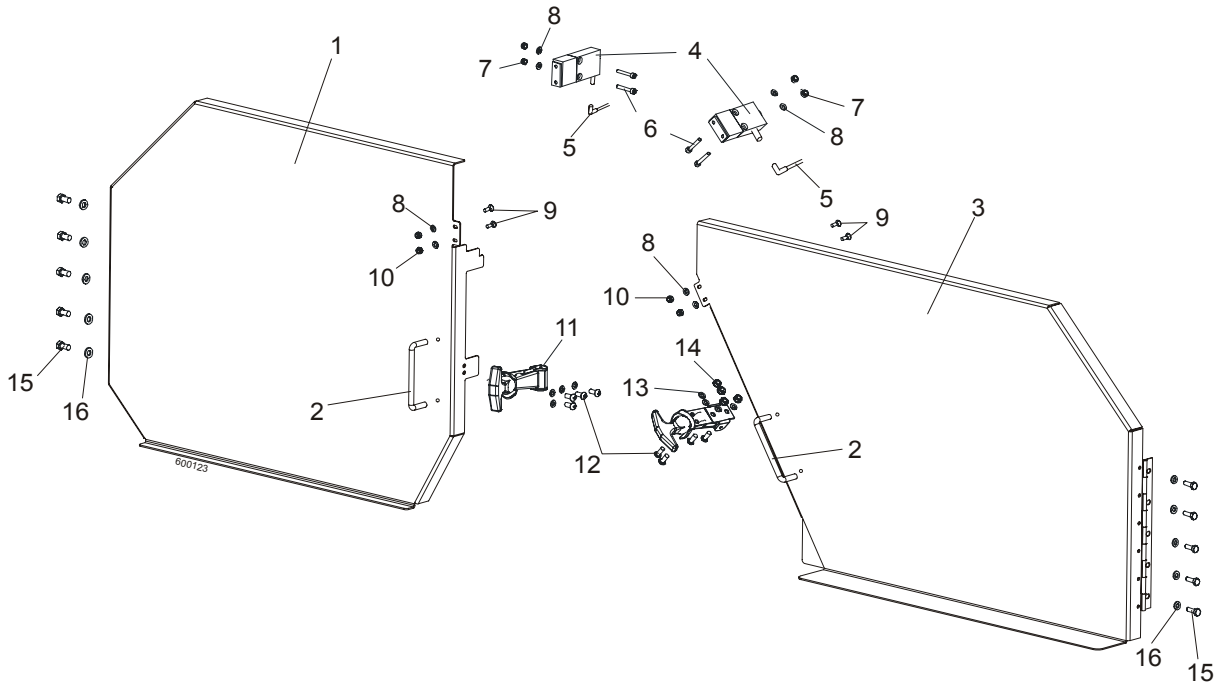

REF	DESCRIPTION (◆ Indicates Parts Available In Assemblies Only)	PART #	QTY.
	COVER ASSEMBLY, IDLE SIDE BLADE HOUSING	088920	1
1	Cover Weldment, Idle Side Blade Housing Painted	088915-1	1
2	Handle, Blade Housing Cover	P08065	1
	COVER ASSEMBLY, DRIVE SIDE BLADE HOUSING	088921	1
3	Cover Weldment, Drive Side Blade Housing Painted	088917-1	1
2	Handle, Blade Housing Cover	P08065	1
4	SWITCH, GKMB23W2 HONEYWELL SAFETY	086681	2
5	CABLE, 5m SAFETY SWITCH	087652	2
6	SCREW, M4x20 8.8 SOCKET HEAD CAP ZINC	F81011-31	4
7	NUT, M4-B HEX NYLON ZINC LOCK	F81029-1	4
8	WASHER, 4.3 FLAT ZINC	F81051-2	8
9	SCREW, M4x12 5.8-B SLOTTED COUNTERSUNK HEAD ZINC	F81011-41	4
10	NUT, M4-B HEX NYLON ZINC LOCK	F81029-1	4
11	LATCH, FLEXIBLE DRAW	014829	2
12	BOLT, M5x12-5.8 HEX HEAD FULL THREAD ZINC	F81000-5	8
13	WASHER, 5.3 FLAT ZINC	F81052-1	8
14	NUT, M5-8 DIN 985 ZINC-PLATED	F81030-2	8
15	BOLT, M6X16 8.8 HEX HEAD FULL THREAD ZINC	F81001-15	10
16	WASHER, 6.4 FLAT ZINC	F81053-1	10

4.7 Sawdust Chute

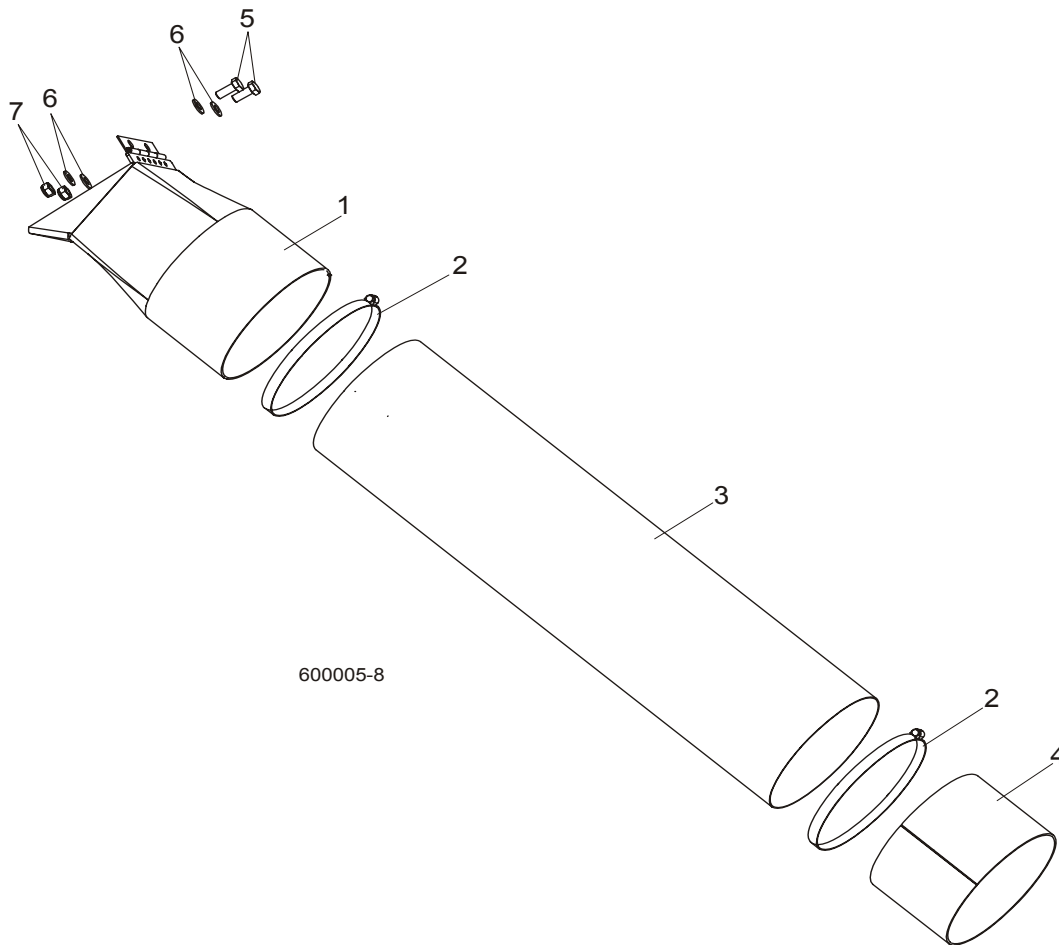

REF	DESCRIPTION (◆ Indicates Parts Available In Assemblies Only)	PART #	QTY.
1	CHUTE WELDMENT, SAWDUST	089352-1	1
2	CLAMP, 152MM DIA.	089358	2
3	TUBE, SAWDUST CHUTE	090153	1
4	TUBE, SAWDUST CHUTE END	090126-1	1
5	BOLT, M8X20-8.8-B HEX HEAD FULL THREAD ZINC	F81002-4	2
6	WASHER, 8.4 FLAT ZINC	F81054-1	4
7	NUT, M8-8-B HEX NYLON ZINC LOCK	F81032-2	2

SECTION 5 CONTROL BOX

5.1 Control Assembly

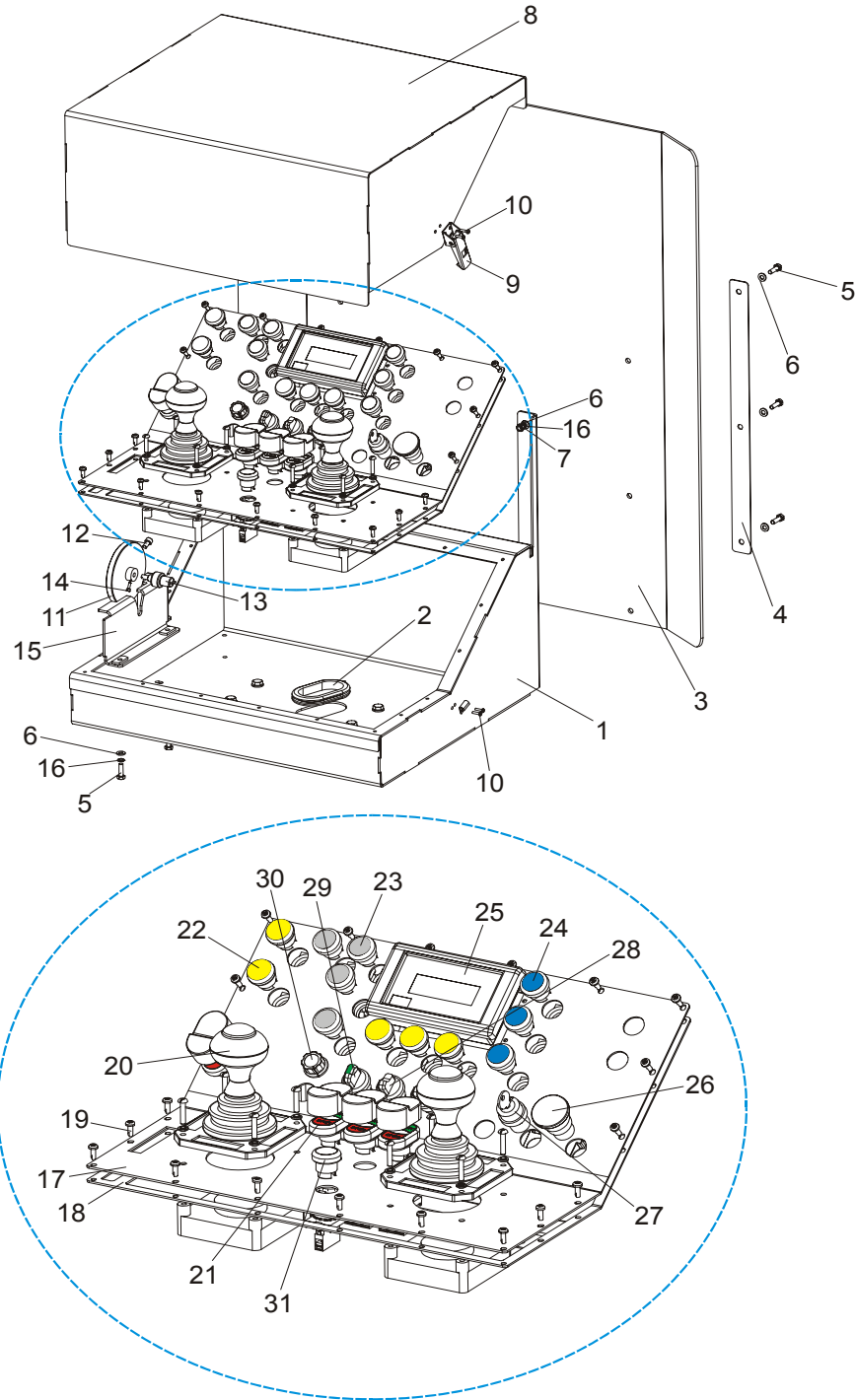

REF	DESCRIPTION (◆ Indicates Parts Available In Assemblies Only)	PART #	QTY.
	CONTROL BOX, LT70 AC REMOTE COMPLETE	090135	
1	Box Weldment, LT70AC Remote Control Painted	090131-1	1
2	Grommet, Rubber	087065	1
3	Guard, LT70 Control Box PC	090219	1
4	Bar, LT70 AC Remote Operator Guard Mounting Painted	090439-1	2
5	Bolt, M6x20-8.8 Hex Head Full Thread Zinc	F81001-2	9
6	Washer, 6.4 Flat Zinc	F81053-1	15
7	Nut, M6-8-B Hex Nylon Zinc Lock	F81031-2	6
8	Cover Weldment, LT80 AC Remote Control Box Painted	090200-1	1
9	Latch, LT70 Remote Control Box Cover	093121	2
10	Bolt, M3x12 -8.8 Hex Head Full Thread Zinc	F81000-12	8
	Potentiometer Assembly, LT70 Remote Feed Rate Control	092759	1
11	Knob, LT70AC Remote Feed Rate Control	091468	1
12	Screw, M6x10 -8.8 Hex Socket Head Cap Zinc	F81001-12	2
13	Potentiometer, 357-5K	091818	1
14	Screw, M3x10 8.8 PN-EN ISO4762 Hex Socket Head Cap Zinc	F81011-35	1
15	Bracket, Feed Rate Knob Complete Mount	092758-1	1
16	Washer, Z 6.1 Split Lock Zinc	F81053-3	9
	Panel Assembly, LT80AC Remote Control Box Front	090129	1
17	Panel, Remote Control Box Front Painted	091371-1	1
18	Gasket, LT80 AC Remote Control Box	090133	1
19	Screw, #10-24 x 1/2 Phillips Head	F05015-17	20
20	Joystick, HLU 110-1 T Control	090123	2
21	Button, 24V Illuminated START/STOP W/Boot	090452	4
22	Light, M22 24V LED Yellow Control	090450	5
23	Pushbutton, M22 Momentary Illuminated White	093192	4
24	Pushbutton, M22 Momentary Blue Flat	093118	3
25	Display, DIRECT OP-440	088142	1
26	Button, XB2BS542+ZB2-BE102 Emergency Stop	086815	1
	Contact, ZBE102	086810	1
27	Switch, XB4 BG33 Key	087350	1
	Contact, ZBE101	087817	1
28	Switch, 2-Position Illuminated Maintained Selector	091467	2
29	Switch, M22 3-Position Illuminated Selector	091359	1
30	Knob, 1/4"ID Fluted Round Plastic	033478	1
	Potentiometer, 500K 2W CP	024553	1
31	Pushbutton, M22 Momentary White Flat	093120	1

5.2 Control Box Pedestal Assembly

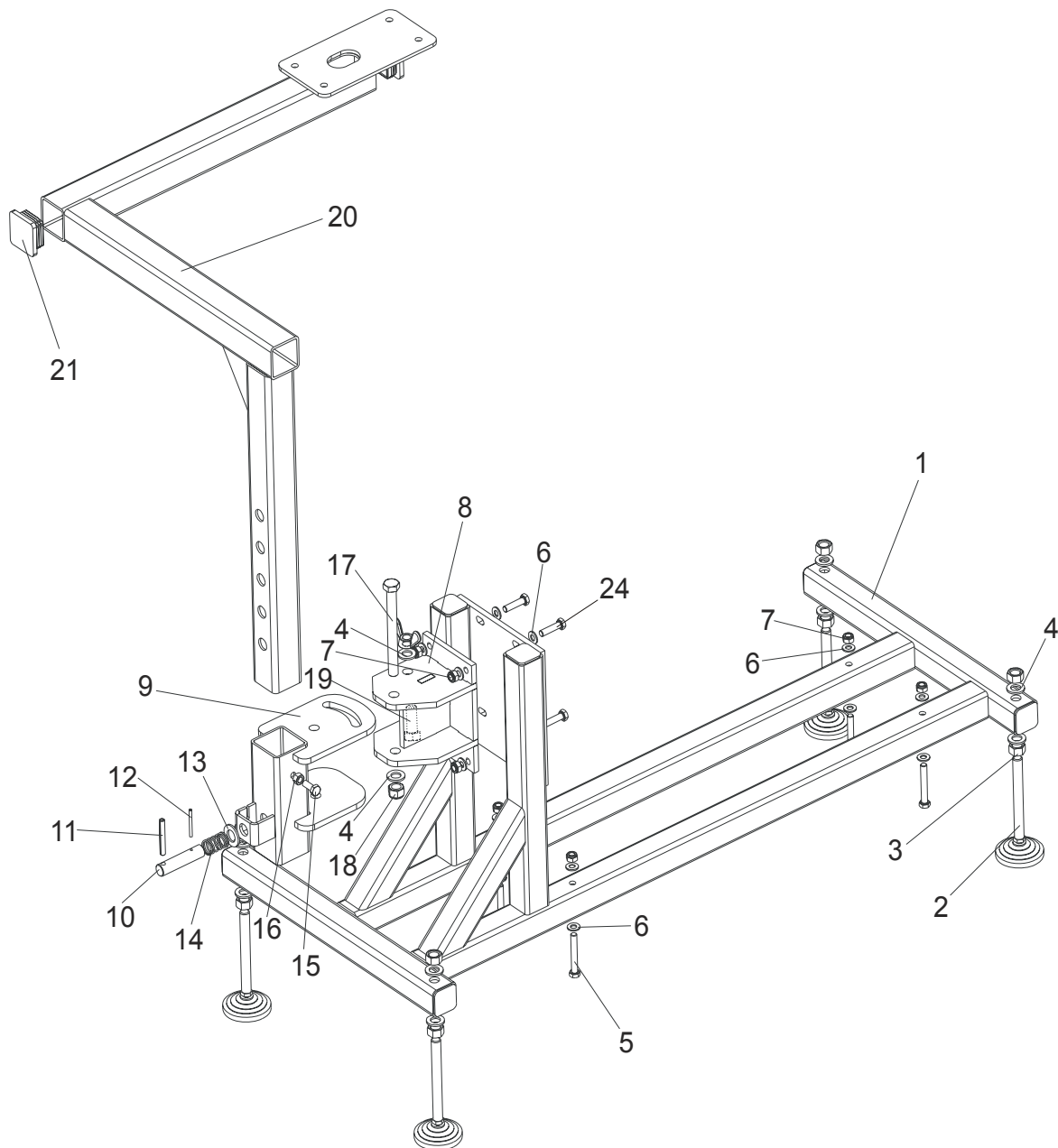

REF	DESCRIPTION (◆ Indicates Parts Available In Assemblies Only)	PART #	QTY.
	CONTROL BOX PEDESTAL ASSEMBLY	093989	1
1	Mount Weldment, LT70 Remote Electric Box	093306-1	1
2	Foot, LV.A-80-14 M16X108 Levelling	093434	4
3	Nut, M16-5.8 Hex Zinc	F81036-1	8
4	Washer, 17 Flat Zinc	F81058-1	10

5	Bolt, M10x70-8.8 Hex Head Full Thread Zinc	F81003-20	4	
6	Washer, 10.5 Flat Zinc	F81055-1	12	
7	Nut, M10-8-B Hex Nylon Zinc Lock	F81033-1	12	
	Pivot Assembly, Control Box Pedestal	091411	1	
8	Bracket, Pivot Weldment Mount Zinc-Plated	091419-1	1	
9	Pivot Weldment, Control Box Pedestal Zinc-Plated	091488-1	1	
10	Pin, Zinc-Plated	087012-1	1	
11	Pin, 8x65 Roll Zinc	F81046-1	1	
12	Pin, 4x50 Roll Zinc	F81044-6	1	
13	Washer, 21 Flat Zinc	F81059-2	1	
14	Spring, 21 Dia.x38x2 Zinc-Plated	087040	1	
15	Bolt, M10x25-8.8 Hex Head Full Thread Zinc	F81003-11	1	
16	Nut, M10-8-B Hex Zinc	F81033-3	1	
17	Bolt, M16x160 -8.8 Hex Head Zinc	F81006-20	1	
18	Nut, M16-8 Hex Nylon Zinc Lock	F81036-2	1	
19	Bolt, M16x40-8.8 Hex Head Full Thread Zinc	F81006-13	1	
20	Pedestal, LT70 Remote Control Box	093305-1	1	
21	Cap, sr 1540 #199211 Tube End	089710	2	

5.3 Main Electric Box

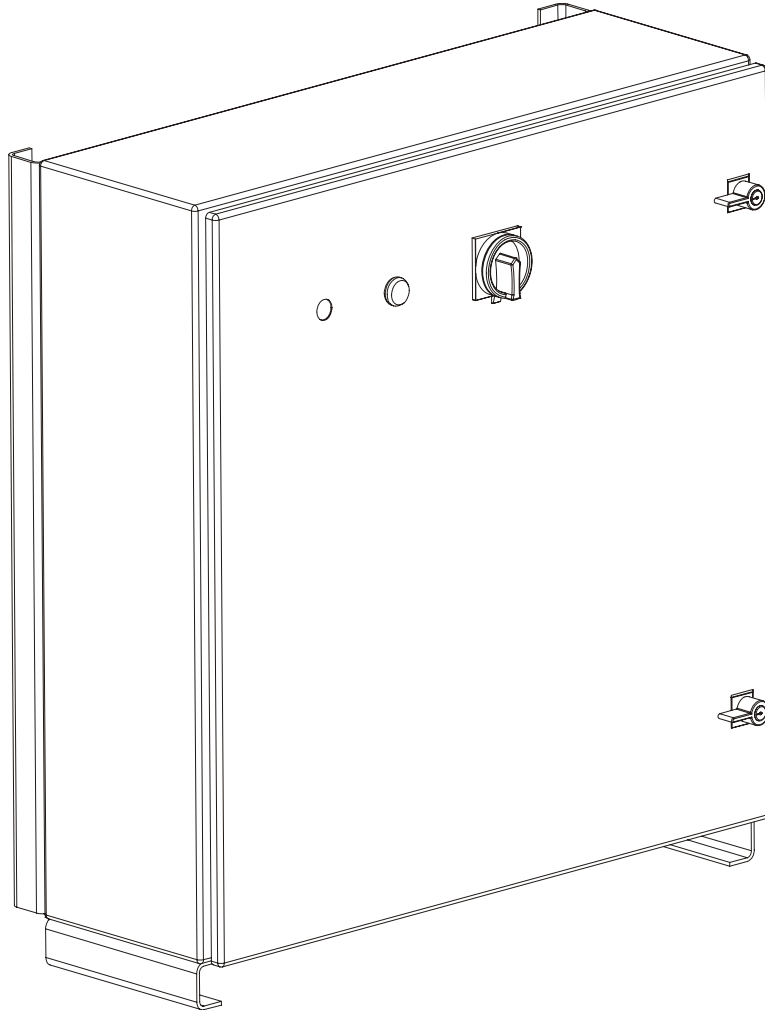

REF	DESCRIPTION (◆ Indicates Parts Available In Assemblies Only)	PART #	QTY.	
	MAIN ELECTRIC BOX, REMOTE SAWMILLS Patrz Rozdział 10.1 LT70 AC Remote Operator's Manual	091097	1	

SECTION 6 UP/DOWN SYSTEM

6.1 Up/Down Rollers & Covers

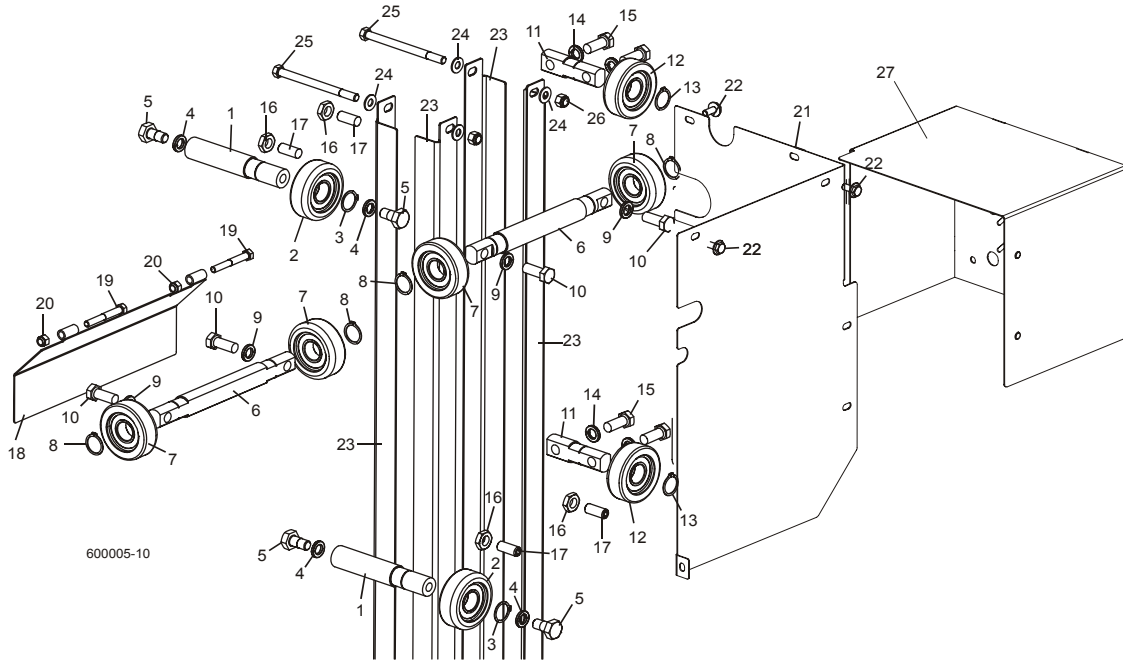

REF	DESCRIPTION (◆ Indicates Parts Available In Assemblies Only)	PART #	QTY.
	ROLLER ASSEMBLY, INSIDE UP/DOWN	089456	2
1	Shaft, Inside Up/Down Roller	088817	1
2	Bearing, CBK-468 Rolling	088433	1
3	Ring, Z30 Outside Retaining	F81090-23	1
4	Washer, 13 Flat Zinc	F81056-1	2
5	Bolt, M12x25-8.8 Hex Head Full Thread Zinc	F81004-31	2
	ROLLER ASSEMBLY, OUTSIDE UP/DOWN	089454	2
6	Shaft, Long Up/Down Roller	088815	1
7	Bearing, CBK-468 Rolling	088433	2
8	Ring, Z30 Outside Retaining	F81090-23	2
9	Washer, 10.5 Flat Zinc	F81055-1	3
10	Bolt, M10x35-8.8 Hex Head Full Thread Zinc	F81003-17	3
	ROLLER ASSEMBLY, SHORT UP/DOWN	089455	2
11	Shaft, Short Up/Down Roller	088816	1
12	Bearing, CBK-468 Rolling	088433	1
13	Ring, Z30 Outside Retaining	F81090-23	1
14	Washer, 10.5 Flat Zinc	F81055-1	2
15	Bolt, M10x35-8.8 Hex Head Full Thread Zinc	F81003-17	2
16	NUT, M10-04-W HEX THIN ZINC	F81033-6	4

6**UP/Down System***Up/Down Rollers & Covers*

17	SCREW, GN 913.3-M10-40-MS SET	F81003-65	4	
18	GUARD WELDMENT, UP/DOWN ROLLER	089483-1	1	
19	BOLT, M8X16-8.8-B HEX HEAD FULL THREAD ZINC	F81002-20	4	
20	WASHER, 8.4 FLAT ZINC	F81054-1	9	
21	GUARD WELDMENT, RA-08 UP/DOWN GEAR BOX SIDE PTD	091319-1	1	
22	BOLT, M8X12-8.8 HEX HEAD FULL THREAD ZINC	F81002-6	5	
23	ANGLE, MAST TUBE	088492	4	
24	WASHER, 10.5 FLAT ZINC	F81055-1	12	
25	BOLT, M10X125-8.8 HEX HEAD ZINC	F81003-18	4	
26	NUT, M10-8-B HEX NYLON ZINC LOCK	F81033-1	4	
27	GUARD, UP/DOWN MOTOR PAINTED	090501-1	1	

6.2 Up/Down Chain & Sprockets

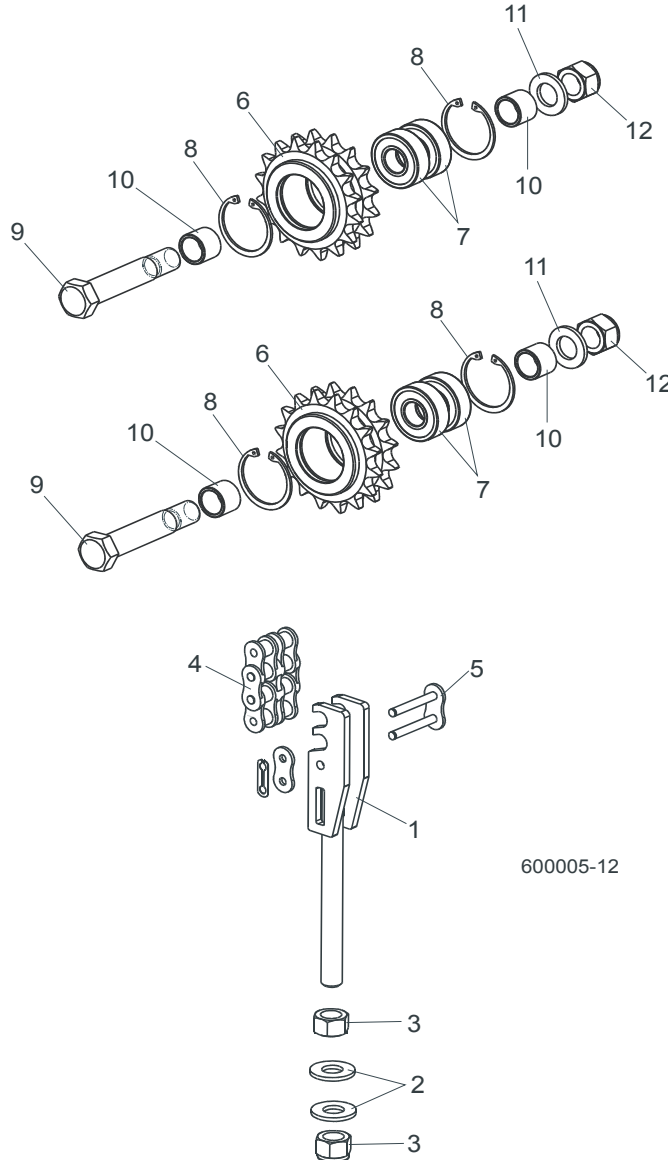

REF	DESCRIPTION (◆ Indicates Parts Available In Assemblies Only)	PART #	QTY.
1	TENSIONER WELDMENT, UP/DOWN CHAIN ZINC-PLATED	088551-1	1
2	WASHER, 13 FLAT ZINC	F81056-1	2
3	NUT, M12-8 HEX NYLON ZINC LOCK	F81034-2	2
4	CHAIN, 10B-2 113-LINK UP/DOWN	088672	1
5	LINK, 10B-2Pz MASTER	088673	1
	SPROCKET ASSEMBLY, UP/DOWN IDLER	088470	1
6	Sprocket, Idler Zinc-Plated	088471-1	1
7	Bearing, 6203-2RS FLT Rolling	086114	2

6 UP/Down System

Up/Down Chain & Sprockets

8	Ring, W40 Inside Retaining	F81090-3	2	
9	Bolt, M16D1F6 x 90-8.8 Hex Fit W/Short Thread Zinc	F81006-15	1	
10	Bushing, Up/Down Sprocket Spacer Zinc-Plated	088792-1	2	
11	Washer, 17 Flat Zinc	F81058-1	1	
12	Nut, M16-8 Hex Nylon Zinc Lock	F81036-2	1	

6.3 Up/Down Drive Assembly

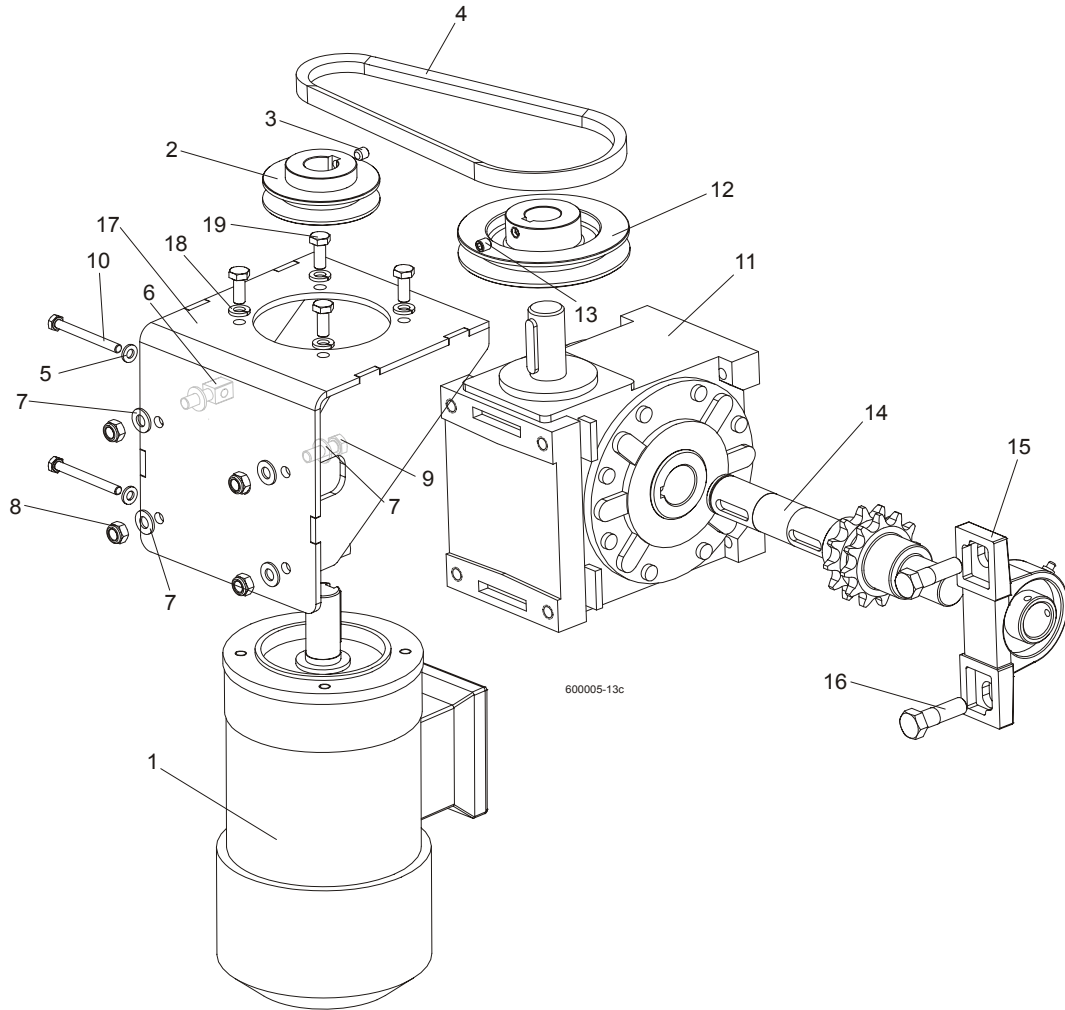

REF	DESCRIPTION (◆ Indicates Parts Available In Assemblies Only)	PART #	QTY.	
	MOTOR W/MOUNT BRACKET, AC UP/DOWN	090493	1	
1	Motor, STKg 90 4S2 IMB14/162 AC	086530	1	
2	Pulley, AC Motor Painted	090497-1	1	
3	Screw, M8x8-33H Hex Socket Set Flat Point Zinc	F81014-1	1	
4	V-Belt, HA-670 (STOMIL SANOK)	091328	1	
5	Washer, 6.4 Flat Zinc	F81053-1	2	
6	Bolt, Special - Zinc Plated	088962-1	2	
7	Washer, 8.4 Flat Zinc	F81054-1	8	
8	Nut, M8-8-B Hex Nylon Zinc Lock	F81032-2	4	
9	Bolt, M8x25-8.8-B Hex Head Full Thread Zinc	F81002-5	2	
10	Bolt, M6x60-8.8 Hex Head Full Thread Zinc	F81001-9	2	
	GEAR BOX ASSEMBLY, UP/DOWN	091310	1	

6

UP/Down System*Up/Down Drive Assembly*

11	Gear Box, RA-08/64/WBS/D1/S,N/V5	091306	1	
12	Pulley, RA-08/64 Gear Box Painted	091308-1	1	
13	Screw, M8x8-33H Hex Socket Set Flat Point Zinc	F81014-1	1	
14	Shaft, Up/Down Output W/Sprocket	091311	1	
15	Bearing Assembly, UCP205 CX	088468	1	
16	Bolt, M12x40-8.8 Hex Head Zinc	F81004-1	1	
17	BRACKET, AC UP/DOWN MOTOR MOUNT PAINTED	090494-1	1	
18	WASHER, 8.2 SPLIT LOCK ZINC	F81054-4	4	
19	BOLT, M8X20-8.8-B HEX HEAD FULL THREAD ZINC	F81002-4	4	

6.4 Sensor Assembly

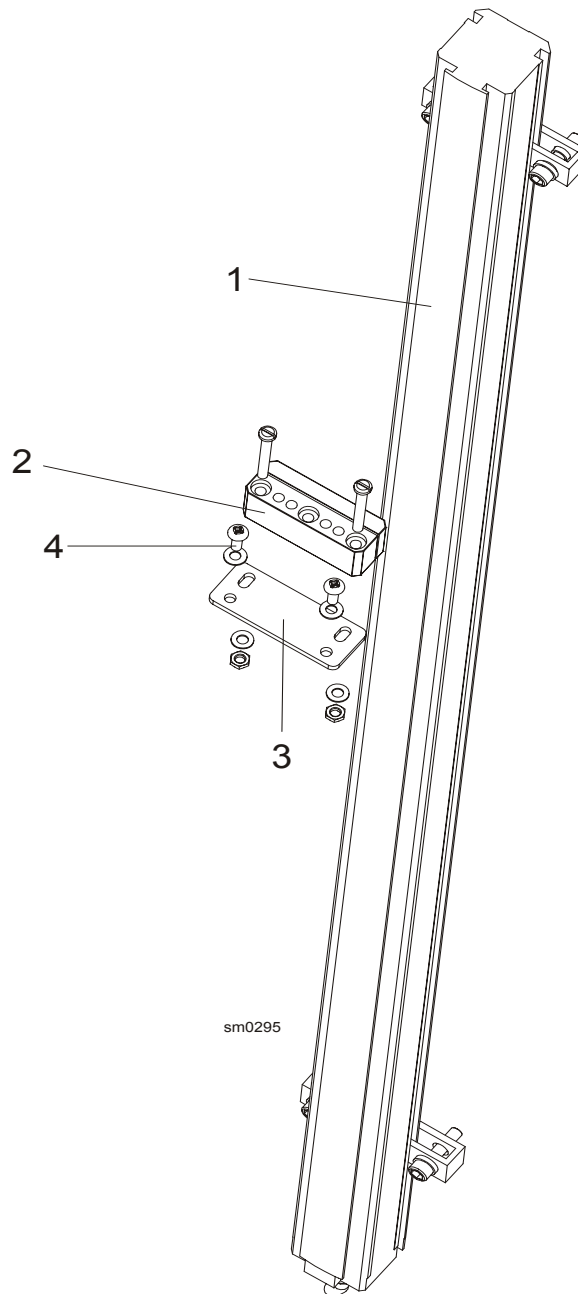

REF	DESCRIPTION (◆ Indicates Parts Available In Assemblies Only)	PART #	QTY.
1	SENSOR, BTL5-E10-M0900-P-KA05 ANALOG LINEAR	088297	1
2	MAGNET, BTL5-P-5500-2 SENSOR	088298	1
	PLATE, BALLUFF SENSOR MAGNET MOUNT W/MOUNTING HARDWARE	092521	1
3	Plate, Balluff Sensor Magnet mount painted	092519-1	1

6 UP/Down System

Sensor Assembly

4	Screw, M4x12 -5.8-B Cross recessed pan head zinc	F81011-43	2	
---	--	-----------	---	--

SECTION 7 FEED SYSTEM & TRACK ROLLERS

7.1 Upper Track Rollers & Wipers

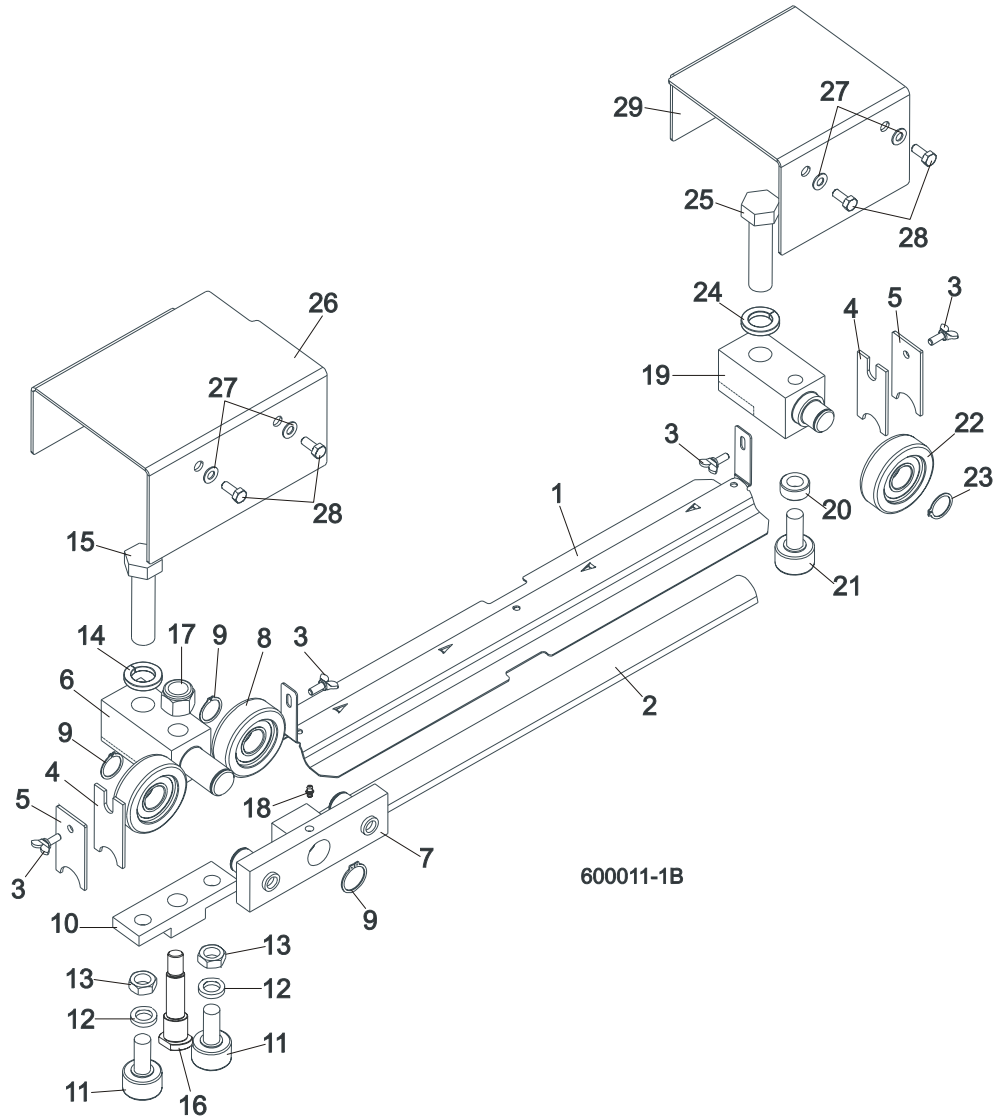

600011-1B

REF	DESCRIPTION (◆ Indicates Parts Available In Assemblies Only)	PART #	QTY.
1	COVER, MIDDLE TRACK	092868-1	1
2	STRIP, FELT	S09915	1
3	SCREW, M6X16 DIN 316 THUMB	F81001-16	4
4	WIPER, TOP RAIL	M04113	2
5	PLATE, TRACK WIPER	088559-1	2
	ROLLER ASSEMBLY, FRONT UPPER TRACK (TANDEM)	088530	1
6	Block, Front Roller Mount	088532	1

7 FEED SYSTEM & TRACK ROLLERS

Upper Track Rollers & Wipers

7	Block Assembly, Front Roller	088533	1	
8	Bearing, CBK-468 Rolling	088433	2	
9	Ring, Z30 Outside Retaining	F81090-23	2	
10	Block, Cam Follower Mount	088520	1	
11	Bearing, Cam Follower (McGill)	012797	2	
12	Washer, 16.3 Split Lock Zinc	F81058-2	2	
13	Nut, 5/8"-18 Zinc	F05010-11	2	
14	Washer, Z24.5 Split Lock Zinc	F81061-4	1	
15	Bolt, M24 x 2 x 90-8.8 Hex Head Full Thread Zinc	F81009-2	1	
16	Pin, Cam Follower Mount	088531	1	
17	Nut, M16-8 Hex Nylon Zinc Lock	F81036-2	1	
18	Fitting, M6 Straight Grease	086280	1	
	ROLLER ASSEMBLY, REAR UPPER TRACK	088529	1	
19	Block, Rear Roller Mount	088528	1	
20	Spacer, Cam Follower	088536	1	
21	Bearing, Cam Follower (McGill)	012797	1	
22	Bearing, CBK-468 Rolling	088433	1	
23	Ring, Z30 Outside Retaining	F81090-23	1	
24	Washer, Z24.5 Split Lock Zinc	F81061-4	1	
25	Bolt, M24x2x90-8.8 Hex Head Full Thread Zinc	F81009-2	1	
26	COVER, FRONT UPPER TRACK ROLLER	088526	1	
27	WASHER, 6.4 FLAT ZINC	F81053-1	4	
28	BOLT, M6X16 8.8 HEX HEAD FULL THREAD ZINC	F81001-15	4	
29	COVER, REAR UPPER TRACK ROLLER	088527	1	

7.2 Feed Chain/Stop

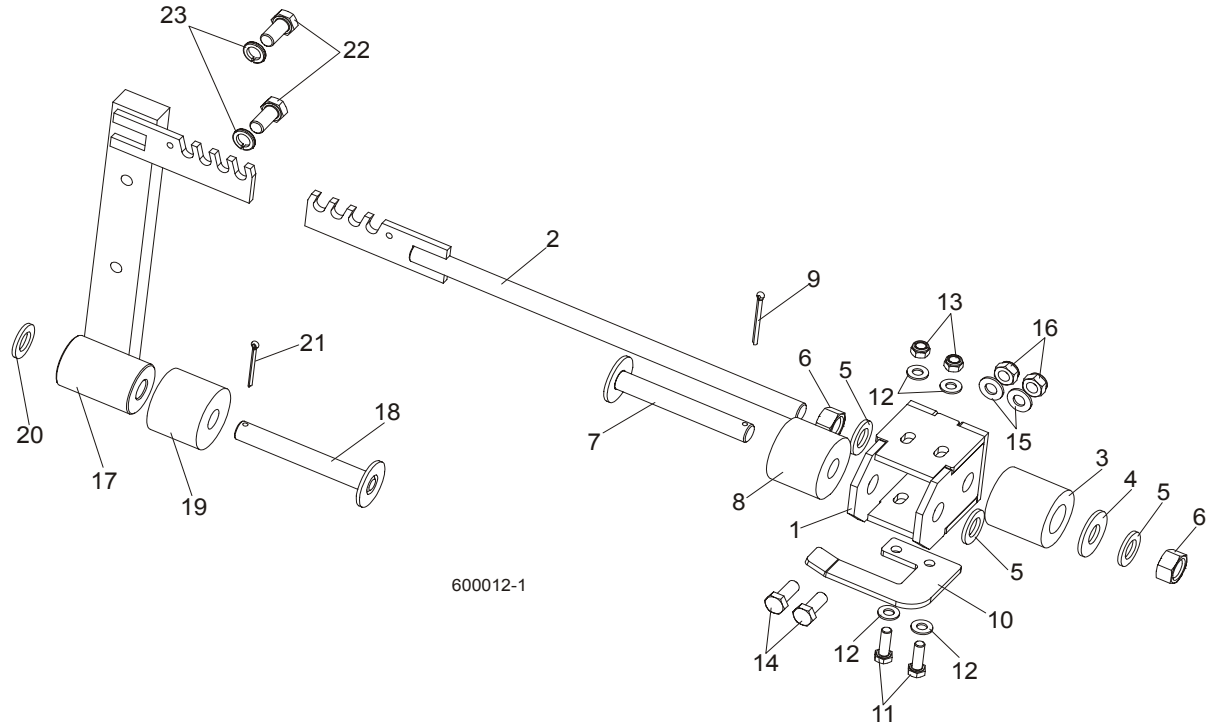

600012-1

REF	DESCRIPTION (◆ Indicates Parts Available In Assemblies Only)	PART #	QTY.
1	MOUNT WELDMENT, FRONT CARRIAGE STOP	089365-1	1
2	TENSIONER WELDMENT, POWER FEED CHAIN	089364-1	1
3	SPRING, LT15 BLADE TENSIONER	014828	1
4	WASHER, SPECIAL ZINC-PLATED	089360-1	1
5	WASHER, 17 FLAT ZINC	F81058-1	3
6	NUT, M16-5.8 HEX ZINC	F81036-1	2
7	PIN, RUBBER CARRIAGE STOP	089361-1	1
8	STOP, RUBBER CARRIAGE	P12165	1
9	PIN, S-Zn 4x25 COTTER	F81043-2	1
10	BRACKET, LIMIT SWITCH	086473-1	1
11	BOLT, M8x25-8.8-B HEX HEAD FULL THREAD ZINC	F81002-5	2
12	WASHER, 8.4 FLAT ZINC	F81054-1	4
13	NUT, M8-8-B HEX NYLON ZINC LOCK	F81032-2	2
14	BOLT, M10x25 8.8 HEX HEAD FULL THREAD	F81003-31	2
15	WASHER, 10.5 FLAT ZINC	F81055-1	2
16	NUT, M10-8-B HEX NYLON ZINC LOCK	F81033-1	2
	STOP ASSEMBLY, REAR POWER FEED	089362	1
17	Stop Weldment, Rear Power Feed	088346-1	1
18	Pin, Rubber Carriage Stop	089361-1	1
19	Stop, Rubber Carriage	P12165	1

7 FEED SYSTEM & TRACK ROLLERS

Feed Chain/Stop

20	Washer, 17 Flat Zinc	F81058-1	1	
21	Pin, S-Zn 4x25 Cotter	F81043-2	1	
22	BOLT, M12x25-8.8 HEX HEAD FULL THREAD ZINC	F81004-31	2	
23	WASHER, 13 FLAT ZINC	F81056-1	2	
	CHAIN, 10B-1 10RM POWER FEED	088670	1	
	LINK, 10B-1PZ MASTER	088671	2	

7.3 Power Feed Assembly

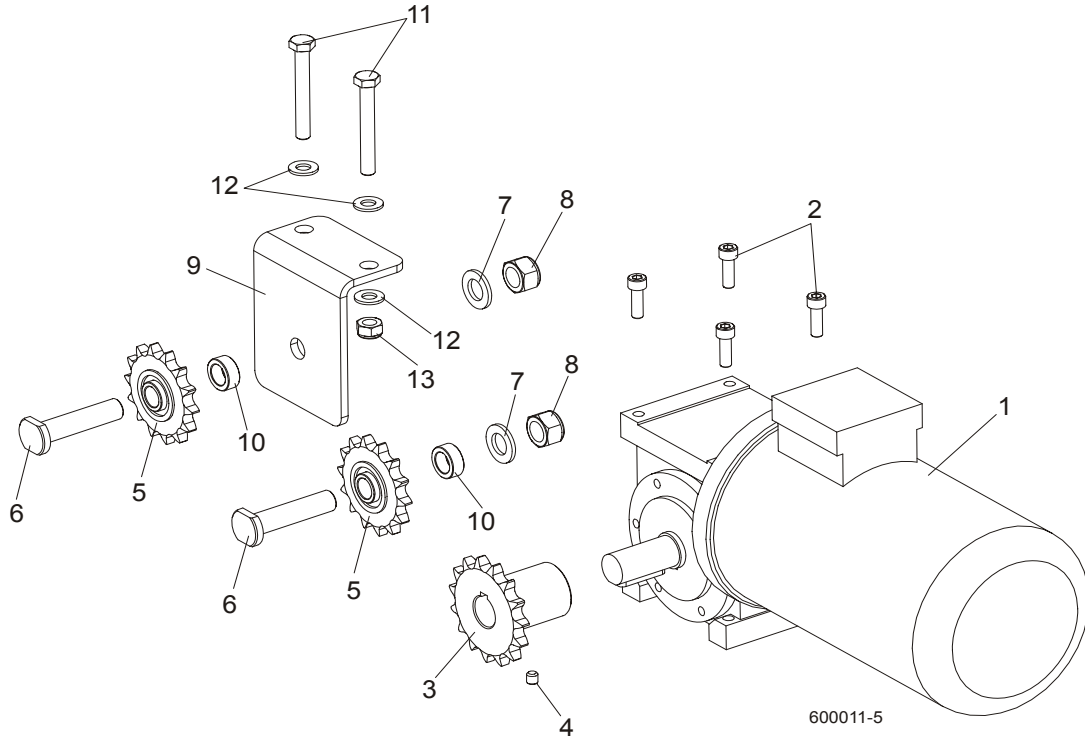

REF	DESCRIPTION (◆ Indicates Parts Available In Assemblies Only)	PART #	QTY.
1	GEAR BOX, RA-0.5/7.5/D3/S/B8 I.3 koIn.160/19 B14/1	088565	1
2	SCREW, M8x25 -8.8 HEX SOCKET HEAD CAP ZINC	F81002-21	4
3	SPROCKET, 10B Z15 ZINC-PLATED	088541-1	1
4	SCREW, M8x8-33H HEX SOCKET SET FLAT POINT ZINC	F81014-1	2
5	SPROCKET, KSR 16.L0.10.10.14.08 W/BEARING	088867	2
6	PIN, SPROCKET MOUNT ZINC-PLATED	088994-1	2
7	WASHER, 17 FLAT ZINC	F81058-1	2
8	NUT, M16-8 HEX NYLON ZINC LOCK	F81036-2	2
9	BRACKET, POWER FEED SPROCKET MOUNT	088507-1	1
10	SPACER, POWER FEED SPROCKET	088550-1	1
11	BOLT, M10x75-8.8 HEX HEAD ZINC	F81003-15	2
12	WASHER, 10.5 FLAT ZINC	F81055-1	4
13	NUT, M10-8-B HEX NYLON ZINC LOCK	F81033-1	2

7 FEED SYSTEM & TRACK ROLLERS

Lower Track Rollers

7.4 Lower Track Rollers

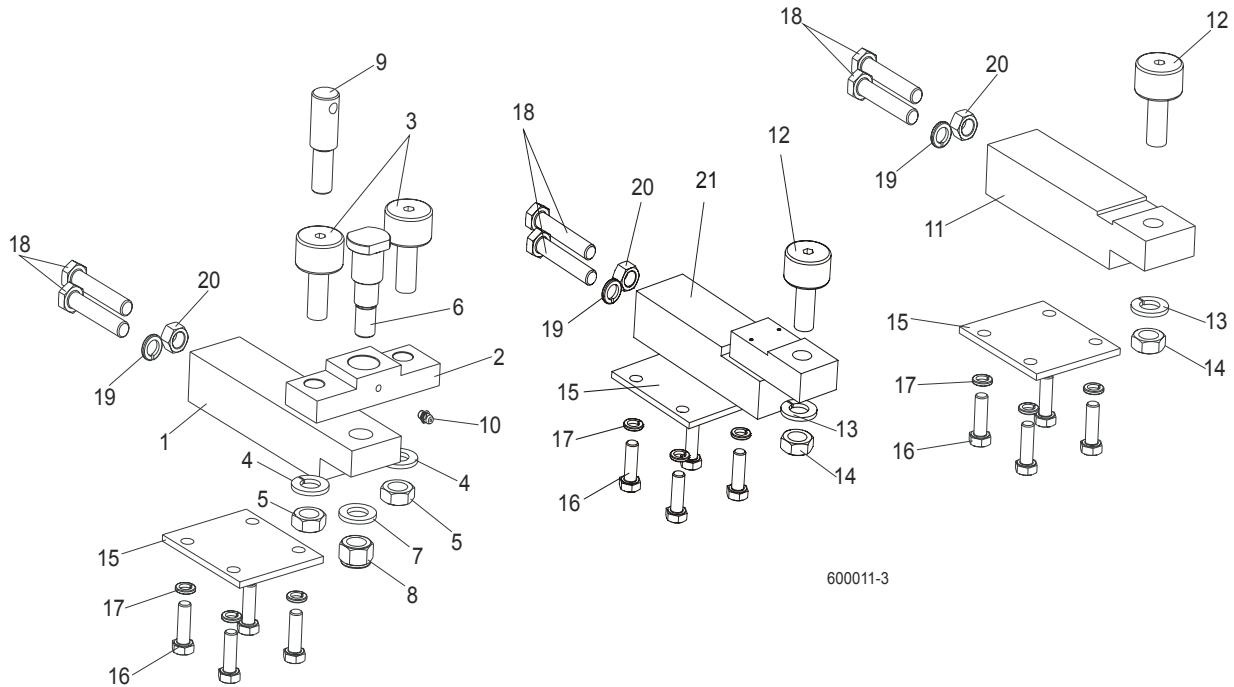

REF	DESCRIPTION (◆ Indicates Parts Available In Assemblies Only)	PART #	QTY.
	BLOCK ASSEMBLY, MAST VERTICAL ALIGNMENT DOUBLE	088523	1
1	Block, Mast Vertical Alignment Double	088517	1
2	Block, Cam Follower Mount	088520	1
3	Bearing, Cam Follower (McGill)	012797	2
4	Washer, 16.3 Split Lock Zinc	F81058-2	2
5	Nut, 5/8"-18 Zinc-Plated	F05010-11	2
6	Pin, Cam Follower Mount	088521	1
7	Washer, 17 Flat Zinc	F81058-1	1
8	Nut, M16-8 Hex Nylon Zinc Lock	F81036-2	1
9	Pin, Safety Lock	088519	1
10	Fitting, M6 Straight Grease	086280	1
	BLOCK ASSEMBLY, MAST VERTICAL ALIGNMENT SINGLE	088524	1
11	Block, Mast Vertical Alignment Single	088518	1
12	Bearing, Cam Follower (McGill)	012797	1
13	Washer, 16.3 Split Lock Zinc	F81058-2	1
14	Nut, 5/8"-18 Zinc-Plated	F05010-11	1
15	PLATE, LOWER TRACK ROLLER RETAINER	088516	2
16	BOLT, M10X30-5.8 HEX HEAD FULL THREAD ZINC	F81003-2	8
17	WASHER, 10.2 SPLIT LOCK ZINC	F81055-2	8
18	BOLT, M12X1.25X65-8.8 HEX HEAD FULL THREAD ZINC	F81004-40	4
19	WASHER, Z12.2 SPLIT LOCK ZINC	F81056-2	2

FEED SYSTEM & TRACK ROLLERS

Lower Track Rollers

7

20	NUT, M12X1.25-8 HEX ZINC	F81034-8	2	
21	BLOCK WELDMENT, LOWER TRACK ROLLER MOUNT	091425	1	

8 BED FRAME ASSEMBLY

Bed Rails

SECTION 8 BED FRAME ASSEMBLY

8.1 Bed Rails

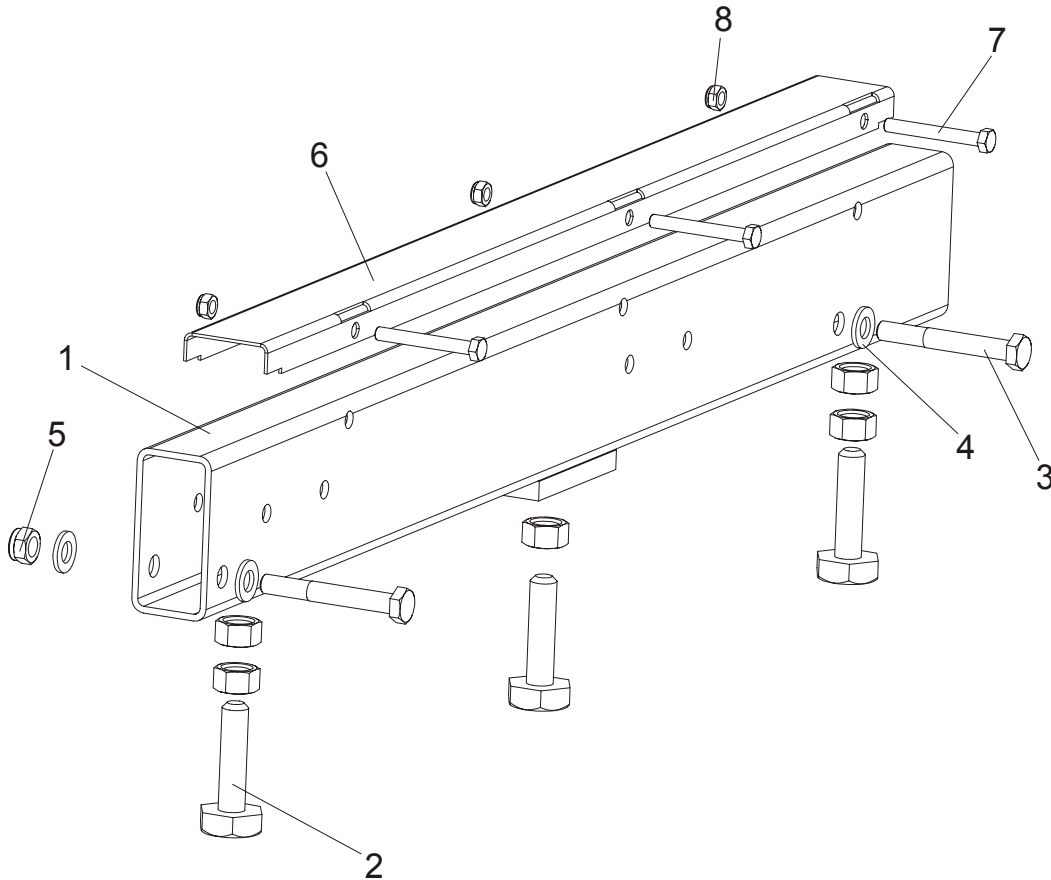

REF	DESCRIPTION (◆ Indicates Parts Available In Assemblies Only)	PART #	QTY.
1	TUBE, BED RAIL	096994	1
2	ADJUSTMENT BOLT (M16) & TWO NUTS	093710	3
3	BOLT, M12x90-8.8 HEX HEAD ZINC	F81004-2	2
4	WASHER, 13 FLAT ZINC	F81056-1	4
5	NUT, M12-8 HEX NYLON ZINC LOCK	F81034-2	2
6	COVER, STAINLESS STEEL BED RAIL	S09944	1
7	BOLT, M8x65-5.8 HEX HEAD ZINC	F81002-3	3
8	NUT, M8-8-B HEX NYLON ZINC LOCK	F81032-2	3

8.2 Wireway Assembly

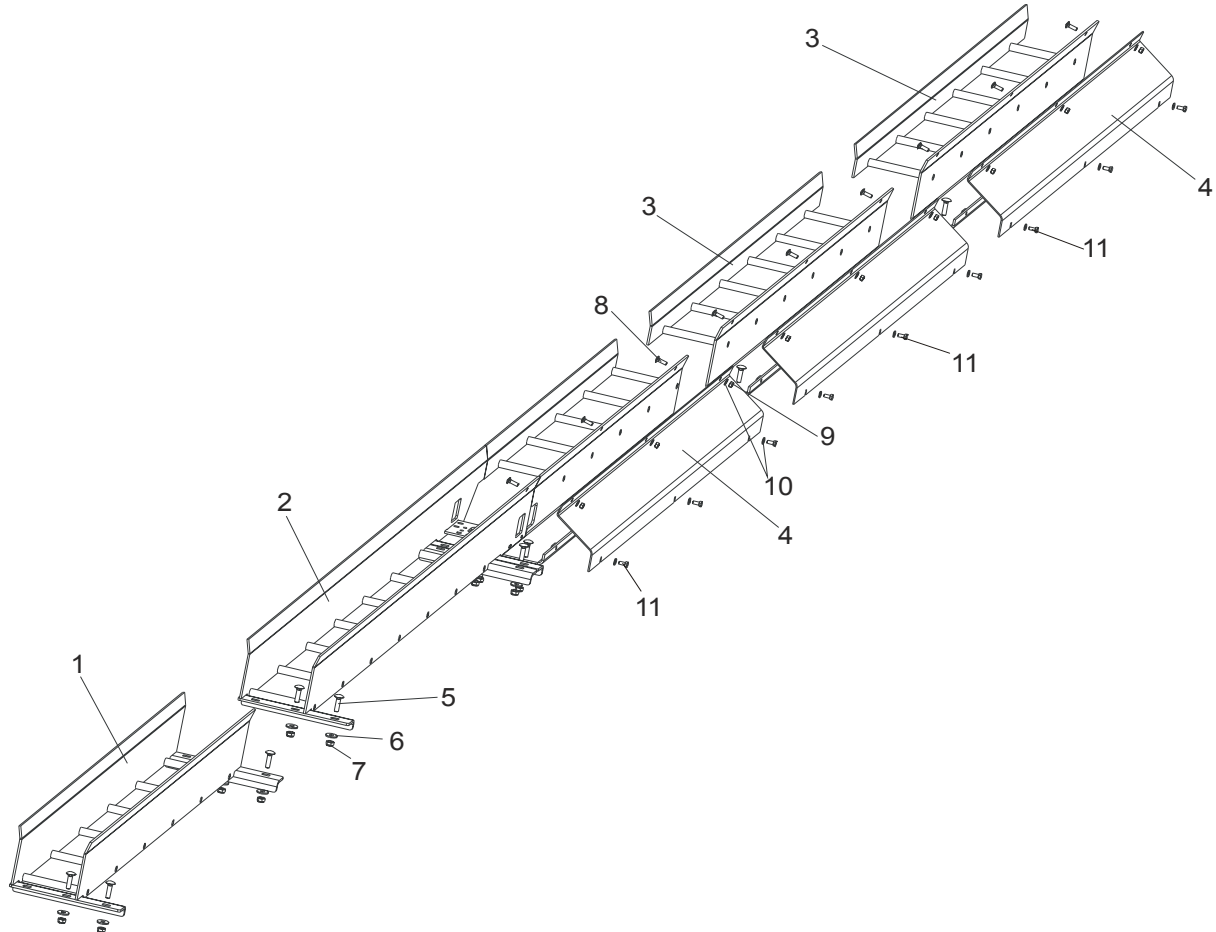

REF	DESCRIPTION (◆ Indicates Parts Available In Assemblies Only)	PART #	QTY.
	WIREWAY ASSEMBLY, LT70	093570	
1	Wireway Weldment, LT70 Painted (1)	093555-1	1
2	Wireway Weldment, LT70 Painted (3)	093569-1	1
3	Wireway Weldment, LT70 Painted (2)	093568-1	2
4	Cover, LT70/300 Wireway (1)	093550	3
5	Bolt, Z M10x40 -8.8 Carriage Head Zinc	F81003-40	15
6	Washer, 10.5 Special Flat Zinc	F81055-6	15
7	Nut, M10-8-B Hex Nylon Zinc Lock	F81033-1	15
8	Bolt, M8x20-8.8 Carriage Head Zinc	F81002-11	9
9	Nut, M8-8-B Hex Zinc	F81032-1	9
10	Washer, 8.4 Flat Zinc	F81054-1	18
11	Bolt, M8x16 -8.8-B Hex Head Full Thread Zinc	F81002-20	9

8 BED FRAME ASSEMBLY

Cable Carrier

8.3 Cable Carrier

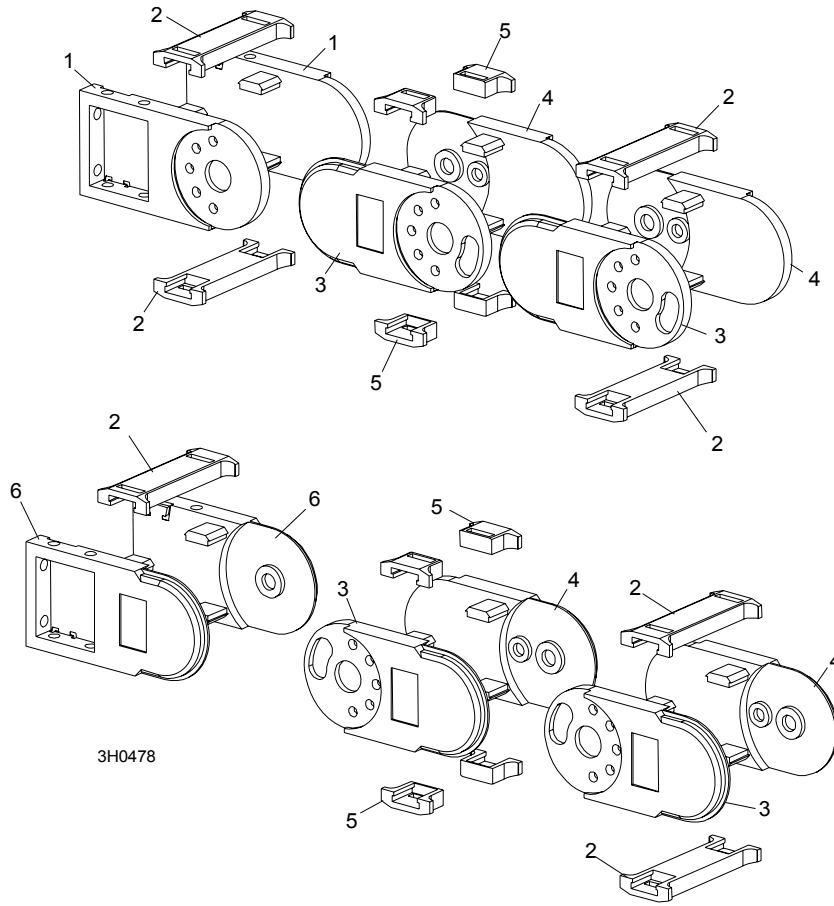

3H0478

REF	DESCRIPTION (◆ Indicates Parts Available In Assemblies Only)	PART #	QTY.
	CABLE CARRIER, LT70REMOTE/LT300	094389	1
1	Link, Nylon Chain Top Mount	023612-3	2
2	Brace, Nylon Chain Long Cross	023612-4	68
3	Link, Nylon Chain Right Side #4040AA	036219	66
4	Link, Nylon Chain Left Side #4040AA	036220	66
5	Brace, Nylon Chain Short Cross	023612-5	136
6	Link, Nylon Chain Bottom Mount	023612-9	2

8.4 Stationary Legs

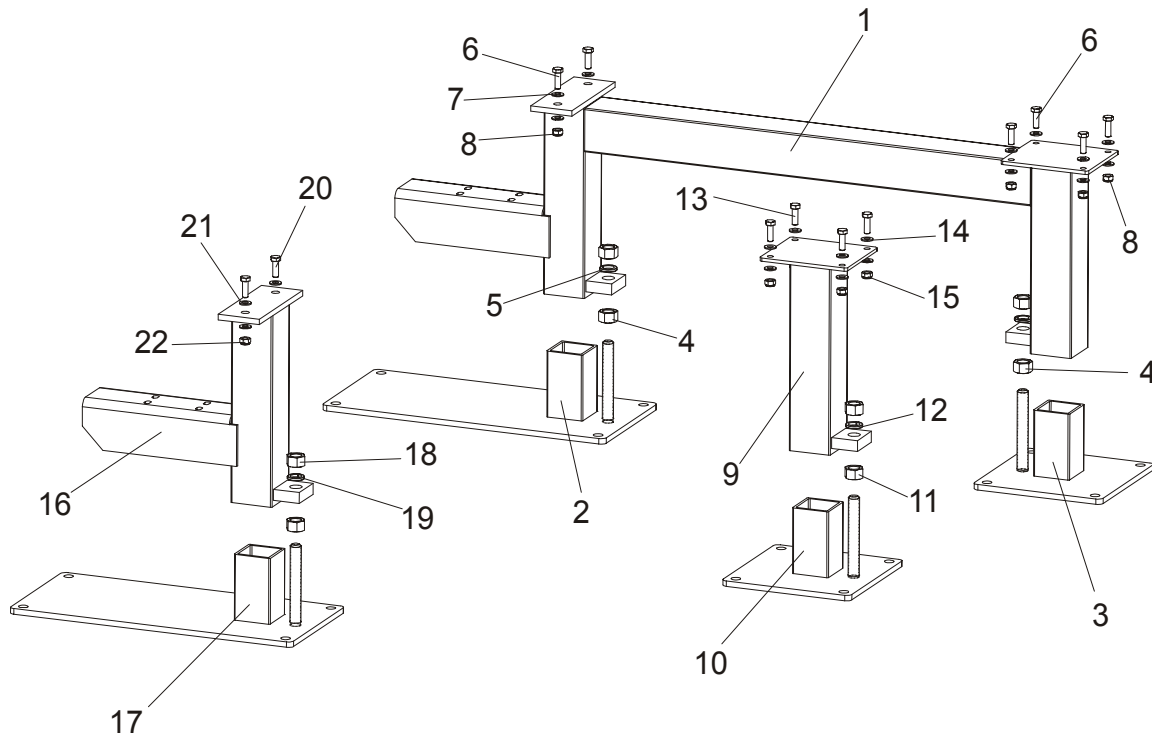

REF	DESCRIPTION (◆ Indicates Parts Available In Assemblies Only)	PART #	QTY.
	STATIONARY LEG KIT, LT70 REMOTE	092975	
	Leg Assembly, LT70 Stationary (3)	089288	4
1	Leg Weldment, Stationary Painted - Upper Part (2)	089277-1	1
2	Plate Weldment, LT70 Leg Foot (2)	093564-1	1
3	Plate Weldment, Leg Foot	089283-1	1
4	Nut, M20-8 Hex Zinc	F81037-1	4
5	Washer, 20.5 Split Lock Zinc	F81059-1	2
6	Bolt, M10x30-5.8 Hex Head Full Thread Zinc	F81003-2	6
7	Washer, 10.5 Flat Zinc	F81055-1	12
8	Nut, M10-8-B Hex Nylon Zinc Lock	F81033-1	6
	Stationary Leg, LT70	093326	2
9	Leg Weldment, LT70 Stationary -Upper Part (2)	091790-1	1
10	Plate Weldment, Leg Foot (3)	089283-1	1
11	Nut, M20-8 Hex Zinc	F81037-1	2
12	Washer, 20.5 Split Lock Zinc	F81059-1	1
13	Bolt, M10x30-5.8 Hex Head Full Thread Zinc	F81003-2	4
14	Washer, 10.5 Flat Zinc	F81055-1	8
15	Nut, M10-8-B Hex Nylon Zinc Lock	F81033-1	4
	Stationary Leg, LT70 (2)	093325	2

8**BED FRAME ASSEMBLY***Stationary Legs*

16	Leg Weldment, LT70 Stationary - Upper Part (5)	089350-1	1	
17	Plate Weldment, LT70 Leg Foot (2)	093564-1	1	
18	Nut, M20-8 Hex Zinc	F81037-1	2	
19	Washer, 20.5 Split Lock Zinc	F81059-1	1	
20	Bolt, M10x30-5.8 Hex Head Full Thread Zinc	F81003-2	2	
21	Washer, 10.5 Flat Zinc	F81055-1	4	
22	Nut, M10-8-B Hex Nylon Zinc Lock	F81033-1	2	

8.5 Board Return Roller Assembly

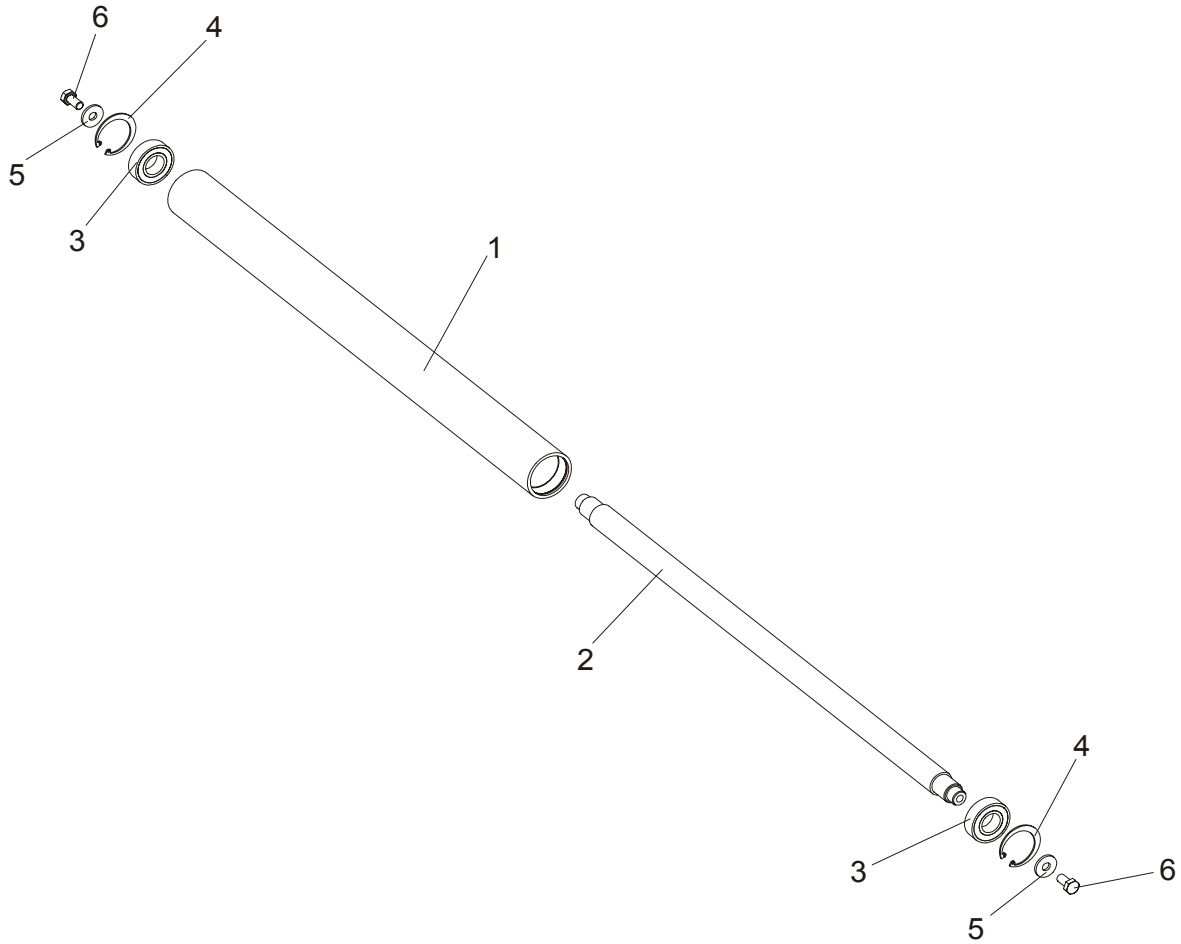

REF	DESCRIPTION (◆ Indicates Parts Available In Assemblies Only)	PART#	QTY.	
	ROLLER ASSEMBLY, LT70 REMOTE PAINTED	093291	1	
1	Tube, LT70 Roller	091781	1	
2	Shaft, LT70 Roller	091793	1	
3	Bearing, 6205 2RS	091804	2	
4	Ring, W50 Inside Retaining	091805	2	
5	Washer, 10.5 Special Flat Zinc	F81055-6	2	
6	Bolt, M10x20-5.8 Hex Head Full Thread Zinc	F81003-1	2	

SECTION 9 HYDRAULIC SYSTEM

9.1 Hydraulic Hoses, LT70 Remote

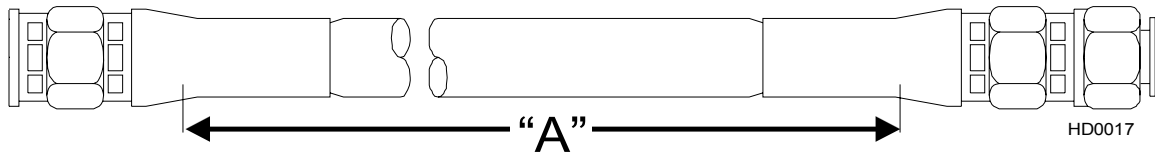

Symbol	Color Code	Qty.	Length "A"	Description	Wood-Mizer Part No.
H1	Black/Brown	2	5m	3/8" Log Infeed Deck	094588
H2	Orange	1	4.4m	3/8" 2-Plane Clamp, In/Out	094589
H3	White	1	4.6m	3/8" 2-Plane Clamp, In/Out	094590
H4	Pink/None	2	4.5m	3/8" Side Supports	094591
H5	Green/Yellow	2	4m	3/8" Turner	094592
H6	None	1	1.1m	3/8" Front Side Support From Tee Fitting, Base	094593
H7	None	1	.95m	3/8" Rear Side Support From Tee Fitting, Base	094594
H8	None	1	.92m	3/8" Front Side Support From Oil Flow Divider, Top	094595
H9	None	1	.72m	3/8" Rear Side Support From Oil Flow Divider, Top	094596
H10	None	1	.65m	3/8" Turner To Oil Flow Divider	094597
H11	None	1	.62m	3/8" Turner To Tee Fitting	094598
H12	None	1	.6m	3/8" Turner To Oil Flow Divider	094599
H13	None	1	.35m	3/8" Hydraulic Pump	094600
H14	Blue/Red	2	6.5m	1/4" 2nd Clamp, Up/Down	094601
H15	White/Orange	2	6.3m	1/4" 2nd Clamp, In/Out	094602
H16	Black/Purple/Green	2	5.6m	1/4" 2nd Toe Board	094603
		1	5.6m	1/4" 2-Plane Clamp, Up/Down	094603
H17	Yellow	1	5.4m	1/4" 2-Plane Clamp, Up/Down	094604
H18	Blue/Red	2	3m	1/4" 1st Clamp, Up/Down	094605
H19	Silver/Brown	2	2.8m	1/4" 1st Toe Board	094606

TABELA 9-0

HYDRAULIC SYSTEM
Hydraulic Hoses, LT70 Remote

9

H20	White/Orange	2	1.7m	1/4" 1st Clamp, In/Out	094607
------------	--------------	---	------	------------------------	--------

TABELA 9-0

9.2 Hydraulic Control Box, LT70 Remote

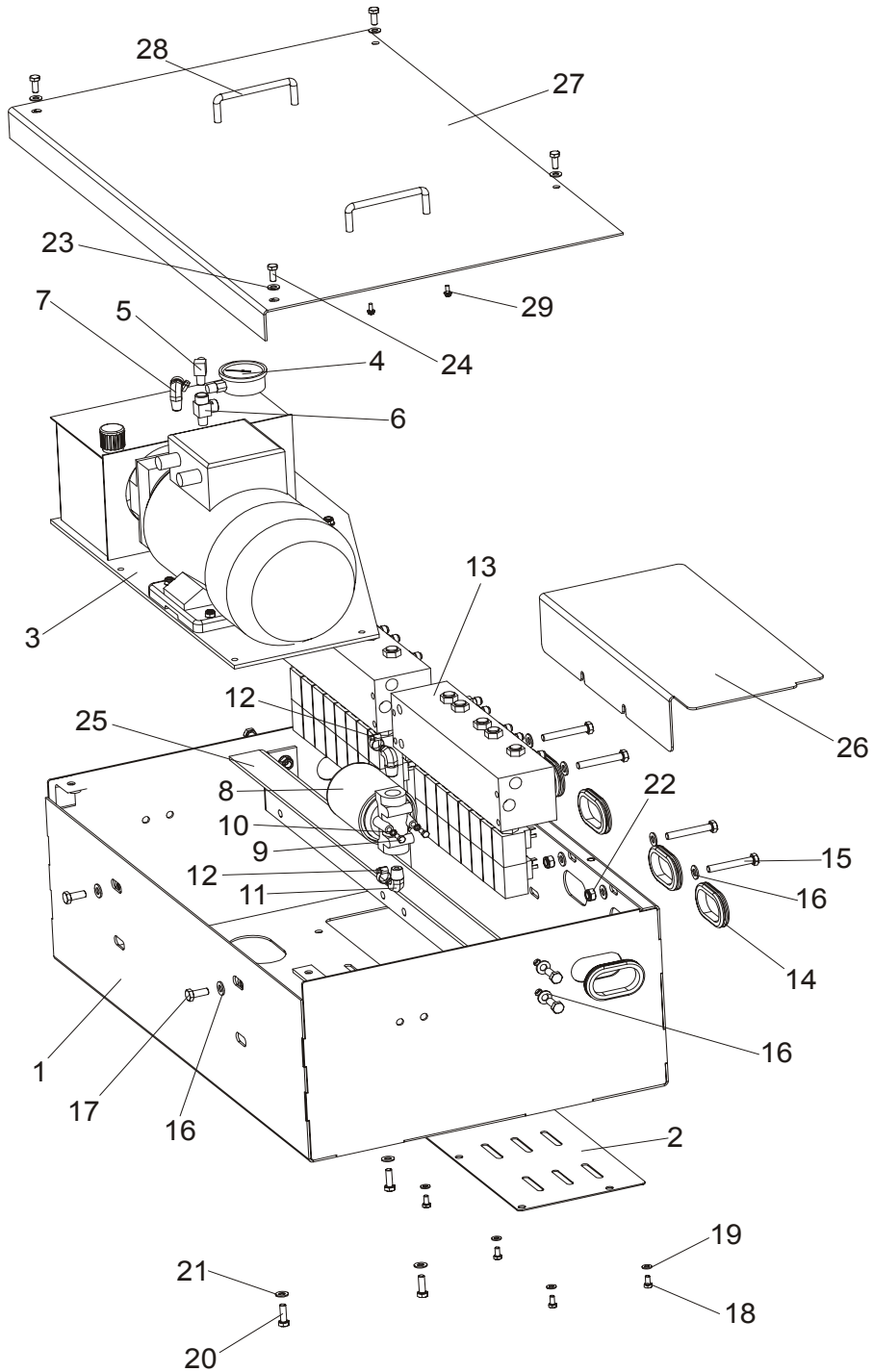

HYDRAULIC SYSTEM

Hydraulic Control Box, LT70 Remote

9

REF	DESCRIPTION (◆ Indicates Parts Available In Assemblies Only)	PART #	QTY.
	BOX, LT70 REMOTE COMPLETE HYDRAULIC CONTROL	094399	1
1	Box Weldment, LT70 AC Remote Hydraulic	094400-1	1
2	Cover, LT70 AC Remote Hydraulic Box Bottom Painted	094406-1	1
3	Hydraulic Pump W/Motor, 4kW 14.5l/min	093459	1
4	Gauge, 3000PSI Hydraulic Fluid Pressure	090552	1
5	Fitting, 3/8JIC-1/4NPT 90L	015491	1
6	Fitting, C3759X4 Male Run Tee	P09141	1
7	Fitting, #6-6(3/8"NPT) - 3/8" Hose Barb Elbow	P12708	1
8	Manifold, 1.2" Hydraulic W/Filter	P22683	1
9	Bolt, 1/4-20x1/2" Hex Head Zinc Grade 2	F05005-15	2
10	Washer, Z 6.1 Split Lock Zinc	F81053-3	2
11	Fitting, 1/2"NPT-3/8" Hose Barb Elbow	P12707	2
12	Clamp, 11/16 Hose Worm	P12739	2
13	Valve Assembly, 8-Spool Hydraulic Patrz Rozdział 9.3	035615	2
	FLUID, .946 L DEXTRON III HYDRAULIC	P12742	8.5 l
	FLUID, 3.78 L EXXON UNIVIS J26 HYDRAULIC	P12824	8.5 l
	FLUID, 3.78 L EXXON UNIVIS P13 HYDRAULIC	P12822	8.5 l
	DECAL, HYDRAULIC FLUID REPLACEMENT	S12825	1
14	Grommet, Rubber	087065	6
15	Bolt, M10x70-8.8 Hex Head Full Thread Zinc	F81003-20	4
16	Washer, 10.5 Flat Zinc	F81055-1	20
17	Bolt, M10x25-8.8 Hex Head Full Thread Zinc	F81003-11	2
18	Bolt, M6x12-8.8 Hex Head Full Thread Zinc	F81001-7	6
19	Washer, 6.4 Flat Zinc	F81053-1	6
20	Bolt, M8x25-8.8-B Hex Head Full Thread Zinc	F81002-5	3
21	Washer, 8.4 Flat Zinc	F81054-1	3
22	Nut, M10-8-B Hex Nylon Zinc Lock	F81033-1	10
23	Washer, 8.4 Flat Zinc	F81054-1	4
24	Bolt, M8x20-8.8-B Hex Head Full Thread Zinc	F81002-4	4
25	Bracket, LT70 Hydraulic Valve Mount	094404	1
26	GUARD, LT70 REMOTE CABLE PAINTED	091518-1	1
27	COVER, HYDRAULIC CONTROL BOX TOP	094405-1	1
28	HANDLE, 4" W/BOLTS	P08065	2
29	BOLT, #8-32x3/8 SELF TAP	F05015-8	4

9.3 Hydraulic Valve

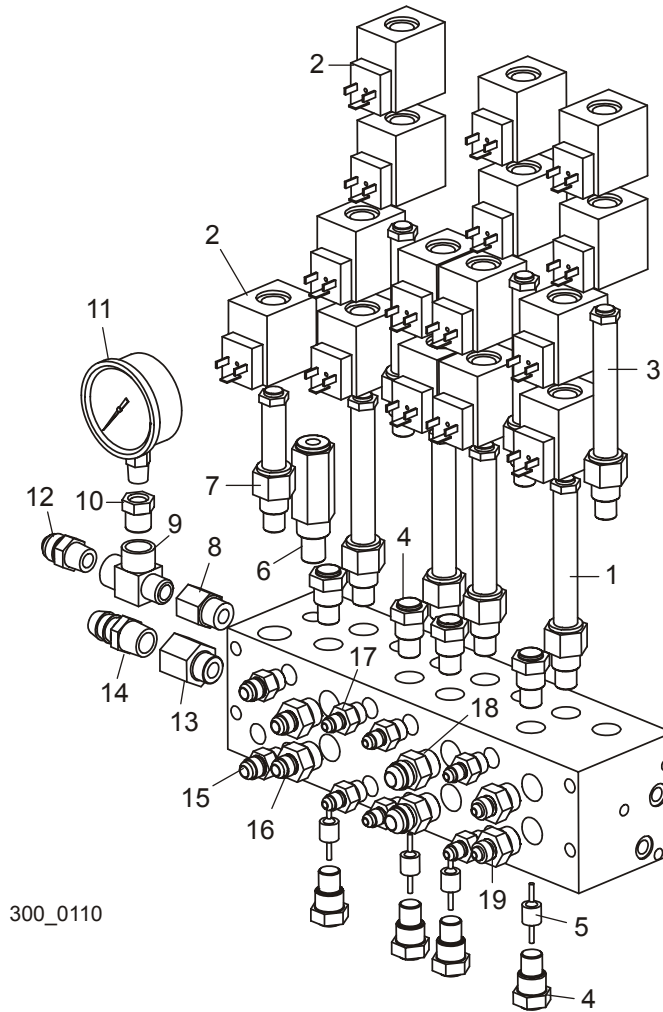

300_0110

REF	DESCRIPTION (◆ Indicates Parts Available In Assemblies Only)	PART #	QTY.
	VALVE ASSEMBLY, LT300 HYDRAULIC	036758	1
	Valve, 7-Spool Expandable Hydraulic	036731	1
1	Valve, Hi-Flow Floating Center Sterling #GS04-53	045820	4
2	Coil, 24V Sterling #CAP-024D	051558	15
3	Valve, 4-Way Sterling #GS04-51	051556	3
4	Valve, Check Sterling #D02B2-2.1N	051559	8
5	Piston, Pilot Sterling #PP02DP	051660	4
6	Valve, Relief Sterling #208-1-B-0-A-C-200	051554	1
7	Valve, 2-Way NO Sterling #GS04-26	051555	1
8	Fitting, #8 SAE x 3/8" NPT Female Adapter	P12706	1
9	Fitting, 3/8" NPT Male Run Tee	016822	1
10	Fitting, 3/8" NPT-1/4 NPT Reducer	015490	1

11	Gauge, 5000 PSI Hydraulic	P10052	1	
12	Fitting, 3/8" NPT x #8 JIC	036822	1	
13	Fitting, #8SAE x 1/2" NPT Female Adapter	035620	1	
14	Fitting, 1/2" NPT x 3/4" Hose Barb	035621	1	
15	Fitting, 3/8" O-Ring x 3/8" JIC	014687	2	
16	Fitting, #8 SAE x #6 JIC	P12703	2	
17	Fitting, 1/4" JIC x 3/8" O-Ring	P26284	6	
18	Fitting, #8 SAE x #8 JIC	028076	2	
19	Fitting, #8 SAE x 1/4" JIC	036759	2	

9 HYDRAULIC SYSTEM

Hydraulic Log Turner

9.4 Hydraulic Log Turner

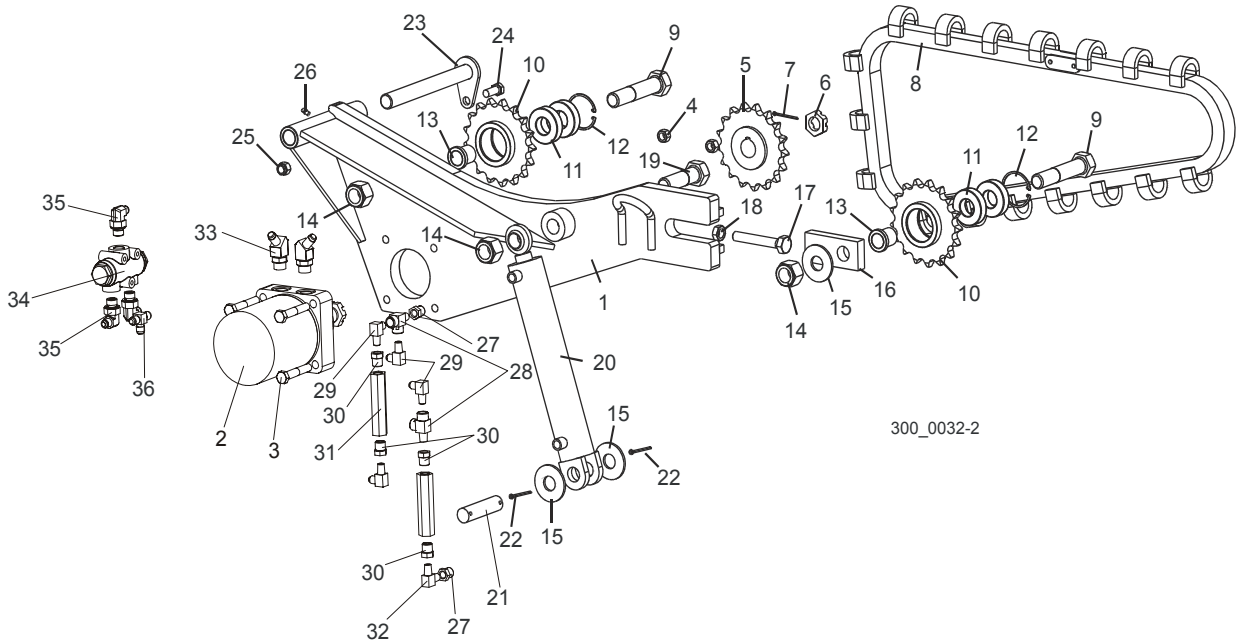

REF	DESCRIPTION (◆ Indicates Parts Available In Assemblies Only)	PART #	QTY.
	TURNER ASSEMBLY, HYDRAULIC LOG	034537	1
1	Arm Weldment, Hydraulic Log Turner	016873	1
2	Motor, MB29-02-08-AABP Hydraulic	018741	1
3	Bolt, 1/2-13 x 3" Hex Head Grade 5	F05008-23	4
4	Nut, 1/2-13 Hex Lock	F05010-3	4
5	Sprocket Weldment, Log Turner Drive	042192	1
6	Nut, Hydraulic Motor Castle	018741-2	1
7	Pin, 1/8" x 1 3/4" Cotter	F05012-43	1
8	Chain Weldment, Log Turner	042196	1
	Cog, Log Turner	042194	17
	Chain, #2080 Log Turner	042195	1
	Link, #2080H Master	016796	1
9	Bolt, 1-8 x 5" Hex Head Grade 8	F05004-132	2
	Sprocket Assembly, Idler	042193	2
10	Sprocket Weldment, Idler	042191	1
11	Bearing, 6206 25 Idler	P11035	2
12	Ring, 62mm #472 DIN Inside Retaining	F04254-12	1
13	Spacer, Idler Sprocket	042187	2
14	Nut, 1-8 Hex Lock	F05010-109	3
15	Washer, 1" SAE Flat	F05011-28	3
16	Plate, Log Turner Chain Tensioner	042188	1

17	Bolt, 5/8-11 x 4" Hex Head Full Thread Grade 5	F05009-31	1	
18	Nut, 5/8-11 Hex Jam	F05010-82	1	
19	Bolt, 1-8 x 3 1/2" Hex Head Grade 5	F05009-50	1	
20	Cylinder, 2" x 10" Welded Rod End Hydraulic	034267	1	
21	Pin, 1" x 3.88" Hydraulic Cylinder	S09251	1	
22	Pin, 3/16" x 1 1/2" Cotter	F05012-23	2	
23	Pin Weldment, Log Turner Mount	042331	1	
24	Bolt, 1/2-13 x 1 1/4" Hex Head Grade 5	F05008-37	1	
25	Nut, 1/2-13 Hex Nylon Lock	F05010-8	1	
26	Fitting, 1/4-28 Grease	P05060	1	
	Hydraulic Cylinder Connection Parts	094383	1	
27	Fitting, 3/8NPT - 1/4NPT Reducer	015490	2	
28	Fitting, C3759X4 Male Run Tee	P09141	2	
29	Fitting, 3/8JIC-1/4NPT 90L	015491	4	
30	Fitting, 3/8NPT - 1/4NPT Reducer	015490	6	
31	Valve, Log Side Support Sequence	015484	2	
32	Fitting, 90° #C3529X4 Male Pipe Elbow	P09140	1	
33	Fitting, 3/8"	034538	2	
34	Divider, MTDA O8-016M 1/2 / 1/2 Oil Flow	088191	1	
35	Fitting, 90 18x1.5 9/16-18 JIC Elbow	089992	2	
36	Fitting, 3/8JIC Tee	015487	1	

9.5 Hydraulic Log Side Supports

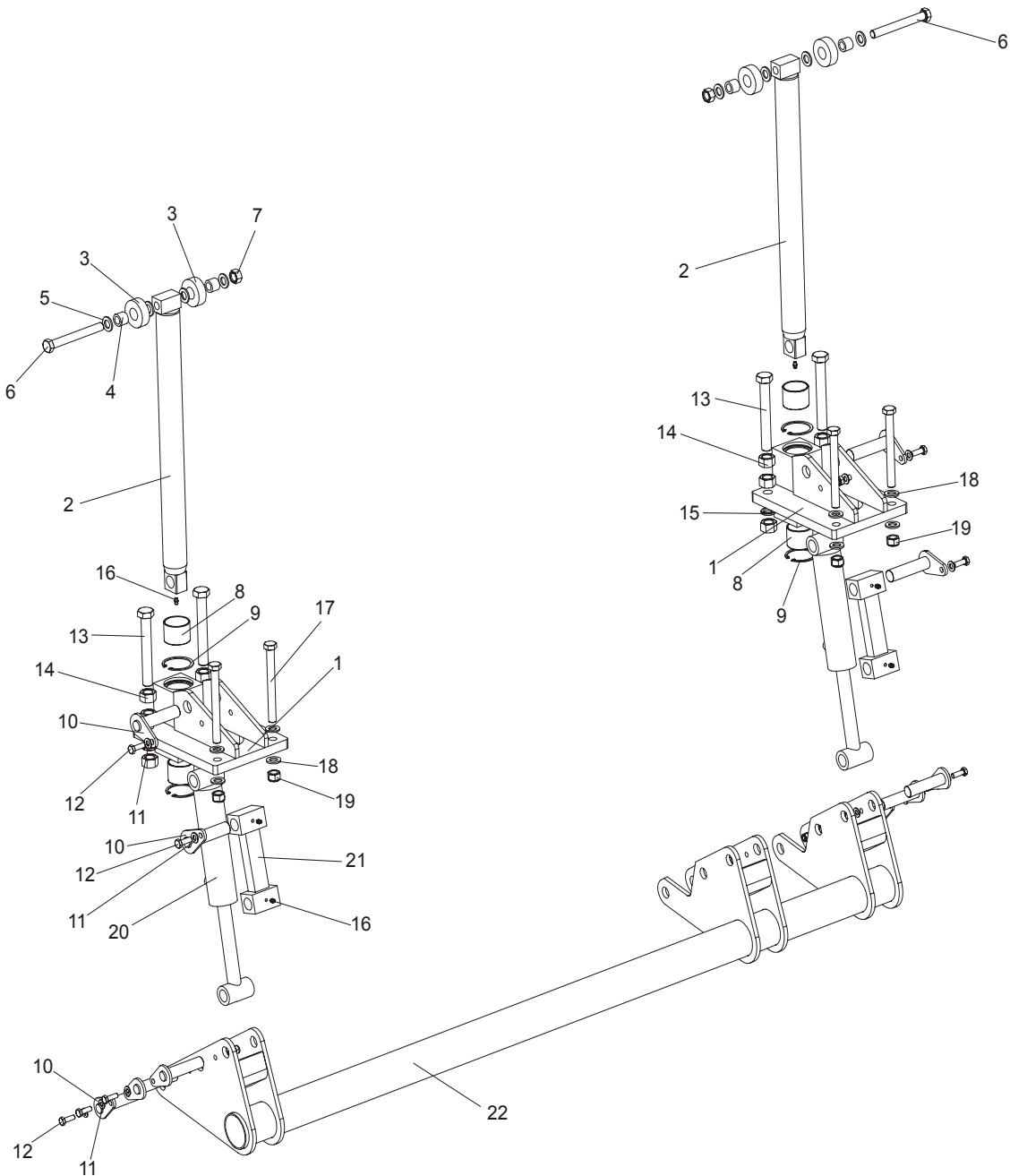

REF	DESCRIPTION (◆ Indicates Parts Available In Assemblies Only)	PART #	QTY.
	SUPPORT, LT70 VERTICAL LOG SIDE (2)	097519	2
1	Mount Weldment, LT70 Vertical Side Support Upper	094003-1	1
2	Rod Weldment, LT70 Vertical Side Support Complete	094011-1	1
3	Roller, LT70/300 Vertical Side Support Zinc-Plated	094013-1	2

4	Bushing, LT70/300 Verical Side Support Bronze	094012	2	
5	Washer, 17 Flat Zinc	F81058-1	4	
6	Bolt, M16x140-8.8 Hex Head Zinc	F81006-4	1	
7	Nut, M16-5.8 Hex Zinc	F81036-1	1	
8	Bushing, 5040BS Non-Greasable	088660	1	
9	Ring, 62W Inside Retaining	F81090-1	2	
10	Pin Weldment, Vertical Side Support Zinc-Plated	091197-1	5	
11	Washer, 10.5 Flat Zinc	F81055-1	5	
12	Bolt, M10x30-5.8 Hex Head Full Thread Zinc	F81003-2	5	
13	Bolt, ISO 4017 M20x150 8.8 Zinc-Plated	F81007-3	2	
14	Nut, M20-8 Hex Zinc	F81037-1	6	
15	Washer, 20.5 Split Lock Zinc	F81059-1	2	
16	Fitting, M6 Grease	086280	2	
17	Bolt, M16x160 -8.8 Hex Head Zinc	F81006-20	2	
18	Washer, 17 Flat Zinc	F81058-1	4	
19	Nut, M16-8 Hex Nylon Zinc Lock	F81036-2	2	
20	Cylinder, 28/150 1/4 NPT Port Hydraulic	094002	1	
21	Link Weldment, LT70 Vertical Side Support	094016-1	1	
22	MOUNT WELDMENT, LT70 VERTICAL SIDE SUPPORT LOWER	097289-1	1	

9.6 Hydraulic Log Clamp

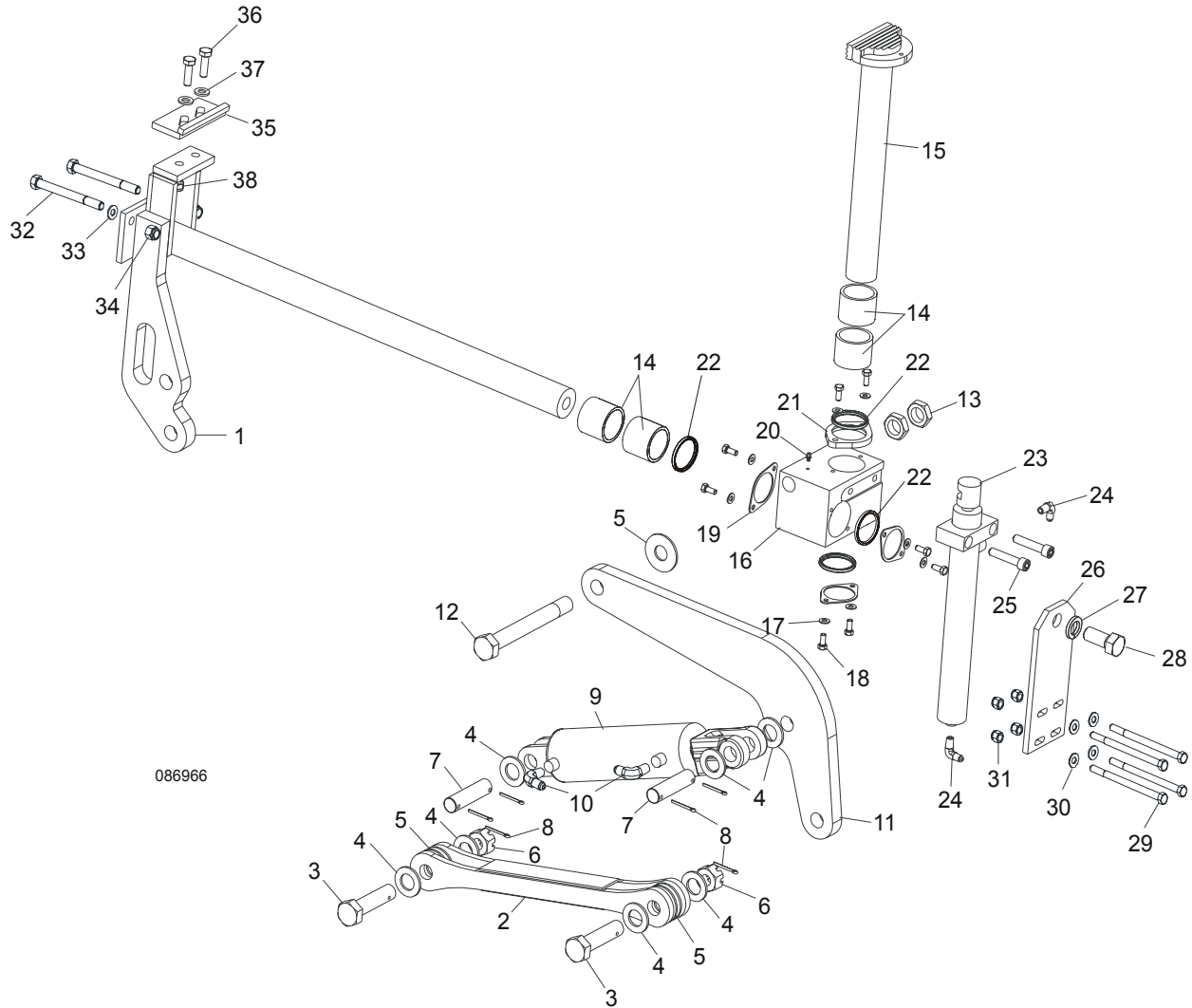

REF	DESCRIPTION (◆ Indicates Parts Available In Assemblies Only)	PART #	QTY.
	LOG CLAMP ASSEMBLY, TWO-PLANE	088658	1
1	Rod Weldment, Log Clamp Slide Painted	086967-1	1
2	Arm Weldment, Hydraulic Clamp Link Painted	086963-1	1
3	Pin, B 24x95/85 Clevis Zinc	F81049-2	1
4	Washer, 25 Flat Zinc	F81061-3	8
5	Washer, 25X63 Zinc-Plated	088585-1	5
6	Nut, M20-8-3 Hex Slotted Castle Zinc	F81037-3	2
7	Pin, Hydraulic Cylinder Zinc-Plated	086979-1	2

8	Pin, 6.3x45 Cotter Zinc	F81045-2	6	
9	Cylinder, CJ-S96-16-70/32/178 Hydraulic	088589	1	
10	Fitting, 90° Male Elbow	P09142	2	
11	Arm, Hydraulic Log Clamp Link Painted	086974-1	1	
12	Bolt, M24x217/39-8.8-B Hex Head Zinc	088586-1	1	
13	Nut, M24 -04-B Hex Thin Zinc	F81039-3	2	
14	Bushing, 5040BS Self-Lubricating	088660	4	
15	Rod Weldment, Log Clamp Vertical Painted	088582-1	1	
16	Block, Log Clamp Painted Steel	088591-1	1	
17	Washer, 8.4 Flat Zinc	F81054-1	8	
18	Bolt, M8x20-8.8-B Hex Head Full Thread Zinc	F81002-4	8	
19	Flange, Clamp Rod Wiper Painted	088887-1	3	
20	Fitting, 3/16" Straight Grease	P04107	1	
21	Flange, Clamp Rod Wiper Painted	088887-1	4	
22	Wiper, ZZ 50x60x7 INCO Log Clamp Rod	088587	4	
23	Cylinder, CJ-S169-16-40/22/254 Hydraulic	088590	1	
24	Fitting, 90° Male Elbow	P09142	2	
25	Screw, M12x55-8.8-B Hex Socket Head Cap Zinc	F81004-23	2	
26	Plate, Log Clamp Mount Painted	086975-1	1	
27	Washer, Z 22.5 Split Lock Zinc	F81059-4	1	
28	Bolt, M22x1.5x40-8.8-B Hex Head Full Thread Zinc	F81009-1	1	
29	Bolt, M10 x 125-8.8 Hex Head Zinc	F81003-18	4	
30	Washer, 10.5 Flat Zinc	F81055-1	4	
31	Nut, M10-8-B Hex Nylon Zinc Lock	F81033-1	4	
32	Bolt, M12 x 130-8.8 Carriage	F81004-26	2	
33	Washer, 13 Flat Zinc	F81056-1	2	
34	Nut, M12-8-B Hex Zinc	F81034-1	2	
	STOP ASSEMBLY, LOG CLAMP	K09485	1	
35	Stop Weldment, Hydraulic Log Clamp Painted	086980-1	1	
36	Bolt, M12 x 40 8.8 Hex Head Full Thread Zinc	F81004-4	2	
37	Washer, 13 Flat Zinc	F81056-1	2	
38	Nut, M12-8 Hex Nylon Zinc Lock	F81034-2	2	

9.7 Hydraulic Log Clamp, Standard

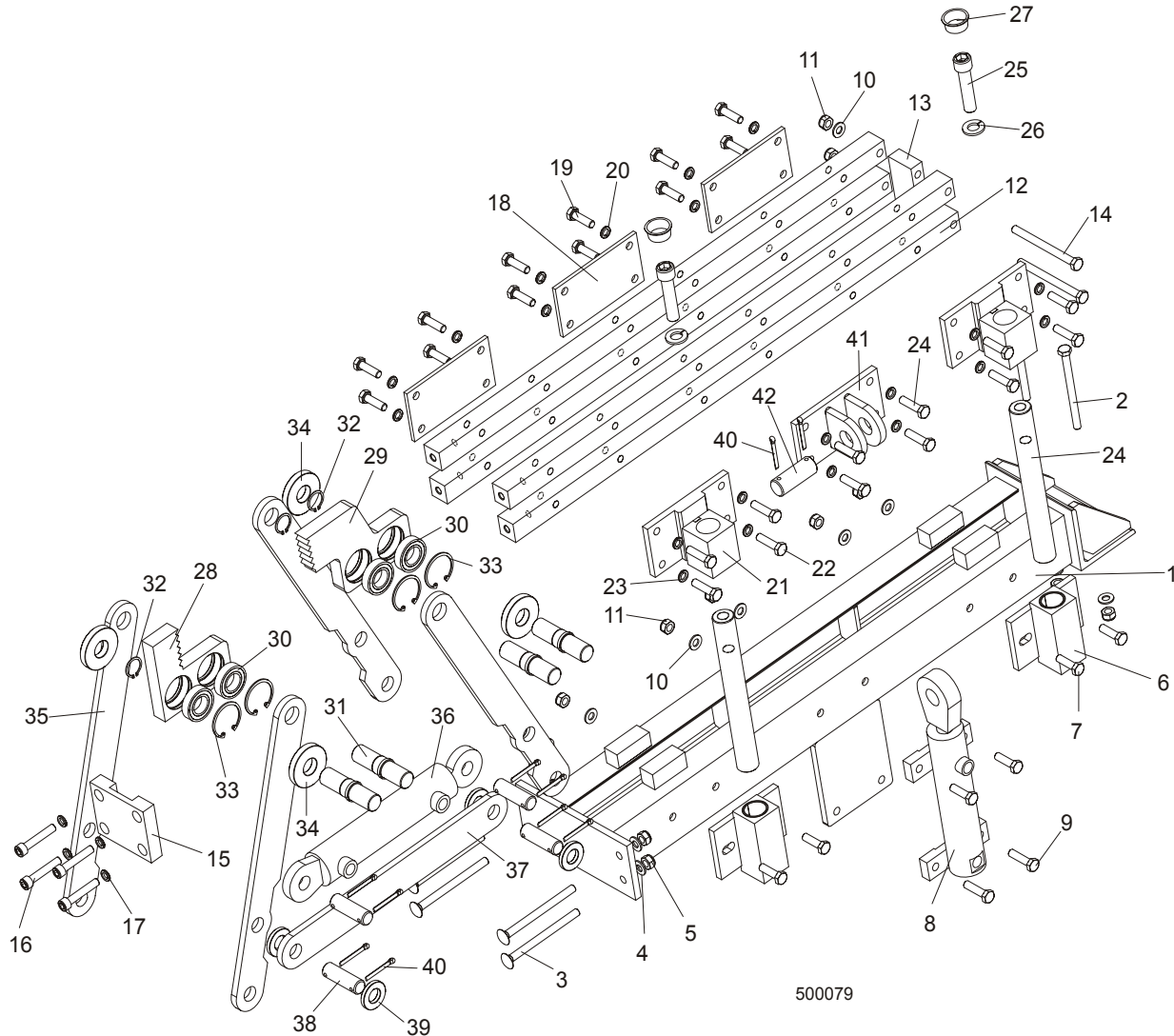

500079

REF	DESCRIPTION (◆ Indicates Parts Available In Assemblies Only)	PART #	QTY.
	CLAMP ASSEMBLY, HYDRAULIC	089545	2
1	Mount Weldment, Hydraulic Log Clamp	088654-1	1
2	Bolt, M10x125-8.8 Zinc Hex Head	F81003-18	2
3	Bolt, M10x130-8.8 Zinc Mushroom Head Square Neck	F81003-36	4
4	Washer, 10.5 Flat Zinc	F81055-1	6
5	Nut, M10-8-B Hex Nylon Zinc Lock	F81033-1	6
6	Block, Guide Pin	089835-1	2
7	Bolt, M10x35-8.8 Zinc Hex Head Full Thread	F81003-17	4
8	Cylinder,CJ7F-16-40/22 + UE2-40W Hydraulic	088662	1
9	Bolt, M10x40-8.8 Zinc Hex Head	F81003-16	4

10	Washer, M10 Flat Zinc	F81055-1	6	
11	Nut, M10-8-b Hex Nylon Zinc Lock	F81033-1	10	
12	Bar, Clamp Up/Down	089537-1	4	
13	Plate, Connecting	088645-1	1	
14	Bolt, M10x140-8.8 Zinc Hex Head	F81003-5	2	
15	Plate, Connecting	089533-1	1	
16	Bolt, M10x55-8.8 Zinc Hex Socket Head Cap	F81003-55	4	
17	Washer, 10.2 Split Lock Zinc	F81055-2	4	
18	Plate, Log Clamp Rear	089538-1	3	
19	Bolt, M10x35-8.8 Zinc Hex Head Full Thread	F81003-17	12	
20	Washer, 10.2 Split Lock Zinc	F81055-2	12	
21	Bracket, Guide Pin Mount	089536-1	2	
22	Bolt, M10x40-8.8 Zinc Hex Head Full Thread	F81003-16	8	
23	Washer, 10.2 Split Lock Zinc	F81055-2	8	
24	Pin, Clamp Up/Down Guide	088631	2	
25	Screw, M16x55-8.8 Zinc Hex Socket Head Cap	F81006-18	2	
26	Washer, 16.3 Split Lock Zinc	F81058-2	2	
27	Plug, M33 Thread	089839	2	
	Jaw, Log Clamp Left - Complete	094700	1	
28	Jaw, Log Clamp Left	093464-1	1	
30	Bearing, 6005 2RS CX	089652	4	
31	Shaft, Clamp Jaw Guide	088620-1	4	
32	Ring, Z24 Spring Retaining	089654	4	
33	Ring, W47 Spring Retaining	089653	4	
	Jaw, Log Clamp Right - Complete	094701	1	
29	Jaw, Log Clamp Right	093465-1	1	
30	Bearing, 6005 2RS CX	089652	4	
31	Shaft, Clamp Jaw Guide	088620-1	4	
32	Ring, Z24 Spring Retaining	089654	4	
33	Ring, W47 Spring Retaining	089653	4	
34	Washer, Clamp Jaw Spacer	089542	4	
35	Bar, Clamp In/Out Side	088622-1	4	
36	Cylinder, SJ2F-40/22/145 Hydraulic	088661	1	
37	Bar, Clamp In/Out Lower	088623-1	1	
38	Pin, 20X75	088657-1	4	
39	Spacer, Lower	089541	4	
40	Pin, S-Zn 5x40 Cotter	F81043-31	10	
41	Bracket, Vertical Cylinder Mount Upper	089540-1	1	
42	Pin, 25X75	088659-1	1	

9.8 Hydraulic Log Clamp, Optional

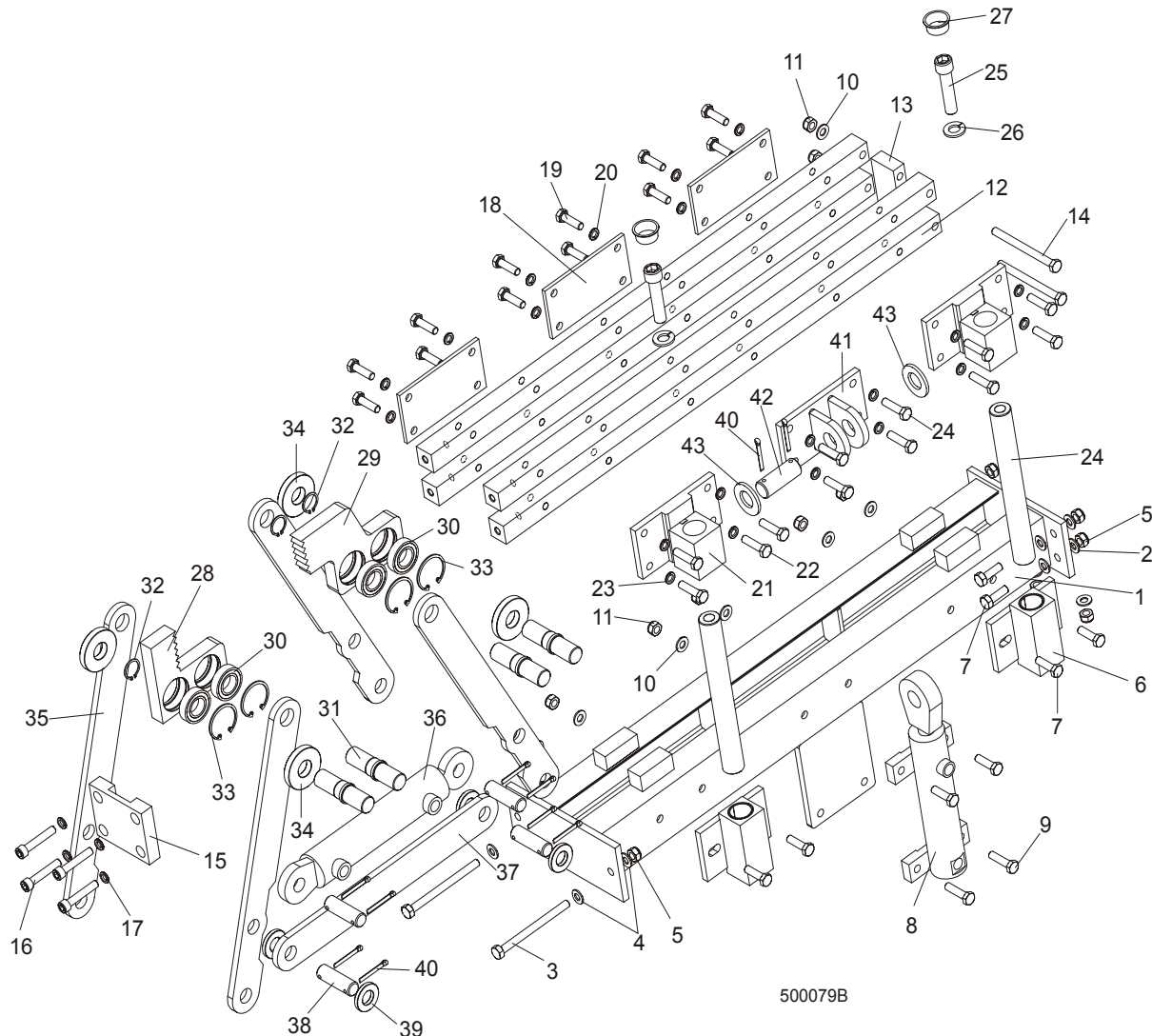

REF	DESCRIPTION (◆ Indicates Parts Available In Assemblies Only)	PART #	QTY.
	HYDRAULIC LOG CLAMP ASSEMBLY	094950	2
1	Mount Weldment, Hydraulic Log Clamp	094951-1	1
2	Washer, M10 Split Lock Zinc	F81055-2	4
3	Bolt, M10x125-8.8 Zinc Hex Head	F81003-18	2
4	Washer, 10.5 Flat Zinc	F81055-1	6
5	Nut, M10-8-B Hex Nylon Zinc Lock	F81033-1	6
6	Block Weldment, Log Clamp Up/Down Lower Painted	089835-1	2
7	Bolt, M10x35-8.8 Hex Head Full Thread Zinc	F81003-17	8
8	Cylinder, CJ7F-16-40/22 + UE2-40W Hydraulic	088662	1
9	Bolt, M10x40-8.8 Hex Head Full Thread Zinc	F81003-16	4

10	Washer, 10.5 Flat Zinc	F81055-1	6	
11	Nut, M10-8-B Hex Nylon Zinc Lock	F81033-1	10	
12	Bar, Log Clamp Main Painted	089537-1	4	
13	Block, Main Bar Spacer Painted	088645-1	1	
14	Bolt, M10x120-8.8 Hex Head Zinc	F81003-47	2	
15	Plate Weldment, Main Bar Mounting Painted	089533-1	1	
16	Screw, M10x40-8.8 Hex Socket Head Cap Zinc	F81003-22	4	
17	Washer, 10.2 Split Lock Zinc	F81055-2	4	
18	Plate, Log Clamp Rear Painted	089538-1	3	
19	Bolt, M10x35-8.8 Hex Head Full Thread Zinc	F81003-17	12	
20	Washer, 10.2 Split Lock Zinc	F81055-2	12	
21	Block Weldment, Log Clamp Up/Down Upper	089536-1	2	
22	Bolt, M10x40-8.8 Hex Head Full Thread Zinc	F81003-16	8	
23	Washer, 10.2 Split Lock Zinc	F81055-2	8	
24	Pin, Log Clamp Up/Down	088631	2	
25	Screw, M16x55-8.8 Hex Socket Head Cap Zinc	F81006-18	2	
26	Washer, 16.3 Split Lock Zinc	F81058-2	2	
27	Plug, M33 Thread	089839	2	
	Jaw, Log Clamp Left - Complete	094700	1	
28	Jaw, Log Clamp Left	093464-1	1	
30	Bearing, 6005 2RS CX	089652	4	
31	Shaft, Log Clamp Jaw	088620-1	4	
32	Ring, Z24 Outside Retaining	089654	4	
33	Ring, W47 Inside Retaining	089653	4	
	Jaw, Log Clamp Right - Complete	094701	1	
29	Jaw, Log Clamp Right	093465-1	1	
30	Bearing, 6005 2RS CX	089652	4	
31	Shaft, Log Clamp Jaw	088620-1	4	
32	Ring, Z24 Outside Retaining	089654	4	
33	Ring, W47 Inside Retaining	089653	4	
34	Washer, Clamp Jaw Spacer	089542	4	
35	Arm, Log Clamp In/Out Painted	088622-1	4	
36	Cylinder, SJ2F-40/22/145 Hydraulic	088661	1	
37	Link, Log Clamp In/Out Arm Painted	088623-1	1	
38	Pin, 20x75 Zinc-Plated	088657-1	4	
39	Washer, Lower Spacer	089541	4	
40	Washer, M20 Flat Zinc	F81059-2	10	
41	Bracket, Up/Down Cylinder Mount Upper	089540-1	1	
42	Pin, 25x75 Zinc-Plated	088659-1	1	
43	Washer 28 Fe/Zn5	F81061-1	2	

9 HYDRAULIC SYSTEM

Hydraulic Toe Board

9.9 Hydraulic Toe Board

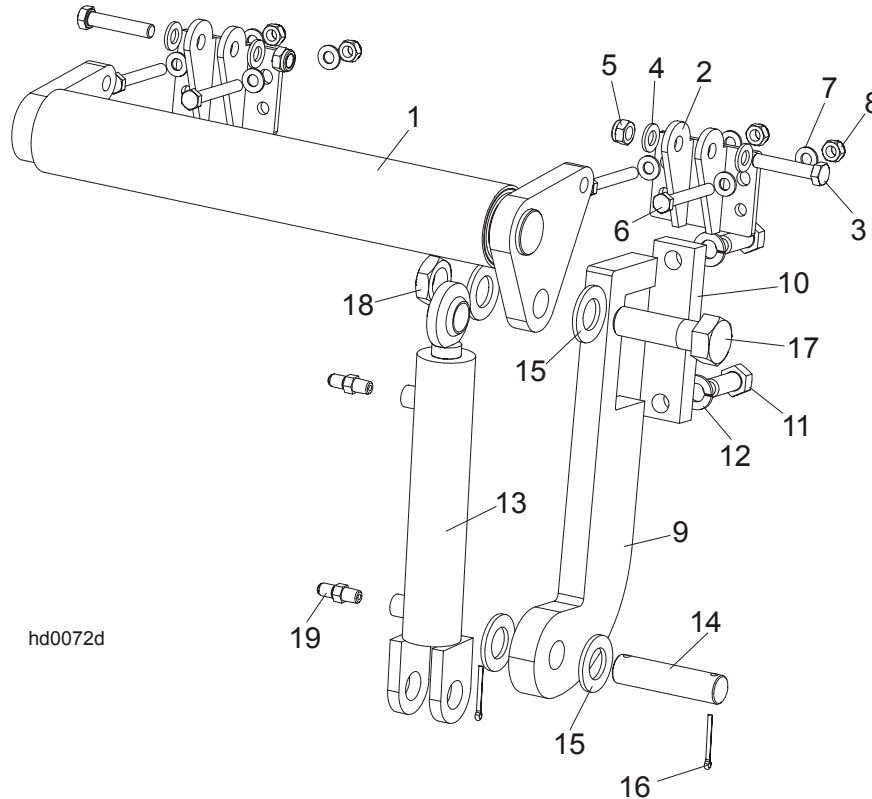

REF	DESCRIPTION (◆ Indicates Parts Available In Assemblies Only)	PART #	QTY.
	FRONT HYDRAULIC TOE BOARD	092613	1
	REAR HYDRAULIC TOE BOARD	092634	1
1	Toe Board Weldment, Front Hydraulic Painted	092612-1	1
	Toe Board Weldment, Rear Hydraulic Painted	086253-1	1
2	Bracket, Toe Board Roller Mount	087903-1	4
3	Bolt, M12x60-8.8 Hex Head Zinc	F81004-5	4
4	Washer, 13 Flat Zinc	F81056-1	8
5	Nut, M12-8 Hex Nylon Zinc Lock	F81034-2	4
6	Bolt, M10x75-8.8 Hex Head Zinc	F81003-15	8
7	Washer, 10.5 Flat Zinc	F81055-1	16
8	Nut, M10-8-B Hex Nylon Zinc Lock	F81033-1	8
9	Bracket, Toe Board Cylinder Mount Painted	087729-1	2
10	Plate, Toe Board Cylinder Mount	090086-1	2
11	Bolt, M16x40-8.8 Hex Head Full Thread Zinc	F81006-13	4
12	Washer, 16.3 Split Lock Zinc	F81058-2	4
13	Cylinder, CJ-S170-16-40/25/152 Hydraulic	088681	2
14	Pin, Hydraulic Cylinder Zinc-Plated	086979-1	2
15	Washer, 28 Flat Zinc	F81061-1	8

HYDRAULIC SYSTEM

Hydraulic Toe Board

9

16	Pin, 3/16x1.5" Cotter Zinc	F05012-23	4	
17	Bolt, 1"-8 x 3 1/4 Hex Head Grade 5	F05009-51	2	
18	Nut, 1"-14	F05010-117	2	
19	Fitting, C5205x4x4 Male	P09143	4	