

Wood-Mizer[®] Sawmill

Safety, Setup, Operation & Maintenance Manual

LT70AC Remote

rev. A1.00



Safety is our #1 concern! Read and understand all safety information and instructions before operating, setting up or maintaining this machine.

October 2004

Form #996

Table of Contents

Section-Page

SECTION 1	SAFETY	1-II
1.2	Safety Instructions	1-iii
SECTION 2	SERVICING THE SAWMILL	2-1
2.1	If You Need To Order Parts	2-1
2.2	Customer and Sawmill Identification	2-2
2.3	If You Need Service	2-4
SECTION 3	SETUP	3-1
3.1	Site Preparation	3-1
3.3	Replacing The Blade	3-4
3.4	Tensioning The Blade	3-5
3.5	Tracking The Blade	3-6
3.6	Starting The Motor	3-9
3.7	Initial Control Programming	3-10
SECTION 4	OPERATION	4-1
4.1	Control Overview	4-1
4.2	Controlling The Sawmill	4-4
SECTION 5	MAINTENANCE	5-1
5.1	Wear Life	5-1
5.2	Blade Guides	5-2
5.3	Sawdust Removal	5-4
5.4	Carriage Track, Wiper & Scrapers	5-5
5.5	Vertical Mast Rails	5-6
5.6	Miscellaneous	5-7
5.7	Drive Belt Adjustment	5-8
5.8	Hydraulic System	5-10
5.9	Up/Down System	5-11
5.10	Power Feed System	5-13
SECTION 6	TROUBLESHOOTING GUIDE	6-1
6.1	Sawing Problems	6-1
6.2	Power Feed Problems	6-4
6.3	Hydraulic Problems	6-6
6.4	Motor And Drive Pulleys Alignment (AC Sawmills Only)	6-10
6.5	Power Feed Mechanical Test	6-11
6.6	Hydraulic Pressure Test	6-12

Table of Contents

Section-Page

SECTION 7 SAWMILL ALIGNMENT

7-1

7.1	Routine Alignment Procedure	7-1
7.2	Align Side Supports	7-14
7.3	Complete Alignment Procedure	7-15

SECTION 8 SPECIFICATIONS

8-1

8.1	Log Capacity	8-1
8.2	Overall Dimensions	8-1
8.3	Motor Specifications	8-2
8.4	Chains	8-3
8.5	Hydraulic System	8-3
8.6	Belt Sizes	8-3
10.7	Wykaz komponentów elektrycznych	9-2

ABOUT THIS MANUAL

This manual is to replace or to be used with all previous information received on the Wood-Mizer® * sawmill. All future mailings will be an addition to or a revision of individual sections of this manual as we obtain new information.

The information and instructions given in this manual do not amend or extend the limited warranties for the equipment given at the time of purchase.

For general information regarding Wood-Mizer and our “Forest to Final Form” products, please refer to the All Products Catalog in your support package.



MILL COMPONENTS

*Wood-Mizer® is a registered trademark of Wood-Mizer Products, Inc.
Sawmill U.S. Patent Nos.: 4,559,858, 4,878,411 & 4,930,386
Brevet au Canada Nos.: 1,200,180 & 1,211,684

SECTION 1 SAFETY

1.1 Safety Symbols

The following symbols and signal words call your attention to instructions concerning your personal safety. Be sure to observe and follow these instructions.



DANGER! indicates an imminently hazardous situation which, if not avoided, will result in death or serious injury.



WARNING! suggests a potentially hazardous situation which, if not avoided, could result in death or serious injury.



CAUTION! refers to potentially hazardous situations which, if not avoided, may result in minor or moderate injury or damage to equipment.



IMPORTANT! indicates vital information.

NOTE: gives helpful information.



Warning stripes are placed on areas where a single decal would be insufficient. To avoid serious injury, keep out of the path of any equipment marked with warning stripes.

1.2 Safety Instructions

NOTE: ONLY safety instructions regarding personal injury are listed in this section. Caution statements regarding only equipment damage appear where applicable throughout the manual.

OBSERVE SAFETY INSTRUCTIONS



IMPORTANT! Read the entire Operator's Manual before operating the sawmill. Take notice of all safety warnings throughout this manual and those posted on the machine. Keep this manual with this machine at all times, regardless of ownership.

Also read any additional manufacturer's manuals and observe any applicable safety instructions including dangers, warnings, and cautions.

Only persons who have read and understood the entire operator's manual should operate the sawmill. The sawmill is not intended for use by or around children.

IMPORTANT! It is always the owner's responsibility to comply with all applicable federal, state and local laws, rules and regulations regarding the ownership and operation of your Wood-Mizer sawmill. All Wood-Mizer mill owners are encouraged to become thoroughly familiar with these applicable laws and comply with them fully while using the mill.



WEAR SAFETY CLOTHING



WARNING! Secure all loose clothing and jewelry before operating the sawmill. Failure to do so may result in serious injury or death.

WARNING! Always wear gloves and eye protection when handling bandsaw blades. Changing blades is safest when done by one person! Keep all other persons away from area when coiling, carrying or changing a blade. Failure to do so may result in serious injury.

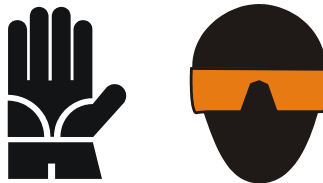

WARNING! Always wear eye, ear, respiration and foot protection as well as safety clothing when operating or servicing the sawmill.



KEEP SAWMILL AND AREA AROUND SAWMILL CLEAN



DANGER! Maintain a clean and clear path for all necessary movement around the mill and lumber stacking areas. Failure to do so will result in serious injury.

HANDLE FUEL/LUBRICANTS SAFELY



WARNING! Use **ONLY** water or approved additives with the lube system. Never use flammable fuels or liquids. If these types of liquids are necessary to clean the blade, remove it and clean with a rag. Failure to do so may result in serious injury or death.

DISPOSE OF SAWING BY-PRODUCTS PROPERLY



IMPORTANT! Always properly dispose of all sawing by-products, including sawdust and other debris.

CAUTIONS FOR SAWMILL SETUP



WARNING! Securely fasten the feet of the sawmill to the floor before operating the sawmill. Failure to do so may result in serious injury or death.

CHECK SAWMILL/BLADES BEFORE OPERATION

 **DANGER!** Make sure all guards and covers are in place and secured before operating the sawmill. Failure to do so may result in serious injury.





 **WARNING!** Blade guide alignment is essential for optimal cutting performance, blade life and safety. Failure to check and maintain proper blade guide alignment will result in stress cracks forming in the blade. These cracks will lead to premature blade breakage. If the blade breaks during operation and the blade has multiple stress cracks, the blade could shatter into several pieces and escape from the protective guards of the sawmill. Small blade pieces projected into the area around the sawmill creates a safety hazard for the operator and any bystanders surrounding the mill.

WARNING! DO NOT use blades with stress cracks. Blades with stress cracks can shatter causing bodily injury and/or machine damage.

KEEP PERSONS AWAY

 **DANGER!** Keep all persons out of the path of moving equipment and logs when operating sawmill or loading and turning logs. Failure to do so will result in serious injury.

 **DANGER!** Always be sure all persons are out of the path of the blade before starting the motor. Stop the motor immediately when any person is nearby the sawmill. Failure to do so will result in serious injury.

 **DANGER!** To make access to the sawmill difficult for bystanders, mount a fence around the machine. The fence should be 1 to 1.2 m high and should be mounted at least 1.4 m away from the sawmill.

KEEP HANDS AWAY



DANGER! Always shut off the sawmill and wait until the blade wheels have come to a complete stop before changing the blade. Failure to do so will result in serious injury.

DANGER! Always keep hands away from moving bandsaw blade. Failure to do so will result in serious injury.

DANGER! Always be aware of and take proper protective measures against rotating shafts, pulleys, fans, etc. Always stay a safe distance from rotating members and make sure that loose clothing or long hair does not engage rotating members resulting in possible injury.



WARNING! Always stop the blades when the sawmill is not cutting. Failure to do so may result in serious injury.

WARNING! Do not for any reason adjust the drive belts with the motor running. Doing so may result in serious injury.

WARNING! Always keep clear of exiting sawdust. Keep hands, feet and any other objects away from the sawdust chute when operating sawmill. Failure to do so may result in serious injury.

USE PROPER PROCEDURE WHEN CONDUCTING ELECTRICAL SAFETY CHECKS AND MAINTENANCE



DANGER! Make sure all electrical installation, service and/or maintenance work is performed by a qualified electrician and is in accordance with applicable electrical codes.

DANGER! Hazardous voltage inside the electric sawmill disconnect box, starter box, and at the motor can cause shock, burns, or death. Disconnect and lock out power supply before servicing! Keep all electrical component covers closed and securely fastened during mill operation.



WARNING! Consider all electrical circuits energized and dangerous.

WARNING! Never assume or take the word of another person that the power is off; check it out and lock it out.

WARNING! Do not wear rings, watches, or other jewelry while working around an open electrical circuit.

WARNING! Before performing service near moving parts such as blades, pulleys, motors, belts and chains, first turn the key switch to the OFF (#0) position and remove the key. If the key is turned on and moving parts activated, serious injury may result.

WARNING! Remove the blade before performing any service to the motor or sawmill. Failure to do so may result in serious injury.

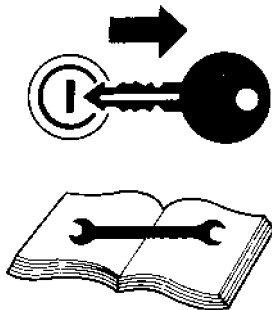

KEEP SAFETY LABELS IN GOOD CONDITION

 **IMPORTANT!** Always be sure that all safety decals are clean and readable. Replace all damaged safety decals to prevent personal injury or damage to the equipment. Contact your local distributor, or call your Customer Service Representative to order more decals.

 **IMPORTANT!** If replacing a component which has a safety decal affixed to it, make sure the new component also has the safety decal affixed.

USE CAUTION WHEN WORKING WITH HEAVY LOGS

 **WARNING!** Always make sure log is clamped securely before sawing. Failure to do so may result in serious injury or death.

AUTOMATIC BOARD RETURN SAFETY

 **DANGER!** Keep all persons out of the path of returning boards. Failure to do so will result in serious injury.

POWER FEED AND UP/DOWN SYSTEM SAFETY

 **DANGER!** If leaving the blade engaged for maximum production rates, make sure the off-bearer stays out of the path of the blade. Failure to do so will result in serious injury or death.

 **CAUTION!** Be sure the transducer sensor is adjusted properly before raising or lowering the saw head against the upper or lower travel limits. Failure to do so may result in damage to the machine.

SECTION 2 SERVICING THE SAWMILL

Wood-Mizer is committed to providing you with the latest technology, best quality and strongest customer service available on the market today. We continually evaluate our customers' needs to ensure we're meeting current wood-processing demands. Your comments and suggestions are welcome.

2.1 If You Need To Order Parts

From Europe call our European Headquarters and Manufacturing Facility in Kolo, Poland at **+48-63-2626000** or **+48-3912-1319**. From the continental U.S., call our toll-free Parts hotline at **1-800-448-7881**. Please have the vehicle identification number and your customer number ready when you call. Wood-Mizer will accept these methods of payment:

- Visa, Mastercard, or Discover
- COD
- Prepayment
- Net 15 (with approved credit)

Be aware that shipping and handling charges may apply. Handling charges are based on size and quantity of order. In most cases, items will ship on the day they are ordered. Second Day and Next Day shipping are available at additional cost.

2.2 Customer and Sawmill Identification

Each Wood-Mizer sawmill has a model number and a 17-digit Vehicle Identification Number (VIN). In addition, when you pick up your mill, you will receive a customer number. These three numbers will help expedite our service to you. Please locate them now and write them below so you have quick, easy access to them. See the following figures for model number and V.I.N. descriptions and locations.

(To be filled in by purchaser)

Mill Model _____
 Mill VIN _____
 Customer No. _____



MODEL NUMBER DESCRIPTION

See below for a description of the V.I.N.

Company Identification Number 456=Wood-Mizer Indiana	Weight Class; A=Under 3,000 lbs B=3,001-4,000 lbs C=4,001-5000 lbs	Product No.: 1=LT15, 2=LT20, 4=LT40 Series, 7=LT70 Series	Length of the Trailer; 20=20 Ft., 24=24', 35=35'	Number of axles on the trailer	Check Digit Add all the numbers and divide by 11	Year of Manufacture; Y=2001, Z=2002, A=2003, B=2004, C=2005, D=2006	State of Manufacture N=Indiana, P=Poland	Month of Manufacture A=January, B=February, C=March, etc...	Revision Level	Sequence Number Ranging from 000-999	End of 17-Digit VIN	Revision Level (Repeated)	Two-Digit Minor Revision Level
456	A	7	24	1	X	S	N	A	F9	017	F9	.01	

V.I.N. DESCRIPTION.

The model number and V.I.N. can be found in the following locations.

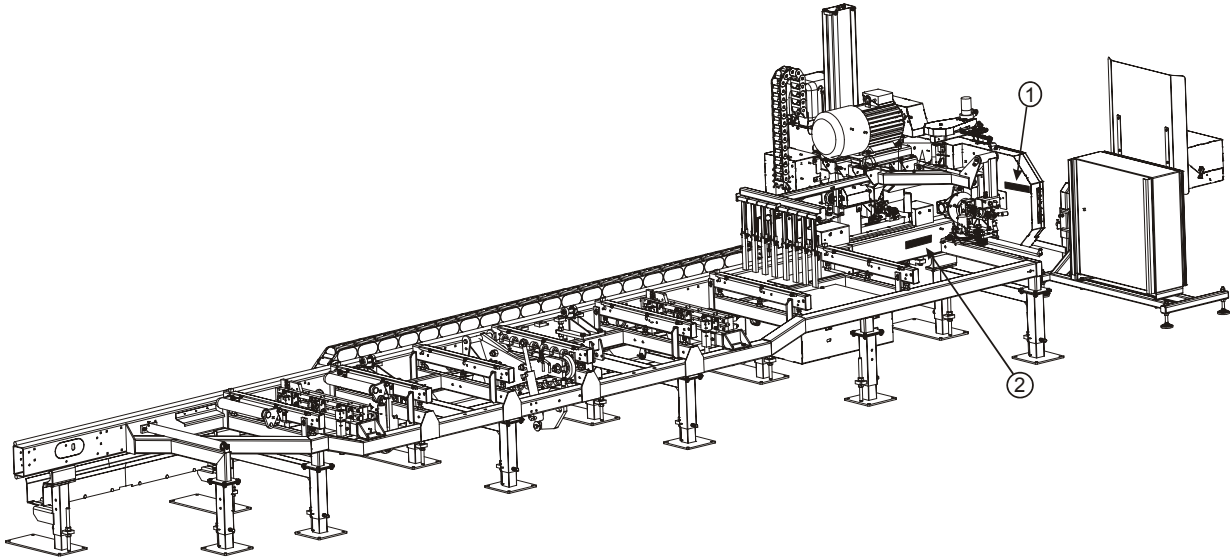

MODEL NUMBER AND V.I.N. LOCATIONS

2 Servicing The Sawmill

If You Need Service

2.3 If You Need Service

From Europe call our European Headquarters and Manufacturing Facility in Kolo, Poland at **+48-63-2626000** or **+48-3912-1319**. From the continental U.S., call us toll-free at **1-800-525-8100**. Ask to speak with a Customer Service Representative. Please have your vehicle identification number and your customer number ready when you call. The Service Representative can help you with questions about alignment of your mill, blade sharpening, or cutting a particular species of wood. He also can schedule you for a service call.

Office Hours: All times are Eastern Standard Time. Please remember that Indiana does not go on Daylight Savings Time in the summer.

Country	Monday - Friday	Saturday	Sunday
U.S., Indiana	8 a.m. to 5 p.m.	8 a.m. to 4 p.m.	Closed
Poland	8 a.m. to 4:30 p.m.	8 a.m. to 1 p.m.	Closed



IMPORTANT! Read the entire Operator's Manual before operating the sawmill. Take notice of all safety warnings throughout this manual and those posted on the machine. Keep this manual with this machine at all times, regardless of ownership.

SECTION 3 SETUP

3.1 Site Preparation



IMPORTANT! This information is provided so that you may have your site prepared for installation of your electric sawmill. In order to properly install your sawmill, you need to:

- 1. Prepare a firm, level area where the sawmill can be anchored.** There should be enough room around the sawmill for operators, sawdust removal, log loading and board removal. A cement pad with 1/2" diameter anchor bolts is recommended. The cement pad should be rated to support 6350 lbs./sq.ft. at each sawmill foot position.

The design of your site layout should be determined at the time of purchase.

The sawmill is designed for indoor operation and should be fully protected from outdoor elements.

- 2. Have a qualified electrician install the power supply before receipt of your sawmill.** The power supply should be installed as close to the machine as possible and must meet the enclosed specifications concerning wire size, fused disconnect, and voltage. The electrical installation must also meet local codes.

See Table 3-1. Power Supply Specifications for LT70 Remote Sawmills

3-Phase Volts	Fuse Disconnect	Time Delay Fuse	Suggested Wire Size
400 VAC	100 Amps	63 Amps	10 mm ² up to 15 m long

TABLE 3-1

- 3. Have a qualified electrician present when the sawmill is to be installed.** All relevant motor specifications and wiring information is provided. When scheduling an electrician for the day of installation, please confirm that they have enough of the proper size cable (wiring), as shown above. Many electricians may not stock this cable, which could seriously delay installation and training.

3 SETUP

Site Preparation

See Table 3-2. This table lists the 25 horsepower motor specifications for your reference.

25 HP Electric Motor Specifications	
Horsepower	25 (18.5kW)
RPM	2930
Volts	400
Amps	33.8
Ambient temperature	-15° to +40° C
Insulation Class	F
PH	3
Protection Degree	IP55
Duty	Continuous

TABLE 3-2

3.2 Sawmill Installation

Position the sawmill approximately 10 inches (250 mm) from the operator station. The operator station may be moved in the horizontal direction slightly to obtain the desired view of the sawmill.

After the sawmill is positioned, make sure the horizontal locking bolt and top adjustment nut on each leg is loose. Anchor the sawmill to the floor with 1/2" anchor bolts and nuts. At some foot locations, you may not be able to drill all four anchor bolt holes. Use at least two holes at each foot location.

Remove the saw head rest assembly located under the outer side of the saw head and the saw head rest block located under the inner side of the saw head.

See Figure 3-1.

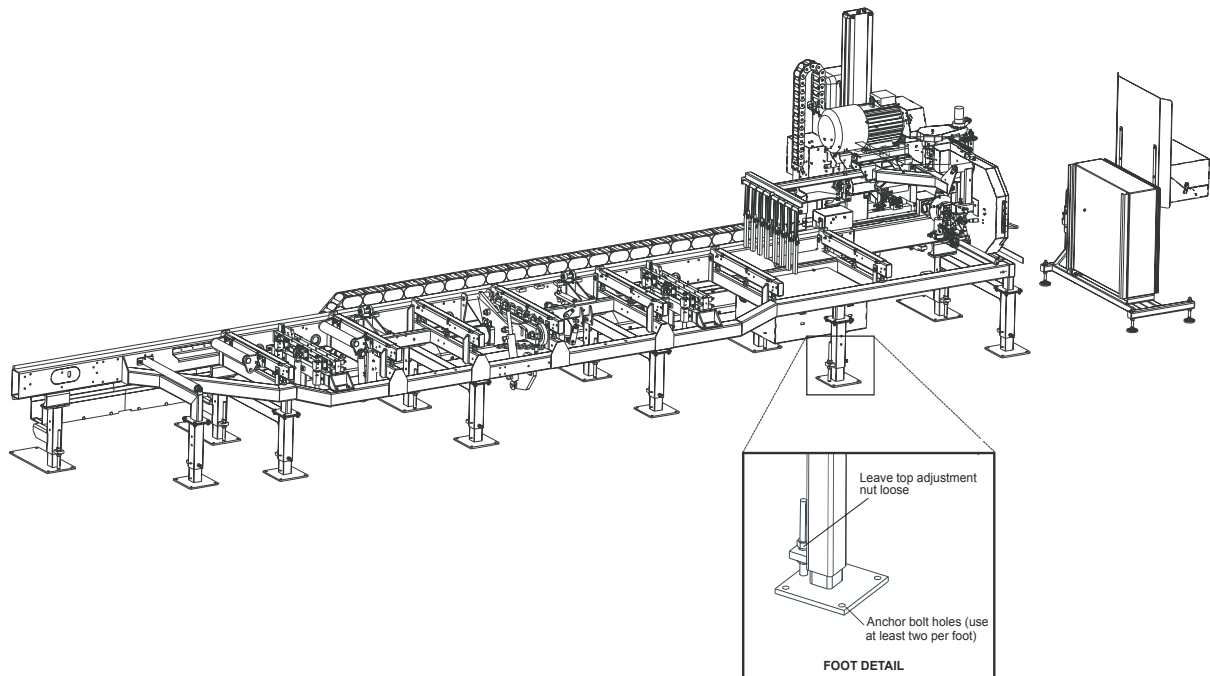

FIG. 3-1

3.3 Replacing The Blade



DANGER! Always shut off the sawmill motor before changing the blade. Failure to do so will result in serious injury.



WARNING! Always wear gloves and eye protection when handling bandsaw blades. Changing blades is safest when done by one person! Keep all other persons away from area when coiling, carrying or changing a blade. Failure to do so may result in serious injury.

Adjust the blade guide arm all the way open.

Open the two blade housing covers that cover the blade wheels. Turn the blade tension handle to release the blade tension until the wheel is pulled in and the blade is lying loose in the blade housing. Lift the blade out of the blade housing.

When installing a blade, make sure the teeth are pointing the correct direction. The teeth should be pointing toward the vertical mast of the mill when you are looking at the blade below the blade wheels. Install the blade so it is lying around the wheels.



CAUTION! Be careful when placing the blade between the blade guide inserts. If the blade hits one of the inserts hard enough, it could damage the insert.

Position 1 1/4" wide blades on the wheels so the gullet is 1/8" (3.0 mm) out from the front edge of the wheel. Position 1 1/2" wide blades on the wheels so the gullet is 3/16" (4.5 mm) out from the edge of the wheel.

Close the blade housing covers.

Next, turn the tension handle until the blade is tensioned correctly.

3.4 Tensioning The Blade

Before tensioning the blade, check the air pressure gauge to see that the air tension system is properly charged. The gauge should read 50 PSI, i.e., .34 MPa (yellow colour) with the blade tension completely released. To add air pressure, remove the air valve stem cover and attach an air pump to the air valve. Add air until the gauge reads 50 PSI. To release air, push in the valve stem. Replace the air valve stem cover when finished adjusting the air pressure.

To tension the blade, turn the tension handle clockwise until the air pressure gauge reads 60 PSI, i.e., .4 MPa (green colour).

See Figure 3-2.

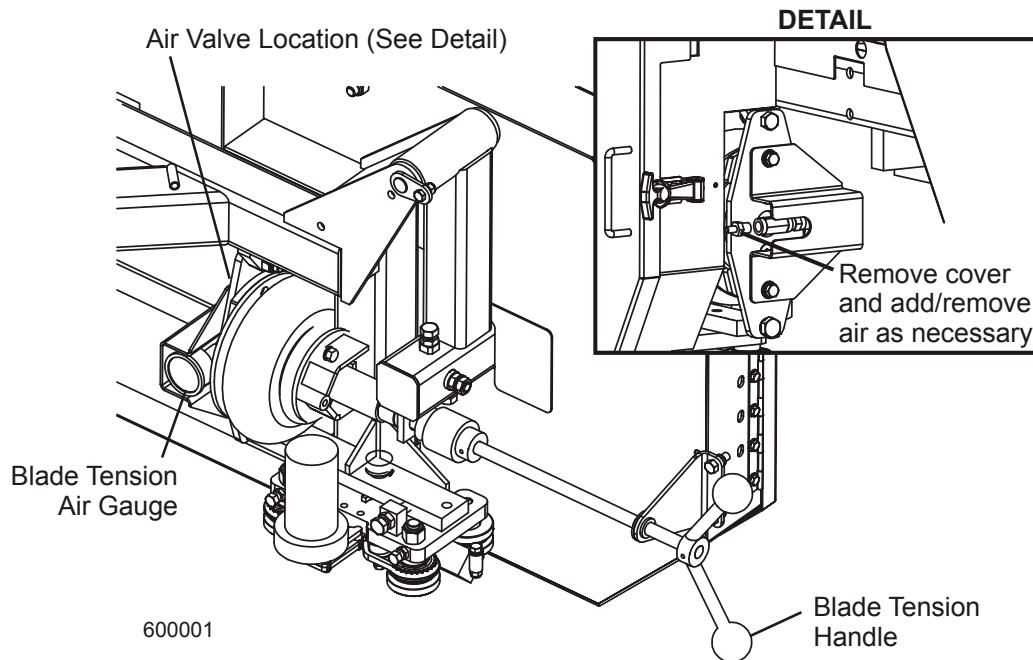

FIG. 3-2

The tension gauge should be checked occasionally when adjusting the cant control or while cutting. Ambient temperature changes will cause tension to change. Adjust the tension handle as necessary to maintain the recommended tension level.

3.5 Tracking The Blade

1. Turn the key switch to the #2 position.
2. Manually spin one of the blade wheels until the blade positions itself on the blade wheels.
3. Check that if the blade is properly positioned on the blade wheels.

See Figure 3-3. Position 1 1/4" wide blades so the gullet is 1/8" (3.0 mm) out from the front edge of the blade wheel ($\pm 1/16$ [1.5 mm]). Position 1 1/2" blades so the gullet is 3/16" (4.5 mm) out from the edge of the blade wheel ($\pm 1/16$ [1.5 mm]).

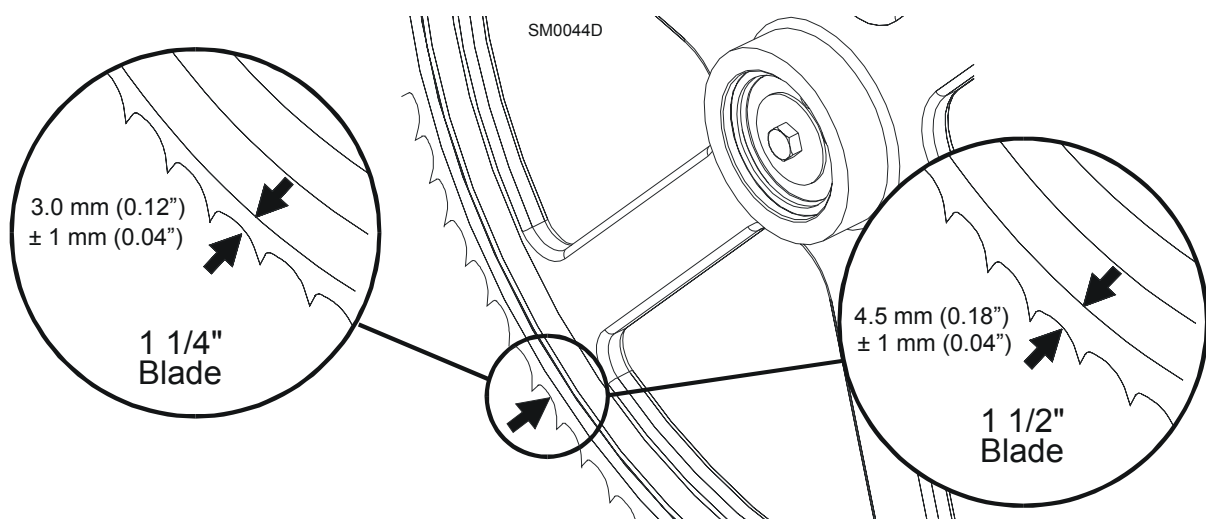

FIG. 3-3

4. Use the cant adjustment bolt to adjust where the blade travels on the blade wheels.

See Figure 3-4.

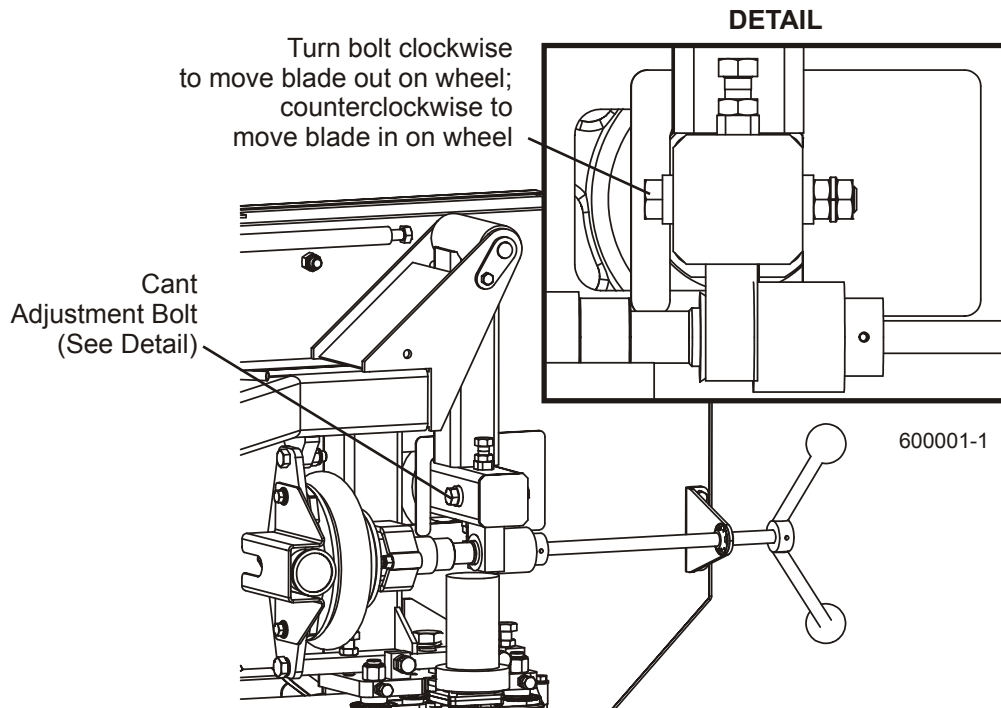

FIG. 3-4

To move the blade out on the blade wheel, turn the cant adjustment bolt clockwise. To move the blade in on the blade wheel, turn the bolt counterclockwise.

NOTE: Slight adjustments of the side bolts on the outer blade wheel are usually all that is necessary to track the blade properly. See Section 8.1.3 for complete blade wheel alignment instructions.

5. Adjust the blade tension if necessary to compensate for any changes that may have occurred while adjusting the cant control.
6. Spin the blade wheel by hand.
7. Check again the position of the blade on the blade wheels.
8. Repeat Steps 4 - 7 as necessary until the blade tracks on the blade wheels properly.
9. Turn the key switch to the #0 position.
10. Be sure to close the blade housing and pulley covers when the adjustment is complete.

3

SETUP

Tracking The Blade



DANGER! Make sure all guards and covers are in place and secured before operating or towing the sawmill. Failure to do so may result in serious injury. Be sure the blade housing and pulley covers are closed (i.e., the safety switches located on them are engaged).



IMPORTANT! After aligning the blade on the wheels, always double-check the blade guide spacing and location. (See Section 8 for more information.)

3.6 Starting The Motor

See the appropriate manual supplied with your specific engine/motor configuration for starting and operating instructions.



DANGER! Make sure all guards and covers are in place and secured before operating or towing the sawmill. Failure to do so may result in serious injury. Be sure the blade housing and pulley covers are closed (i.e., the safety switches located on them are engaged).

DANGER! Always be sure that all persons are out of the path of the blade before starting the motor. Failure to do so will result in serious injury.



WARNING! Always wear eye, ear, respiration, safety clothing, and foot protection when operating the sawmill. Failure to do so may result in serious injury.

3.7 Initial Control Programming

After the sawmill is installed and ready to operate, the control should be programmed. Reprogramming will also be required if the control CPU or transducer sensor is replaced.

To enter the initial programming mode, push and hold the MANUAL button for about 3 seconds (the power supply should be turned on, i.e. the key switch should be in the “1” position). The SETTINGS menu will be displayed.

To exit the Settings menu, push and hold the Manual button for about 3 seconds again.

Using the top button on the right joystick, you can access the individual programmable parameters in the following sequence:

Kerf (blade kerf value) > Bump Up (height by which the saw head raises after each cut) > Max Head (upper saw head travel limit) > PF adjustment (power feed dial calibration).

To change their values, use the left joystick. Pushing this joystick forward (away from you) will decrease the value; pulling it back (toward you) will increase the value.

3.7.1 Kerf Value

The kerf value setting can range from 0 to 10 mm. For standard Wood-Mizer blades, the kerf value should be set to 2 - 3 mm. If it is set to 0 mm, the blade kerf size will not be automatically added to the board thickness setting to compensate for the thickness of the blade. Example: If you are using a 2-mm-thick blade and set the board thickness to 25 mm (the kerf is set to 0), you will get a 23-mm-thick board (25mm - 2mm = 23 mm).

3.7.2 Bump Up Height

The Bump Up parameter (height by which the saw head will raise after each cut) can be set to a minimum of 3 mm and a maximum of 50 mm. Choose its value experimentally so that “trouble-free” board removal is ensured. If the Bump Up setting is too high, the board return fingers will not catch the board to drag it off when the saw head is being returned. If it is too low, the board return fingers will catch both the board and the log, which can result in damage to the board return mechanism or to the saw head.

Desired Bump Up values are usually in the range of 17 to 20 mm.

See Figure 3-5.

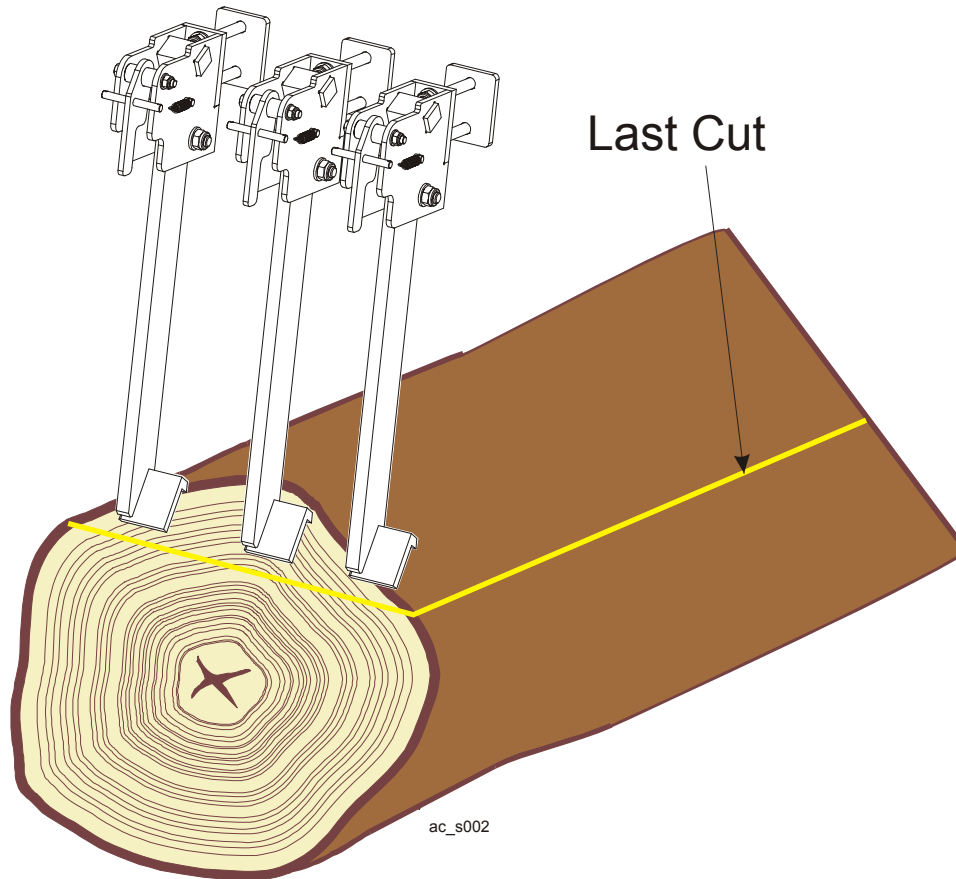

FIG. 3-5

3.7.2 Max Head H (upper saw head travel limit)

The Max Head H (upper saw head travel limit) is programmable (from 100mm to 885mm, the maximum height allowed by the length of the sawmill mast). This option is useful when the area where the sawmill is installed does not have enough height clearance to allow the saw head to travel to the top of the mast (to the height of 885 mm). In that case the upper head travel limit can be set to a lower height to ensure smooth sawmill operation.

3.7.3 PF adjustment (power feed dial calibration)

Calibration of the power feed dial is to set its range of operation, i.e. points of maximum and minimum saw head speeds (how many degrees the dial has to be rotated through to increase the saw head speed from the minimum to the maximum and vice versa). This setting determines sensitivity of the dial.

3

SETUP

PF adjustment (power feed dial calibration)

To calibrate the power feed dial, press the top button on the left joystick when „PF Adjustment” has appeared on the display. „PF Min” message should be displayed. Turn the power feed dial to a point where you want the saw head speed to be 0 (for this position of the dial the head speed will be 0). Then push the top button on the left joystick again. The display should now read „PF Max”. Place the dial at a point where you want the head speed to be maximum and press the top button on the left joystick. If the programmed range of dial operation is proper, „PF Set OK” will show on the display (the dial has been calibrated correctly). This means the calibration is complete. If „PF Min/Max Error” (calibration error) message is displayed, the programmed range of operation is too small (the minimum speed value is too close to the maximum one) and the calibration procedure has to be repeated. The range of dial operation is usually too small if the angle of dial rotation is lower than 60 degrees.

SECTION 4 OPERATION

4.1 Control Overview

The LT70 Remote control was designed to allow the operator to control the sawing operation with minimal effort and movement.

See Figure 4-1. The control includes several sets of buttons for controlling how the sawmill is programmed to cut a log. A description of each control component is provided below.

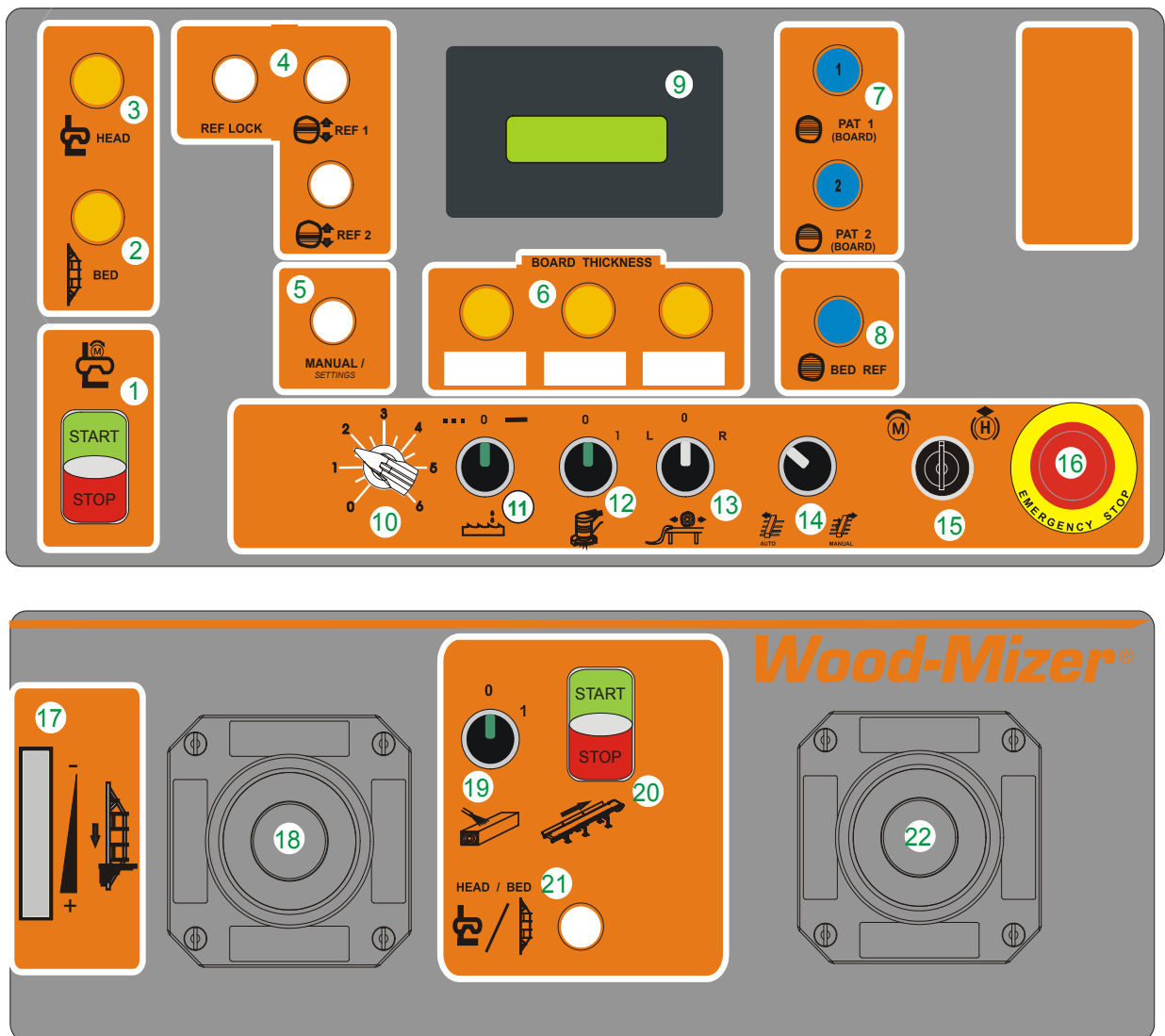



FIG. 4-1

1. START/STOP button – starts/turns off the blade motor.
2. BED light – When lit, indicates that the joystick controls are in BED mode. The joysticks can be used for log handling functions.
3. HEAD – When lit, the joystick controls are in HEAD mode. The joysticks can be used to operate saw head functions.
4. A group of buttons used when sawing in REF mode.
5. MANUAL/SETTINGS button - Push to enter MANUAL mode. **NOTE: When entering the Manual mode, board thickness values stored under PAT and REF buttons are cleared.** When you push and hold this button for about 3 seconds, you will go to the initial programming mode ([Patrz Rozdział 3.7](#)).
6. BOARD THICKNESS buttons - Three programmable buttons the operator can use to automatically drop the blade a pre-determined distance. A dry-erase marker can be used to temporarily label the area below each button with its value.
7. A group of buttons used when sawing in PATTERN mode.
8. BED REF button - When activated, the operator can automatically make cuts of identical thickness that are calculated from the sawmill bed.
9. Display - During the sawing operation, the display shows the current blade height location and the board thickness values currently being used. The display also displays error messages or values of certain features when the control is being programmed.
10. Lube Dial - Used to set the rate of lubricant flow in PULSE mode.
11. Lube Control Switch - Used to switch between PULSE and CONTINUOUS modes of the blade lubrication system.
12. Debarker Switch.
13. Infeed Deck Chain Switch (optional sawmill equipment) - engages/disengages the log infeed deck chain.
14. Transfer Deck Switch (the transfer deck can work in MANUAL or AUTOMATIC mode). It is available as optional sawmill equipment.
15. Key Switch - Turn the key to  position to power all electrical components. Place it in  position to release the motor brake.

- 16.** Emergency Stop button.
- 17.** Feed Rate Dial.
- 18.** Left joystick.
- 19.** Sawdust Blow-Off Switch - used to turn on/off the air blow-off which removes sawdust from the wood being cut while the saw head is moving in reverse.
- 20.** Incline Conveyor Belt Switch.
- 21.** Hed/Bed button - lets the operator toggle between HEAD and BED mode. The active mode is indicated by the lights described in items 2 and 3 above.
- 22.** Right joystick.

4.2 Controlling The Sawmill

LT70AC Remote sawmills are operated with the controls located on the front panel of the control box. Most of the sawmill head and bed functions are performed with two joysticks (left and right). The joysticks can work in two control modes:

- Head Mode
- Bed Mode.

In HEAD mode the joysticks control the following head functions: saw head up/down operation and forward/reverse movement, blade guide arm in/out movement and Auto Bump-Up function. In sawmills equipped with the debarker option, the right joystick can also be used to move the debarker in or out.

In BED mode the joysticks can be used for log handling functions such as: log loading, turning, clamping and levelling. Also, optional log handling equipment (e.g. log infeed deck option) is operated in this control mode.

4.2.1 Performing Log Handling Functions



To perform any of the log handling functions, first check if the yellow BED light is lit. If this light is on, the BED mode is active and you can operate all log handling functions. If it is

off, push the white HEAD/BED button. 

The use of the joysticks for performing the bed functions can be divided into three groups:

- Neither of the top buttons on the joysticks (neither on the left joystick nor on the right one) is pressed (**group No. 1**).
- Either of the joystick top buttons (left or right) has to be pressed and held (**group No. 2**).
- Both joystick top buttons have to be pressed and held (**group No 3**).

See **Figure 4-2. Group No. 1** of the log handling functions (neither of the joystick top buttons has to be pressed).

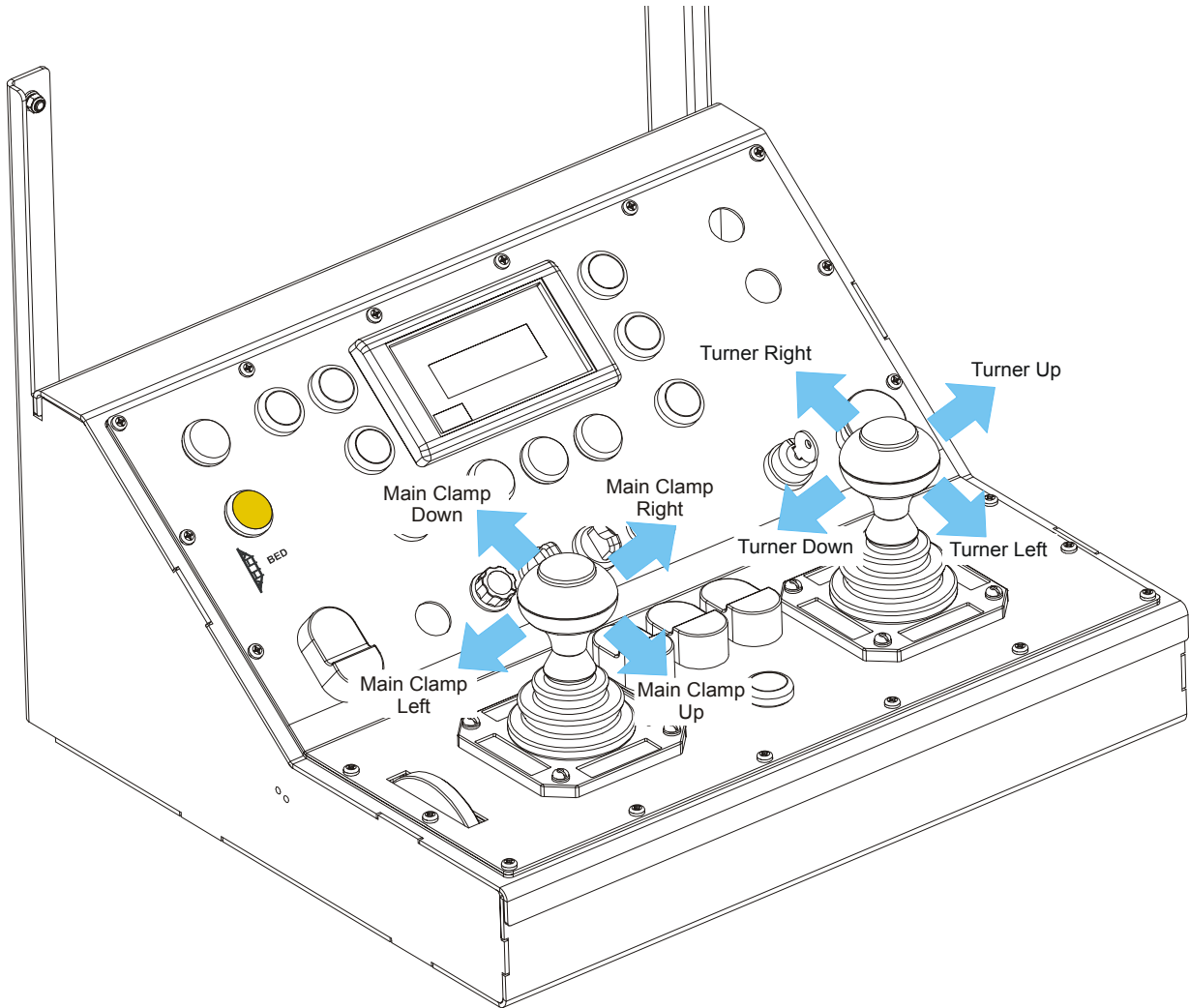

FIG. 4-2

4 Operation

Performing Log Handling Functions

See Figure 4-3. Group No. 2 of the log handling functions (either of the joystick top buttons has to be pressed and held).

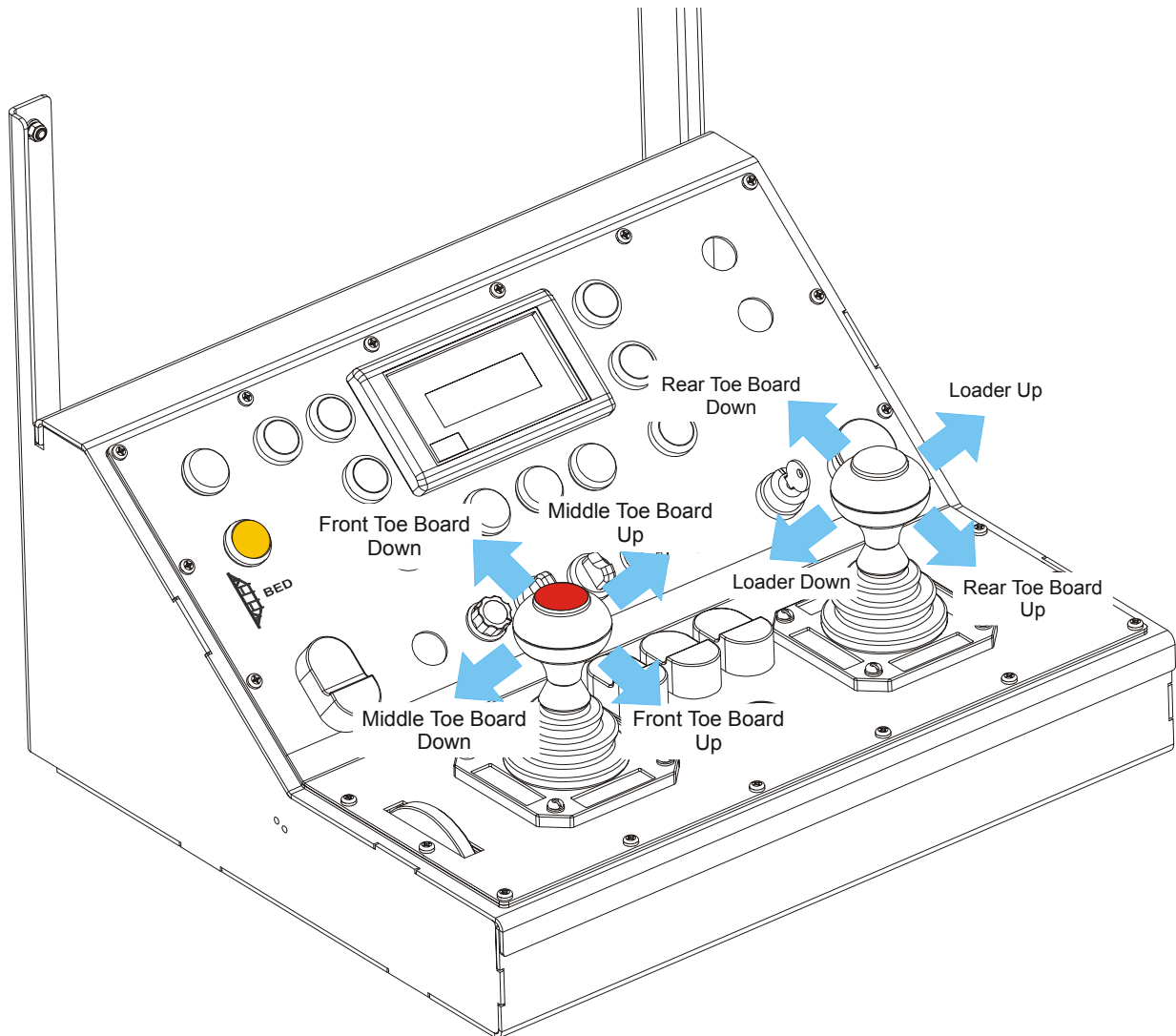

FIG. 4-3

See Figure 4-4. Group No. 3 of the log handling functions (both joystick top buttons have to be pressed and held).

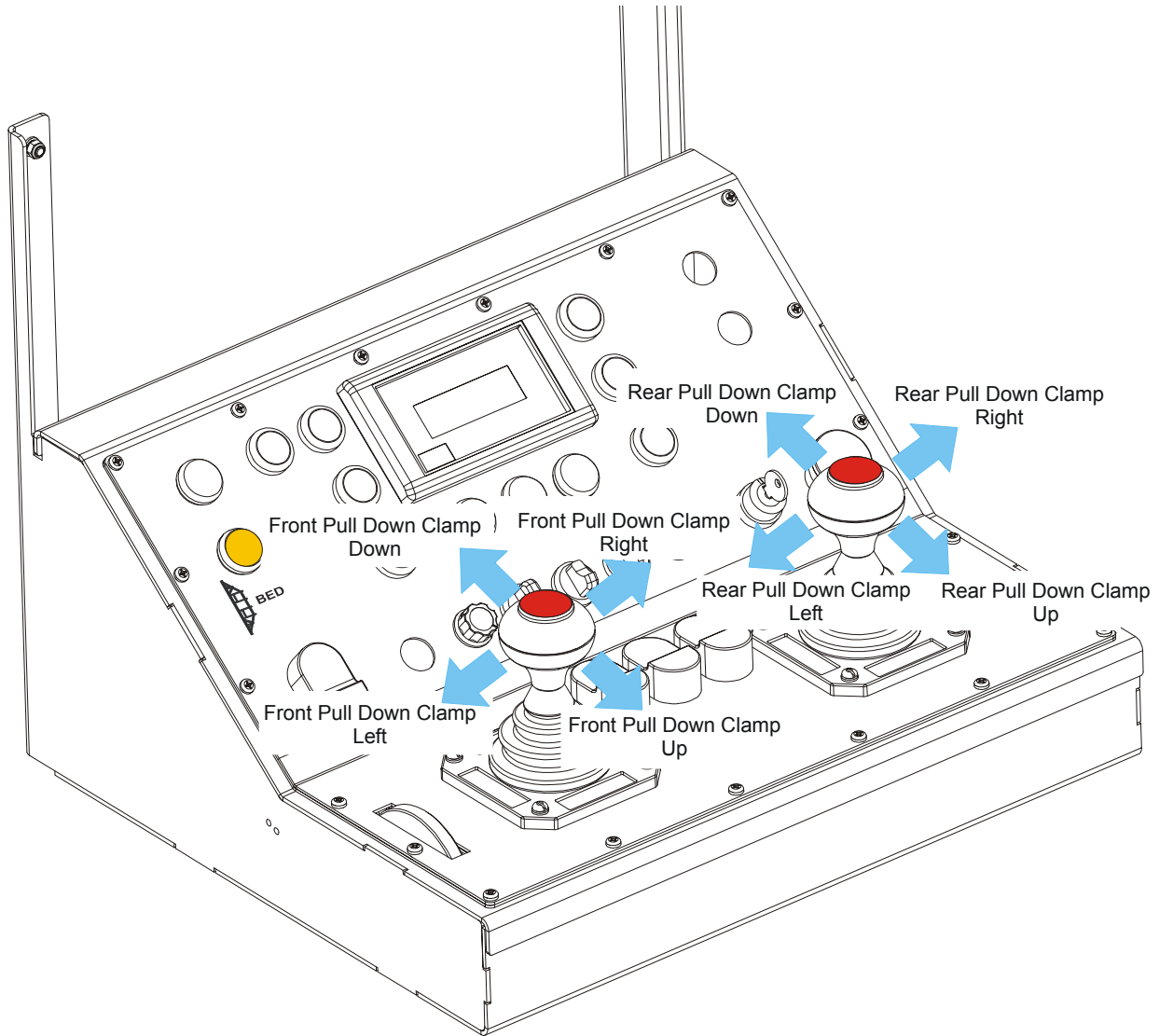

FIG. 4-4



The hydraulic pump motor automatically turns off 5 seconds after releasing the joysticks or immediately after switching to HEAD mode (pressing the HEAD/BED button).



4 Operation

Performing Head Functions

4.2.5 Performing Head Functions

 To perform any of the head functions, first check if the yellow HEAD light is lit. If this light is on, the joystick controls are in HEAD mode and you can operate all saw head functions. If the Head light is off, push the white HEAD/BED mode.  

See Figure 4-6. The figure below shows how individual head functions are performed with the joysticks.

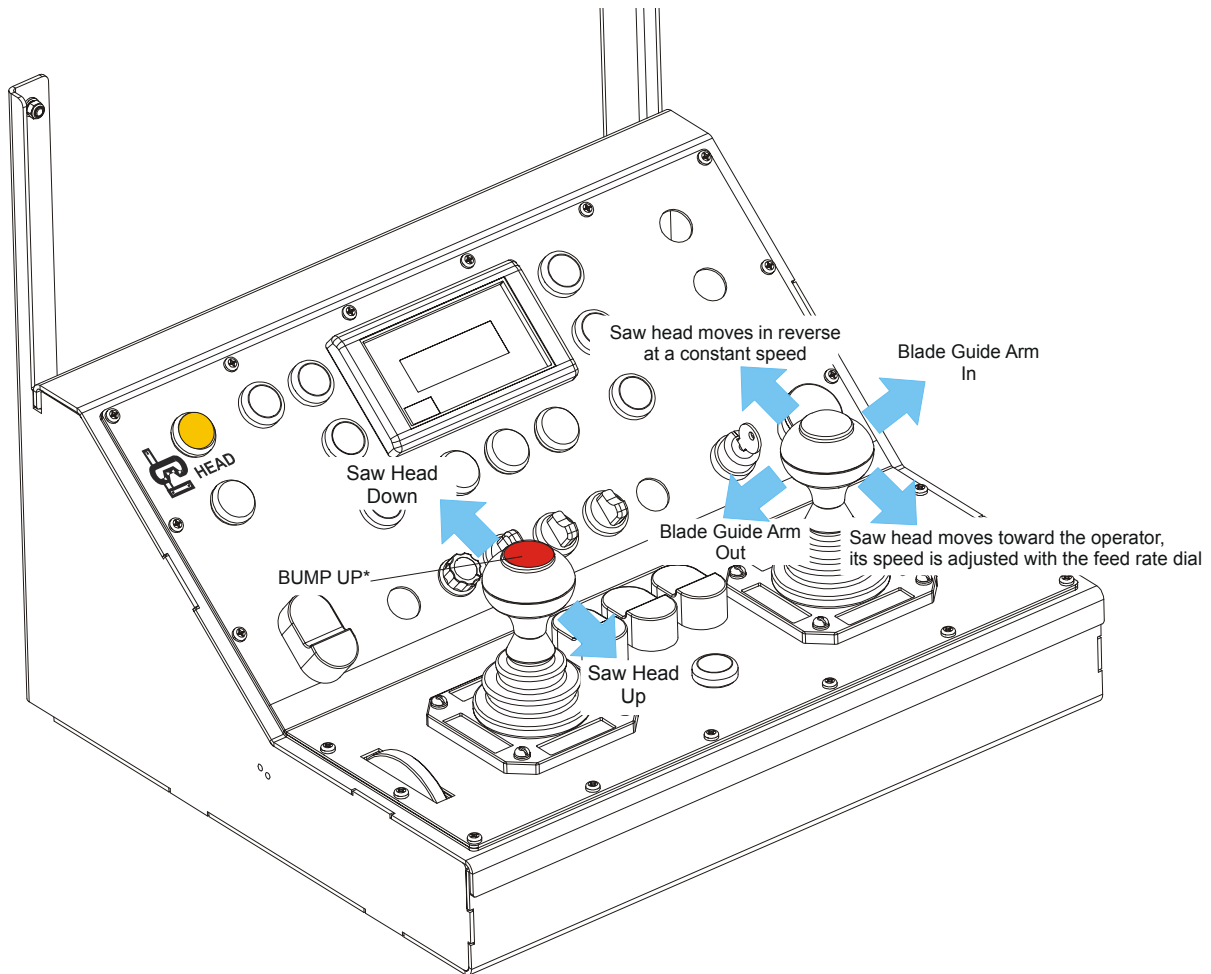

* Saw head raises automatically to a height allowing to drag off the board

FIG. 4-6

See Figure 4-7. Using the right joystick, you can also move the debarker (optional sawmill equipment) against or away from the log. To move the debarker in or out, press and hold the top button on this joystick and then push the joystick as shown below.

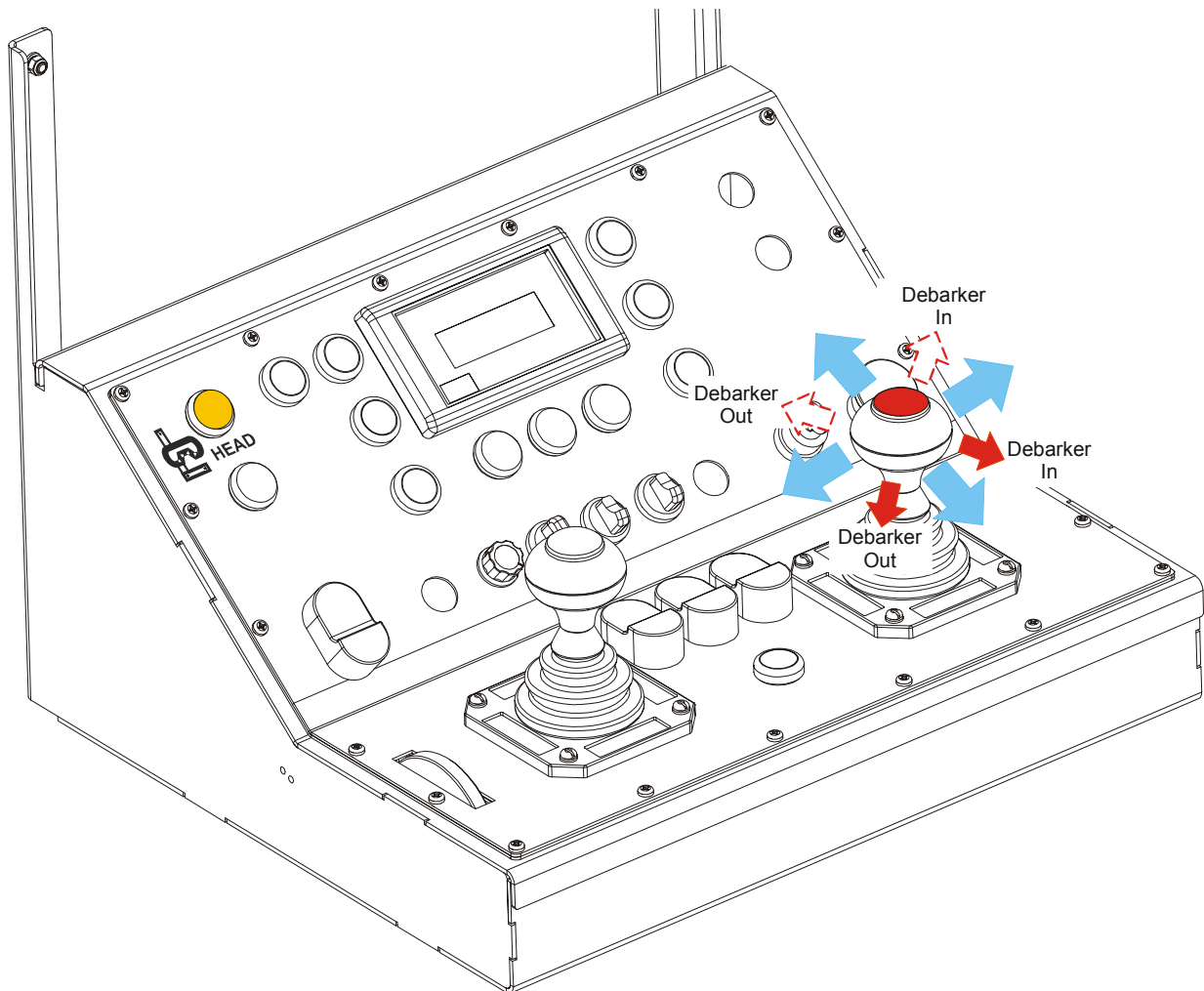

FIG. 4-7

NOTE:

Once the saw head passes the front or rear limit switch on the bed frame, it immediately stops. To move the saw head against the front or rear rubber stop, pull the right joystick toward you or push it away from you and, holding the joystick in this position, press and hold its top button. The saw head will approach the rubber stop at a low speed. **This is especially essential when sawing full-length logs.**

4.2.8 Up/Down Operation

In LT70AC Remote sawmills the upward/downward movement of the saw head can be controlled manually (MANUAL mode) or automatically (REF/PAT/BED REF modes).

In MANUAL mode the operator must position the saw head for the first cut by pushing or pulling **and holding** the left joystick. The joystick controls move the saw head up or down until the joystick is released.

Manual Control

1. To activate MANUAL mode (manual control), push the while MANUAL button. The button will illuminate.



MANUAL
SETTINGS

2. To move the saw head up or down to any height, push appropriately (toward you or away from you) and hold the left joystick.

Automatic Control

In AUTOMATIC control mode the saw head is **quickly** lowered or raised to the next cutting positions. This considerably reduces the time needed to prepare the sawmill for cutting the next board or cant.

There are two sawing methods that can be used to automatically cut preset sizes on the LT70AC Remote sawmill:

REF MODE

- The computer references a temporary position of the blade and automatically moves the blade either up or down from that position the distance determined by the selected BOARD THICKNESS dimension. This method is best used when sawing a log into a cant and thickness of the last board is of no importance. When applying this method of automatic sawing, a group of white buttons at the left of the display (REF 1, REF 2 and REF LOCK) is used.

PATTERN AND BED REF MODES

- The computer calculates all cuts for the active board thickness **from the bed of the sawmill**. The blue PAT 1 and PAT 2 buttons, located at the right of the display, activate a function allowing the operator to preset thickness of the board (cant) that will remain on the sawmill bed after the last cut. This board can be of a thickness different from other boards'. If the operator wants to get identically-thick boards

(i.e. each board being cut, up to the last one, is of the same thickness), he can use BED REF function (the blue BED REF button on the control panel).

4.2.9 Programming board and cant thicknesses (possible only when REF1, REF2, PAT1, PAT2 or BED REF is enabled)

The operator can program several thicknesses of boards and cants that will be used most frequently when sawing in automatic mode (REF1, REF2, PAT1, PAT2, BED REF functions).

See Figure 4-10. The control includes five buttons that can be used to program board thicknesses. These buttons are: three yellow BOARD THICKNESS buttons, located under the display, as well as the blue PAT 1 and PAT 2 buttons, located at the right of the display. When you are using PAT1 or PAT 2 function, the selected PAT1 or PAT2 button indicates thickness of the lowest dimension (cant) the saw will cut. Board thicknesses that will be used until you get this dimension can be programmed under Board Thickness buttons only. After pushing the Board Thickness button that stores a desired board thickness, the light located under this button comes on. When REF1, REF2 or REF LOCK function is on and you select either of PAT buttons, with a pre-programmed board thickness, this button will illuminate. The active board thickness is always shown on the display. To switch between the pre-programmed board thicknesses, use the **top button on the right joystick**.

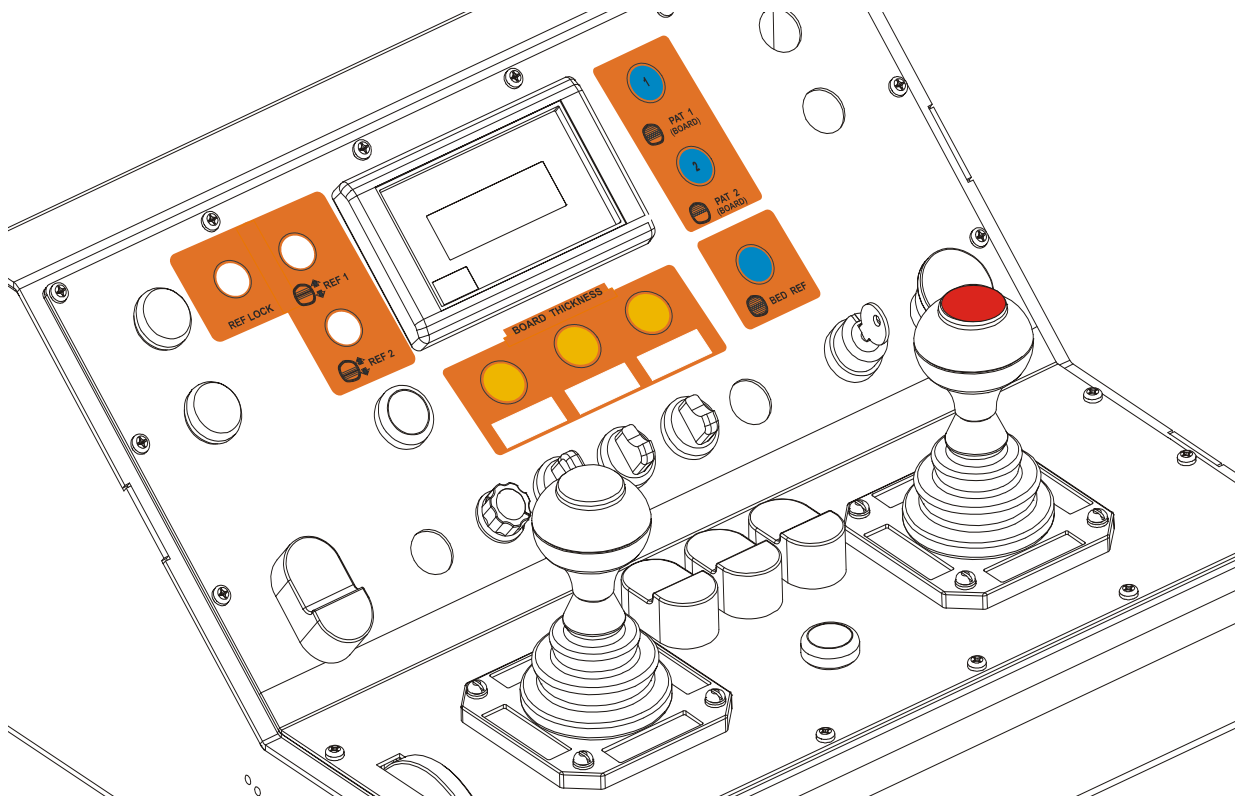

FIG. 4-10

4

Operation

Programming board and cant thicknesses (possible only when REF1, REF2, PAT1, PAT2 or

When you first turn on the machine after its installation, the following board thicknesses are in the computer memory:

- Board 1 - 25mm
- Board 2 - 35mm
- Board 3 - 50mm
- Board 4 - 75mm
- Board 5 - 80mm
- Cant 1 (Pat) - 50mm
- Cant 2 (Pat) - 100mm.

Each of these values can be changed at any time. To do this:

1. Push and hold the top button on the right joystick for about 3 seconds.
2. You will enter the *Setup* function (Edit Mode).
3. Push the top button on the right joystick as many times as necessary to access the board thickness (storage cell) you want to change. *When PAT1 or PAT2 is active, you can use this button also to switch between Cant thicknesses in the following sequence: Board1, Board2, Board3, Cant1, Cant2.*
4. Pulling the left joystick toward you or pushing it away from you, you can increase or decrease the board thickness setting in 1mm increments. When you hold this joystick for about 2 seconds after pushing it in the appropriate direction, the board thickness value will be increasing or decreasing continuously (fast).
5. Push and hold the top-right joystick button again for about 3 seconds to exit the *Setup* function (Edit Mode). From now on the modified board thickness value is stored in the computer memory.

4.2.11 REF functions (temporary referencing the blade location)

REF1 and REF2 functions, as mentioned earlier in this section, are typically used when sawing a log down to a cant, i.e., until all four sides of the log are flat.



With a new log loaded and clamped in position on the sawmill bed, press the white HEAD/BED button to activate HEAD mode. The yellow HEAD light will come on. The joysticks can now be used to control all saw head functions.

Then push the white MANUAL button to turn Manual mode on (manual saw head control). The button will illuminate.

Using the left joystick, position the saw head at the height where you want to make the first cut on the first side of the log.

Instead of the MANUAL button, you can press REF1 or REF2 button (**REF LOCK disabled**) to position the blade for the first cut on a given side of the log.

NOTE: Do not use the MANUAL button after making cuts on the first two sides of the log; this will clear all stored references.

After the blade has been positioned for the first cut, press REF1 button (if it has not been done earlier), **REF LOCK button and REF1 button again. The REF1 button will start flashing (NEXT CUT ON).** Once the REF LOCK button is pressed, the current blade position is stored in the computer memory. The computer will reference this position when raising or lowering the saw head for the next cut.

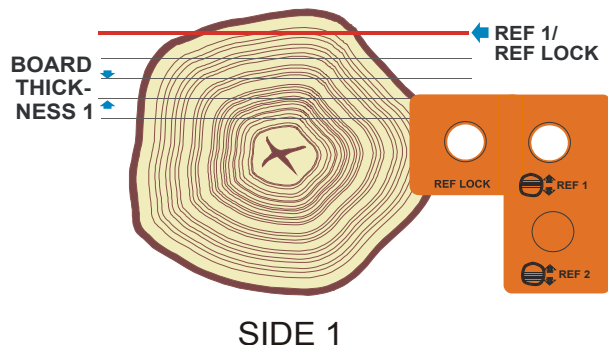

Press the START/STOP button to turn the blade motor on. Then make the first cut. To do this, pull the right joystick toward you. While making the cut, adjust the blade speed by turning the feed rate dial located at the left of the control box.

As soon as the blade exits the log and the board return fingers drop down at the end of the log, press the top button on the left joystick (BUMP UP button). This will raise the saw head to a height allowing to drag the board/slab off when the head is being returned. If you want the saw head to be raised higher, press the top-left joystick button two or more times. The BUMP UP height (a distance by which the saw head can be automatically raised after each cut) can be adjusted in the Settings menu (initial programming mode) ([Patrz Rozdział 3.7.2](#)).

NOTE: If the slab is too small to drag back, pull the left joystick toward you to raise the

4

Operation

REF functions (temporary referencing the blade location)

blade over the slab. Once the blade is above the slab, release the joystick then pull it back again and release. (The display should read “ABORT!!! ABORT!!!”). This will abort the control before it reaches the next programmed target, preventing it from replacing the stored position of the blade during the last cut.

Pushing the right joystick away from you, return the saw head. The board will be dragged off the log and thrown onto the incline conveyor (if the machine is equipped with this sawmill option). Before you make the next cut, select the board thickness dimension. Use the top-right joystick button to search for the desired board thickness. If you do not find the desired board thickness dimension, reprogram any of the stored board thicknesses ([Patrz Rozdział 4.2.9](#)).

After selecting the board thickness for the next cut, push the left joystick momentarily away from you (you do not need to hold the joystick until the head reaches the desired position). The saw head will automatically lower for the next cut.

Make cuts as desired until you are ready to turn the log.

After making the desired number of cuts on the first side of the log, move the saw head to the end of the bed frame*. Then press the HEAD/BED button to place the joystick controls in BED mode. Using the joysticks, turn the log and position it on the bed rails ([Patrz Rozdział 4.2.1](#)). When the log has been positioned on the bed and is ready for the first cut, activate the Head mode again with the HEAD/BED button (the HEAD light will come on again). Once you press this button, REF1 and REF LOCK functions will turn on again (since they were active when HEAD mode was switched to BED mode). To position “manually” the saw head for the first cut on the second side of the log, you have to disable the REF LOCK function. To do this, press the REF LOCK button. The REF LOCK button light will go out. (The REF1 function is still turned on; the REF1 button is still illuminating). Now, using the left joystick, you can position the blade at the height where you want to make the first cut on the second side of the log. Please remember to activate the REF LOCK function again after positioning the blade for the first cut. This will store the current blade position in the computer memory and the next cut will be calculated from this position, determined by the selected board thickness dimension. To make cuts on the second side of the log, repeat the steps used to cut the first side of the log, until you are ready to turn the log.

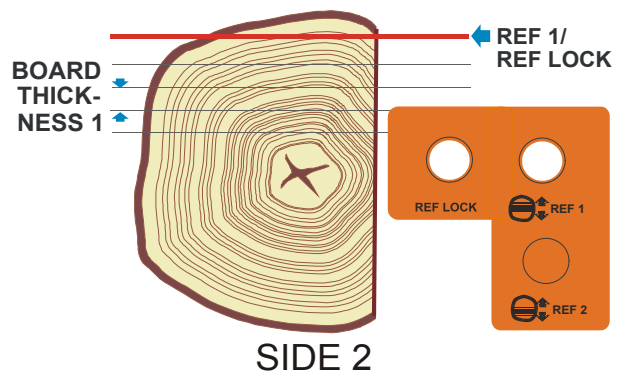

*The end of the bed frame is the frame's part which is the furthest from the control box.

Using the procedure described above, make cuts on the third side of the log as desired.

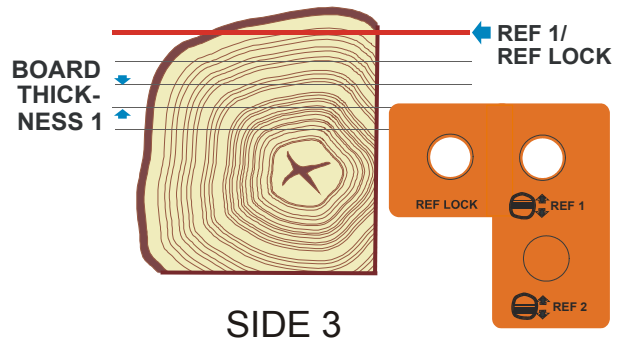

When the log is ready for making cuts on its fourth side, activate HEAD mode again (the yellow HEAD light as well as the lights of REF1 and REF LOCK buttons will come on) and then press the REF2 button. (Pushing the REF2 button will disable the REF LOCK function.) Using the right joystick, position the blade for the first cut on the fourth side of the log. Then push the REF LOCK button and again the REF2 button (the REF2 button light will start flashing).

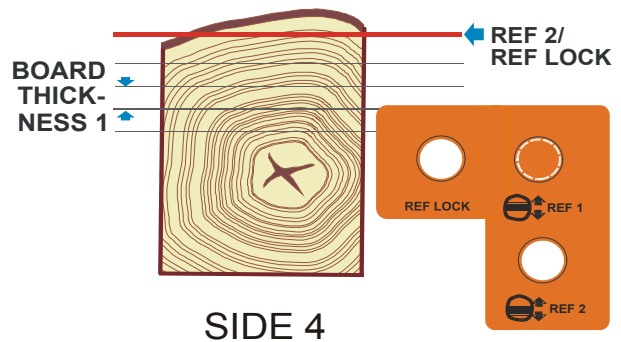

Once you press these buttons, the current blade height (at which the first cut will be made) is stored in the computer memory. The computer remembers also the height of the last cut made on the previous (third) side of the log (this information is stored under the REF1 button). This allows automatic positioning of the blade for the first cut when the log is turned again (for the fourth time). The operator will not have to “manually” (i.e. in Manual mode) set the blade at the first cutting height.

Make cuts on the fourth side of the log until you reach the desired cant. Use the same procedure as for cutting on the previous sides (except that, REF2 should be used instead of REF1).

After the log has been squared, turn the cant and position it on the sawmill bed. Then activate HEAD mode (the yellow HEAD light will come on) and push the REF1 button twice (the button will start flashing). The REF LOCK function will turn on automatically (the REF LOCK button will illuminate). The display will show (in the fourth line) the blade height at which the last cut on the third side of the log was made, i.e. the last cutting height in REF1. When you use the left joystick appropriately, the saw head will automatically position for the next desired cut referenced from the last cut made in REF1 (**NEXT CUT function**). If you push the left joystick forward and hold it in this position, the saw head will be lowering until the joystick is released. If you release the left joystick when the blade is below the desired cutting height, the saw head will automatically raise until this height is reached.

4

Operation

REF functions (temporary referencing the blade location)

NOTE:

The fact that the saw head stops and starts moving in a reverse direction after releasing the joystick, with the NEXT CUT function on (REF1 or REF2 light is flashing, REF LOCK light is illuminating), is often considered a fault by operators. For example, if, having pushed the joystick forward and having held it in that position, you release the joystick, the saw head will stop and then start raising. It is not a fault as the saw head, with NEXT CUT on, is always moved to the next cutting height regardless of its current position.

See Figure 4-12. If you push the left joystick away from you, with the blade being above the next cutting height, the saw head will automatically **lower** for the next cut the distance determined by the selected board thickness dimension and calculated from the last cutting position in REF1. Pulling the left joystick back, i.e. toward you, with the blade being below the next cutting height, will **raise** the saw head to this height.

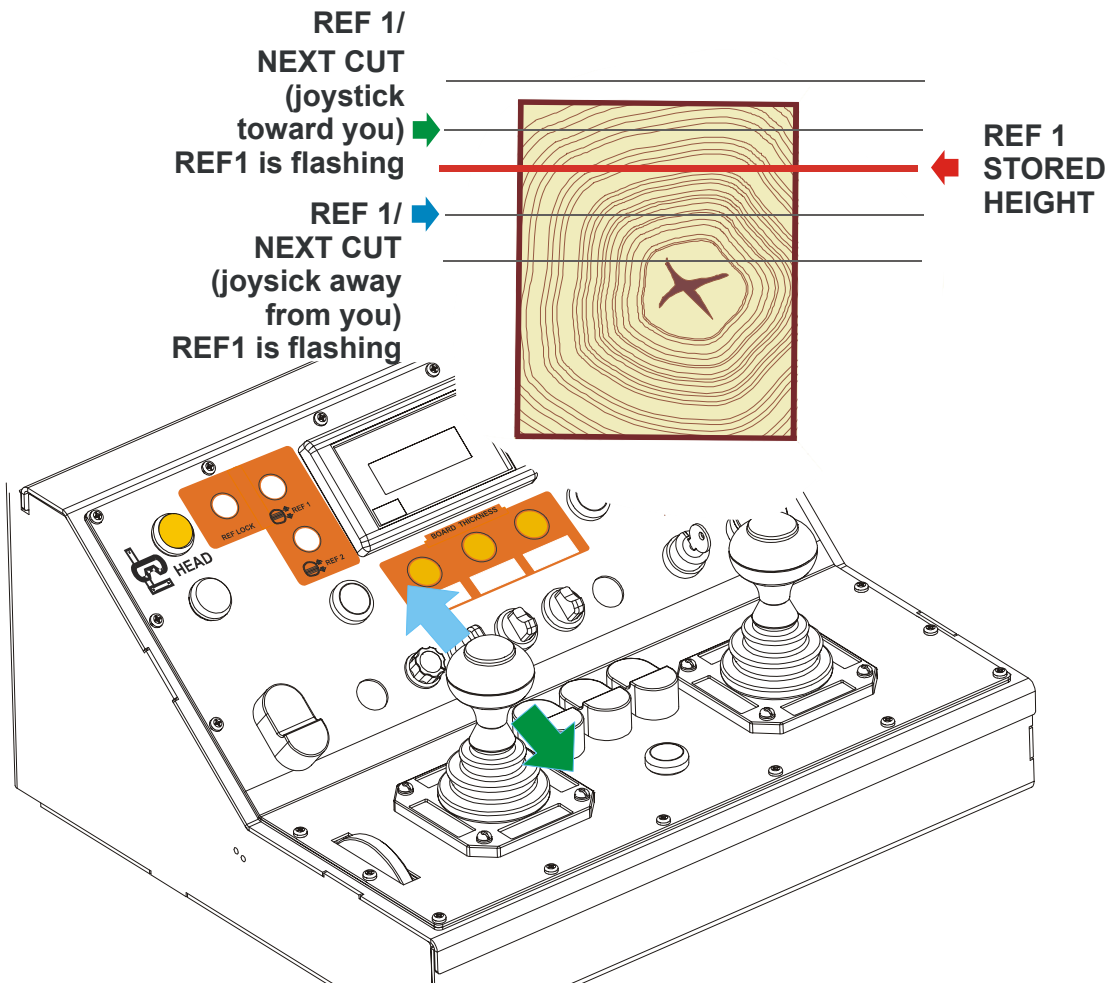

FIG. 4-12

To make the next cut, first press the REF1 button twice (the REF1 button light will start flashing). The REF LOCK function will turn on automatically (the REF LOCK button will

illuminate). To make the cut, use the left joystick as described above.

After turning the cant again and levelling it on the sawmill bed, activate HEAD mode again and press the **REF2** button twice (the button light will start flashing). The REF LOCK function will turn on automatically (the REF LOCK button will illuminate). When you push the left joystick appropriately, the saw head will automatically position for the next cut referenced from the last cut made in REF2 (determined by the selected board thickness).

When REF LOCK is enabled (REF1 or REF2 is activated), two functions can actually be performed. One of them is the NEXT CUT function explained above (it is active when the REF1 or the REF2 button is flashing). The other function can be enabled by pushing the flashing REF1 or REF2 button again, or by pushing the REF LOCK button with the NEXT CUT function activated. When it is active, the lights of REF LOCK and REF1 or REF2 buttons **are on steady state**. See the example below for an explanation of how this function works.

4

Operation

REF functions (temporary referencing the blade location)

See Figure 4-13. Example: The saw head is at the height of 300 mm, the REF1 and REF LOCK functions are turned on (REF1 and REF LOCK lights are on steady state, the display reads: „Ref 1 Lock 300mm”). The selected board thickness is 50 mm (the display reads: „Board 1 50mm”).

Push the left joystick away from you and hold it. As long as the left joystick is engaged, the saw head will be moving down. **When you release the joystick, the saw head will move to the nearest (below the height at which the joystick was released) multiple**

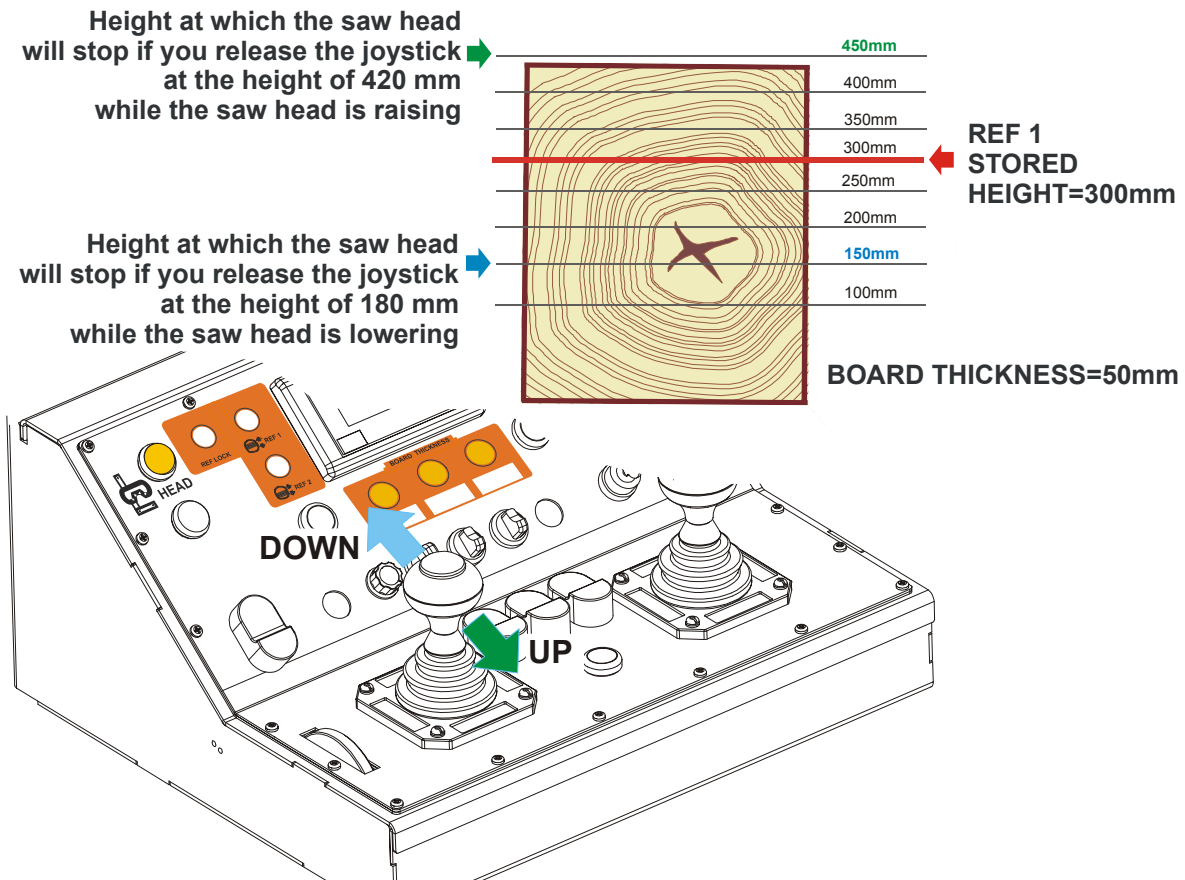

FIG. 4-13

of the selected board thickness calculated from the last cutting position in REF1. In this example the left joystick was released when the saw head was at the height of 180 mm. Therefore, the saw head will stop at the height of 150 mm (to make the explanation clearer we assume that the blade kerf is 0). If you pull the left joystick toward you and hold it, the saw head will be moving up. When you, for example, release the joystick at the height of 420 mm, the saw head will raise to the height of 450 mm (as this is the nearest - above the height of 420 mm - multiple of 50 mm, calculated from the stored REF1 height).

4.2.14 PAT and BED REF (referencing the blade position from the bed surface)

The PAT and BED REF functions are typically used after the log has been squared, i.e., for cutting a cant. The PAT functions (PAT1 and PAT2) allow to program the lowest dimension the saw will cut (i.e. thickness of the board that will remain on the sawmill bed after the last cut). The operator can use one of these functions when this lowest dimension is to be different than thicknesses of the remaining boards (e.g. the bottom board is to be 40 mm thick, and the remaining boards 25 mm thick). The BED REF function allows to cut identically-thick boards.

Two sawing options can be performed when using PAT or BED REF function, as in the case of REF functions. Pushing PAT1, PAT2 or BED REF button once will activate the option of moving the saw head to a multiple of the selected board thickness dimension (the button light will be on steady state). When you press any of these buttons again, the NEXT CUT option (that is used most frequently) will be turned on (the button light will be flashing). See the description of REF functions above.

- **PAT1 and PAT 2 functions**

PAT1 and PAT2 functions work identically except that the bottom board (Cant) is of a different programmed thickness. For example, you can program 100-mm-thick bottom board under PAT1 and 200-mm-thick board under PAT2.

To enable PAT1/PAT2 function, push the blue PAT1/PAT2 button located at the right of the display. Pressing the PAT1/PAT2 button once (the button light is on steady state), activates the option of moving the saw head to a multiple of the selected board thickness dimension (see the description of this option in REF). If you press the PAT1/PAT2 button again (the button light is flashing), the NEXT CUT option will be turned on. When you push the left joystick momentarily toward you or away from you, the saw head will move to the nearest height from which the number of boards that will be cut from the cant, including the board that will remain on the bed, will be a whole number. After making the first cut (if the NEXT CUT function is turned on - PAT1/PAT2 button is flashing), the saw head will be raised or lowered the distance determined by the selected board thickness, until you get the programmed bottom board. The saw head may not lower below the programmed lowest dimension (thickness of the bottom board). See a SIMPLIFIED example of sawing a cant in PAT mode below.

4

Operation

PAT and BED REF (referencing the blade position from the bed surface)

See Figure 4-15. Example: In this example the blade kerf is 0. You are sawing 30-mm-thick boards from a 500-mm-thick (high) cant and want to finish with a 100-mm-thick cant. The saw head is at the height of 510mm.

First activate MANUAL mode (the MANUAL button will illuminate). Using the left joystick, position the saw head at the height where you want to make the first cut. In most cases this location will be close to the height of the cant that will be cut. In this example it is 510mm. Then activate PAT1 (or PAT2) function by pressing twice the PAT1 (or PAT2) button (the PAT1/PAT2 button is flashing; NEXT CUT is turned on). Push the left joystick away from you momentarily. The saw head will move to the height of 490mm as this is the nearest height from which you can get a whole number of 30 mm thick boards plus a 100-mm-thick cant. The first board will be 10mm thick. It is because it is not possible to cut only 30-mm-thick boards from a 500-mm-thick cant if you want to finish with a 100- mm-thick bottom board. The last possible cutting height in this example is 100 mm (since the preset bottom board thickness is 100 mm).

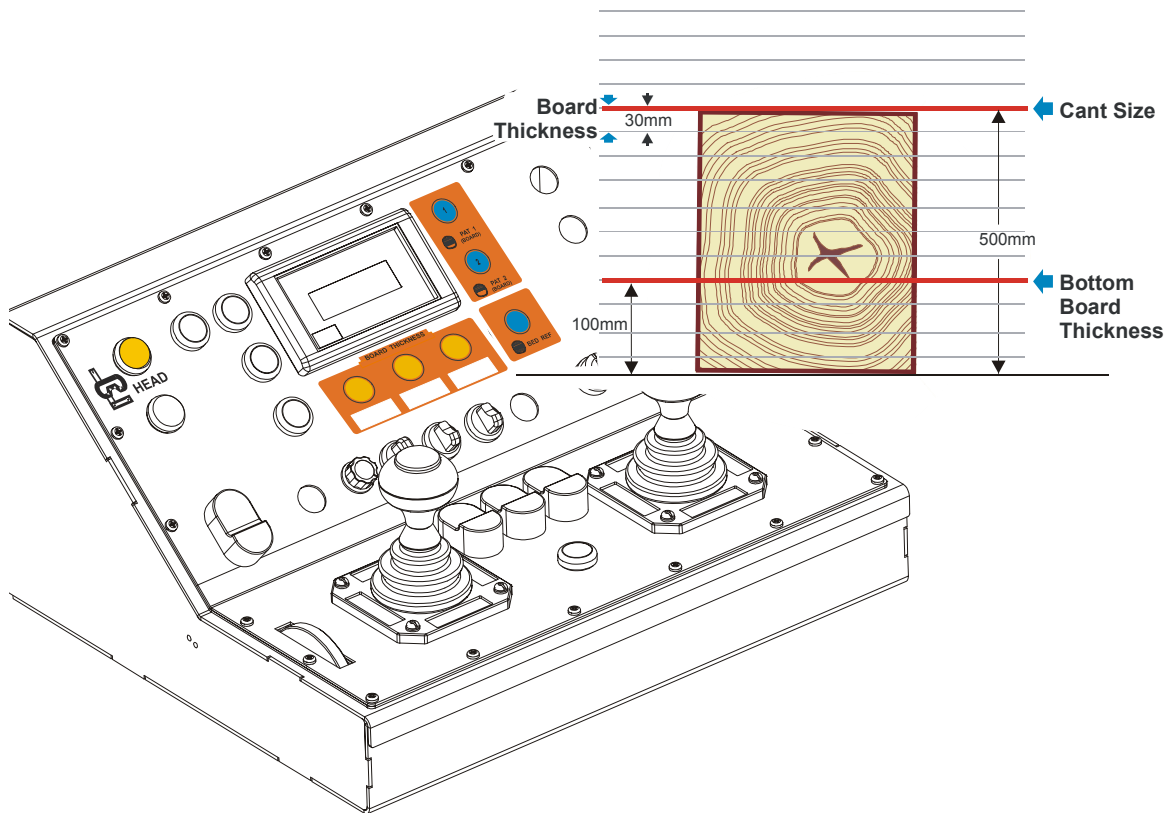
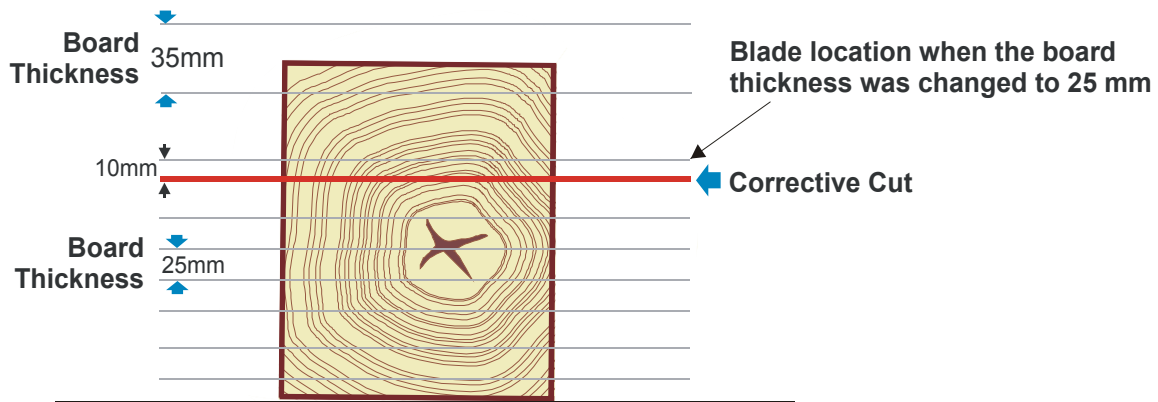

FIG. 4-15

NOTE!

If you change the board thickness dimension while using PAT1, PAT2 or BED REF button



(e.g. from 35 mm to 25 mm), it may be necessary to make a corrective cut. This means that the first board cut after changing this dimension will be of a different thickness (10 mm in this example). The next boards will be of the desired thickness (25 mm).

■ **BED REF**

The BED REF function works similarly to the PAT1 and PAT2 functions. The only difference is that all boards cut in BED REF are of the same thickness whereas in Pat1 and PAT2 the last board (i.e. the board remaining on the sawmill bed after the last cut) can be of thickness different from other boards'.

In BED REF mode you can use up to five pre-programmed board thicknesses (they are stored under the Board Thickness buttons as well as the PAT1 and PAT2 buttons). In PAT mode the PAT1 and PAT2 buttons store thicknesses of the lowest dimension that saw will cut. Only Board Thickness buttons can be used to program thicknesses of the boards that will be cut until you get this lowest dimension.

SECTION 5 MAINTENANCE

This section lists the maintenance procedures that need to be performed.

The Short Interval Maintenance Schedule lists procedures that need to be performed every 4, 8 or 24 hours. The Maintenance Log lists procedures that need to be performed every 50, 100, 200, or 1000 hours. Keep track of machine maintenance by filling in the machine hours and the date you perform each procedure.

 **This symbol** identifies the interval (hours of operation) at which each maintenance procedure should be performed.

Be sure to refer to option and engine manuals for other maintenance procedures.

5.1 Wear Life

Patrz tabela 5-1. This chart lists estimated life expectancy of common replacement parts if proper maintenance and operation procedures are followed. Due to the many variables which exist during sawmill operation, actual part life may vary significantly. This information is provided so that you may plan ahead in ordering replacement parts.

Part Description	Estimated Life
B57 Blade Wheel Belts	500 hours
Blade Guide Rollers	1000 hours
Drive Belt	1250 hours

TABLE 5-1

5.2 Blade Guides

1. Check the rollers for performance and wear every blade change. Make sure the rollers are clean and spinning freely. If not, rebuild them. Replace any rollers which have worn smooth or have become cone shaped.

EZ-Glide Guide Blocks

2. Inspect the blocks at every blade change for damage or wear. If the block housing is bent or damaged, replace the block assembly. Also, replace the block assemblies before the blocks are worn to a point the blade may contact the block housing.

As the blocks wear, the front inside corner will wear more than the body of the block. When the corner wears far enough, sawing performance will be affected even if the body of the block is adjusted properly to the blade. At this point, the block should be replaced. If you have access to the appropriate equipment, you can grind or mill the blocks to a new flat surface and reuse them. It is recommended you develop a routine schedule for replacing the blade guide blocks based on your sawing conditions and experience.

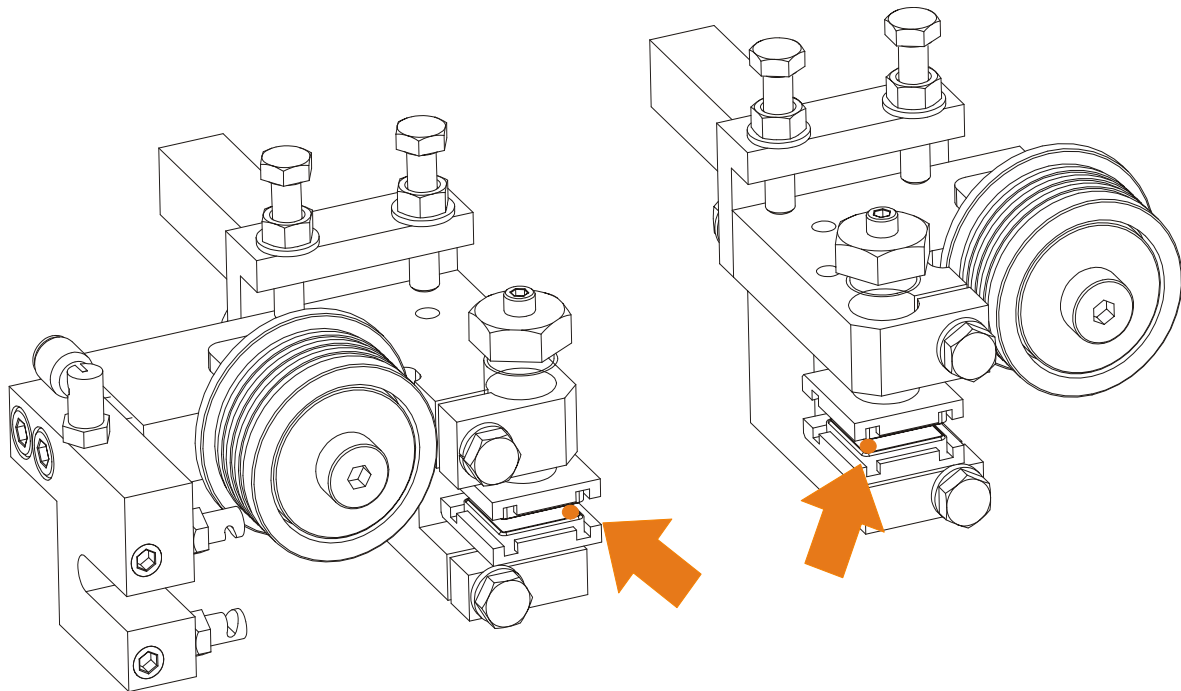

FIG. 5-0

3. Check the ceramic inserts are properly spaced from the bottom of the blade every 25 hours of operation. As the rollers wear, the gap between the blade and inserts will

25

5

Maintenance

EZ-Glide Guide Blocks

become larger. Use the provided shim or a feeler gauge to check the inserts are adjusted 0.2 - 0.25 mm from the blade.

See Figure 5-1. To adjust the disks up, loosen the bottom guide disk mounting bolt and clamp bolt. Use the provided adjustment tool to raise bottom disk. Retighten the bottom disk mounting bolt and clamp bolt.



IMPORTANT! The ceramic inserts should be parallel to the blade. Check the space between the insert and the blade at each side of the insert to insure it is parallel. Use the appropriate outer adjustment bolt to tilt the insert mounting plate so the insert is parallel to the blade.

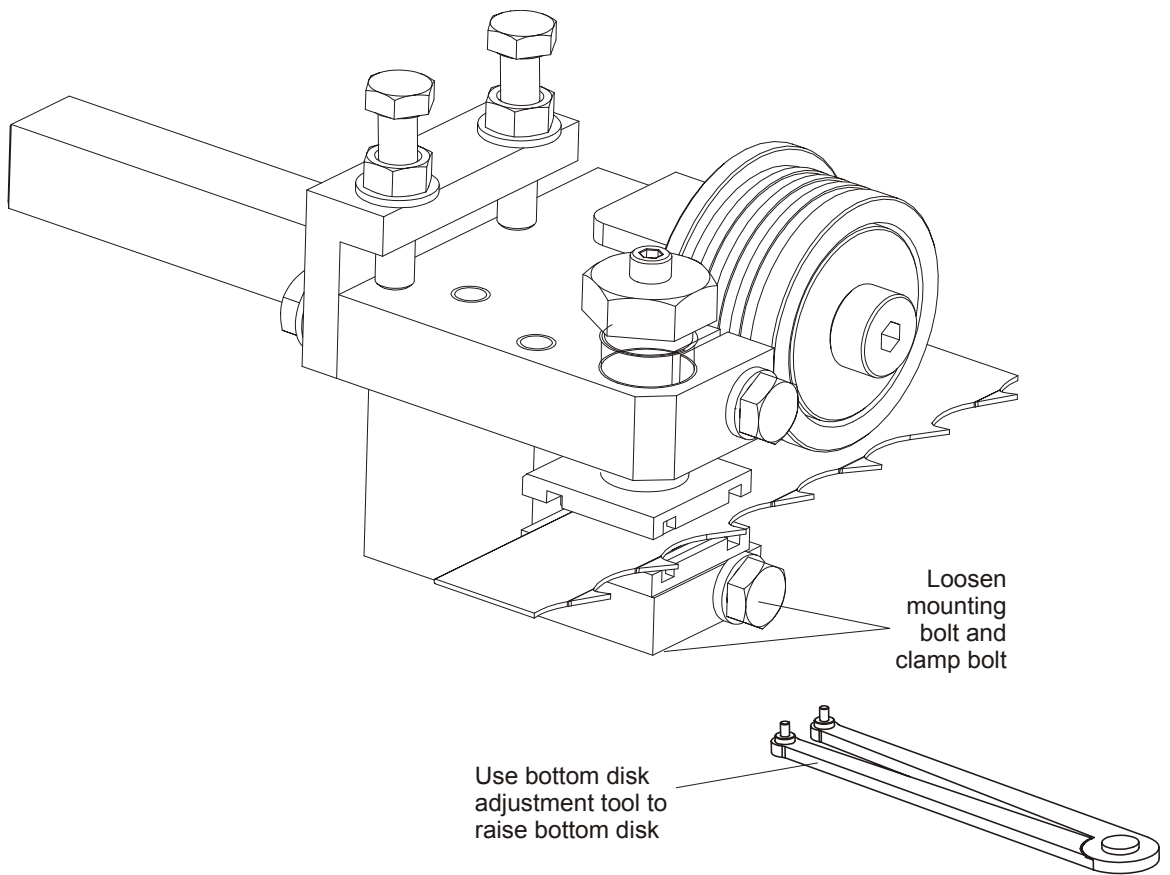

FIG. 5-1



Inspect the blade guide assemblies for proper alignment everytime you change the blade. See Section "Blade Guides", page 7-6 for blade guide adjustment instructions.



WARNING! Blade guide alignment is essential for optimal

cutting performance, blade life and safety. Failure to check and maintain proper blade guide alignment will result in stress cracks forming in the blade. These cracks will lead to premature blade breakage. If the blade breaks during operation and the blade has multiple stress cracks, the blade could shatter into several pieces and escape from the protective guards of the sawmill. Small blade pieces projected into the area around the sawmill creates a safety hazard for the operator and any bystanders surrounding the mill.



WARNING! DO NOT use blades with stress cracks. Blades with stress cracks can shatter causing bodily injury and/or machine damage.

Make sure the blade screw in the top center of the C-frame is 1/16" (1.5 mm) away from the blade. If not, loosen the nut and adjust the screw as necessary. Check the screw every blade change. Failing to maintain this adjustment will lead to early blade breakage.

See Figure 5-2.

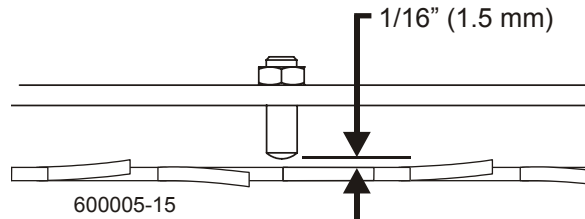

FIG. 5-2

5.3 Sawdust Removal

1. Remove the excess sawdust from the blade wheel housings and sawdust chute every blade change.
2. As required, remove sawdust buildup from the power feed belt housing. Turn the key to the OFF (#0) position and remove the key. Disassemble the power feed belt cover and remove sawdust buildup in and around the power feed belt and pulleys. Replace the power feed belt cover.

AR

5.4 Carriage Track, Wiper & Scrapers

Properly maintaining the sawmill carriage track is critical in preventing corrosion that can cause pitting and scaling on the rail surfaces. Pitted and scaled surfaces can, in turn, cause rough cuts or jerky power feed movement.

See Figure 5-3.

1. Clean track rails to remove any sawdust and sap buildup every eight hours of operation.

8

Use a light-grade sandpaper to sand off any rust or other adhering particles from the rails.



CAUTION! Keep track rails free of rust. Formation of rust on the track rail in the areas where the cam bearings roll can cause rapid deterioration of the track rail's surface.

Lubricate the rails by wiping them with Dexron III ATF transmission fluid, 10W30 motor oil, or 3-in-1 turbine oil. Oil lubrication will help protect the rails from corrosive elements such as acid rain and/or moisture from nearby bodies of saltwater (if applicable). This lubrication is essential to maintain the integrity of the track rails and track rollers and to achieve long service life.

2. Remove sawdust from the track roller housings and lubricate the felt track wiper every twenty-five hours of operation.

25

Remove the track roller housing covers and brush any sawdust buildup from the housings.

Clean and lubricate the felt track wiper. Unbolt the middle track cover, remove from the sawmill and remove any sawdust buildup. Soak the felt wiper with Dexron III transmission fluid, 10W30 motor oil or 3-in-1 turbine oil.



CAUTION! Reinstall the track wiper so that it lightly touches the track rail. If the wiper presses too firmly against the rail, it can cause the power feed to bind.

3. Check the track scrapers as needed. Make sure the scrapers fit firmly against the rail. If a track scraper needs to be adjusted, loosen the thumb screw, push the scraper downward until it fits firmly against the rail, and retighten the thumb screw.

AR

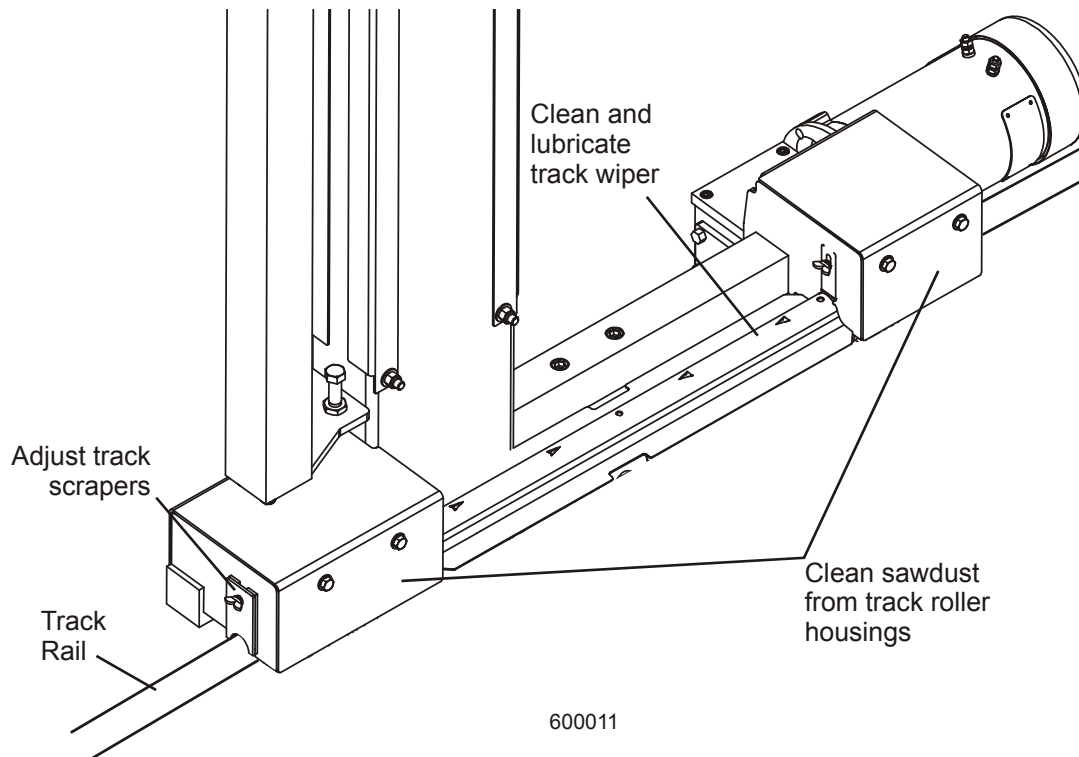

FIG. 5-3

5.5 Vertical Mast Rails

50 Clean and lubricate the vertical mast rails every 50 hours of operation. Use a light-grade sandpaper to remove any rust from them. Lubricate the mast with light oil (ATF).



CAUTION! Never use grease on the mast rails as it will collect sawdust.

5.6 Miscellaneous

1. Oil all chains with Dexron III ATF every fifty hours of operation.

50



CAUTION! Do not use chain lube. It causes sawdust buildup in chain links.

2. Apply a thin film of a NLGI No. 2 grade lithium grease to the blade guide arm every fifty hours of operation to help prevent it from rusting.

50

3. Adjust the blade guide arm drive chain as necessary. To adjust the chain, loosen the blade guide arm motor mounting plate bolts and slide the motor to take slack out of the chain.

AR

4. Grease the clamp mechanism, loading arms and side supports with a NLGI No. 2 grade lithium grease every fifty hours of operation.

50

5. Check the mill alignment every setup ([See Section 7](#)).

6. Grease the blade tensioner screw thread.

AR

See Figure 5-4.

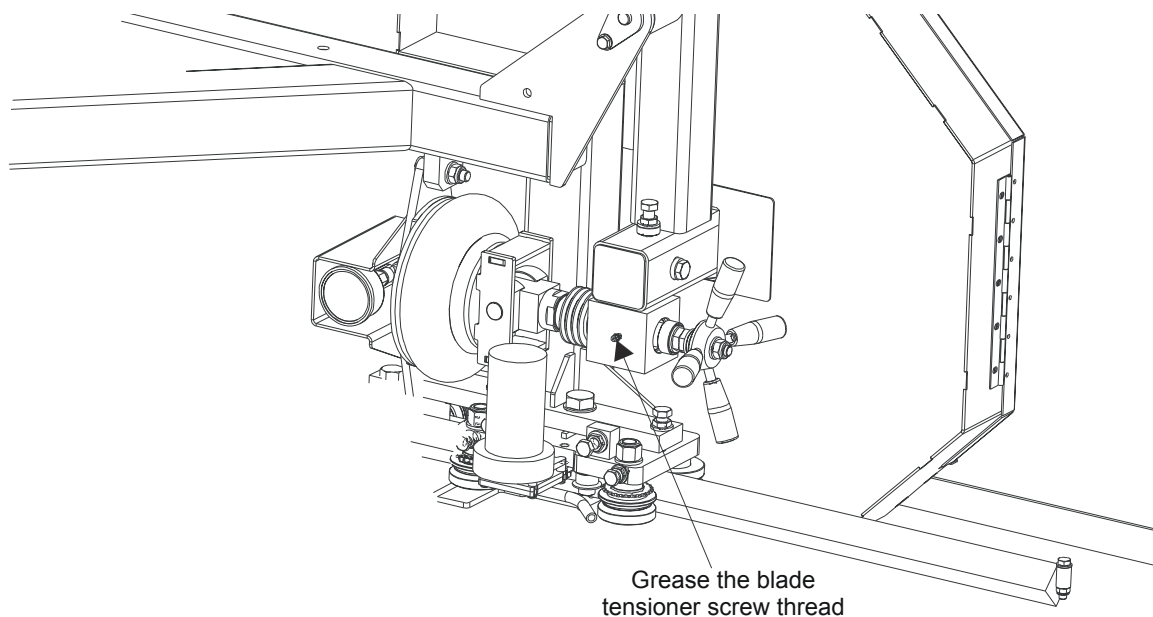

FIG. 5-4

7. Make sure all safety warning decals are readable. Remove sawdust and dirt. Replace any damaged or unreadable decals immediately. Order decals from your Customer Service

Representative.

5.7 Drive Belt Adjustment



WARNING! Never adjust the drive belts and the drive belt bracket while the motor is running. Failure to do so may result in serious injury.



Periodically check the drive belt for wear. Replace any damaged or worn belts as needed.

See Figure 5-5. Using the bolt located between the drive-side wheel covers, adjust the drive belt tension properly. Turn this bolt clockwise to increase the belt tension,

5 Maintenance

Drive Belt Adjustment

counterclockwise to reduce the tension.

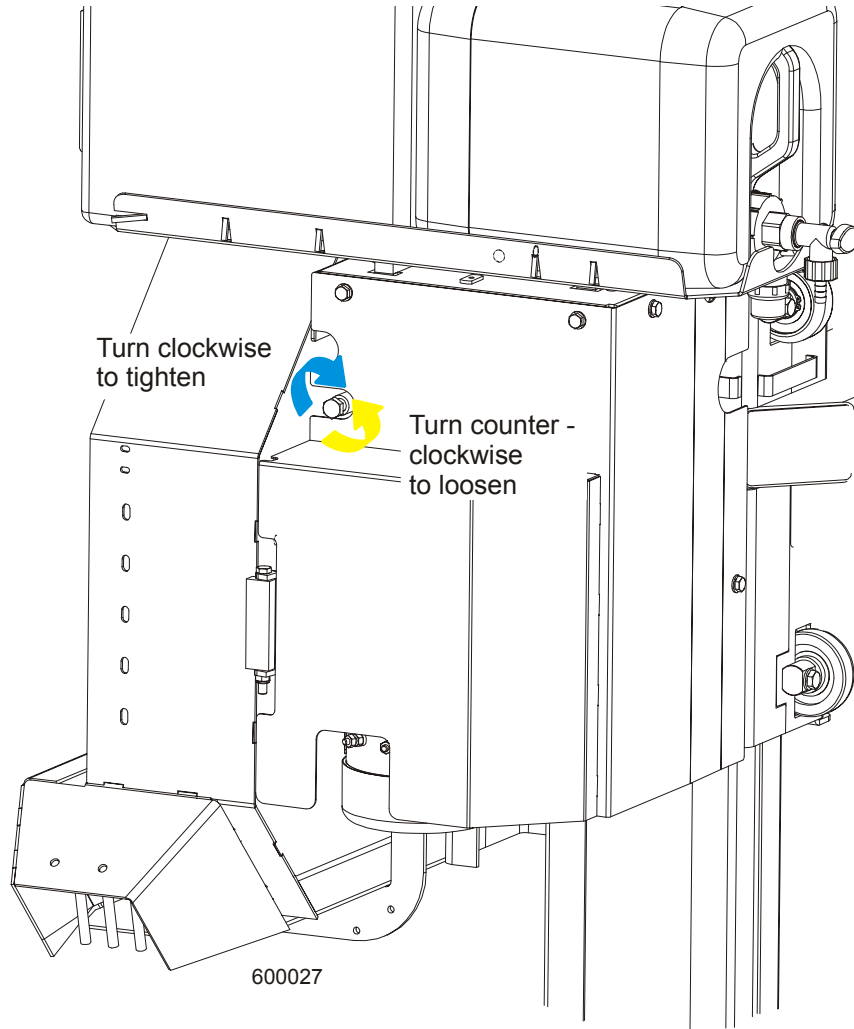

FIG. 5-5

5.8 Hydraulic System

1. Check the hydraulic fluid level every fifty hours of operation. Add fluid as necessary. The level in the hydraulic pump should be 3/4" (19mm) from the top with all cylinders collapsed.

If humidity is a problem or the mill is used outside in humid weather, drain and replace two quarts (.95 liters) of fluid every six months. This will drain any accumulated water and help prevent pump failure due to water ingestion. It also will prevent excessive fluid wear and allow the fluid to maintain its hot end performance. If humidity is not a problem, drain and replace one gallon (3.8 liters) of fluid every year to prevent fluid wear.

See Figure 5-6. If you are operating in temperatures -20° to 100° F (-29° to 38° C), use an all-weather hydraulic fluid such as Exxon Univis J26. For alternate fluids and/or other temperature ranges, refer to the chart below. Operating above the recommended temperature range of a fluid could result in premature pump wear. Operating below the recommended temperature range could cause the fluid to thicken and could result in reduced hydraulic cylinder speed. To replace the current fluid with fluid of another type, drain the old fluid and refill the tank with about 1 gallon (4 liters) of the new fluid.

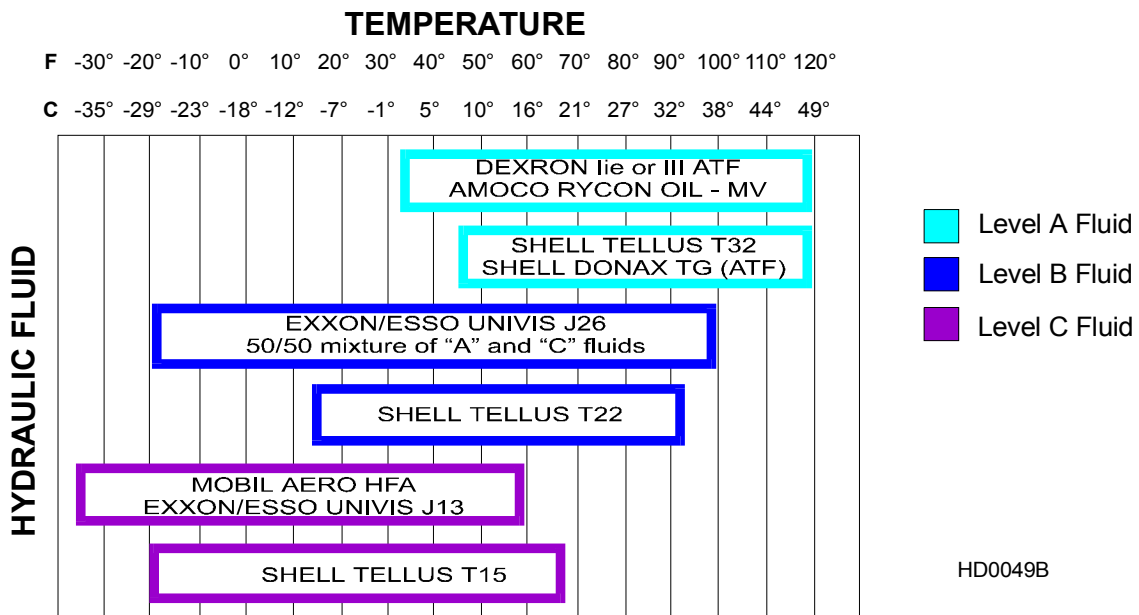

FIG. 5-6

2. Replace the hydraulic system filter every 500 hours of operation.
3. Periodically check all hydraulic lines and fittings. Replace as necessary.

5.9 Up/Down System

Adjust the up/down chain tension as needed. Measure chain tension with the head all the way to the top of the vertical mast. Find the chain adjusting bolt at the bottom of the mast. Use the adjustment nut to adjust the bolt until the center of the chain can be deflected 3/4" (1.9 cm) with a 5 lb. (2.3 KG) deflection force.



CAUTION! Do not over-tension the chain. Over-tensioning the chain may lead to early failure of the gear reducer.

See Figure 5-7.

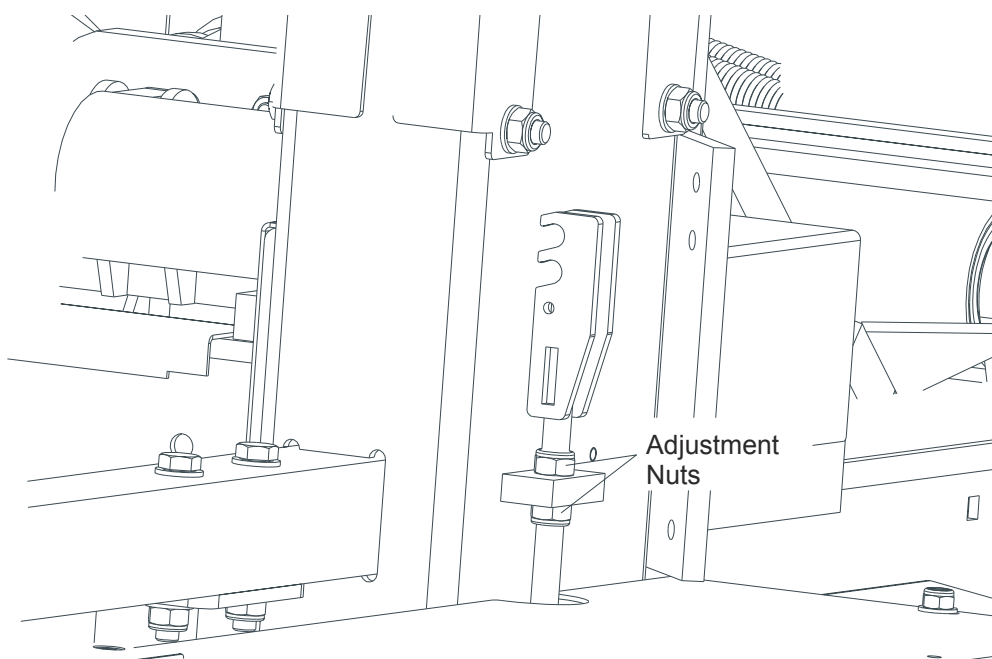

FIG. 5-7

4. Adjust the motor belt tension as needed. To do this, loosen the bolts in the motor mounting plate and turn the adjustment bolts clockwise or counterclockwise evenly until the belt is properly tensioned. Tighten the motor mounting bolts.

See Figure 5-8.

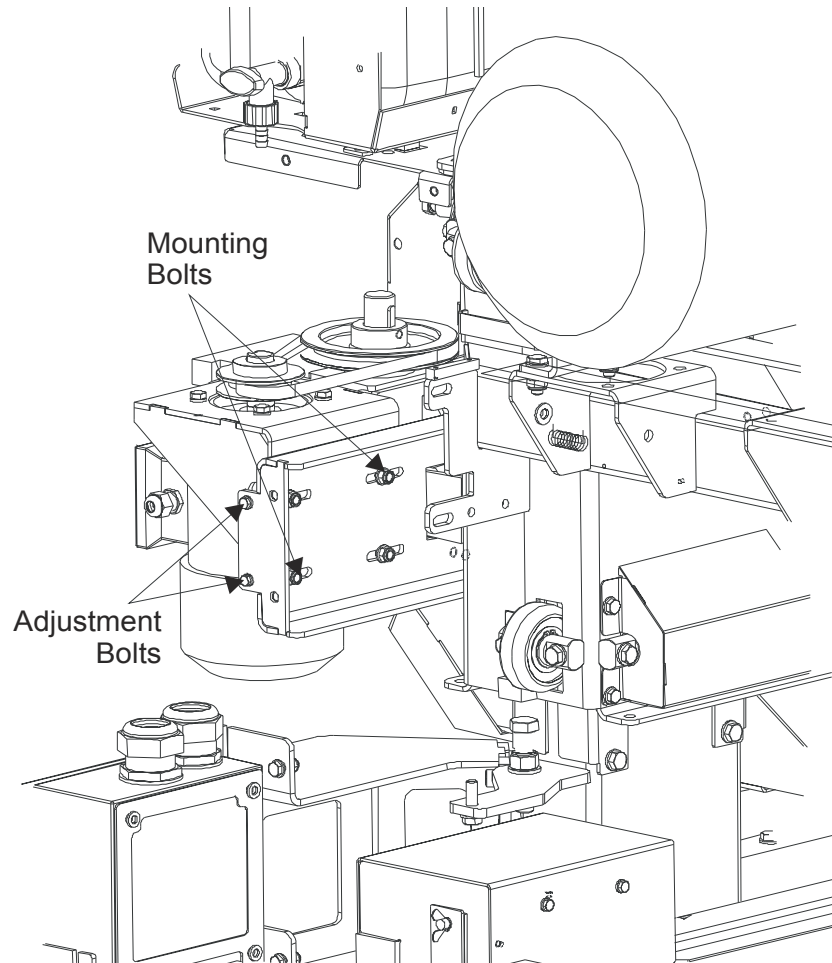

FIG. 5-8

Periodically check the belt for wear. Replace any damaged or worn belts as needed.

AR

5. If oil leaks from the gear box, contact Wood-Mizer Customer Service.

5.10 Power Feed System

1. Adjust the power feed chain tension as needed. Measure it with the saw head all the way toward the front of the mill. Use the adjustment nut on the feed tensioner at the front of the mill to tighten or loosen the power feed chain. Adjust the chain until it measures about 5.5", i.e. 14 cm (in the case of S or M type bed frame) or about 7.5", i.e. 19 cm (in the case of L type frame) from the top of the top rail at its lowest point.



CAUTION! Do not overtighten the feed chain. Damage to the gear reducer may result.

See Figure 5-9.

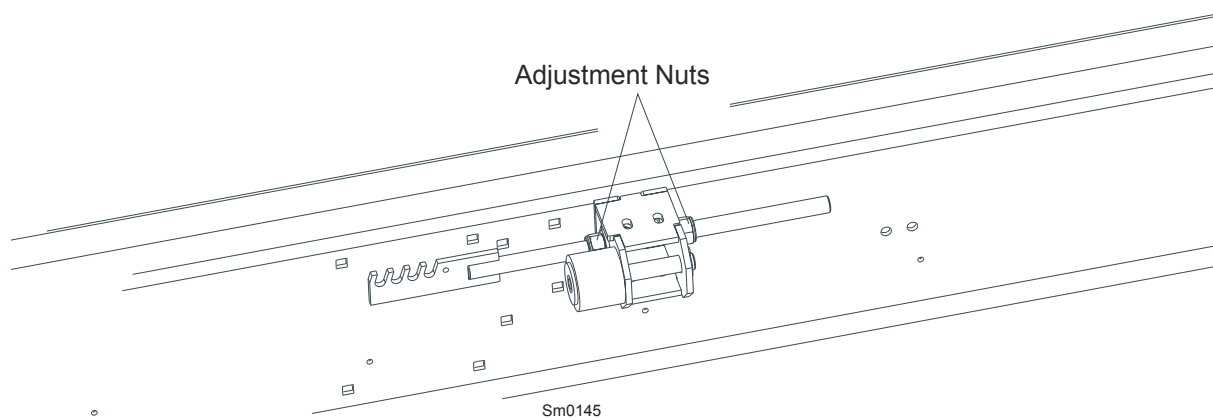

FIG. 5-9

2. If oil leaks from the gear box, contact Wood-Mizer Customer Service.

750

SECTION 6 TROUBLESHOOTING GUIDE

6.1 Sawing Problems

PROBLEM	CAUSE	SOLUTION
BLADES DULL QUICKLY	Dirty logs.	Clean or debark logs, especially on entry side of the cut.
	When grinding teeth, heating too much and causing teeth to soften.	Grind just enough metal to restore sharpness to the teeth. Use water/coolant while sharpening blade.
BLADES BREAK PREMATURELY	Poor sharpening techniques.	See Sharpener Manual.
	Rubber belts on blade wheels worn to a point that blade contacts metal pulley - look for shiny spots on edge of wheels.	Replace B-57 belts.
	Poor sharpening techniques.	See Sharpener Manual.
	Tension too tight.	Tension blade to recommended specifications.
	Cutting with dull blade for too long.	See Blade Handbook.
	Blade guides not properly aligned.	Patrz Rozdział Prowadniki piły
BLADE DOES NOT TRACK RIGHT ON DRIVE WHEEL	Cant adjustment is incorrect.	Readjust.
	Worn blade wheel belts.	Replace B-57 belts.
BLADE GUIDE ROLLERS DO NOT SPIN WHILE CUTTING	Frozen bearings.	Try to defrost the bearings (e.g. with warm air).
	Stiff bearings.	Replace blade guide rollers.
FLAT (WORN) SURFACES ON BLADE GUIDE ROLLERS	Rollers did not spin for a longer period of time during sawmill operation.	Replace blade guide rollers.
BLADE DOES NOT STOP SEVERAL SECONDS AFTER DISENGAGING	Motor brake improperly adjusted.	Adjust the air-gap between the brake friction linings (See Motor Manual).
DRIVE BELTS COME OFF PULLEYS WHEN DISENGAGING BLADE	Motor brake improperly adjusted.	Adjust the brake air-gap (See Motor Manual).
DRIVE BELTS WEAR PREMATURELY OR JUMP	Motor and drive pulleys out of alignment.	Align pulleys <i>Patrz Rozdział "6.4" Regulacja ustawienia koła pasowego silnika (wyłącznie traki AC).</i>

6

Troubleshooting Guide

Sawing Problems

PROBLEM	CAUSE	SOLUTION
BOARDS THICK OR THIN ON ENDS OR MIDDLE OF BOARD	Stress in log which causes log to not lay flat on the bed.	After log has been squared, take equal cuts off opposing sides. Take a board off the top. Turn the log 180 degrees. Take a board off. Repeat, keeping the heart in the middle of the cant, and making it your last cut.
	Tooth set is incorrect.	Resharpener and reset blade properly.
HEIGHT ADJUSTMENT JUMPS OR STUTTERS WHEN MOVING UP OR DOWN	Bed rails misaligned.	Realign bed.
	Vertical mast needs lubrication.	Lubricate mast track surface (e.g. with WD40 or machine oil).
LUMBER IS NOT SQUARE	Up/down chain improperly adjusted.	Adjust up/down chain.
	Up/down belt loose.	Tension belt properly.
LUMBER IS NOT SQUARE	Vertical side supports not square to bed.	Adjust side supports.
	Blade not parallel to bed rails.	Adjust bed rails parallel to blade.
SAWDUST AND DUST BUILDS UP ON TRACK	Sawdust or bark between cant and bed rails.	Remove particles.
	Track wipers do not work properly.	Adjust wipers to firmly contact track or replace them.
WAVY CUTS	Track is dirty.	Clean track and apply silicone spray.
	Feed speed is too high.	Slow down feed rate.
WAVY CUTS	Improperly sharpened blade (This will be the problem 99% of the time!).	Resharpener blade (See Sharpener Manual - read entire manual!).
	Blade guides improperly adjusted.	Adjust blade guides.
WAVY CUTS	Sap buildup on blade.	Use Water Lube.
	Tooth set problem.	Resharpener and reset blade.

CONTROL UNIT DOES NOT
WORK PROPERLY

Perform the following RESET
procedure.

Turn off the power. Press and
hold REF LOCK + MANUAL
buttons. Turn on the power.

ATTENTION! All user settings
(boards thicknesses etc.) will be
lost.

6.2 Power Feed Problems

PROBLEM	CAUSE	SOLUTION
POWER FEED IS JERKY AT LOW SPEEDS OR DOES NOT MOVE AT ALL	Loose components or wire terminals.	Have the control box checked/repaired.
	Feed rate dial is worn.	Replace feed rate dial.
	Speed controller is locked.	Turn off power supply for 20 seconds and then turn it on again.
		Check wire connections in electrical cabinet (CAUTION! Before checking, disconnect electrical power to the machine!).
		One or two phases lack power.
POWER FEED IS JERKY, BUT POWER FEED MOTOR RUNS PROPERLY AT ALL SPEEDS	Problem is mechanical.	Perform the Mechanical Test. Patrz Rozdział 6.5 Power Feed Mechanical Test

PROBLEM	CAUSE	SOLUTION
POWER FEED MOTOR OVER-HEATS (MOTOR TEMPERATURE IS ABOVE 75°C)	Middle track oiler is dragging.	Clean and lubricate the middle track oiler. Allow motor to cool before restarting.
	Ground is not level.	Level the sawmill. Allow motor to cool before restarting.
	Track roller bearing drag is excessive.	Replace the roller. Allow motor to cool before restarting.
	Chain is dragging.	Make sure chain is centered on idler; Clean and lubricate chain; Adjust chain tension. Allow motor to cool before restarting.
	Chain is improperly tensioned.	Adjust chain tension. Allow motor to cool before restarting.
	Power feed is binding.	Check condition of bearings and sprocket as well as power feed chain tension. Allow motor to cool before restarting.
	Saw head load is excessive.	Avoid unnecessary modifications to saw heads that would give them extra weight. Allow motor to cool before restarting.
Blade is dull or improperly set.	Use proper blade maintenance procedures (See Sharpener or Toothsetter manual). Allow motor to cool before restarting.	

6.3 Hydraulic Problems

PROBLEM	CAUSE	SOLUTION
YOU CAN ACTUATE ANY HYDRAULIC HANDLE, BUT GET NO RESPONSE FROM THE PUMP	Carriage not positioned properly to provide power to the pump.	Move the saw carriage so that it contacts the hydraulic power supply strip. Check the connection. Clean as necessary.
	Hydraulic pump motor does not work.	Check if the key switch is in the "1" position. Make sure the emergency stop switch is not engaged. Check if BED MODE is active, i.e., if the yellow BED light is on.
	One phase lacks power.	Check fuses in the external power source.
	Pump motor contactor is bad.	Have a qualified electrician replace it.
	Hydraulic pump motor is overheated.	Allow motor to cool. Turn off power supply and reset the motor thermal protection located inside the main electrical cabinet.
	Hydraulic pump motor works after releasing the joystick.	Normal situation. The hydraulics should keep working for 5 to 8 seconds after the joystick has returned to the neutral (middle) position.
	Defective pump motor.	Remove motor from pump and inspect. Repair or replace as necessary.

PROBLEM	CAUSE	SOLUTION
PUMP MOTOR RUNS WITH LITTLE OR NO RESPONSE FROM THE CYLINDERS	Low hydraulic fluid level.	Check fluid level. Add an all-season hydraulic fluid such as Amoco Rycon Oil MV, Mobil Multipurpose ATF (automatic transmission fluid) or Exxon/Esso Univis J26 until level is .75" (19 mm) from top of reservoir with all cylinders retracted.
	Pressure relief valve moved from proper setting.	Adjust pressure relief valve. It can be done by Wood-Mizer Customer Service only.
	Low air temperature causing hydraulic fluid to thicken.	Allow fluid to warm up. Synthetic fluids are available that allow for hydraulic operation in cold weather conditions (Mobil SHC 526).
PUMP MOTOR RUNS CONTINUOUSLY WHEN POWER CONTACT IS MADE	Solenoid is stuck closed.	Tapping the solenoid may solve this problem temporarily. Replace solenoid.
FLUID LEAKS FROM AROUND CYLINDER PISTON RAM	Worn seals.	Replace seals in cylinder. Check piston ram for abrasive weld that may be causing premature seal failure.
FLUID LEAK AROUND PUMP BOX	Loose seal or fitting.	Wipe pump off completely to locate cause of leak. You may have to unbolt the pump to wipe behind it. NOTE: Movement of the sawmill can cause fluid to slosh up into the foam filter in the reservoir cap, and subsequently spray out, giving the appearance that fluid is leaking from the pump.

PROBLEM	CAUSE	SOLUTION
HYDRAULIC SIDE SUP- PORTS GO DOWN BEFORE OR AT SAME TIME AS LOG TURNER	Dirt in sequence valve.	Remove sequence valves and clean thoroughly with kerosene. NOTE: Be sure to reassemble the valve and install it in its original position on the cylinder.
	Retainer in sequence valve worn.	Replace sequence valve.
HYDRAULIC TURNER GOES UP BEFORE OR AT SAME TIME AS SIDE SUPPORTS	Low air temperature causing fluid to thicken.	Allow fluid to warm up. Synthetic fluids are available that allow for hydraulic operation in cold weather conditions (Mobil SHC 526).
	Spring weakening in sequence valve.	Locate sequence valve at top of turner cylinder. Turn heavy spring in about 1/4 turn.
	Dirt in sequence valve.	Remove sequence valves and clean thoroughly with kerosene. NOTE: Be sure to reassemble the valve and install it in its original position on the cylinder.
	Retainer in sequence valve worn.	Replace sequence valve.
	Low air temperature causing fluid to thicken.	Allow fluid to warm up. Synthetic fluids are available that allow for hydraulic operation in cold weather conditions. (Mobil SHC 526).
	Spring weakening in sequence valve.	Locate sequence valve at bottom of turner cylinder. Turn heavy spring in about 1/4 turn.

HYDRAULIC TOE BOARDS OR CLAMP "CREEP" DOWN WITHOUT THE JOYSTICK BEING OPERATED OR DO NOT RAISE OR LOWER AT ALL

Can be a result of failing to lower completely the toe board/log clamp before loading the log and hitting the toe board/log clamp by the log being loaded (which can cause damage to the toe board/log clamp and the sawmill bed).

- Damaged hoses;
- Damaged cylinder seals or cylinder;
- Damaged hydraulic valve;
- Damaged check valve.

INITIAL CHECK

To check, disconnect the toe board hydraulic hose from its current valve section and temporarily connect it to another valve section. Check to see if the hydraulics operate properly.

If hydraulics operate properly, hoses and cylinder seals are good. Perform further valve inspection, found below.

If down creep still occurs, check all hoses for possible pinholes causing leakage. Replace if applicable. Retest.

If down creep still occurs, replace cylinder seals or cylinder and retest. Be sure to reconnect the hose to the proper valve section when done.

FURTHER VALVE INSPECTION

If further inspection of the valve is required after initial check, remove the check valve shown below. Flush the check valve with an air hose or solvent to remove any dirt from the valve's seat. Reinstall and test again. Check to see if the hydraulics operate properly.

If down creep still occurs, replace the check valve with a new one. Retest. **If down creep still occurs**, replace the hydraulic valve section.

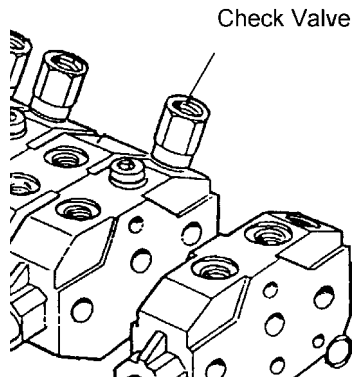

Bad check valve (results in one of the toe boards experiencing down-creep). Replace either only the check valve or the entire hydraulic valve section.

6.4 Motor And Drive Pulleys Alignment (AC Sawmills Only)



WARNING! Do not for any reason adjust the motor drive belts or belt support bracket with the motor running. Doing so may result in serious injury.

1. Install and tension properly the drive belt ([See Section 5.9](#)).
2. Check if the motor pulley and the drive pulley are aligned to each other. If they are not, loosen the motor mounting plate bolts and move the motor until the motor pulley is aligned to the drive pulley. Retighten the motor mounting bolts.
3. Make sure the motor mounting bolts and the pulley bushing bolts are tightened enough.
4. When the alignment is complete, check the drive belt support bracket and adjust it if necessary ([See Section 5.9](#)).

6.5 Power Feed Mechanical Test

1. If on the saw head there is anything other than its components, remove it.
2. Make sure the middle track cover is not bent or touching the top rail.
3. Make sure the middle track oiler is free of sawdust buildup.
4. Make sure the power feed chain is not stiff from rust. Also make sure the chain is not too tight.
5. Make sure there is no sap or rust on the rails.

6.6 Hydraulic Pressure Test

Perform the procedure described below to check, and adjust the hydraulic pressure, if necessary.

See Figure 6-10.

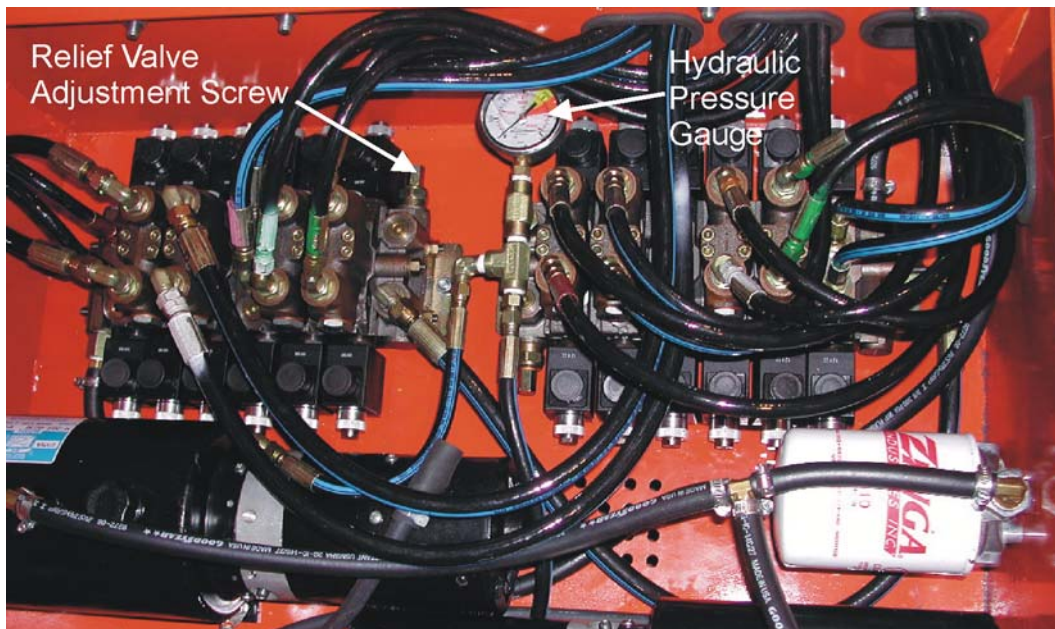

FIG. 6-10

Activate BED mode ([Patrz Rozdział 4.2.1 Funkcje hydrauliki](#)). Then engage any of the log handling units except for the log turner. Wait until the cylinder is all the way out. When the cylinder is in this position, the hydraulic pressure will start increasing and the pressure relief valve will open. With the relief valve opened, check the hydraulic pressure shown on the hydraulic pressure gauge and adjust it if necessary. The hydraulic pressure is factory-set at 2200 psi (15,17 MPa) and should not need to be readjusted. The relief valve adjustment bolt shown may be used to fine-tune the hydraulic pressure:

Remove the adjustment bolt nut. Turn the adjustment bolt clockwise to increase the pressure or counterclockwise to decrease the pressure.



CAUTION! Pressure should not exceed 2200 psi (15,17 MPa). If it does, temperatures of the hydraulic pump motor and hydraulic fluid will rise. This may result in fluid overheating and may cause damage to the hydraulic cylinders and hoses.

SECTION 7 SAWMILL ALIGNMENT

The Wood-Mizer sawmill is factory aligned. Two alignment procedures are available to realign the sawmill if necessary. The Routine Alignment instructions should be performed as necessary to solve sawing problems not related to blade performance. The Complete Alignment procedure should be performed approximately every 1500 hours of operation (sooner if you regularly transport the sawmill over rough terrain).

WARNING! Always wear eye, ear, respiration and foot protection as well as safety clothing when servicing the sawmill.



7.1 Routine Alignment Procedure

Blade Installation And Tracking

1. Remove the blade and check the blade wheels. Remove any sawdust buildup from the surface of the wheels.
2. Install a clean blade and apply the appropriate tension ([See Section 3.4](#)).
3. Check that the blade guides are properly adjusted ([Patrz Rozdział Prowadniki pily](#)).
4. Adjust the horizontal tilt of the idle-side blade wheel to track the blade ([See Section 3.5](#)).
5. Close the blade housing covers and make sure all persons are clear of the saw head.
6. Turn the key switch to the #2 position.
7. Manually spin one of the blade wheels until the blade positions itself on the blade wheels.



7 SAWMILL ALIGNMENT

Saw Head Tilt

Saw Head Tilt

As the blade enters a wide log or cant, the outside of the saw head will drop down slightly. To compensate for the drop, the saw head is adjusted 1/16" (1.5 mm) higher at the outside.

1. Move the saw carriage so the blade is positioned over a bed rail. Adjust the blade guide arm to 1/2" (15 mm) from full open.
2. Raise the saw head so the bottom of the blade measures 14 3/4" (375 mm) from the top surface of the bed rail near the inner blade guide assembly.

See Figure 7-1.

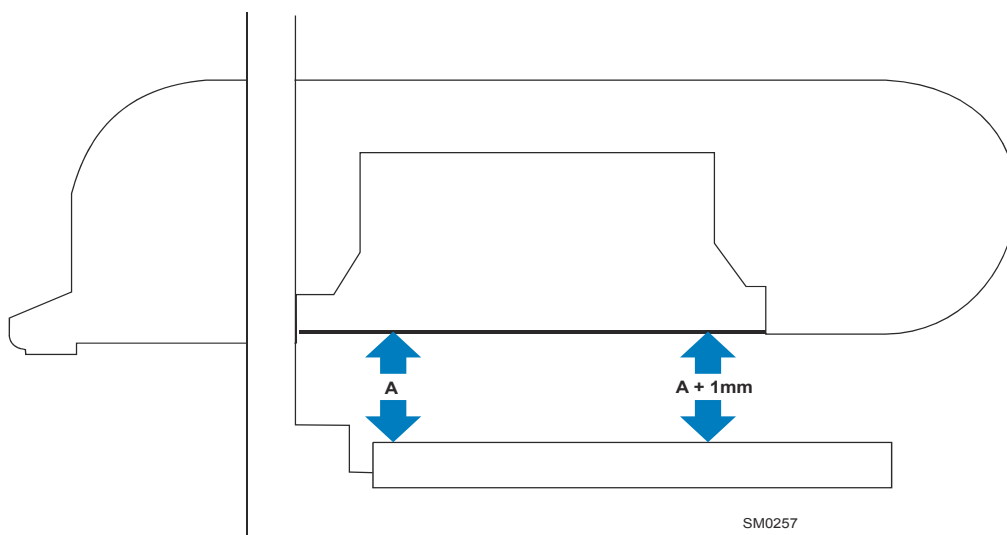

FIG. 7-1

3. Measure from the blade to the bed rail near the outer blade guide assembly. This measurement should be 1/16" (1.5 mm) higher than the inner measurement or 14 13/16" (376.5 mm).

See Figure 7-2. To adjust the saw head tilt, use the bolts located at the bottom of the saw head mast. Loosen the three sets of four retaining plate bolts. To raise the outside of the saw head, back the stop bolts out, then tighten the adjustment bolts. To lower the outside of the saw head, loosen the adjustment bolts and tighten the stop bolts. Then recheck the measurement from the blade to the bed rails near the outer blade guide. Adjust the stop bolts and adjustment bolts as necessary, until the outside of the saw head is 1/16"

(1.5 mm) higher than the inside. Retighten the retaining plate bolts.

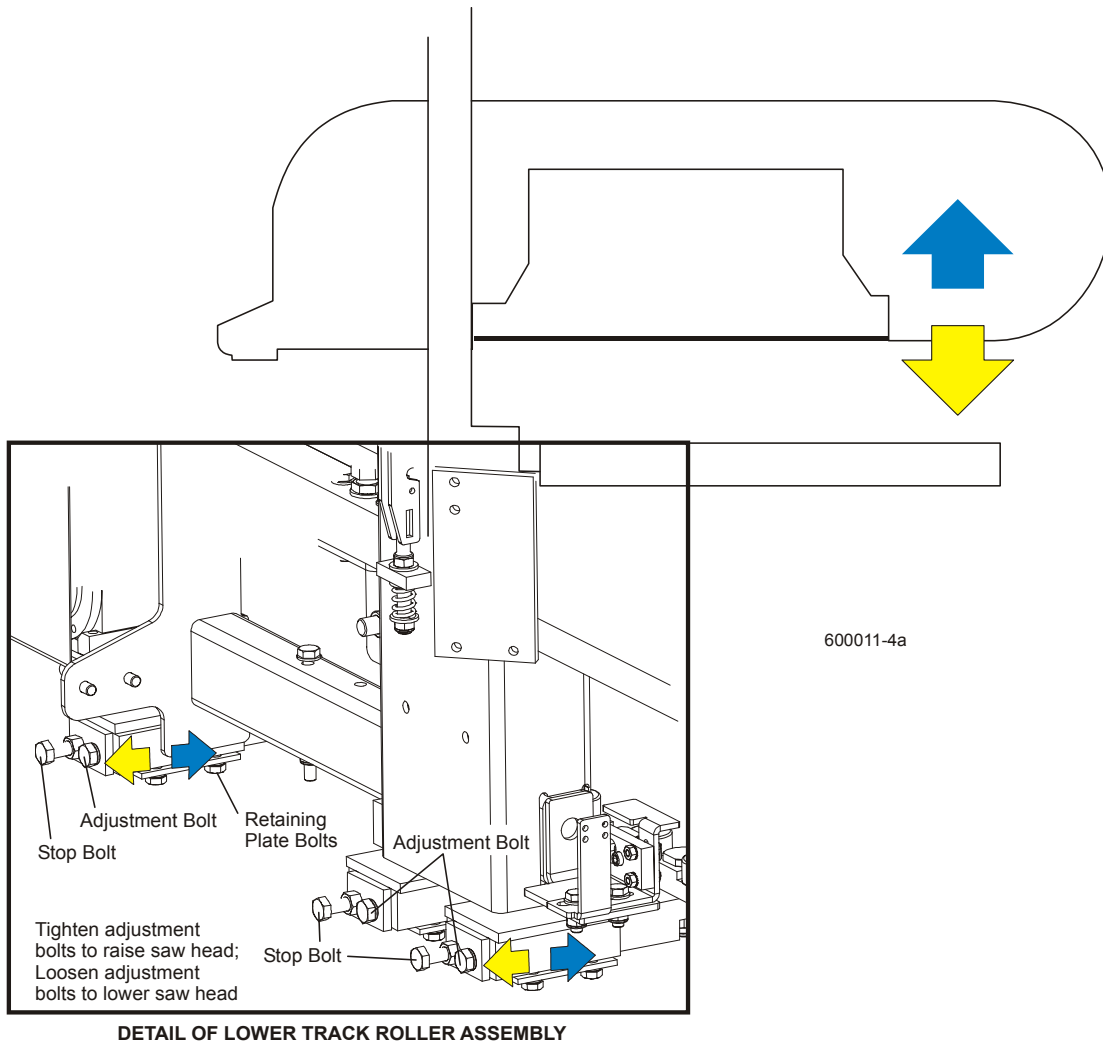

FIG. 7-2

7 SAWMILL ALIGNMENT

Blade Guide Arm Alignment

Blade Guide Arm Alignment

The blade guide arm moves the outer blade guide in and out. If the arm becomes loose, the blade guide will not deflect the blade properly, causing inaccurate cuts. A loose blade guide arm can also cause blade vibration.

1. Adjust the blade guide arm in to 1/2" (15 mm) from fully closed.
2. Manually try to move the arm up and down. If you can move the arm by hand, you will need to tighten the arm rollers.

See Figure 7-3. Loosen the jam nuts and turn the adjustment bolts in to tighten the blade

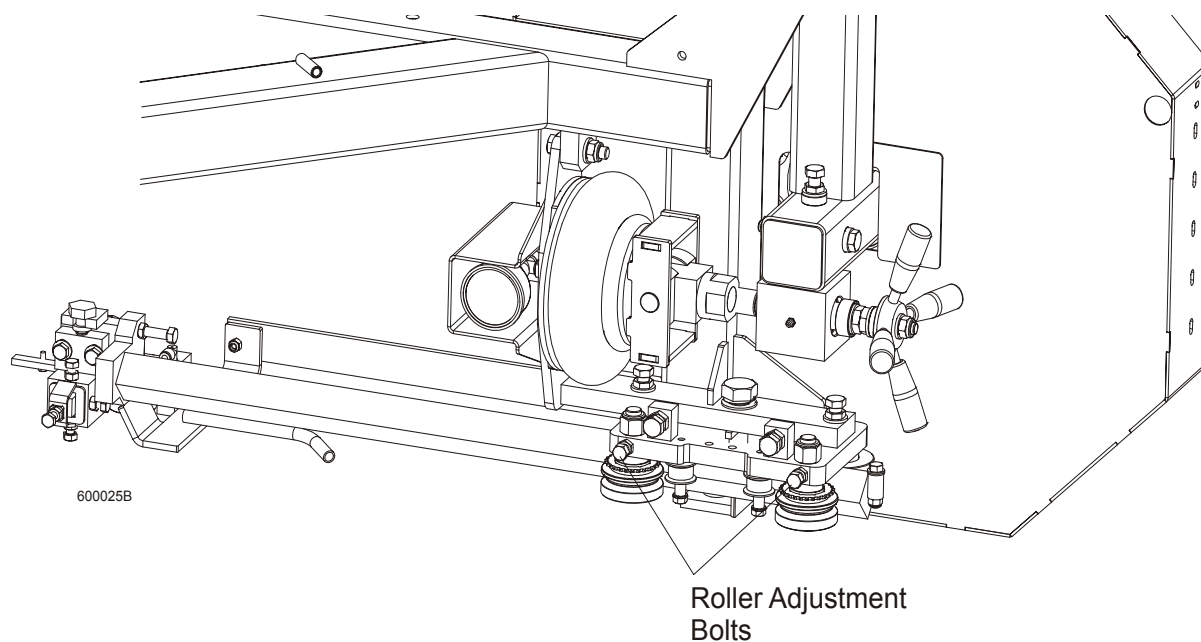

FIG. 7-3

guide arm rollers. Retighten the jam nuts.

After tightening the blade guide arm rollers, check that the arm is aligned properly.

Blade Guides

3. With the arm adjusted 1/2" (15 mm) from fully closed, measure the distance between the blade guide roller flange and the blade. If the sawmill is equipped with optional blade guides (with two guide inserts in each blade guide), measure from the blade to the guide roller.

See Figure 7-4.

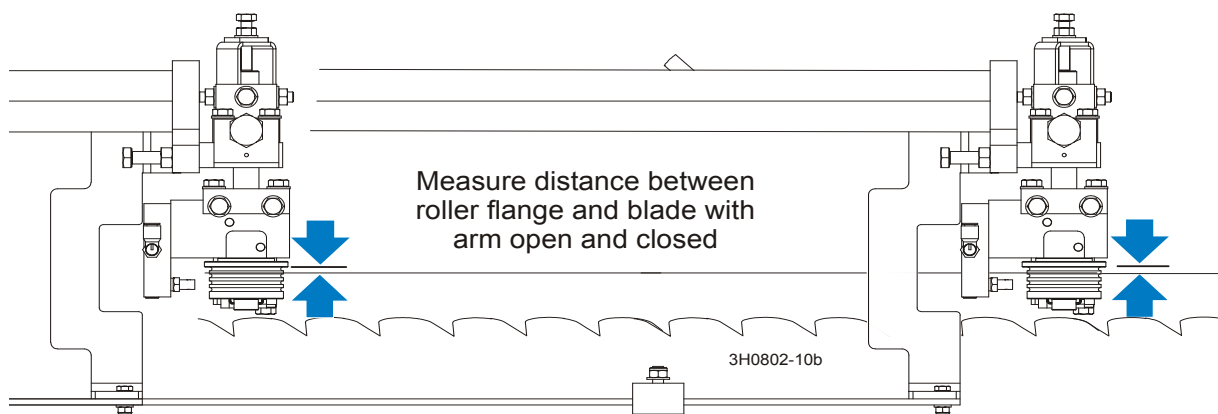

FIG. 7-4

4. Adjust the blade guide arm to 1/2" (15 mm) from fully open and remeasure the distance from the roller flange to the blade. The two measurements should be the same. If not, adjust the horizontal tilt of the blade guide arm.

See Figure 7-5. Loosen the jam nuts on the adjustment bolts shown in the figure below. To tilt the arm in toward the blade, loosen the right bolt and tighten the left bolt. To tilt the arm out away from the blade, loosen the left bolt and tighten the right bolt. Retighten the

7 SAWMILL ALIGNMENT

Blade Guides

jam nuts and recheck the blade guide arm horizontal tilt.

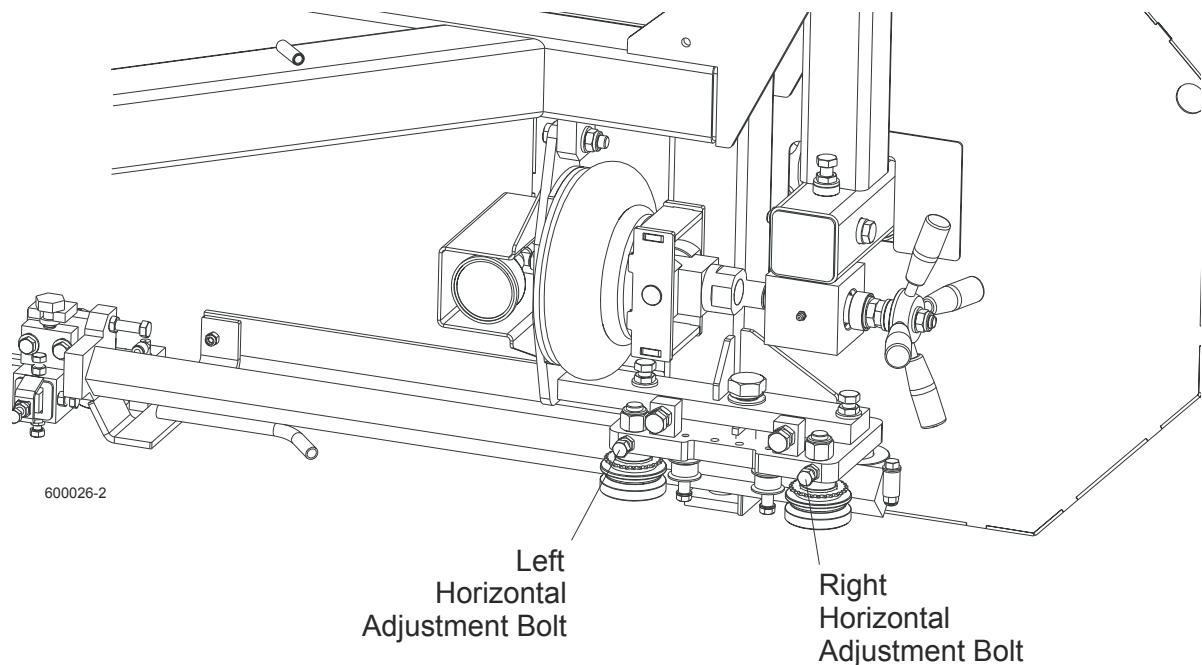

FIG. 7-5

5. Now check the vertical tilt of the blade guide arm. Move the saw carriage so the blade guide arm is positioned over a bed rail.
6. With the arm 1/2" (15 mm) from fully closed, raise or lower the saw head until the bottom of the blade guide mounting block is 15" (375 mm) from the top of the bed rail.

See Figure 7-6.

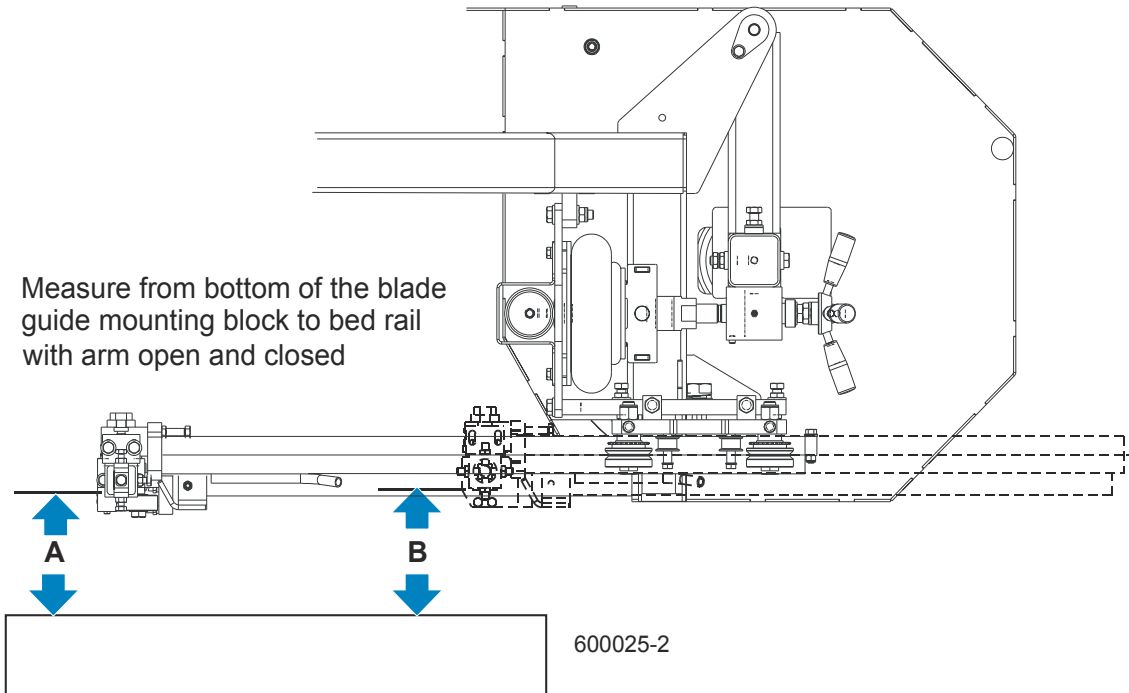

FIG. 7-6

7. Adjust the blade guide arm to 1/2" (15 mm) from fully open. Measure the distance from the bottom of the blade guide mounting block to the bed rail. This measurement should be 15" (375 mm) or slightly higher because the saw head is tilted up 1/16" (1.5 mm) on the outside ([Patrz Saw Head Tilt](#)). If the blade guide mounting block is closer to the bed rail or more than 1/16" higher with the arm open, adjust the blade guide arm vertically.

See Figure 7-7. Loosen the vertical adjustment bolt jam nuts. To tilt the blade guide arm down, loosen the right bolt and tighten the left bolt. To tilt the blade guide arm up, loosen the left bolt and tighten the right bolt. Retighten the jam nuts and recheck the blade guide

7 SAWMILL ALIGNMENT

Blade Guides

arm vertical tilt.

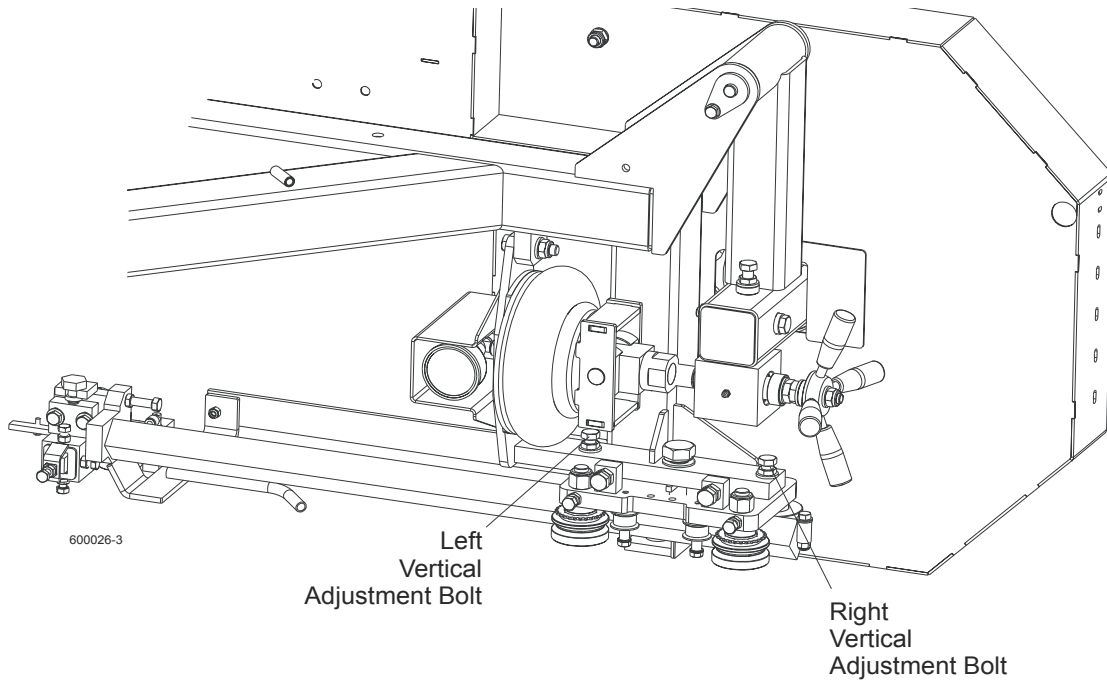

FIG. 7-7

Blade Guide Vertical Tilt Adjustment

The blade guides should be adjusted properly in the vertical plane so that the blade is parallel to the bed rails. A Blade Guide Alignment Tool (BGAT) is provided to help you measure the vertical tilt of the blade.

1. Open the adjustable blade guide arm 1/2" (15 mm) from full open.
2. Clip the alignment tool on the blade. Position the tool close to the outer blade guide assembly. Be sure the tool does not rest on a tooth or burr, and is lying flat on the blade.

See Figure 7-8.

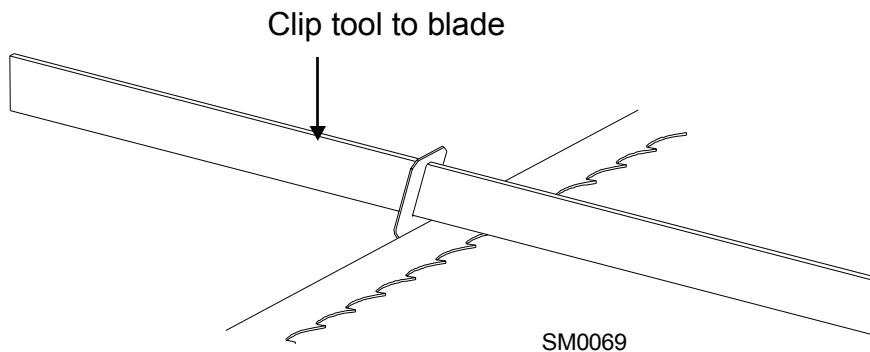

FIG. 7-8

3. Move the carriage so that the front end of the tool is positioned above the bed rail. Measure the distance from the bed rail to the bottom edge of the tool.
4. Move the carriage so that the back end of the tool is positioned above the bed rail. Measure the distance from the bed rail to the bottom edge of the tool.
5. If the measurement from the tool to the bed rail is not equal within 1/32" (.75 mm), adjust the vertical tilt of the outer blade guide roller.

7 SAWMILL ALIGNMENT

Blade Guide Vertical Tilt Adjustment

See Figure 7-9. Loosen the jam nuts on the top and bottom vertical tilt adjustment

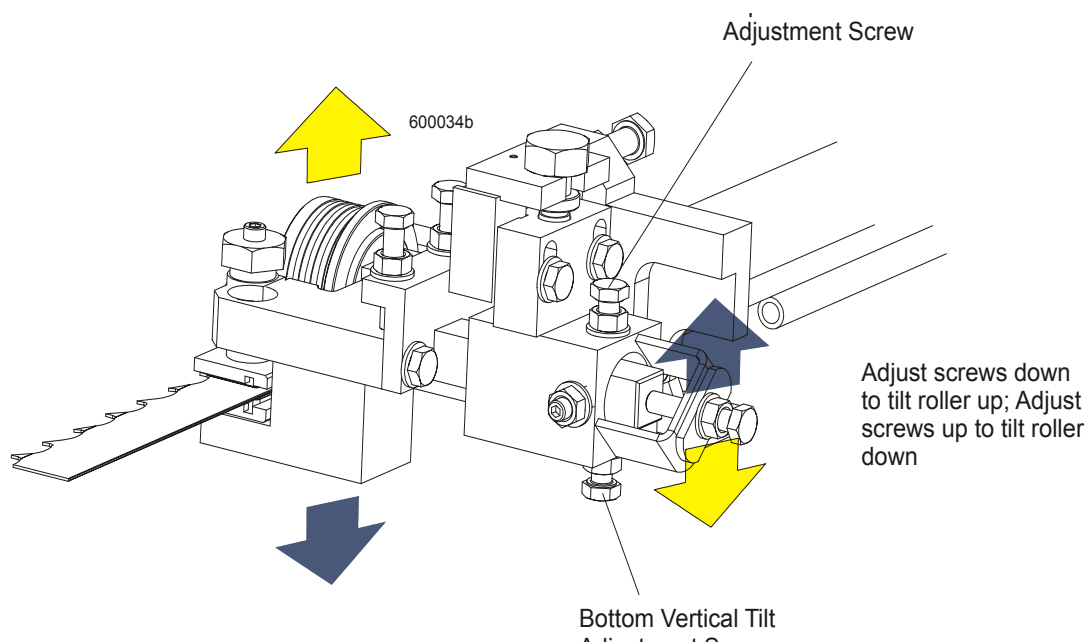

FIG. 7-9

screws. To tilt the roller up, loosen the bottom screw and tighten top screw. To tilt the roller down, loosen the top screw and tighten the bottom screw. Tighten the jam nuts and recheck the tilt of the blade.

6. Move the blade guide alignment tool close to the inner blade guide assembly and repeat the above steps. Adjust the vertical tilt of the inner blade guide if necessary.

7.1.10 Blade Guide Horizontal Tilt Adjustment

If the blade guides are tilted in the wrong direction horizontally, the back of the blade may contact the flange as the roller is spinning down, causing it to push the blade away from the guide roller. This may result in premature blade cracking.

1. Remove the blade guide alignment tool from the blade and adjust the blade guide arm halfway in.
2. Remove the clip from the blade guide alignment tool. Place the tool against the face of the outer blade guide roller.

See Figure 7-11.

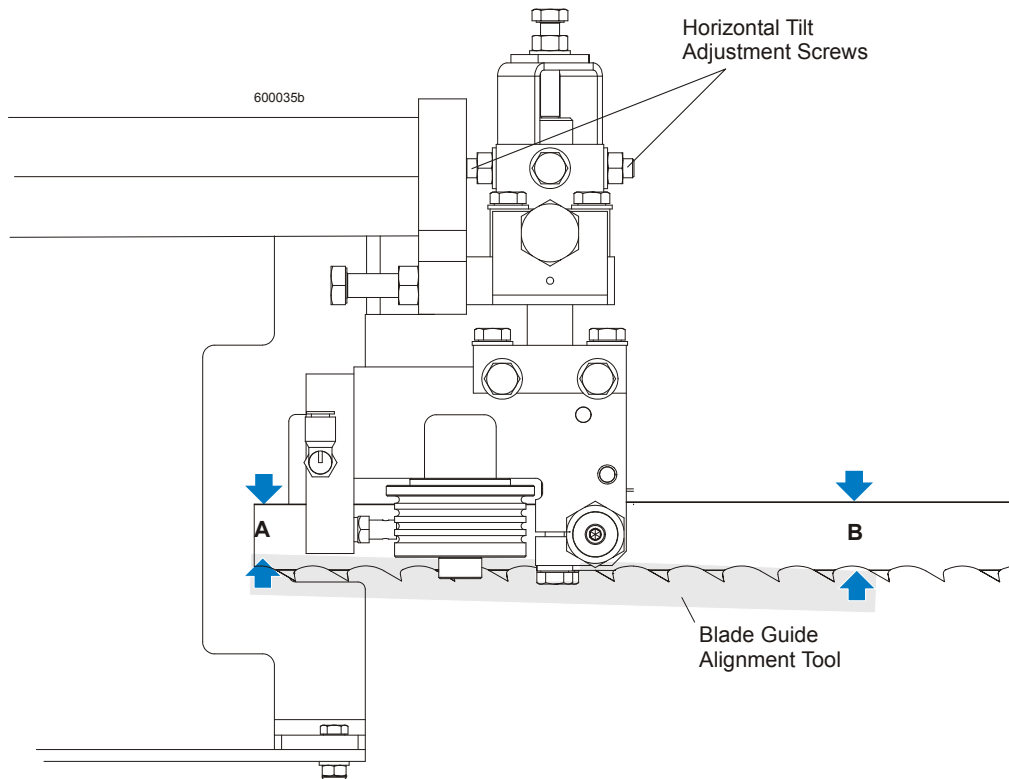

FIG. 7-11

3. Measure between the back edge of the blade and the tool at the end closest to the inner blade guide ("B").
4. Measure between the back edge of the blade and the other end of the tool ("A").

7 SAWMILL ALIGNMENT

Blade Guide Horizontal Tilt Adjustment

The roller should be tilted slightly to the left ('A' 1/8" [3 mm] less than 'B').

See Figure 7-12. Loosen the jam nuts on the horizontal tilt adjustment screws. To tilt the roller left, loosen the right screw and tighten left screw. To tilt the roller right, loosen the left screw and tighten the right screw. Tighten the jam nuts and recheck the tilt of the blade.

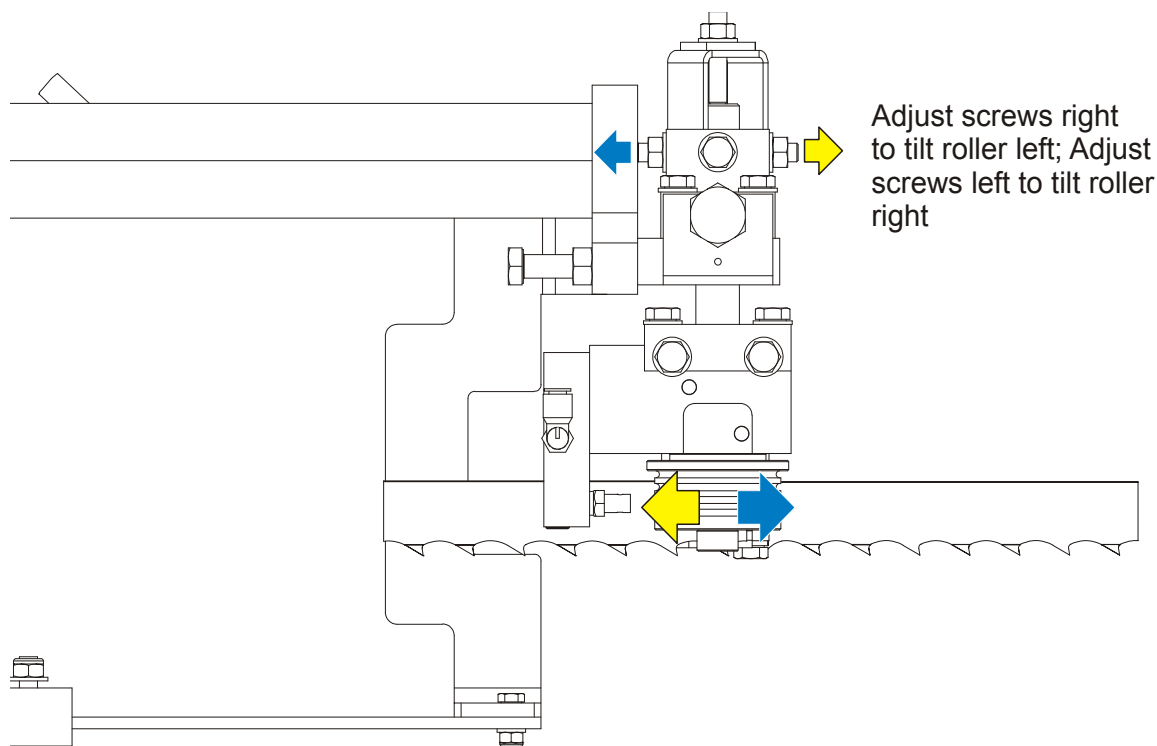

FIG. 7-12

5. Repeat the above steps for the inner blade guide roller assembly.

NOTE: Once the blade guides have been adjusted, any cutting variances are most likely caused by the blade. *Patrz Podręcznik Obsługi Piły, Form #600.*

Blade Guide Roller Flange Spacing

Each blade guide must be adjusted so the roller flange is the correct distance from the back edge of the blade. If the flange is too close to or too far from the blade, the sawmill will not cut accurately.

HINT: When adjusting blade guide spacing, loosen the top set screw and one side set screw only. This will ensure horizontal and vertical tilt adjustments are maintained when the adjustment screws are retightened.

1. Measure the distance between the flange on the inner blade guide roller to the back edge of the blade. This distance should measure 1/16" (1.5 mm). Adjust the roller back or forward if necessary.

See Figure 7-13. Loosen the top and one side set screw as well as the rear adjustment bolt if necessary. Tap the blade guide forward or backward until properly positioned.

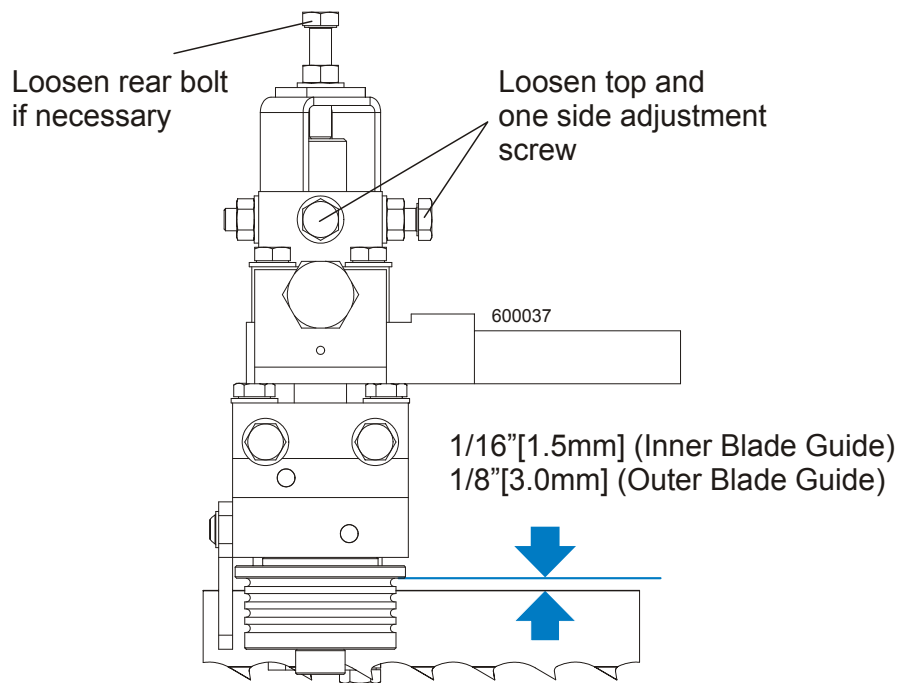

FIG. 7-13

Retighten the screws and jam nuts.

2. Measure the distance between the flange on the outer blade guide roller to the back edge of the blade. This distance should measure 1/8" (3.0 mm). Adjust the roller back or forward if necessary.

7.2 Align Side Supports

See Figure 7-1. Place two square tubes or straight board across the bed rails in front of one of the side supports. Use the controls to raise the side supports all the way up. Set a square on the tubes or board and place against the side support. The side support should be square to the bed or tilted slightly forward $1/32''$ (0.8 mm). Adjust the tilt of the side support if necessary.

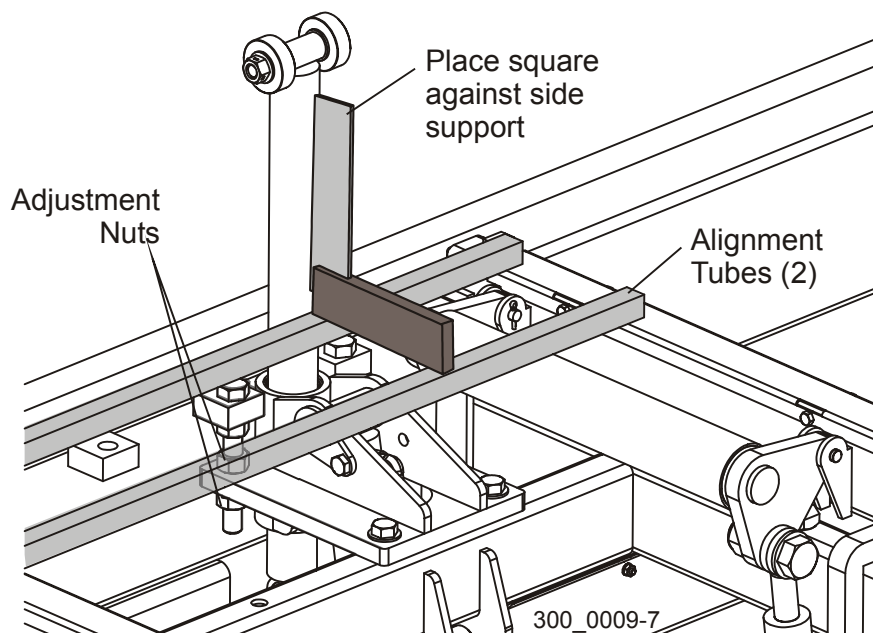

FIG. 7-1

To tilt the side support forward, loosen the top adjustment nuts and tighten the lower adjustment nuts. Adjust both sets of adjustment nuts on each side of the side support evenly. To tilt the side support back, loosen the bottom adjustment nuts and tighten the top adjustment nuts.

7.3 Complete Alignment Procedure

Frame Setup

Before performing the following alignment procedures, setup the mill on firm, level ground.

The stationary sawmill must be setup on perfectly level ground so that the weight of the sawmill is evenly supported by all legs. [See Section 3.1](#)

7 SAWMILL ALIGNMENT

Blade Installation And Tracking

Blade Installation And Tracking

1. Remove the blade and replace the blade wheel belts. New blade wheel belts are required to perform the complete alignment procedure.
2. Blow sawdust off of the blade guide assemblies. Remove sawdust from the blade housings. Scrape any sawdust buildup from the blade wheel rims.
3. Remove the blade guide assemblies and the blade.

NOTE: To remove the blade guide assemblies and maintain the tilt adjustments, only loosen one side screw and the top screw. Leaving the other side screw and bottom screw in position will insure you will return the rollers to their original tilt adjustment.

4. Adjust the outer blade guide arm in or out until the outer blade guide is approximately 24" (61 cm) from the inner blade guide
5. Install a new blade and apply the appropriate tension ([See Section 3.4](#)).
6. Turn the key switch to the "M" position.



7. Manually spin one of the blade wheels until the blade positions itself on the wheels.



DANGER! Always shut off the sawmill motor before replacing the blade. Failure to do so may result in serious injury.



WARNING! Always wear gloves and eye protection when handling bandsaw blades. Changing blades is safest when done by one person! Keep all other persons away from area when coiling, carrying or changing a blade. Failure to do so may result in serious injury.

Blade Wheel Alignment

The blade wheels should be adjusted so they are level in the vertical and horizontal planes. If the blade wheels are tilted up or down, the blade will want to travel in the tilted direction. If the blade wheels are tilted horizontally, the blade will not track properly on the wheels.

1. Use the blade guide alignment tool to check the vertical alignment of each blade wheel. Attach the tool to the blade near the inner blade guide mount. Be sure the tool does not rest on a tooth or burr, and is lying flat on the blade.

See Figure 7-11.

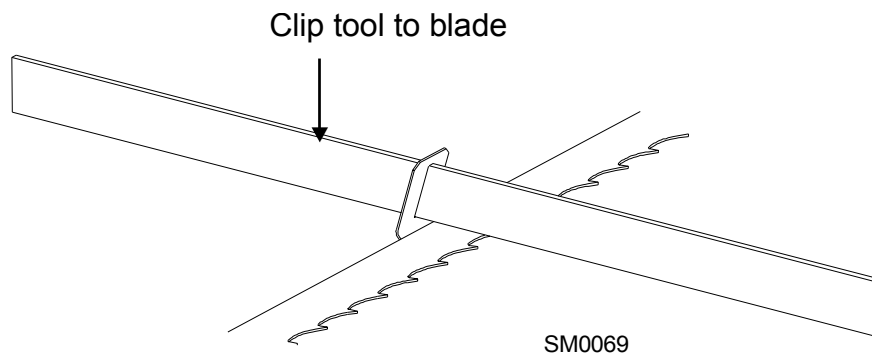

FIG. 7-11

2. Move the saw carriage so the front end of the tool is positioned over the first bed rail. Measure from the bottom of the tool to the top surface of the bed rail.
3. Move the saw carriage so the rear of the tool is positioned over the bed rail. Again, measure from the bottom of the tool to the bed rail.
4. If the two measurements are not equal $\pm 1/16"$ (1.5 mm), adjust the vertical tilt of the drive-side blade wheel.

See Figure 7-12. Use the vertical adjustment screws to adjust the drive-side blade wheel. To tilt the wheel down, loosen the top adjustment screw one quarter turn. Loosen the jam nut on the bottom adjustment screw and tighten the screw. Tighten the top and bottom jam nuts.

See Figure 7-13.

To tilt the wheel up, loosen the bottom adjustment screw one quarter turn. Loosen the jam nut on the top adjustment screw and tighten the screw. Tighten the top and bottom jam nuts.

7 SAWMILL ALIGNMENT

Blade Wheel Alignment

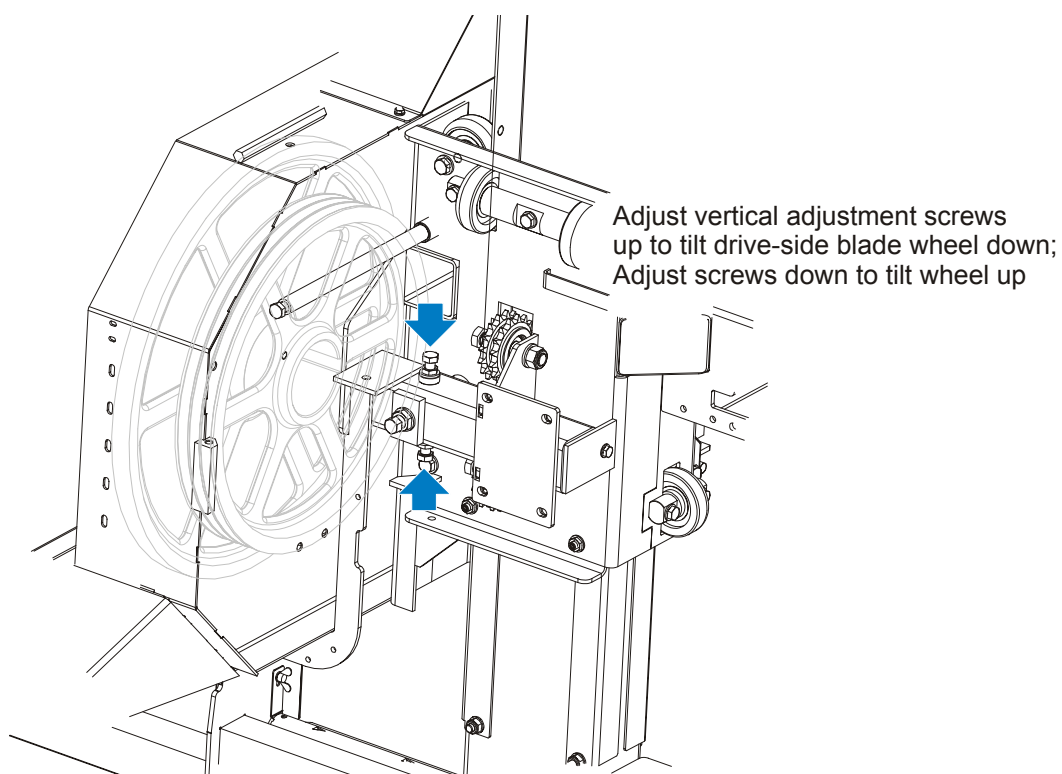

FIG. 7-13

5. Recheck the vertical tilt of the drive-side blade wheel with the blade guide alignment tool. Readjust the blade wheel as necessary until the front and rear of the tool are the same distance from the bed rail (within 1/16" [1.5 mm]).
6. Remove the tool from the blade and reattach it near the outer blade guide assembly.
7. Measure from the tool to the bed rail at both ends of the tool. If the measurements at the front and rear ends of the tool are not equal $\pm 1/16"$ (1.5 mm), adjust the vertical tilt of the idle-side blade wheel.

See Figure 7-14. Use the vertical adjustment screws to adjust the idle-side blade wheel. To tilt the wheel up, loosen the bottom adjustment screw one quarter turn. Loosen the jam nut on the top adjustment screw and tighten the screw. Tighten the top and bottom jam nuts.

To tilt the wheel down, loosen the top adjustment screw one quarter turn. Loosen the jam nut on the bottom adjustment screw and tighten the screw. Tighten the top and bottom jam nuts.

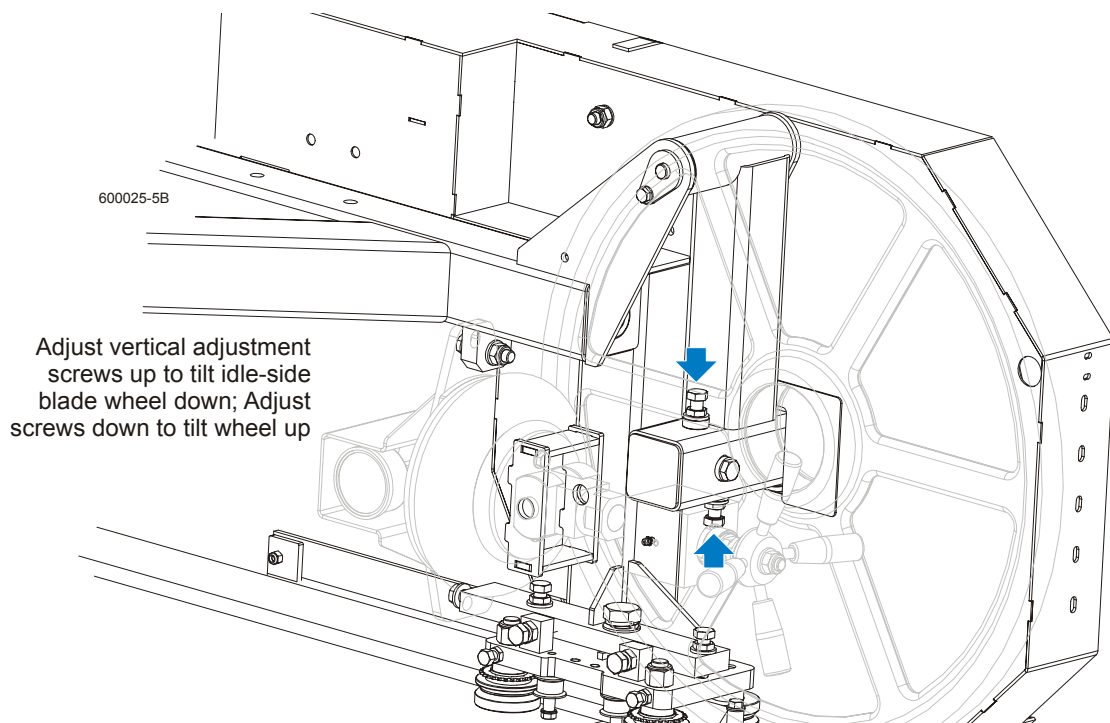

FIG. 7-14

8. Recheck the vertical tilt of the idle-side blade wheel with the blade guide alignment tool. Readjust the blade wheel as necessary until the front and rear of the tool are the same distance from the bed rail (within 1/16" [1.5 mm]).

7 SAWMILL ALIGNMENT

Blade Wheel Alignment

9. Check the position of the blade on the idle-side blade wheel.

See Figure 7-15. The horizontal tilt of the blade wheel should be adjusted so that the gullet of a 1-1/4" blade is 1/8" (3 mm) out from the front edge of the wheel ($\pm 1/16"$ [1,5 mm]). The gullet of a 1-1/2" blade should be 3/16" (4.5 mm) out from the front edge of the wheel ($\pm 1/16"$ [1,5 mm]). Do not let the teeth ride on the wheels.

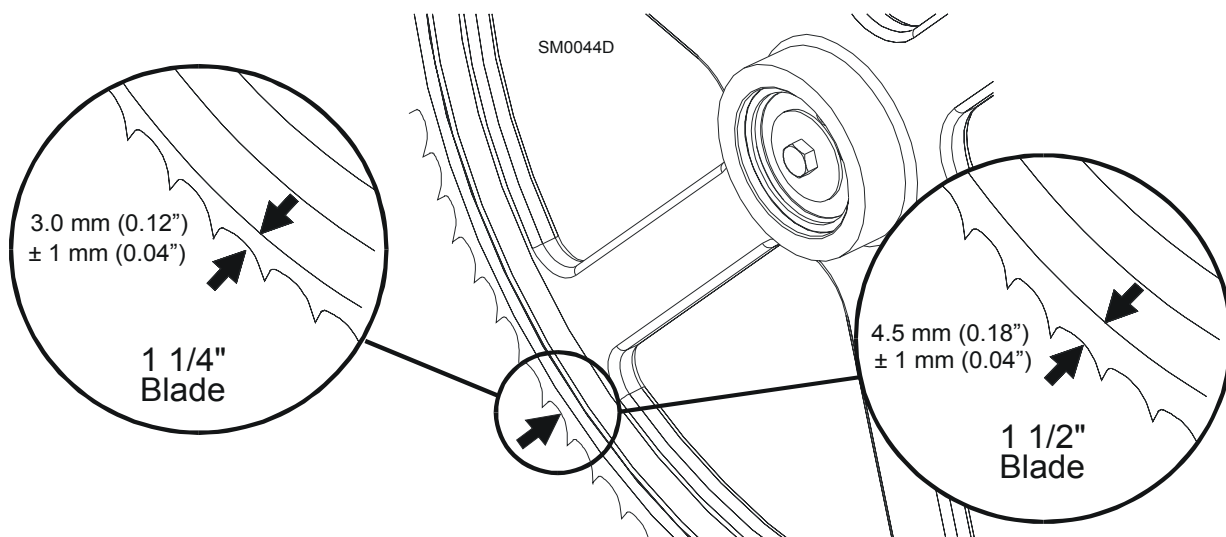

FIG. 7-15

See Figure 7-16. Use the cant control adjustment to adjust the idle-side blade wheel. If the blade is too far forward on the wheel, turn the cant control counterclockwise. If it is too far back on the wheel, turn the cant control clockwise.

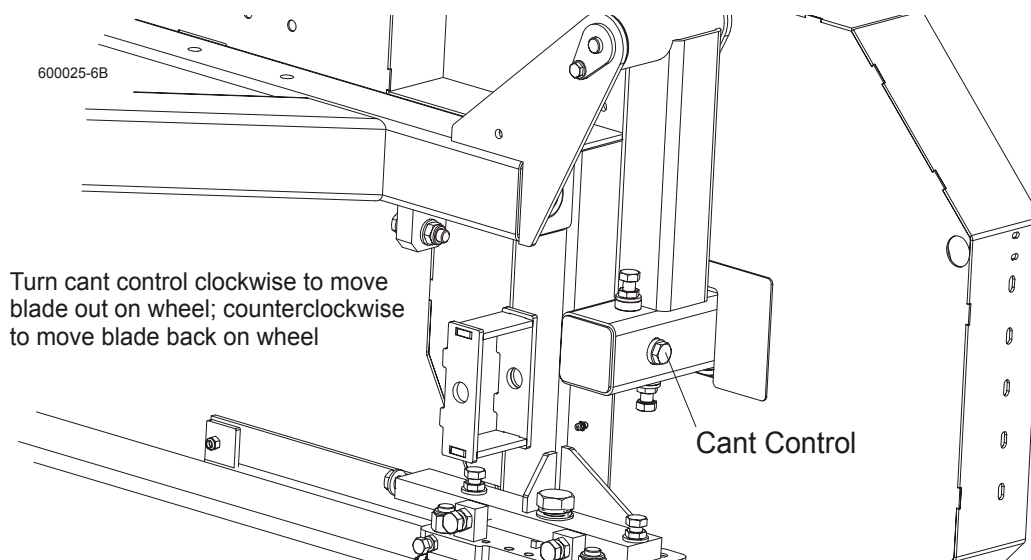
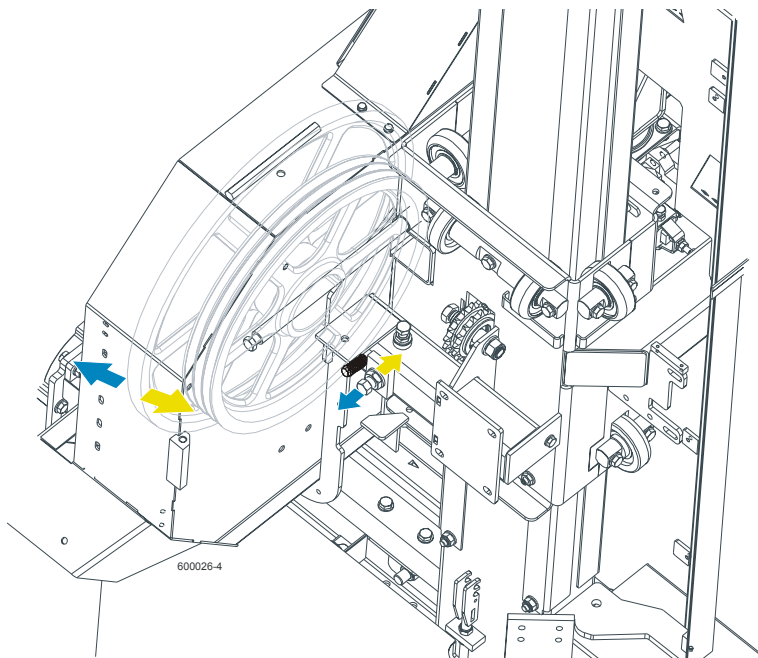

FIG. 7-16

10. Check the position of the blade on the drive-side blade wheel. The blade should be positioned on the wheel as described for the idle-side blade wheel. Adjust the drive-side blade wheel if necessary.

See Figure 7-17. Use the horizontal adjustment screw to adjust the drive-side blade wheel. To move the blade back on the wheel, loosen the jam nut on the adjustment screw and tighten the screw. Tighten the jam nut.

To move the blade out on the wheel, loosen the jam nut on the adjustment screw and loosen the screw. Tighten the jam nut.



Loosen adjustment bolt to move blade out on wheel; Tighten adjustment bolt to move blade in on wheel

FIG. 7-17

7 SAWMILL ALIGNMENT

Blade Wheel Alignment

See Figure 7-18. To adjust the saw head tilt, use the bolts located at the bottom of the saw head mast. Loosen the three sets of four retaining plate bolts. To raise the outside of the saw head, back the stop bolts out, then tighten the adjustment bolts. To lower the outside of the saw head, loosen the adjustment bolts and tighten the stop bolts. Recheck the saw head tilt and readjust the bolts as necessary. Retighten the retaining plate bolts.

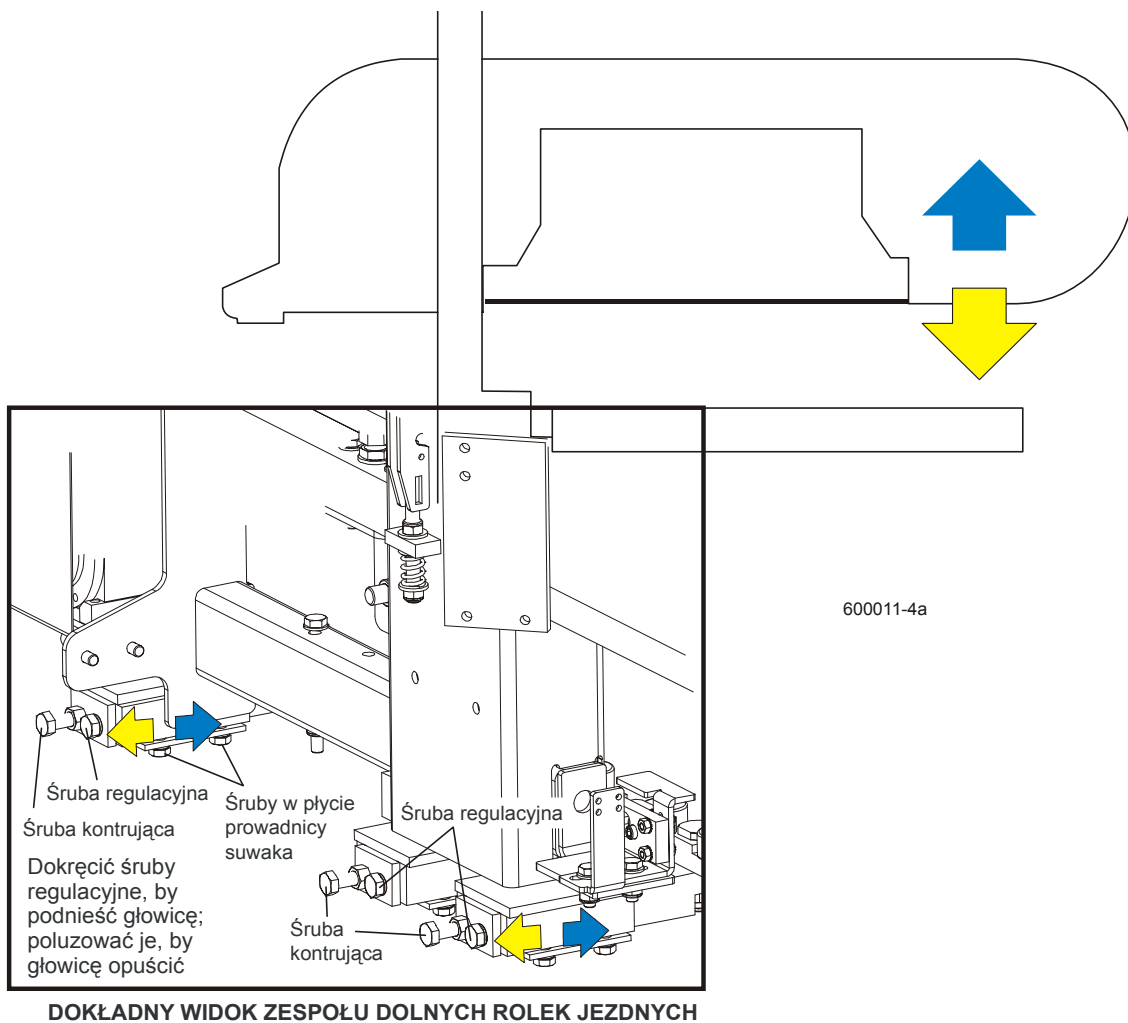

FIG. 7-18

See Figure 7-19. Loosen the bed rail clamping bolts and turn the adjustment bolts to move the bed rails to the blade if necessary. Retighten the clamping bolts and adjustment bolt jam nuts.

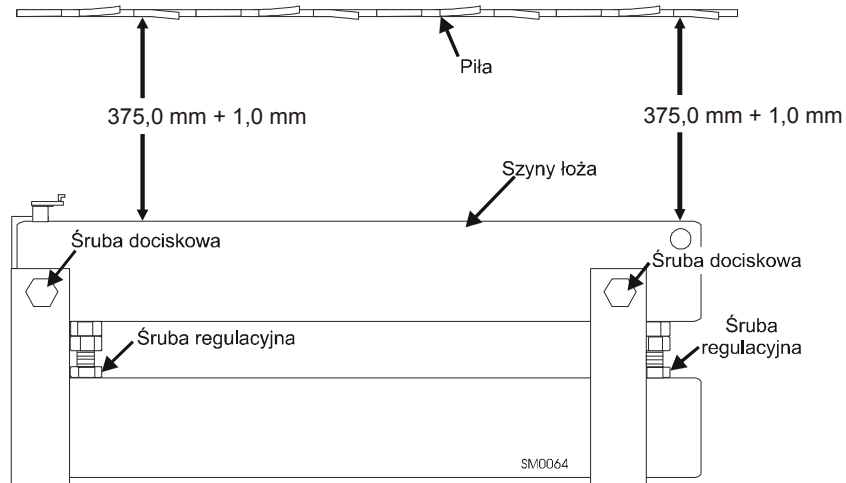

FIG. 7-19

11. Without adjusting the saw head height, check the three remaining main bed rails and the rear pivot rail. Adjust them so that all measure the same distance from the blade at both ends of the bed rail.

7 SAWMILL ALIGNMENT

Blade Guide Installation

Blade Guide Installation

Each Wood-Mizer sawmill has two blade guide assemblies that help the blade maintain a straight cut. The two blade guide assemblies are positioned on the saw head to guide the blade on each side of the material being cut.

One blade guide assembly is mounted in a stationary position on the drive side of the saw head. This assembly is referred to as the "inner" blade guide assembly.

The other blade guide assembly is mounted on the idle side of the saw head. It is referred to as the "outer" assembly and is adjustable for various widths of materials to be processed.

NOTE: Before installing the blade guide assemblies, remove the blade guide adjusting screws and apply a lubricating oil meeting the SAE viscosity standard (e.g. 10W30 or Dexron III) to each screw. This will prevent the screws and threaded holes from corroding and make screw adjustments easier.

1. Inspect the guide disks and repair or replace as necessary. Remove the blade from the sawmill.

See Figure 7-20.

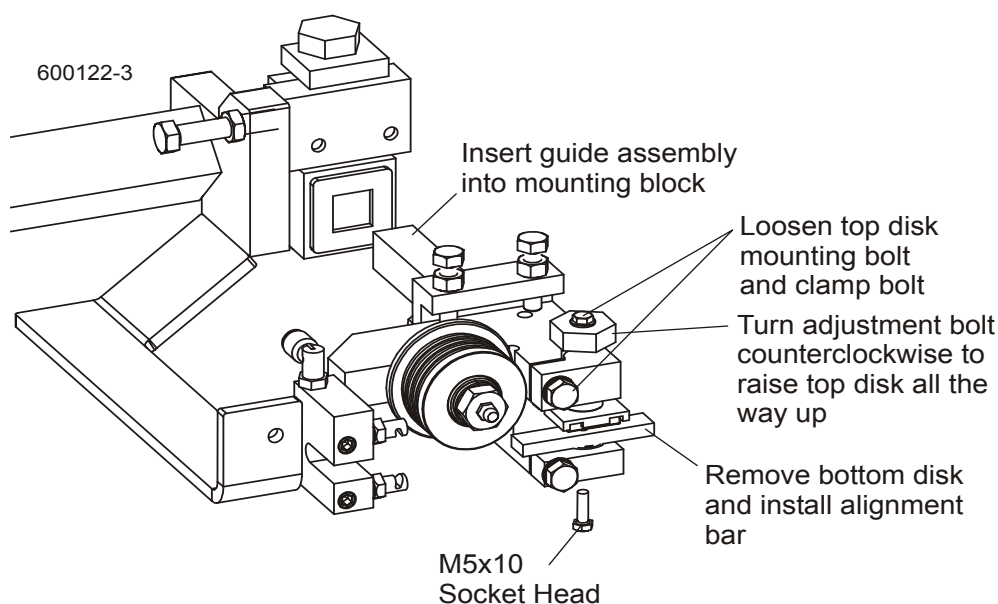

FIG. 7-20

2. Loosen the top disk clamp bolt and mounting bolt. Turn the adjustment bolt

counterclockwise to raise the top disk all the way up. Remove the bottom guide disk from each blade guide assembly and install the provided alignment bar.

3. Install each blade guide assembly to the mounting blocks and push all the way back. Install, tension and track the blade. Adjust the outer blade guide assembly so the roller flange is 1/8" (3 mm) from the blade. Adjust the inner blade guide assembly so the roller flange is 1/16" (1.5 mm) from the blade.

7 SAWMILL ALIGNMENT

Blade Guide Installation

See Figure 7-21.

Tighten the two previously-loosened tilt adjustment screws to secure the blade guide assembly. Turn the top adjustment bolt clockwise to raise the blade guide assembly so it does not touch the blade.

With the roller flange positioned properly from the back of the blade, adjust the rear bolt so it touches the end of the blade guide mounting shaft.

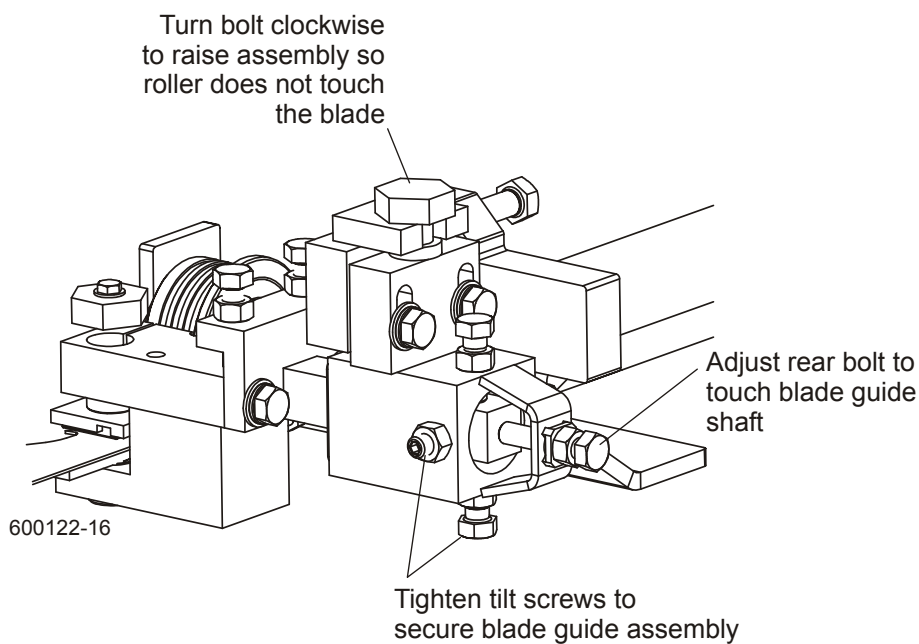

FIG. 7-21

Blade Guide Arm Alignment

The blade guide arm moves the outer blade guide in and out. If the arm becomes loose, the blade guide will not deflect the blade properly, causing inaccurate cuts. A loose blade guide arm can also cause blade vibration.

1. Adjust the blade guide arm in to 1/2" (15 mm) from fully closed.
2. Manually try to move the arm up or down. If you can move the arm by hand, you will need to tighten the arm rollers.

See Figure 7-22. Loosen the jam nuts and turn the adjustment bolts in to tighten the

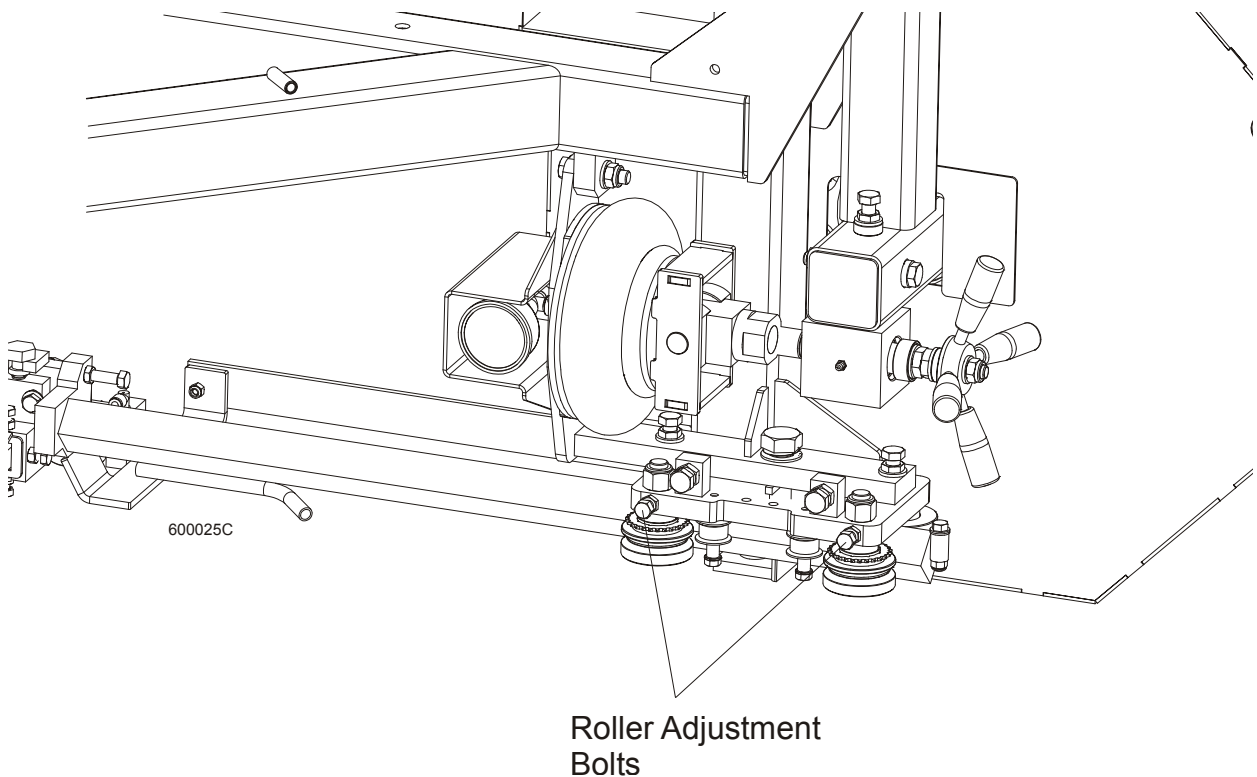

FIG. 7-22

blade guide arm rollers. Retighten the jam nuts.

7 SAWMILL ALIGNMENT

Blade Guide Arm Alignment

After tightening the blade guide arm rollers, check that the arm is aligned properly.

3. With the arm adjusted 1/2" (15 mm) from fully closed, measure the distance between the blade guide roller and the blade.

See Figure 7-23.

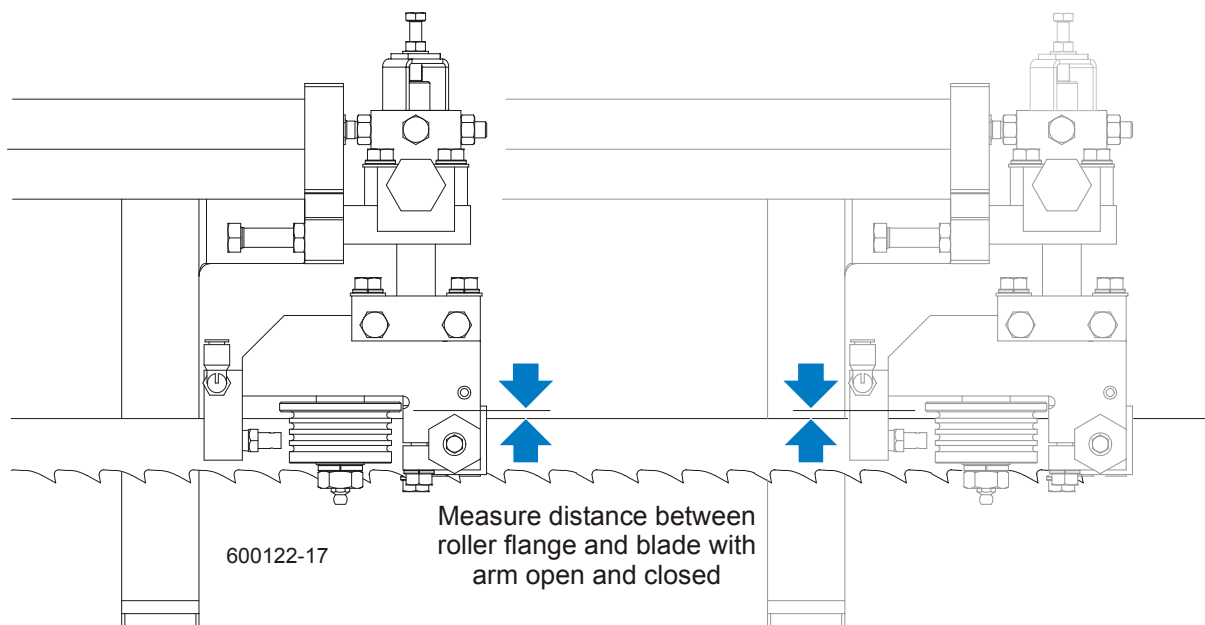

FIG. 7-23

4. Adjust the blade guide arm to 1/2" (15 mm) from fully open and remeasure the distance from the blade guide roller to the back of the blade. The two measurements should be the same. If not, adjust the horizontal tilt of the blade guide arm.

See Figure 7-24. Loosen the horizontal adjustment bolt jam nuts. To tilt the arm in toward the blade, loosen the right bolt and tighten the left bolt. To tilt the arm out away from the blade, loosen the left bolt and tighten the right bolt. Retighten the jam nuts and recheck the blade guide arm horizontal tilt.

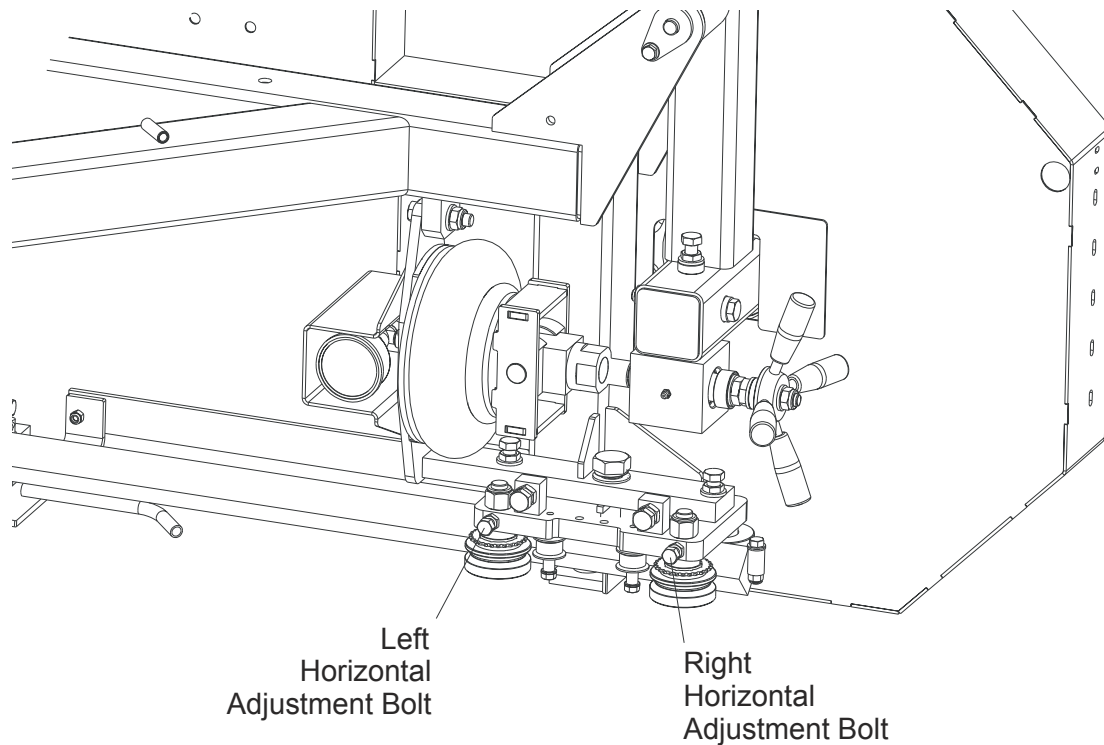

FIG. 7-24

5. Now check the vertical tilt of the blade guide arm. Move the saw carriage so the blade guide arm is positioned over a bed rail.
6. With the arm adjusted 1/2" (15 mm) from fully closed, raise or lower the saw head until the bottom of the blade guide mounting block is 15" (375 mm) from the top of the bed rail.

7 SAWMILL ALIGNMENT

Blade Guide Arm Alignment

See Figure 7-25. Adjust the blade guide arm to 1/2" (15 mm) from fully open. Remeasure the distance from the blade guide mounting block to the bed rail. This measurement should be 15" (375 mm) or slightly higher because the saw head is tilted up 1/16" (1.5 mm) on the outside ([Patrz Saw Head Tilt](#)). If the measurements are not the same, adjust the blade guide arm vertically.

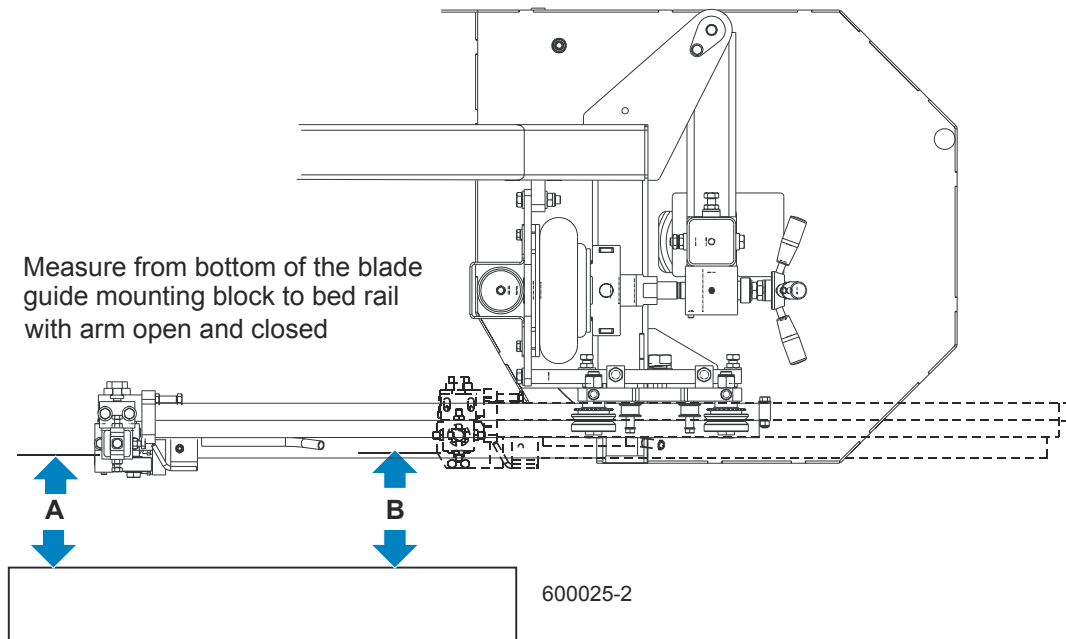

FIG. 7-25

See Figure 7-26. Loosen the vertical adjustment bolt jam nuts. To tilt the blade guide arm down, loosen the right bolt and tighten the left bolt. To tilt the blade guide arm up, loosen the left bolt and tighten the right bolt. Retighten the jam nuts and recheck the blade guide arm vertical tilt.

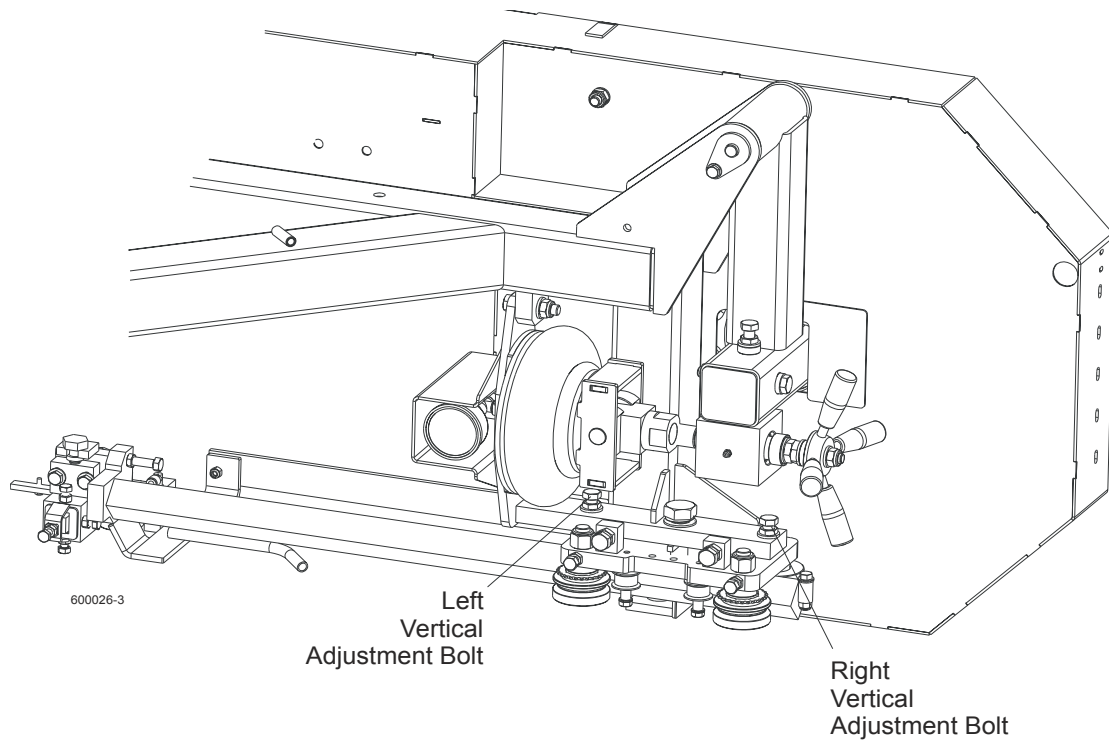

FIG. 7-26

7 SAWMILL ALIGNMENT

Blade Deflection

Blade Deflection

Perform the following steps to achieve proper blade deflection with the blade guides.

1. Raise the carriage until the blade is 15" (375 mm) above a bed rail. Measure the distance from the top of the rail to the bottom of the blade.

See Figure 7-27. Loosen the clamp bolts. Turn the top adjustment bolt counterclockwise to lower the blade guide assembly so the blade guide deflects the blade down and the bottom of the blade measures 14 3/4" (370 mm) from the bed rail. Tighten the clamp

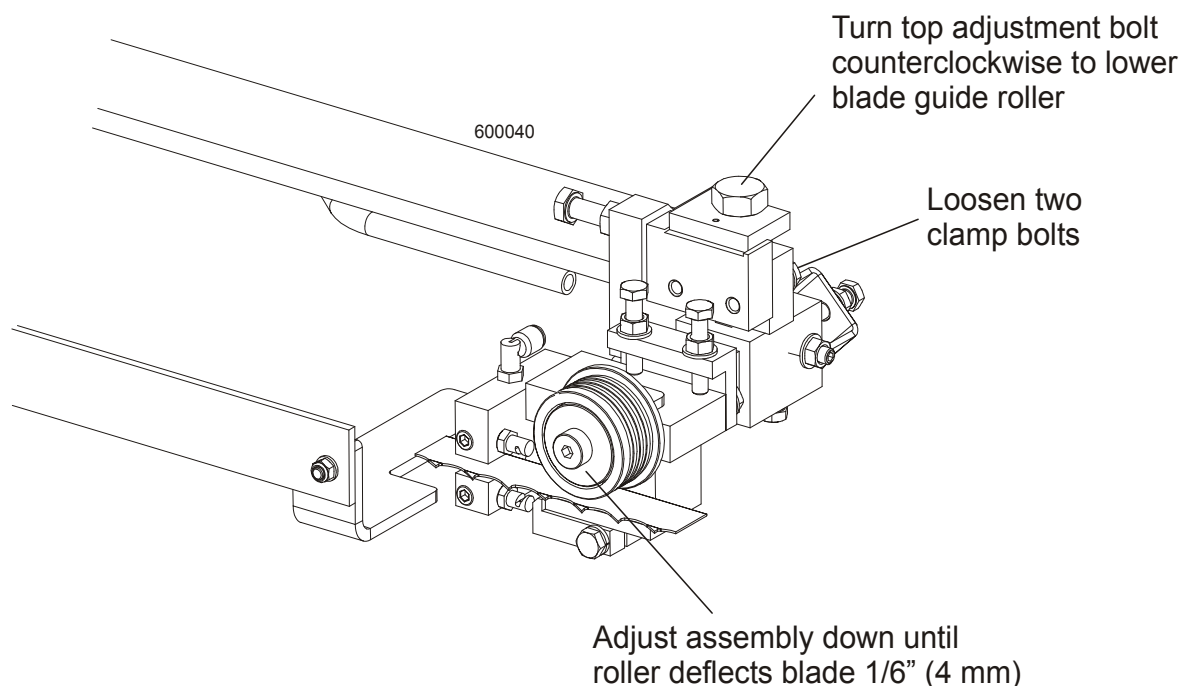

FIG. 7-27

bolts.

2. Repeat for the other blade guide.

Blade Guide Vertical Tilt Adjustment

The blade guides should be adjusted properly in the vertical plane so that the blade is parallel to the sawmill bed. A Blade Guide Alignment Tool (BGAT) is provided to help you measure the vertical tilt of the blade.

1. Open the adjustable blade guide arm 1/2" (15 mm) from full open.
2. Clip the alignment tool on the blade. Position the tool close to the outer blade guide. Be sure the tool does not rest on a tooth or burr, and is lying flat on the blade.

See Figure 7-28.

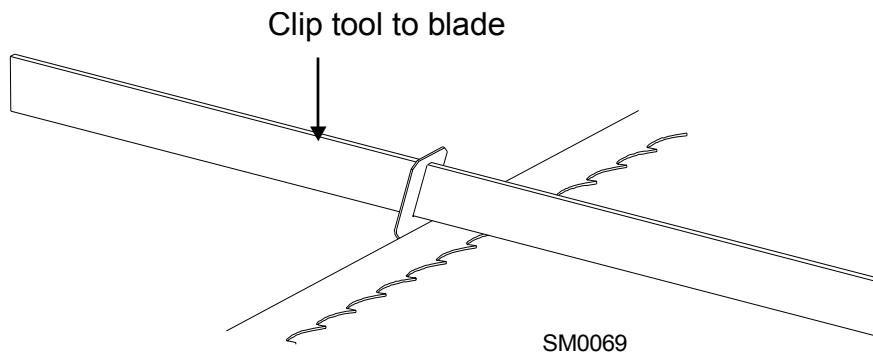

FIG. 7-28

3. Move the carriage so that the front end of the tool is positioned above the bed rail. Measure the distance from the bed rail to the bottom edge of the tool.
4. Move the carriage so that the back end of the tool is positioned above the bed rail. Measure the distance from the bed rail to the bottom edge of the tool.
5. If the measurement from the tool to the bed rail is not equal within 1/32" (.75 mm), adjust the vertical tilt of the outer blade guide roller.

7 SAWMILL ALIGNMENT

Blade Guide Vertical Tilt Adjustment

See **Figure 7-29**. Loosen the jam nuts on the top and bottom vertical tilt adjustment screws. To tilt the roller up, loosen the bottom screw and tighten top screw. To tilt the roller down, loosen the top screw and tighten the bottom screw. Tighten the jam nuts and recheck the tilt of the blade.

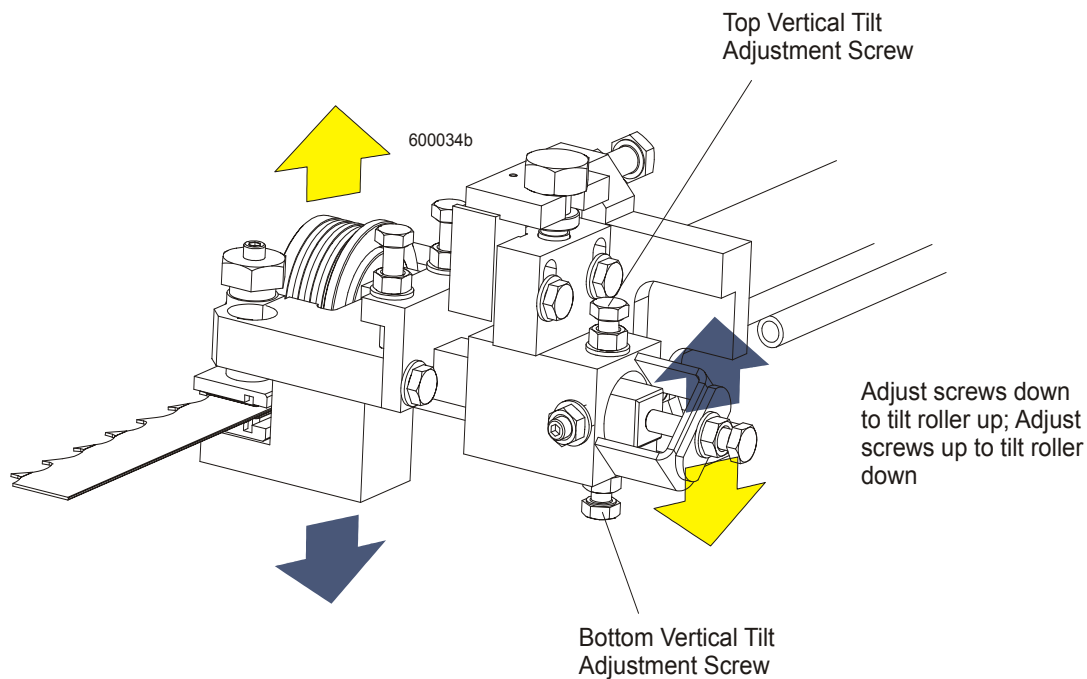

FIG. 7-29

6. Move the blade guide alignment tool close to the inner blade guide assembly and repeat the above steps. Adjust the vertical tilt of the inner blade guide if necessary.

Blade Guide Horizontal Tilt Adjustment

If the blade guides are tilted in the wrong direction horizontally, the back of the blade may contact the flange as the roller is spinning down, causing it to push the blade away from the guide roller. This may result in premature blade cracking.

1. Remove the blade guide alignment tool from the blade and adjust the blade guide arm halfway in.
2. Remove the clip from the blade guide alignment tool. Place the tool against the face of the outer blade guide roller.

See Figure 7-30.

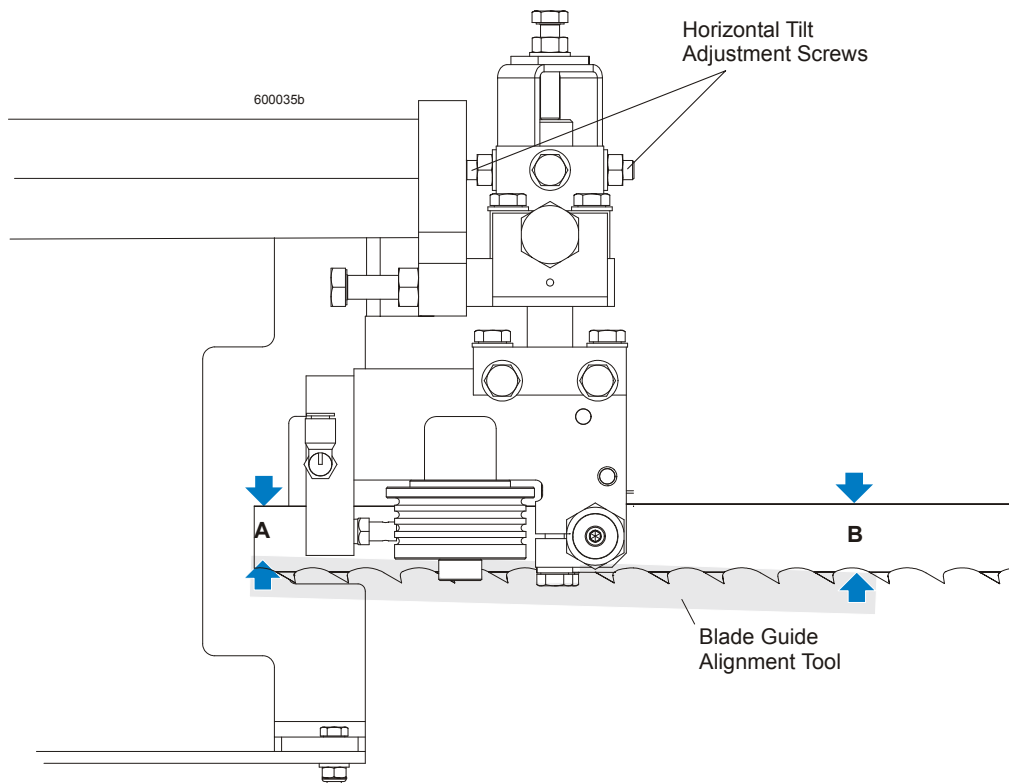

FIG. 7-30

3. Measure between the back edge of the blade and the tool at the end closest to the inner blade guide ("B").
4. Measure between the back edge of the blade and the other end of the tool ("A").

The blade guide roller should be tilted slightly to the left ('A' 1/8" [3 mm] less than 'B').

7 SAWMILL ALIGNMENT

Blade Guide Horizontal Tilt Adjustment

See Figure 7-31. Loosen the jam nuts on the horizontal tilt adjustment screws. To tilt the roller left, loosen the right screw and tighten left screw. To tilt the roller right, loosen the left screw and tighten the right screw. Tighten the jam nuts and recheck the tilt of the blade.

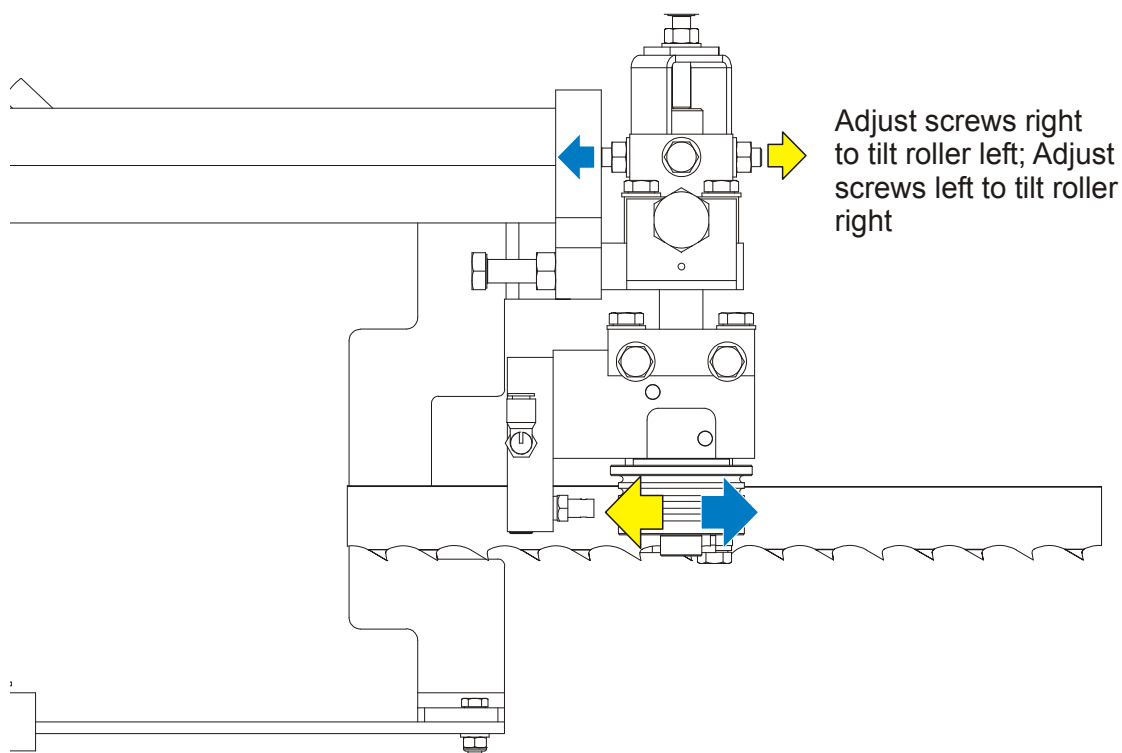

FIG. 7-31

5. Repeat the above steps for the inner blade guide roller assembly.

NOTE: Once the blade guides have been adjusted, any cutting variances are most likely caused by the blade. *Patrz Podręcznik obsługi Piły, Form #600.*

Blade Guide Flange Spacing

Each blade guide must be adjusted so the roller flange is the correct distance from the back edge of the blade. If the flange is too close to or too far from the blade, the sawmill will not cut accurately.

HINT: When adjusting blade guide spacing, loosen the top set screw and one side set screw only. This will ensure horizontal and vertical tilt adjustments are maintained when the adjustment screws are retightened.

1. Measure the distance between the flange on the inner blade guide roller to the back edge of the blade. This distance should measure 1/16" (1.5 mm). Adjust the roller back or forward if necessary.

See Figure 7-32. Loosen the top and one side set screw as well as the rear adjustment bolt if necessary. Tap the blade guide forward or backward until properly positioned.

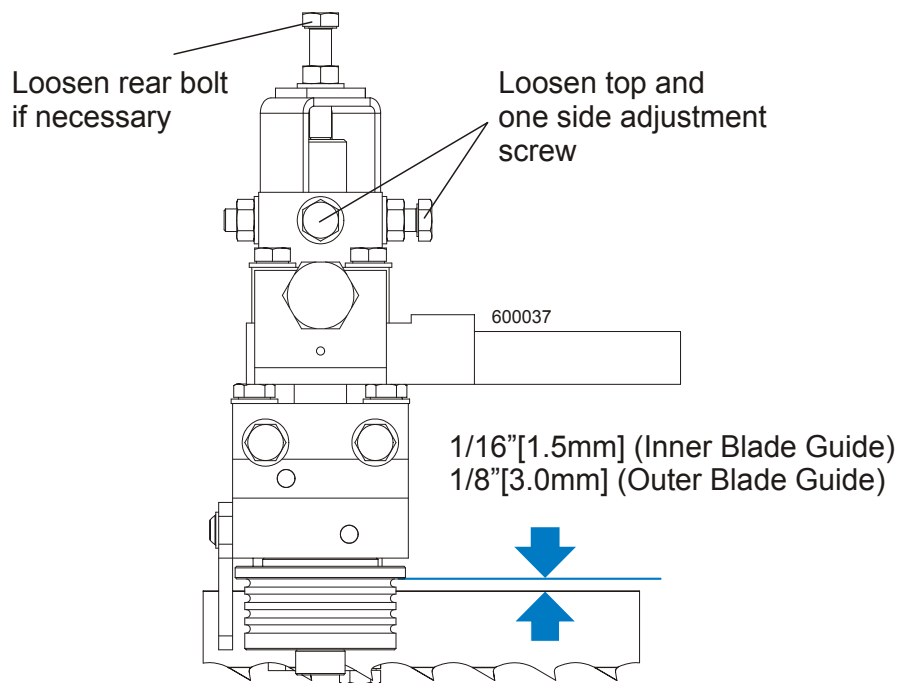

FIG. 7-32

Retighten the screws and jam nuts.

2. Measure the distance between the flange on the outer blade guide roller to the back edge of the blade. This distance should measure 1/8" (3.0 mm). Adjust the roller back or forward if necessary.

7 SAWMILL ALIGNMENT

Blade Guide Levelling

Blade Guide Levelling

Perform the following steps to make sure the blade guide assembly is parallel to the blade.

1. Loosen the alignment bar mounting bolt. Use the provided adjustment tool to adjust the alignment bar up so the bar is close to, but not touching the bottom of the blade. Retighten the alignment bar mounting bolt.
2. Check that the gap from the alignment bar to the blade is the same along entire length of the bar. Shine a flashlight behind the blade guide assembly to help you see the gap between the bar and the blade. To adjust, loosen the rear clamp bolts, but leave snug. Determine which of the two adjustment bolts to use to tilt the blade guide assembly as desired. Loosen the jam nut and turn the bolt until the alignment bar is parallel to the blade. Retighten the jam nut and clamp bolts. Repeat for the second blade guide assembly.

See Figure 7-33.

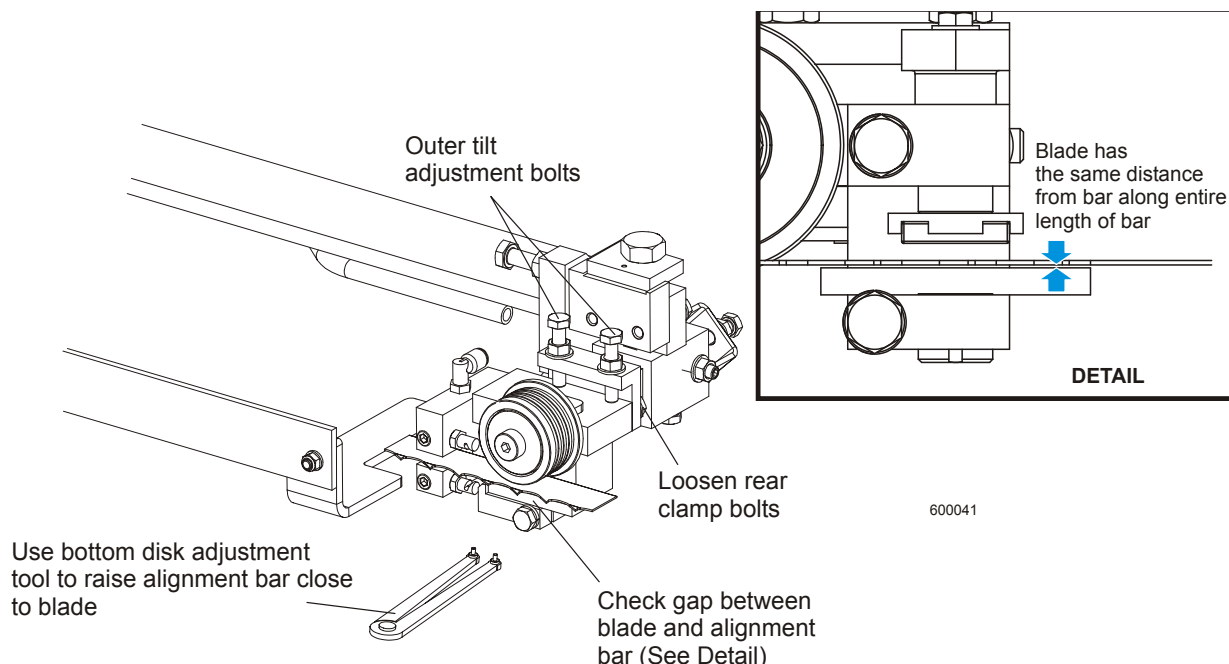

FIG. 7-33

Guide Disk Adjustment

1. Remove the blade and the alignment bars from the blade guide assemblies. Install new or reconditioned bottom guide disks to both blade guide assemblies (leave mounting bolts loose). Use the provided bottom disk adjustment tool to lower the bottom disk all the way down. Install, tension and track the blade.

See Figure 7-34.

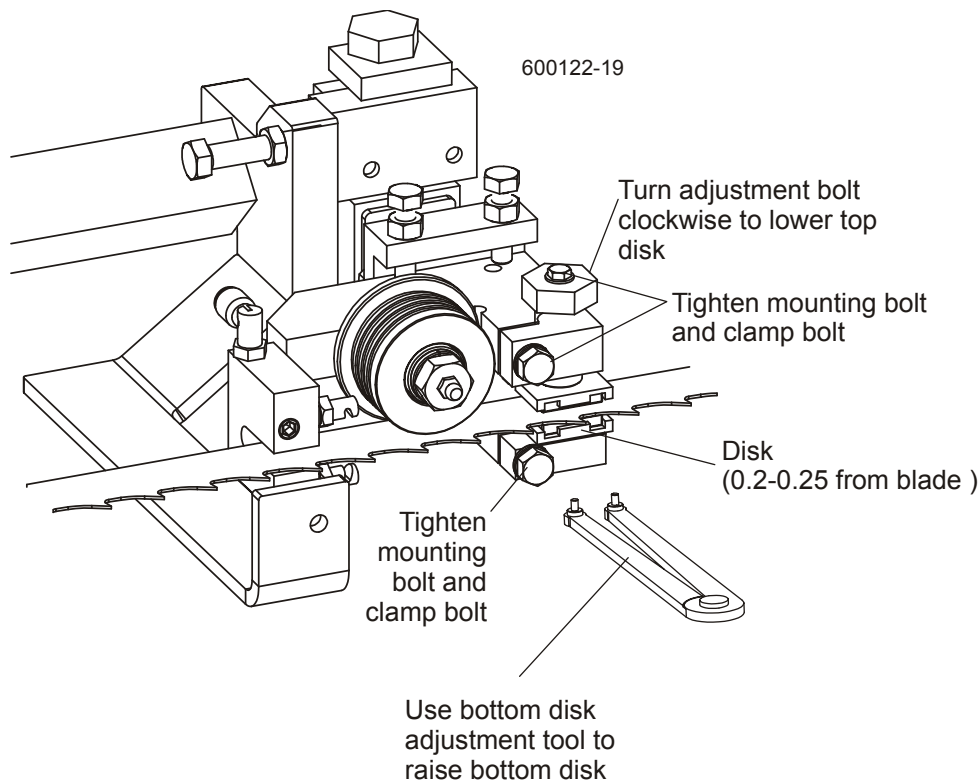

FIG. 7-34

2. Use the bottom disk adjustment tool to raise the bottom disk to .008" - .010" (.2-.25 mm) from the blade. Tighten the bottom disk mounting bolt and clamp bolt.
3. Turn the top disk adjustment bolt clockwise to lower the top disk to .008" - .010" (0.2 - 0.25 mm) from the blade. Tighten the top disk mounting bolt and clamp bolt.
4. After tightening the clamp bolt, recheck the distance from the top disk to the blade and readjust if necessary.

7 SAWMILL ALIGNMENT

Align Side Supports

7.3.35 Align Side Supports

See Figure 7-2. Place two square tubes or straight board across the bed rails in front of one of the side supports. Use the controls to raise the side supports all the way up. Set a square on the tubes or board and place against the side support. The side support should be square to the bed or tilted slightly forward $1/32''$ (0.8 mm). Adjust the tilt of the side support if necessary.

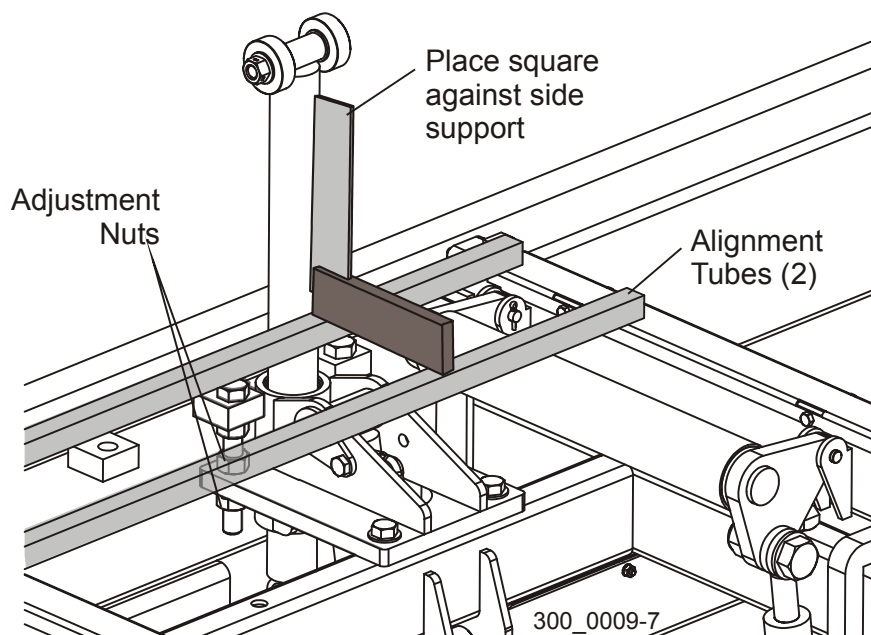

FIG. 7-2

To tilt the side support forward, loosen the top adjustment nuts and tighten the lower adjustment nuts. Adjust both sets of adjustment nuts on each side of the side support evenly. To tilt the side support back, loosen the bottom adjustment nuts and tighten the top adjustment nuts.

Main Clamp Stop Adjustment

1. Once the side supports are aligned, lower them down.
2. Tie a string to the stop block at the first bed rail. Stretch the string toward the rear of the frame and tie to the stop block at the last bed rail.

See Figure 7-36. Loosen the clamp stop bolts and adjust the clamp stop until it touches the string .

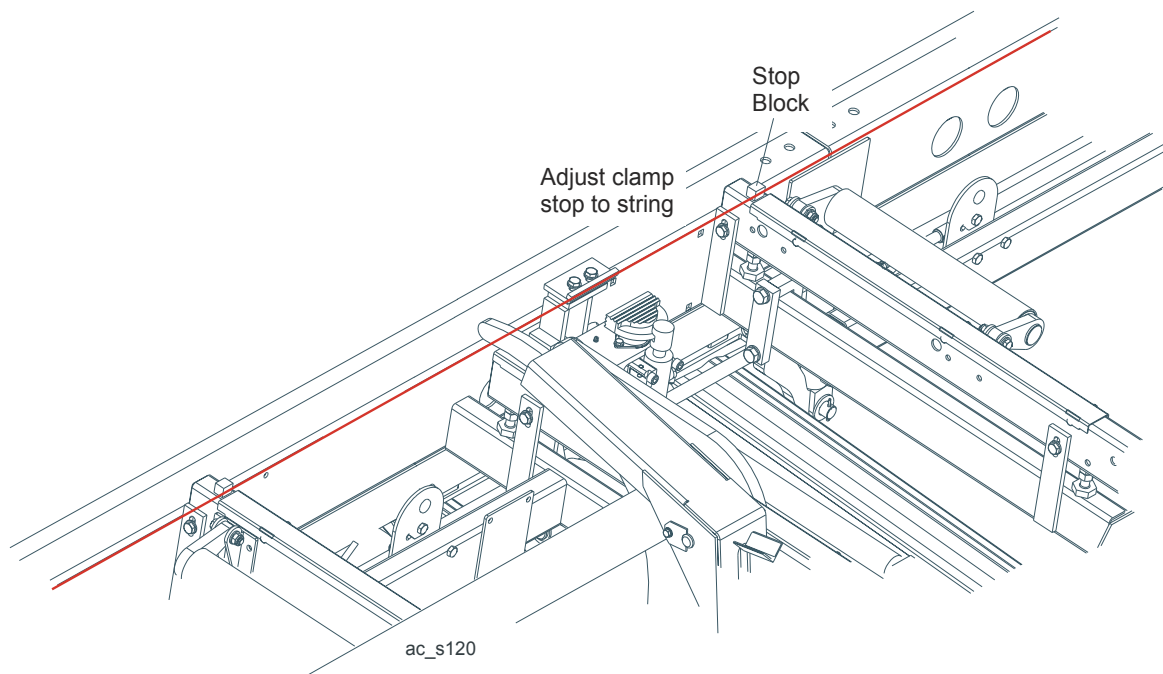

FIG. 7-36

7 SAWMILL ALIGNMENT

Saw Head Tilt

Saw Head Tilt

As the blade enters a wide log or cant, the outside of the saw head will drop down slightly. To compensate for the drop, the saw head is adjusted 1/16" (1.5 mm) higher at the outside.

1. Move the saw carriage so the blade is positioned over a bed rail. Adjust the blade guide arm to 1/2" (15 mm) from full open.
2. Raise the saw head so the bottom of the blade measures 14 3/4" (375 mm) from the top surface of the bed rail near the inner blade guide assembly.

See Figure 7-37.

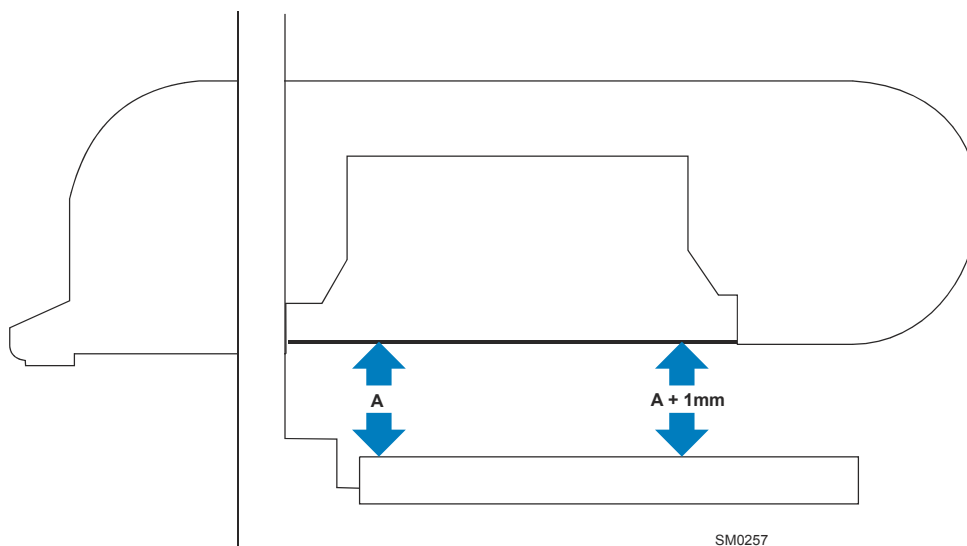
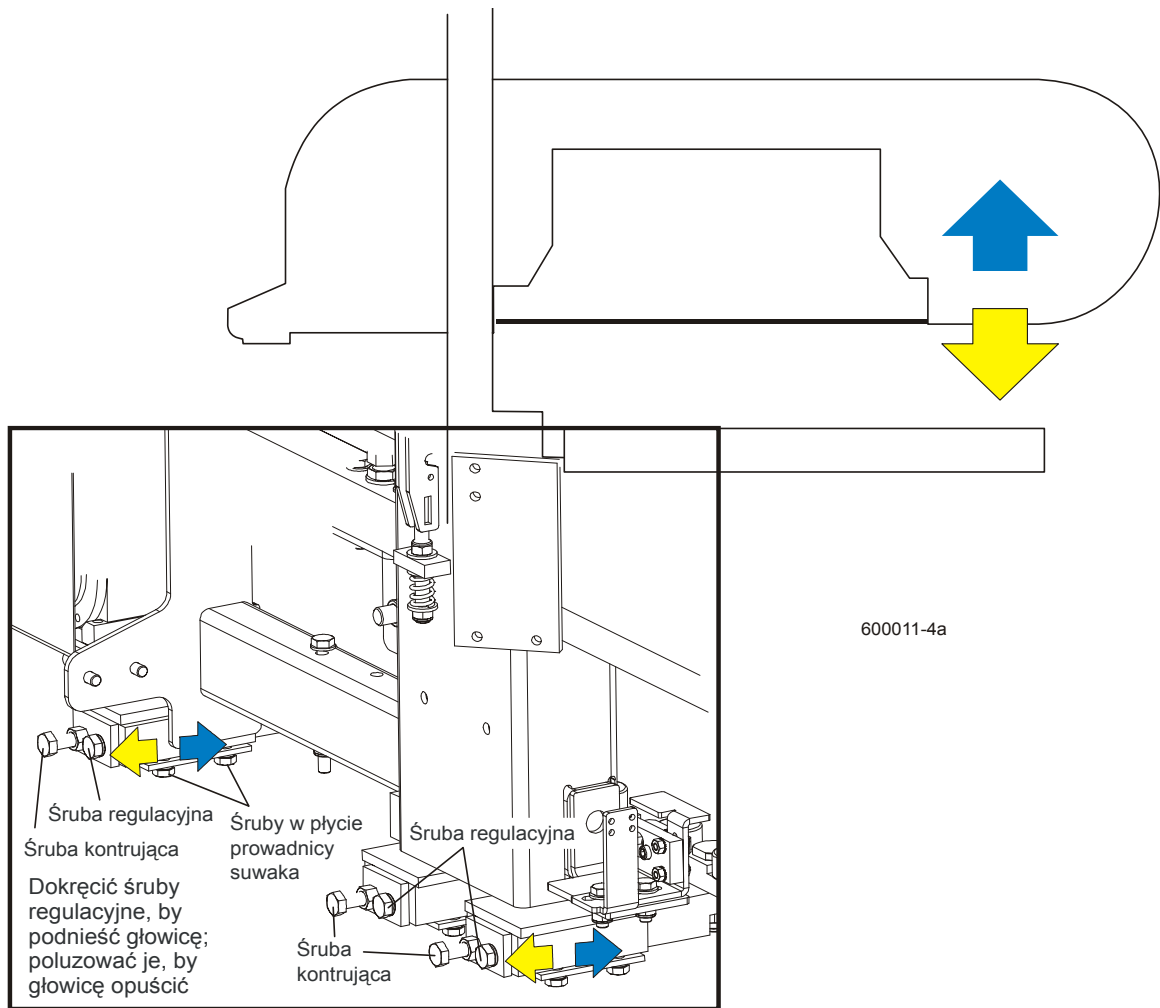

FIG. 7-37

3. Measure from the bottom of the blade to the top surface of the bed rail near the outer blade guide assembly. This measurement should be 1/16" (1.5 mm) higher than the inner measurement, i.e., it should be 376.5 mm.

See Figure 7-38. To adjust the saw head tilt, use the bolts located at the bottom of the mast. Loosen the three sets of four retaining plate bolts. To raise the outside of the saw head, back the stop bolts out, then tighten the adjustment bolts. To lower the outside of the saw head, loosen the adjustment bolts and tighten the stop bolts. Then recheck the measurement from the blade to the bed rails near the outer blade guide. Adjust the stop bolts and adjustment bolts as necessary, until the outside of the saw head is 1/16"

(1.5 mm) higher than the inside. Retighten the retaining plate bolts.



DOKŁADNY WIDOK ZESPOŁU DOLNYCH ROLEK JEZDNYCH

FIG. 7-38

SECTION 8 SPECIFICATIONS

8.1 Log Capacity

See Table 8-1. The log size capacities of the LT70 Remote sawmill are listed below.

	LT70 Remote
Maximum Log Diameter	93 cm
Maximum Log Length	6.7 m
Maximum Log Weight	3000kg

TABLE 8-1

8.2 Overall Dimensions

See Table 8-2. The overall dimensions of the LT70 Remote sawmill are listed below.

	LT70 Remote
Length	10 m
Width	2.4 m
Height	2.5 m

TABLE 8-2

8.3 Motor Specifications

See Table 8-3. Below are the specifications of the blade motor.

Motor Type	Manufacturer	Model No.	Power	Other Specifications
25HP Electric Motor ¹	Indukta SA, Poland	Sg 160L-2	18.5kW	33.8 A, 2930 r.p.m.

TABLE 8-3

¹The electric motors supplied on Wood-Mizer sawmills carry a rating assigned by the motor manufacturer for the continuous duty operation of the motor, potentially, 24 hours per day, day after day.

See Table 8-4. The table below contains specifications of the remaining electric motors used in LT60HD/70HD/80HD sawmills.

Motor Type	Manufacturer	Voltage	Power	WM Part #
Power Feed Motor	Besel, Polska	3 x 400V	1.1 kW, 1380 r.p.m.	086530
Up/Down Motor	Besel, Polska	3 x 400V	1.1 kW, 1380 r.p.m.	086530
Blade Guide Arm Motor	Motor Products Owosso, USA	12V	60 r.p.m.-17W	P09698-1
Hydraulic Pump Motor (AC)	Tamel, Tarnów Poland	400V	1290 r.p.m.-4kW	086789

TABLE 8-4

See Table 8-5. The level of noise produced by Wood-Mizer sawmills is specified below.

Sawmill Equipped With Electric Motor	81.4 dB (A)
--------------------------------------	-------------

TABLE 8-5

8.4 Chains

See Table 8-6. The load capacities of the chains are listed below.

	Load Capacity According To ISO Nr 08A-1
Power Feed Chain	22700N
Up/Down Chain	45400N

TABLE 8-6

8.5 Hydraulic System

See Table 8-7. The specifications of the hydraulic system are given below.

Hydraulic Pump	#200748290750AP100/10-S409 Hydroirma (AC)
Pressure Rating	16 MPa (2320 PSI) (AC)
Maximum Pressure	20MPa (2900 PSI) (AC)

TABLE 8-7

8.6 Belt Sizes

See Table 8-8. Belt sizes for LT70 Series sawmills are shown below.

Description	Belt Size	Wood-Mizer Part #
Drive Belt (E25)	3B/HB 2462La	089464
Up/Down Drive Belt	HA560	090558
Blade Wheel Belt	B72.5 ¹	017922

TABLE 8-8

¹To insure proper blade tracking, use Goodyear, Dayco Super II, or Browning belts only.

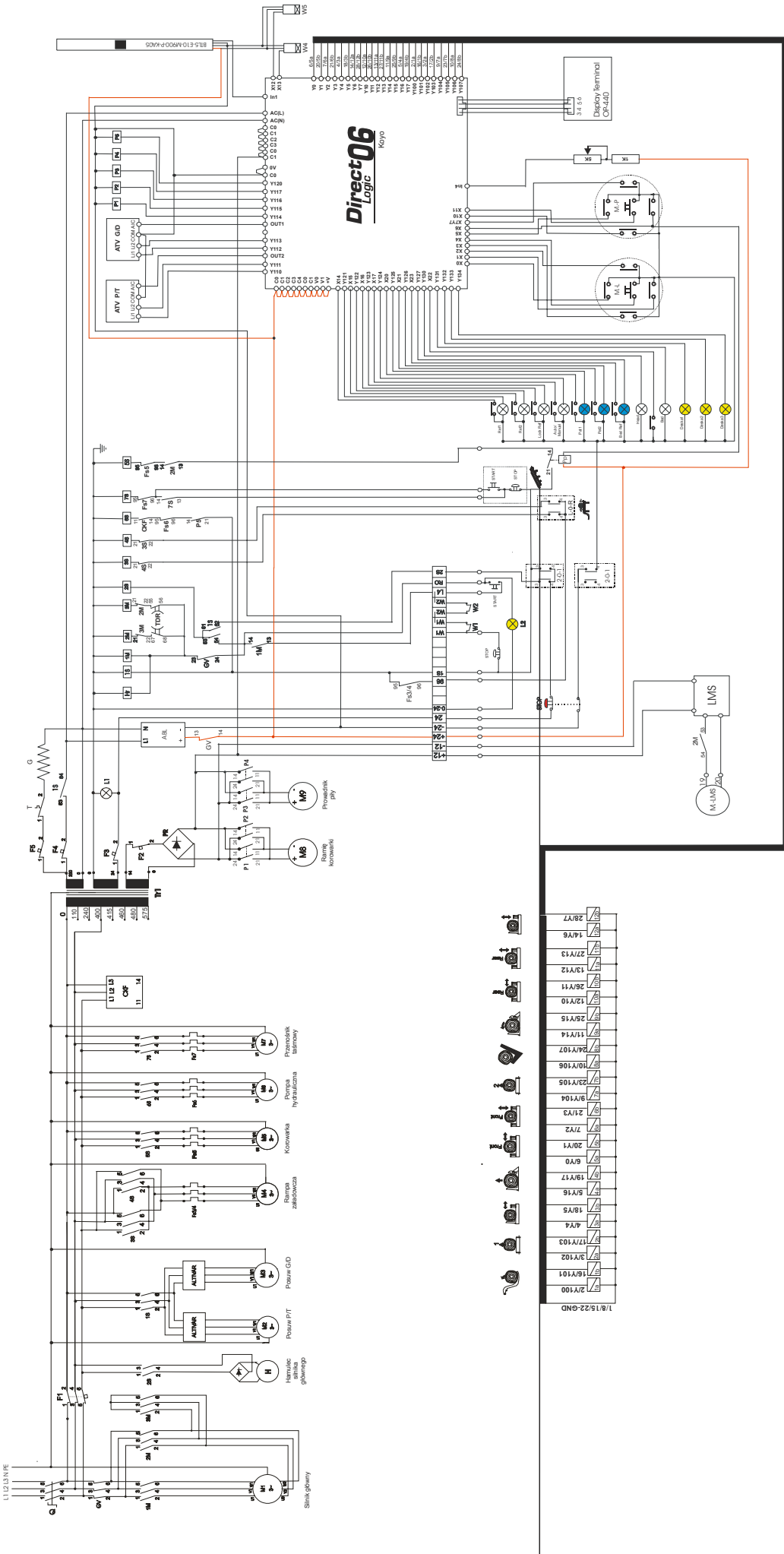

Direct06
Logix
Koyo

- 28/17
- 14/8
- 27/13
- 13/12
- 28/14
- 12/10
- 28/15
- 11/14
- 24/107
- 10/106
- 23/105
- 9/104
- 2/13
- 7/2
- 20/1
- 8/0
- 19/17
- 5/16
- 18/5
- 4/4
- 17/103
- 3/102
- 18/101
- 2/100
- 1/8/15/22-GND

10.7 Wykaz komponentów elektrycznych

Oznaczenie	Nazwa-typ	numer WM
Q ¹	Wyłącznik ABB OT45E3	
GV	Wyłącznik silnikowy GV3ME40	090436
1M, 2M	Stycznik LC1 D18 B7	084306
3M	Stycznik LC1 D09 B7	084305
2S, 5S, 6S, 7S	Stycznik LC1K0610B7	084308
1S, 3S, 4S	Stycznik LC1K0601B7	084309
F1	Wyłącznik modułowy C60N C16 24350	092483
F2	Wyłącznik modułowy C60N C4 24334	092857
F3	Wyłącznik modułowy C60N C6 24399	
F4, F5	Wyłącznik modułowy C60N C2 24396	088278
F6	Wyłącznik modułowy C60N C1 24395	084454
TR1	Transformator TMM800	
TDR	Przełącznik czasowy LADS2	084037
PR	Mostek prostowniczy KBPC3508	084318
L1, L10, L11	Lampka kontrolna M22 biała	090488
M1	Silnik napędu piły Sg160L2 HL	087397
M2	Silnik posuwu P/T STKg80X 4C2	086530
M3	Silnik posuwu G/D STKg80X6/4L2	086770
M4	Silnik rampy załadowniczej	
M5	Silnik korowarki STKg71X 2C	086389
M6	Silnik zasilacza hydraulicznego SLg100L-4PC	
M7	Silnik przenośnika taśmowego	
M8	Silnik ramienia korowarki	P09698-1
M9	Silnik osłony piły	P09698-1
M-LMS	Pompa układu smarowania piły	033492
LMS	Układ smarowania piły	087346
P1	Potencjometr 357-5K	091818
ATV	Regulator prędkości silnika posuwu P/T i G/D ATV31HU11N4	093488
W1, W2	Wyłącznik krańcowy GKMC03W2	087650
W3	Czujnik analogowy BTL5-E10-M0900-P-KA05	088297
W4, W5	Wyłącznik indukcyjny BES-516-347-M0-C-03	090261
W6	Wyłącznik awaryjny ciągnowy XY2CH13250	090994
Ps2	Wyłącznik awaryjny XB4 BS542	086556
Ps1/L1, Ps11	Przycisk START-STOP M22	090452
Hr	Licznik XB5 DSB	091356
Sw1	Wyłącznik kluczykowy M22	091361
Sw2	Wyłącznik korowarki	091467
Sw3	Przełącznik przenośnika roleczkowego	091359
Sw4	Przełącznik rampy załadowniczej	091360
P1, P2, P3, P4, P5, Pp	Przełącznik Finder 40.52.24V DC	090515
Direct 06	Sterownik PLC D0-06DR	051680
OP440	Panel operatorski OP440	088142
M-L, M-P	Manipulator HLU110-IT	090123
L12, L13, L14	Lampka kontrolna M22 żółta 24V	090450
ABL	Zasilacz ABL7RE2405	089814

CKF	Przełącznik kontroli faz RM4TG20	084452
T	Wyłącznik termiczny SAREL S17561	087389
G	Element grzejny SAREL S17502	087388
Fs3/4, Fs6	Przełącznik termiczny LR2 K0316	084456
Fs5	Przełącznik termiczny LR2 K0310	
Fs7	Przełącznik termiczny LRD08	092856
Ps3/L3, Ps4/L4, Ps5/L5, Ps6/L6	Przycisk monostabilny M22 płaski biały, podświetlany	093192
Ps7/L7,Ps8/L8, Ps9/L9	Przycisk monostabilny M22 płaski niebieski, podświetlany	093118

¹ Komponenty zaznaczone kolorem pomarańczowym, znajdują się wewnątrz głównej skrzynki elektrycznej.