

INDUSTRIAL PRODUCTS

Parts Manual

LT300

rev. B1.02



Safety is our #1 concern! Read and understand all safety information and instructions before operating, setting up or maintaining this machine.

January 2001

Form #991

Table of Contents

Section-Page

SECTION 1	GENERAL INFORMATION	1-1
1.1	How To Use The Parts List	1-1
1.2	Sample Assembly	1-1
SECTION 2	BLADE GUIDES & ARM	2-1
2.1	Blade Guide Assembly, Idle Side.....	2-1
2.2	Blade Guide Assembly, Idle Side (Block, Optional)	2-3
2.3	Blade Guide Assembly, Drive Side.....	2-5
2.4	Blade Guide Assembly, Drive Side (Block, Optional).....	2-7
2.5	Blade Guide Arm.....	2-9
SECTION 3	BLADE WHEELS & TENSIONER	3-1
3.1	Drive Shaft Assembly.....	3-1
3.2	Idle Shaft/Brake Drum	3-2
3.3	Blade Wheel Kit, Belted (Standard).....	3-3
3.4	Blade Wheel Kit, Crowned (Optional).....	3-5
3.5	Brake Assembly.....	3-7
3.6	Blade Motor Drive Assembly.....	3-9
SECTION 4	SAW HEAD	4-1
4.1	Board Return	4-1
4.2	Board Return Guide.....	4-2
4.3	Covers & Sawdust Chute.....	4-3
4.4	Blow-Off Assembly.....	4-5
4.5	Laser Assembly	4-6
4.6	Decals, LT300	4-8
4.7	Decals, Operator Station.....	4-10
4.8	Head/Air Box Control Assembly	4-11
SECTION 5	UP/DOWN SYSTEM	5-1
5.1	Mast Pads & Rollers.....	5-1
5.2	Bearing Rails	5-3
5.3	Up/Down Ballscrew Drive	5-4
5.4	Ballscrew Mount (Middle)	5-6
5.5	Ballscrew Mount (Top)	5-8
5.6	Transducer & Head Stop	5-9

Table of Contents

Section-Page

SECTION 6	POWER FEED	6-1
6.1	Upper Track Rollers	6-1
6.2	Lower Track Rollers.....	6-3
6.3	Power Feed Drive	6-5
6.4	Feed Chain & Stops.....	6-7
6.5	Lower Wireway	6-8
SECTION 7	BED FRAME ASSEMBLY	7-1
7.1	Bed Rails	7-1
7.2	Wireway Assembly	7-2
7.3	Cable Carrier	7-4
7.4	Stationary Legs.....	7-5
7.5	Board Return Roller Assembly	7-7
SECTION 8	HYDRAULIC SYSTEM	8-1
8.1	Hydraulic Hoses, LT300	8-1
8.2	Hydraulic Valve.....	8-3
8.3	Hydraulic Log Turner.....	8-5
8.4	Hydraulic Log Side Supports	8-7
8.5	Hydraulic Log Clamp	8-9
8.6	Hydraulic Log Clamp, Standard.....	8-11
8.7	Hydraulic Log Clamp, Optional.....	8-13
8.8	Hydraulic Toe Board	8-15
8.9	Power Toe Roller.....	8-17
8.10	Hydraulic Pump & Tank	8-19
SECTION 9	MISCELLENEOUS	9-1
9.1	Lube System	9-1
9.2	Pressure Lube System (Optional).....	9-3
9.3	Tools	9-5
9.4	Manuals	9-6
SECTION 10	OPERATOR STATION	10-1
10.1	Frame, Rails & Ladder	10-1
10.2	Seat & Joystick Controls	10-3
10.3	Air Supply	10-5
SECTION 11	CAB OPTION	11-1
11.1	Cab.....	11-1
11.2	Rear Panel.....	11-3
11.3	Right Panel	11-5

Table of Contents

Section-Page

11.4	Front Panel.....	11-7
11.5	Left Panel.....	11-8
11.6	Roof.....	11-9

INDEX

I

SECTION 1 GENERAL INFORMATION

1.1 How To Use The Parts List

- Use the table of contents or index to locate the assembly that contains the part you need.
- Go to the appropriate section and locate the part in the illustration.
- Use the number pointing to the part to locate the correct part number and description in the table.
- Parts shown indented under another part are included with that part.
- Parts marked with a diamond (◆) are only available in the assembly listed above the part.

See the sample table below. Sample Part #A01111 includes part F02222-2 and subassembly A03333. Subassembly A03333 includes part S04444-4 and subassembly K05555. The diamond (◆) indicates that S04444-4 is not available except in subassembly A03333. Subassembly K05555 includes parts M06666 and F07777-77. The diamond (◆) indicates M06666 is not available except in subassembly K05555.

1.2 Sample Assembly				
REF	DESCRIPTION (◆ Indicates Parts Available In Assemblies Only)	PART #	QTY.	
	SAMPLE ASSEMBLY, COMPLETE (INCLUDES ALL INDENTED PARTS BELOW)	A01111	1	
1	Sample Part	F02222-22	1	
	Sample Subassembly (Includes All Indented Parts Below)	A03333	1	
2	Sample Part (◆ Indicates Part Is Only Available With A03333)	S04444-4	1	◆
	Sample Subassembly (Includes All Indented Parts Below)	K05555	1	
3	Sample Part (◆ Indicates Part Is Only Available With K05555)	M06666	2	◆
4	Sample Part	F07777-77	1	

To Order Parts:

- From the continental U.S., call **1-800-448-7881** to order parts. Have your customer number, vehicle identification number, and part numbers ready when you call.
- From other international locations, contact the Wood-Mizer distributor in your area for parts.

SECTION 2 BLADE GUIDES & ARM

2.1 Blade Guide Assembly, Idle Side

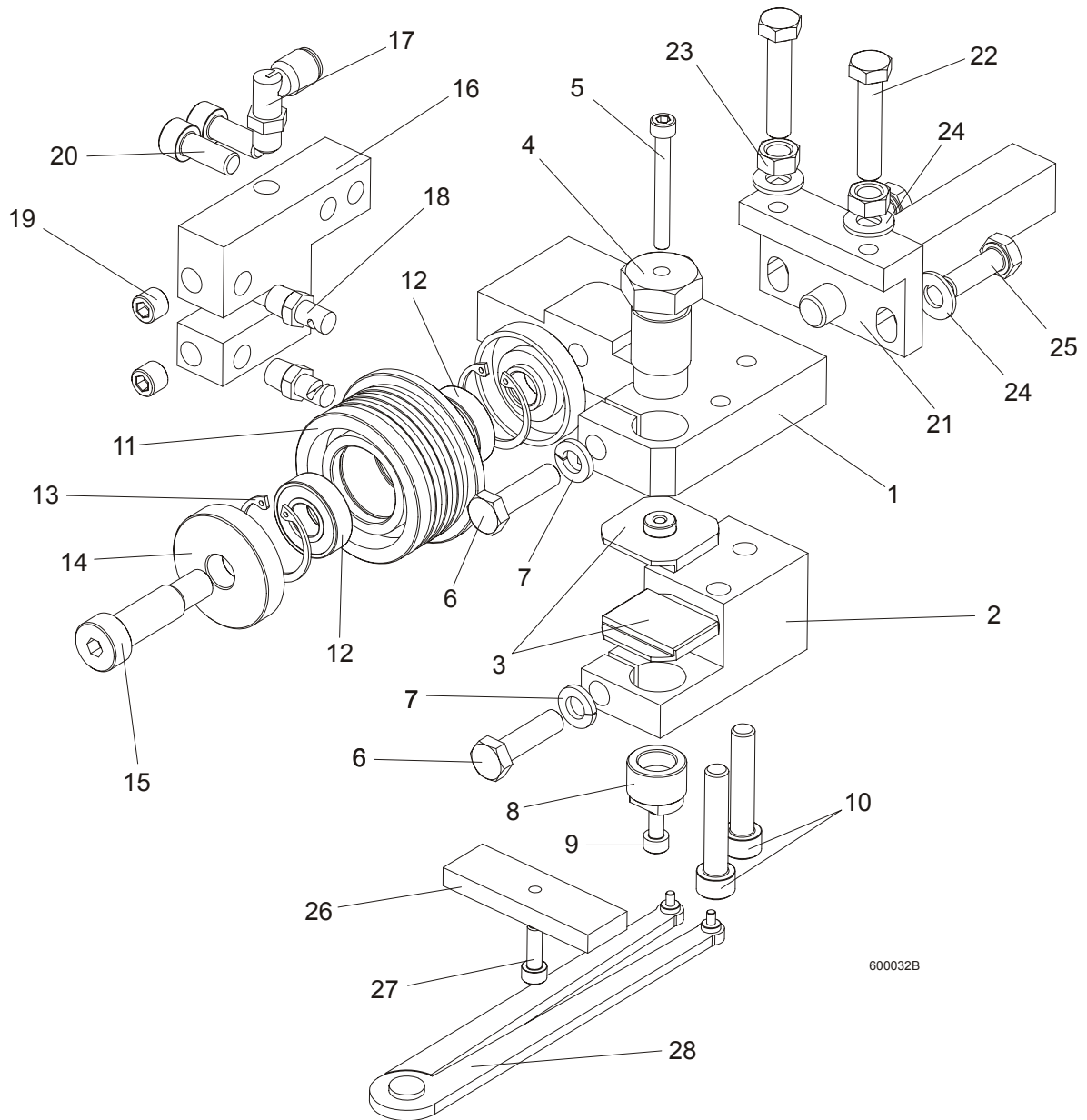

600032B

REF	DESCRIPTION (◆ Indicates Parts Available In Assemblies Only)	PART #	QTY.	
	BLADE GUIDE ASSEMBLY, IDLE SIDE	090943	1	
	BLADE GUIDE ASSEMBLY, IDLE SIDE, EXTENDED (for optional use with 1 1/2" blades)	092997	1	
1	Block, Blade Guide Mount Zinc-plated	090947-1	1	
2	Block, Lower Ceramic Pad Mount Zinc-plated	090948-1	1	
3	Block, Blade Guide Zinc	093430-1	2	
4	Bolt, Upper Pad Adjustment Zinc-plated	089515-1	1	
5	Screw, M5x45 DIN912 A2-70 Hex Socket Head Cap Stainless Steel	F81000-24	1	
6	Bolt, M8x30 DIN933 A2-70 Stainless Steel	F81002-27	2	
7	Washer, 8.2 Split Lock Zinc	F81054-4	2	
8	Screw, Lower Pad Adjuster Zinc-plated	090945-1	1	
9	Screw, M5x10 DIN912 A2-70 Hex Socket Head Cap Stainless Steel	F81000-23	1	
10	Screw, M8x40-8.8 Hex Socket Head Cap Zinc	F81002-29	2	
	Roller, Blade Guide Narrow W/Bearing	088261	1	
	Roller, Blade Guide W/Bearing, Extended	092939	1	
11	Roller, Blade Guide Narrow	087889	1	
12	Bearing, 6001 2RSR NACHI	087893	2	
13	Ring, W28 Inside Retaining	F81090-9	2	
14	Washer, Blade Guide Roller Spacer Zinc-plated	087891-1	2	
15	Screw, 12/M10x30 12.9 ISO 7379 Socket Head Shoulder	F81003-70	1	
	Screw, 12/M10x35 12.9 ISO 7379 Socket Head Shoulder, (used with the Extended Roller only)	F81003-48	1	
16	Block, Nozzle Mounting Zinc-plated	090487-1	1	
17	Fitting, 90° Elbow 1/8NPT-1/4 Tube Swivel	P09736	1	
18	Nozzle, Blade Lube Spray	033479	2	
19	Plug, M10x1 DIN 906 BN40 "BOSSARD"	F81015-3	2	
20	Screw, M8x20-8.8 Hex Socket Head Cap Zinc	F81002-30	2	
21	Pivot Weldment, Blade Guide Zinc-plated	089509-1	1	
22	Bolt, M8x40 DIN933 A2-70 Stainless Steel	F81002-28	2	
23	Nut, M8 DIN934 A2-70 Stainless Steel	F81032-7	2	
24	Washer, 8.4 Zinc Flat	F81054-1	4	
25	Bolt, M8x25 DIN933 A2-70 Stainless Steel	F81002-26	2	
	Block, Blade Guide Alignment	090951	1	
26	Block, Blade Guide Alignment Zinc-plated	090805-1	1	
27	Screw, M5x16-8.8 Hex Socket Head Cap Zinc	F81000-25	1	
28	Tool, 62860-3 (PERSCHMAN) Lower Pad Adjustment	090949	1	

2.2 Blade Guide Assembly, Idle Side (Block, Optional)

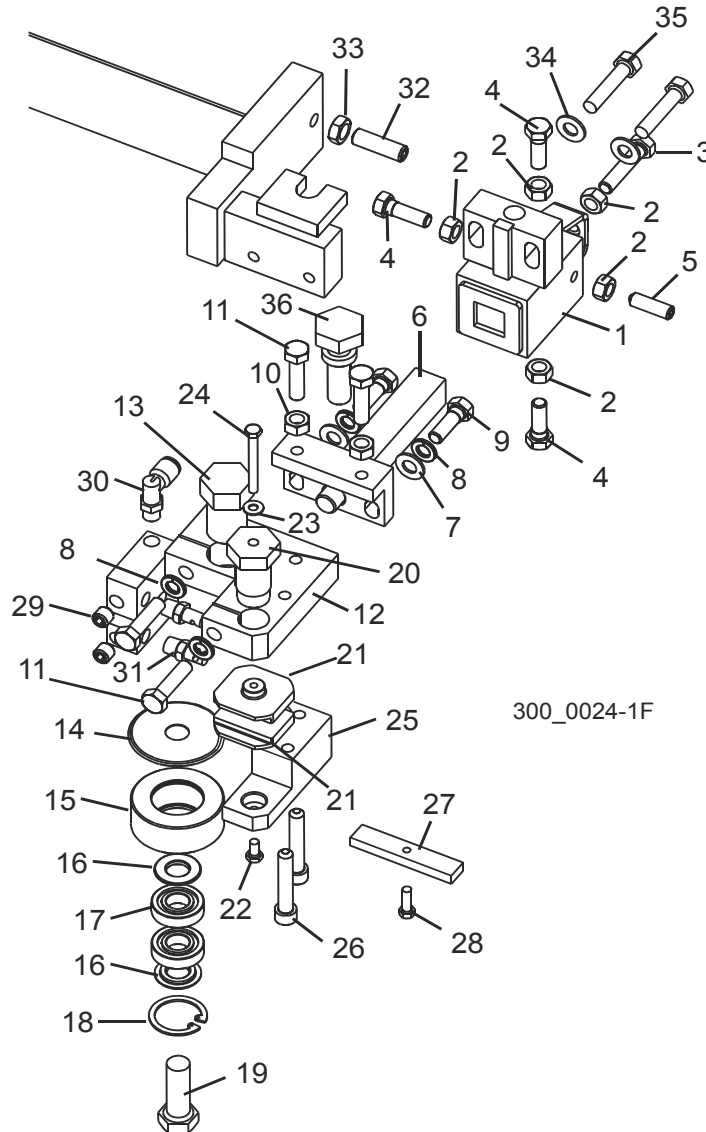

REF	DESCRIPTION (◆ Indicates Parts Available In Assemblies Only)	PART #	QTY.	
	GUIDE ASSEMBLY, IDLE SIDE BLOCK/ROLLER	035200	1	
	Block Assembly, Idle Side Blade Guide	036099	1	
1	Block Weldment, Blade Guide Mount	035219	1	◆
2	Nut, 5/16-18 Hex	F05010-17	5	
3	Bolt, 5/16-18 x 1 1/2" Hex Head Full Thread Stainless Steel	F05006-119	1	
4	Bolt, 5/16-18 x 1" Hex Head Stainless Steel	F05006-88	3	
5	Screw, 5/16-18 x 1" Socket Head Flat Point Stainless Steel	F05006-122	1	
6	Shaft Weldment, Block Guide Pivot	035209	1	
7	Washer, 5/16" SAE Flat	F05011-17	2	

2

Blade Guide Assembly, Idle Side (Block, Optional)

8	Washer, 5/16" Split Lock	F05011-13	4	
9	Bolt, 5/16-18 x 1" Hex Head Stainless Steel	F05006-88	2	
10	Nut, 5/16-18 Hex	F05010-17	2	
11	Bolt, 5/16-18 x 1 1/4" Hex Head Stainless Steel	F05006-118	4	
12	Block Weldment, Upper Blade Guide	035206	1	
13	Bolt, Blade Guide Roller Mount	035215	1	
14	Hood, Blade Guide Back Roller	042848	1	
	Roller Assembly, Blade Guide	023977	1	
15	Housing, Blade Guide Roller	017223	1	◆
16	Spacer, Blade Guide Roller	018948	2	
17	Bearing, R8-2RS Blade Guide	015975	2	
18	Ring, 1 1/8" IR 3000x112 Retaining	F04254-1	1	
19	Bolt, 1/2-13 x 1 1/2" Hex Head	F05008-4	1	
20	Bolt, Blade Guide Block Mount	035216	1	
21	Block, Blade Guide Wear (Standard for 1 1/2" Blades)	052309 ¹	2	
	Block, Blade Guide Wear (Optional for 1 1/4" Blades)	052355 ¹	2	
	Block, Blade Guide Zinc	093430-1	2	
22	Screw, #10-32 x 3/8" Hex Head Stainless Steel	F05004-171	1	
23	Washer, #10 Brass	042867	1	
24	Bolt, #10-32 x 1 3/4" Hex Head Stainless Steel	F05004-178	1	
25	Block, Lower Blade Guide	035213	1	
26	Screw, 5/16-18 x 1 3/4" Socket Head	F05006-65	2	
27	Block, Blade Guide Alignment	035799	1	
28	Screw, #10-32 x 5/8" Hex Head	F05004-152	1	
29	Fitting, 1/8" NPT Socket Pipe Plug	P30127	2	
30	Fitting, 1/8" MPT x 1/4" Tube Swivel Elbow	P09736	1	
31	Fitting, Blade Lube Spray Nozzle	033479	2	
32	BOLT, 3/8-16 X 1 1/2" HEX HEAD FULL THREAD	F05007-17	1	
33	NUT, 3/8-16 HEX JAM	F05010-29	1	
34	WASHER, 5/16" SAE FLAT	F05011-17	2	
35	BOLT, 5/16-18 X 1 1/2" HEX HEAD	F05008-96	2	
36	BOLT, BLADE GUIDE VERTICAL ADJUSTMENT	035656	1	

¹ 052309 blocks for use with 1 1/2" blades provided as standard equipment. 052355 blocks available for optional use with 1 1/4" blades.

2.3 Blade Guide Assembly, Drive Side

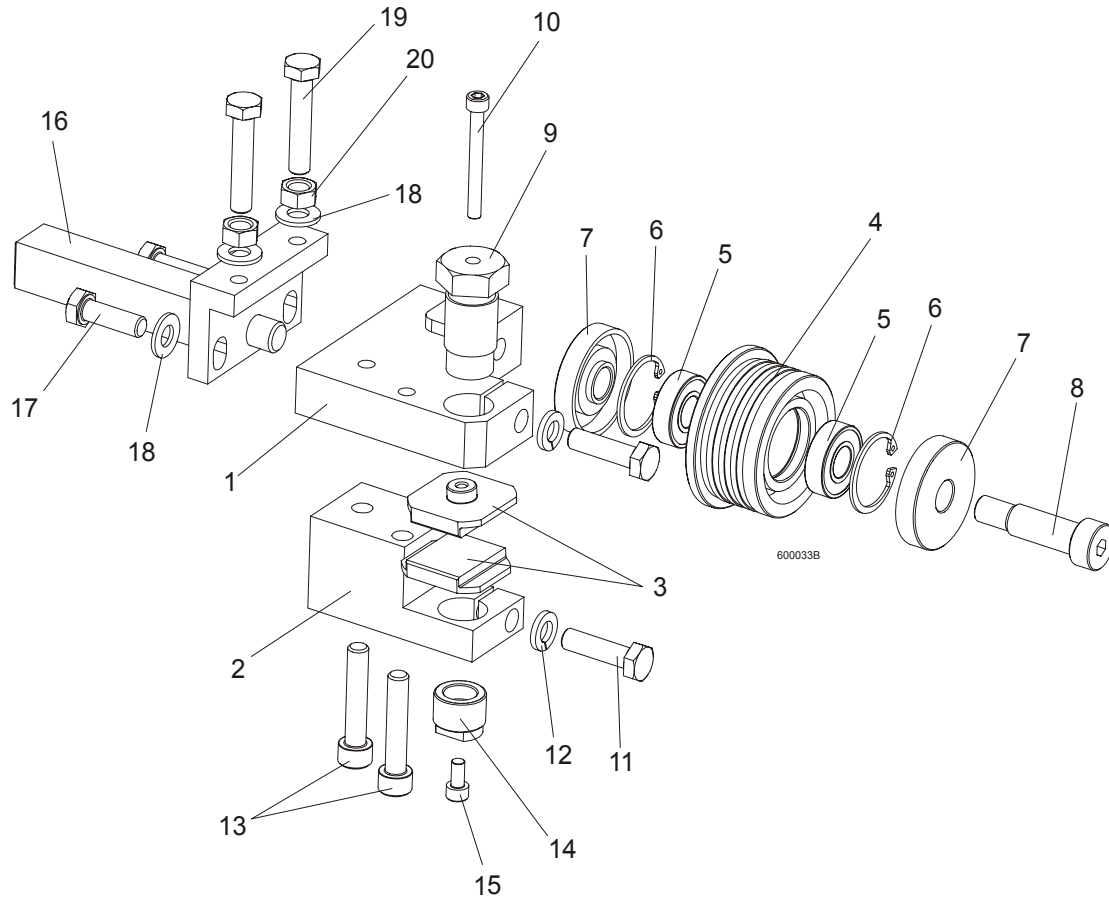

REF	DESCRIPTION (◆ Indicates Parts Available In Assemblies Only)	PART #	QTY.	
	BLADE GUIDE ASSEMBLY, DRIVE SIDE	090942	1	
	BLADE GUIDE ASSEMBLY, DRIVE SIDE, EXTENDED (for optional use with 1 1/2" blades)	092998	1	
1	Block, Blade Guide Mount Zinc-plated	090944-1	1	
2	Block, Lower Ceramic Pad Mount Zinc-plated	090946-1	1	
3	Block, Blade Guide Zinc	093430-1	2	
	Roller, Blade Guide Narrow W/Bearing	088261	1	
	Roller, Blade Guide W/Bearing, Extended	092939	1	
4	Roller, Blade Guide Narrow	087889	1	
5	Bearing, 6001 2RSR NACHI	087893	2	◆
6	Ring, W28 Inside Retaining	F81090-9	2	
7	Washer, Blade Guide Roller Spacer Zinc-plated	087891	2	
8	Screw, 12/M10x30 12.9 ISO 7379 Socket Head Shoulder	F81003-70	1	
	Screw, 12/M10x35 12.9 ISO 7379 Socket Head Shoulder (used with the Extended Roller only)	F81003-48	1	

2*Blade Guide Assembly, Drive Side*

9	Bolt, Upper Pad Adjustment	089515	1	
10	Screw, M5x45 DIN912 A2-70 Hex Socket Head Cap Stainless Steel	F81000-24	1	
11	Bolt, M8x30 DIN933 A2-70 Stainless Steel	F81002-27	2	
12	Washer, 8.2 Split Lock Zinc	F81054-4	2	
13	Screw, M8x40-8.8 Hex Socket Head Cap Zinc	F81002-29	2	
14	Screw, Lower Pad Adjustment Zinc-plated	090945-1	1	
15	Screw, M5x10 DIN912 A2-70 Hex Socket Head Cap Stainless Steel	F81000-23	1	
16	Pivot Weldment, Blade Guide Zinc-plated	089509-1	1	
17	Bolt, M8x25 DIN933 A2-70 Stainless Steel	F81002-26	2	
18	Washer, 8.4 Zinc Flat	F81054-1	4	
19	Bolt, M8x40 DIN933 A2-70 Stainless Steel	F81002-28	2	
20	Nut, M8 DIN934 A2-70 Stainless Steel	F81032-7	2	

2.4 Blade Guide Assembly, Drive Side (Block, Optional)

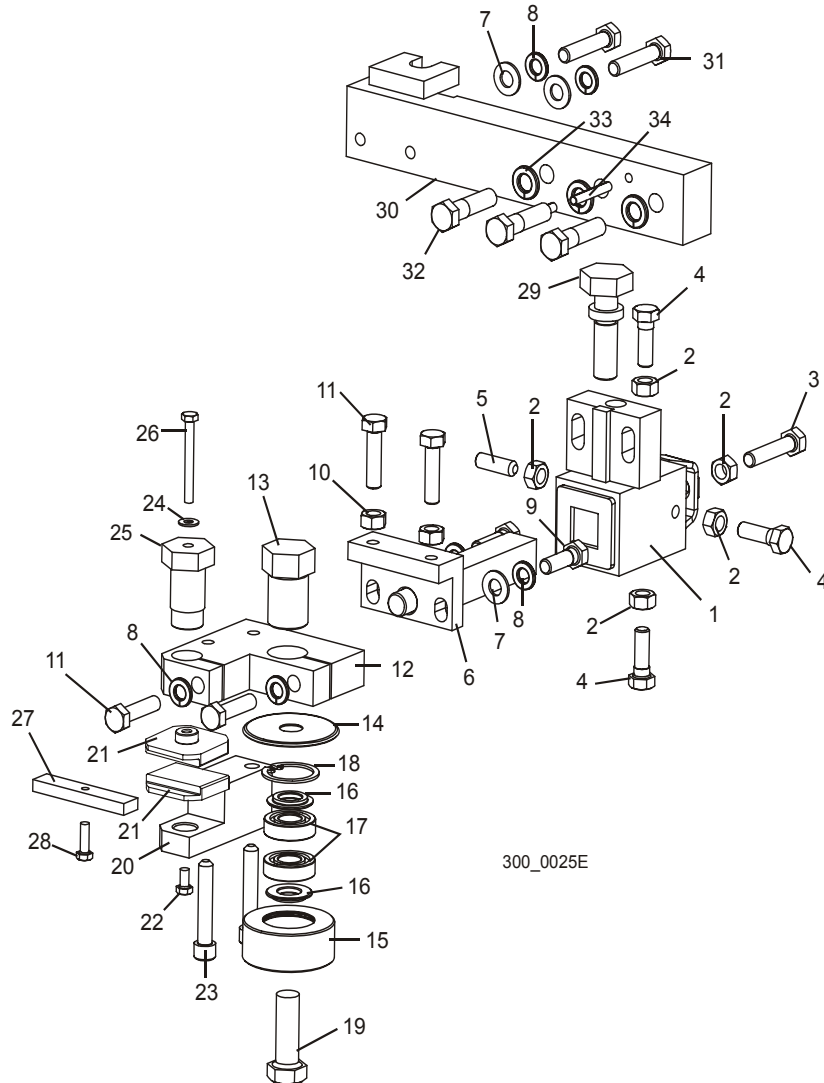

REF	DESCRIPTION (◆ Indicates Parts Available In Assemblies Only)	PART #	QTY.
	GUIDE ASSEMBLY, DRIVE SIDE BLOCK/ROLLER	035201	1
	Block Assembly, Blade Guide Mount	036100	1
1	Block Weldment, Blade Guide Mount	035219	1 ◆
2	Nut, 5/16-18 Hex	F05010-17	5
3	Bolt, 5/16-18 x 1 1/2" Hex Head Full Thread Stainless Steel	F05006-119	1
4	Bolt, 5/16-18 x 1" Hex Head Stainless Steel	F05006-88	3
5	Screw, 5/16-18 x 1" Socket Head Flat Point Stainless Steel Set	F05006-122	1
6	Shaft Weldment, Block Guide Pivot	035209	1
7	Washer, 5/16" SAE Flat	F05011-17	2
8	Washer, 5/16" Split Lock	F05011-13	4

2

Blade Guide Assembly, Drive Side (Block, Optional)

9	Bolt, 5/16-18 x 1" Hex Head Stainless Steel	F05006-88	2	
10	Nut, 5/16-18 Hex	F05010-17	2	
11	Bolt, 5/16-18 x 1 1/4" Hex Head Stainless Steel	F05006-118	4	
12	Block Weldment, Upper Blade Guide	035207	1	
13	Bolt, Blade Guide Roller Mount	035215	1	
14	Hood, Blade Guide Back Roller	042848	1	
	Roller Assembly, Blade Guide	023977	1	
15	Housing, Blade Guide Roller	017223	1	◆
16	Spacer, Blade Guide Roller	018948	2	
17	Bearing, R8-2RS Blade Guide	015975	2	
18	Ring, 1 1/8" IR 3000x112 Retaining	F04254-1	1	
19	Bolt, 1/2-13 x 1 1/2" Hex Head	F05008-4	1	
20	Block, Lower Blade Guide	035214	1	
21	Block, Blade Guide Wear (Standard for 1 1/2" Blades)	052309 ¹	2	
	Block, Blade Guide Wear (Optional for 1 1/4" Blades)	052355 ¹	2	
	Block, Blade Guide Zinc	093430-1	2	
22	Screw, #10-32 x 3/8" Hex Head Stainless Steel	F05004-171	1	
23	Screw, 5/16-18 x 1 3/4" Socket Head	F05006-65	2	
24	Washer, #10 Brass	042867	1	
25	Bolt, Blade Guide Block Mount	035216	1	
26	Bolt, #10-32 x 1 3/4" Hex Head Stainless Steel	F05004-178	1	
27	Block, Blade Guide Alignment	035799	1	
28	Screw, #10-32 x 5/8" Hex Head	F05004-152	1	
29	BOLT, BLADE GUIDE VERTICAL ADJUSTMENT	035656	1	
30	ARM WELDMENT, DRIVE SIDE BLADE GUIDE MOUNT	035658	1	
31	WASHER, 5/16" SAE FLAT	F05011-17	2	
32	WASHER, 5/16" SPLIT LOCK	F05011-13	2	
33	BOLT, 5/16-18 X 1 1/2" HEX HEAD FULL THREAD STAINLESS STEEL	F05006-119	2	
34	BOLT, 3/8-16 X 1 1/2" HEX HEAD GRADE 5	F05007-78	3	
35	WASHER, 3/8" SPLIT LOCK	F05011-4	3	
36	PIN, 3/16" X 1 1/4" ROLL	F05012-16	2	

¹ 052309 blocks for use with 1 1/2" blades provided as standard equipment. 052355 blocks available for optional use with 1 1/4" blades.

2.5 Blade Guide Arm

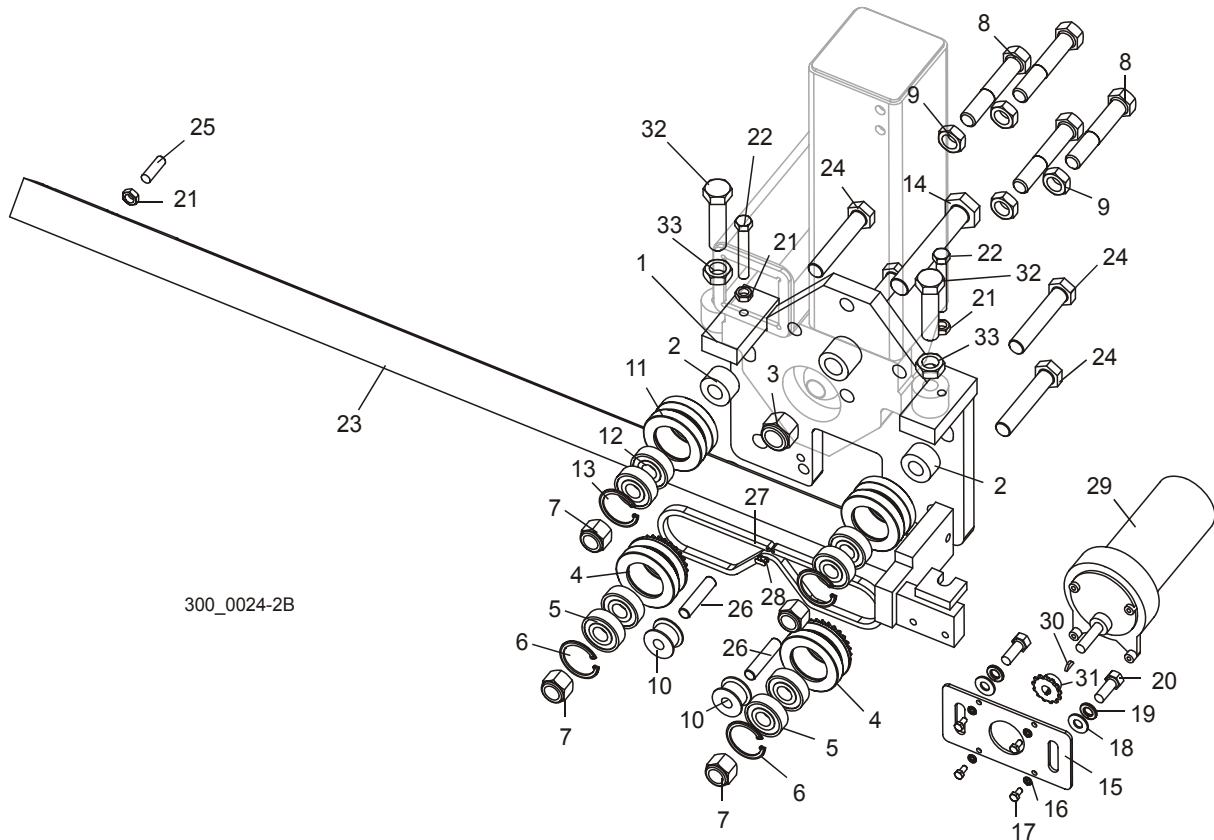

300_0024-2B

REF	DESCRIPTION (◆ Indicates Parts Available In Assemblies Only)	PART #	QTY.	
	PLATE ASSEMBLY, BLADE GUIDE ARM	042540	1	
	Blade Guide Parts (See Section 2.2)			
1	Plate Weldment, Blade Guide Arm	042539	1	
2	Spacer, .625" x .717" x 1 1/4"	042531	4	
3	Nut, 3/4-16 Hex Nylon Lock	F05010-157	1	
	Roller Assembly, Blade Guide Arm Drive	042542	2	
4	Roller, Blade Guide Arm W/Sprocket	042541	1	◆
5	Bearing, 5/8" x 1.5748" x .4724"	P06030-1	2	
6	Ring, 1.575" ID Beveled 5002-156 Retaining	F04254-8	1	
7	Nut, 5/8-18 Hex Nylon Lock	F05010-71	4	
8	Bolt, 5/8-16 x 3 1/2" Hex Head Full Thread	F05009-16	4	
9	Nut, 5/8-18 Hex Jam	F05010-11	4	
10	Roller, Chain Idler	S09999	2	
	Roller Assembly, Blade Guide Arm Idle	042543	2	
11	Roller, 2 1/2" V-Groove	042536	1	◆
12	Bearing, 5/8" x 1.5748" x .4724"	P06030-1	2	

2 Blade Guide Rollers & Arm

Blade Guide Arm

13	Ring, 1.575" ID Beveled 5002-156 Retaining	F04254-8	1	
14	Bolt, 3/4-16 x 4 1/2" Hex Head Grade 8	F05009-97	1	
15	Plate, Blade Guide Arm Motor Mount	042519	1	
16	Washer, #10 Split Lock	F05011-20	4	
17	Screw, #10-32 x 1/2" Hex Head Machine	F05004-60	4	
18	Washer, 3/8" SAE Flat	F05011-3	2	
19	Washer, 3/8" Split Lock	F05011-4	2	
20	Bolt, 3/8-16 x 1" Hex Head	F05007-7	2	
21	Nut, 3/8-16 Hex Jam	F05010-29	3	
22	Bolt, 3/8-16 x 2 1/2" Hex Head Full Thread Grade 2	F05007-157	2	
23	Arm Weldment, Blade Guide	023962	1	
24	Bolt, 5/8-18 x 3 1/4" Hex Head Grade 5	F05009-98	4	
25	Screw, 3/8-16 x 1 1/4" Socket Head Oval Point Set	F05007-18	1	
26	Pin, 7/16" x 2" Dowel	F05012-110	2	
27	Chain, #25 x 92 Pitch	042443	1	
28	Link, #25 Master	P09983	1	
29	Motor Assembly, 24V 60RPM Gear	035659	1	
	Motor, 24V 1/15HP Gear	033119	1	
	Shaft, Blade Guide Arm Gear Motor	036514	1	
	Gear Kit, Blade Guide Arm Gear Motor	036515	1	
30	Key, #304 Woodruff	036203	1	
31	Sprocket, 25B13x 3/8" w/Set Screw	033120	1	
32	Bolt, 5/8-18 x 2 1/2" Hex Head Full Thread Grade 5	F05009-99	2	
33	Nut, 5/8-18 Hex Jam	F05010-11	2	

SECTION 3 BLADE WHEELS & TENSIONER

3.1 Drive Shaft Assembly

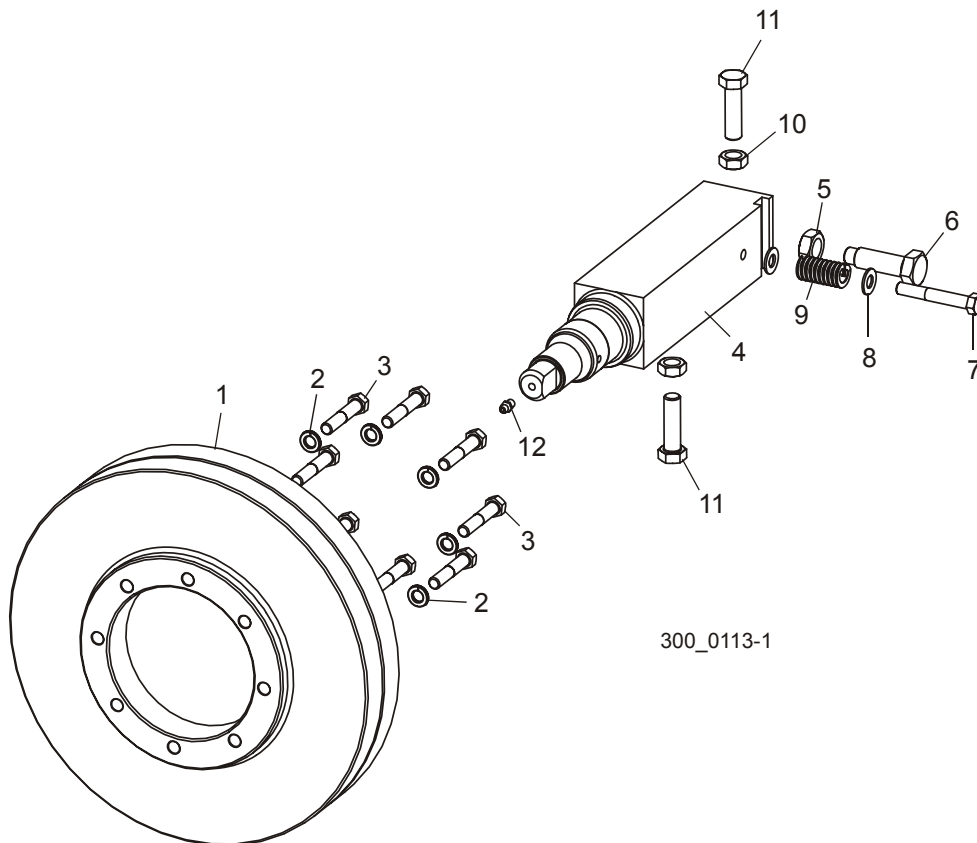

REF	DESCRIPTION (◆ Indicates Parts Available In Assemblies Only)	PART #	QTY.
1	SHEAVE, EAGLE PD DRIVE	046897	1
2	WASHER, 3/8" SPLIT LOCK	F05011-4	8
3	BOLT, 3/8-16 X 2" HEX HEAD GRADE 5	F05007-124	8
4	SHAFT, BLADE WHEEL	017824	1
5	BOLT, DRIVE WHEEL SHAFT RETAINING	034360	1
6	NUT, 5/8-18 HEX JAM	F05010-11	1
7	BOLT, 3/8-16 X 2 1/2" HEX HEAD	F05007-47	1
8	WASHER, 3/8" SAE FLAT	F05011-3	2
9	SPRING, 3/4" OD X 1 1/2" DIE	034430	1
10	BOLT, 1/2-20 X 1 3/4" HEX HEAD FULL THREAD	F05008-127	2
11	NUT, 1/2-20 HEX JAM	F05010-16	2
12	FITTING, 1/4-28 GREASE	P05060	1

3 Blade Wheels & Tensioner

Idle Shaft/Brake Drum

3.2 Idle Shaft/Brake Drum

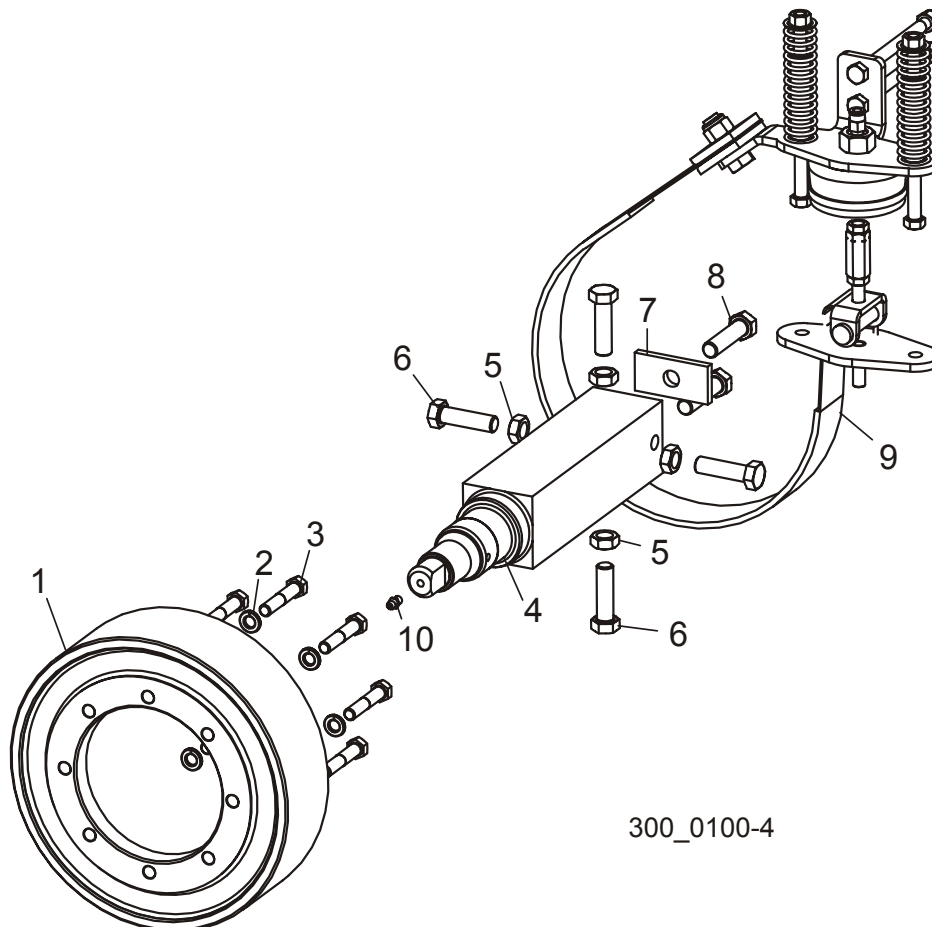

REF	DESCRIPTION (◆ Indicates Parts Available In Assemblies Only)	PART #	QTY.
1	DRUM, BRAKE	045004	1
2	WASHER, 3/8" SPLIT LOCK	F05011-4	8
3	BOLT, 3/8-16 X 2" HEX HEAD GRADE 5	F05007-124	8
4	SHAFT, BLADE WHEEL	033244	1
5	NUT, 1/2-20 HEX JAM	F05010-16	4
6	BOLT, 1/2-20 X 1 3/4" HEX HEAD FULL THREAD	F05008-127	4
7	PLATE, WASHER	042548	1
8	BOLT, 1/2-20 X 2" HEX HEAD FULL THREAD	F05008-126	2
9	BRAKE ACTUATOR & STRAP PARTS (See Section 3.5)		
10	FITTING, 1/4-28 GREASE	P05060	1

3.3 Blade Wheel Kit, Belted (Standard)

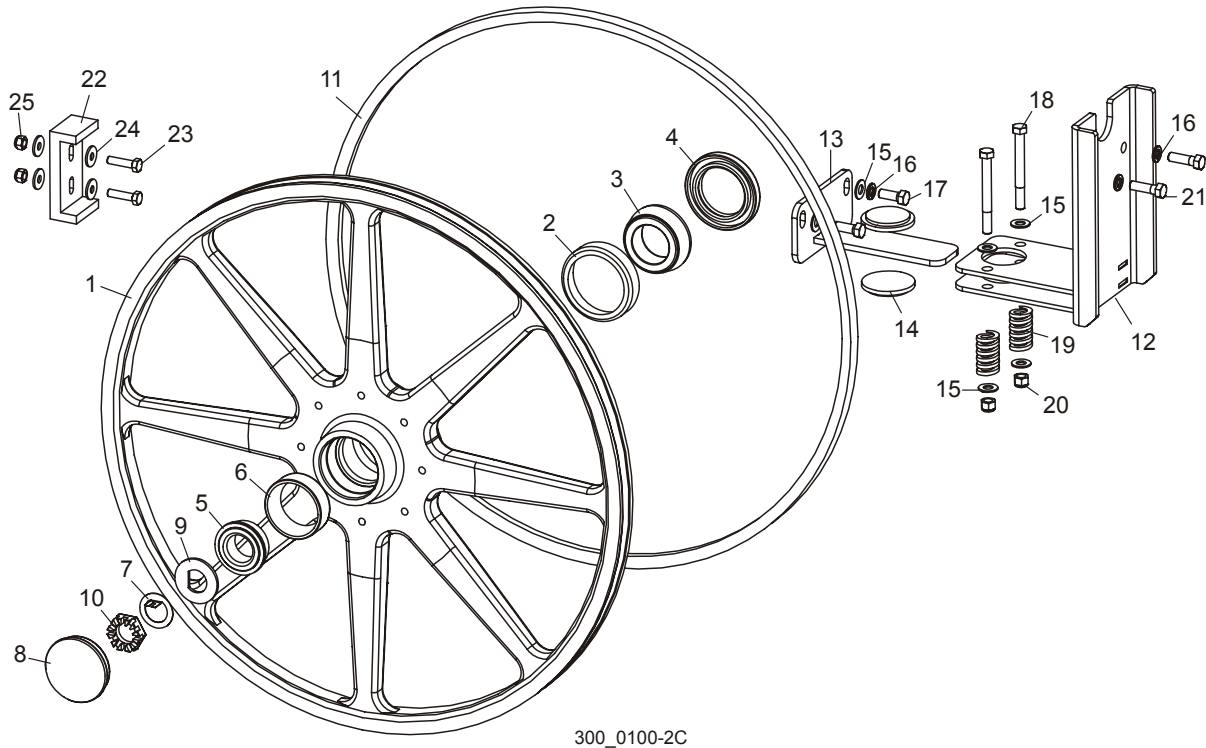

300_0100-2C

REF	DESCRIPTION (◆ Indicates Parts Available In Assemblies Only)	PART #	QTY.	
	WHEEL KIT, BELTED BLADE	036704 ¹	1	◆
	Wheel Assembly, Belted Blade w/Bearings	036632	2	
1	Wheel, 25" Belted Blade	036619	1	◆
2	Race, Inner Bearing	045209	1	
3	Bearing, Inner	045208	1	
4	Seal, Blade Wheel Bearing	045212	1	
5	Bearing, Outer	045210	1	
6	Race, Outer Bearing	045211	1	
7	Washer, Dexter #5-101 Tang	P22686	1	
8	Cap, Hub Dust	033238	1	
9	Washer, Blade Wheel Shaft D	045214	1	
10	Nut, Blade Wheel Shaft	P22776	1	
11	Belt, B75.5	035953	1	
	Dampener Kit, Anti-Vibration	036840	1	
12	Mount Weldment, Dampener Pad	036838	1	
13	Tab Weldment, Dampener	036839	1	
14	Pad, Dampener	036833	2	
15	Washer, 3/8" SAE Flat	F05011-3	6	

3**Blade Wheels & Tensioner**
Blade Wheel Kit, Belted (Standard)

16	Washer, 3/8" Split Lock	F05011-4	4	
17	Bolt, 3/8-16 x 1" Hex Head Grade 5	F05007-87	2	
18	Bolt, 3/8-16 x 3 1/2" Hex Head Grade 5	F05004-123	2	
19	Spring, 1" OD x 1/2" ID x 1 3/4" Heavy Die	036849	2	
20	Nut, 3/8-16 Hex Nylon Lock	F05010-10	2	
21	Bolt, 3/8-16 x 1 1/4" Hex Head Grade 5	F05007-123	2	
	Support Kit, Middle Blade	038493	1	
22	Support Channel, Middle Blade	038491	1	
23	Bolt, 5/16-18 x 1 1/4" Stainless Steel hex Head	F05006-118	2	
24	Washer, 5/16" Flat	F05011-16	4	
25	Nut, 5/16-18 Hex Nylon Lock	F05010-58	2	

¹ Belted blade wheels and block/roller blade guides provided standard on LT300 Rev. A8.00. [See Section 3.4](#) for optional crowned blade wheels used with all-block blade guides. Blade wheels are too heavy to ship together in kit 036704. Order 036632 separately for service. To convert to crowned steel wheels and all-block blade guides, use two 017814 crowned wheel assemblies and one 036706 block blade guide kit.

3.4 Blade Wheel Kit, Crowned (Optional)

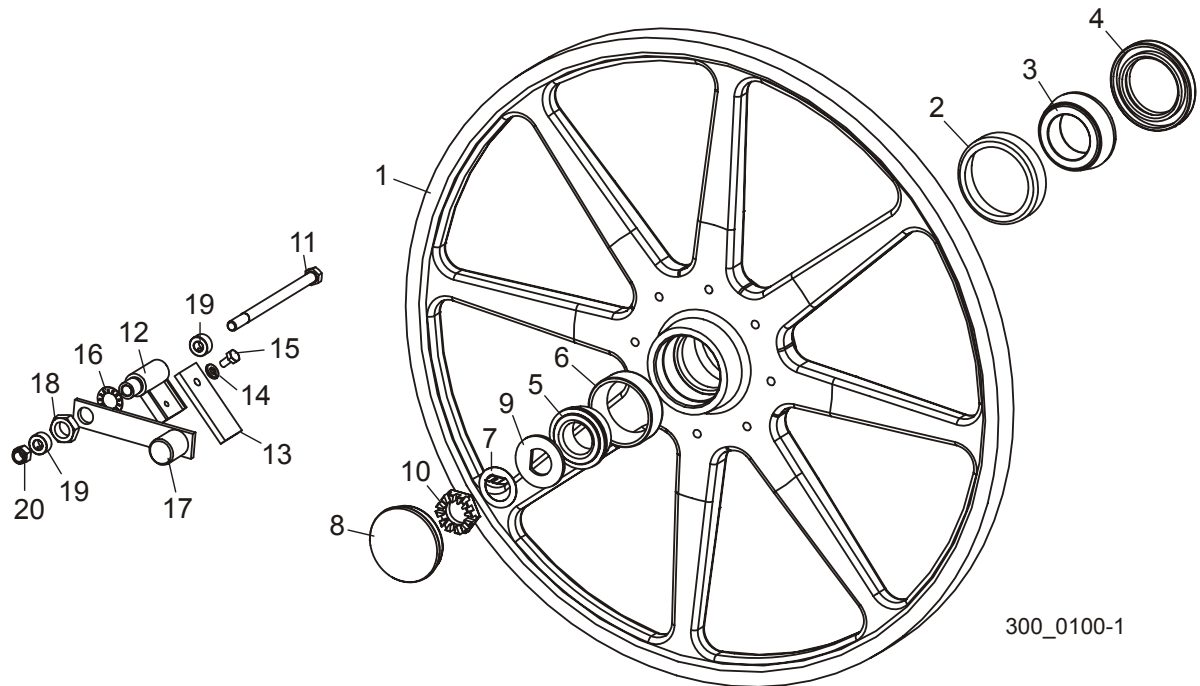

300_0100-1

REF	DESCRIPTION (◆ Indicates Parts Available In Assemblies Only)	PART #	QTY.	
	WHEEL KIT, CROWNED BLADE (TWO COMPLETE BLADE WHEELS)	036703 ¹	1	◆
	Wheel Assembly, Blade w/Bearings	017814 ²	2	
	Wheel Assembly, Blade w/Bearings (Recrowned)	017814-R ³	1	
1	Wheel, 25" Cast Blade	045000	1	◆
	Wheel, 25" Cast Blade (Recrowned)	045000-R ³	1	◆
2	Race, Inner Bearing	045209	1	
3	Bearing, Inner	045208	1	
4	Seal, Blade Wheel Bearing	045212	1	
5	Bearing, Outer	045210	1	
6	Race, Outer Bearing	045211	1	
7	Washer, Dexter #5-101 Tang	P22686	1	
8	Cap, Hub Dust	033238	1	
9	Washer, Blade Wheel Shaft D	045214	1	
10	Nut, Blade Wheel Shaft	P22776	1	
11	Bolt, 3/8-16 x 6" Hex Head	F05007-45	2	
	Scraper Assembly, Drive Side Blade Wheel	042247	2	
12	Pivot Weldment, Wheel Scraper	042240	1	
13	Scraper, Brass Wheel	042245	1	
14	Washer, 1/4" Split Lock	F05011-14	1	
15	Bolt, 1/4-20 x 1/2" Hex Head	F05005-15	1	

3**Blade Wheels & Tensioner***Blade Wheel Kit, Crowned (Optional)*

16	Washer, 5/8" Interior Star Lock	F05011-25	1	
17	Weight Weldment, Wheel Scraper	042248	1	
18	Nut, 5/8-11 Hex Jam	F05010-82	1	
19	Collar, 3/8" ID	042249	4	
20	Nut, 3/8-16 Hex Nylon Lock	F05010-10	2	

¹ Belted blade wheels and block/roller blade guides provided standard on LT300 Rev. A8.00. [See Section 3.3](#) for standard belted blade wheels used with block/roller blade guides. Blade wheels are too heavy to ship together in kit 036703. Order 017814 separately for service. To convert to belted blade wheels and roller/block blade guides, use two 036632 belted wheel assemblies , one 036705 roller/block blade guide kit, one 038493 blade support kit and one 036841 vibration dampening retrofit (rev. A1.00 - A8.00) or one 036840 vibration dampening kit (Rev. A9.00+).

² Dust Cap 033238, D Washer 045214 and Spindle Nut 045216 added to assembly 017814 (11/04).

³ Blade wheels may be recrowned at the factory for extended service life.

3.5 Brake Assembly

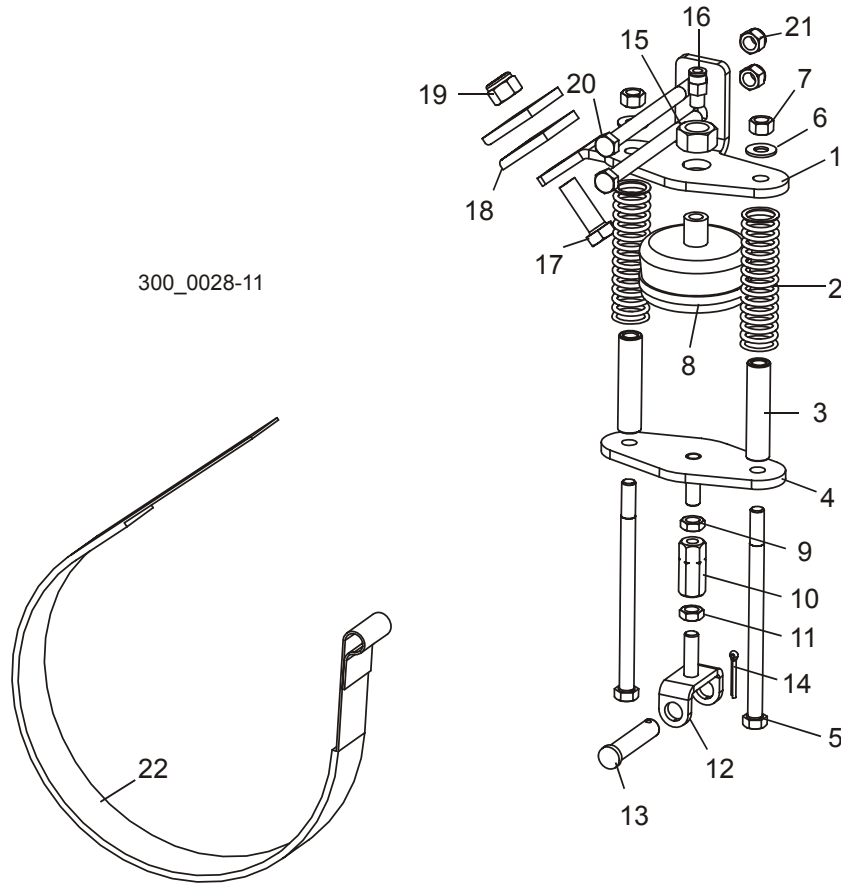

300_0028-11

REF	DESCRIPTION (◆ Indicates Parts Available In Assemblies Only)	PART #	QTY.
	ACTUATOR ASSEMBLY, LT300 BRAKE	033170	1
1	Bracket, Upper Brake Mount	033166	1
2	Spring, Brake	033171	2
3	Spacer, Brake Spring Travel	033169	2
4	Bracket Weldment, Lower Brake Mount	033172	1
5	Bolt, 3/8-16 x 6" Hex Head	F05007-45	2
6	Washer, 3/8" SAE Flat	F05011-3	2
7	Nut, 3/8-16 Hex Lock	F05010-25	2
8	Bag, Brake Air	033168	1
9	Nut, 3/8-24 Hex Jam (Left-Hand Thread)	F05010-166	1
10	Adjuster, Brake Link	033174	1
11	Nut, 3/8-24 Hex Jam	F05010-22	1
12	Bracket Weldment, Brake Link	033175	1
13	Pin, 1/2" x 2 1/4" Clevis	F05012-81	1
14	Pin, 1/8" x 1" Cotter	F05012-1	1
15	Nut, 5/8-11 Hex	F05010-5	1

3 Blade Wheels & Tensioner

Brake Assembly

16	Fitting, 1/8" NPT x 1/4" Tube	P03078	1	
17	Bolt, 1/2-13 x 1 1/2" Hex Head	F05008-4	1	
18	Plate, Brake Strap Clamp	S04195	2	
19	Nut, 1/2-13 Hex Nylon Lock	F05010-8	1	
20	Bolt, 3/8-16 x 5" Hex Head Grade 2	F05007-5	2	
21	Nut, 3/8-16 Hex Nylon Lock	F05010-10	2	
22	Strap, 9 1/2" Dia. Brake	033178	1	

3.6 Blade Motor Drive Assembly

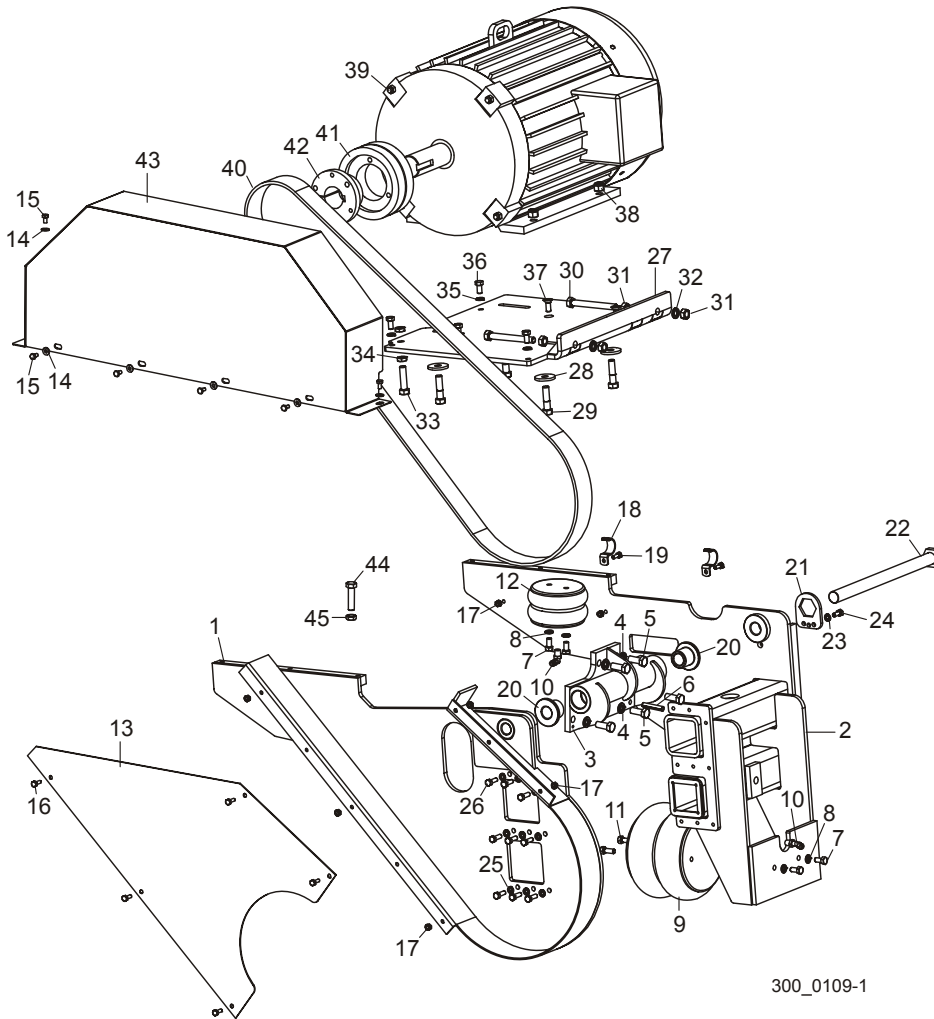

300_0109-1

REF	DESCRIPTION (◆ Indicates Parts Available In Assemblies Only)	PART #	QTY.
1	BRACKET WELDMENT, FRONT MOTOR MOUNT	033211	1
2	BRACKET WELDMENT, REAR MOTOR MOUNT	033216	1
3	PIVOT WELDMENT, MOTOR MOUNT	033206	1
4	WASHER, 1/2" SPLIT LOCK	F05011-9	5
5	BOLT, 1/2-13 X 1 1/4" HEX HEAD GRADE 5	F05008-37	5
6	PIN, 3/8" X 2" ROLL	F05012-42	2
7	BOLT, 3/8-16 X 3/4" HEX HEAD GRADE 2	F05007-27	4
8	WASHER, 3/8" SPLIT LOCK	F050011-4	4
9	BAG, TENSIONER AIR	033229	1
10	FITTING, 1/4" NPT X 1/4" AIR 90 ELBOW	P21519	2
11	BOLT, 3/8-16 X 1" HEX HEAD GRADE 5	F05007-87	2
12	BAG, MOTOR LIFT AIR	033231	1

3 Blade Wheels & Tensioner

Blade Motor Drive Assembly

13	COVER, BELT	036662	1	
14	BOLT, 1/4-20 X 1/2" HEX HEAD	F05005-15	5	
15	WASHER, 1/4" SAE FLAT	F05011-11	5	
16	BOLT, 1/4-20 X 3/4" HEX HEAD	F05005-129	5	
17	NUT, 1/4-20 SELF-LOCKING HEX	F05010-9	7	
18	CLAMP, 1" EMT	P05436	2	
19	BOLT, 1/4-20 X 3/4" HEX HEAD FULL THREAD	F05005-1	2	
20	BEARING, MOTOR PIVOT	033210	2	
21	PLATE, PIVOT BOLT LOCK	033230	1	
22	BOLT WELDMENT, MOTOR PIVOT	033225	1	
23	WASHER, 5/16" SPLIT LOCK	F05011-13	1	
24	BOLT, 5/16-18 X 3/4" HEX HEAD	F05006-5	1	
25	WASHER, 5/16" SPLIT LOCK	F05011-13	9	
26	BOLT, 5/16-18 X 1" HEX HEAD GRADE 5	F05006-48	9	
	DRIVE ASSEMBLY, 30HP 480V/60HZ PD			
	DRIVE ASSEMBLY, 30HP 480V/50HZ PD			
27	Plate Weldment, Motor Mount	042461	1	
28	Washer, .52" ID x 1.69" OD	014632	4	
29	Bolt, 1/2-13 x 2" Hex Head	F05008-76	4	
30	Bolt, 1/2-13 x 4 1/2" Hex Head Full THread	F05008-16	2	
31	Nut, 1/2-13 Hex	F05010-35	4	
32	Washer, 1/2" Split Lock	F05011-9	2	
33	Bolt, 1/2-13 x 2" Hex Head Full Thread	F05008-8	1	
34	Nut, 1/2-13 Hex Jam	F05010-31	2	
35	Washer, 3/8" Split Lock	F05011-4	4	
36	Bolt, 3/8-16 x 3/4" Hex Head Grade 2	F05007-27	4	
37	Bolt, 3/8-16 x 1" Flat Socket Head	F05007-64	2	
38	Nut, 1/2-13 Hex Nylon Lock	F05010-8	4	
39	Motor, Sg 180L-4 22 kW	092610	1	
40	Belt, Eagle PD G2380	036636	1	
41	Pulley, Eagle PD G36SSF	036634	1	
	Pulley, Eagle PD G45SE (50Hz)	036635	1	
42	Bushing, E x 1 7/8" (50Hz)	036709	1	
43	Cover Weldment, Belt Guard	036678	1	
44	BOLT, 1/2-13 X 2" HEX HEAD FULL THREAD	F05008-8	1	
45	NUT, 1/2-13 HEX JAM	F05010-31	1	

SECTION 4 SAW HEAD

4.1 Board Return

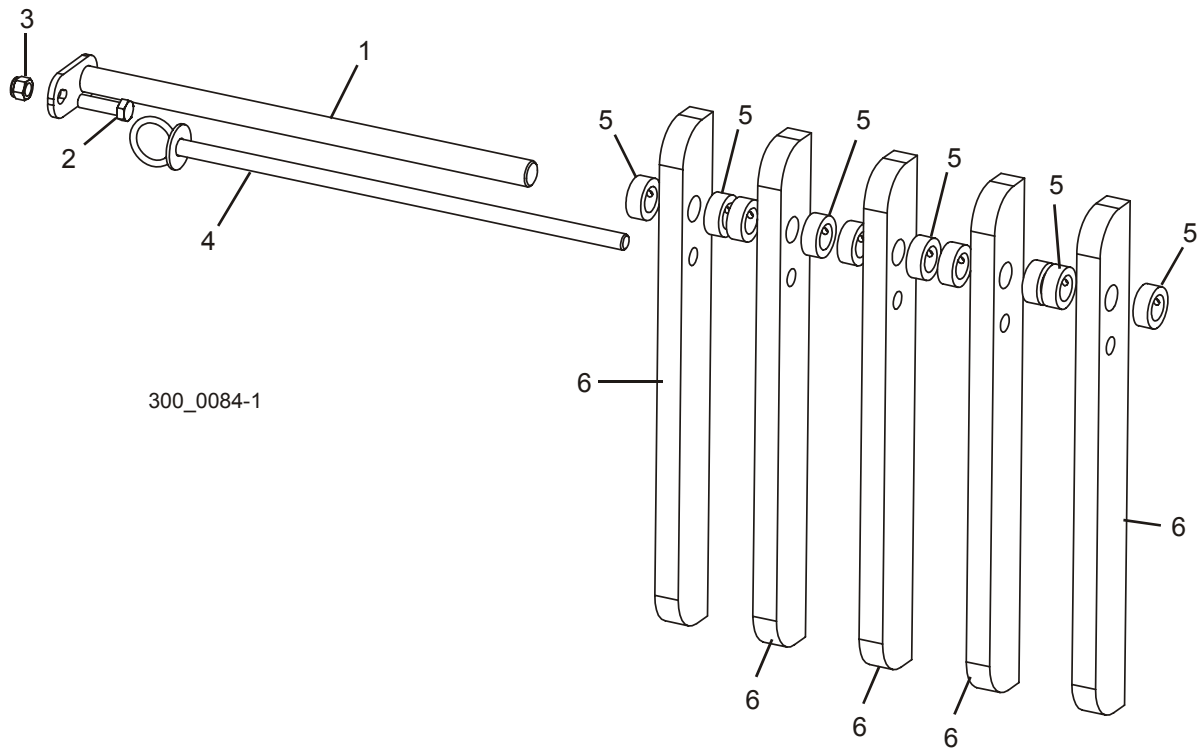

REF	DESCRIPTION (◆ Indicates Parts Available In Assemblies Only)	PART #	QTY.
1	PIN WELDMENT, BOARD RETURN PIVOT	042167	1
2	BOLT, 1/2-13 X 1 3/4" HEX HEAD GRADE 5	F05008-88	1
3	NUT, 1/2-13 HEX NYLON LOCK	F05010-8	1
4	PIN WELDMENT, SUPPORT	042168	1
5	COLLAR, 1" LOCK	038090	10
6	ARM, BOARD RETURN	036464	5

4 Saw Head Board Return Guide

4.2 Board Return Guide

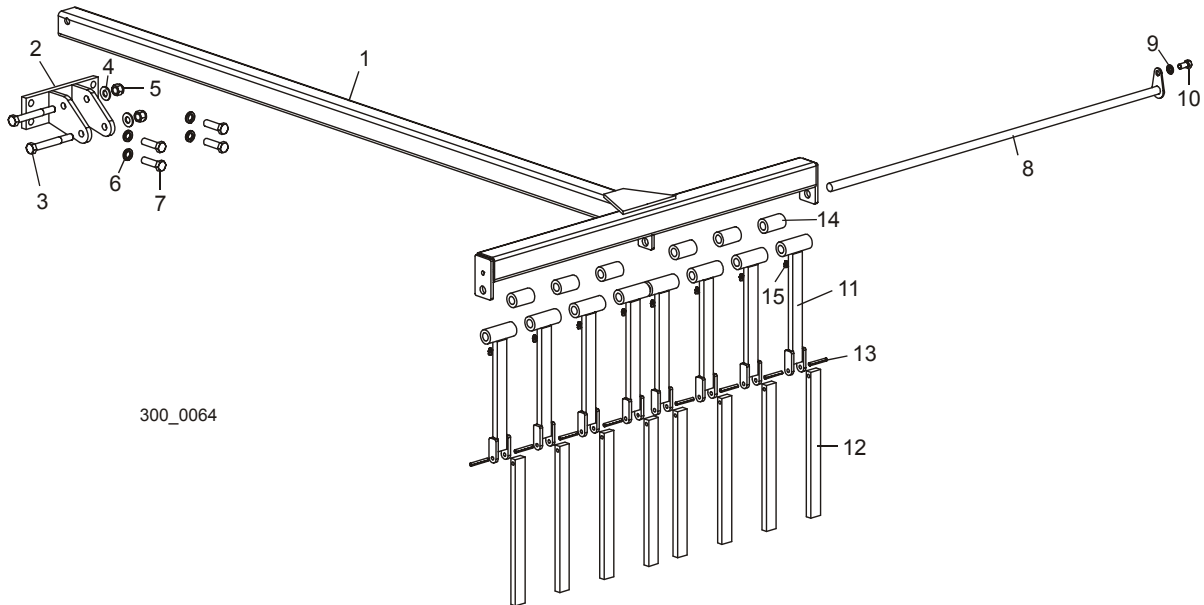

300_0064

REF	DESCRIPTION (◆ Indicates Parts Available In Assemblies Only)	PART #	QTY.
	GUIDE ASSEMBLY, BOARD RETURN	017808	1
1	Guide Weldment, Board Return	017809	1
2	Bracket Weldment, Board Return Guide Mount	017811	1
3	Bolt, 1/2-13 x 4" Hex Head	F05008-26	2
4	Washer, 1/2" SAE Flat	F05011-2	2
5	Nut, 1/2-13 Hex Nylon Lock	F05010-8	2
6	Washer, 1/2" Split Lock	F05011-9	4
7	Bolt, 1/2-13 1 3/4" Hex Head Grade 5	F05008-88	4
8	Rod Weldment, Board Return Guide	034408	1
9	Washer, 3/8" Split Lock	F05011-4	1
10	Bolt, 3/8-16 x 3/4" Hex Head Grade 5	F05007-118	1
11	Bar Weldment, Board Guide Upper	017823	8
12	Bar, Board Guide Lower	017822	8
13	Pin, 1/4" x 1 3/4" Roll	F05012-53	8
14	Tube, Board Guide Spacer	017820	6
15	Fitting, 3/16" x 3/16" Straight Grease	P04107	8

4.3 Covers & Sawdust Chute

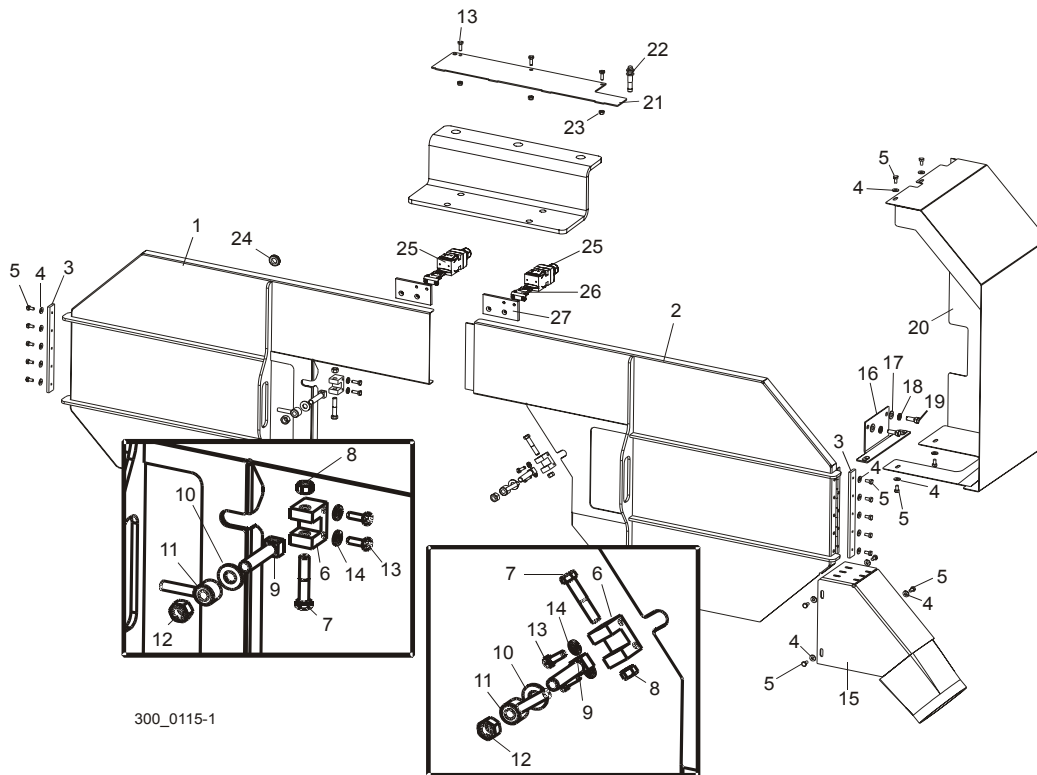

300_0115-1

REF	DESCRIPTION (◆ Indicates Parts Available In Assemblies Only)	PART #	QTY.
1	COVER WELDMENT, IDLE SIDE BLADE HOUSING	042341	1
2	COVER WELDMENT, DRIVE SIDE BLADE HOUSING	042340	1
3	PLATE, COVER MOUNT	042435	2
4	WASHER, 1/4" SAE FLAT	F05011-11	18
5	BOLT, 1/4-20 X 1/2" HEX HEAD	F05005-15	18
	LATCH ASSEMBLY, BLADE HOUSING COVER	042440	2
6	Block, Cover Latch	042439	1
7	Bolt, 3/8-16 x 2" Hex Head	F05007-72	1
8	Nut, 3/8-16 Hex Lock	F05010-25	1
9	Bolt, Cover Latch	042438	1
10	Washer, 1/2" SAE Flat	F05011-2	1
11	Handle Weldment, Cover Latch	021145	1
12	Nut, 1/2-13 Hex Lock	F05010-3	1
13	BOLT, 1/4-20 X 3/4" HEX HEAD FULL THREAD	F05005-1	7
14	WASHER, 1/4" SPLIT LOCK	F05011-14	4
15	CHUTE WELDMENT, SAWDUST	045005	1
16	BRACKET WELDMENT, SIDE GUARD MOUNT	036847	1
17	WASHER, 3/8" SAE FLAT	F05011-3	2

4**Saw Head**
Covers & Sawdust Chute

18	WASHER, 3/8" SPLIT LOCK	F05011-4	2	
19	BOLT, 3/8-16 X 1" HEX HEAD GRADE 5	F05007-87	2	
20	GUARD WELDMENT, SIDE	036845	1	
21	PLATE, BOTTOM SAW HEAD WIREWAY	042252	1	
22	SENSOR, BES M12MI-PSH80B S04G PROXY	093168	1	
23	NUT, 1/4-20 HEX SELF-LOCKING	F05010-9	3	
24	GROMMET, 5/8" ID RUBBER	P11764	1	
25	SAFETY SWITCH	094232	2	
26	SAFETY SWITCH KEY	094422	2	
27	SAFETY SWITCH BRACKET	097125	2	
28	SAFETY SWITCHES MOUNT	098584-1	1	

4.4 Blow-Off Assembly

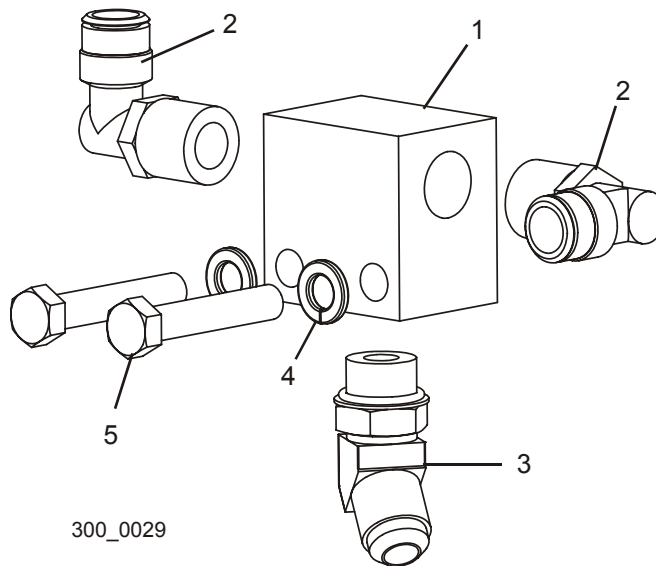

REF	DESCRIPTION (◆ Indicates Parts Available In Assemblies Only)	PART #	QTY.
	BLOCK ASSEMBLY, BLOW-OFF	016882	1
1	Block, Blow-Off	016879	1
2	Fitting, 1/2" NPT x 1/2" Tube 90° Swivel Elbow	016880	1
3	Fitting, #8 JIC x #8 SAE 45° Elbow	041161	1
4	Fitting, 1/2" NPT x 1/2" Hose Barb 90° Elbow	015997	1
5	Washer, 3/8" Split Lock	F05011-4	2
6	Bolt, 3/8-16 x 2" Hex Head Full Thread	F05007-16	2
	TUBING, 1/2" AIR LINE	R01869-2	62 Ft.
	TUBING, 1/2" AIR LINE	R01869-2	4 Ft.

4 Saw Head

Laser Assembly

4.5 Laser Assembly

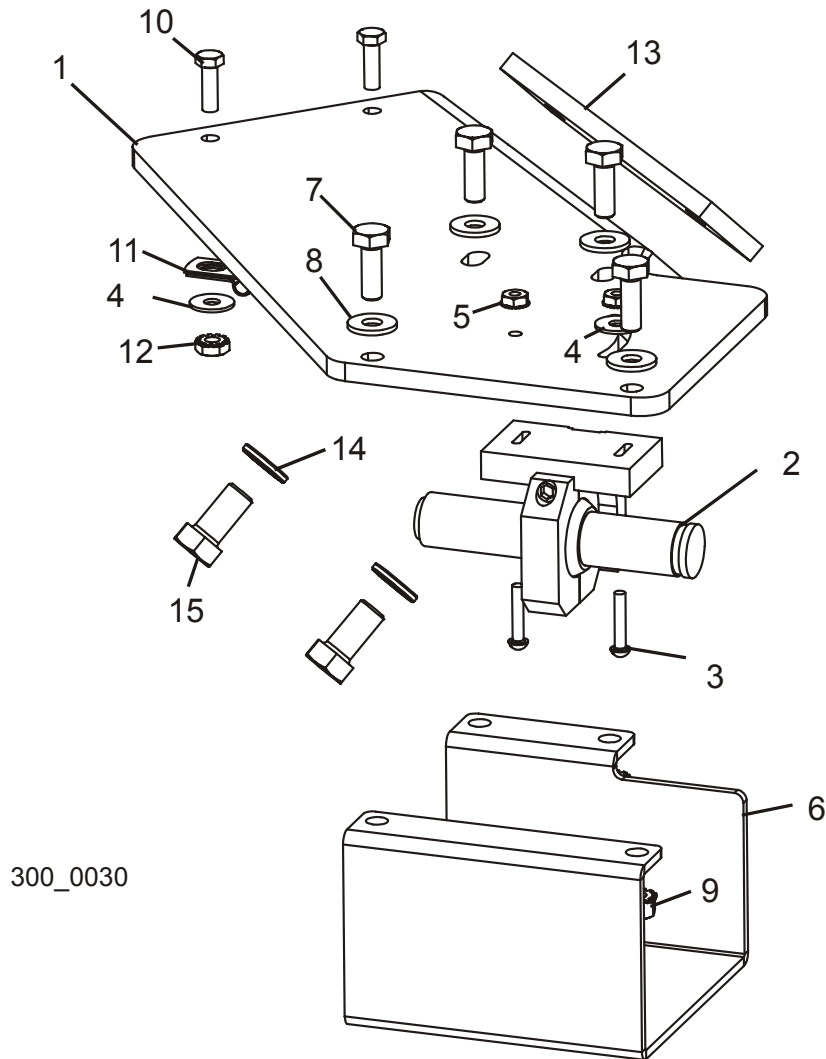

REF	DESCRIPTION (◆ Indicates Parts Available In Assemblies Only)	PART #	QTY.
	LASER ASSEMBLY, LT300	042169	1
1	Plate, Laser Mount	042744	1
2	Laser, 15mW 635nm 60° Line w/Mounting Bracket	025125	1
3	Screw, #6-32 x 3/4" Slotted Round Head	F05004-21	2
4	Washer, #10 SAE Flat	F05011-18	3
5	Nut, #6 Hex Self-Locking	F05010-59	2
6	Cover, Laser Guard	042743	1
7	Bolt, 1/4-20 x 3/4" Hex Head Full Thread	F05005-1	4
8	Washer, 1/4" SAE Flat	F05011-11	4
9	Nut, 1/4-20 Hex Self-Locking	F05010-9	4

10	Bolt, #10-24 x 5/8" Hex Head	F05004-18	2	
11	Clamp, .187 Cushioned Metal Cable	025196	2	
12	Nut, #10-24 Hex Self-Locking	F05010-14	2	
13	Plate, Laser Mount Nut	042452	1	
14	Washer, 3/8" Split Lock	F05011-4	2	
15	Bolt, 3/8-16 x 3/4" Hex Head Grade 2	F05007-27	2	

4 Saw Head

Decals, LT300

4.6 Decals, LT300

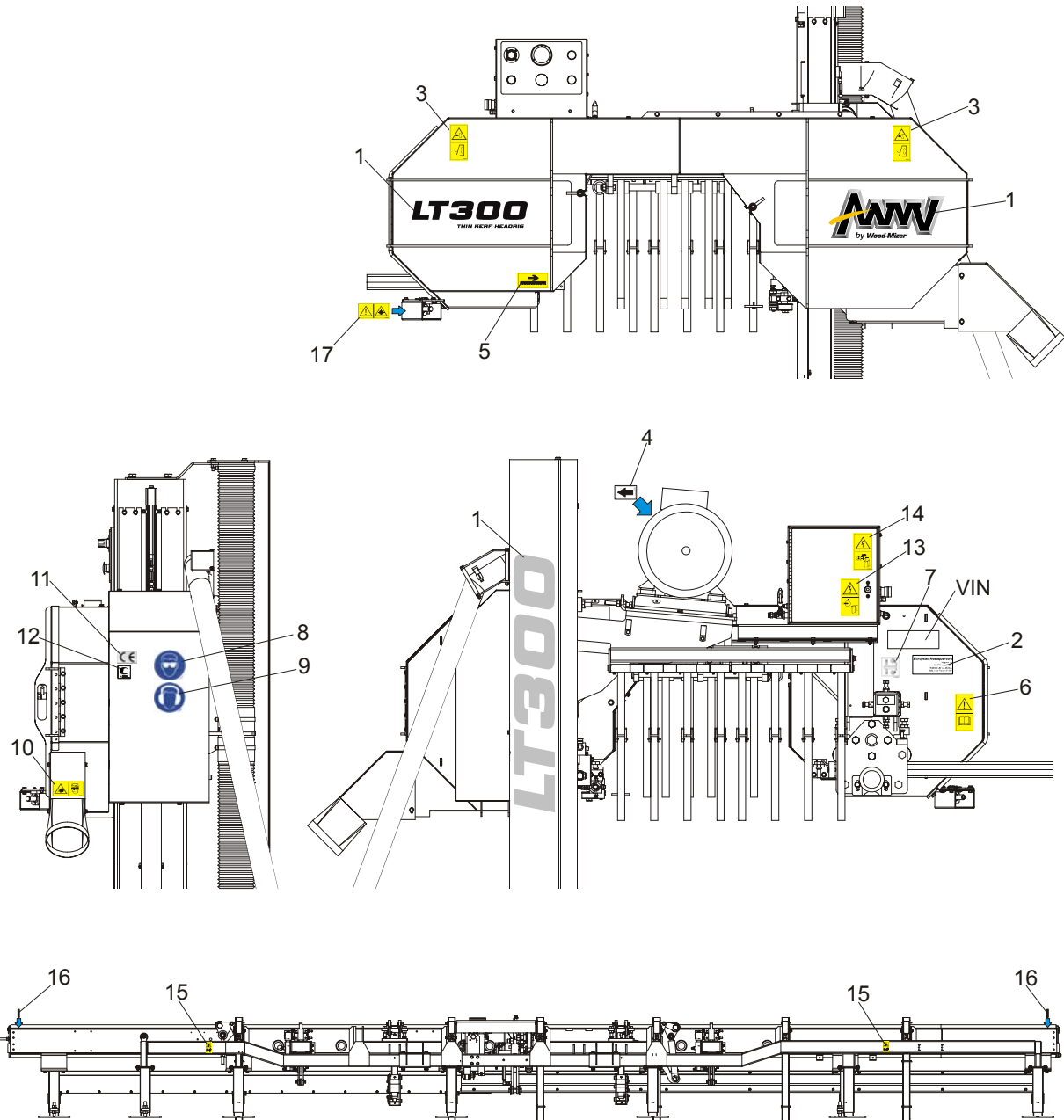

REF	DESCRIPTION (◆ Indicates Parts Available In Assemblies Only)	PART #	QTY.
1	DECAL KIT, LT300 SAWMILL NAME	099589	1
	DECAL KIT, LT300 PICTOGRAMS	101136	1
2	DECAL, EUROPEAN HEADQUARTERS ADDRESS	015841	1

3	DECAL, SAWMILL COVERS CAUTION	099220	2	
4	DECAL, MOTOR ROTATION DIRECTION - 1465 RPM	S200971	1	
5	DECAL, BLADE MOVEMENT DIRECTION (PICTOGRAM)	096321	1	
6	DECAL, READ OPERATOR'S MANUAL (PICTOGRAM)	096317	1	
7	DECAL, BLADE ALIGNMENT	P11789	1	
8	DECAL, SAWDUST CHUTE WARNING (PICTOGRAM)	099222	1	
9	DECAL, EYE PROTECTION WARNING (PICTOGRAM)	S12004G	1	
10	DECAL, EAR PROTECTION WARNING (PICTOGRAM)	S12005G	1	
11	DECAL, CE CERTIFIED SAWMILL	P85070	1	
12	DECAL, RUSSIAN SAFETY CERTIFICATION	099401	1	
13	DECAL, HIGH VOLTAGE INSIDE THE ELECTRIC BOX (PICTOGRAM)	096316	1	
14	DECAL, REMOVE THE PLUG BEFORE OPENING THE BOX (PICTOGRAM)	096319	1	
15	DECAL , KEEP AWAY DANGER, PICTOGRAM	099221	1	
16	DECAL, LOG LENGTH LIMIT	S12051	1	
17	DECAL, WARNING - LASER BEAM, PICTOGRAM	099504	1	
	DECAL, KEEP AWAY FROM DEBARKER BLADE, PICTOGRAM	098176	1	
	DECAL, WARNING LOG LOADER ARM, PICTOGRAM	099545	1	

4 Saw Head

Decals, Operator Station

4.7 Decals, Operator Station

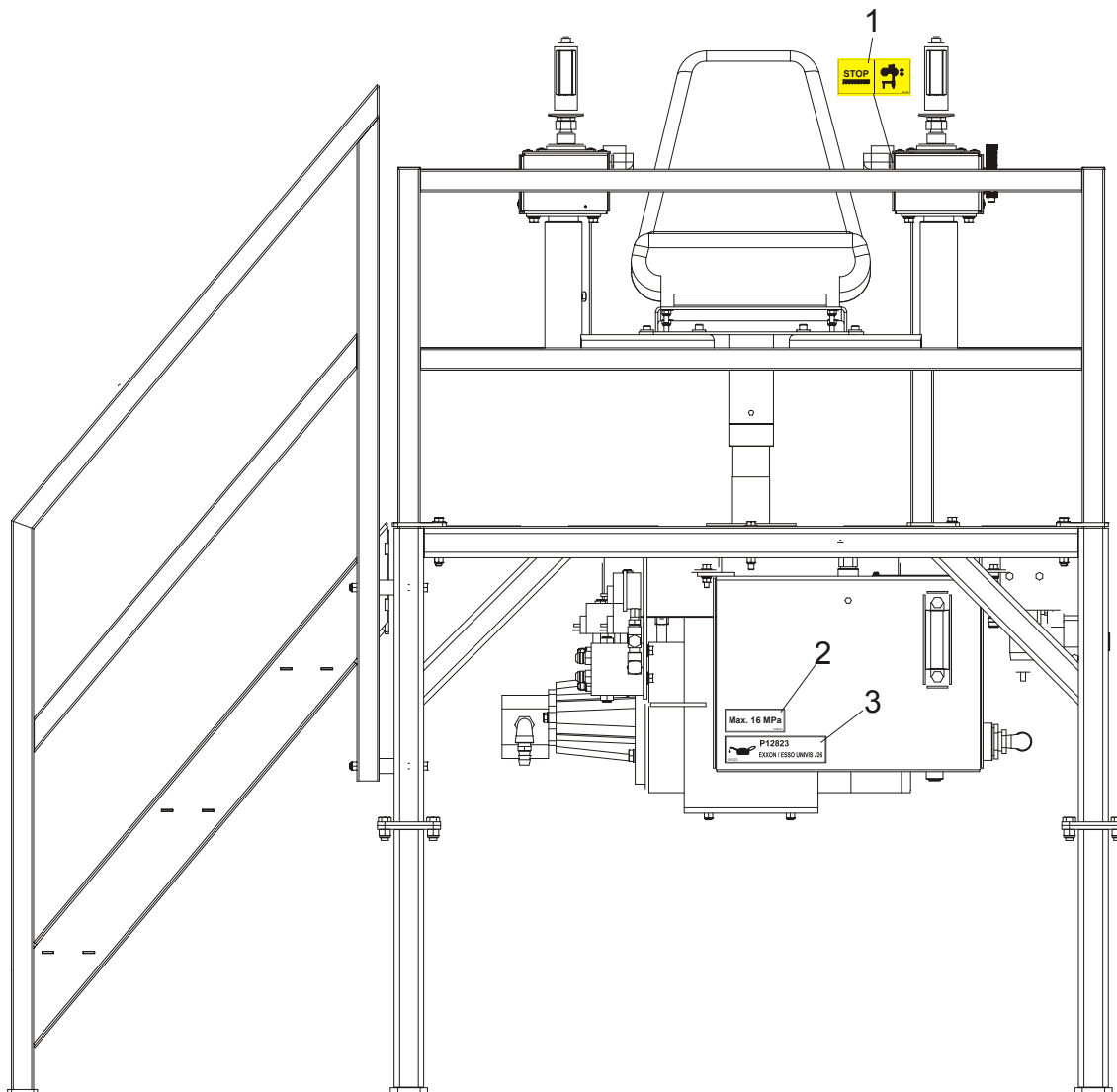

REF	DESCRIPTION (◆ Indicates Parts Available In Assemblies Only)	PART #	QTY.
1	Decal, Stop Blade Before Aligning Head Up/Down, Pictogram	101138	1
2	Decal, Max. Oil Pressure	099524	1
3	Decal, Hydraulic Oil	096323	1

4.8 Head/Air Box Control Assembly

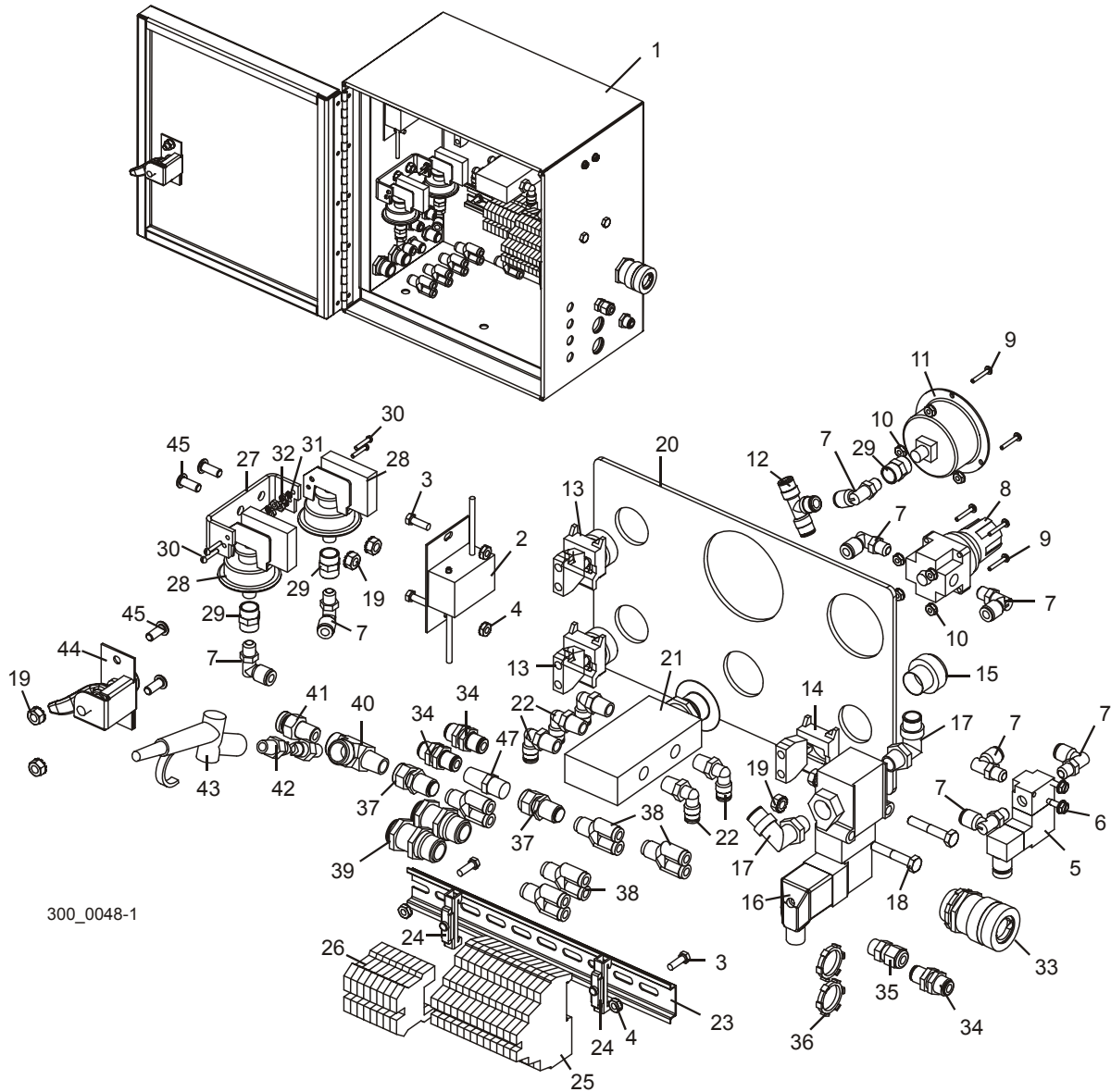

300_0048-1

REF	DESCRIPTION (◆ Indicates Parts Available In Assemblies Only)	PART #	QTY.
	CONTROL ASSEMBLY, HEAD/AIR BOX	045244	1
1	Box Weldment, Head/Air	035569	1
2	Power Supply, 10-24V Laser	052327	1
3	Screw, #10-24 x 5/8" Unslotted Indent Hex Head	F05004-18	4
4	Nut, #10-24 Hex Self-Locking	F05010-14	4
5	Valve, Air 3-Way 1/8" NPT DIN C Conn	045225	1
	Cable, 10M Form C DIN 24VDC w/LED	025233	1

4

Saw Head

Head/Air Box Control Assembly

6	Screw, #10-24 x 1/2" Self-Tapping Slotted Hex	F05015-7	2	
7	Fitting, 1/8" MPT x 1/4" Tube Swivel Elbow	P09736	8	
8	Regulator, Air	045247	1	
	Regulator, 1/8" NPT Air	052509	1	
	Nut, Regulator Mount	052510	1	
9	Screw, #6-32 x 3/4" Socket Button Head Stainless	F05004-93	7	
10	Nut, #6-32 Hex Self-Locking	F05010-59	7	
11	Gauge, Air Pressure	042342	1	
12	Fitting, 1/4" Tube 'T'	P21544	1	
13	Light, Yellow 24V 22mm LED XB4 Pilot	024970-5	2	
14	Switch, 1NO 22mm XB4	025242	1	
15	Button, 22mm Mom Ext LED Yellow XB4 Switch	025237-53	1	
16	Valve Assembly, Blow-Off	042659	1	
	Cable, 5M Form A DIN 24VDC w/LED	024923	1	
17	Fitting, 3/8" NPT x 1/2" Tube Swivel Elbow	034009	2	
18	Bolt, 1/4-20 x 1 1/2" Hex Head Full Thread	F05005-31	2	
19	Nut, 1/4-20 Hex Self-Locking	F05010-9	6	
20	Decal, Head/Air Control Box	052274	1	
21	Valve, 4-Way Push/Pull 1/4" NPT	025301	1	
22	Fitting, 1/4" NPT x 1/4" Tube Elbow	P21519	5	
23	DIN Rail, 35mm x 7.5mm x 10" Steel Sym	024474-10	1	
24	Clamp, Metal DIN Rail	E22707	2	
25	Terminal Block, 3-Tier	024908	13	
26	Terminal Block, 1-Tier	024893	8	
27	Bracket, Pressure Switch Mount	042256	1	
28	Switch, Limit Pressure 60 PSI	045207	2	
29	Fitting, 1/8" FPT Coupling	P05748	3	
30	Screw, #4-40 x 5/8" Slotted Round Head	F05004-49	4	
31	Washer, #4 Split Lock	F05011-21	4	
32	Nut, #4 Hex	F05010-43	4	
33	Connector, .75 Hole x .63-.75 Cord Flex Strain	025186	1	
	Nut, 3/4" Conduit Lock	025198	1	
34	Fitting, 1/4" x 1/4" Tube Bulkhead	025234	1	
35	Connector, .5" Hole .064-.210 Cord	E23494	1	
36	Nut, 1/2" Conduit Lock	E20461	2	
37	Fitting, 1/4" Tube x 1/4" NPT Female Bulkhead	025235	2	
38	Fitting, 1/4" Tube "Y"	042546	5	
39	Fitting, 3/8" NPT x 1/2" Tube Bulkhead	034010	2	
40	Fitting, 1/4" Male Run Tee	P09141	1	
41	Fitting, 1/4" NPT x 3/8" Tube	P21559	1	
42	Hose, 1/4" x 6' Coiled Air	042453	1	
43	Nozzle, Air Spray	P02714	1	
44	Latch, Door	P20048	1	

45	Screw, 1/4-20 x 5/8" Button Socket Head	F05005-128	4	
	Harness Assembly, LT300 Blade Guide	025284	1	
	Harness Assembly, LT300 Motor Prox	025286	1	
	Harness Assembly, LT300 Start Prox	025287	1	
	Harness Assembly, LT300 Slow Prox	025288	1	
	Harness Assembly, LT300 Stop Prox	025289	1	
	Hose, 1/4" Air	R01869	186"	
	Hose, 1/2" Air	R01869-2	58"	
	Cable, LT300 Oiler	025233	1	

SECTION 5 UP/DOWN SYSTEM

5.1 Mast Pads & Rollers

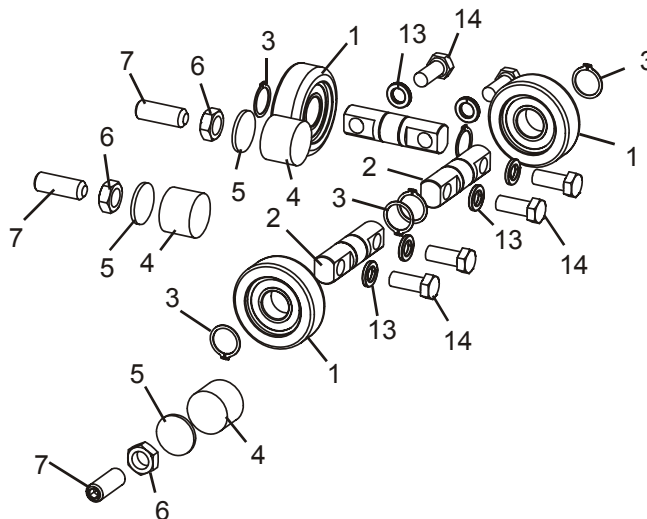

300_0028-4

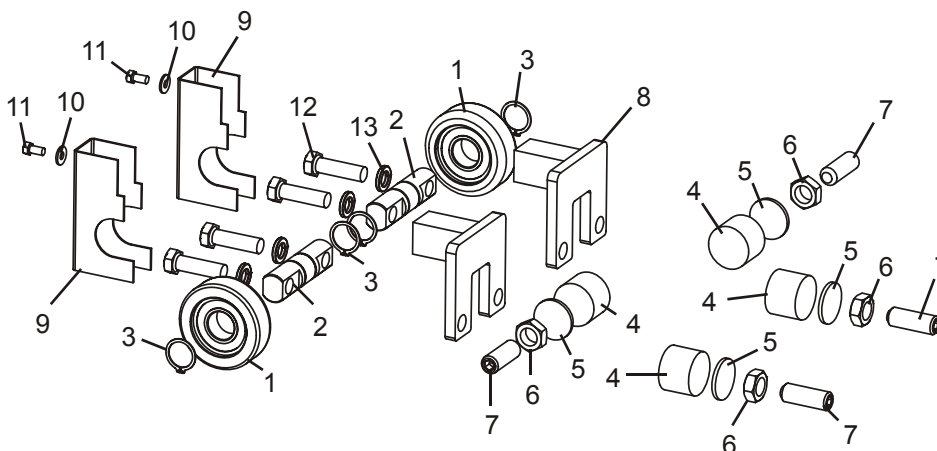

REF	DESCRIPTION (◆ Indicates Parts Available In Assemblies Only)	PART #	QTY.	
	BEARING ASSEMBLY, UP/DOWN MAST	023832	5	
1	Bearing, MG305DDA	023857	1	◆
2	Shaft, Up/Down Mast Bearing	023858	1	
3	Ring, 1" Outside Retaining	F04254-15	2	
4	PAD, ROUND NYLON	033098	7	
5	PAD, NYLON BACKING	042432	7	
6	NUT, 5/8-18 HEX JAM	F05010-11	7	
7	SCREW, 5/8-18 X 1 3/4" SOCKET HEAD FLAT POINT SET	F05009-27	7	
8	BRACKET WELDMENT, UP/DOWN BEARING MOUNT	045048	2	

9	COVER, MAST BEARING	045047	2	
10	WASHER, 1/4" SAE FLAT	F05011-11	2	
11	BOLT, 1/4-20 X 1/2" HEX HEAD	F05005-15	2	
12	BOLT, 1/2-13 X 1 3/4" HEX HEAD GRADE 5	F05008-88	4	
13	WASHER, 1/2" SPLIT LOCK	F05011-9	10	
14	BOLT, 1/2-13 X 1 1/4" HEX HEAD GRADE 5	F05008-37	6	

5.2 Bearing Rails

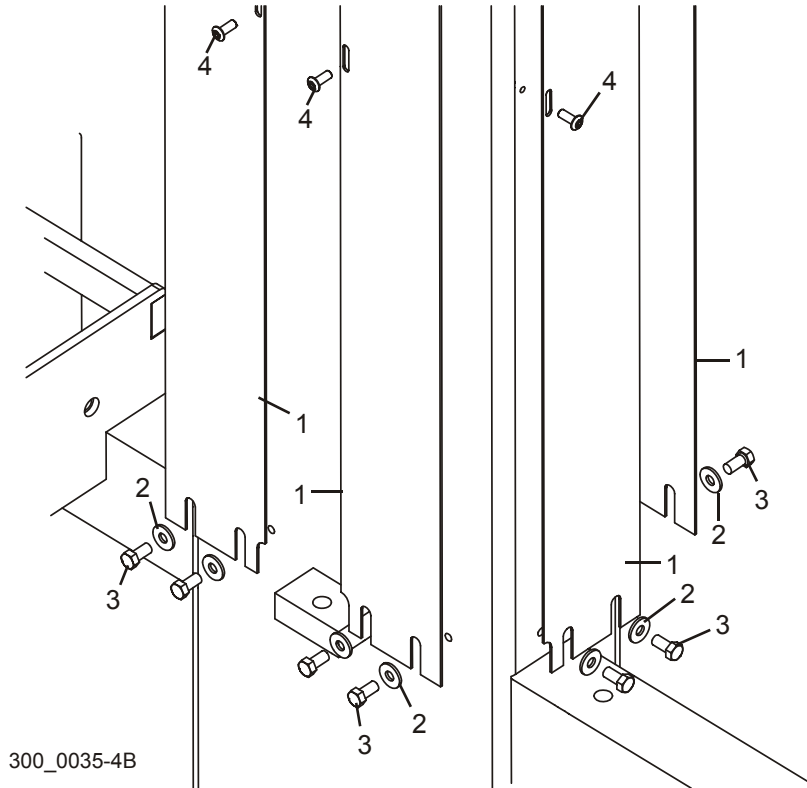

REF	DESCRIPTION (◆ Indicates Parts Available In Assemblies Only)	PART #	QTY.
	RAIL KIT, UP/DOWN BEARING	042788	1
1	Rail, Up/Down Bearing	042773	6
2	Washer, 1/4" SAE Flat	F05011-11	24
3	Bolt, 1/4-20 x 1/2" Hex Head	F05005-15	24
4	Screw, #10-24 x 1/2" Button Socket Head	F05004-35	18

5.3 Up/Down Ballscrew Drive

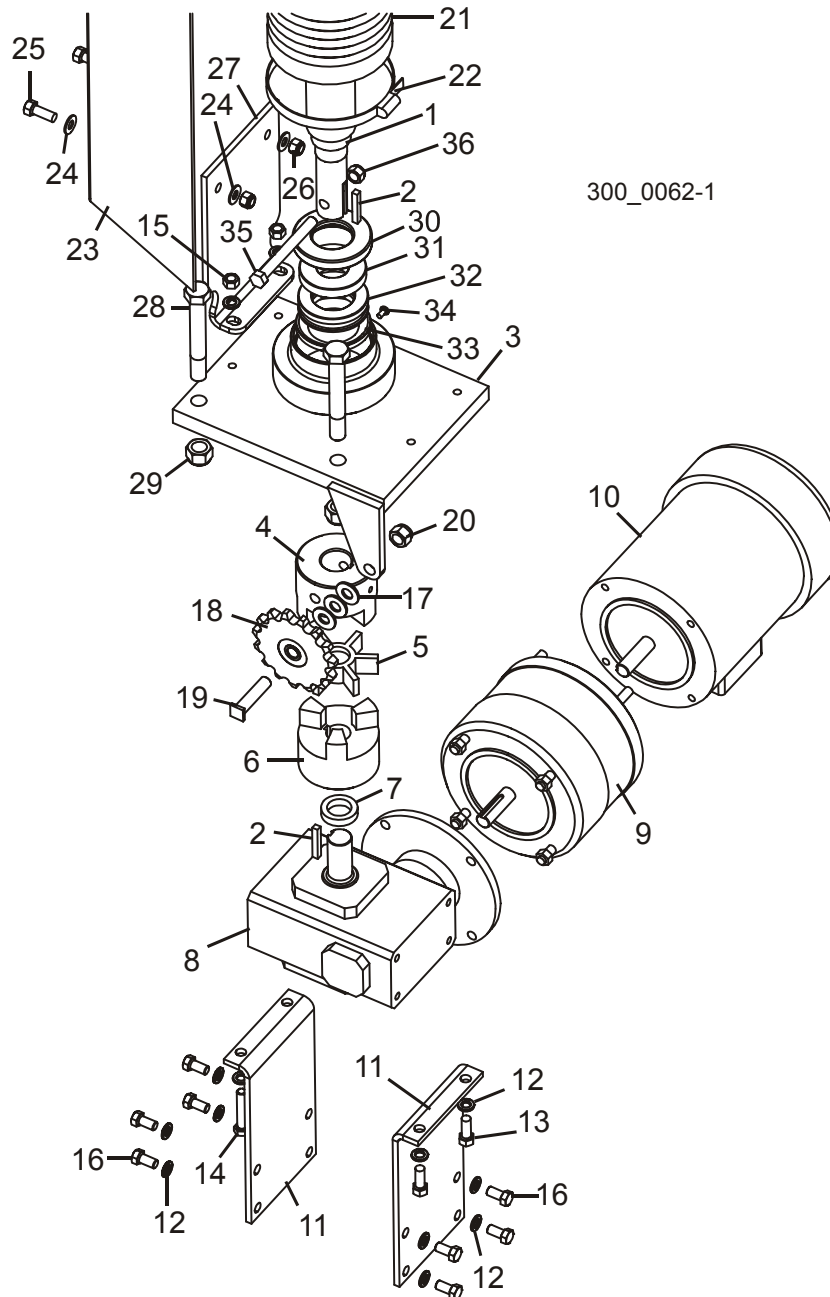

REF	DESCRIPTION (◆ Indicates Parts Available In Assemblies Only)	PART #	QTY.
	GREASE, 10CC SYRINGE UP/DOWN BALLSCREW	042399	1
	DRIVE ASSEMBLY, BALLSCREW UP/DOWN	042800	1
1	Shaft, 2" x .5" Ballscrew	042858	1
2	Key, 1/4" Square x 1 5/8"	042810	2

5 Up/Down System

Up/Down Ballscrew Drive

3	Bracket Weldment, Up/Down 45mm Ballscrew Mount	017790	1	
4	Coupling, Modified L110 x 1 1/4" Body	017787	1	
5	Coupling, L110 Spider	042809	1	
6	Coupling, L110 x 1" Body	042820	1	
7	Spacer, 1" ID x 1 1/2" OD x .25" Thick	042805 ¹	1	
8	Gearbox, Up/Down Ballscrew IC60	042793	1	
9	Brake, Up/Down Electric 5/8-5/8 230/460V	042281	1	
10	Motor, 2HP 3PH 230/460V REFC 56C	042390	1	
11	Plate, Up/Down Gearbox Mount	042794	2	
12	Washer, 3/8" Split Lock	F05011-4	14	
13	Bolt, 3/8-16 x 1" Hex Head	F05007-7	2	
14	Bolt, 3/8-16 x 2" Hex Head Full Thread	F05007-16	2	
15	Nut, 3/8-16 Hex	F05010-1	2	
16	Bolt, 3/8-16 x 3/4" Hex Head	F05007-27	8	
17	Washer, 1/2" SAE Flat	F05011-2	3	
18	Sprocket, Idler	042367	1	
19	Shaft, Idler Sprocket	016828	1	
20	Nut, 1/2-13 Hex Nylon Lock	F05010-8	1	
21	Bellows, 5" ID x 45" Ballscrew Protective	017777	1	
22	Clamp, Bellows Worm	042419	1	
	Guard Assembly, Up/Down Bellows	042416	1	
23	Guard Weldment, Up/Down Bellows	017647	1	
24	Washer, 3/8" SAE Flat	F05011-3	4	
25	Bolt, 3/8-16 x 1" Hex Head	F05007-7	2	
26	Nut, 3/8-16 Hex Nylon Lock	F05010-10	2	
27	Plate, Bellows Guard Bottom	042417	1	
28	Bolt, 5/8-11 x 4 1/2" Hex Head Grade 5	F05009-10	2	
29	Nut, 5/8-11 Hex Nylon Lock	F05010-34	2	
30	Seal, 1 5/8" ID Thrust Bearing	042857	1	
31	Spacer, Screw/Bearing Support	042856	1	
32	Bearing, 45mm Self-Aligning Thrust Cone	042855-1	1	
33	Bearing, 45mm Self-Aligning Thrust Cup	042855-2	1	
34	Screw, #10-24 x 3/8" Phillips Pan Head	F05004-3	1	
35	Bolt, 7/16-14 x 4" Hex Head	F05007-180	1	
36	Nut, 7/16-14 Hex Nylon Lock	F05010-135	1	
	Middle Ballscrew Mount Parts (See Section 5.4)			
	Top Ballscrew Mount Parts (See Section 5.5)			

¹ 042805 spacer replaces 017778 .35" spacer originally supplied before 4/03. Thinner spacer provides proper clearance between gearbox and coupler.

5.4 Ballscrew Mount (Middle)

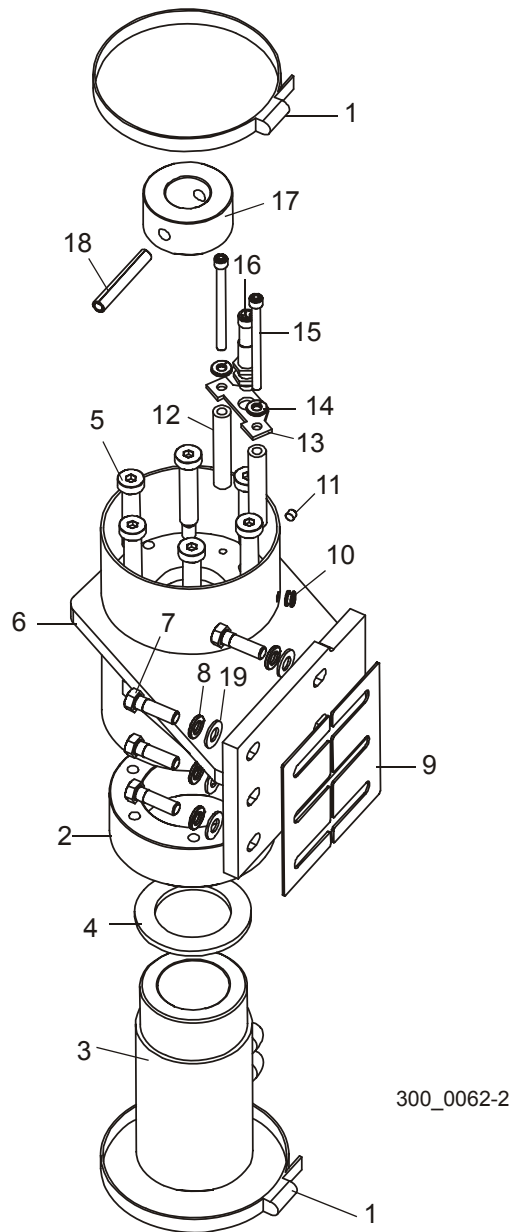

REF	DESCRIPTION (◆ Indicates Parts Available In Assemblies Only)	PART #	QTY.
1	CLAMP, BALLSCREW BELLOWS	042419	2
	BALLSCREW ASSY, UP/DOWN SERVICE	036595	1
	Ballscrew Kit, Up/Down w/Nut	036596	1
	Shaft, 2" x .5" Ballscrew (Shown in Section 5.3)	042858	1
2	Nut, 2" BallScrew	042791	1
	Grease, 10cc Syringe Up/Down Ballscrew	042399	1

5 Up/Down System

Ballscrew Mount (Middle)

Lower Ballscrew Mount Parts (See Section 5.3)				
3	Flange, 2" BallScrew Nut	042792	1	
4	Plate, BallScrew Nut Wear	042816	1	
5	Bolt, 1/2" x 2 1/4" Shoulder	F05008-136	6	
6	Bracket Weldment, Middle Ballscrew Mount	042819	1	
7	Bolt, 3/8-16 x 1 1/4" Hex Head Grade 5	F05007-123	6	
8	Washer, 3/8" Split Lock	F05011-4	6	
9	Plate, Ballscrew Mount Shim	016800	2	
10	Grommet, 9/32" Hole x 3/16" ID x 7/16" OD	042825	1	
11	Screw, 1/4-28 x 1/4" Brass Tip Socket Set	F05005-42	1	
12	Spacer, 17/64" ID x 1/2" OD x 2 3/4" Long	042821	2	
13	Plate, BallScrew Sensor Mount	042815	1	
14	Washer. 1/4" Split Lock	F05011-14	2	
15	Bolt, 1/4-20 x 3 1/4" Socket head	F05005-154	2	
16	Sensor, BES M12MI-PSH80B S04G Proxy	093168	1	
17	Collar, Ballscrew Nut Stop	042822	1	
18	Pin, 3/8" x 2 1/2" Roll	F05012-114	1	

5.5 Ballscrew Mount (Top)

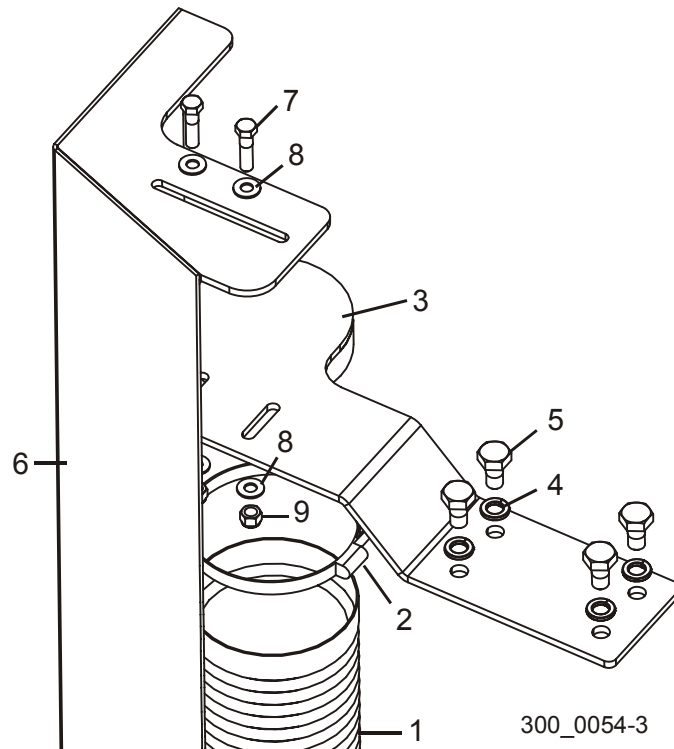

REF	DESCRIPTION (◆ Indicates Parts Available In Assemblies Only)	PART #	QTY.	
1	BELLOWS, 5" ID X 62" BALLSCREW PROTECTIVE	042823	1	
2	CLAMP, BALLSCREW BELLOWS	042419	1	
3	MOUNT WELDMENT, TOP BELLOWS	042814	1	
4	WASHER, 1/2" SPLIT LOCK	F05011-9	4	
5	BOLT, 1/2-13 X 1" HEX HEAD	F05008-50	4	
6	GUARD PARTS (See Section 5.3)			
7	BOLT, 3/8-16 X 1 1/2" HEX HEAD	F05007-3	2	
8	WASHER, 3/8" SAE FLAT	F05011-3	4	
9	NUT, 3/8-16 HEX NYLON LOCK	F05010-10	2	

5.6 Transducer & Head Stop

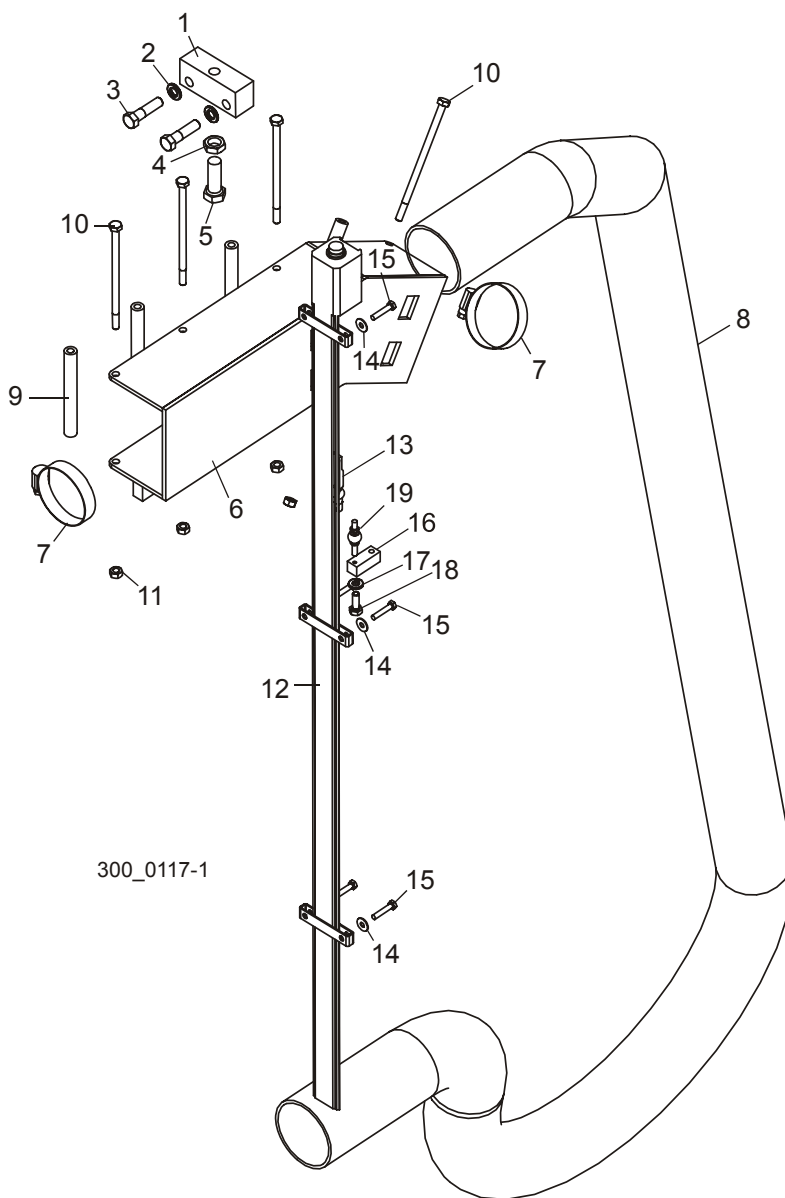

REF	DESCRIPTION (◆ Indicates Parts Available In Assemblies Only)	PART #	QTY.
1	BLOCK, HEAD STOP	023886	1
2	WASHER, 3/8" SPLIT LOCK	F05011-4	5
3	BOLT, 3/8-16 X 1 1/2 HEX HEAD GRADE 5	F05007-78	5
4	NUT, 1/2-13 HEX JAM	F05010-31	1
5	BOLT, 1/2-13 X 1 1/2" HEX HEAD GRADE 5	F05008-33	1
6	BRACKET WELDMENT, TOP WIREWAY	042148	1

7	CLAMP, 2" WORM	P11633	2	
8	SLEEVE, WIRE HARNESS	042422	1	
9	SPACER, WIREWAY	042111	4	
10	BOLT, 1/4-20 X 5" HEX HEAD	F05005-146	4	
11	NUT, 1/4-20 HEX LOCK	F05010-21	4	
12	SENSOR, 36" 4-20MA CAPTIVE SLIDE TRANSDUCER	025042	1	
13	Magnet, Captive Sliding Transducer (Balluff)	052470	1	
	CABLE ASSEMBLY, LT300 TRANSDUCER SENSOR	050974	1	
14	WASHER, #10 SAE FLAT	F05011-18	6	
15	BOLT, #10-24 X 1" UNSLOTTED HEX HEAD	F05004-156	6	
16	BLOCK, TRANSDUCER SLIDE	042436	1	
17	WASHER, 1/4" SPLIT LOCK	F05011-14	1	
18	BOLT, 1/4-20 X 3/4" HEX HEAD FULL THREAD	F05005-1	1	
19	PIVOT, BALL JOINTED ARM	025197	1	

SECTION 6 POWER FEED

6.1 Upper Track Rollers

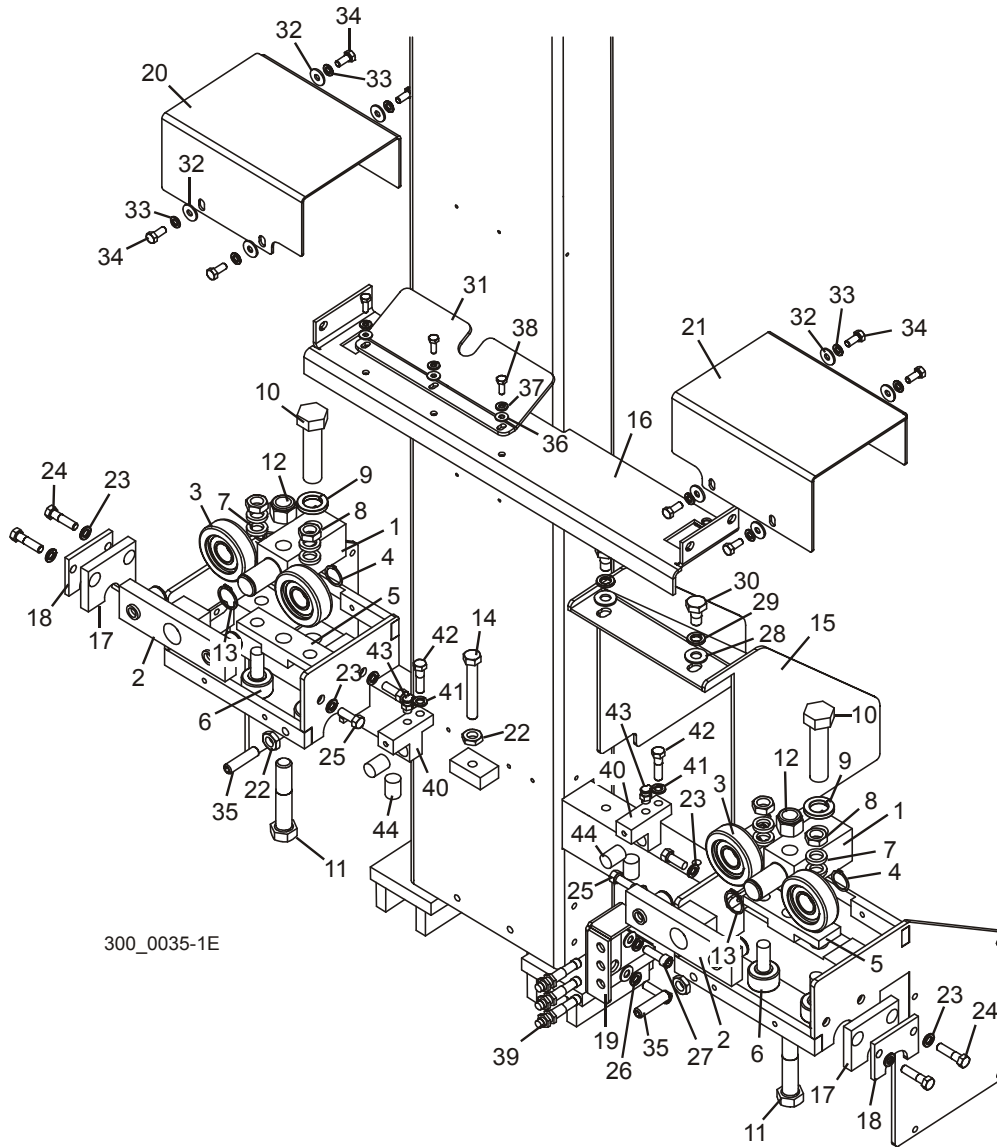

REF	DESCRIPTION (◆ Indicates Parts Available In Assemblies Only)	PART #	QTY.
	BLOCK ASSEMBLY, UPPER TRACK ROLLER	042506	2
1	Block, Upper Track Roller Mount	042505	1
2	Block Assembly, Upper Roller	042507	1
3	Bearing, MG305DDA	023857	2
4	Ring, 1" Outside Retaining	F04254-15	2
5	Block, Track Roller Mount	042500	1

6	Bearing, 1 1/2" Track Roller	012797	2	
7	Spacer, 41/64" x 1" x 3/16"	S12480	4	
8	Nut, 5/8-18 Hex Jam	F05010-11	2	
9	Washer, 7/8" Split Lock	F05011-46	1	
10	Bolt, 7/8-14 x 3 1/2" Hex Head Grade 5	F05014-1	1	
11	Bolt, 3/4-10 x 4" Hex Head Grade 5	F05013-3	1	
12	Nut, 3/4-10 Hex Nylon Lock	F05010-103	1	
13	Ring, 1 1/8" External Retaining Ring	F04254-36	1	
14	BOLT, 1/2-13 X 3 1/2" HEX HEAD FULL THREAD	F05008-11	1	
15	RAMP WELDMENT, SAWDUST	042379	1	
16	COVER WELDMENT, UPPER TRACK ROLLER CENTER	042391	1	
17	PAD, PLASTIC WIPER	045175	2	
18	PLATE, WIPER PAD	045176	2	
19	BRACKET, PROXIMITY SENSOR MOUNT	042112	1	
20	COVER, RIGHT UPPER TRACK ROLLER	042394	1	
21	COVER, LEFT UPPER TRACK ROLLER	042368	1	
22	NUT, 1/2-13 HEX JAM	F05010-31	3	
23	WASHER, 3/8" SPLIT LOCK	F05011-4	10	
24	BOLT, 3/8-16 X 1 1/2" HEX HEAD	F05007-3	4	
25	BOLT, 3/8-16 X 1" HEX HEAD	F05007-7	4	
26	WASHER, 3/8" SAE FLAT	F05011-3	2	
27	BOLT, 3/8-16 X 1 1/4" SOCKET HEAD	F05007-150	2	
28	WASHER, 1/2" SAE FLAT	F05011-2	2	
29	WASHER, 1/2" SPLIT LOCK	F05011-9	2	
30	BOLT, 1/2-13 X 1" HEX HEAD	F05008-50	2	
31	PLATE, SAWDUST RAMP	016801	1	
32	WASHER, 5/16" STANDARD FLAT	F05011-16	8	
33	WASHER, 5/16" SPLIT LOCK	F05011-13	8	
34	BOLT, 5/16-18 X 3/4" HEX HEAD	F05006-5	8	
35	SCREW, 1/2-13 X 2" FLAT POINT SOCKET SET	F05008-130	2	
36	WASHER, 1/4" SAE FLAT	F05011-11	3	
37	WASHER, 1/4" SPLIT LOCK	F05011-14	3	
38	BOLT, 1/4-20 X 3/4" HEX HEAD	F05005-129	3	
39	SENSOR, XS2D12PA14OD PROXY	093172	3	
40	BLOCK, UPPER TRACK OILER	045045	2	
41	WASHER, 3/8" SPLIT LOCK	F05011-4	2	
42	BOLT, 3/8-16 X 1 1/2" HEX HEAD	F05007-3	2	
43	FITTING, 1/8" NPT OIL W/COVER	036333	2	
44	PAD, ROUND FELT WIPER	033375	4	

6.2 Lower Track Rollers

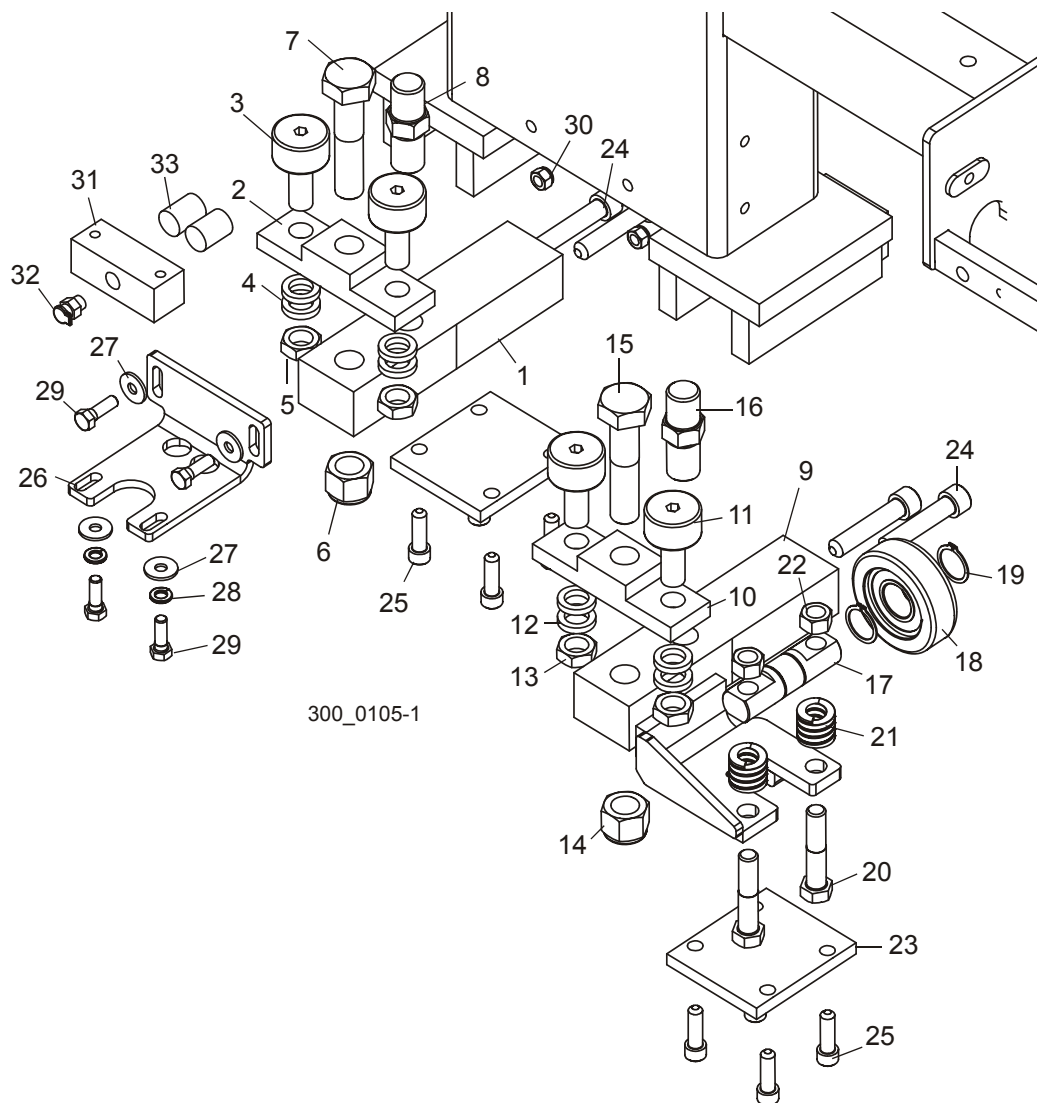

300_0105-1

REF	DESCRIPTION (◆ Indicates Parts Available In Assemblies Only)	PART #	QTY.
	BLOCK ASSEMBLY, LOWER TRACK ROLLER	036345	1
1	Block Weldment, Lower Track Roller Mount	036326	1
2	Block, Track Roller Mount	042500	1
3	Bearing, 1 1/2" Track Roller	012797	2
4	Spacer, 41/64" x 1" x 3/16"	S12480	4
5	Nut, 5/8-18 Hex Jam	F05010-11	2
6	Nut, 3/4-10 Hex Nylon Lock	F05010-103	1
7	Bolt, 3/4-10 x 3 1/2" Hex Head	F05009-54	1
8	Pin, Head Safety Lock (Threaded)	036324	1

	BLOCK ASSEMBLY, LOWER TRACK ROLLER W/BOTTOM ROLLER	036701	1	
9	Block Weldment, Lower Track Roller Mount w/Bottom Roller	036700	1	
10	Block, Track Roller Mount	042500	1	
11	Bearing, 1 1/2" Track Roller	012797	2	
12	Spacer, 41/64" x 1" x 3/16"	S12480	4	
13	Nut, 5/8-18 Hex Jam	F05010-11	2	
14	Nut, 3/4-10 Hex Nylon Lock	F05010-103	1	
15	Bolt, 3/4-10 x 3 1/2" Hex Head	F05009-54	1	
16	Pin, Head Safety Lock (Threaded)	036324	1	
17	Shaft, Bottom Roller Mount	023858	1	
18	Ring, 1" Outside Retaining	F04254-15	2	
19	Bearing, MG305DDA	023857	1	
20	Bolt, 1/2-13 x 2 1/2" Hex Head Grade 5	F05008-74	2	
21	Spring, 1/2" ID x 1" OD x 1" Die	036713	2	
22	Nut, 1/2-13 Hex Lock	F05010-3	2	
23	PLATE, LOWER ROLLER RETAINER	045158	2	
24	BOLT, 1/2-20 X 2 1/2" SOCKET HEAD	F05008-45	4	
25	BOLT, 3/8-16 X 1 1/4" SOCKET HEAD	F05007-150	8	
26	PLATE, LOWER TRACK OILER MOUNT	042415	1	
27	WASHER, 5/16" STANDARD FLAT	F05011-16	4	
28	WASHER, 5/16" SPLIT LOCK	F05011-13	2	
29	BOLT, 5/16-18 X 1" HEX HEAD	F05006-1	4	
30	NUT, 5/16-18 HEX NYLON LOCK	F05010-58	2	
31	BLOCK, LOWER TRACK OILER	036334	1	
32	FITTING, 1/8" NPT OIL W/COVER	036333	1	
33	PAD, ROUND FELT WIPER	033375	2	

6.3 Power Feed Drive

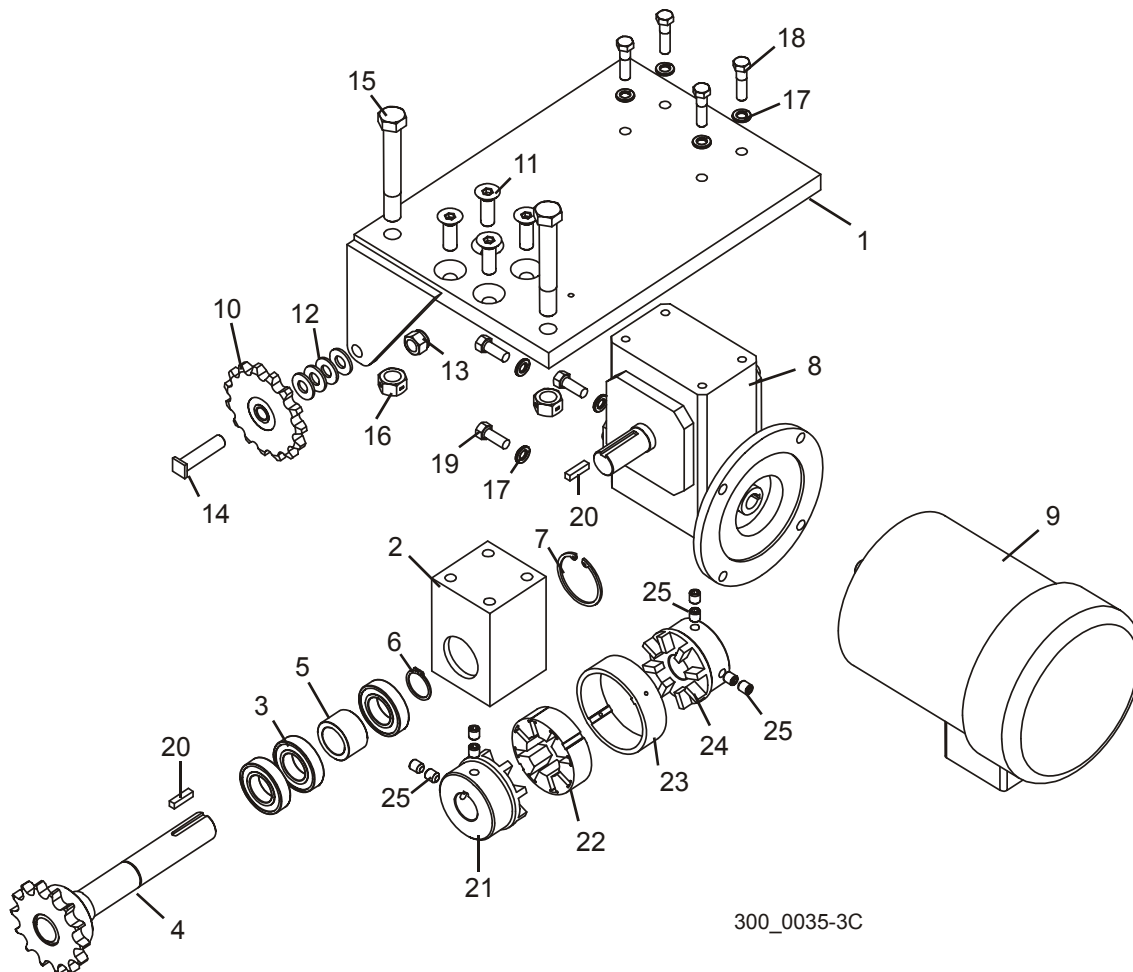

REF	DESCRIPTION (◆ Indicates Parts Available In Assemblies Only)	PART #	QTY.
	DRIVE ASSEMBLY, POWER FEED	042382	1
1	Bracket Weldment, Power Feed Drive Mount	042384	1
	Shaft Assembly, Power Feed Drive	042383	1
2	Block, Power Feed Drive Shaft Bearing	042381	1
3	Bearing, R16 Sealed	042360	3
4	Shaft Weldment, Power Feed Drive	042365	1
5	Spacer, Power Feed Bearing	042387	1
6	Ring, 1 1/8" Outside Retaining	F04254-36	1
7	Ring, 2 1/8" Inside Retaining	F04254-38	1
8	Gearbox, LT300 Power Feed	042356	1
9	Motor, 2HP Power Feed	042390	1
10	Sprocket, 6015 x 1/2" Idler	042367	1
11	Screw, 1/2-13 x 1 1/2" Flat Socket Head	F05008-80	4

12	Washer, 1/2" SAE Flat	F05011-2	4	
13	Nut, 1/2-13 Nylon Lock	F05010-8	1	
14	Shaft, Power Feed Idler Sprocket	016828	1	
15	Bolt, 5/8-11 x 4 1/2" Hex Head Grade 5	F05009-10	2	
16	Nut, 5/8-11 Hex Lock	F05010-4	2	
17	Washer, 3/8" Split Lock	F05011-4	8	
18	Bolt, 3/8-16 x 1 1/2" Hex Head	F05007-3	4	
19	Bolt, 3/8-16 x 1" Hex Head	F05007-7	4	
20	Key, 1/4" x 1"	S21486	2	
	Coupling, Power Feed Shaft	042655	1	
21	Coupling Body, 10R x 1 1/8"	042655-4	1	
22	Coupling Spider, 10R Urethane	042655-2	1	
23	Coupling Ring, 10R Steel	042655-5	1	
24	Coupling Body, 10R x 1"	042655-1	1	
25	Screw, M10 x 1.5 x 12mm Socket Head Set	F05004-189	8	

6.4 Feed Chain & Stops

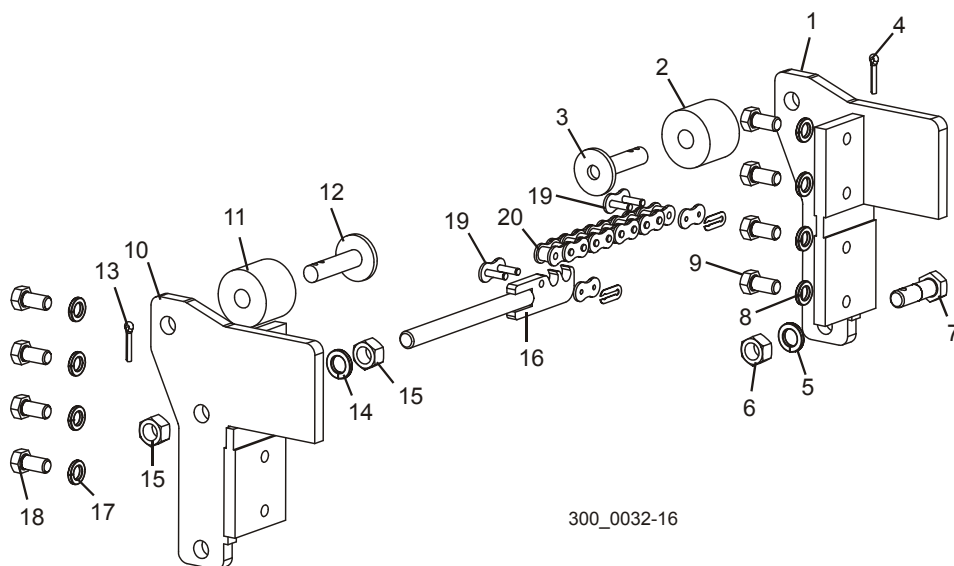

REF	DESCRIPTION (◆ Indicates Parts Available In Assemblies Only)	PART #	QTY.
	STOP ASSEMBLY, FRONT SAW HEAD	035646	1
1	Bracket Weldment, Front Saw Head Stop	042408	1
2	Bushing, 11/16" x 2 1/8" x 1 3/4" Rubber	P12165	1
3	Pin Weldment, Head Stop	W09293	1
4	Pin, 3/16" x 1" Cotter	F05012-21	1
5	Washer, 5/8" Split Lock	F05011-27	1
6	Nut, 5/8-18 Hex	F05010-50	1
7	Bolt, #60 Feed Chain Tensioner	035653	1
8	Washer, 1/2" Split Lock	F05011-9	4
9	Bolt, 1/2-13 x 1 Hex Head Grade 8	F05008-128	4
	STOP ASSEMBLY, REAR HEAD	036199	1
10	Stop Weldment, Right	042411	1
11	Bushing, 11/16" x 2 1/8" x 1 3/4" Rubber	P12165	1
12	Pin Weldment, Head Stop	W09293	1
13	Pin, 3/16" x 1" Cotter	F05012-21	1
14	Washer, 5/8" Split Lock	F05011-27	1
15	Nut, 5/8-18 Hex	F05010-50	2
16	Rod Weldment, #60 Feed Chain Tensioner	035652	1
17	Washer, 1/2" Split Lock	F05011-9	4
18	Bolt, 1/2-13 x 1 Hex Head Grade 8	F05008-128	4
19	Link, #60 Master	042398	2
20	Chain, #60 x 27' Power Feed	036200	1

6.5 Lower Wireway

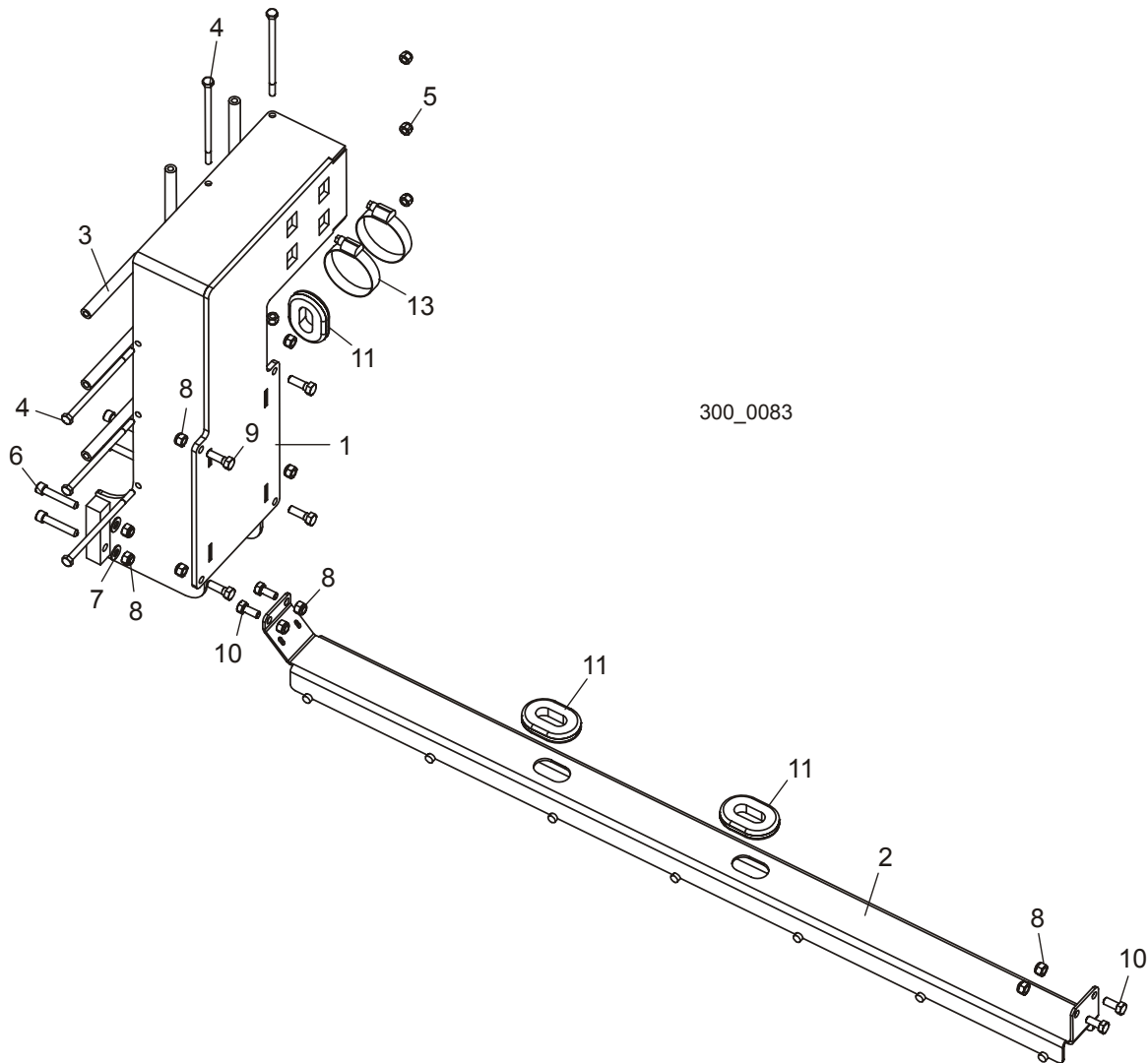

REF	DESCRIPTION (◆ Indicates Parts Available In Assemblies Only)	PART #	QTY.
	CARRIER ASSEMBLY, LOWER MAST CABLE	036342	1
1	Mount Weldment, Cable Carrier	036329	1
2	Cable Carrier, Lower	036341	1
3	Spacer, Wireway	042111	5
4	Bolt, 1/4-20 x 5" Hex Head	F05005-146	5
5	Nut, 1/4-20 Hex Nylon Lock	F05010-69	5
6	Bolt, 5/16-18 x 1 3/4" Socket Head	F05006-65	4
7	Washer, 5/16 SAE Flat	F05011-17	4
8	Nut, 5/16-18 Hex Nylon Lock	F05010-58	12

6 Power Feed

Lower Wireway

9	Bolt, 5/16-18 x 1" Hex Head	F05006-1	4	
10	Bolt, 5/16-18 x 3/4" Hex Head	F05006-5	4	
11	Grommet, 1" x 1 3/4" Oval Rubber	085613	3	
12	Clamp, 2-1/2" Worm	P09895	2	

SECTION 7 BED FRAME ASSEMBLY

7.1 Bed Rails

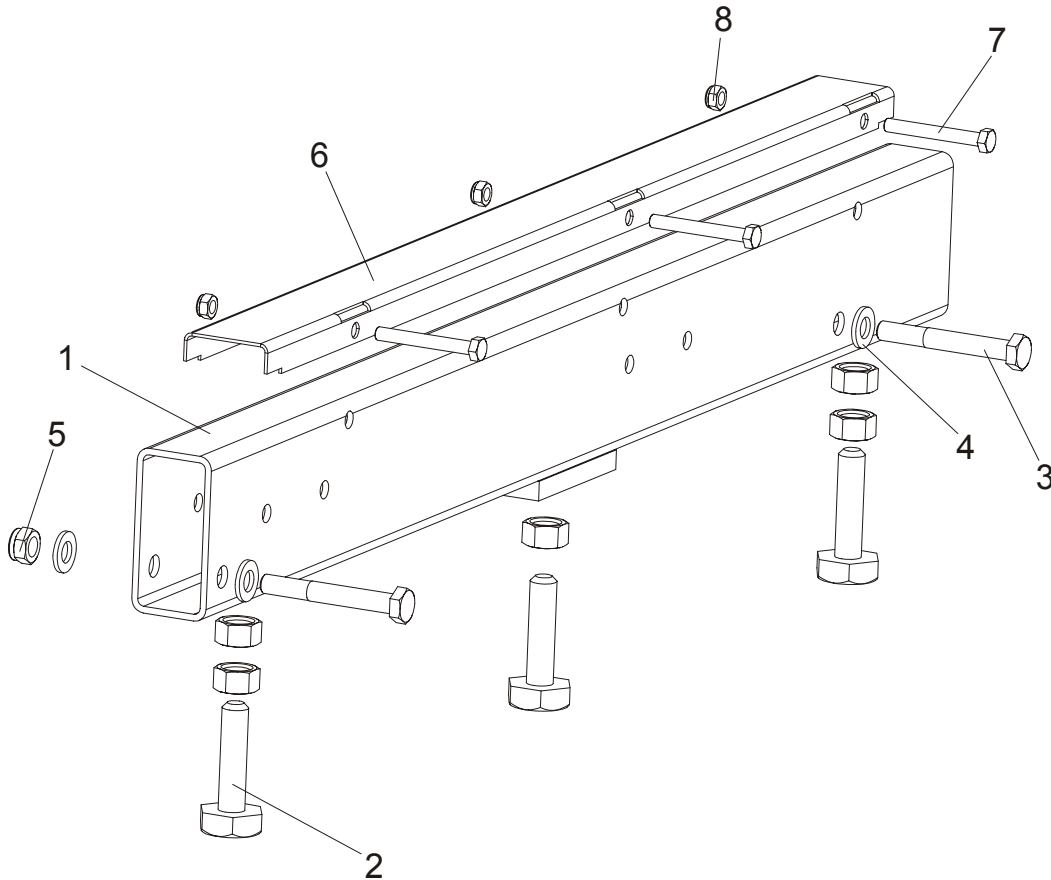

REF	DESCRIPTION (◆ Indicates Parts Available In Assemblies Only)	PART #	QTY.
1	TUBE, BED RAIL	096994	1
2	ADJUSTMENT BOLT (M16) & TWO NUTS	093710	3
3	BOLT, M12x90-8.8 HEX HEAD ZINC	F81004-2	2
4	WASHER, 13 FLAT ZINC	F81056-1	4
5	NUT, M12-8 HEX NYLON ZINC LOCK	F81034-2	2
6	COVER, STAINLESS STEEL BED RAIL	S09944	1
7	BOLT, M8x65-5.8 HEX HEAD ZINC	F81002-3	3
8	NUT, M8-8-B HEX NYLON ZINC LOCK	F81032-2	3

7 BED FRAME ASSEMBLY

Wireway Assembly

7.2 Wireway Assembly

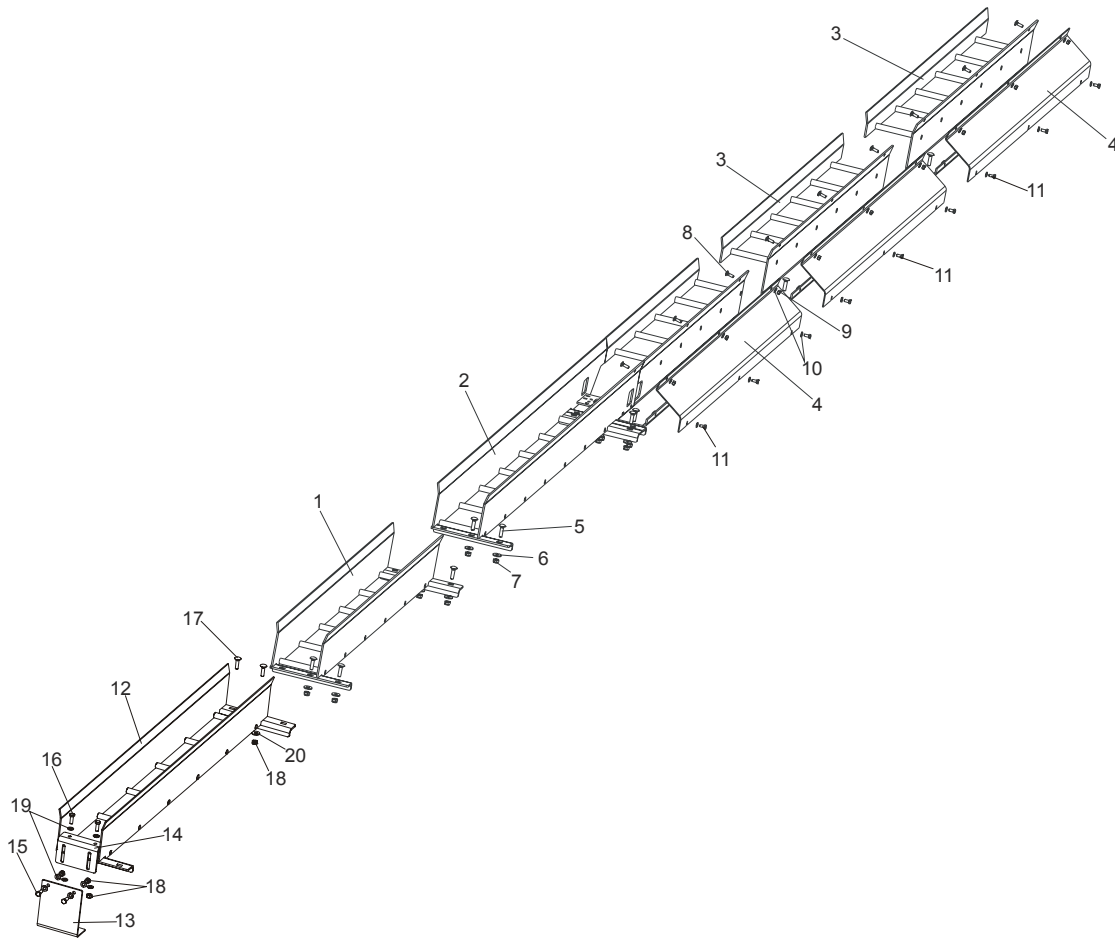

REF	DESCRIPTION (◆ Indicates Parts Available In Assemblies Only)	PART #	QTY.	
	WIREWAY ASSEMBLY, LT300	093570		
1	Wireway Weldment, LT300 Painted (1)	093555-1	1	
2	Wireway Weldment, LT300 Painted (3)	093569-1	1	
3	Wireway Weldment, LT300 Painted (2)	093568-1	2	
4	Cover, LT300/300 Wireway (1)	093550	3	
5	Bolt, Z M10x40 -8.8 Carriage Head Zinc	F81003-40	15	
6	Washer, 10.5 Special Flat Zinc	F81055-6	15	
7	Nut, M10-8-B Hex Nylon Zinc Lock	F81033-1	15	
8	Bolt, M8x20-8.8 Carriage Head Zinc	F81002-11	9	
9	Nut, M8-8-B Hex Zinc	F81032-1	9	
10	Washer, 8.4 Flat Zinc	F81054-1	18	
11	Bolt, M8x16 -8.8-B Hex Head Full Thread Zinc	F81002-20	9	

	WIREWAY ASSEMBLY, REAR COMPLETE			
12	Wireway Weldment, LT300 Painted (1)	093555-1	1	
13	Bracket, Wireway Weldment	099791-1	1	
14	Bracket, LT70/300 Wireway Weldment	099793-1	1	
15	Bolt, M10-1.5x25mm HH Gr8.8	F81003-11	2	
16	Bolt, M10X30-5.8 Hex Head Full Threat	F81003-2	2	
17	Bolt, Z M10x40 -8.8 Carriage Head Zinc	F81003-40	2	
18	Nut, M10-8-B Hex Nylon Zinc Lock	F81033-1	6	
19	Washer, 10.5 Flat Zinc	F81055-1	8	
20	Washer, 10.5 Special Flat Zinc	F81055-6	2	

7 BED FRAME ASSEMBLY

Cable Carrier

7.3 Cable Carrier

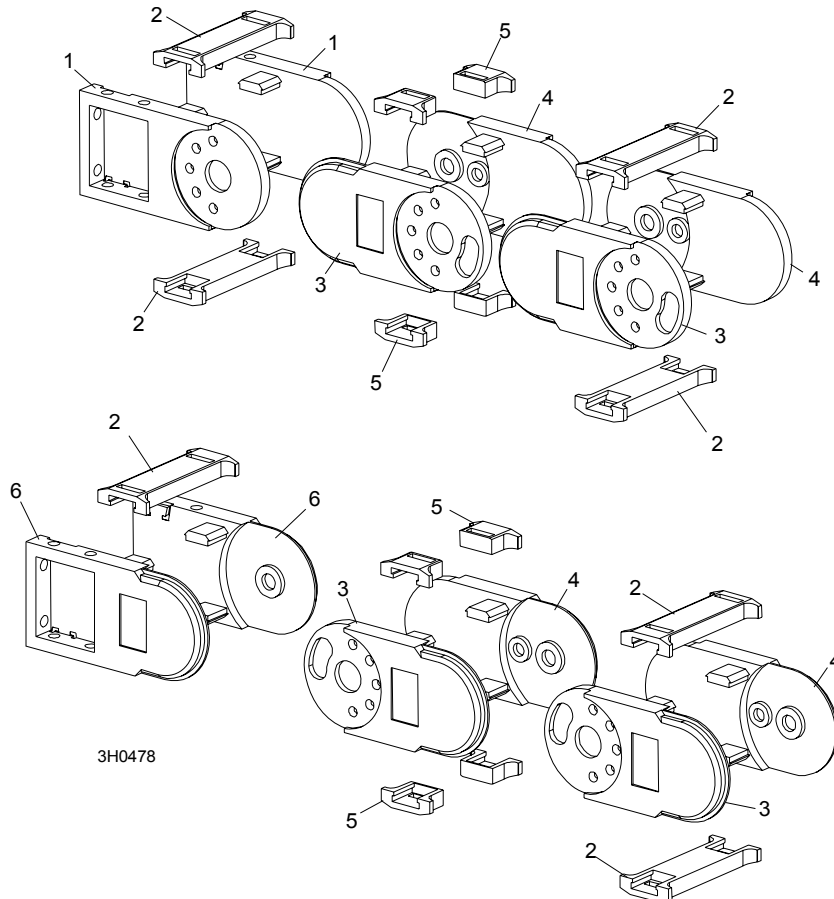

REF	DESCRIPTION (◆ Indicates Parts Available In Assemblies Only)	PART #	QTY.
	CABLE CARRIER, LT70REMOTE/LT300	094389	1
1	Link, Nylon Chain Top Mount	023612-3	2
2	Brace, Nylon Chain Long Cross	023612-4	68
3	Link, Nylon Chain Right Side #4040AA	036219	66
4	Link, Nylon Chain Left Side #4040AA	036220	66
5	Brace, Nylon Chain Short Cross	023612-5	136
6	Link, Nylon Chain Bottom Mount	023612-9	2

7.4 Stationary Legs

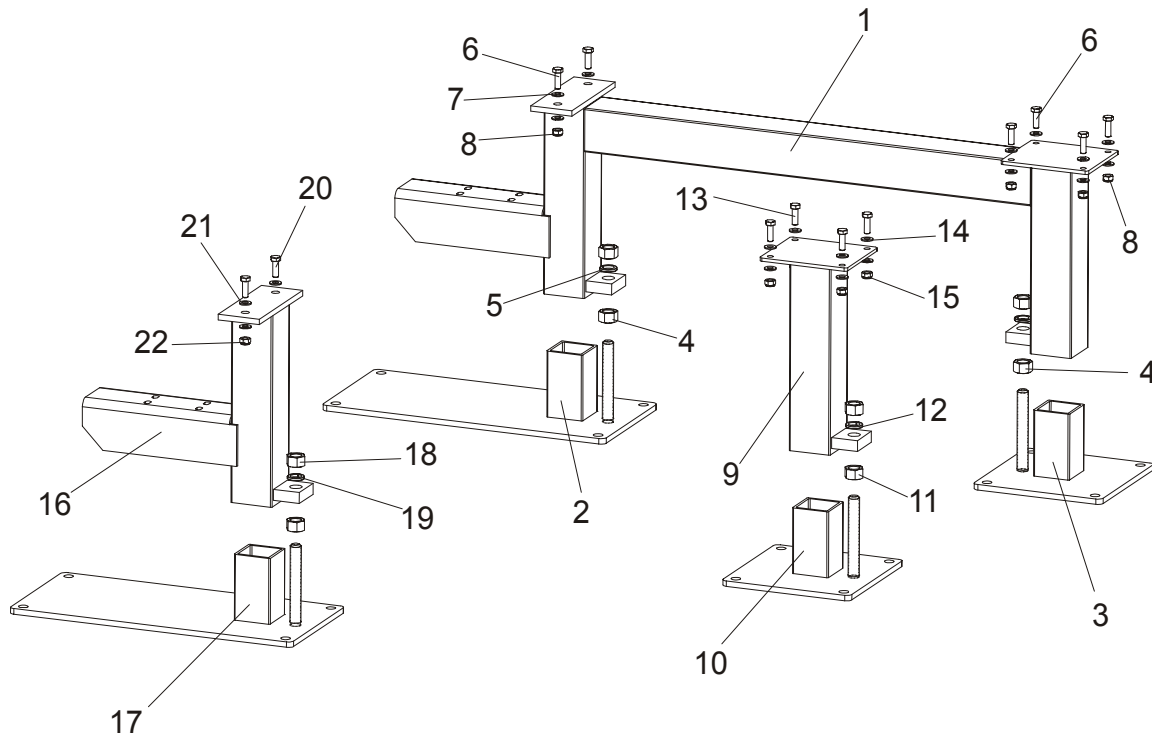

REF	DESCRIPTION (◆ Indicates Parts Available In Assemblies Only)	PART #	QTY.
	STATIONARY LEG KIT, LT300	092975-1	
	Leg Assembly, LT300 Stationary (3)	089288	4
1	Leg Weldment, Stationary Painted - Upper Part (2)	089277-1	1
2	Plate Weldment, LT300 Leg Foot (2)	093564-1	1
3	Plate Weldment, Leg Foot	089283-1	1
4	Nut, M20-8 Hex Zinc	F81037-1	4
5	Washer, 20.5 Split Lock Zinc	F81059-1	2
6	Bolt, M10x30-5.8 Hex Head Full Thread Zinc	F81003-2	6
7	Washer, 10.5 Flat Zinc	F81055-1	12
8	Nut, M10-8-B Hex Nylon Zinc Lock	F81033-1	6
	Stationary Leg, LT300	093326	2
9	Leg Weldment, LT300 Stationary -Upper Part (2)	091790-1	1
10	Plate Weldment, Leg Foot (3)	089283-1	1
11	Nut, M20-8 Hex Zinc	F81037-1	2
12	Washer, 20.5 Split Lock Zinc	F81059-1	1
13	Bolt, M10x30-5.8 Hex Head Full Thread Zinc	F81003-2	4
14	Washer, 10.5 Flat Zinc	F81055-1	8
15	Nut, M10-8-B Hex Nylon Zinc Lock	F81033-1	4
	Stationary Leg, LT300 (2)	093325	2

7 **BED FRAME ASSEMBLY**

Stationary Legs

16	Leg Weldment, LT300 Stationary - Upper Part (5)	089350-1	1	
17	Plate Weldment, LT300 Leg Foot (2)	093564-1	1	
18	Nut, M20-8 Hex Zinc	F81037-1	2	
19	Washer, 20.5 Split Lock Zinc	F81059-1	1	
20	Bolt, M10x30-5.8 Hex Head Full Thread Zinc	F81003-2	2	
21	Washer, 10.5 Flat Zinc	F81055-1	4	
22	Nut, M10-8-B Hex Nylon Zinc Lock	F81033-1	2	

7.5 Board Return Roller Assembly

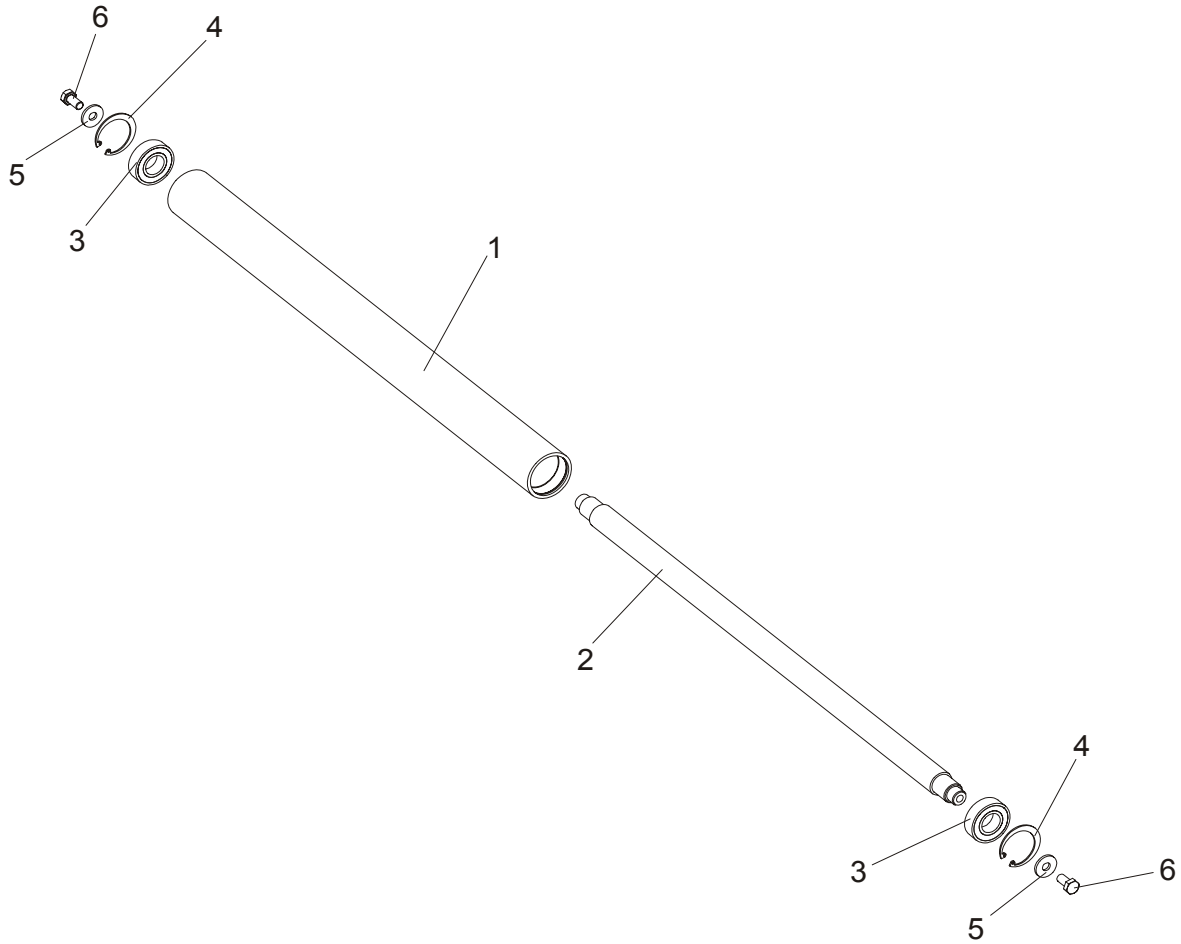

REF	DESCRIPTION (◆ Indicates Parts Available In Assemblies Only)	PART#	QTY.
	ROLLER ASSEMBLY, LT300 PAINTED	093291-1	1
1	Tube, LT300 Roller	091781	1
2	Shaft, LT300 Roller	091793	1
3	Bearing, 6205 2RS	091804	2
4	Ring, W50 Inside Retaining	091805	2
5	Washer, 10.5 Special Flat Zinc	F81055-6	2
6	Bolt, M10x20-5.8 Hex Head Full Thread Zinc	F81003-1	2

SECTION 8 HYDRAULIC SYSTEM

8.1 Hydraulic Hoses, LT300

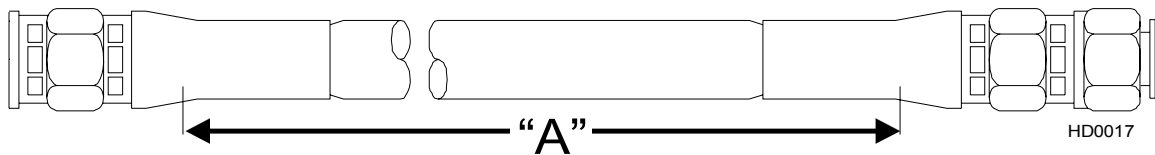

Symbol	Color Code	Qty.	Length "A"	Description	Wood-Mizer Part No.
H1	None	1	1.1m	3/8" Front Side Support From Tee Fitting, Base	094593
H2	None	1	0.95m	3/8" Rear Side Support From Tee Fitting, Base	094594
H3	None	1	0.92m	3/8" Front Side Support From Oil Flow Divider, Top	094595
H4	None	1	0.72m	3/8" Rear Side Support From Oil Flow Divider, Top	094596
H5	None	1	0.65m	3/8" Turner To Oil Flow Divider	094597
H6	None	1	0.62m	3/8" Turner To Tee Fitting	094598
H7	White/Orange	2	4.5m	1/4" Middle Pull-Down Clamp (In-Out)	094752
H8		2	4.7m	1/4" 1st Toe Board	094753
H9		2	5.1m	1/4" 2nd Pull-Down Clamp (Up/Down)	094754
H10	Yellow	1	7.4m	1/4" 2-Plane Clamp, (Up/Down) Base	094755
H11	Black (base)/ Purple (top)	2	7.6m	1/4" 2nd Toe Board	094756
H12	Orange/White	2	7.9m	1/4" 3rd Pull-Down Clamp (In-Out)	094757
H13	Red/Blue	2	8.3m	1/4" 3rd Pull-Down Clamp (Up-Down)	094758
H14		2	6.3m	1/2" Hydro-Motor	094794
H15		2	6.5m	3/8" Turner (Up-Down)	094760
H16	Orange/White	2	6.4m	3/8" 2-Plane Clamp (In/Out)	094761
H17	Blue/Red	2	8m	3/8" Log Infeed Deck	094762
H18	White/Orange	2	2.5m	1/4" 1st Pull-Down Clamp (In/Out)	095061

TABELA 8-0

HYDRAULIC SYSTEM

Hydraulic Hoses, LT300

8

H19	Red/ Blue	2	3.2m	1/4" 1st Pull-Down Clamp (Up/Down)	095062
------------	--------------	---	------	------------------------------------	--------

TABELA 8-0

8 HYDRAULIC SYSTEM

Hydraulic Valve

8.2 Hydraulic Valve

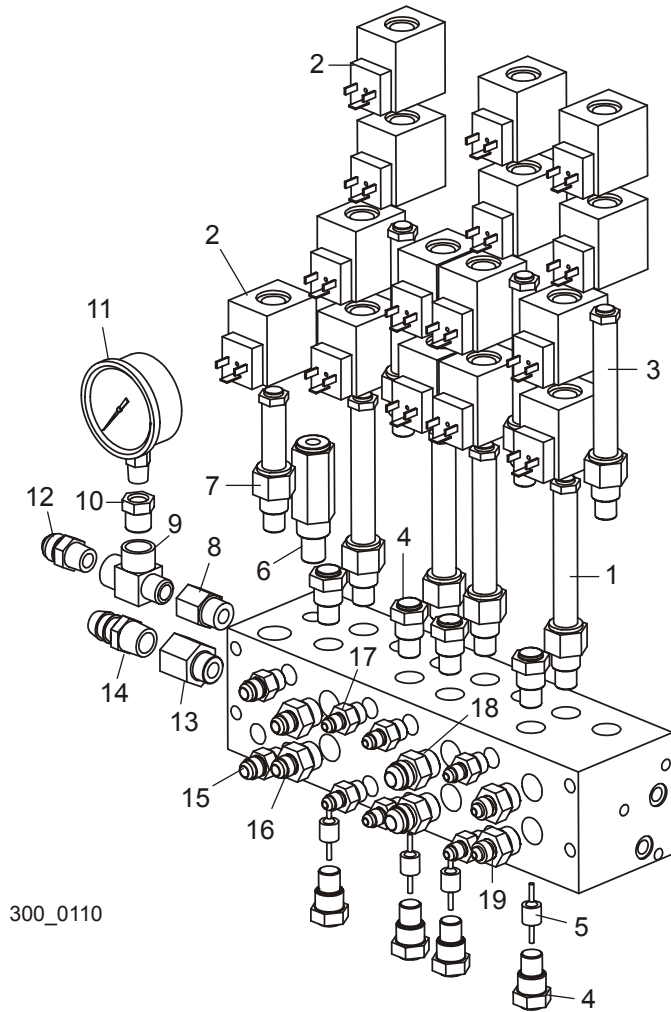

300_0110

REF	DESCRIPTION (◆ Indicates Parts Available In Assemblies Only)	PART #	QTY.
	VALVE ASSEMBLY, LT300 HYDRAULIC	036758	1
	Valve, 7-Spool Expandable Hydraulic	036731	1
1	Valve, Hi-Flow Floating Center Sterling #GS04-53	045820	4
2	Coil, 24V Sterling #CAP-024D	051558	15
3	Valve, 4-Way Sterling #GS04-51	051556	3
4	Valve, Check Sterling #D02B2-2.1N	051559	8
5	Piston, Pilot Sterling #PP02DP	051660	4
6	Valve, Relief Sterling #208-1-B-0-A-C-200	051554	1
7	Valve, 2-Way NO Sterling #GS04-26	051555	1
8	Fitting, #8 SAE x 3/8" NPT Female Adapter	P12706	1
9	Fitting, 3/8" NPT Male Run Tee	016822	1
10	Fitting, 3/8" NPT-1/4 NPT Reducer	015490	1

11	Gauge, 5000 PSI Hydraulic	P10052	1	
12	Fitting, 3/8" NPT x #8 JIC	036822	1	
13	Fitting, #8SAE x 1/2" NPT Female Adapter	035620	1	
14	Fitting, 1/2" NPT x 3/4" Hose Barb	035621	1	
15	Fitting, 3/8" O-Ring x 3/8" JIC	014687	2	
16	Fitting, #8 SAE x #6 JIC	P12703	2	
17	Fitting, 1/4" JIC x 3/8" O-Ring	P26284	6	
18	Fitting, #8 SAE x #8 JIC	028076	2	
19	Fitting, #8 SAE x 1/4" JIC	036759	2	

8 HYDRAULIC SYSTEM

Hydraulic Log Turner

8.3 Hydraulic Log Turner

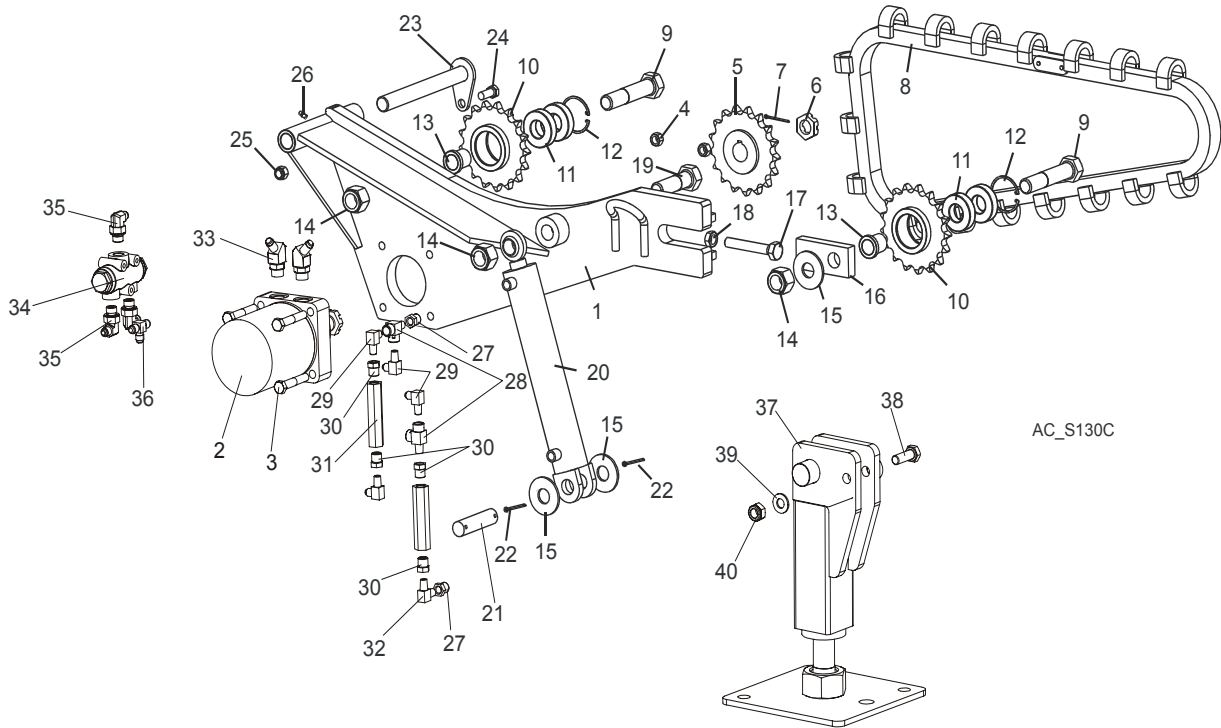

REF	DESCRIPTION (◆ Indicates Parts Available In Assemblies Only)	PART #	QTY.
	TURNER ASSEMBLY, HYDRAULIC LOG	034537	1
1	Arm Weldment, Hydraulic Log Turner	016873	1
2	Motor, MB29-02-08-AABP Hydraulic	018741	1
3	Bolt, 1/2-13 x 3" Hex Head Grade 5	F05008-23	4
4	Nut, 1/2-13 Hex Lock	F05010-3	4
5	Sprocket Weldment, Log Turner Drive	042192	1
6	Nut, Hydraulic Motor Castle	018741-2	1
7	Pin, 1/8" x 1 3/4" Cotter	F05012-43	1
8	Chain Weldment, Log Turner	042196	1
	Cog, Log Turner	042194	17
	Chain, #2080 Log Turner	042195	1
	Link, #2080H Master	016796	1
9	Bolt, 1-8 x 5" Hex Head Grade 8	F05004-132	2
	Sprocket Assembly, Idler	042193	2
10	Sprocket Weldment, Idler	042191	1
11	Bearing, 6206 25 Idler	P11035	2
12	Ring, 62mm #472 DIN Inside Retaining	F04254-12	1
13	Spacer, Idler Sprocket	042187	2
14	Nut, 1-8 Hex Lock	F05010-109	3

15	Washer, 1" SAE Flat	F05011-28	3	
16	Plate, Log Turner Chain Tensioner	042188	1	
17	Bolt, 5/8-11 x 4" Hex Head Full Thread Grade 5	F05009-31	1	
18	Nut, 5/8-11 Hex Jam	F05010-82	1	
19	Bolt, 1-8 x 3 1/2" Hex Head Grade 5	F05009-50	1	
20	Cylinder, 2" x 10" Welded Rod End Hydraulic	034267	1	
21	Pin, 1" x 3.88" Hydraulic Cylinder	S09251	1	
22	Pin, 3/16" x 1 1/2" Cotter	F05012-23	2	
23	Pin Weldment, Log Turner Mount	042331	1	
24	Bolt, 1/2-13 x 1 1/4" Hex Head Grade 5	F05008-37	1	
25	Nut, 1/2-13 Hex Nylon Lock	F05010-8	1	
26	Fitting, 1/4-28 Grease	P05060	1	
	Hydraulic Cylinder Connection Parts	094383	1	
27	Fitting, 3/8NPT - 1/4NPT Reducer	015490	2	
28	Fitting, C3759X4 Male Run Tee	P09141	2	
29	Fitting, 3/8JIC-1/4NPT 90L	015491	4	
30	Fitting, 3/8NPT - 1/4NPT Reducer	015490	6	
31	Valve, Log Side Support Sequence	015484	2	
32	Fitting, 90° #C3529X4 Male Pipe Elbow	P09140	1	
33	Fitting, #10SAE - 1/2JIC 45 Elbow	016807	2	
34	Divider, MTD A 08-016M 1/2 / 1/2 Oil Flow	088191	1	
35	Fitting, 90 18x1.5 9/16-18 JIC Elbow	089992	2	
36	Fitting, 3/8JIC Tee	015487	1	
37	LEG, LT300 TURNER COMPLETE	099975	1	
38	Bolt, M10X30-5.8 Hex Head Full Threat	F81003-2	1	
39	Washer, 10.5 Flat Zinc	F81055-1	1	
40	Nut, M10-8-B Nylon Hex Zinc Lock	F81033-1	1	

8.4 Hydraulic Log Side Supports

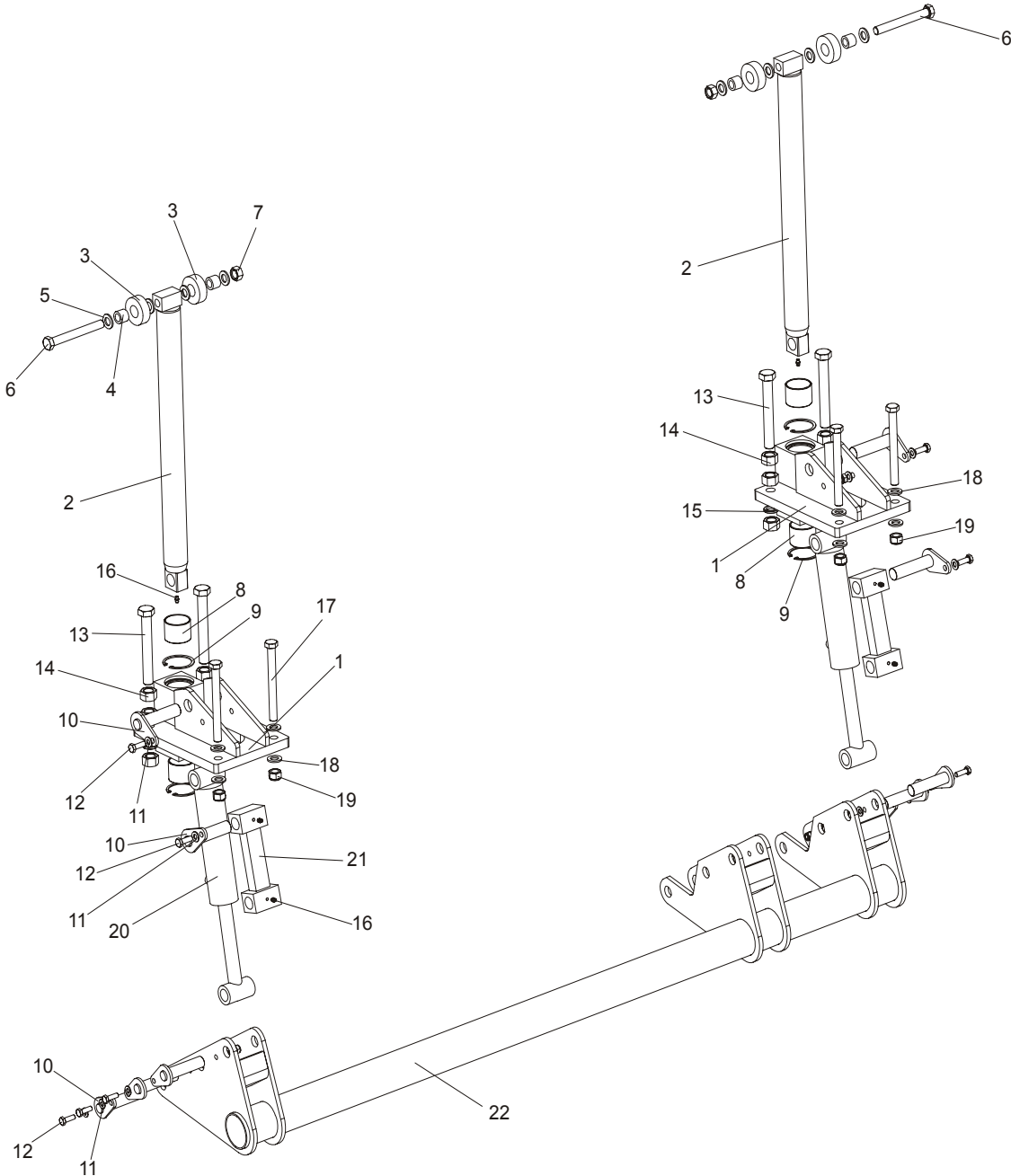

REF	DESCRIPTION (◆ Indicates Parts Available In Assemblies Only)	PART #	QTY.
	SUPPORT 2, LT300 VERTICAL LOG SIDE	097519	1
1	Mount Weldment, LT300 Vertical Side Support Upper	094003-1	1
2	Rod Weldment, LT300 Vertical Side Support Complete	094011-1	1
3	Roller, LT70/300 Vertical Side Support Zinc-Plated	094013-1	2

4	Bushing, LT70/300 Verical Side Support Bronze	094012	2	
5	Washer, 17 Flat Zinc	F81058-1	4	
6	Bolt, M16x140-8.8 Hex Head Zinc	F81006-4	1	
7	Nut, M16-5.8 Hex Zinc	F81036-1	1	
8	Bushing, 5040BS Non-Greasable	088660	1	
9	Ring, 62W Inside Retaining	F81090-1	2	
10	Pin Weldment, Vertical Side Support Zinc-Plated	091197-1	5	
11	Washer, 10.5 Flat Zinc	F81055-1	5	
12	Bolt, M10x30-5.8 Hex Head Full Thread Zinc	F81003-2	5	
13	Bolt, ISO 4017 M20x150 8.8 Zinc-Plated	F81007-3	2	
14	Nut, M20-8 Hex Zinc	F81037-1	6	
15	Washer, 20.5 Split Lock Zinc	F81059-1	2	
16	Fitting, M6 Grease	086280	2	
17	Bolt, M16x160 -8.8 Hex Head Zinc	F81006-20	2	
18	Washer, 17 Flat Zinc	F81058-1	4	
19	Nut, M16-8 Hex Nylon Zinc Lock	F81036-2	2	
20	Cylinder, 28/150 1/4 NPT Port Hydraulic	094002	1	
21	Link Weldment, LT300 Vertical Side Support	094016-1	1	
22	MOUNT WELDMENT, LT300 VERTICAL SIDE SUPPORT	097387-1	1	
	SUPPORT, LT300 VERTICAL LOG SIDE	094010		
1	Mount Weldment, LT300 Vertical Side Support Upper	094003-1	1	
2	Rod Weldment, LT300 Vertical Side Support Complete	094011-1	1	
3	Roller, LT70/300 Vertical Side Support Zinc-Plated	094013-1	2	
4	Bushing, LT70/300 Verical Side Support Bronze	094012	2	
5	Washer, 17 Flat Zinc	F81058-1	4	
6	Bolt, M16x140-8.8 Hex Head Zinc	F81006-4	1	
7	Nut, M16-5.8 Hex Zinc	F81036-1	1	
8	Bushing, 5040BS Non-Greasable	088660	1	
9	Ring, 62W Inside Retaining	F81090-1	2	
10	Pin Weldment, Vertical Side Support Zinc-Plated	091197-1	5	
11	Washer, 10.5 Flat Zinc	F81055-1	5	
12	Bolt, M10x30-5.8 Hex Head Full Thread Zinc	F81003-2	5	
13	Bolt, ISO 4017 M20x150 8.8 Zinc-Plated	F81007-3	2	
14	Nut, M20-8 Hex Zinc	F81037-1	6	
15	Washer, 20.5 Split Lock Zinc	F81059-1	2	
16	Fitting, M6 Grease	086280	2	
17	Bolt, M16x160 -8.8 Hex Head Zinc	F81006-20	2	
18	Washer, 17 Flat Zinc	F81058-1	4	
19	Nut, M16-8 Hex Nylon Zinc Lock	F81036-2	2	
20	Cylinder, 28/150 1/4 NPT Port Hydraulic	094002	1	
21	Link Weldment, LT300 Vertical Side Support	094016-1	1	
22	MOUNT WELDMENT, LT300 VERTICAL SIDE SUPPORT	097289-1	1	

8.5 Hydraulic Log Clamp

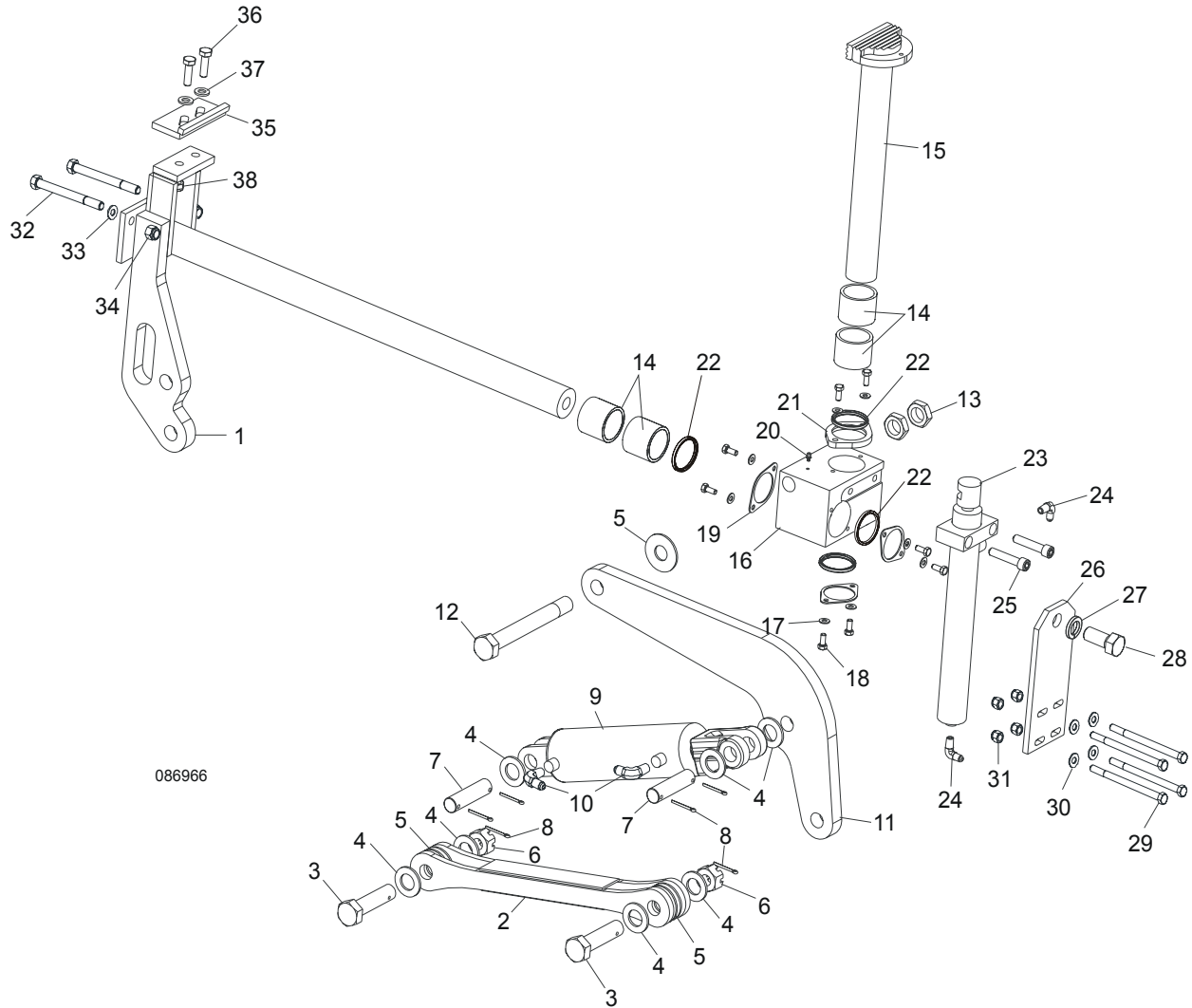

086966

REF	DESCRIPTION (◆ Indicates Parts Available In Assemblies Only)	PART #	QTY.
	LOG CLAMP ASSEMBLY, TWO-PLANE	088658	1
1	Rod Weldment, Log Clamp Slide Painted	086967-1	1
2	Arm Weldment, Hydraulic Clamp Link Painted	086963-1	1
3	Pin, B 24x95/85 Clevis Zinc	F81049-2	1
4	Washer, 25 Flat Zinc	F81061-3	8
5	Washer, 25X63 Zinc-Plated	088585-1	5
6	Nut, M20-8-3 Hex Slotted Castle Zinc	F81037-3	2
7	Pin, Hydraulic Cylinder Zinc-Plated	086979-1	2

8	Pin, 6.3x45 Cotter Zinc	F81045-2	6	
9	Cylinder, CJ-S96-16-70/32/178 Hydraulic	088589	1	
10	Fitting, 90° Male Elbow	P09142	2	
11	Arm, Hydraulic Log Clamp Link Painted	086974-1	1	
12	Bolt, M24x217/39-8.8-B Hex Head Zinc	088586-1	1	
13	Nut, M24 -04-B Hex Thin Zinc	F81039-3	2	
14	Bushing, 5040BS Self-Lubricating	088660	4	
15	Rod Weldment, Log Clamp Vertical Painted	088582-1	1	
16	Block, Log Clamp Painted Steel	088591-1	1	
17	Washer, 8.4 Flat Zinc	F81054-1	8	
18	Bolt, M8x20-8.8-B Hex Head Full Thread Zinc	F81002-4	8	
19	Flange, Clamp Rod Wiper Painted	088887-1	3	
20	Fitting, 3/16" Straight Grease	P04107	1	
21	Flange, Clamp Rod Wiper Painted	088887-1	4	
22	Wiper, ZZ 50x60x7 INCO Log Clamp Rod	088587	4	
23	Cylinder, CJ-S169-16-40/22/254 Hydraulic	088590	1	
24	Fitting, 90° Male Elbow	P09142	2	
25	Screw, M12x55-8.8-B Hex Socket Head Cap Zinc	F81004-23	2	
26	Plate, Log Clamp Mount Painted	086975-1	1	
27	Washer, Z 22.5 Split Lock Zinc	F81059-4	1	
28	Bolt, M22x1.5x40-8.8-B Hex Head Full Thread Zinc	F81009-1	1	
29	Bolt, M10 x 125-8.8 Hex Head Zinc	F81003-18	4	
30	Washer, 10.5 Flat Zinc	F81055-1	4	
31	Nut, M10-8-B Hex Nylon Zinc Lock	F81033-1	4	
32	Bolt, M12 x 130-8.8 Carriage	F81004-26	2	
33	Washer, 13 Flat Zinc	F81056-1	2	
34	Nut, M12-8-B Hex Zinc	F81034-1	2	
	STOP ASSEMBLY, LOG CLAMP	K09485	1	
35	Stop Weldment, Hydraulic Log Clamp Painted	086980-1	1	
36	Bolt, M12 x 40 8.8 Hex Head Full Thread Zinc	F81004-4	2	
37	Washer, 13 Flat Zinc	F81056-1	2	
38	Nut, M12-8 Hex Nylon Zinc Lock	F81034-2	2	

8.6 Hydraulic Log Clamp, Standard

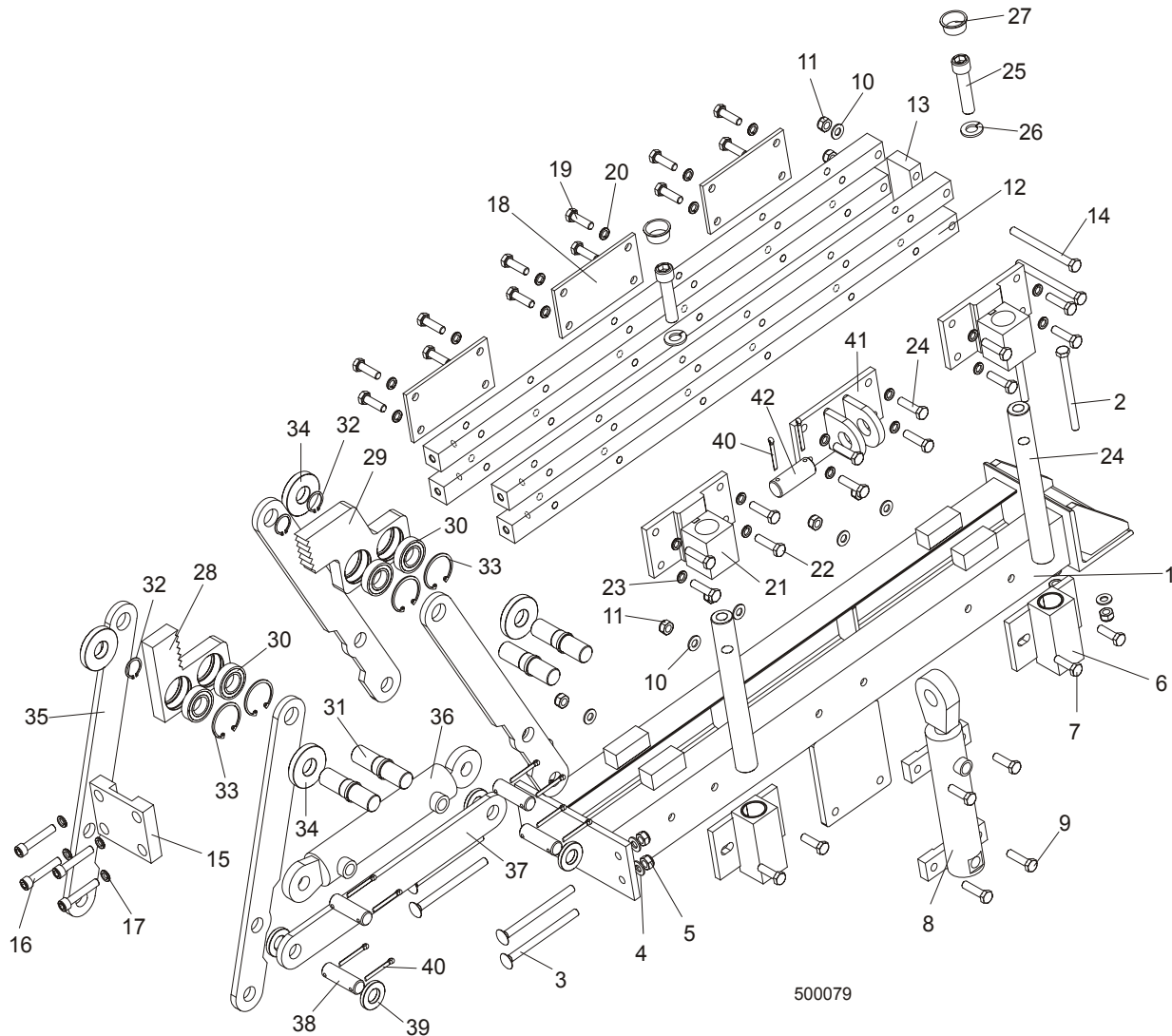

500079

REF	DESCRIPTION (◆ Indicates Parts Available In Assemblies Only)	PART #	QTY.
	CLAMP ASSEMBLY, HYDRAULIC	089545	2
1	Mount Weldment, Hydraulic Log Clamp	088654-1	1
2	Bolt, M10x125-8.8 Zinc Hex Head	F81003-18	2
3	Bolt, M10x130-8.8 Zinc Mushroom Head Square Neck	F81003-36	4
4	Washer, 10.5 Flat Zinc	F81055-1	6
5	Nut, M10-8-B Hex Nylon Zinc Lock	F81033-1	6
6	Block, Guide Pin	089835-1	2
7	Bolt, M10x35-8.8 Zinc Hex Head Full Thread	F81003-17	4
8	Cylinder,CJ7F-16-40/22 + UE2-40W Hydraulic	088662	1
9	Bolt, M10x40-8.8 Zinc Hex Head	F81003-16	4

10	Washer, M10 Flat Zinc	F81055-1	6	
11	Nut, M10-8-b Hex Nylon Zinc Lock	F81033-1	10	
12	Bar, Clamp Up/Down	089537-1	4	
13	Plate, Connecting	088645-1	1	
14	Bolt, M10x140-8.8 Zinc Hex Head	F81003-5	2	
15	Plate, Connecting	089533-1	1	
16	Bolt, M10x55-8.8 Zinc Hex Socket Head Cap	F81003-55	4	
17	Washer,10.2 Split Lock Zinc	F81055-2	4	
18	Plate, Log Clamp Rear	089538-1	3	
19	Bolt, M10x35-8.8 Zinc Hex Head Full Thread	F81003-17	12	
20	Washer,10.2 Split Lock Zinc	F81055-2	12	
21	Bracket, Guide Pin Mount	089536-1	2	
22	Bolt, M10x40-8.8 Zinc Hex Head Full Thread	F81003-16	8	
23	Washer, 10.2 Split Lock Zinc	F81055-2	8	
24	Pin, Clamp Up/Down Guide	088631	2	
25	Screw, M16x55-8.8 Zinc Hex Socket Head Cap	F81006-18	2	
26	Washer, 16.3 Split Lock Zinc	F81058-2	2	
27	Plug, M33 Thread	089839	2	
	Jaw, Log Clamp Left - Complete	094700	1	
28	Jaw, Log Clamp Left	093464-1	1	
30	Bearing, 6005 2RS CX	089652	4	
31	Shaft, Clamp Jaw Guide	088620-1	4	
32	Ring, Z24 Spring Retaining	089654	4	
33	Ring, W47 Spring Retaining	089653	4	
	Jaw, Log Clamp Right - Complete	094701	1	
29	Jaw, Log Clamp Right	093465-1	1	
30	Bearing, 6005 2RS CX	089652	4	
31	Shaft, Clamp Jaw Guide	088620-1	4	
32	Ring, Z24 Spring Retaining	089654	4	
33	Ring, W47 Spring Retaining	089653	4	
34	Washer, Clamp Jaw Spacer	089542	4	
35	Bar, Clamp In/Out Side	088622-1	4	
36	Cylinder, SJ2F-40/22/145 Hydraulic	088661	1	
37	Bar, Clamp In/Out Lower	088623-1	1	
38	Pin, 20X75	088657-1	4	
39	Spacer, Lower	089541	4	
40	Pin, S-Zn 5x40 Cotter	F81043-31	10	
41	Bracket, Vertical Cylinder Mount Upper	089540-1	1	
42	Pin, 25X75	088659-1	1	

8.7 Hydraulic Log Clamp, Optional

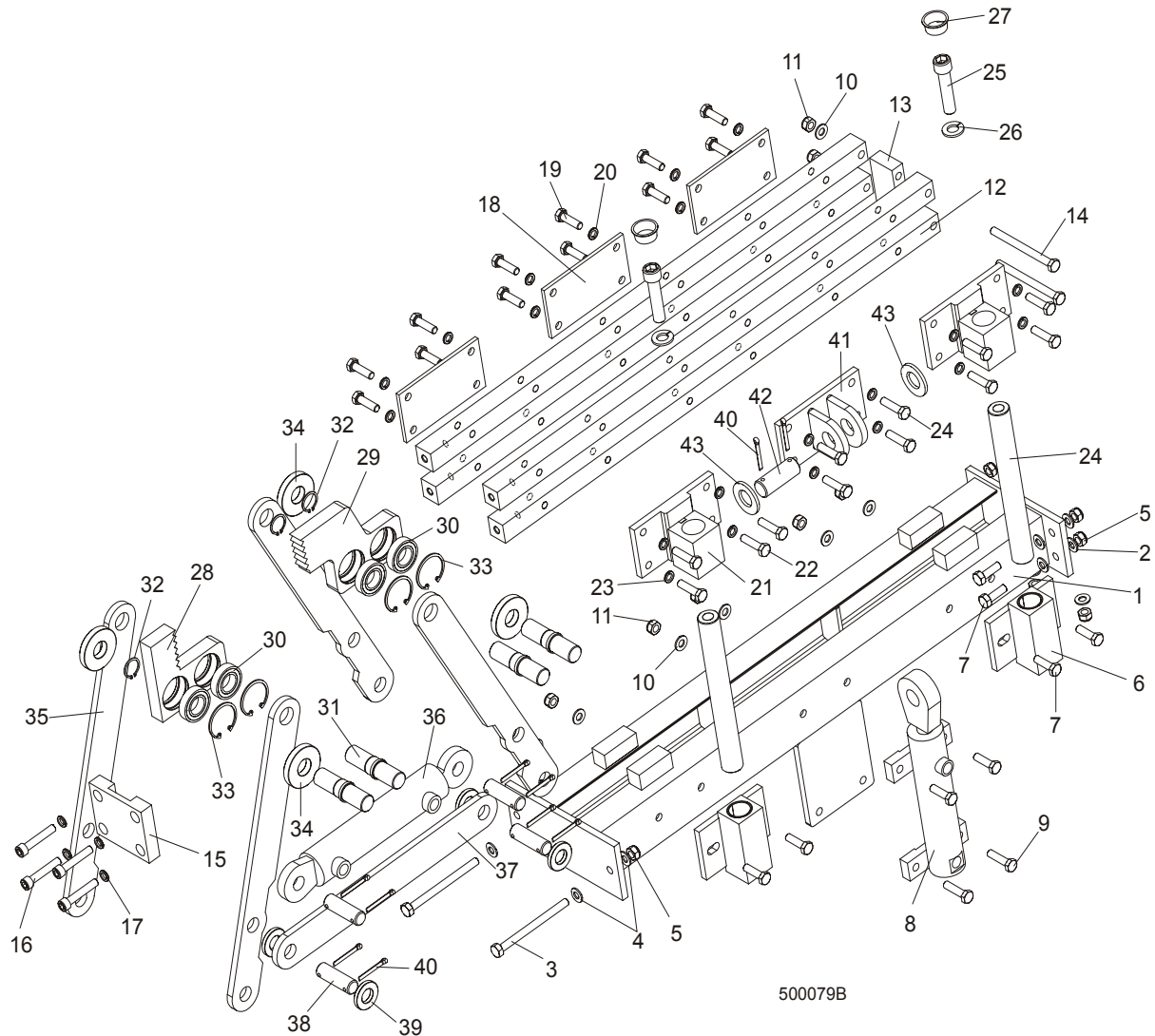

500079B

REF	DESCRIPTION (◆ Indicates Parts Available In Assemblies Only)	PART #	QTY.
	HYDRAULIC LOG CLAMP ASSEMBLY	094950	2
1	Mount Weldment, Hydraulic Log Clamp	094951-1	1
2	Washer, M10 Split Lock Zinc	F81055-2	4
3	Bolt, M10x125-8.8 Zinc Hex Head	F81003-18	2
4	Washer, 10.5 Flat Zinc	F81055-1	6
5	Nut, M10-8-B Hex Nylon Zinc Lock	F81033-1	6
6	Block Weldment, Log Clamp Up/Down Lower Painted	089835-1	2
7	Bolt, M10x35-8.8 Hex Head Full Thread Zinc	F81003-17	8
8	Cylinder, CJ7F-16-40/22 + UE2-40W Hydraulic	088662	1
9	Bolt, M10x40-8.8 Hex Head Full Thread Zinc	F81003-16	4

HYDRAULIC SYSTEM

Hydraulic Log Clamp, Optional

8

10	Washer, 10.5 Flat Zinc	F81055-1	6	
11	Nut, M10-8-B Hex Nylon Zinc Lock	F81033-1	10	
12	Bar, Log Clamp Main Painted	089537-1	4	
13	Block, Main Bar Spacer Painted	088645-1	1	
14	Bolt, M10x120-8.8 Hex Head Zinc	F81003-47	2	
15	Plate Weldment, Main Bar Mounting Painted	089533-1	1	
16	Screw, M10x40-8.8 Hex Socket Head Cap Zinc	F81003-22	4	
17	Washer, 10.2 Split Lock Zinc	F81055-2	4	
18	Plate, Log Clamp Rear Painted	089538-1	3	
19	Bolt, M10x35-8.8 Hex Head Full Thread Zinc	F81003-17	12	
20	Washer, 10.2 Split Lock Zinc	F81055-2	12	
21	Block Weldment, Log Clamp Up/Down Upper	089536-1	2	
22	Bolt, M10x40-8.8 Hex Head Full Thread Zinc	F81003-16	8	
23	Washer, 10.2 Split Lock Zinc	F81055-2	8	
24	Pin, Log Clamp Up/Down	088631	2	
25	Screw, M16x55-8.8 Hex Socket Head Cap Zinc	F81006-18	2	
26	Washer, 16.3 Split Lock Zinc	F81058-2	2	
27	Plug, M33 Thread	089839	2	
	Jaw, Log Clamp Narrow - Complete	094700	1	
28	Jaw, Log Clamp Narrow	093464-1	1	
30	Bearing, 6005 2RS CX	089652	4	
31	Shaft, Log Clamp Jaw	088620-1	4	
32	Ring, Z24 Outside Retaining	089654	4	
33	Ring, W47 Inside Retaining	089653	4	
	Jaw, Log Clamp Wide - Complete	094701	1	
29	Jaw, Log Clamp Wide	093465-1	1	
30	Bearing, 6005 2RS CX	089652	4	
31	Shaft, Log Clamp Jaw	088620-1	4	
32	Ring, Z24 Outside Retaining	089654	4	
33	Ring, W47 Inside Retaining	089653	4	
34	Washer, Clamp Jaw Spacer	089542	4	
35	Arm, Log Clamp In/Out Painted	088622-1	4	
36	Cylinder, SJ2F-40/22/145 Hydraulic	088661	1	
37	Link, Log Clamp In/Out Arm Painted	088623-1	1	
38	Pin, 20x75 Zinc-Plated	088657-1	4	
39	Washer, Lower Spacer	089541	4	
40	Washer, M20 Flat Zinc	F81059-2	10	
41	Bracket, Up/Down Cylinder Mount Upper	089540-1	1	
42	Pin, 25x75 Zinc-Plated	088659-1	1	
43	Washer 28 Fe/Zn5	F81061-1	2	

8 HYDRAULIC SYSTEM

Hydraulic Toe Board

8.8 Hydraulic Toe Board

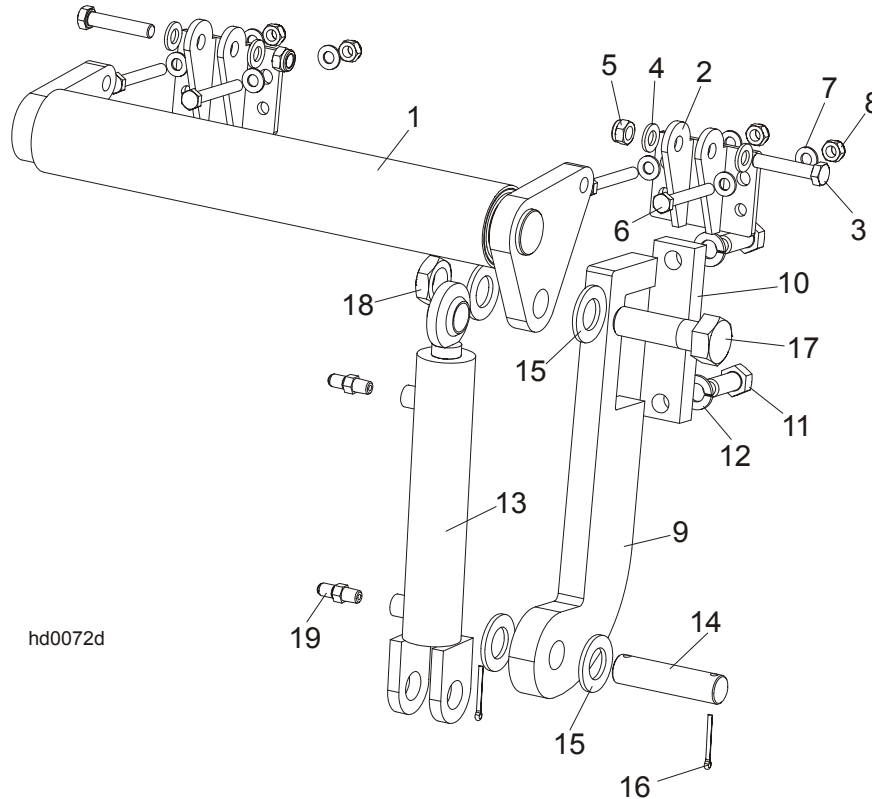

REF	DESCRIPTION (◆ Indicates Parts Available In Assemblies Only)	PART #	QTY.
	FRONT HYDRAULIC TOE BOARD	092613	1
	REAR HYDRAULIC TOE BOARD	092634	1
1	Toe Board Weldment, Front Hydraulic Painted	092612-1	1
	Toe Board Weldment, Rear Hydraulic Painted	086253-1	1
2	Bracket, Toe Board Roller Mount	087903-1	4
3	Bolt, M12x60-8.8 Hex Head Zinc	F81004-5	4
4	Washer, 13 Flat Zinc	F81056-1	8
5	Nut, M12-8 Hex Nylon Zinc Lock	F81034-2	4
6	Bolt, M10x75-8.8 Hex Head Zinc	F81003-15	8
7	Washer, 10.5 Flat Zinc	F81055-1	16
8	Nut, M10-8-B Hex Nylon Zinc Lock	F81033-1	8
9	Bracket, Toe Board Cylinder Mount Painted	087729-1	2
10	Plate, Toe Board Cylinder Mount	090086-1	2
11	Bolt, M16x40-8.8 Hex Head Full Thread Zinc	F81006-13	4
12	Washer, 16.3 Split Lock Zinc	F81058-2	4
13	Cylinder, CJ-S170-16-40/25/152 Hydraulic	088681	2
14	Pin, Hydraulic Cylinder Zinc-Plated	086979-1	2
15	Washer, 28 Flat Zinc	F81061-1	8

HYDRAULIC SYSTEM

Hydraulic Toe Board

8

16	Pin, 3/16x1.5" Cotter Zinc	F05012-23	4	
17	Bolt, 1"-8 x 3 1/4 Hex Head Grade 5	F05009-51	2	
18	Nut, 1"-14	F05010-117	2	
19	Fitting, C5205x4x4 Male	P09143	4	

8 HYDRAULIC SYSTEM

Power Toe Roller

8.9 Power Toe Roller

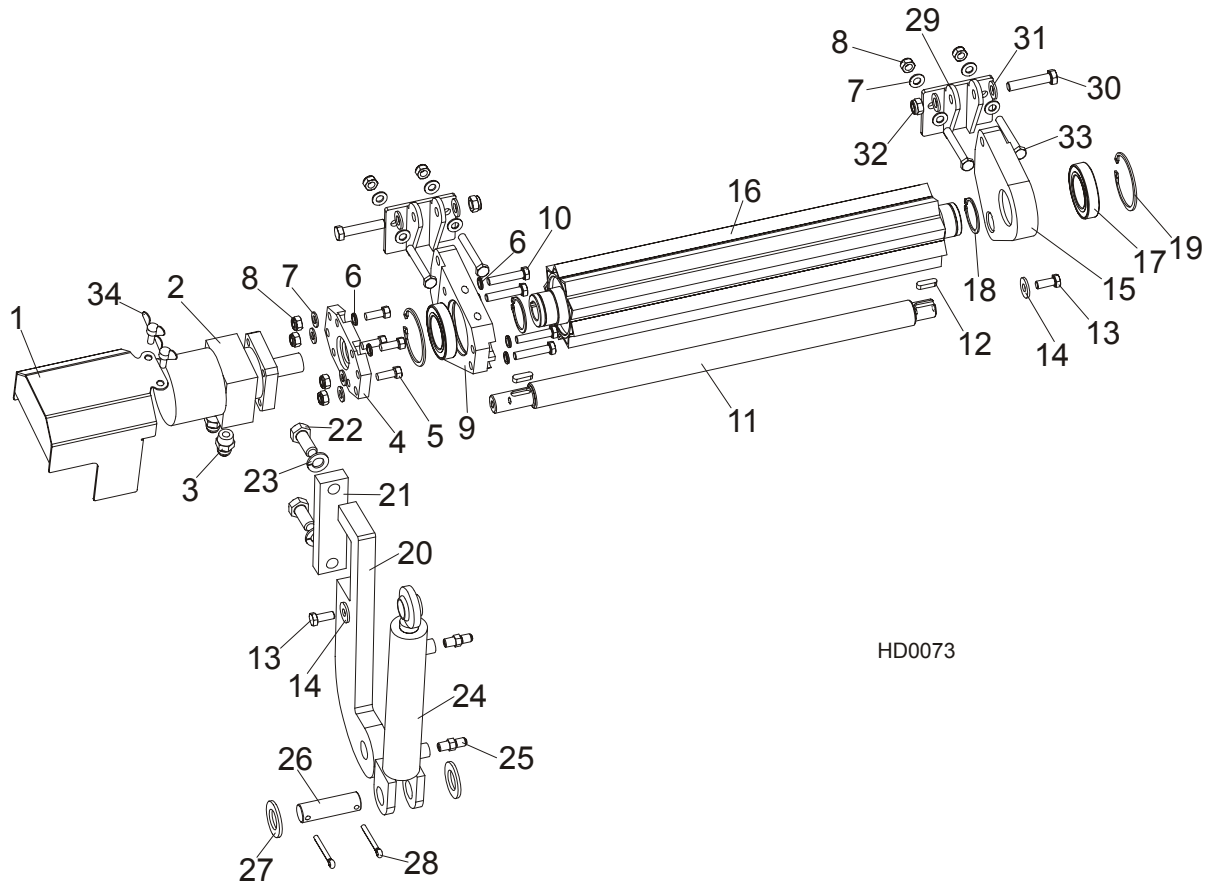

REF	DESCRIPTION (◆ Indicates Parts Available In Assemblies Only)	PART #	QTY.
	POWER ROLLER	096040	1
1	Cover, Hydraulic Motor	096037-1	1
2	Motor, MG06-13-13AAAB Hyd	P21506	1
3	Fitting, 1/2-14NPT/ 7/16-20UNF	096919	2
4	Plate, Hydraulic Motor Mount	096030-1	1
5	Screw, 3/8-16x1, HHC	F05007-7	4
6	Washer, 10.2 Split Lock Zinc	F81055-2	4
7	Washer, 10,5 Flat Zinc	F81055-1	12
8	Nut, M10-8-B Nylon Hex Zinc Lock	F81033-1	8
9	Bracket, Side w/HydroMotor Connector	096029-1	1
10	Bolt, M10x50-8.8-Hex Head Full Thread Zinc	F81003-4	4
11	Rod	096034	1
12	Key, A8x7x28 Parallel	096035	2
13	Bolt, M10x25 8.8 Hex Head Full Thread Zinc	F81003-31	2
14	Washer, 10,5 Zinc Flat Special	F81055-6	2

15	Bracket	096031-1	1	
16	Roller, Pivot - Wldmt	096028-1	1	
17	Bearing, 6009.2RSR	096025	2	
18	Ring, Z 45 Spring Retaining	F81090-32	2	
19	Ring, W 75 Spring Retaining	F81090-41	2	
20	Plate, Toe Board Cylinder Mount	087729-1	1	
21	Plate, Hydraulic Toe Board Mount	090086-1	1	
22	Bolt, M16x40-8.8 Hex Head Full Thread Zinc	F81006-13	2	
23	Washer, 16,3 Split Lock Zinc	F81058-2	2	
	Cylinder, Hydraulic Toe Boards	085937	1	
24	Cylinder, CJ-S170-16-40/25/152 Hydraulic	088681	1	
25	Fitting, C5205x4x4 Male	P09143	2	
26	Pin, Hydraulic Cylinder Zinc	086979-1	1	
27	Washer, 28 Flat Zinc	F81061-1	2	
28	Pin, S-Zn 6,3x45	F81045-2	2	
29	Bracket, Toe Board Roller Mount	087903-1	2	
30	Bolt, M12x60-8.8 Hex Head Zinc	F81004-5	2	
31	Washer, 13 Zinc Flat	F81056-1	4	
32	Nut, M12-8 Hex Nylon Zinc Lock	F81034-2	2	
33	Bolt, M10x75-8.8-Hex Head Zinc	F81003-15	4	
34	Stud, M6x16 Wing	F81001-16	2	

8.10 Hydraulic Pump & Tank

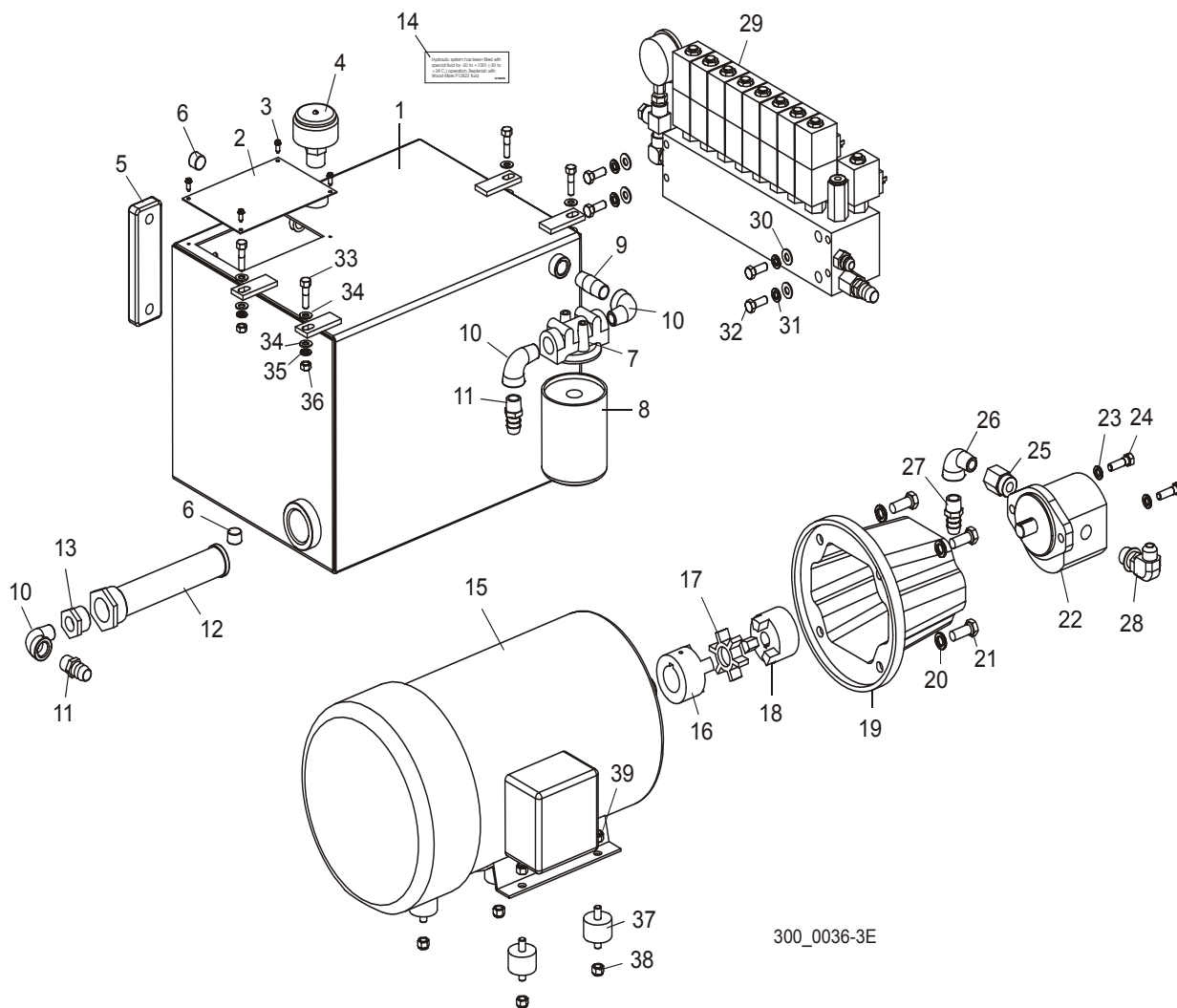

REF	DESCRIPTION (◆ Indicates Parts Available In Assemblies Only)	PART #	QTY.
	TANK ASSEMBLY, HYDRAULIC 10 GALLON	045093	1
1	Tank Weldment, 10 Gallon	045249	1
2	Cover, Hydraulic Tank Access	S20331	1
3	Bolt, #8-32 x 1/2" Slotted Hex Head	F05015-18	4
4	Cap, Hydraulic Breather/Filter	P20212	1
5	Guage, Hydraulic Fluid	P20211	1
6	Fitting, 1/2" NPT Pipe Plug	P26258	2
7	Filter Assembly, Hydraulic Manifold	P22683	1
8	Filter, S28 Hydraulic	P20301	1
9	Fitting, 1/2" NPT x 2" Black Pipe Nipple	016844	1

10	Fitting, 1/2" NPT ST Galvanized Elbow	P22684	3	
11	Fitting, 1/2" NPT Male x 3/4" Hose Barb	035621	2	
12	Filter, Hydraulic Tank Suction	P20210	1	
13	Fitting, 1/2" x 1" Reducer Bushing	P20239	1	
14	Decal, Hydraulic Fluid Replacement	S12825	1	
	PUMP ASSEMBLY, 50/60HZ HYDRAULIC	042780	1	
15	Motor, 7 1/2 HP 213TC 50/60Hz 415/480V	042776	1	
16	Coupling, L100 x 1 3/8" Body	042777	1	
17	Coupling, L100 Spider	042779	1	
18	Coupling, L100 x 3/4" Body	042778	1	
19	Adaptor, Hydraulic Pump/50Hz Motor	042781	1	
20	Washer, 1/2" Split Lock	F05011-9	4	
21	Bolt, 1/-13 x 1 1/4" Hex Head Grade 5	F05008-37	4	
22	Pump, 6 GPM Hydraulic 50Hz	042782	1	
23	Washer, 3/8" Split Lock	F05011-4	2	
24	Bolt, 3/8-16 x 1 1/4" Hex Head Grade 5	F05007-123	2	
25	Fitting, 1/2" NPT x #12 SAE Female Adaptor	042785	1	
26	Fitting, 1/2" NPT Galvanized Elbow	P22684	1	
27	Fitting, 1/2" NPT x 3/4" Hose Barb	035621	1	
28	Fitting, #10 SAE x 1/2" JIC 90° Elbow	042784	1	
29	VALVE PARTS (See Section 8.2)			
30	WASHER, 3/8" SAE FLAT	F05011-3	4	
31	WASHER, 3/8" SPLIT LOCK	F05011-4	4	
32	BOLT, 3/8-16 X 1" HEX HEAD GRADE 5	F05007-87	4	
33	BOLT, 5/16-18 X 1 1/4" HEX HEAD	F05009-62	4	
34	WASHER, 5/16" SAE FLAT	F05011-17	8	
35	WASHER, 5/16" SPLIT LOCK	F05011-13	4	
36	NUT, 5/16-18 HEX	F05010-17	4	
37	MOUNT, RUBBER HYDRAULIC MOTOR	035546	4	
38	NUT, 3/8-16 HEX NYLON LOCK	F05010-10	8	

SECTION 9 MISCELLENEOUS

9.1 Lube System

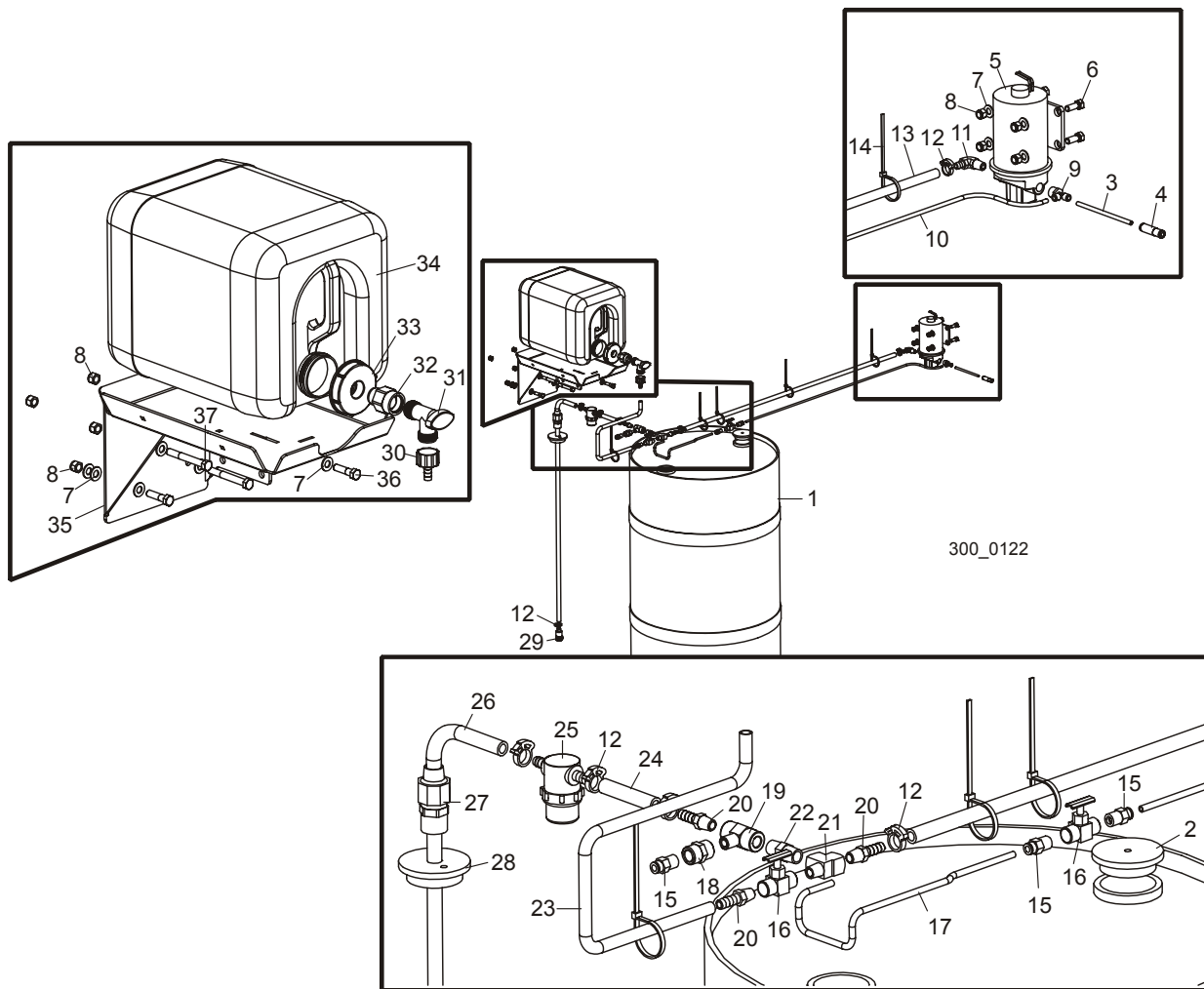

REF	DESCRIPTION (◆ Indicates Parts Available In Assemblies Only)	PART #	QTY.
	LUBE, 5 GALLON #9 BLADE	016853	1
	LUBE SYSTEM, LT300 BLADE	016926	1
1	Barrel, Plastic	016784	1
2	Cap, Barrel Vent	016786	1
3	Hose, 1/4" x 100 Foot	016944	1
4	Fitting, 1/4" Tube 6 PSI Check Valve	016827	1
	Cable Assembly, Lube Power	025249	1
	Pump Assembly, LT300 Lube	016883	1
5	Pump Assembly, Lube w/Wires	050029	1

6	Bolt, 3/8-16 x 1" Hex Head Grade 5	F05007-87	4	
7	Washer, 3/8" Flat	F05011-3	10	
8	Nut, 3/8-16 Hex Nylon Lock	F05010-10	8	
9	Fitting, 3/8" NPT x 1/4" Tube Male Run Tee	016961	1	
10	Hose, 1/4" x 40"	016885	1	
11	Fitting, 3/8" NPT x 3/8" Hose Barb Elbow	P12709	1	
12	Clamp, Single Snap Grip #38	016845	6	
13	Hose, 3/8" x 44"	016829	1	
14	Tie Wrap, 3/16" x 5 1/2" UV Black	F05089-3	6	
15	Fitting, 1/4" NPT x 1/4" Tube Straight	P20903	3	
16	Valve, 1/4" NPT Female Needle	051392	2	
17	Hose, 1/4" x 24"	016886	1	
18	Fitting, 1/4" NPT Coupling	P03420	1	
19	Fitting, 1/4" NPT Branch Tee	015486	1	
20	Fitting, 1/4" NPT x 3/8" Hose Barb	014685	3	
21	Fitting, 1/4" NPT Male x 1/4" Female x 2	P05382	1	
22	Fitting, 1/4" NPT Nipple	P21524	1	
23	Hose, 3/8" ID x 25" Tygothane	038495	1	
24	Hose, 3/8" x 3"	038494	1	
25	Filter, 3/8" Hose Barb Lube	033447	1	
26	Hose, 3/8" x 40"	016884	1	
27	Fitting, 1/2" x 1/2" Compression Coupler	016935	1	
28	Cap, Barrel Vent	016785	1	
29	Fitting, 3/8" Barb Foot Check Valve	016939	1	
30	Fitting, 5/8" NPT x 3/8" Hose Barb	014113	1	
31	Valve, 3/4" NPT Elbow PVC	014100	1	
32	Fitting, 3/4" FPT x 3/4" MPT	014636	1	
33	Cap, 70mm Bottle (Modified)	036744	1	
34	Bottle, 5 Gallon Plastic	014637	1	
35	Bracket, Auxiliary Tank Mount	038498	1	
36	Bolt, 3/8-16 x 1 1/2" Hex Head Grade 5	F05007-78	2	
37	Bolt, 3/8-16 x 3" Hex Head Grade 5	F05007-73	2	

9.2 Pressure Lube System (Optional)

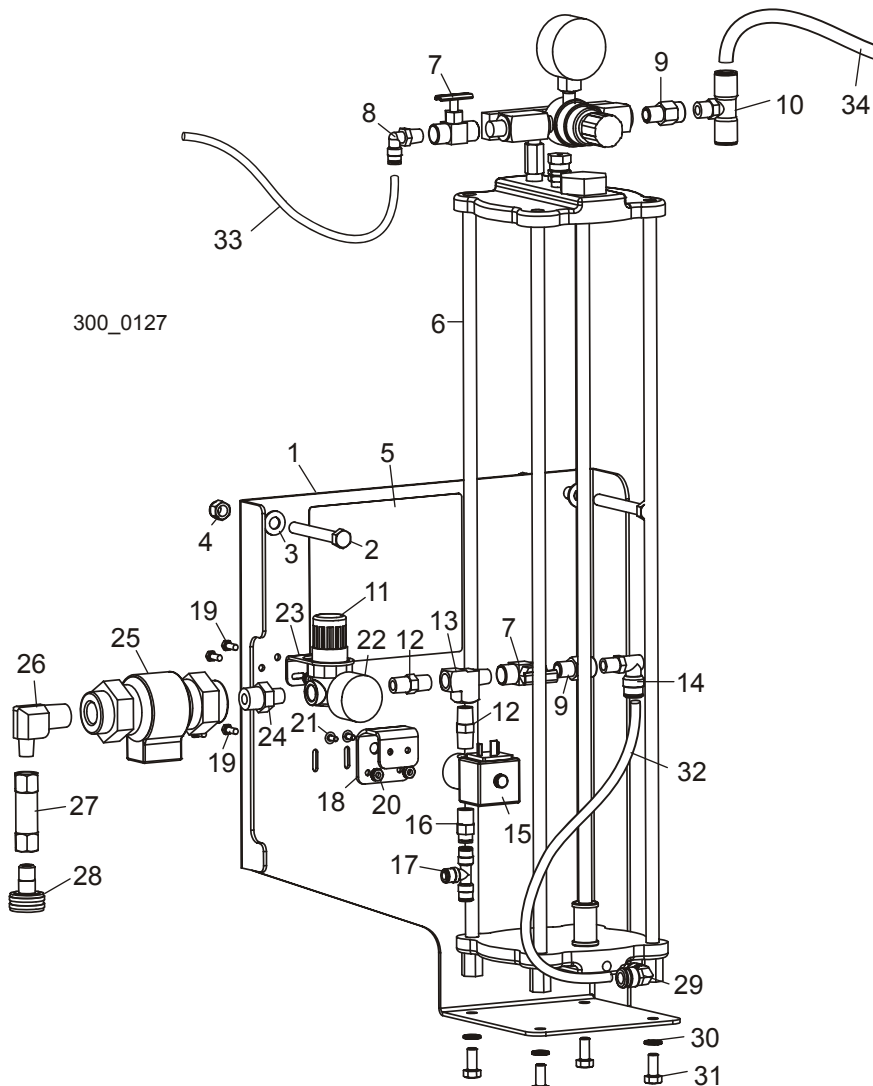

REF	DESCRIPTION (◆ Indicates Parts Available In Assemblies Only)	PART #	QTY.
	LUBE SYSTEM, LT300 OPTIONAL PRESSURE BLADE	051431	1
1	Bracket, Pressure Lube Mount	036685	1
2	Bolt, 3/8-16 x 3" Hex Head Full Thread	F05007-1	2
3	Washer, 3/8" SAE Flat	F05011-3	2
4	Nut, 3/8-16 Hex Nylon Lock	F05010-10	2
5	Decal, Pressure Lube Layout	036747	1
6	Reservoir Assembly, Pressure Lube	051434	1
7	Valve, 1/4" NPT Brass Female Needle	051392	2
8	Fitting, 1/4" NPT x 1/4" Tube 90° Elbow Air	P21519	1
9	Valve, 1/4" NPT Male-Female Check	051394	2

10	Fitting, 1/4" NPT x 1/2" Tube Tee	038737	1	
11	Regulator, 1/4" NPT 125 PSI Water	051427	1	
12	Fitting, 1/4" NPT Hex Pipe Nipple	P05389	2	
13	Fitting, 1/4" NPT Female-Male-Female Tee	P05382	1	
14	Fitting, 1/4" NPT x 3/8" Tube 90° Elbow Air	P21521	1	
15	Valve, 1/4" NPT Water NC 2-Way Solenoid	051432	1	
	Cable Assembly, LT300 Lube Pump	052222	1	
16	Fitting, 1/4" NPT x 1/4" Tube Straight Air	P20903	1	
17	Fitting, 1/4" Tube Air Tee	P21544	1	
18	Bracket, Solenoid Mount	036688	1	
19	Screw, #10-24 x 1/2" Unslotted Hex Stainless Steel	F05004-27	4	
20	Nut, #10-24 Self-Locking Hex	F05010-14	4	
21	Screw, #8-32 x 3/8" Round Head Grade 5	F05004-157	2	
22	Gauge, 160 PSI	P02766	1	
23	Bracket, Regulator Mount	051429	1	
24	Fitting, 1/2" NPT x 1/4" NPT Hex Nipple	038484	1	
25	Valve, 1/2" NPT Vacuum Break Dual Check	038483	1	
26	Fitting, 1/2" NPT x 1/4" NPT 90° Elbow	016881	1	
27	Strainer, 1/4" NPT 100 Mesh Inline	051882	1	
28	Fitting, 1/4" NPT x Female Water Hose	051433	1	
29	Fitting, 1/8" NPT x 3/8" Tube 90° Elbow	P21552	1	
30	Washer, 5/16" Split Lock	F05011-13	4	
31	Bolt, 5/16-24 x 3/4" Hex Head Grade 5 Full Thread	F05006-105	4	
32	Tubing, 1/4" Air	R01869	2 ft.	
33	Tubing, 3/8" Air	R01869-1	5.147 ft.	
34	Tubing, 1/2" Air	R01869-2	3 ft.	

9.3 Tools

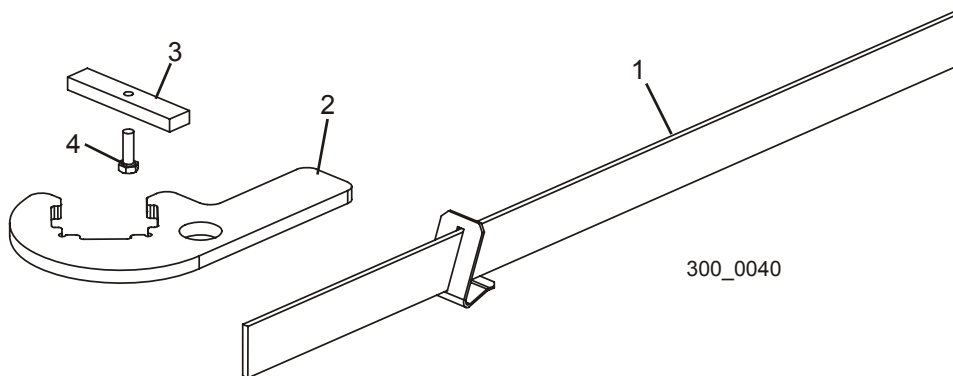

REF	DESCRIPTION (◆ Indicates Parts Available In Assemblies Only)	PART #	QTY.	
1	ALIGNMENT TOOL, BLADE GUIDE	LTBGAT	1	
2	ALIGNMENT TOOL, BLADE GUIDE ARM	042700	1	
3	BLOCK, BLADE GUIDE ALIGNMENT	035799	2	
4	BOLT, #10-32 X 5/8" HEX HEAD	F05004-152	2	
	HONE, 6" COURSE DIAMOND BENCH SHARPENING (NOT SHOWN)	017813	1	

9.4 Manuals

REF	DESCRIPTION (◆ Indicates Parts Available In Assemblies Only)	PART #	QTY.	
LT300 Manuals				
1	MANUAL, LT300 OPERATOR'S	M988	1	
2	MANUAL, LT300 PARTS	M991	1	
Option Manuals				
3	MANUAL, IC1 INCLINE CONVEYOR OPTION	M1019	1	
4	MANUAL, TD1 TRANSFER DECK OPTION	M1020	1	
5	MANUAL, LD12/LD20 LOG INFEEDECK OPTION	M1024	1	
Schematics				
6	SCHEMATIC, LT300 ELECTRICAL	M1014	1	
7	SCHEMATIC, LT300 AIR	M1015	1	
8	SCHEMATIC, INCLINE CONVEYOR ELECTRICAL	M1029	1	
9	SCHEMATIC, TRANSFER DECK ELECTRICAL	M1030	1	

10

Operator Station Frame, Rails & Ladder

SECTION 10 OPERATOR STATION

10.1 Frame, Rails & Ladder

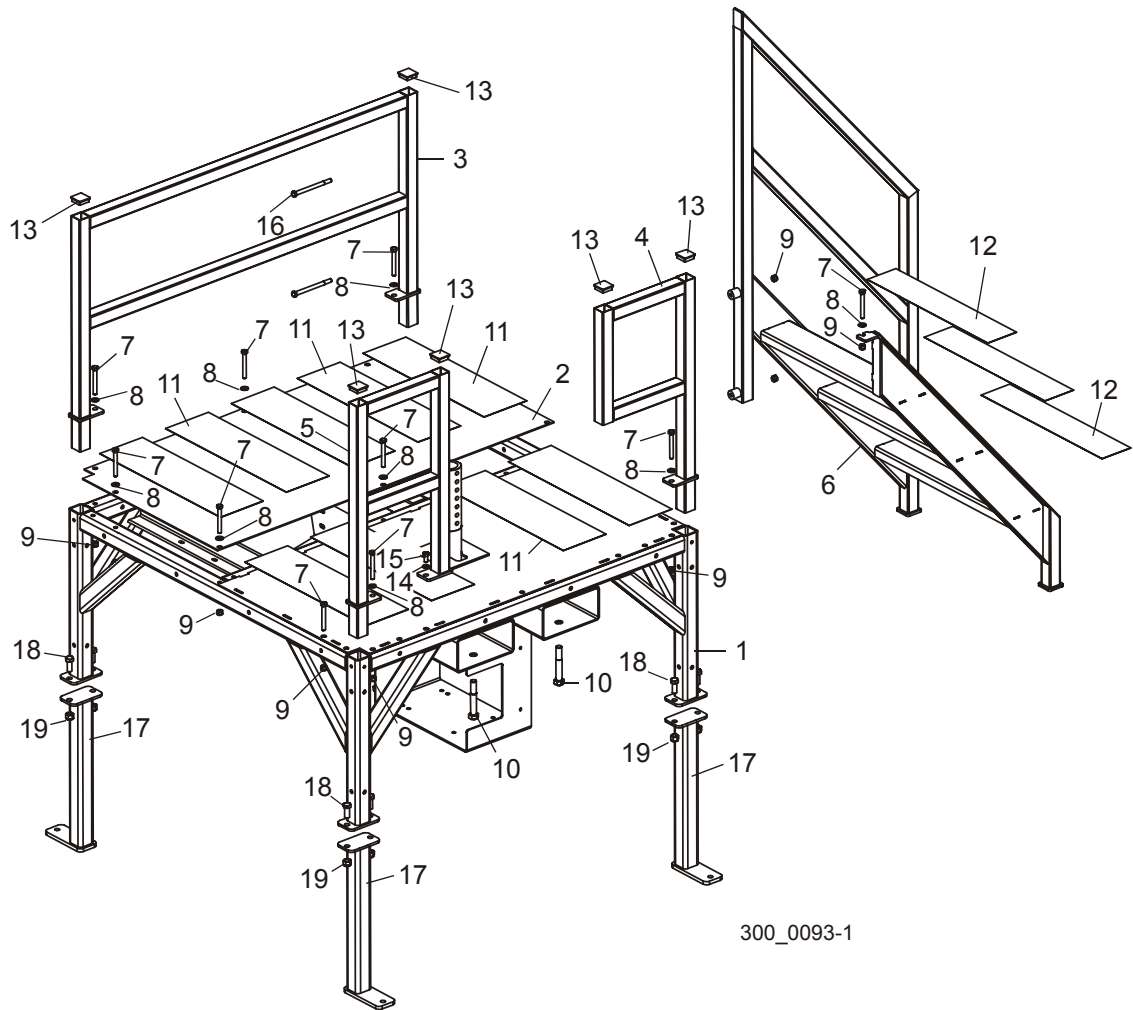

300_0093-1

REF	DESCRIPTION (◆ Indicates Parts Available In Assemblies Only)	PART #	QTY.
1	FRAME WELDMENT, OPERATOR STATION	045110	1
2	PLATE, WALKWAY	045114	1
3	RAIL WELDMENT, LONG	045118	1
4	RAIL WELDMENT, SHORT	045119	1
5	RAIL WELDMENT, LEFT REAR	036360	1
6	LADDER WELDMENT, OPERATOR STATION	036474	1
7	BOLT, 3/8-16 X 3" HEX HEAD FULL THREAD	F05007-1	10
8	WASHER, 3/8" SAE FLAT	F05011-3	9
9	NUT, 3/8-16 HEX NYLON LOCK	F05010-10	12

10	BOLT, 5/8-11 X 4" HEX HEAD FULL THREAD GRADE 5	F05009-8	2	
11	PAD, NON-SKID	045149	15 Ft.	
12	PAD, NON-SKID STEP	016895	3	
13	PLUG, 1 1/2" SQUARE 14 GA. WALL CAP	016843	6	
14	WASHER, 3/8" SPLIT LOCK	F05011-4	1	
15	BOLT, 3/8-16 X 3/4" HEX HEAD GRADE 5	F05007-118	1	
16	BOLT, 3/8-16 X 5" HEX HEAD GRADE 5	F05007-86	2	
	LEG ASSEMBLY, 18" EXTENSION	036461	4	
17	Leg Weldment, Operator Station 18" Extension	051353	1	
18	Bolt, 1/2-13 x 1 1/4" Hex Head Grade 5	F05008-37	2	
19	Nut, 1/2-13 Hex Nylon Lock	F05010-8	2	

10.2 Seat & Joystick Controls

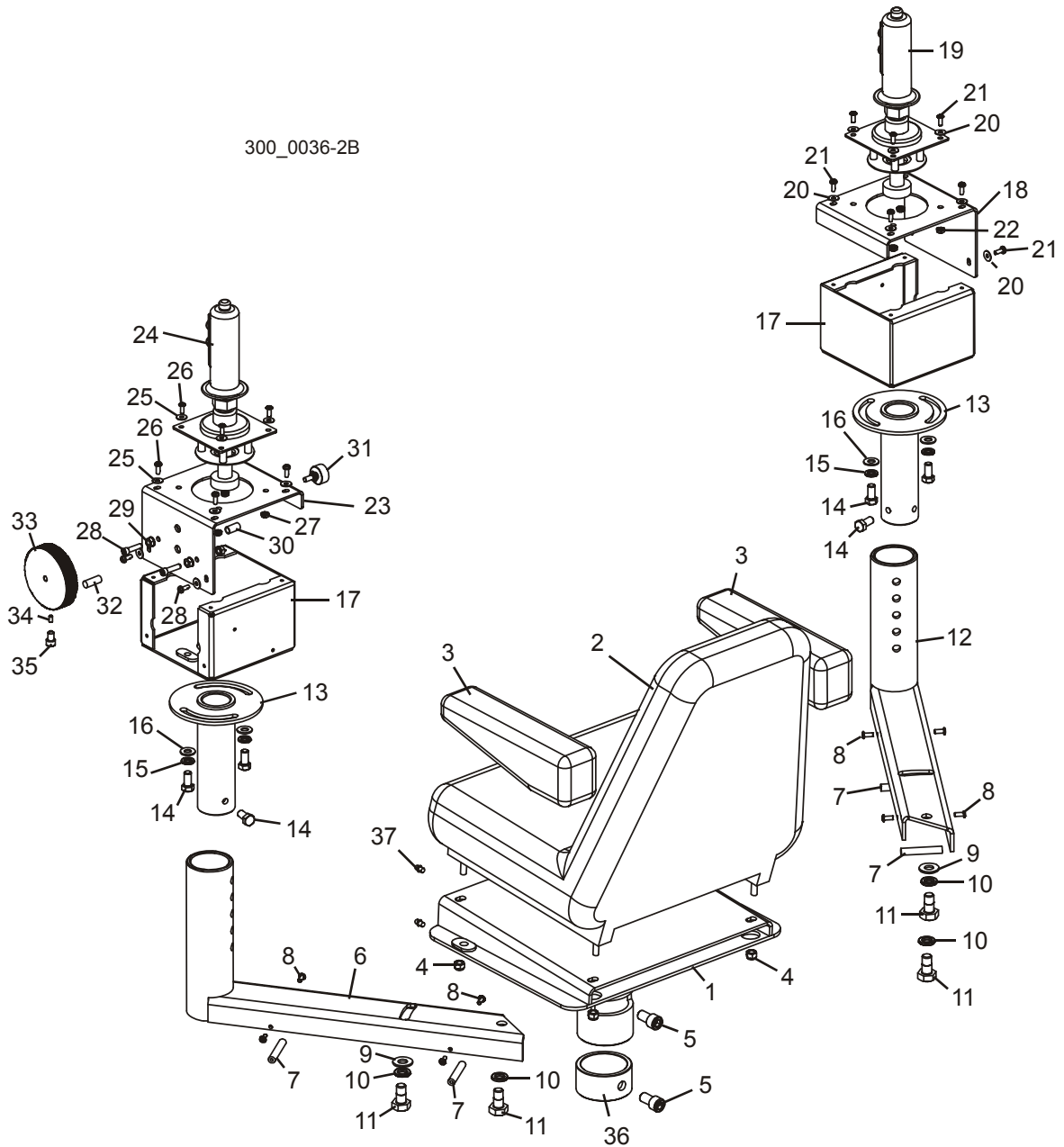

REF	DESCRIPTION (◆ Indicates Parts Available In Assemblies Only)	PART #	QTY.
1	MOUNT WELDMENT, OPERATOR SEAT	045134	1
2	SEAT, OPERATOR	038719	1
3	ARMREST, OPERATOR SEAT (PAIR)	038721	1
4	NUT, 5/16-18 NYLON LOCK	F05010-58	4
5	BOLT, 1/2-20 X 1" SOCKET HEAD	F05008-57	2

6	ARM WELDMENT, LEFT CONTROL	045144	1	
7	PIN, HARNESS SUPPORT	045148	4	
8	SCREW, #10-24 X 1/2" SOCKET BUTTON HEAD	F05004-35	8	
9	WASHER, 1/2" SAE FLAT	F05011-2	2	
10	WASHER, 1/2" SPLIT LOCK	F05011-9	4	
11	BOLT, 1/2-13 X 1" HEX HEAD	F05008-50	4	
12	ARM WELDMENT, RIGHT CONTROL	045145	1	
13	TUBE WELDMENT, JOYSTICK MOUNT	042105	2	
14	BOLT, 3/8-16 X 3/4" HEX HEAD GRADE 5	F05007-118	6	
15	WASHER, 3/8" SPLIT LOCK	F05011-4	4	
16	WASHER, 3/8" SAE FLAT	F05011-3	4	
17	BOX WELDMENT, JOYSTICK	042103	2	
	CONTROL ASSEMBLY, RIGHT JOYSTICK	035541	1	
18	Cover, Joystick Control Box	035542	1	
19	Joystick, 3-Button Control	036757	1	
20	Washer, #10 SAE Flat	F05011-18	10	
21	Screw, #10-24 x 1/2" Phillips Head	F05015-17	6	
22	Nut, #10-24 Self-Locking Hex	F05010-14	4	
	CONTROL ASSEMBLY, LEFT JOYSTICK	035547	1	
23	Cover Weldment, Joystick Control Box	035543	1	
24	Joystick, 3-Button Control	036757	1	
25	Washer, #10 SAE Flat	F05011-18	10	
26	Screw, #10-24 x 1/2" Socket Button Head	F05004-35	10	
27	Nut, #10-24 Self-Locking Hex	F05010-14	4	
28	Bolt, 1/4-20 x 1" Socket Head	F05005-84	2	
29	Nut, 1/4-20 Self-Locking Hex	F05010-9	4	
30	Spring, LC-040E-10SS	P06460	1	
31	Potentiometer Assembly, 4-20mA 24V w/Connectors	025200	1	
32	Pin, Cam Brake	S10663	1	
33	Knob, Speed Control	035559	1	
34	Screw, #10-32 x 3/8" Cup Point Socket Set	F05004-18	1	
35	Bolt, 5/16-18 x 1/2" Socket Head	F05006-39	1	
36	Collar, Seat Post Mount	045135	1	
37	Fitting, 1/4-28 Grease	P05060	2	

10.3 Air Supply

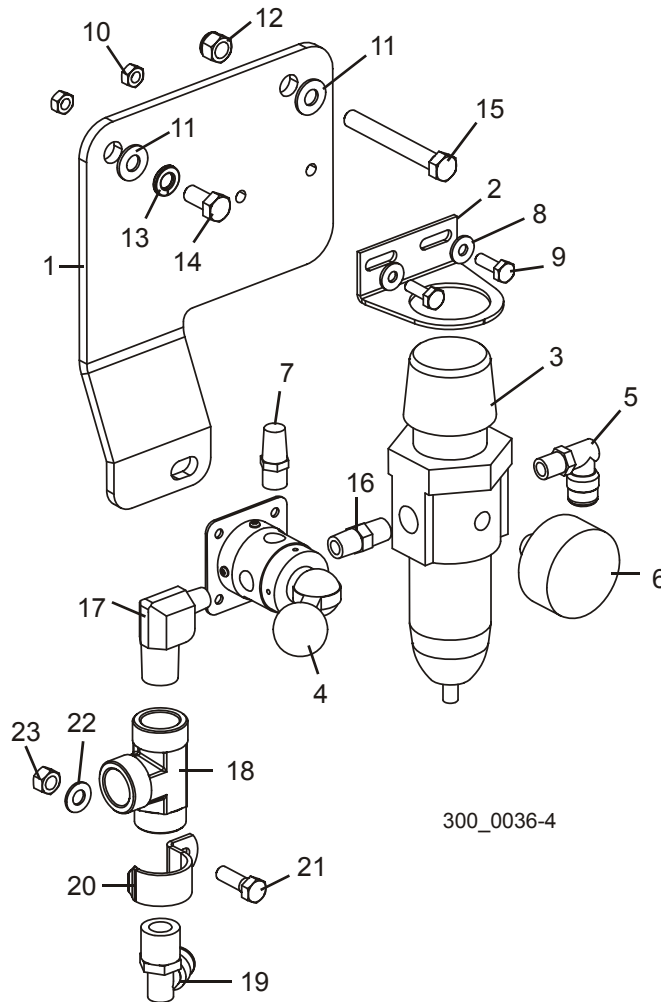

REF	DESCRIPTION (◆ Indicates Parts Available In Assemblies Only)	PART #	QTY.
	AIR SUPPLY, LT300	016887	1
1	Plate, Air Supply Mount	016888	1
2	Bracket, Air Filter Mount	P21511	1
3	Filter, B11-02 WJC Regulator	P21510	1
4	Valve, 250V3 Air	P21513	1
5	Fitting, 1/4" NPT x 3/8" Air 90° Elbow	P21521	1
6	Gauge, Air Pressure	P21512	1
7	Fitting, 1/4" NPT Air Muffler	P20904	1
8	Washer, 1/4" SAE Flat	F05011-11	2
9	Bolt, 1/4-20 x 3/4" Hex Head Full Thread	F05005-1	2
10	Nut, 1/4-20 Hex Lock	F05010-21	2
11	Washer, 3/8" SAE Flat	F05011-3	2

12	Nut, 3/8-16 Nylon Lock	F05010-10	1	
13	Washer, 3/8" Split Lock	F05011-4	1	
14	Bolt, 3/8-16 x 3/4" Hex Head Grade 5	F05007-118	1	
15	Bolt, 3/8-16 x 3" Hex Head Full Thread	F05007-1	1	
16	Fitting, 1/4" Hex Pipe Nipple	P05389	1	
17	Fitting, 1/2" NPT x 1/4" NPT 90° Elbow	016881	1	
18	Fitting, 1/2" NPT Female Tee	016793	1	
19	Fitting, 1/2" NPT x 1/2" Air 90° Elbow	016880	1	
20	Clamp, 1" EMT	P05436	1	
21	Bolt, 5/16-18 x 1" Hex Head	F05006-1	1	
22	Washer, 5/16" SAE Flat	F05011-17	1	
23	Nut, 5/16-18 Hex Lock	F05010-6	1	

SECTION 11 CAB OPTION

11.1 Cab

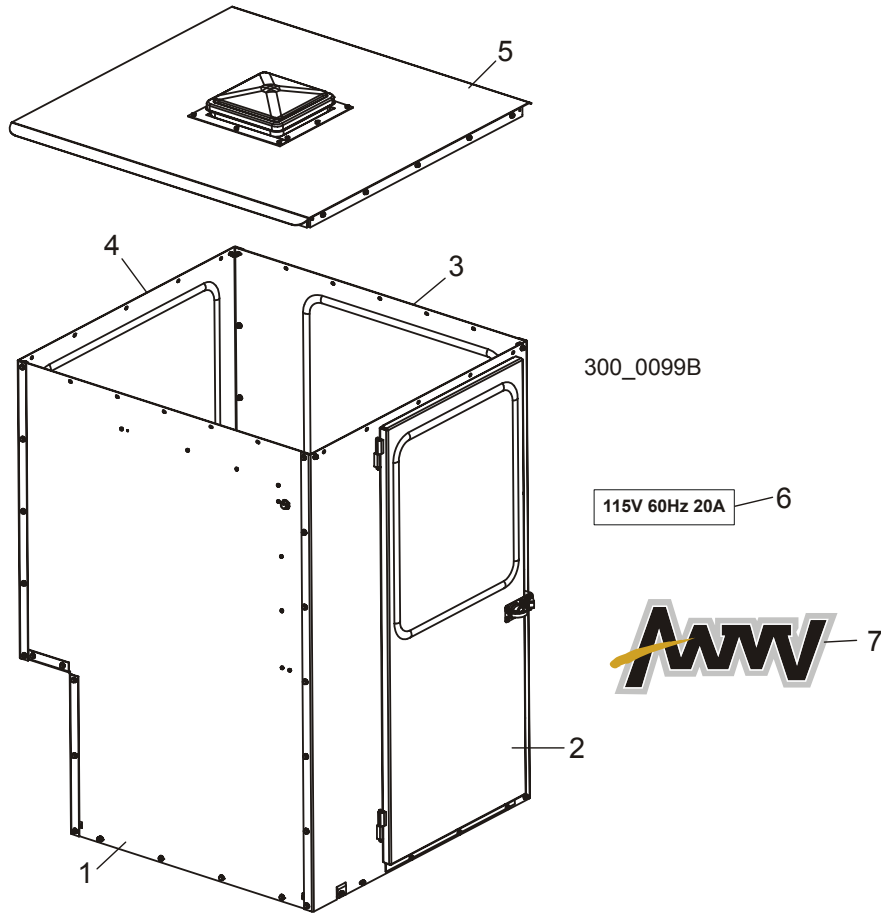

REF	DESCRIPTION (◆ Indicates Parts Available In Assemblies Only)	PART #	QTY.	
	CAB OPTION, LT300	CAB2	1	
1	Rear Panel Parts (See Section 11.2)			
2	Right Panel Parts (See Section 11.3)			
3	Front Panel Parts (See Section 11.4)			
4	Left Panel Parts (See Section 11.5)			
5	Roof Parts (See Section 11.6)			
6	Decal, Cab Voltage	042676	1	
7	Decal, AWMV Logo 18"	052269	1	

11.2 Rear Panel

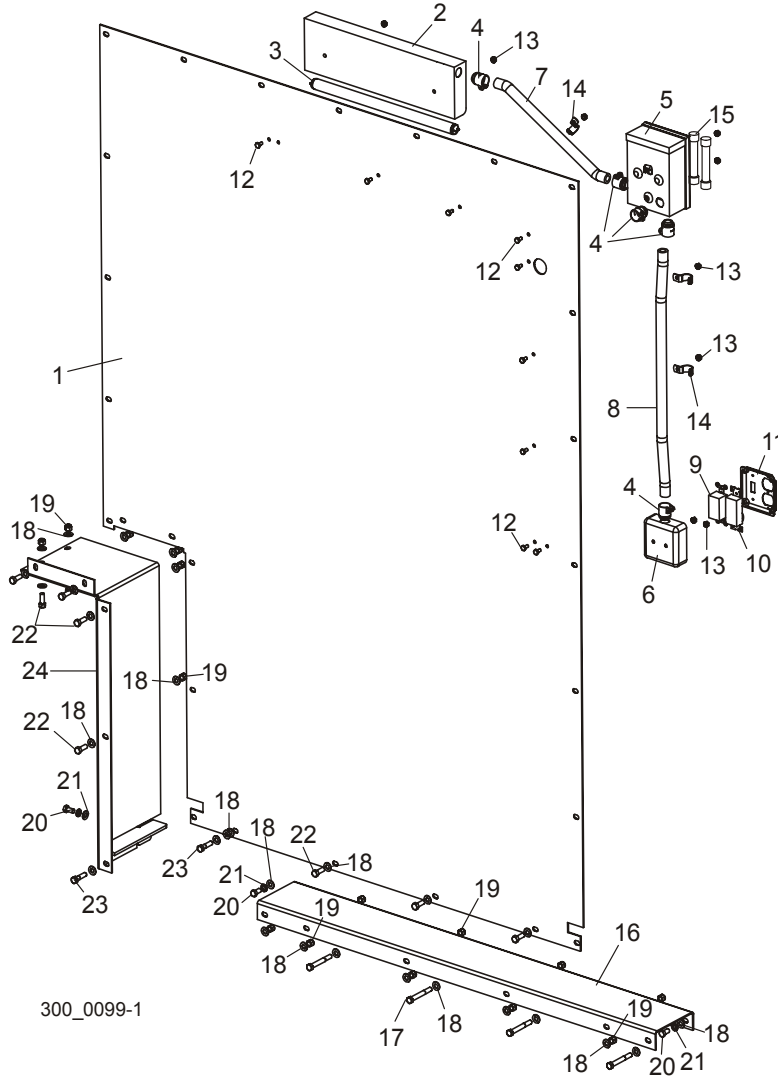

REF	DESCRIPTION (◆ Indicates Parts Available In Assemblies Only)	PART #	QTY.
	PANEL ASSEMBLY, CAB2 REAR	036602	1
1	Panel, Cab2 Rear	036601	1
2	Fixture, Fluorescent Under-Cabinet Light	042590	1
3	Bulb, 15 Watt Fluorescent	016876	1
4	Clamp, 1/2" Flex Conduit	042595	4
5	Camp, 1/2" 90° Flex Conduit	017801	1
6	Disconnect Box, Fusible 2-Wire 240V 30A	042589	1
7	Box, 4" Electrical Utility	042591	1
8	Conduit, 1/2" x 22" Steel Flex	042597	1
9	Conduit, 1/2" x 25" Steel Flex	042596	1

10	Switch, 120VAC 20 Amp Single Pole	042592	1	
11	Receptacle, 120VAC 20 Amp Duplex	042593	1	
12	Cover, Stainless Steel Switch/Plug	042594	1	
13	Bolt, 1/4-20 x 1/2" Hex Head	F05005-15	9	
14	Nut, 1/4-20 Self-Locking Hex	F05010-9	9	
	Wire Nut, Yellow	016863	6	
15	Clamp, 3/4" EMT	P04851	3	
16	Fuse, 20 Amp 250 Volt	E03743	2	
17	CHANNEL WELDMENT, REAR FLOOR	042628	1	
18	BOLT, 3/8-16 X 3" HEX HEAD GRADE 5	F05007-73	4	
19	WASHER, 3/8" SAE FLAT	F05011-3	31	
20	NUT, 3/8-16 HEX NYLON LOCK	F05010-10	15	
21	BOLT, 3/8-16 X 3/4" HEX HEAD	F05007-27	3	
22	WASHER, 3/16" SPLIT LOCK	F05011-4	3	
23	BOLT, 3/8-16 X 1" HEX HEAD	F05007-7	9	
24	BOLT, 3/8-16 X 1 1/2" HEX HEAD GRADE 5	F05007-78	2	
25	PLATE WELDMENT, LOWER LEFT	036591	1	

11.3 Right Panel

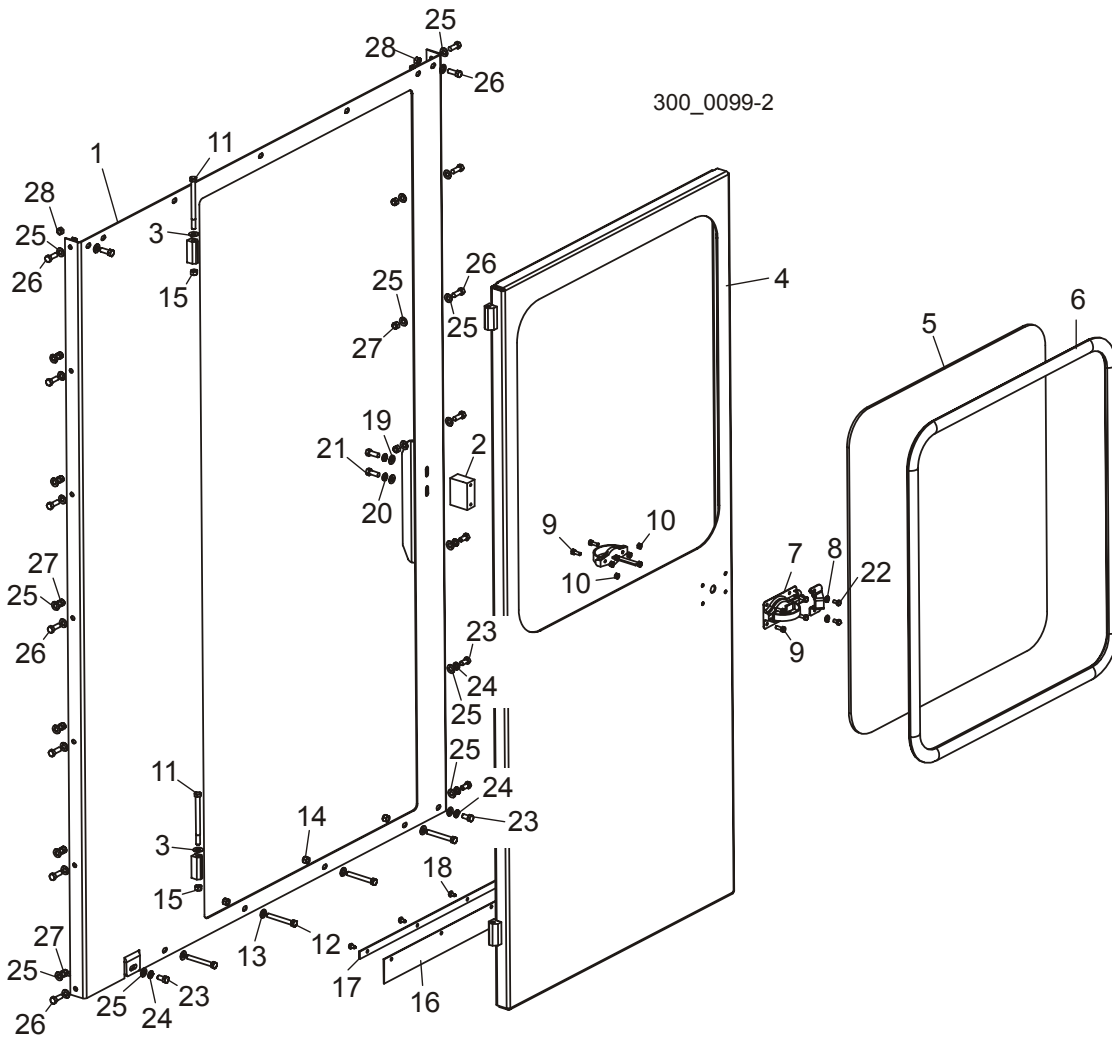

REF	DESCRIPTION (◆ Indicates Parts Available in Assemblies Only)	PART #	QTY.
	PANEL ASSEMBLY, CAB2 RIGHT	036586	1
1	Panel Weldment, Cab2 Right	036585	1
2	Block, Latch Mount	042634	1
3	Washer, Door Hinge	042578	1
4	Door Weldment, Cab	042632	1
5	Window, Cab Door	042576	1
6	Seal, Cab Door Window	042575	1
7	Latch, Door	042587	1
8	Washer, 1/4" Split Lock	F05011-14	2
9	Bolt, 1/4-20 x 3/4" Hex Head Full Thread	F05005-1	6
10	Nut, 1/4-20 Hex Lock	F05010-21	6

11	Bolt, 3/8-16 x 5" Hex Head Grade 5	F05007-86	2	
12	Bolt, 3/8-16 x 3" Hex Head Full Thread	F05007-1	4	
13	Washer, 3/8" SAE Flat	F05011-3	4	
14	Nut, 3/8-16 Hex Nylon Lock	F05010-10	4	
15	Nut, 3/8-16 Hex Lock	F05010-25	2	
16	Flap, Rubber Door	042638	1	
17	Plate, Rubber Door Flap	042637	1	
18	Screw, 1/4-20 x 1/2" Self-Tapping	F05015-1	5	
19	Washer, 3/8" SAE Flat	F05011-3	2	
20	Washer, 3/8" Split Lock	F05011-4	2	
21	Bolt, 3/8-16 x 1" Hex Head	F05007-7	2	
22	Bolt, 1/4-20 x 1/2" Hex Head	F05005-15	2	
23	BOLT, 3/8-16 X 3/4" HEX HEAD	F05007-27	5	
24	WASHER, 3/8" SPLIT LOCK	F05011-4	5	
25	WASHER, 3/8" SAE FLAT	F05011-3	27	
26	BOLT, 3/8-16 X 1" HEX HEAD	F05007-7	13	
27	NUT, 3/8-16 HEX NYLON LOCK	F05010-10	9	
28	NUT, 3/8-16 HEX LOCK	F05010-25	4	

11.4 Front Panel

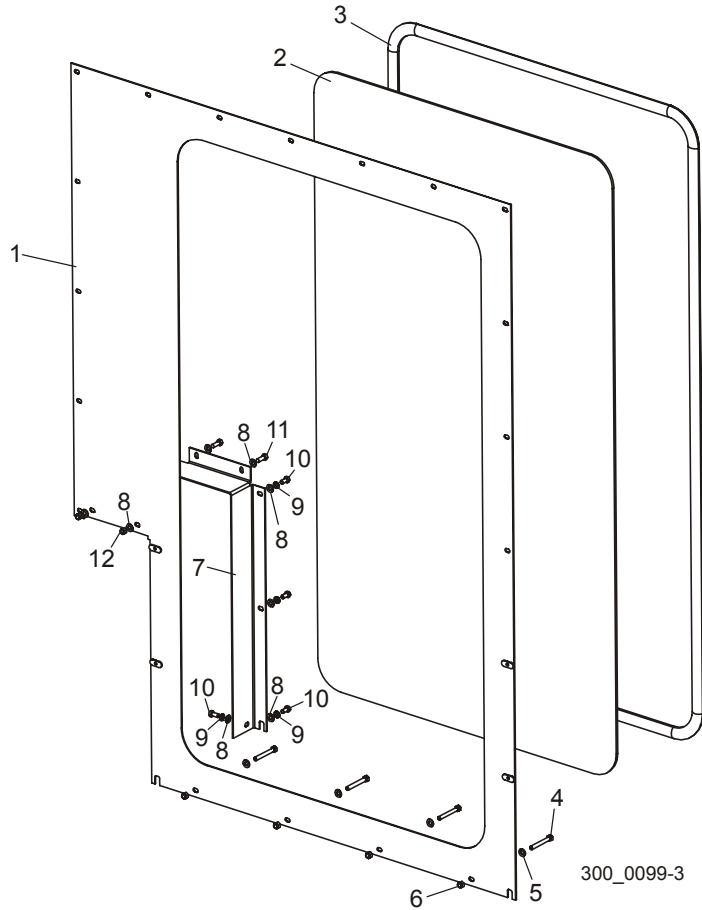

REF	DESCRIPTION (◆ Indicates Parts Available In Assemblies Only)	PART #	QTY.
	PANEL ASSEMBLY, CAB2 FRONT	036605	1
1	Panel Weldment, Cab2 Front	036604	1
2	Window, Cab Front	042631	1
3	Seal, Cab Front Window	042630	1
4	Bolt, 3/8-16 x 3" Hex Head Full Thread	F05007-1	4
5	Washer, 3/8" SAE Flat	F05011-3	4
6	Nut, 3/8-16 Hex Nylon Lock	F05010-10	4
7	PANEL, RIGHT LOWER	036590	1
8	WASHER, 3/8" SAE FLAT	F05011-3	8
9	WASHER, 3/8" SPLIT LOCK	F05011-4	4
10	BOLT, 3/8-16 X 3/4" HEX HEAD	F05007-27	4
11	BOLT, 3/8-16 X 1" HEX HEAD	F05007-7	2
12	NUT, 3/8-16 HEX NYLON LOCK	F05010-10	2

11.5 Left Panel

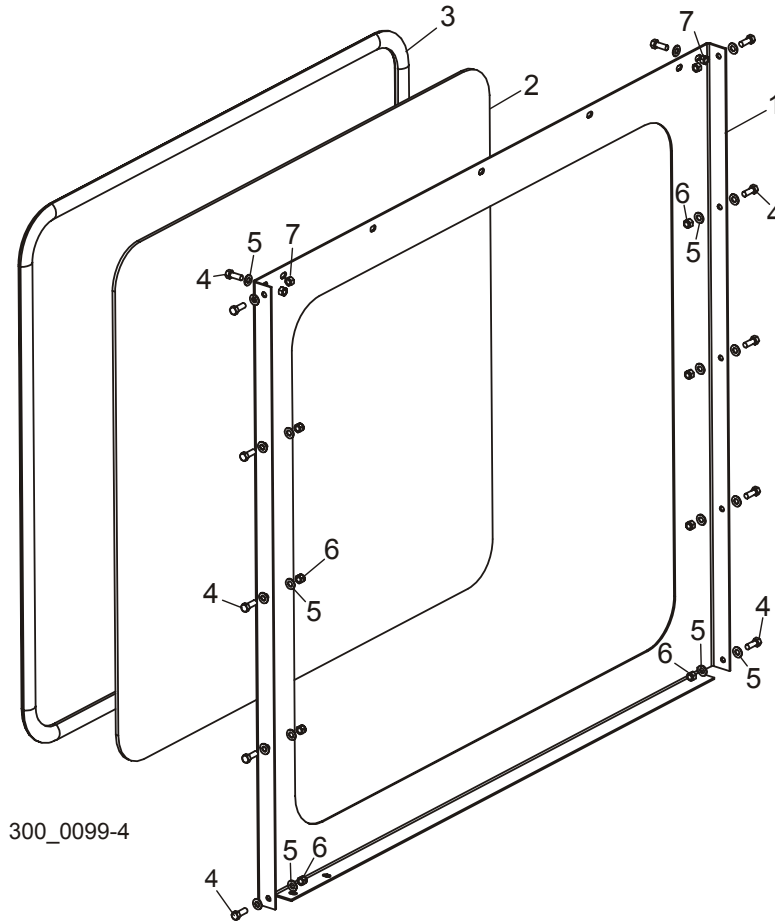

REF	DESCRIPTION (◆ Indicates Parts Available In Assemblies Only)	PART #	QTY.	
	PANEL ASSEMBLY, CAB2 LEFT	036588	1	
1	Panel, Cab2 Left	036587	1	
2	Window, Cab Left	042574	1	
3	Seal, Cab Side Window	042573	1	
4	BOLT, 3/8-16 X 1" HEX HEAD	F05007-7	12	
5	WASHER, 3/8" SAE FLAT	F05011-3	20	
6	NUT, 3/8-16 HEX NYLON LOCK	F05010-10	8	
7	NUT, 3/8-16 HEX LOCK	F05010-25	4	

11.6 Roof

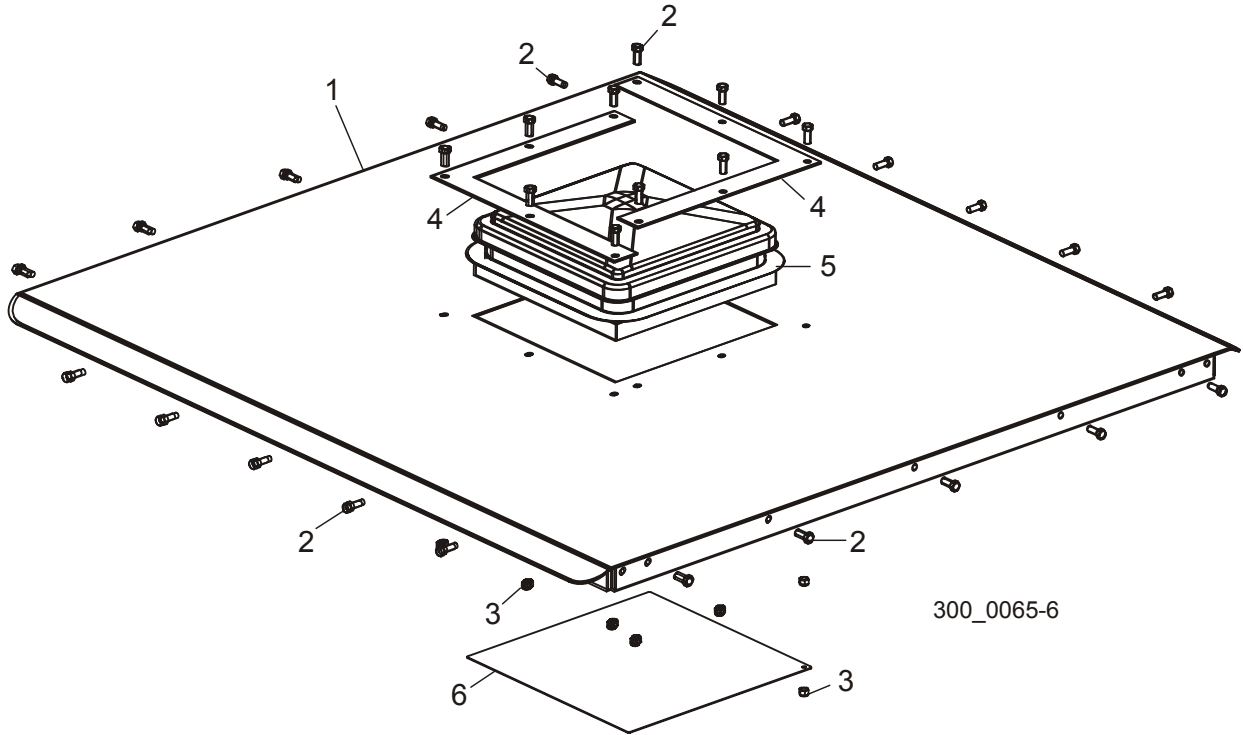

REF	DESCRIPTION (◆ Indicates Parts Available In Assemblies Only)	PART #	QTY.
	ROOF ASSEMBLY, CAB	042635	1
1	Roof Weldment, Cab	042623	1
2	Bolt, 3/8-16 x 1" Hex Head	F05007-7	30
3	Nut, 3/8-16 Hex Nylon Lock	F05010-10	30
4	Plate, Vent Mount	016866	2
5	Vent, Plastic Dome	016867	1
6	Plate, Roof Cover	042629	1

INDEX

B

- bed frame
 - cable carrier 7-4
 - wireway 7-2
- blade guide arm 2-9
- blade guides
 - drive side assembly 2-7
 - idle side (optional) 2-1
 - idle side assembly 2-3
- blade wheels
 - brake actuator & strap 3-7
 - drive side 3-3, 3-5
 - idle side w/brake 3-2

C

- cab option 11-1
 - front panel 11-7
 - left panel 11-8
 - rear panel 11-3
 - right panel 11-5
 - roof 11-9

D

- drive assembly
 - blade motor 3-9
- drive shaft 3-1

H

- hydraulics
 - log turner 8-5
 - pump & tank 8-19
 - valve 8-3

L

- lube system 9-1
- lube system (optional pressure) 9-3

M

- manuals 9-6

O

- operator station
 - air supply 10-5
 - frame/rails/ladder 10-1
 - seat/joystick controls 10-3

P

- parts list
 - how to use 1-1
- power feed
 - drive 6-5
 - feed chain/stops 6-7
 - lower track rollers 6-3
 - lower wireway 6-8
 - upper track rollers 6-1

S

- saw head
 - blow-off assembly 4-5
 - board return 4-1
 - board return guide 4-2
 - covers 4-3
 - decals 4-8, 4-10
 - head/air box 4-11
 - laser assembly 4-6

T

tools 9-5

U

up/down

ballscrew mount (middle) 5-6

ballscrew mount (top) 5-8

bearing rails 5-3

drive 5-4

head stop 5-9

mast pads/rollers 5-1

transducer 5-9