

user manual

Instrukcja obsługi | Руководство пользователя
Manuel de l'Utilisateur | Betriebsanweisung
Bruksanvisning | Manual del Usuario
Betjeningsvejledning | Gebruikershandleiding
Käyttöohjeet | Manual de utilizare | Bruksanvisning
Manuale d'uso | Příručka uživatele

Zachować do przyszłego użytku
Сохраните для последующего использования
A conserver pour une utilisation future
Für zukünftige Benutzung aufbewahren
Behold for senere bruk
Säilytä nämä käyttöohjeet tulevaa tarvetta marten
Opbevar manualen til fremtidig brug
Bewaren voor gebruik in de toekomst
Conservare il presente manuale a l'uso futuro
Păstrați acest manual pentru utilizare viitoare
Conservar para futuras consultas
Uchovajte pro další použití

INDUSTRIAL PRODUCTS

Safety, Setup & Operation Manual

LT300

rev. B1.02



Safety is our #1 concern! Read and understand all safety information and instructions before operating, setting up or maintaining this machine.

February 2002

Form #988

Table of Contents

Section-Page

| | | |
|--------------------------|--|------------|
| ABOUT THIS MANUAL | | VI |
| SECTION 1 | SAFETY | 1-1 |
| 1.1 | Safety Symbols..... | 1-1 |
| 1.2 | Safety Instructions..... | 1-2 |
| SECTION 2 | SERVICING THE SAWMILL | 2-1 |
| 2.1 | If You Need To Order Parts..... | 2-1 |
| 2.2 | Customer and Sawmill Identification..... | 2-2 |
| 2.3 | If You Need Service..... | 2-4 |
| SECTION 3 | SETUP | 3-1 |
| 3.1 | Site Preparation..... | 3-1 |
| 3.2 | Operator Station Installation..... | 3-3 |
| 3.3 | Lube Installation..... | 3-4 |
| | 3.3.1 Standard Lube System..... | 3-4 |
| | 3.3.2 Optional Pressure Lube System..... | 3-7 |
| 3.4 | Electrical Installation..... | 3-9 |
| | 3.4.1 Power Feed & Up/Down Cables..... | 3-14 |
| | 3.4.2 Up/Down Brake Cable..... | 3-15 |
| | 3.4.3 Blade Motor Cable..... | 3-16 |
| | 3.4.4 Head Box Cable..... | 3-17 |
| | 3.4.5 Transducer Cable..... | 3-19 |
| | 3.4.6 Lubemizer Cable..... | 3-20 |
| | 3.4.7 Debarker Option Foot Switch..... | 3-21 |
| | 3.4.8 Debarker Option Motor..... | 3-22 |
| 3.5 | Hydraulic Installation..... | 3-24 |
| 3.6 | Sawmill Installation..... | 3-26 |
| 3.7 | Air Installation..... | 3-27 |
| 3.8 | Sawmill Installation Setup..... | 3-28 |
| | 3.8.1 Level Sub-Frame..... | 3-28 |
| | 3.8.2 Level Saw Head..... | 3-31 |
| | 3.8.3 Level Bed Rails..... | 3-35 |
| | 3.8.4 Level Blade Guide Arm..... | 3-36 |
| | 3.8.5 Side Support Setup..... | 3-39 |
| 3.9 | Initial Control Programming..... | 3-40 |
| | 3.9.1 Blade Height Calibration..... | 3-40 |
| | 3.9.2 Upper Saw Head Travel Limit..... | 3-42 |
| | 3.9.3 Power Feed Calibration..... | 3-42 |
| | 3.9.4 Kerf..... | 3-42 |

Table of Contents

Section-Page

| | | |
|------------------|--|-------------|
| SECTION 4 | OPERATION | 4-1 |
| 4.1 | Control Overview | 4-1 |
| 4.2 | Distribution Box Overview | 4-3 |
| 4.3 | Joystick Control Overview | 4-4 |
| 4.4 | Cruise Control | 4-11 |
| 4.5 | Programming The Control..... | 4-12 |
| | <i>4.5.1 Board Thickness</i> | <i>4-12</i> |
| | <i>4.5.2 Cant Size</i> | <i>4-13</i> |
| | <i>4.5.3 Max HP, Max PF & Lube.....</i> | <i>4-14</i> |
| | <i>4.5.4 Calibration.....</i> | <i>4-15</i> |
| | <i>4.5.5 Upper Saw Head Travel Limit.....</i> | <i>4-15</i> |
| | <i>4.5.6 Other Settings</i> | <i>4-15</i> |
| 4.6 | Starting The Machine | 4-16 |
| 4.7 | Installing A Blade..... | 4-17 |
| 4.8 | Loading, Turning And Clamping Logs | 4-20 |
| 4.9 | Setworks Overview | 4-26 |
| | <i>4.9.1 Temporary Reference Mode</i> | <i>4-27</i> |
| | <i>4.9.2 Pattern Mode</i> | <i>4-33</i> |
| 4.10 | Sawing Logs | 4-38 |
| | <i>4.10.1 Prepare the LT300 for loading a log.....</i> | <i>4-38</i> |
| | <i>4.10.2 Load the log.....</i> | <i>4-38</i> |
| | <i>4.10.3 Turn the log</i> | <i>4-39</i> |
| | <i>4.10.4 Clamp the log.....</i> | <i>4-39</i> |
| | <i>4.10.5 Level the log.....</i> | <i>4-39</i> |
| | <i>4.10.6 Saw the log.....</i> | <i>4-40</i> |
| SECTION 5 | MAINTENANCE | 5-1 |
| 5.1 | Blade Guides (Standard Block/Roller Guides)..... | 5-1 |
| 5.2 | Blade Guides (Optional Block Guides)..... | 5-2 |
| 5.3 | Sawdust Removal | 5-5 |
| 5.4 | Track Rails & Scrapers..... | 5-6 |
| 5.5 | Miscellaneous | 5-8 |

Table of Contents

Section-Page

| | | | |
|--|--|------|-------------|
| 5.6 | Proximity Sensors..... | 5-9 | |
| | 5.6.2 Feed Slow-down/Stop Sensors..... | 5-10 | |
| | 5.6.3 Broken Blade Sensor | 5-11 | |
| | 5.6.4 Up/Down Ball Screw Sensor | 5-12 | |
| 5.7 | Hydraulic System Maintenance..... | 5-13 | |
| 5.8 | Blade Wheel Bearings & Scrapers | 5-14 | |
| 5.9 | Up/Down System..... | 5-15 | |
| 5.10 | Power Feed..... | 5-17 | |
| 5.11 | Drive Belt Tension | 5-20 | |
| 5.12 | Turner Chain Tension..... | 5-22 | |
| SECTION 6 TROUBLESHOOTING | | | 6-1 |
| 6.1 | Error Codes..... | 6-1 | |
| 6.2 | Blade Guides | 6-4 | |
| SECTION 7 ALIGNMENT | | | 7-1 |
| 7.1 | Bed Frame | 7-1 | |
| | 7.1.1 Level Bed Frame In Length Direction..... | 7-1 | |
| | 7.1.2 Level Bed Frame In Width Direction | 7-2 | |
| | 7.1.3 Level Saw Head | 7-3 | |
| | 7.1.4 Level Bed Rails | 7-5 | |
| | 7.1.5 Align Side Supports | 7-6 | |
| 7.2 | Blade Guides (Standard Block/Roller Guides)..... | 7-7 | |
| | 7.2.1 Blade Guide Adjustment Overview..... | 7-7 | |
| | 7.2.2 Preparing For Blade Guide Alignment | 7-11 | |
| | 7.2.3 Blade Wheel Vertical Alignment..... | 7-12 | |
| | 7.2.4 Blade Guide Arm Alignment..... | 7-14 | |
| | 7.2.5 Blade Guide Alignment..... | 7-16 | |
| 7.3 | Blade Guides (Optional Block Guides)..... | 7-26 | |
| | 7.3.1 Blade Guide Adjustment Overview..... | 7-26 | |
| | 7.3.2 Preparing For Blade Guide Alignment | 7-30 | |
| | 7.3.3 Blade Wheel Vertical Alignment..... | 7-33 | |
| | 7.3.4 Blade Guide Arm Alignment..... | 7-35 | |
| | 7.3.5 Blade Guide Alignment..... | 7-37 | |
| SECTION 8 SPECIFICATION | | | 7-41 |
| 8.1 | Overall Dimensions | 7-41 | |
| 8.2 | Motor Specifications | 7-41 | |
| 8.3 | Blade Specifications | 7-42 | |
| 8.4 | Dust Extractor Specifications | 7-42 | |
| SECTION 9 HYDRAULIC & AIR INFORMATION | | | 8-1 |
| 9.1 | Hydraulic Schematic | 8-1 | |
| 9.2 | Hydraulic Hoses | 8-2 | |

Table of Contents

Section-Page

| | | |
|-----|-----------------------------|-----|
| 9.3 | Hydraulic Components | 8-3 |
| B.1 | Air Schematic | 1-1 |
| B.2 | Head/Air Box Plumbing | 1-2 |

INDEX

I

ABOUT THIS MANUAL

This manual is to replace or to be used with all previous information received on the Wood-Mizer® sawmill. All future mailings will be an addition to or a revision of individual sections of this manual as we obtain new information.

The information and instructions given in this manual do not amend or extend the limited warranties for the equipment given at the time of purchase.

For general information regarding Wood-Mizer and our “Forest to Final Form” products, please refer to the All Products Catalog in your support package.

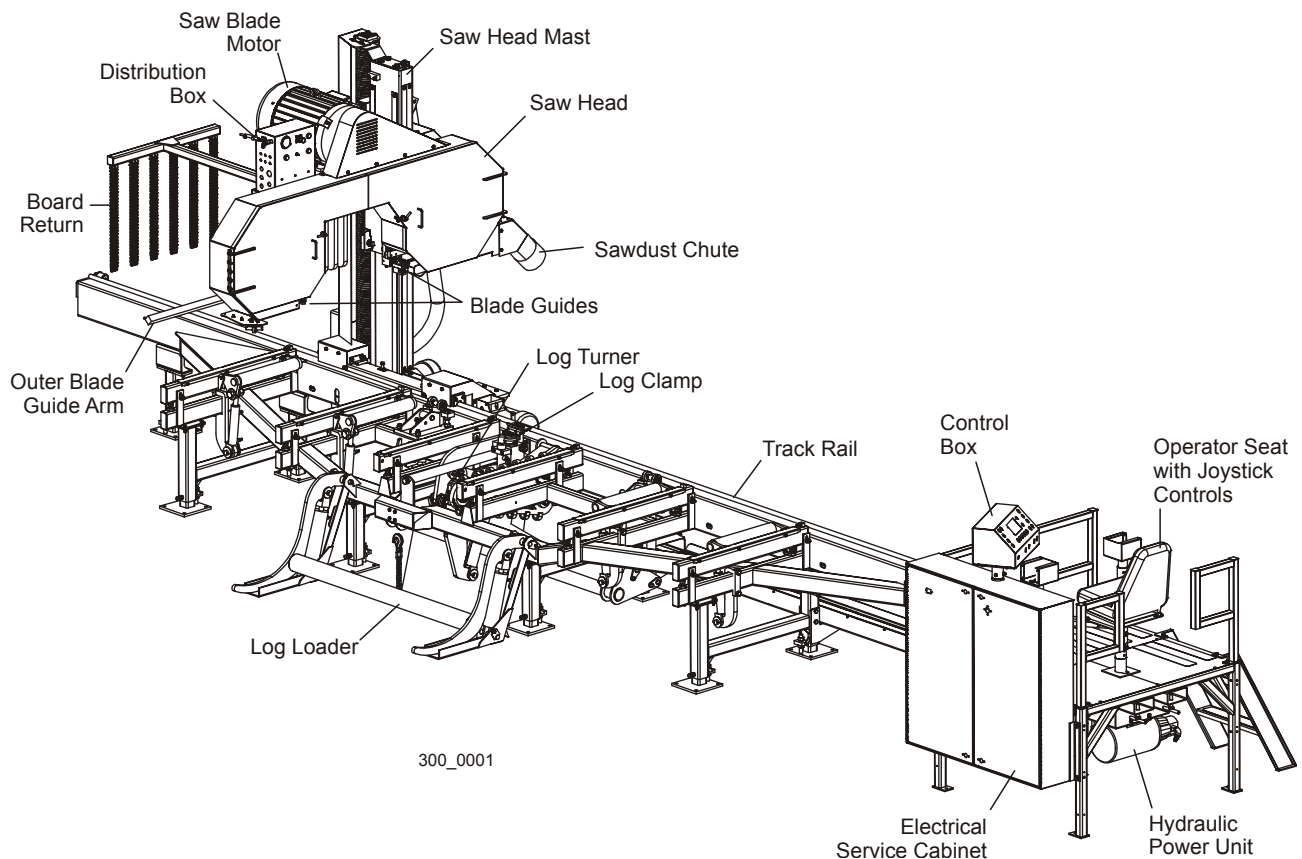

MILL COMPONENTS

*Wood-Mizer® is a registered trademark of Wood-Mizer Products, Inc.
Sawmill U.S. Patent Nos.: 4,559,858, 4,878,411 & 4,930,386
Brevet au Canada Nos.: 1,200,180 & 1,211,684

SECTION 1 SAFETY

1.1 Safety Symbols

The following symbols and signal words call your attention to instructions concerning your personal safety. Be sure to observe and follow these instructions.



DANGER! indicates an imminently hazardous situation which, if not avoided, will result in death or serious injury.



WARNING! suggests a potentially hazardous situation which, if not avoided, could result in death or serious injury.



CAUTION! refers to potentially hazardous situations which, if not avoided, may result in minor or moderate injury or damage to equipment.



IMPORTANT! indicates vital information.

NOTE: gives helpful information.



Warning stripes are placed on areas where a single decal would be insufficient. To avoid serious injury, keep out of the path of any equipment marked with warning stripes.

1.2 Safety Instructions

NOTE: ONLY safety instructions regarding personal injury are listed in this section. Caution statements regarding only equipment damage appear where applicable throughout the manual.

OBSERVE SAFETY INSTRUCTIONS



IMPORTANT! Read the entire Operator's Manual before operating the sawmill. Take notice of all safety warnings throughout this manual and those posted on the machine. Keep this manual with this machine at all times, regardless of ownership.

Also read any additional manufacturer's manuals and observe any applicable safety instructions including dangers, warnings, and cautions.

Only persons who have read and understood the entire operator's manual should operate the sawmill. The sawmill is not intended for use by or around children.

IMPORTANT! It is always the owner's responsibility to comply with all applicable federal, state and local laws, rules and regulations regarding the ownership and operation of your Wood-Mizer sawmill. All Wood-Mizer mill owners are encouraged to become thoroughly familiar with these applicable laws and comply with them fully while using the mill.



WEAR SAFETY CLOTHING



WARNING! Secure all loose clothing and jewelry before operating the sawmill. Failure to do so may result in serious injury or death.

WARNING! Always wear gloves and eye protection when handling bandsaw blades. Changing blades is safest when done by one person! Keep all other persons away from area when coiling, carrying or changing a blade. Failure to do so may result in serious injury.

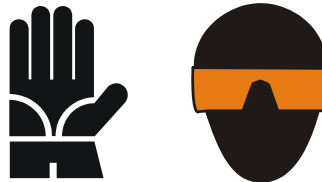

WARNING! Always wear eye, ear, respiration, and foot protection when operating or servicing the sawmill.



KEEP SAWMILL AND AREA AROUND SAWMILL CLEAN



DANGER! Maintain a clean and clear path for all necessary movement around the mill and lumber stacking areas. Failure to do so will result in serious injury.

HANDLE FUEL/LUBRICANTS SAFELY



WARNING! Use ONLY water or approved additives with the lube system. Never use flammable fuels or liquids. If these types of liquids are necessary to clean the blade, remove it and clean with a rag. Failure to do so may result in serious injury or death.

DISPOSE OF SAWING BY-PRODUCTS PROPERLY



IMPORTANT! Always properly dispose of all sawing by-products, including sawdust and other debris.

CAUTIONS FOR SAWMILL SETUP



WARNING! Securely fasten the feet of the sawmill to the floor before operating the sawmill. Failure to do so may result in serious injury or death.

CHECK SAWMILL/BLADES BEFORE OPERATION

 **DANGER!** Make sure all guards and covers are in place and secured before operating the sawmill. Failure to do so may result in serious injury.





 **WARNING!** Blade guide alignment is essential for optimal cutting performance, blade life and safety. Failure to check and maintain proper blade guide alignment will result in stress cracks forming in the blade. These cracks will lead to premature blade breakage. If the blade breaks during operation and the blade has multiple stress cracks, the blade could shatter into several pieces and escape from the protective guards of the sawmill. Small blade pieces projected into the area around the sawmill creates a safety hazard for the operator and any bystanders surrounding the mill.

WARNING! DO NOT use blades with stress cracks. Blades with stress cracks can shatter causing bodily injury and/or machine damage.

KEEP PERSONS AWAY

 **DANGER!** Keep all persons out of the path of moving equipment and logs when operating sawmill or loading and turning logs. Failure to do so will result in serious injury.

 **DANGER!** Always be sure all persons are out of the path of the blade before starting the motor. Stop the motor immediately when any person is nearby the sawmill. Failure to do so will result in serious injury.

 **DANGER!** To make access to the sawmill difficult for bystanders, mount a fence around the machine. The fence should be 1 to 1.2 m high and should be mounted at least 1.4 m away from the sawmill.

KEEP HANDS AWAY

DANGER! Always shut off the sawmill and wait until the blade wheels have come to a complete stop before changing the blade. Failure to do so will result in serious injury.

DANGER! Always keep hands away from moving bandsaw blade. Failure to do so will result in serious injury.

DANGER! Always be aware of and take proper protective measures against rotating shafts, pulleys, fans, etc. Always stay a safe distance from rotating members and make sure that loose clothing or long hair does not engage rotating members resulting in possible injury.

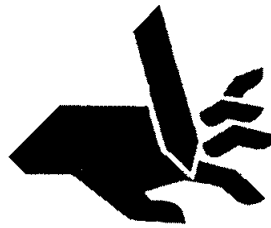

WARNING! Do not spin the blade wheels by hand. Spinning the blade wheels by hand may result in serious injury.

WARNING! Always stop the blades when the sawmill is not cutting. Failure to do so may result in serious injury.

WARNING! Do not for any reason adjust the drive belts with the motor running. Doing so may result in serious injury.

WARNING! Always keep clear of exiting sawdust. Keep hands, feet and any other objects away from the sawdust chute when operating sawmill. Failure to do so may result in serious injury.

USE PROPER PROCEDURE WHEN CONDUCTING ELECTRICAL SAFETY CHECKS AND MAINTENANCE



DANGER! Make sure all electrical installation, service and/or maintenance work is performed by a qualified electrician and is in accordance with applicable electrical codes.

DANGER! Hazardous voltage inside the electric sawmill disconnect box, starter box, and at the motor can cause shock, burns, or death. Disconnect and lock out power supply before servicing! Keep all electrical component covers closed and securely fastened during mill operation.

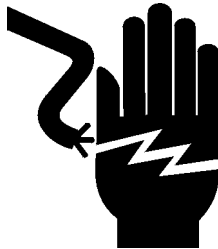

WARNING! Consider all electrical circuits energized and dangerous.

WARNING! Never assume or take the word of another person that the power is off; check it out and lock it out.

WARNING! Do not wear rings, watches, or other jewelry while working around an open electrical circuit.

WARNING! Before performing service near moving parts such as blades, pulleys, motors, belts and chains, first turn the key switch to the OFF (#0) position and remove the key. If the key is turned on and moving parts activated, serious injury may result.

WARNING! Remove the blade before performing any service to the engine or sawmill. Failure to do so may result in serious injury.

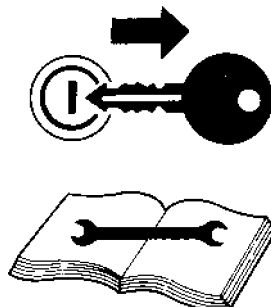

KEEP SAFETY LABELS IN GOOD CONDITION



IMPORTANT! Always be sure that all safety decals are clean and readable. Replace all damaged safety decals to prevent personal injury or damage to the equipment. Contact your local distributor, or call your Customer Service Representative to order more decals.



IMPORTANT! If replacing a component which has a safety decal affixed to it, make sure the new component also has the safety decal affixed.

USE CAUTION WHEN WORKING WITH HEAVY LOGS



WARNING! Always make sure log is clamped securely before sawing. Failure to do so may result in serious injury or death.

AUTOMATIC BOARD RETURN SAFETY



DANGER! Keep all persons out of the path of returning boards. Failure to do so will result in serious injury.

POWER FEED AND UP/DOWN SYSTEM SAFETY





DANGER! If leaving the blade engaged for maximum production rates, make sure the off-bearer stays out of the path of the blade. Failure to do so will result in serious injury or death.



CAUTION! Be sure the transducer sensor is adjusted properly before raising or lowering the saw head against the upper or lower travel limits. Failure to do so may result in damage to the machine.

See Table 1-1. Pictogram decals used to warn and inform the user about danger in the LT300.

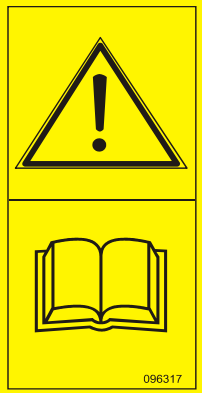
TABLE 1-1

| Decal View | W-M No. | Description |
|---|---------|---|
|  | 096317 | CAUTION! Read thoroughly the manual before operating the machine. Observe all safety instructions and rules when operating the sawmill. |
|  | 099220 | CAUTION! Close all guards and covers before starting the machine. |
|  | 099221 | CAUTION! Keep all persons a safe distance away from work area when operating the machine. |

1 Safety
Safety Instructions

TABLE 1-1

| | | |
|---|---------------|--|
|  <p>098176</p> | <p>098176</p> | <p>CAUTION! Keep away from debarker blade!</p> |
|  <p>096316</p> | <p>096316</p> | <p>CAUTION! Do not open or close the electric box when the switch is not in the "0" position.</p> |
|  <p>096319</p> | <p>096319</p> | <p>CAUTION! Disconnect power supply before opening the box.</p> |
|  <p>099222</p> | <p>099222</p> | <p>CAUTION! Sawdust outlet. Protect eyes!</p> |

TABLE 1-1





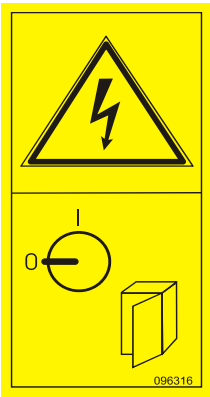
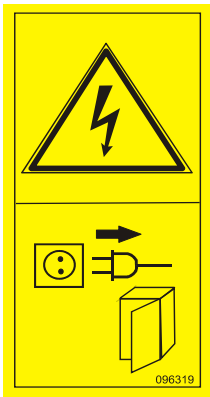
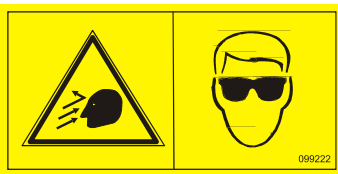

| | | |
|---|----------------|--|
|  | <p>101138</p> | <p>CAUTION! Do not operate up/down control while blade is moving. Always disengage blade before adjusting cutting head up or down.</p> |
|  | <p>096321</p> | <p>Blade movement direction</p> |
|  | <p>S12004G</p> | <p>CAUTION! Always wear safety goggles when operating the sawmill!</p> |
|  | <p>S12005G</p> | <p>CAUTION! Always wear protective ear muffs when operating the sawmill!</p> |
|  | <p>P11789</p> | <p>Aligning the blade on the wheels</p> |

TABLE 1-1

| | | |
|--|----------------|--|
|  | <p>P85070</p> | <p>CE safety certification</p> |
|  | <p>099401</p> | <p>Russian safety certification</p> |
|  | <p>S200971</p> | <p>1465 RPM - Motor rotation direction</p> |

SECTION 2 SERVICING THE SAWMILL

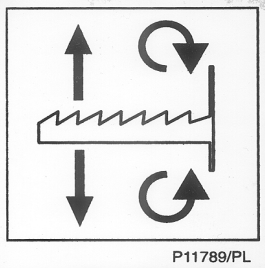
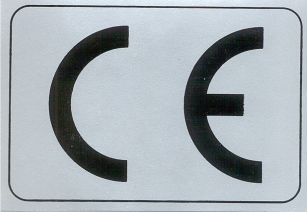
Wood-Mizer is committed to providing you with the latest technology, best quality and strongest customer service available on the market today. We continually evaluate our customers' needs to ensure we're meeting current wood-processing demands. Your comments and suggestions are welcome.

2.1 If You Need To Order Parts

From Europe call our European Headquarters and Manufacturing Facility in Kolo, ul Nagórna 114, Poland at **+48-63-2626000**

From the continental U.S., call our toll-free Parts hotline at **1-800-448-7881**.

Please have the vehicle identification number and your customer number ready when you call. Wood-Mizer will accept these methods of payment:

- Visa, Mastercard, or Discover
- COD
- Prepayment
- Net 15 (with approved credit)

Be aware that shipping and handling charges may apply. Handling charges are based on size and quantity of order. In most cases, items will ship on the day they are ordered. Second Day and Next Day shipping are available at additional cost.

If your sawmill was purchased outside of the United States, contact your distributor for replacement parts.

2 Servicing The Sawmill

Customer and Sawmill Identification

2.2 Customer and Sawmill Identification

Each Wood-Mizer LT300 sawmill is identified with a serial number, revision, and electrical information (see the figure below).

MFG BY/Fabrique par/Hergestellt von/Producent: Wood - Mizer Industries
sp. z o.o. ul. Nagórna 114, 62-600 Kolo, Poland

TYPE **LT300S** SERIAL No **10 2003 123 B1.02**

FLA OF LARGEST LOAD **39**

FLA **54** AIC **35kA** VOLTS **400** HZ **50** PH **3**

ELECTRICAL DIAGRAM No. **shlt300** PATENTS

IDENTIFICATION PLATE

The serial number contains the year and month of manufacture and a sequence number. The revision number helps identify the exact design of the equipment. See the table for a description of the serial and revision numbers as shown in the example above.

| Model No. | Date Of Manufacture | | Machine No. | Revision |
|-----------|---------------------|------|-------------|----------|
| | Month | Year | | |
| LT300S | 01 | 2003 | 123 | B1.02 |

SERIAL NUMBER DESCRIPTION

See the figure below for locations of the identification plates.

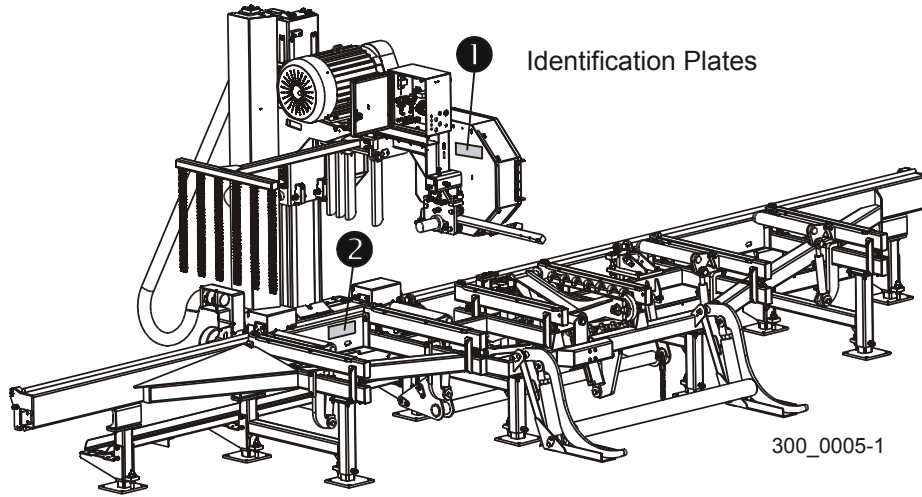

IDENTIFICATION PLATE LOCATIONS

2 Servicing The Sawmill

If You Need Service

2.3 If You Need Service

From Europe call our European Headquarters and Manufacturing Facility in Kolo, Nagórna 114, Poland at **+48-63-2626000** or **+48-3912-1319**. From the continental U.S., call us toll-free at **1-800-525-8100**. Ask to speak with a Customer Service Representative. Please have your vehicle identification number and your customer number ready when you call. The Service Representative can help you with questions about alignment of your mill, blade sharpening, or cutting a particular species of wood. He also can schedule you for a service call.

Office Hours: All times are Eastern Standard Time. Please remember that Indiana does not go on Daylight Savings Time in the summer.

| Country | Monday - Friday | Saturday | Sunday |
|----------------|------------------------|-----------------|---------------|
| U.S., Indiana | 8 a.m. to 5 p.m. | Closed | Closed |
| Poland | 8 a.m. to 4:30 p.m. | Closed | Closed |



IMPORTANT! Read the entire Operator's Manual before operating the sawmill. Take notice of all safety warnings throughout this manual and those posted on the machine. Keep this manual with this machine at all times, regardless of ownership.

SECTION 3 SETUP

3.1 Site Preparation



IMPORTANT! This information is provided so that you may have your site prepared for installation of your electric sawmill. In order to properly install your sawmill, you need to:

- 1. Prepare a firm, level area where the sawmill can be anchored.** There should be enough room around the sawmill for operators, sawdust removal, log loading and board removal. A cement pad with 1/2" diameter anchor bolts is recommended. The cement pad should be rated to support 6350 lbs./sq.ft. at each sawmill foot position.

The design of your site layout should be determined at the time of purchase. Wood-Mizer can provide detailed plans based on the requirements of your operation and the equipment you plan to install.

The sawmill is designed for indoor operation and should be fully protected from outdoor elements.

- 2. Have a qualified electrician install the power supply before receipt of your sawmill.** The power supply must meet the enclosed specifications concerning wire size, fused disconnect, and voltage. The electrical installation must also meet local codes.

See Table 3-1. Install a fused disconnect switch within sight of the machine. Typical minimum switch, fuse, and wire sizes are shown. All electrical installation must meet local electrical codes. Fuses are sized for short-circuit protection only. The motor is configured with internal thermostats for overload protection. If an overload condition does occur, the thermostats shut the motor down and the motor cannot be restarted until it cools to a safe operating temperature.

| 3-Phase Volts | Fuse Disconnect | Time Delay Fuse | Suggested Wire Size |
|------------------|--------------------|-----------------------|------------------------|
| 400 VAC | 100 Amps | 70 Amps | 16 mm ² |

TABLE 3-1

- 3. Have a qualified electrician present when the sawmill is to be installed.** All relevant motor specifications and wiring information is provided. When scheduling an electrician for the day of installation, please confirm that they have enough of the proper size cable (wiring), as shown above. Many electricians may not stock this cable, which could seriously delay installation and training.

See **Table 3-2**. This table lists the 30 horsepower motor specifications for your reference.

| 30HP Electric Motor Specifications | |
|---|-------------------|
| Horsepower | 30 (22kW) |
| RPM | 1465 |
| Volts | 400 |
| Amps | 39 |
| Ambient temperature | -15° to +40° C |
| Insulation Class | F |
| PH | 3 |
| Protection Degree | IP55 |
| Duty | Continuous |

TABLE 3-2

3.2 Operator Station Installation

The operator station is equipped with forklift pockets. Use a forklift rated for at least 8,000 lbs. Insert the forks into the pockets and secure with the pocket bolts.

Place the operator station in position. Anchoring the operator station is optional. If the operator station is to be anchored, it is recommended it be anchored after placement of the sawmill. This will allow for repositioning of the operator station relative to the sawmill for your desired operator position. Use 1/2" anchor bolts and nuts at each of the four foot locations to anchor the operator station to the floor if desired.

Install the ladder to the station deck using the provided 3/8-16 x 3" hex head bolts and nylon lock nuts.

See Figure 3-1.

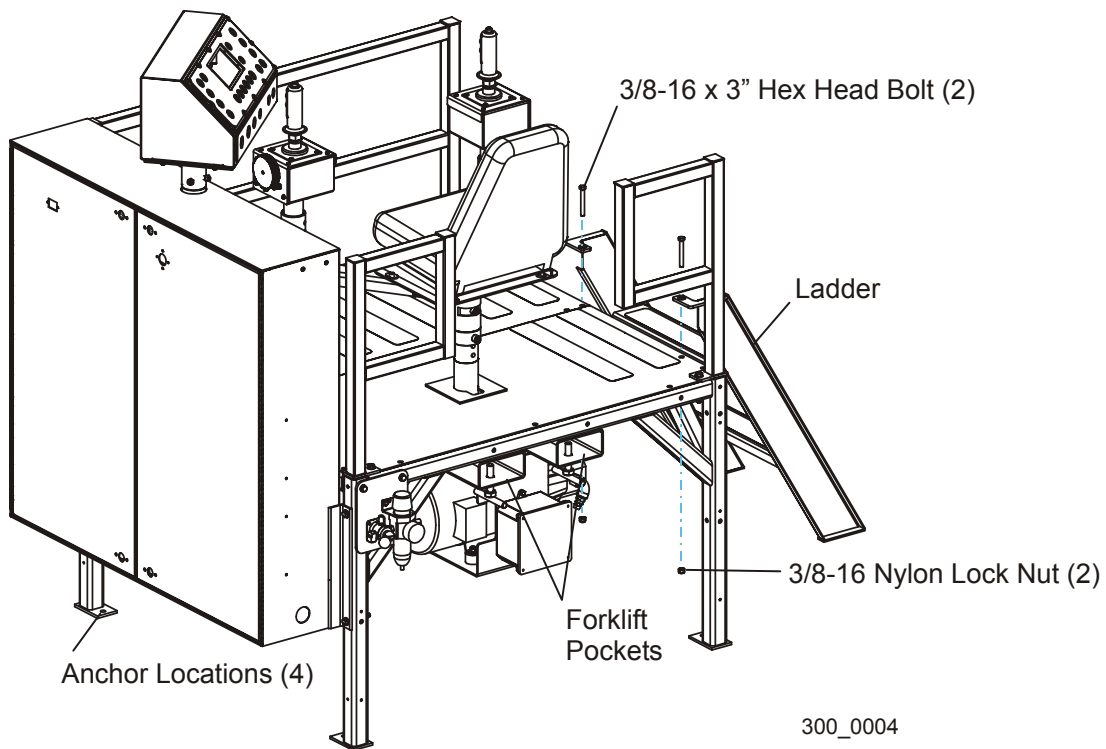

FIG. 3-1

3.3 Lube Installation

3.3.1 Standard Lube System

NOTE: If your LT300 is equipped with the optional Pressure Lube System, [See Section 3.3.2](#).

The LT300 blade lubrication system consists of a 55-gallon drum, filter, pump and all necessary fittings and hoses. A 5-gallon auxiliary tank is included that allows you to add vegetable oil to the lube water during operation. Using vegetable oil in the lube increases blade life and performance.

See Figure 3-2. The auxiliary tank can be mounted to the back of the operator's station using the hardware provided:

Without cab option: Use two 3" bolts, flat washers and lock nuts and one 1 1/2" bolt to mount the tank tray to the operator's station frame.

With cab option: Use two 1 1/2" bolts to mount the tank tray to the operator's station frame. Use two flat washers as spacers between the left bolt and cab wall.

The lube pump may be relocated to the auxiliary tank tray. Four 1" bolts, flat washers and lock nuts are provided for this purpose.

The lube system can also be positioned in a remote location up to 90' away from the saw-mill. If a remote position is desired, use your own hardware to mount the auxiliary tank on

a wall approximately 20" above the drum and mount the pump to the tray.

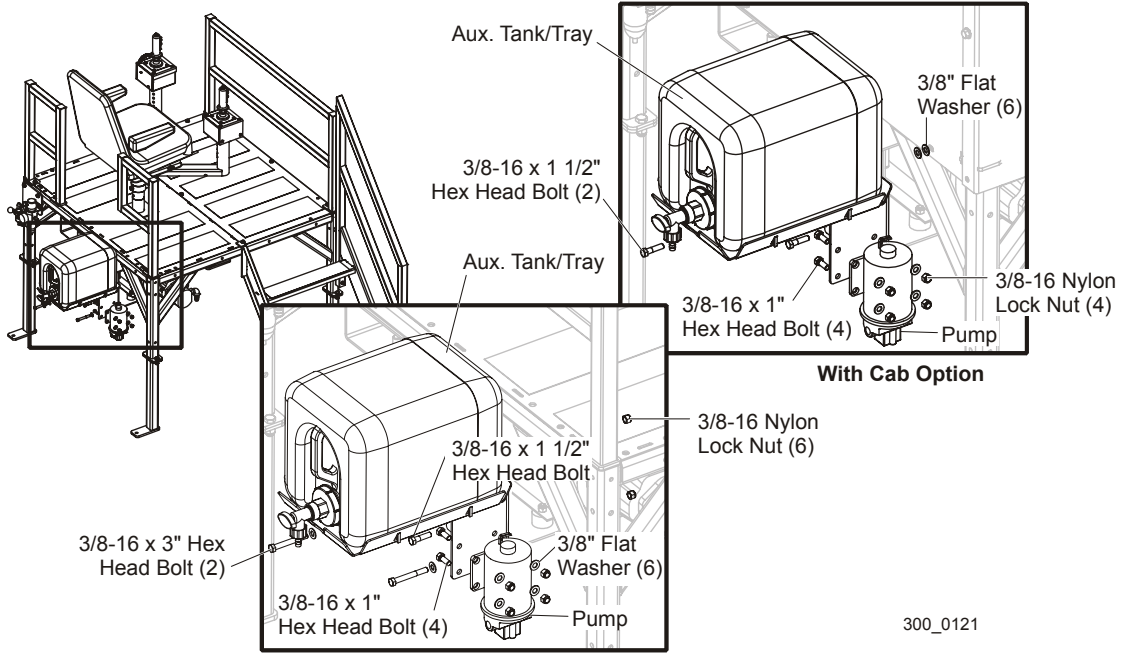

FIG. 3-2

3

Setup

Standard Lube System

See Figure 3-3. Connect the large hose from the filter to the large fitting on the pump and secure with the provided hose clamp. Connect the small hose from the valve to the small 'T' fitting on the pump. Push the fitting collar in, insert the hose and release the collar. Connect the electric cable to the pump harness, route it to the electrical cabinet at the operator station and connect the wires ([See Section 3.5.6](#)). Connect the lube hose from the sawmill blade guides to the 'T' fitting on the pump.

Remove the fill cap from the drum and fill with water. Replace the fill cap.

Fill the auxiliary tank with any inexpensive cooking/vegetable oil. Wood-Mizer has found soybean oil to be inexpensive and performs well. In cold temperatures, vegetable oil tends to gel. If temperatures are cold enough to cause the oil to thicken, dilute the oil at a ratio of 50:1 with a pour point depressant such as EverFlow #107671A.

Open the shut-off valve on the auxiliary tank all the way. Open the oil flow control valve 1/4-turn. Use the lube control valve to control volume of water/oil solution to the blade guides. Experiment with different valve settings to achieve the best performance depending on species being cut. Oil usage should be approximately 2-4 qts. per 8 hour shift.

When finished sawing, close the shut-off valve on the auxiliary tank and run the blade for 30 seconds with water only to flush the system and prevent oil from gumming the nozzles when not operating.

Immediately fix any leaks and wipe up any oil spills. Oil will collect sawdust and will be difficult to cleanup after it gels.

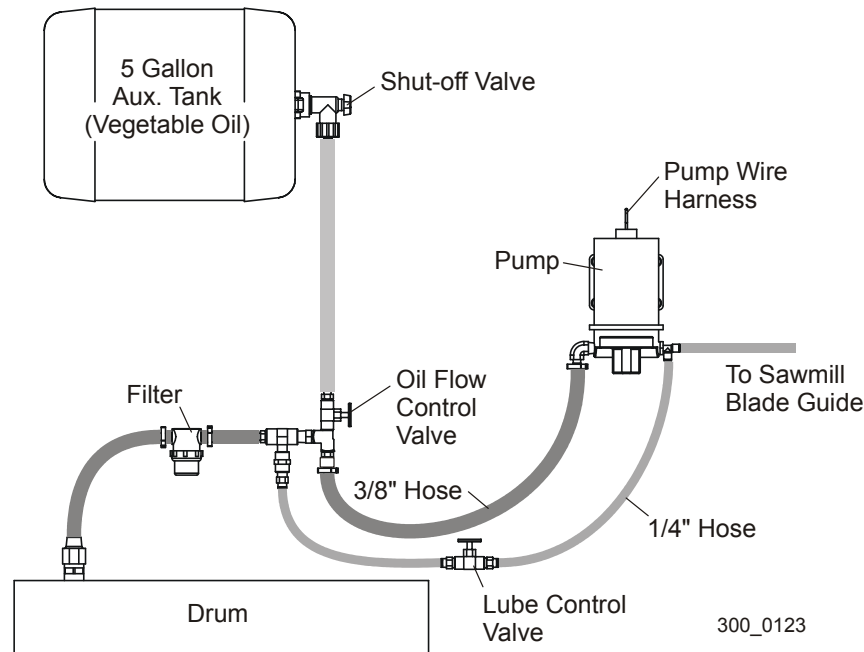

FIG. 3-3

3.3.2 Optional Pressure Lube System

NOTE: If your LT300 is equipped with the standard Lube System, [See Section 3.3.1](#).

The optional pressure lube system consists of a unit mounted at the back of the operator station where a water supply line can be connected. A 2-gallon reservoir is included that allows you to add vegetable oil to the lube water during operation. Using vegetable oil in the lube increases blade life and performance.

See Figure 3-4. Connect a water supply hose to the water line fitting. Connect the 1/4" hose from the sawmill blade guide to the 1/4" 'T' fitting below the solenoid. Connect the 1/2" hose from the blow-off assembly to the 1/2" 'T' fitting at the top of the reservoir. Route the cable from the solenoid valve to the electrical cabinet at the operator station and connect the wires ([See Section 3.5.6](#)).

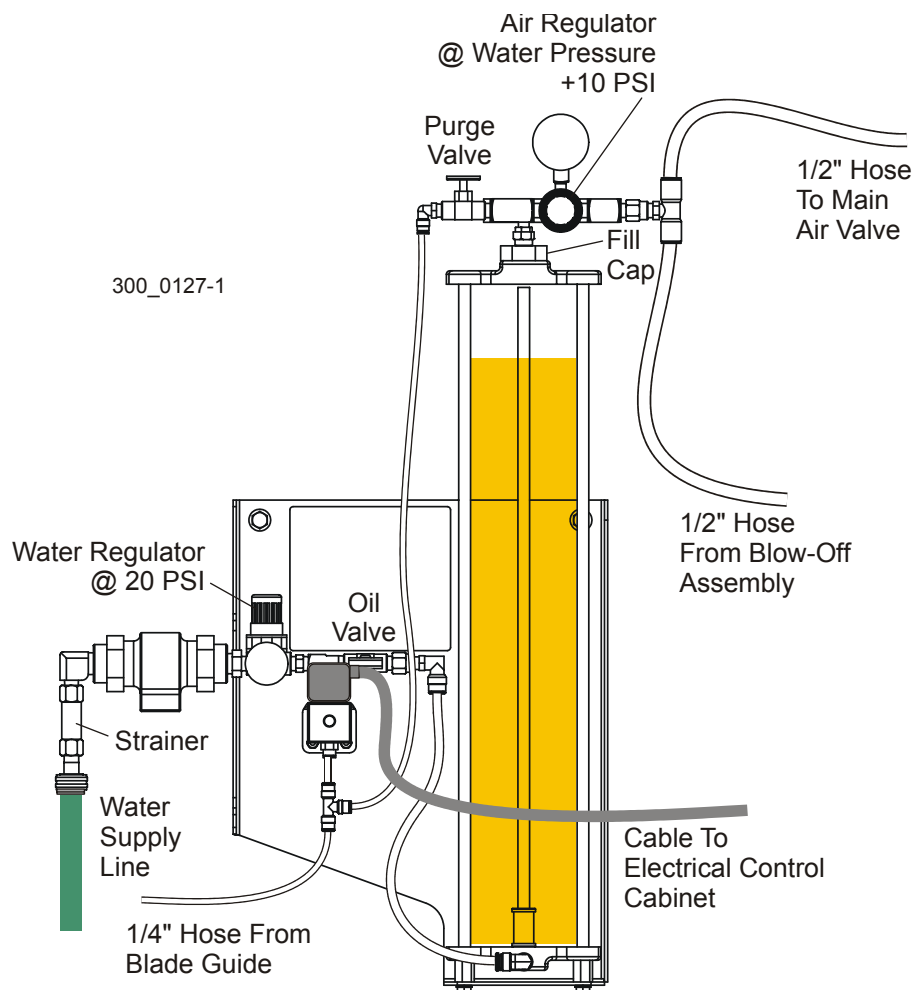

FIG. 3-4

3

Setup

Optional Pressure Lube System

Be sure the main air valve is closed and open the purge valve to relieve any pressure in the tank. Close the purge valve and open the fill cap. Fill the reservoir tank with any inexpensive cooking/vegetable oil. Wood-Mizer has found soybean oil to be inexpensive and performs well. In cold temperatures, vegetable oil tends to gel. If temperatures are cold enough to cause the oil to thicken, dilute the oil at a ratio of 50:1 with a pour point depressant such as EverFlow #107671A.

Turn on the water and air supply. The water regulator valve should be set at 20 PSI and can be adjusted up to 35 PSI if necessary due to water pressure. Set the air regulator valve 10 PSI higher than the water valve. Be sure the purge valve is closed during operation. Open the oil valve 1/4" turn.

Experiment with different valve settings to achieve the best performance depending on species being cut. Oil usage should be approximately 2-4 qts. per 8 hour shift.

When finished sawing, close the oil valve and open the purge valve. Run the blade for 30 seconds with water only to flush the system and prevent oil from gumming the nozzles when not operating.

Immediately fix any leaks and wipe up any oil spills. Oil will collect sawdust and will be difficult to cleanup after it gels.

Periodically clean the water strainer. With the water supply off, unscrew the strainer housing, clean the strainer and reassemble.

3.4 Electrical Installation

⚠ DANGER! Make sure all electrical installation, service and/or maintenance work is performed by a qualified electrician and is in accordance with applicable electrical codes.

See **Figure 3-5**. Route the incoming power supply from the disconnect switch to the electrical cabinet. One recommended method is to drop conduit from the ceiling down to the hole in the right side of the cabinet, near the bottom. Install an elbow connector to secure the conduit to the cabinet. Connect the ground wire to the ground bar at the bottom of the cabinet. Remove the wireway covers and route the three power lines through the wireways to the disconnect block at the top of the cabinet.

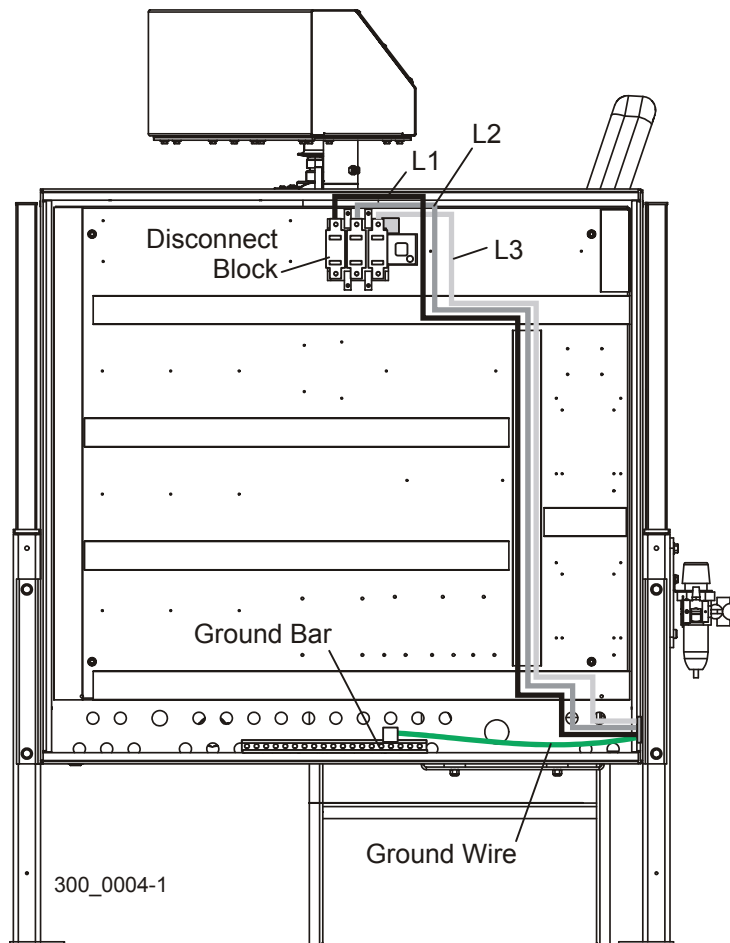

FIG. 3-5

See **Figure 3-6**. Several cables connect the sawmill controls to the components in the electrical cabinet. Route the cables under the operator station and tie wrap to the bracket

3 Setup

Electrical Installation

as shown.

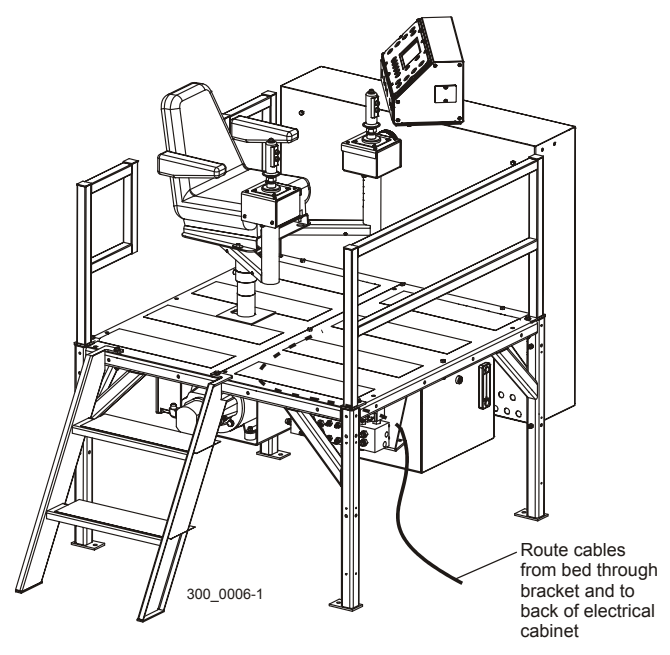

FIG. 3-6

See Table 3-3. Locate and identify each cable as shown in the table below.

| Cable | Function | Box Entry Location See fig. 3-17 Rev. A6.00+ | Wire Terminal Number | Termination Location (Component ID.Terminal ID) |
|-------|--|---|----------------------|--|
| 1 | Power Feed See fig. 3-19 | P/F | 500 | U1.T1 |
| | | | 501 | U1.T2 |
| | | | 502 | U1.T3 |
| | | | Ground | U1 Ground |
| 2 | Up/Down See fig. 3-19 | U/D | 503 | U2.T1 |
| | | | 504 | U2.T2 |
| | | | 505 | U2.T3 |
| | | | Ground | U2 Ground |
| 3 | Up/Down Brake See fig. 3-20 | Brk | 506 | K5.T1 |
| | | | 334 | K4.T2 |
| 4 | Blade Motor See fig. 3-21 | 25hp Mtr | K35.T1 | K35.T1 |
| | | | K35.T2 | K35.T2 |
| | | | K35.T3 | K35.T3 |
| | | | K33.T3 | K33.T3 |
| | | | K33.T1 | K33.T1 |
| | | | K33.T2 | K33.T2 |
| | | | Ground | Grounding Bar |
| 5 | Transducer See fig. 3-23 | Trans | 51 | 51 |
| | | | 53 | 53 |
| | | | 510 | 510 |
| | | | 511 | 511 |
| 7 | LubeMizer See fig. 3-24 | Lube | 70 | K6.2 |
| | | | 69 | 53 |

TABLE 3-3

3 Setup

Electrical Installation

| | | | | |
|-----|---|-------|--------|---------------|
| 8 | Head Box See fig. 3-22 | 20/16 | 26 | K31.2 |
| | | | 27 | K31.4 |
| | | | 53 | 53 |
| | | | 56 | 56 |
| | | | 132 | X5.A0 |
| | | | 133 | X5.A1 |
| | | | 134 | X5.A2 |
| | | | 135 | K10.11 |
| | | | 139 | X5.A7 |
| | | | 140 | X5.B0 |
| | | | 141 | X5.B1 |
| | | | 164 | KW.A1 |
| | | | 149 | X5.B7 |
| | | | 200 | X14.A0 |
| | | | 201 | X14.A1 |
| | | | 253 | K29.14 |
| 254 | K9.14 | | | |
| 9 | Debarker Option Foot Switch See fig. 3-15 | DBS | 56 | 56 |
| | | | 378 | X5.A5 |
| | | | Ground | Grounding Bar |
| 10 | Debarker Option Motor See fig. 3-16 | DBM | 21 | DB1.T1 |
| | | | 22 | DB1.T2 |
| | | | 23 | DB1.T3 |
| | | | 56 | K1.44 |
| | | | 379 | X5.A6 |
| | | | Ground | Grounding Bar |
| | | | 381 | DB1-14NO |

TABLE 3-3

See Figure 3-7. Insert each cable to the appropriate entry point in the electrical cabinet as show below. Secure each cable to the box with the provided cable connectors.

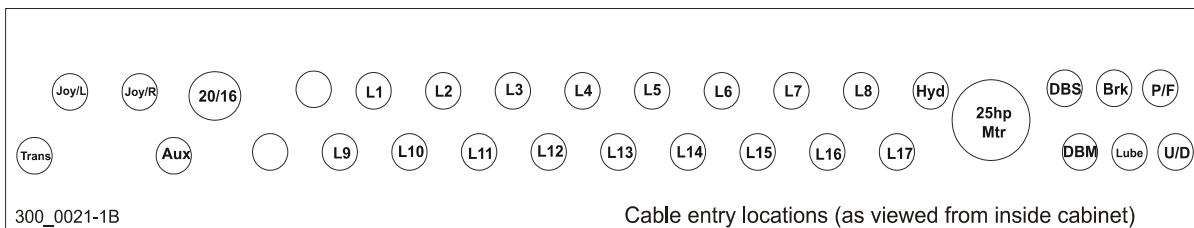

FIG. 3-7

See **Figure 3-8**. Route each cable to the appropriate components as described in the following instructions.

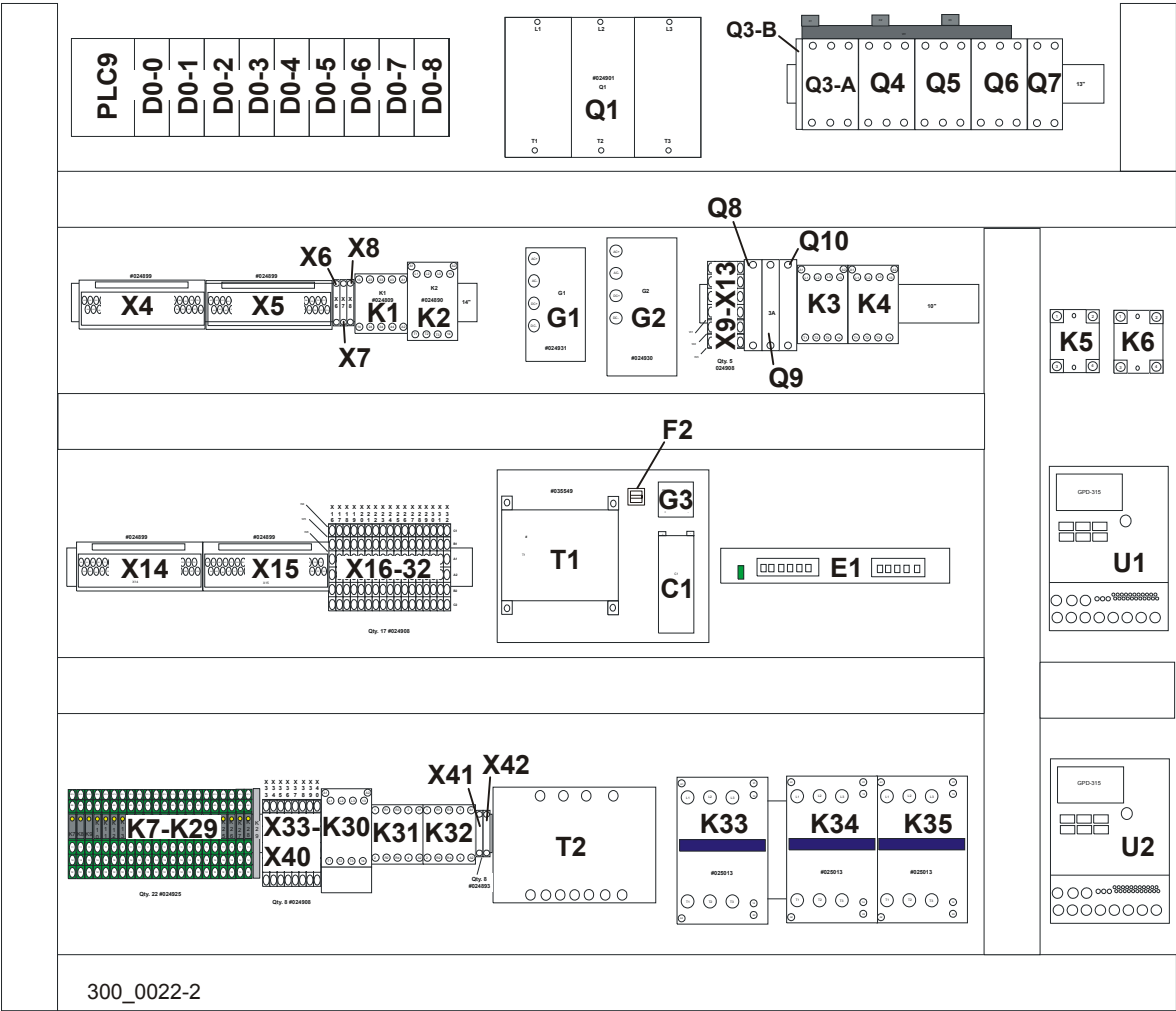

FIG. 3-8

3

Setup

Power Feed & Up/Down Cables

3.4.1 Power Feed & Up/Down Cables

See **Figure 3-9**. Route the power feed cable through the wireways to the clamp located under A/C drive labeled U1. Fold the metal shielding over the end of the cable and insert into the clamp. Tighten the clamp to secure the cable. Repeat for the up/down cable to the A/C drive labeled U2.

Connect the power feed cable wires to A/C drive labeled U1: Connect wire #500 to terminal #T1, wire #501 to terminal #T2, and wire #502 to terminal #T3. Connect the green ground wire to the ground terminal.

Connect the up/down cable wires to the A/C drive labeled U2: Connect wire #503 to terminal #T1, wire #504 to terminal #T2 and wire #505 to terminal T3. Connect the green ground wire to the ground terminal.

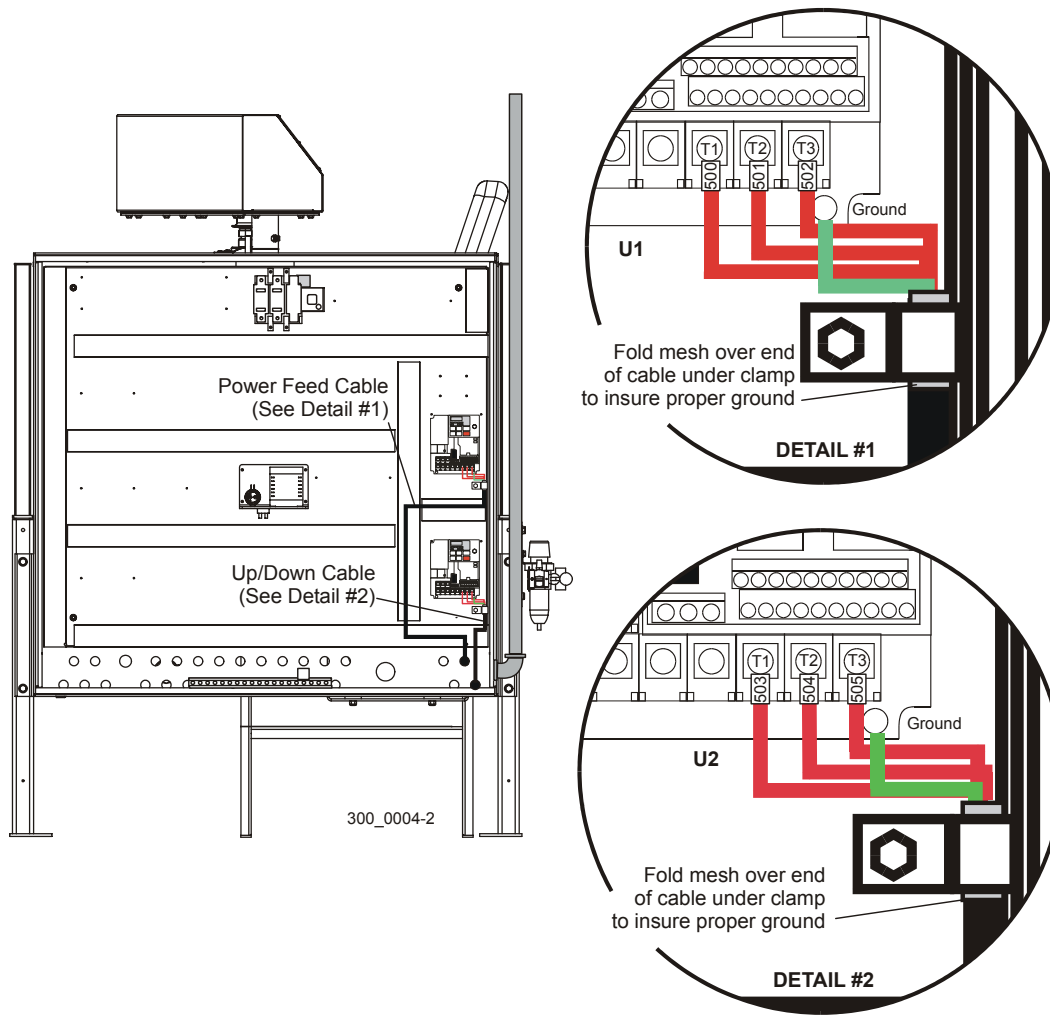

FIG. 3-9

3.4.2 Up/Down Brake Cable

See **Figure 3-10**. Route the up/down brake cable through the wireways to the contactor and relay as shown. Connect wire #334 to terminal #T2 of the contactor labeled K4. Connect wire #506 to terminal #2 of the relay labeled K5.

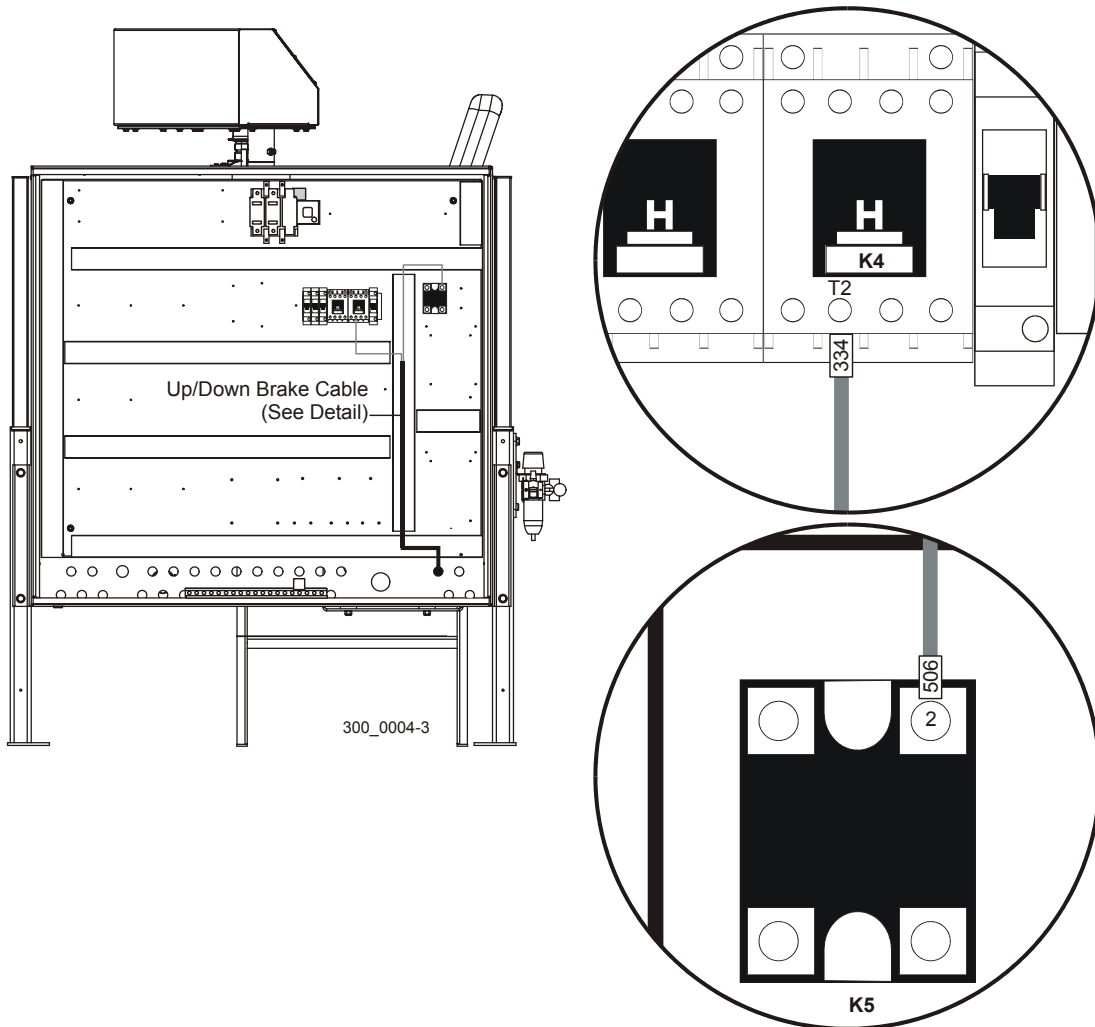

FIG. 3-10

3.4.3 Blade Motor Cable

See **Figure 3-11**. Route the motor cable wires with terminals labeled #1, #2 & #3 to the contactor labeled K35. Route wires with terminals labeled #10, 11 & 12 to the contactor labeled K33. Route the green/yellow striped wire to the grounding bar. Route wires with terminals labeled #53 & #146 to the terminal blocks labeled X41 and X42.

At contactor K35, connect wire #1 to terminal T1, wire #2 to terminal T2, and wire #3 to terminal T3. At contactor K33, connect wire #10 to terminal T3, wire #11 to terminal T1, and wire #12 to terminal T2. Connect wire #53 to the bottom terminal of block X41. Connect wire #146 to the bottom terminal of block X42. Connect the ground wire to one of the ports in the grounding bar and secure with a screw.

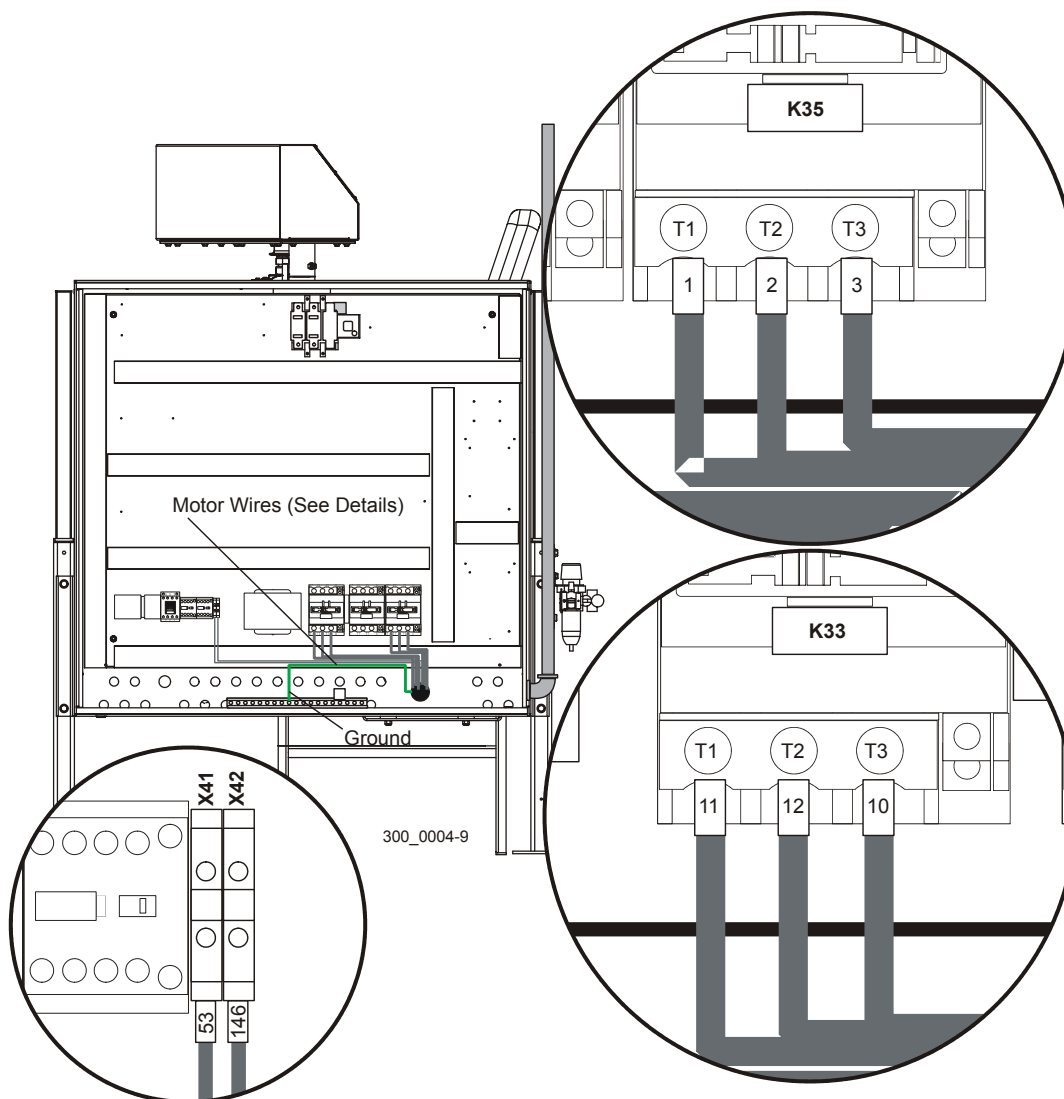

FIG. 3-11

3.4.4 Head Box Cable

See Figure 3-12. Route the head box cable wires through the wireways to the appropriate components. Route wires with terminals labeled #132, #133, #134, #139, #140, #141 & #149 to the terminal module labeled X5. Route wires with terminals labeled #53 and #56 to the terminal blocks labeled X16-X32. Route the wires with terminals labeled #164, #165 & #166 to the wireway located above the bank of contactors labeled X16-32. These wires are not used. Route the wires with terminals labeled #200 and #201 to the terminal module labeled X14. Route the wire with terminal labeled #68 to the terminal block labeled X40. Route the wires with terminals labeled #135, #253, #254 and #278 to the components labeled K7-K30. Route the wire with terminal labeled #26 and #27 to the relay labeled K31.

At terminal module X5, connect wire #132 to terminal #A0, wire #133 to terminal #A1, wire #134 to terminal #A2, wire #139 to terminal #A7, wire #140 to terminal #B0, wire #141 to terminal #B1 and wire #149 to terminal #B7.

At block X19, connect wire #56 to terminal #B2. At block X26, connect wire #53 to terminal #A2. At relay K29, connect wire #253 to terminal #14.

At connector module X14, connect wire #200 to terminal #A0 and wire #201 to terminal #A1.

At relay K9, connect wire #254 to terminal #14. At relay K10, connect wire #135 to terminal #14. At relay K32, connect wire #26 to terminal #2 and wire #27 to terminal #3 (leave existing wires connected).

3 Setup Head Box Cable

Debarker Option Only: Route wire #4 to terminal block X29 and connect to terminal A2.

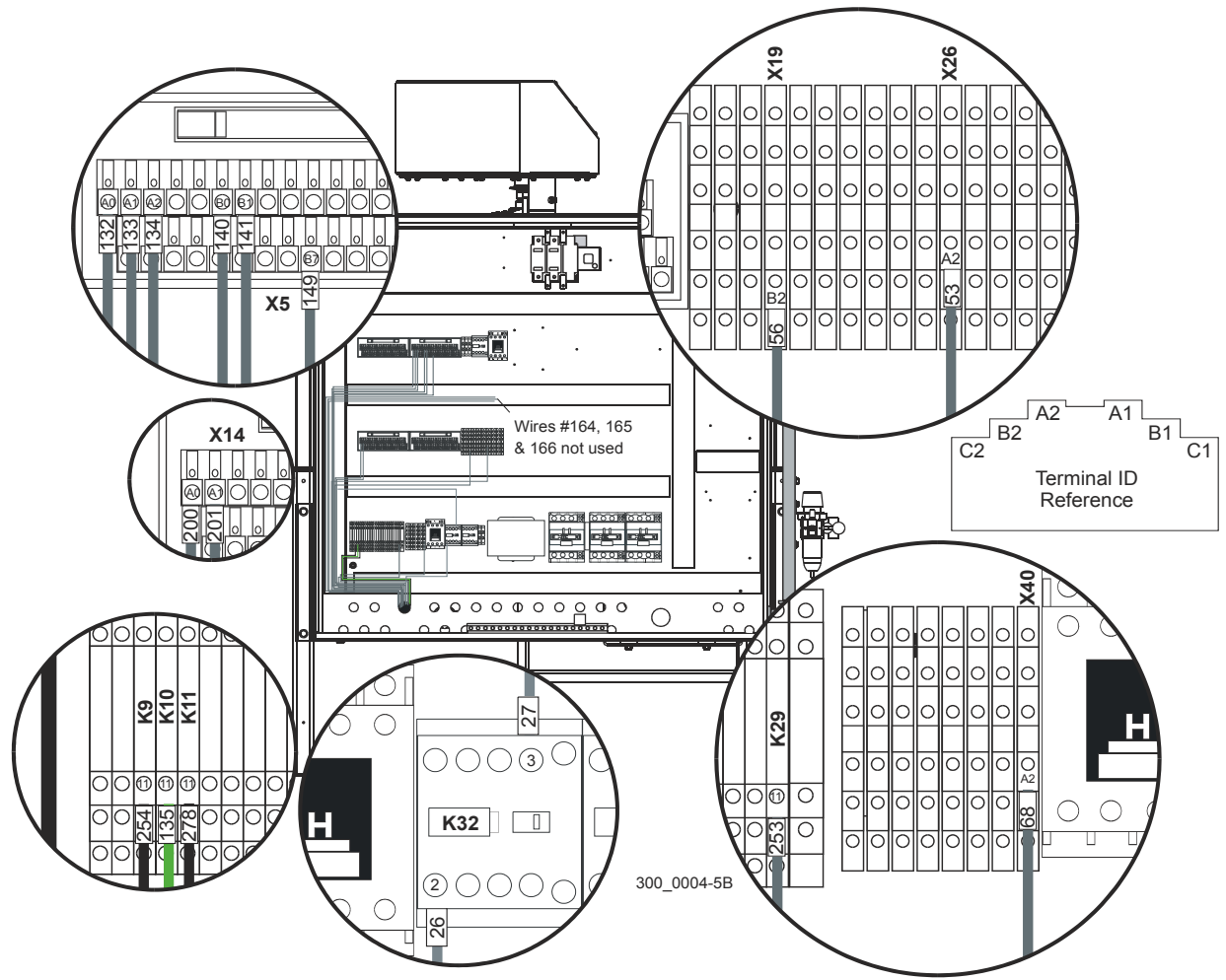

FIG. 3-12

3.4.5 Transducer Cable

See **Figure 3-13**. Route the transducer cable through the wireways to the terminal blocks labeled 510 and 511.

At block 510, connect wire with terminal labeled #510 to terminal #A2. At block 511, connect the wire with terminal labeled #53 to terminal #C2, wire #51 to terminal #B2 and wire #511 to terminal #A2.

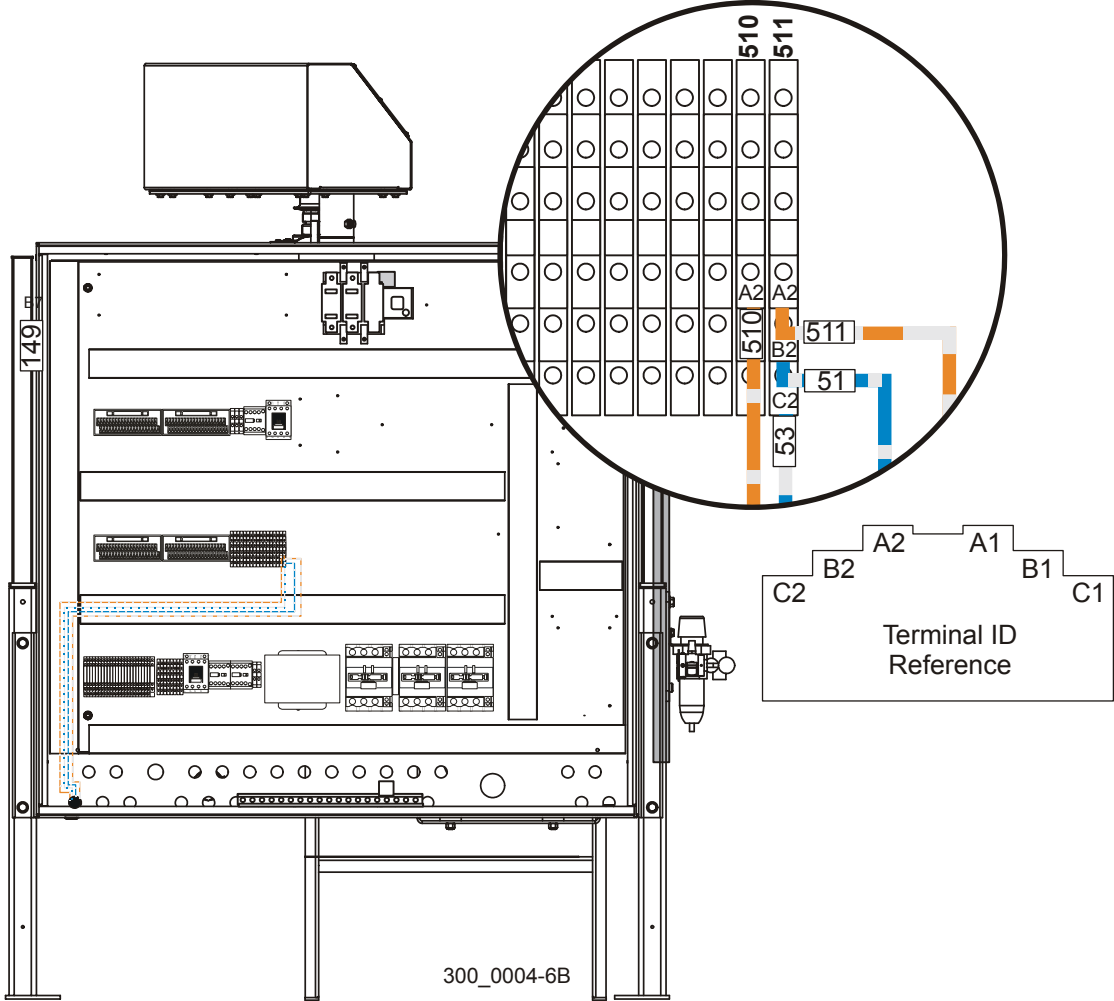

FIG. 3-13

3 Setup

Lubemizer Cable

3.4.6 Lubemizer Cable

See **Figure 3-14**. Route the lubemizer cable wires through the wireways to the relay labeled K6 and the breaker labeled Q10.

Connect wire to relay K6, terminal #2 and to block X40, terminal #A2.

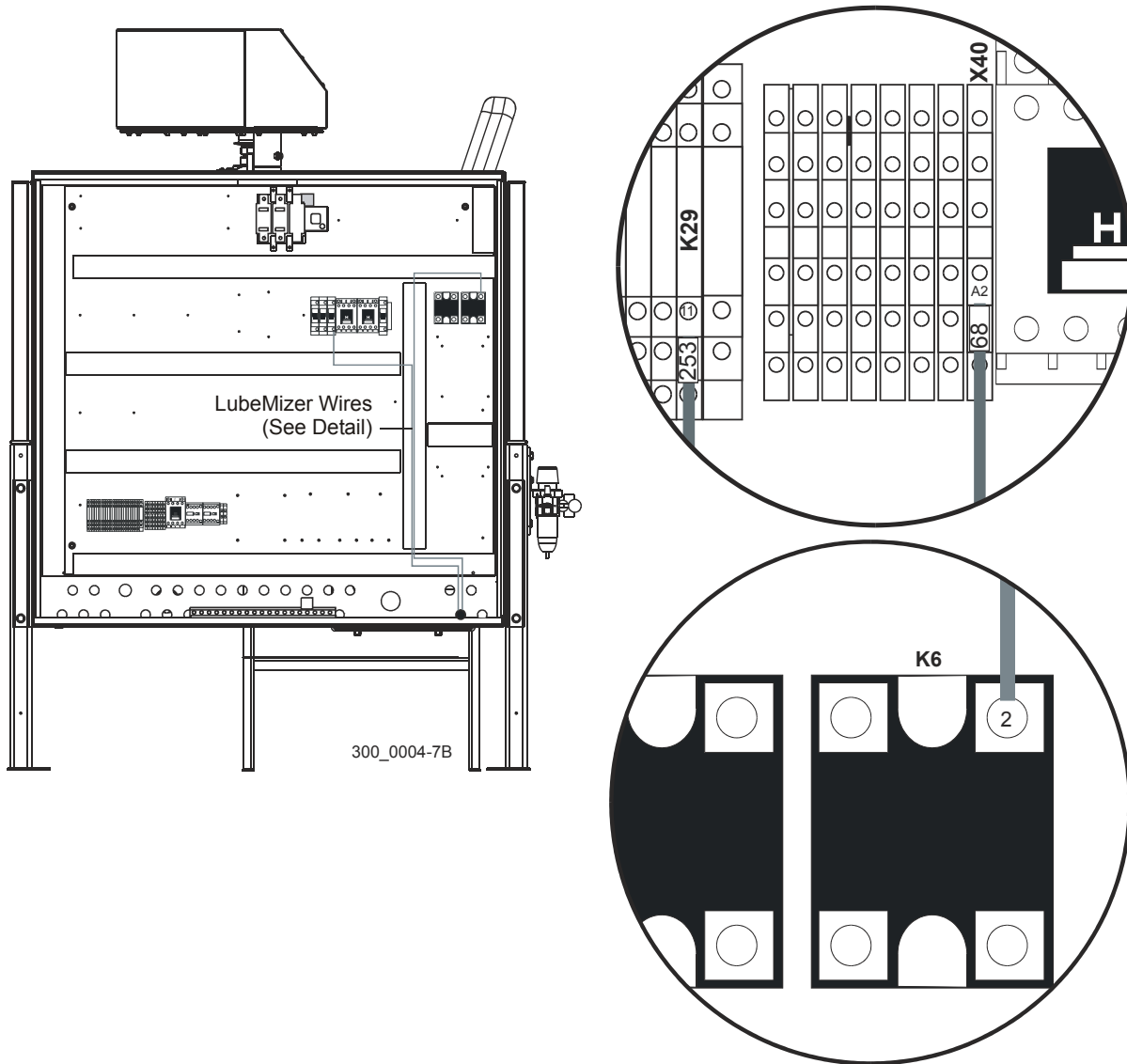

FIG. 3-14

Install the wireway covers after electrical installation is complete.

3.4.7 Debarker Option Foot Switch

See **Figure 3-15**. Place the foot switch on the floor of the operator station and route the cable to the electrical cabinet. Insert the cable through one of the holes in the bottom of the cabinet and secure with the cable connector provided. Connect the green ground wire to the grounding bar in the bottom of the cabinet. Remove wireway covers as necessary and route black wire #378 to PLC module X5 and connect to terminal A5. Route white wire #56 to contactor K1 and connect to terminal 44.

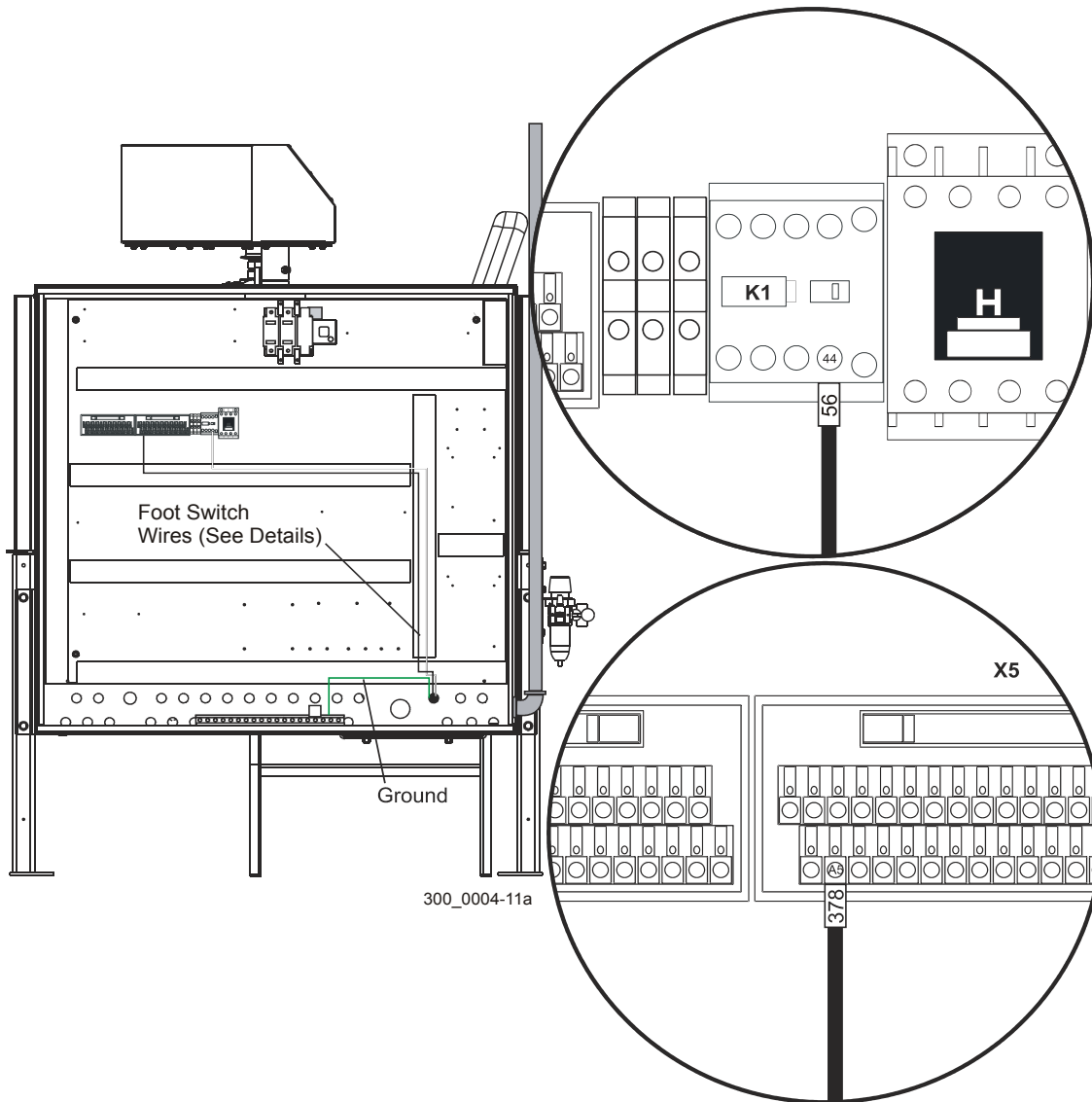

FIG. 3-15

3 Setup

Debarker Option Motor

3.4.8 Debarker Option Motor

See **Figure 3-16**. Install the debarker motor harness to the remaining hole at the bottom of the electrical cabinet and secure with the connector provided. Connect the green ground wire to the grounding bar at the bottom of the cabinet. Route wires #21, 22 & 23 to contactor DB1. Connect wire #21 to DB1 terminal T1, wire #22 to DB1 terminal T2 and wire #23 to DB1 terminal T3.

Route wire #56 to the terminal strip X19 A1. Route wire #379 to PLC module X5 and connect to terminal A6.

Remove existing connection between terminal strip X19 A1 and PLC module X5, terminal A6.

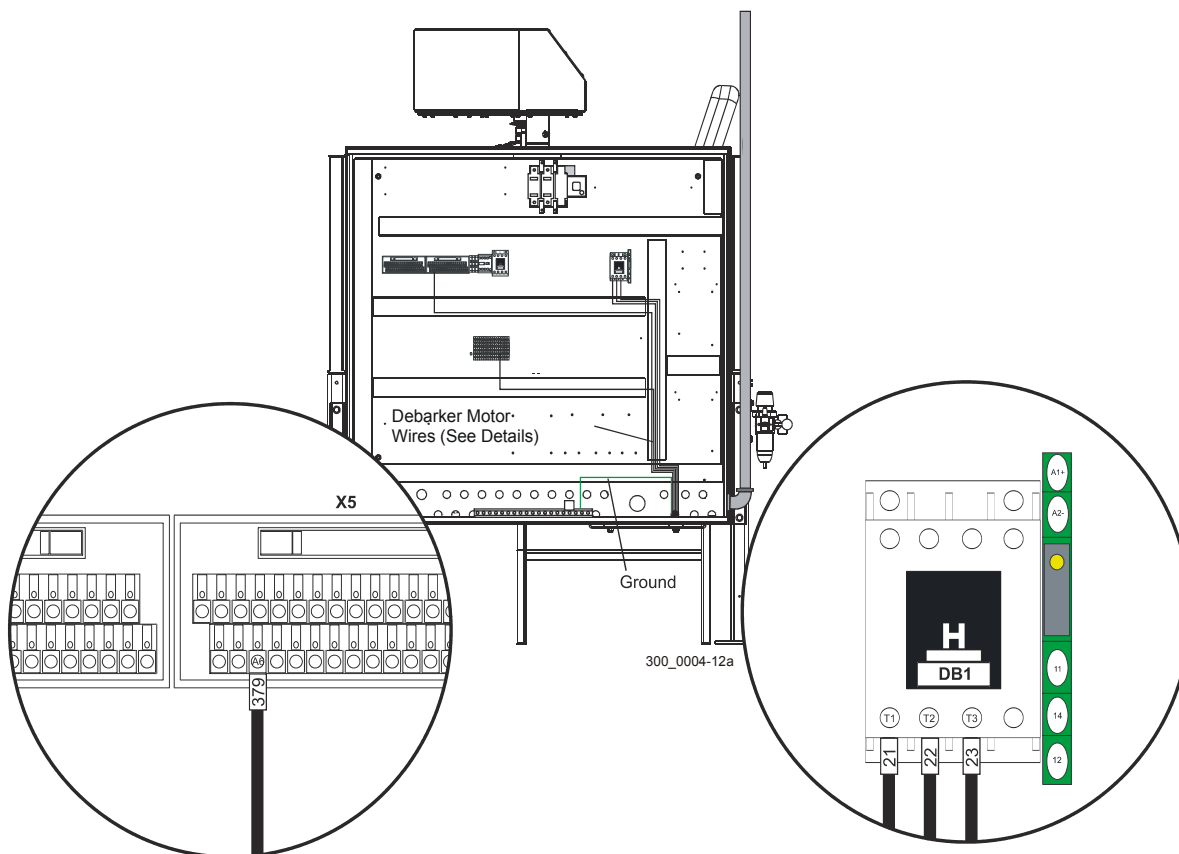

FIG. 3-8

Route the motor harness from the electrical cabinet, underneath the operator station, through the LT300 wireway and cable carrier. Continue routing the harness up the mast through the zippered cable sleeve and underneath the saw motor to the debarker motor. Open the debarker motor terminal housing and use wire nuts to connect wire #21 to debarker wire T1, wire #22 to terminal wire T2, wire #23 to wire T3, wire #56 to wire J2

and wire #379 to wire J1. Connect motor wire T4 to T7, T5 to T8 and T6 to T9. Connect the green ground wire to the motor ground terminal and replace the terminal housing cover.

See Figure 3-17. Install the blue debarker control wires as shown.

Wire #248: PLC module X15, terminal B6 to relay K38, terminal A1.

Wire #278: Contactor DB1, terminal A1 to relay K38, terminal 14.

Wire #68: to relay K38 terminal 11, provided fuse Q9 terminal 2.

Wire #55: Contactor DB1, terminal 13, contactor K4, terminal A1.

Wire #53: Contactor DB1, terminal A2 , relay K38, terminal A2, contactor K4, terminal A2.

Wire #4 from the head/air box labeled "spare" in the electrical box mark as #381. Connect to contactor DB1, terminal 14.

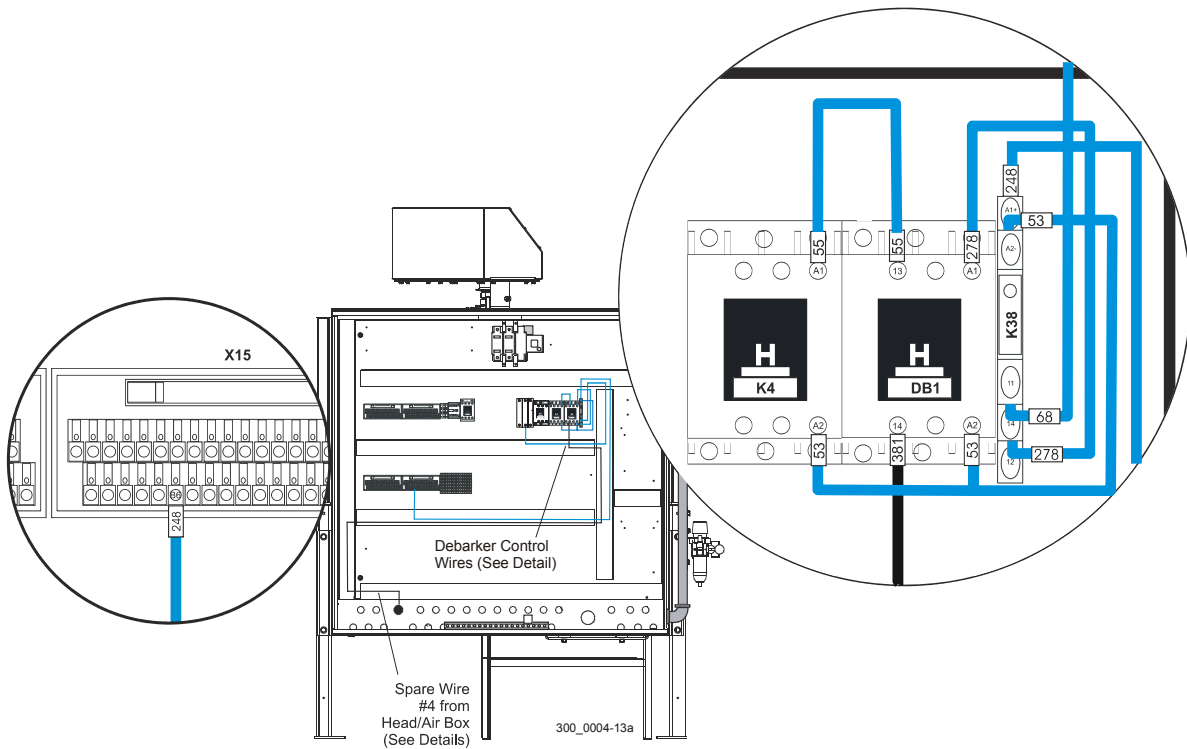

FIG. 3-8

3.5 Hydraulic Installation

See **Figure 3-18**. The log loader assembly is disassembled from the sawmill for shipment. To install the loader, remove the two pivot pins located at the top of the assembly. Place the assembly in position between the brackets on the sawmill frame and secure with the pivot pins. Bolt the pins to the frame brackets with the supplied bolts and lock nuts.

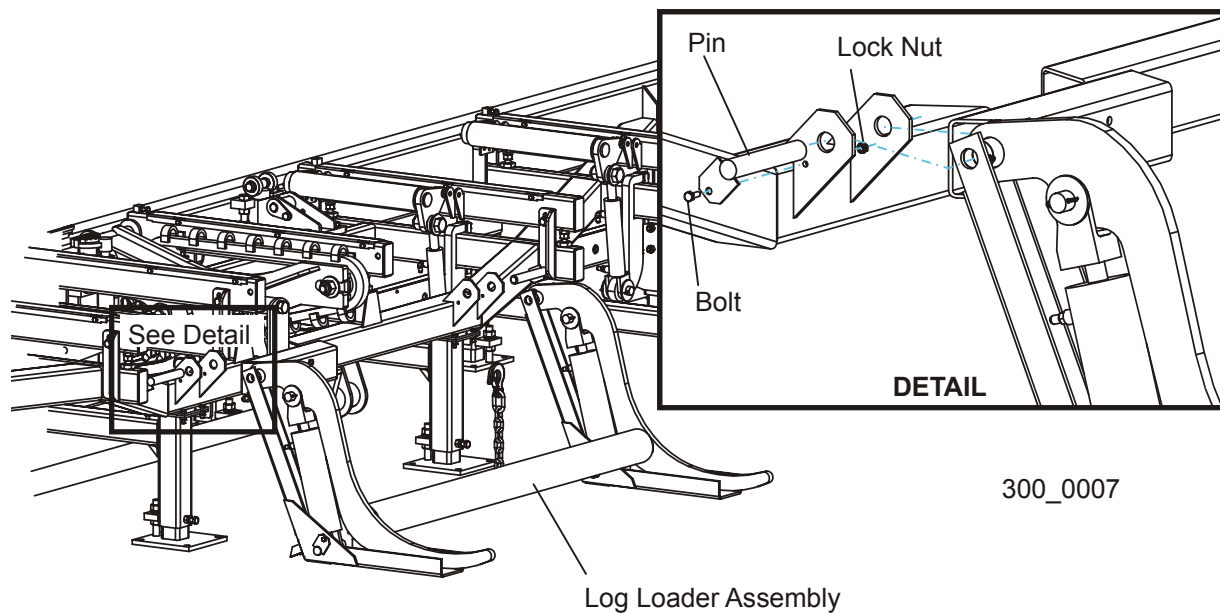

FIG. 3-18

Remove the plugs from the loader hydraulic hoses and connect to the fittings on each cylinder (two hoses per cylinder).

See Figure 3-19. The hydraulic manifold is located under the operator station floor. Remove the plugs from the manifold fittings and identify the labeled hoses extending from the sawmill frame. Remove the plugs from the hoses and connect each hose to the appropriate fitting on the manifold.

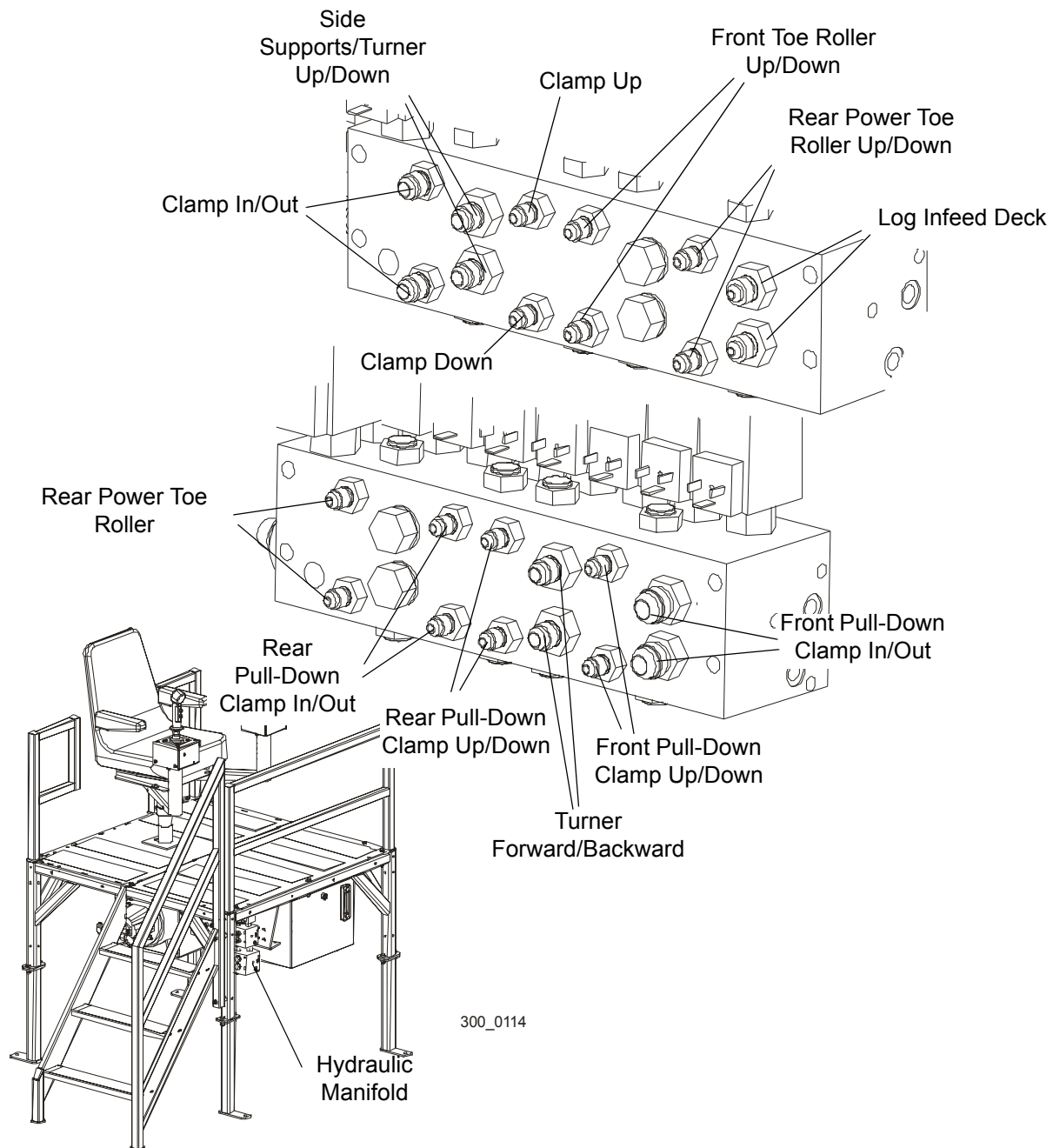

FIG. 3-19

3.6 Sawmill Installation

Position the sawmill approximately 10 inches from the operator station. Position the sawmill horizontally so the outside of the main frame tube is aligned with the inside of the operator station leg. Check the position of the operator station in relation to the sawmill. Sit in the operator seat and check the view of the log clamp and side supports. The operator station may be moved in the horizontal direction slightly to obtain the desired view of the sawmill.

After the sawmill is positioned, make sure the horizontal locking bolt and top adjustment nut on each leg is loose. Anchor the sawmill to the floor with 1/2" anchor bolts and nuts. At some foot locations, you may not be able to drill all four anchor bolt holes. Use at least two holes at each foot location.

Remove the saw head rest assembly located under the outer side of the saw head and the saw head rest block located under the inner side of the saw head.

See Figure 3-20.

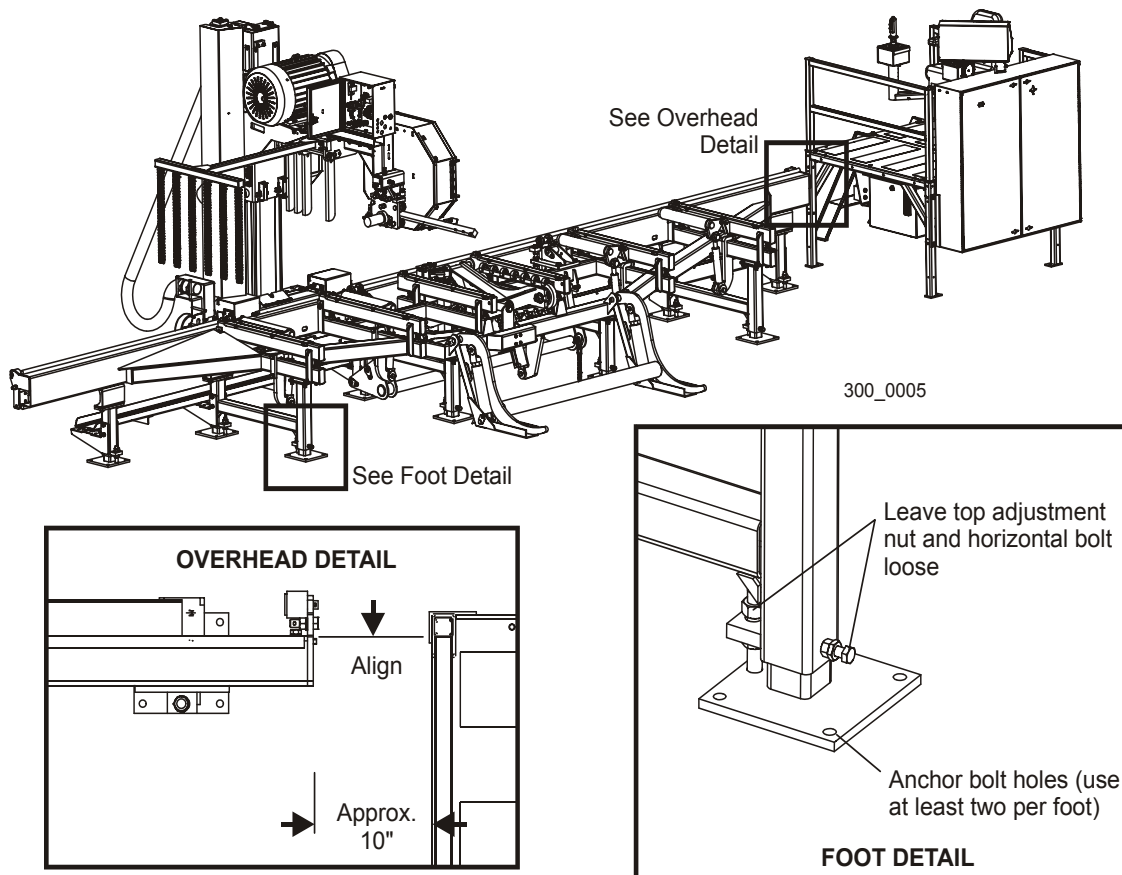

FIG. 3-20

3.7 Air Installation

See **Figure 3-21**. Locate the air service assembly at the rear of the operator station. Install a 1/2" NPT quick disconnect fitting to the elbow fitting supplied in the air valve. Connect the incoming air supply line (minimum 1/2" air hose) to the quick disconnect fitting. Connect the two air line from the sawmill to the tube fittings supplied on either side of the air regulator/filter. Install the line labeled "Blow-Off Supply" to the 'T' fitting between the air valve and regulator. Install the line labeled "Tension Air Supply" to the elbow fitting on the regulator. To install each line, push the fitting collar in, insert the hose and release the collar.

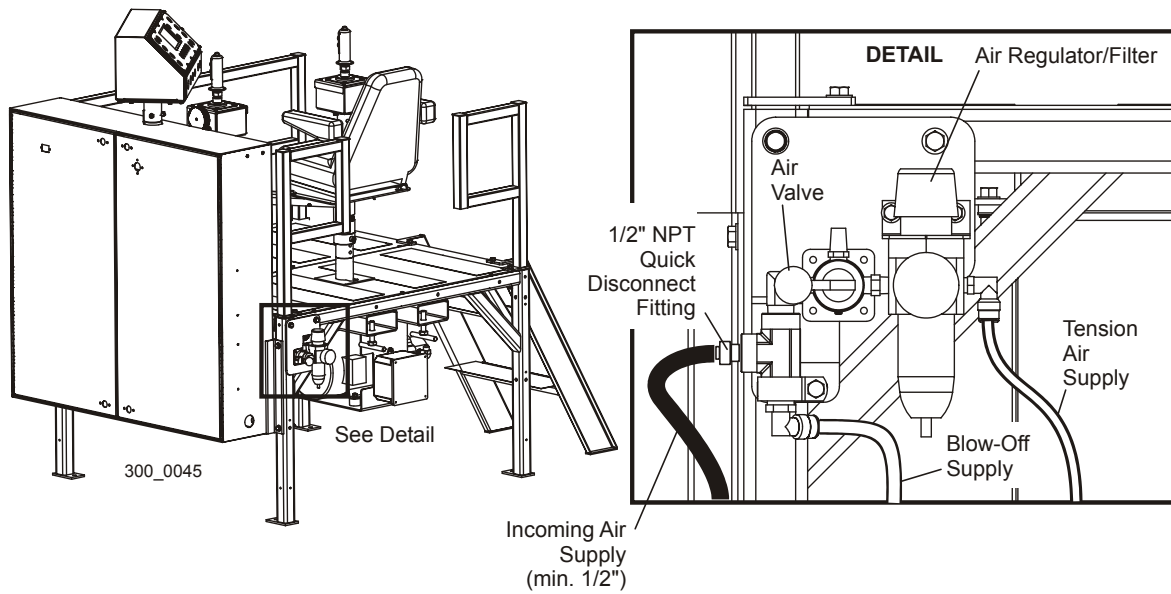

FIG. 3-21

3.8 Sawmill Installation Setup

Once the sawmill is in place and anchored to the floor, you are ready to setup the sawmill for operation. The first step should be aligning the sawmill bed sub-frame. A transit maybe used for this procedure, however a laser-style level is recommended because it is easier and more accurate.

NOTE: This procedure is intended to be performed by factory personnel during initial installation using the appropriate equipment. Refer to the alignment section for subsequent adjustments to sawmill ([See SECTION 7 Alignment](#)).

3.8.1 Level Sub-Frame

Set the laser level at a location so the beam is positioned five inches above the top track rail. Move the saw head so it positioned over the log clamp tube at the middle of the bed frame.



CAUTION! Avoid raising or lowering the saw head against the upper or lower travel limits until after the transducer has been properly adjusted ([See Section 3.9.1](#)). Failure to do so may result in damage to the machine.

Measure the distance from the top track rail to the laser beam at four locations along the tube. Once you have four measurements, determine a target dimension that splits the difference of the four dimensions taken.

See Table 3-1. Suppose the four dimensions from track rail to the laser beam are as shown below. The 5 1/4" dimension should be the target as this will require the least adjustment at each location.

| Front | Front Middle | Rear Middle | Rear | Target |
|--------|--------------|-------------|--------|--------|
| 5 1/4" | 5" | 5 1/2" | 5 1/4" | 5 1/4" |

TABLE 3-1

See Figure 3-22. To level the main bed tube, measure the distance from the top track rail to the laser beam at one of the leg locations. Move the saw head if necessary to remove weight from the leg. Use the lower adjustment nut to raise or lower the appropriate leg until the target dimension is obtained ($\pm 1/16$ ""). Lock the leg in position by tightening the top nut and the horizontal locking bolt. Repeat at each leg location along the length of the main bed tube.

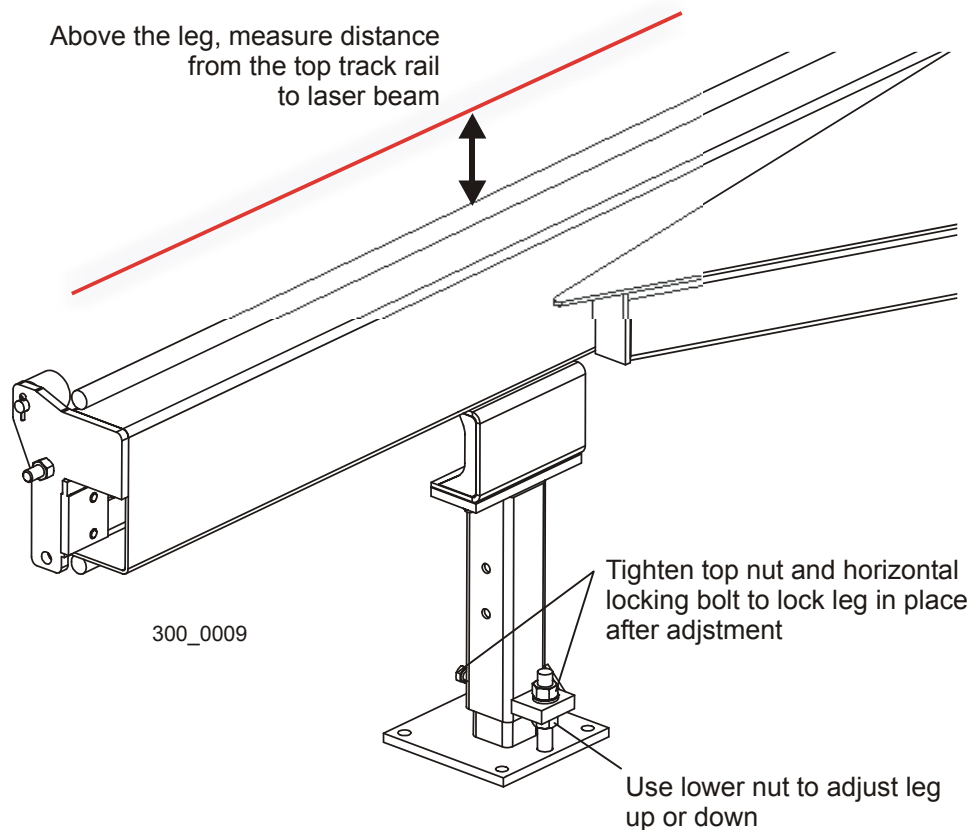

FIG. 3-22

After all of the legs have been adjusted and locked, move the saw head back to the rear of the bed (furthest from operator station). Measure the distance from the top track rail to the laser beam at the log clamp tube location. If the measurement is more than $1/16$ " more or less than the target dimension determined above, adjust one of the two middle inside legs to push or pull the tube until it is level. Loosen the horizontal locking bolt and upper adjustment nut on the leg and adjust the leg using the lower adjustment nut. Retighten the top nut and horizontal locking bolt after adjustment is complete.

3 Setup

Level Sub-Frame

See **Figure 3-23**. To level the bed sub-frame in the other direction, place two pieces of straight tubing between the front two bed rail supports. Measure from the front end of each tube to the laser beam. Adjust the outer front leg to level the bed so both measurements to the tubes are the same ($\pm 1/16$ "). Leave the horizontal locking bolt and top adjustment nut loose for now. Repeat at the other end of the tubes using the second outer leg to adjust. Move the straight tubes to the rear two bed rail supports and adjust the two outer rear legs until the bed is level ($\pm 1/16$).

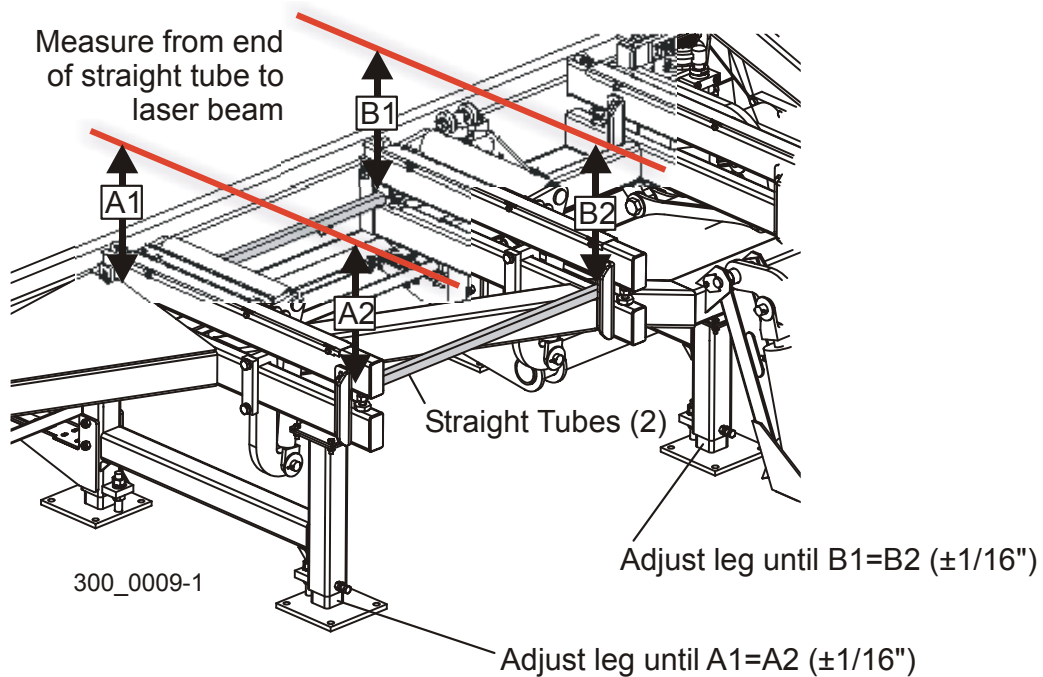



FIG. 3-23

3.8.2 Level Saw Head

Install a blade around the blade wheels. Tension and track the blade. Move the saw carriage so the blade is positioned over the log clamp tube. Adjust the blade guide arm all the way out.

 **WARNING!** DO NOT use blades with stress cracks. Blades with stress cracks can shatter causing bodily injury and/or machine damage.

See Figure 3-24. Standard Roller/Block Guides: Loosen clamp bolt (H) and turn the top guide block bolt (F) counterclockwise to raise the top guide block off the blade. Turn blade guide assembly bolt (A) counterclockwise to move the bottom guide block down off the blade. Check that the blade guide roller does not touch the blade. Loosen screws (G) and (I) and move the guide assembly back away from blade.

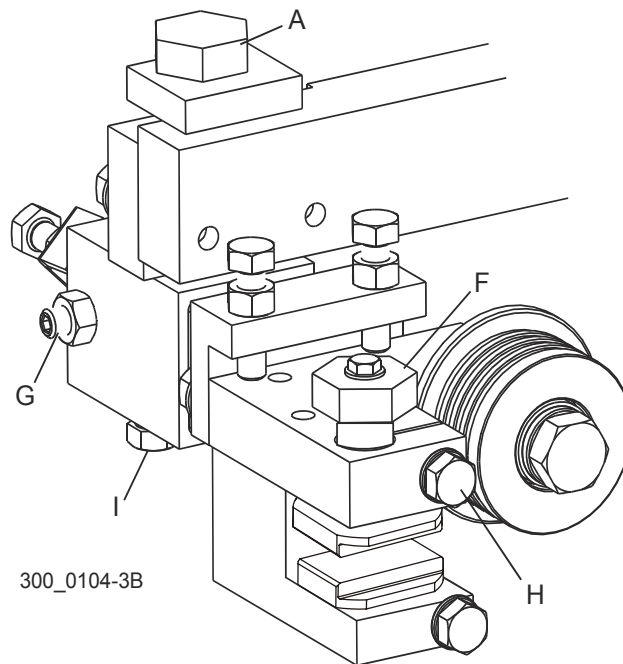

FIG. 3-24

See Figure 3-25. Optional Block Guides: Adjust the blade guides so they do not touch the blade in any way. Loosen clamp bolt (H) and turn the top guide block bolt (F) counterclockwise to raise the top guide block off the blade. Turn blade guide assembly bolt (A) counterclockwise to move the bottom guide block down off the blade. Check that the blade guide roller does not touch the blade. Loosen clamp bolt (G) and turn roller bolt

3 Setup

Level Saw Head

(C) if necessary to move roller away from blade.

FIG. 3-25

See Figure 3-26. Raise the saw head until the blade is approximately 15" above the clamp tube. Hang a tape rule from the blade near the inner blade guide assembly. Make sure the tape does not contact an upward set tooth. Check the measurement from the blade to the laser beam. Move the tape rule near the outer blade guide assembly and measure to the laser beam. The two measurements should be equal. If necessary, adjust the lower track rollers to tilt the saw head so the blade is parallel to the laser beam.

To tilt the outer side of the saw head down toward the bed, loosen the adjustment bolts. Turn each adjustment bolt equally, one revolution at a time and remeasure the distance from the blade to the laser beam. Once the blade is parallel to the laser beam, tighten the stop bolts until they stop against the roller mount block.

To tilt the outer side of the saw head up, loosen the stop bolts and tighten the adjustment bolts. Turn each adjustment bolt equally, one revolution at a time and remeasure the distance from the blade to the laser beam. Once the blade is parallel to the laser beam, tighten the stop bolts until they stop against the roller mount block.

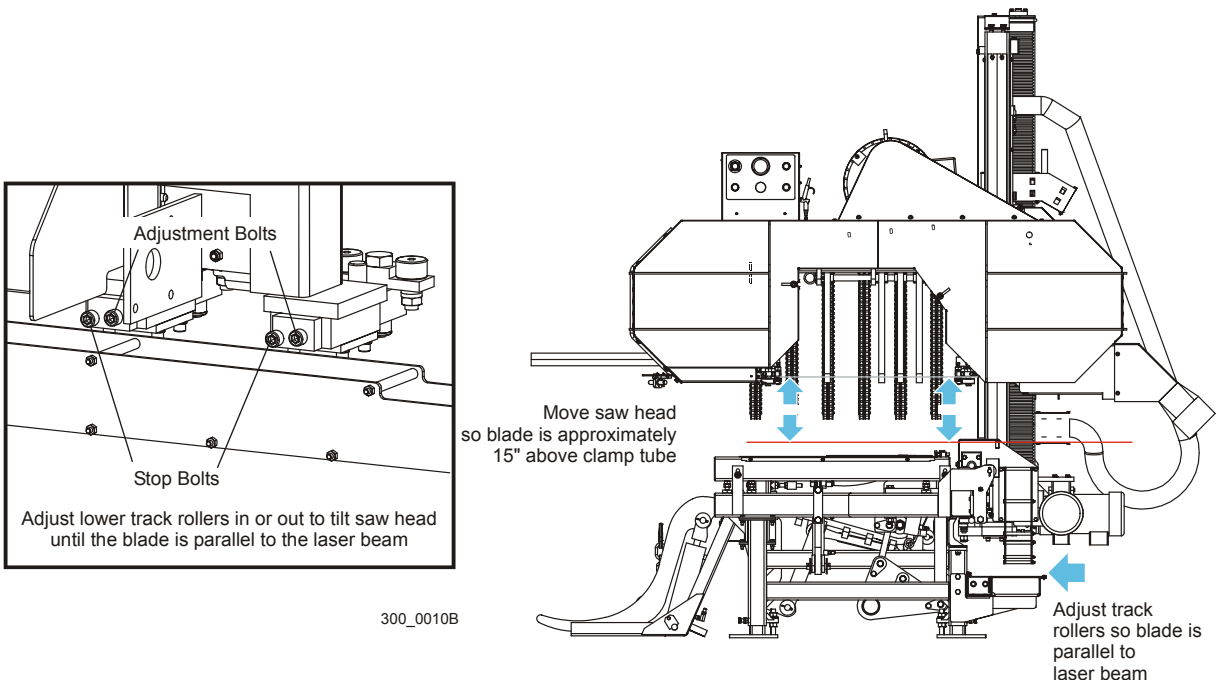

FIG. 3-26

3

Setup Level Saw Head

See **Figure 3-27**. Now that the blade is parallel to the laser beam at the clamp location, check the alignment at each leg location along the main frame tube. Move the saw head to the first leg location and measure from the blade to the laser beam at both blade guide assemblies. If the measurements are not the same, adjust the outer leg. Turn the bottom adjusting nut to raise or lower the leg until the blade is parallel to the laser beam. Lock the leg in position by tightening the horizontal locking bolt and top adjustment nut. Repeat adjustment at each leg location down the length of the frame tube. Return to the first leg, recheck the blade alignment, fine-tune if necessary and retighten the horizontal locking bolt and top adjustment nut.

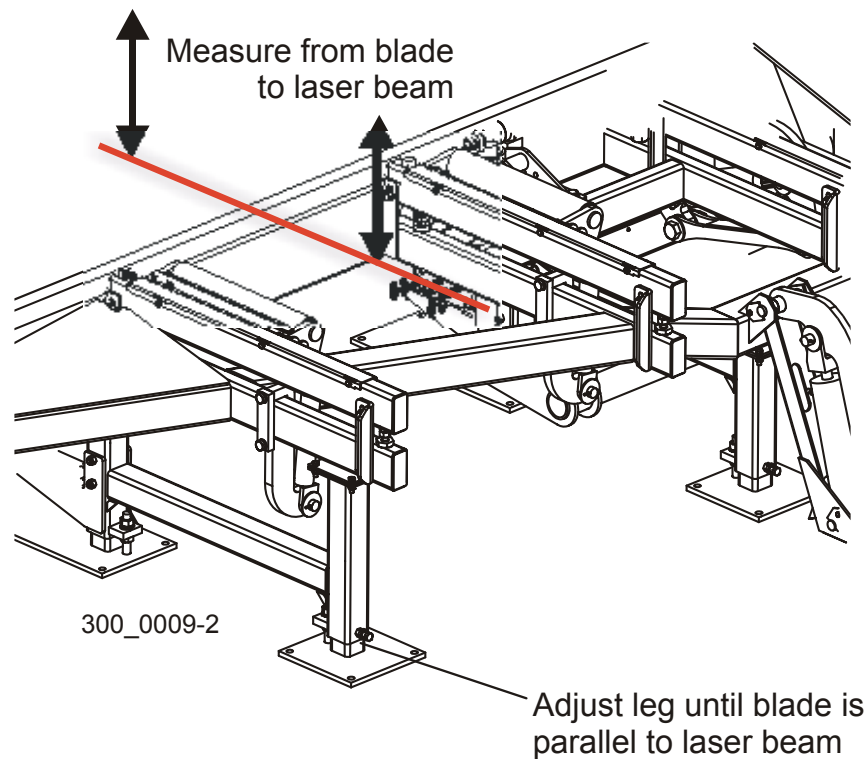

FIG. 3-27

3.8.3 Level Bed Rails

See Figure 3-28. Adjust the bed rails to $5/16$ " above the log clamp. Move the log clamp in until it is 10" from the clamp stop. Adjust the clamp down to its lowest position. Measure the distance from the laser beam to the clamp (i.e. 5"). Measure the distance from the first bed rail to the laser beam at both ends of the bed rail. If necessary, loosen the bed rail clamp bolts and turn the adjustment bolt to raise or lower the end of the bed rail so it is $5/16$ " above the clamp (i.e. $4 \frac{11}{16}$ " [$\pm 1/16$ "]). Retighten the bed rail clamp bolts. Repeat adjustment as necessary at each bed rail.

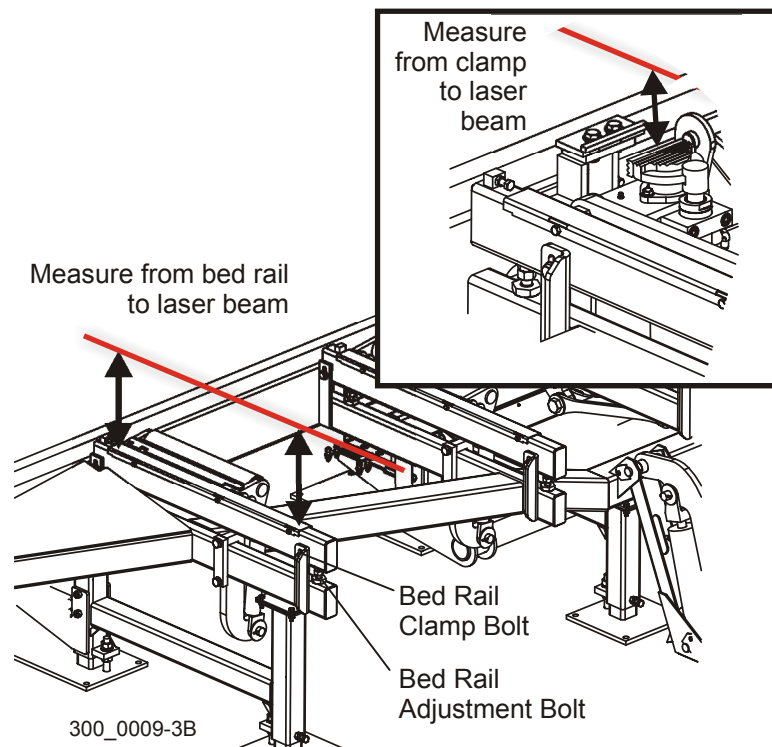

FIG. 3-28

Move the saw head so the blade is positioned over the first bed rail. Open the blade guide arm all the way open. Measure from the bottom of the blade to the bed rail at each end of the rail. If the two measurements differ by more than $1/16$ ", recheck the measurement from the bed rail to the laser beam and adjust the bed rail as necessary. Move the saw head to each bed rail and repeat procedure until all bed rails are parallel to the blade and laser beam within $1/16$ ".

3

Setup

Level Blade Guide Arm

3.8.4 Level Blade Guide Arm

See **Figure 3-29**. Adjust the blade guide arm all the way in. Measure from the bottom of the arm to the laser beam at both ends of the arm. The two measurements at each end of the arm should be the same within $1/32$ ". To adjust the vertical tilt of the arm, adjust the bolts (C & D) on the blade guide arm mounting plate. Loosen the jam nuts. Adjust bolt (C) up and bolt (D) down to tilt the arm up. Adjust bolt (D) up and bolt (C) in to move the arm toward the blade. Recheck the distance from the arm to the laser beam at both ends of the arm. Readjust if necessary. Tighten the jam nuts.

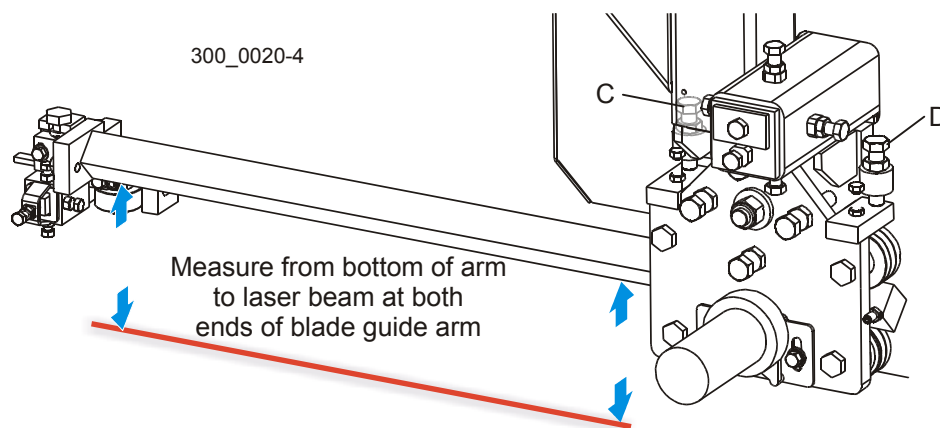

FIG. 3-29

Adjust the blade guides for sawing.

See Figure 3-30. Standard Roller/Block Guides: Move the guide assembly forward until the roller flange is 1/16"-1/8" from the back edge of the blade and tighten clamp bolts (G) and (I). Turn blade guide assembly bolt (A) clockwise to raise the bottom guide block up until it touches the blade, but does not deflect it upward. Turn top guide block bolt (F) clockwise to move top block down until it touches the blade, then back 1/4 turn. Tighten clamp bolt (H). Repeat for other blade guide assembly.

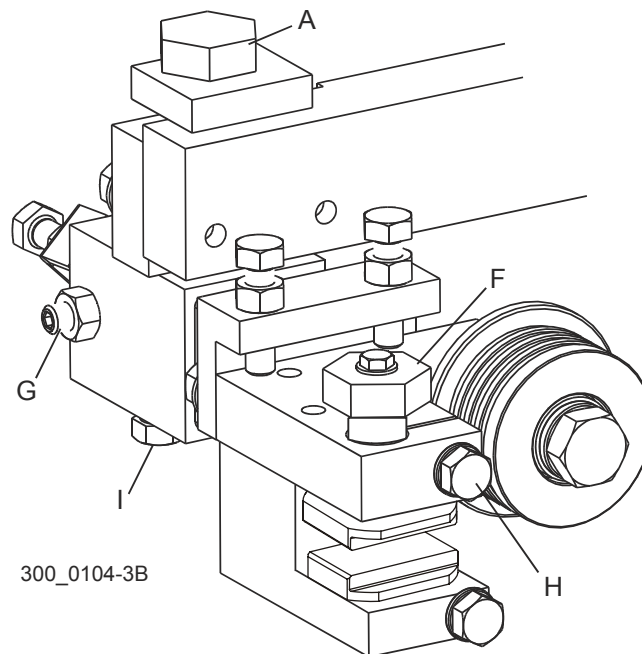

FIG. 3-30

3

Setup

Level Blade Guide Arm

See Figure 3-31. Optional Roller/Block Guides: Turn blade guide roller bolt (C) to move the roller so it is 1/16"-1/8" from the back edge of the blade and tighten clamp bolt (G). Turn blade guide assembly bolt (A) clockwise to raise the bottom guide block up until it touches the blade, but does not deflect it upward. Turn top guide block bolt (F) clockwise to move top block down until it touches the blade, then back 1/4 turn. Tighten clamp bolt (H). Repeat for other blade guide assembly.

FIG. 3-31

3.8.5 Side Support Setup

See Figure 3-32. An alternate location for the front side support is available to use if you handle short logs (less than 8 feet long). Unfasten the front side support from the link bar and unbolt the assembly from the bed frame. Relocate the assembly to the alternate position and secure with the previously removed hardware. Check the side support alignment ([See Section 7.1.5](#)).

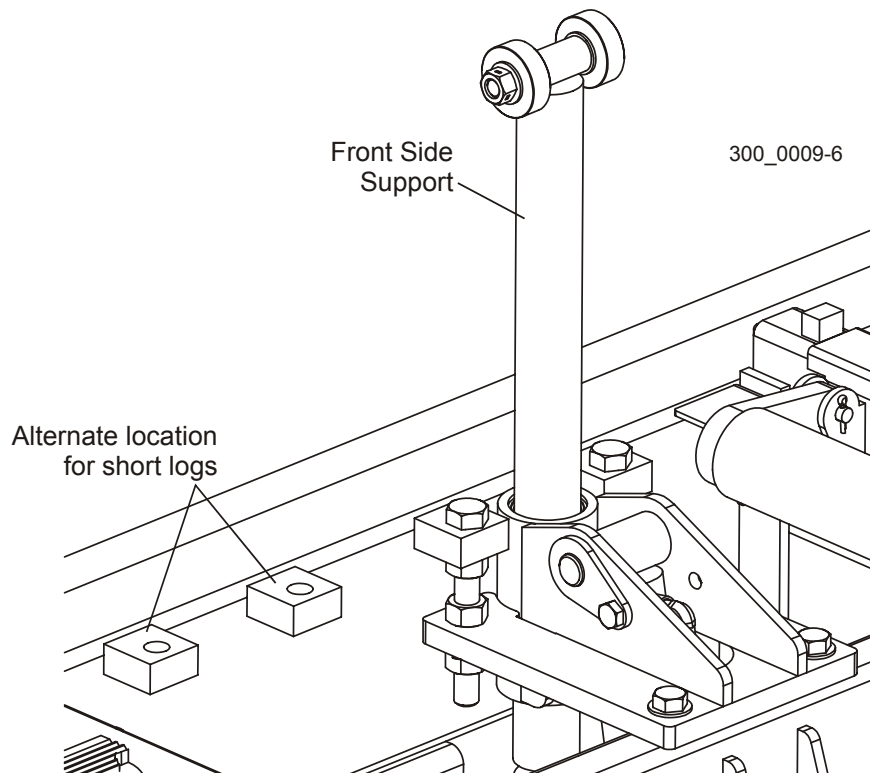

FIG. 3-5

3.9 Initial Control Programming

After the sawmill is installed and ready to operate, the control should be programmed. Reprogramming will also be required if the control CPU or transducer sensor is replaced.

3.9.1 Blade Height Calibration

Perform the three procedures described below to ensure that the control accurately displays the position of the blade above the bed rails. Push the green START button to activate the machine.

Sensor Calibration

1. Move the saw head so the blade is positioned 1" - 1 1/2" from a bed rail.
2. Use a tape rule to measure the actual distance from a bed rail to a down-set tooth on the blade (measure at a point over the bed rail closest to the saw head mast).
3. Check the display reading on the sawmill control. If the reading does not match the actual measurement, adjust the transducer located on the saw head mast.

See Figure 3-33. Loosen the three transducer clamp brackets and slide the transducer up or down until the control displays the correct reading. This is easiest done with a second person sitting at the control as you adjust the transducer. Tighten the clamp brackets to secure the transducer in position.

 **CAUTION!** Do not overtighten the sensor bracket screws. Damage to the sensor may result.

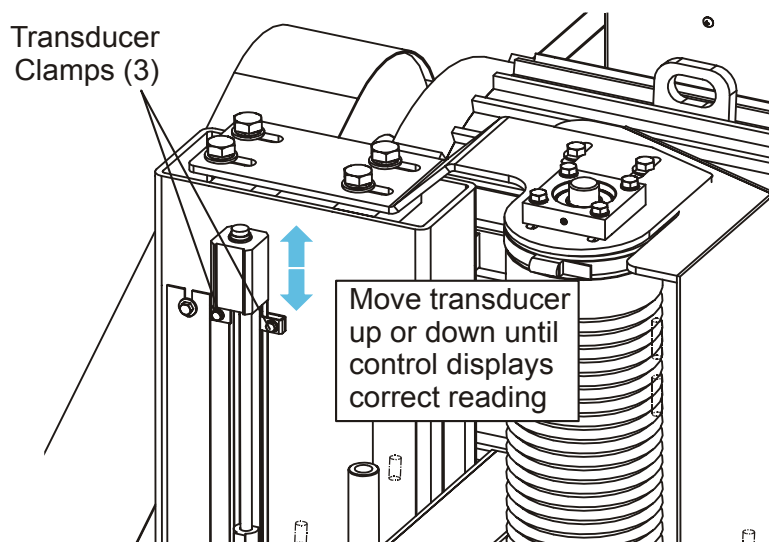

FIG. 3-33

Sensor Linearity Adjustment

NOTE: Perform the Sensor Calibration procedure described above prior to checking and adjusting the Sensor Linearity.

1. Raise the saw head so the blade is positioned approximately 1" below the top stop.
2. Measure the distance from the same down-set tooth to the bed rail and compare to the reading on the display. If the measurement and display reading differ more than 1/32", adjust the sensor Cal Value as described in the next steps.

NOTE: The Calibration value is recorded on the transducer sensor housing located at the top of the saw head mast. In most cases, this value is what should be entered into the control.

3. Turn the key switch to the Program position and push the Ref Lock button to display the Cal Value. The value is displayed in whole numbers. Each increment of 5 is equal to approximately 1/32".
4. Use the Up or Down buttons to adjust the value. If the actual measurement from the blade to the bed rail was greater than the displayed height value, increase the Cal Value. If the actual measurement was less than the displayed height value, decrease the Cal Value.
5. Press the Select button to store the new value. Record the value for future reference: Cal Value _____.
6. Turn the key switch to the Off position and verify that the displayed height value is now the same as the actual distance from the blade to the bed rail (within 1/32"). Repeat the Linearity Value adjustment as necessary.
7. Repeat the Sensor Calibration and Sensor Linearity adjustments until the correct height value is displayed with the saw head at the lower and upper ends of the mast.

Final Sensor Check

1. Move the saw head so the blade is between 17" and 18" from the bed rail.
2. Measure the distance from a downset tooth on the blade (measure at a point over the bed rail closest to the saw head mast).
3. Verify that the displayed height value is the same as the actual measurement from the blade to the bed rail (within 1/32"). If not, repeat the Sensor Linearity Adjustment procedure above, then repeat the Final Sensor Check.

3.9.2 Upper Saw Head Travel Limit

This option is available if the area where the sawmill is installed does not have enough height clearance to allow the saw head to travel to the top of the mast. To set the Upper Saw Head Travel Limit, first position the saw head at the height where you want it to automatically stop. Turn the key to the Program position and push the Ref 2 button. Push the Select button to set the limit at the current saw head position.

3.9.3 Power Feed Calibration

Calibrate the power feed dial. With the key switch still in the Program position, push the Last Cut button. Turn the power feed dial in one direction until it stops. Push the Select button. Turn the power feed dial the other direction until it stops and push Select again.

3.9.4 Kerf

The kerf value is automatically added to the board thickness setting to compensate for the thickness of the blade. The default factory value is .19. Adjustment of this value may be necessary if you use different thicknesses of blades or unusual tooth set configurations.

SECTION 4 OPERATION

4.1 Control Overview

LT300 control was designed to allow the operator to control the sawing operation with minimal effort and movement.

See Figure 4-1. The control includes several sets of buttons for controlling how the sawmill is programmed to cut a log. The control box also includes controls to start and stop the machine. A description of each control component is provided below.

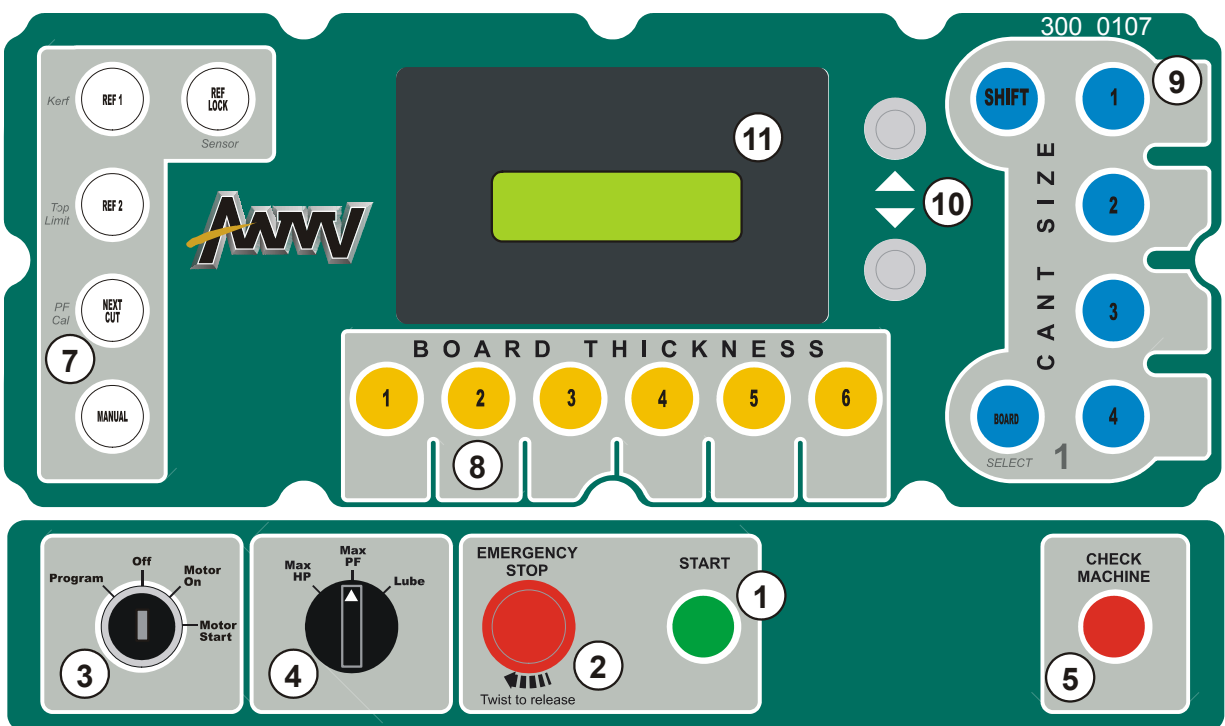

FIG. 4-1

1. **START** - Push the START button to turn on electrical power to the machine.
2. **EMERGENCY STOP** - Push this button to turn off electrical power to the machine. To release the stop, turn the button clockwise and release so the button pops up.
3. **Key Switch** - Turn the key switch to MOTOR START to start the blade motor. Release the key to the MOTOR ON position to allow the blade motor to continue running. Turn the key switch to OFF to stop the blade motor. Use the PROGRAM position of the key switch to reprogram certain controls described later.

4. Selector Switch - Allows the operator to specify values for the MAX HP, MAX PF, and LUBE pulse. These options will be explained later in the manual.
5. CHECK MACHINE - This light warns the operator that a problem has occurred. The specific problem will be indicated on the display.
6. Temporary Reference Buttons - Programmable buttons for advanced sawing methods.
 - REF LOCK (Sensor)
 - REF 1 (Kerf)
 - REF 2 (Top Limit)
 - LAST CUT (PF Cal)
 - MANUAL
7. BOARD THICKNESS - Six programmable buttons the operator can use to automatically drop the blade a pre-determined distance. A dry-erase marker can be used to temporarily label the area below each button with its value.
8. CANT SIZE - Four programmable buttons that determine the size of the cant left after sawing boards from the log. A dry-erase marker can be used to temporarily label the area to the right of each button with its value.

The SHIFT button allows twelve settings for the four pattern buttons. Push the SHIFT button once. The SHIFT button will illuminate indicating pattern settings 5-8 are active. Push the SHIFT button a second time. The SHIFT button will flash indicating pattern settings 9-12 are active. Push the SHIFT button again to turn off and return to pattern settings 1-4.

9. Up/Down Buttons - Used to increase or decrease values when programming the control.
10. Display - During the sawing operation, the display shows the current blade height location and the board thickness values currently being used. The display also displays error messages or values of certain features when the control is being programmed.

4.2 Distribution Box Overview

See **Figure 4-2**. The distribution box on the saw head contains controls for the blade tension. The box also includes lights that indicate which mode (head or bed) that the joystick controls are currently set to. The control box also includes controls to start and stop the machine. A description of each box component is provided below.

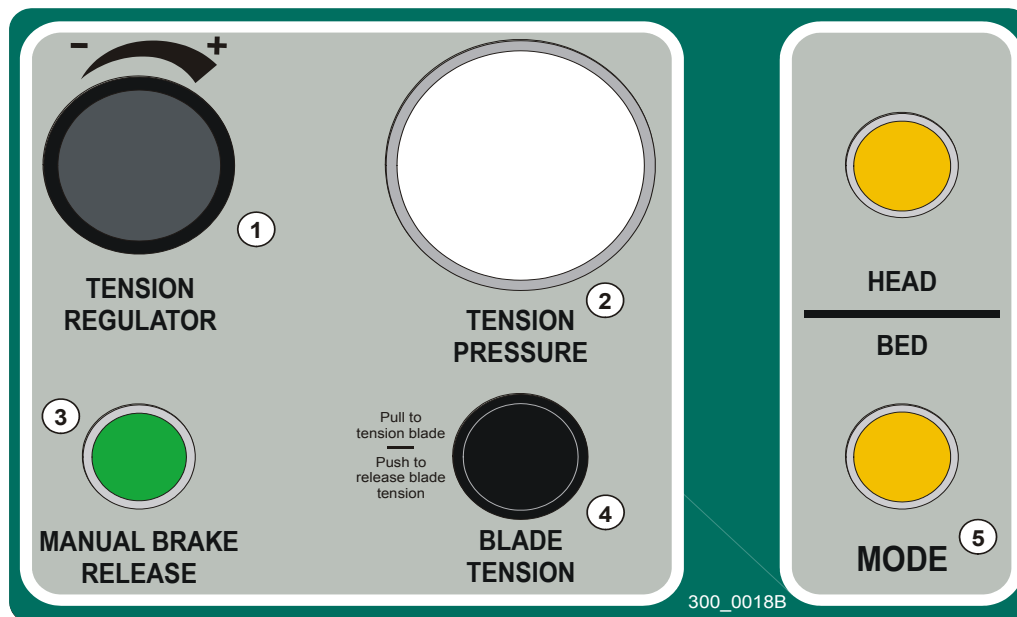

FIG. 4-2

1. **TENSION REGULATOR** - Turning this knob adjusts the blade tension pressure. Turn the knob clockwise to increase blade tension, counterclockwise to reduce blade tension.
2. **TENSION PRESSURE** - Gauge indicates current blade tension pressure.
3. **MANUAL BRAKE RELEASE** - Push in and hold to release the blade wheel brake.
4. **BLADE TENSION** - Push in to release the blade tension, pull out to tension the blade.
5. **MODE** - Two lights indicate the current mode of the joystick controls. The top button on the left joystick toggles the joystick controls between head and bed functions.
 - **HEAD** - When lit, the joystick controls are in head mode. The joysticks can be used to operate saw head functions (saw head up, down, forward, reverse, cruise control, board blow-off and blade guide arm in or out).
 - **BED** - When lit, the joystick controls are in bed mode. The joysticks can be used for log handling functions (loader, clamp, turner, side supports and rollers).

4.3 Joystick Control Overview

The joysticks located at the operator seat control all of the saw head and bed functions. Each joystick can be moved forward, backward, left and right to perform various functions. Each joystick also has three buttons to perform additional functions. One button is located at the top of the joystick and two on the side of the joystick.

To toggle between head and bed functions, push the button at the top of the left joystick. The MODE light on the saw head distribution box will indicate if the controls are in bed mode or head mode.

See Figure 4-3. In HEAD mode, push the right joystick forward to move the saw head away from the operator station. Hold the joystick forward for 10 seconds to turn on the oiler. Pull the right joystick back to bring the saw head forward toward the operator station (cutting direction). Rotate the feed rate dial next to the left joystick to adjust the speed of the saw head in the cutting direction. Rotate the dial toward you to speed up the feed rate, away from you to slow the feed rate down. The saw head automatically moves in reverse at full speed.

Push the top side button on the right joystick to raise the saw head and push the bottom side button to lower the saw head.

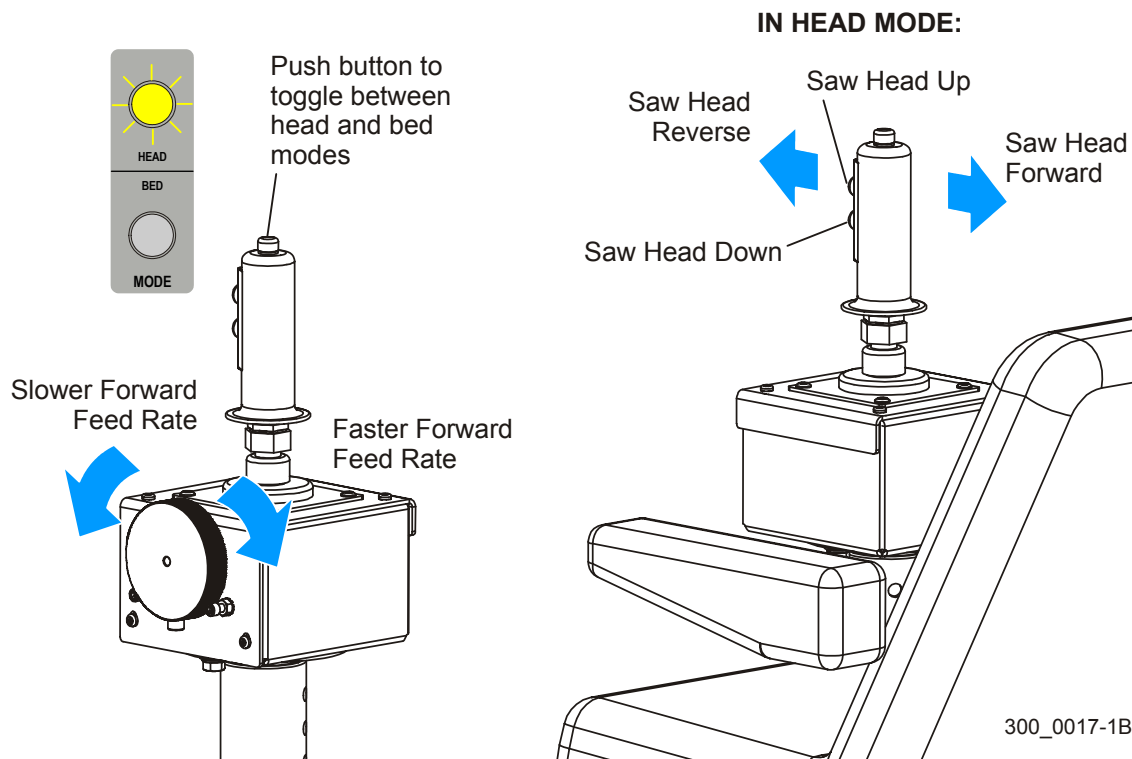

FIG. 4-3

See Figure 4-4. The right joystick also adjusts the outer blade guide arm in and out. Push the joystick to the right to move the blade guide in toward the log. Push the joystick to the left to move the blade guide out away from the log.

Pushing the top button on the right joystick once with the saw head moving forward turns the cruise on and off. Pushing and holding the button with the saw head moving in reverse turns the air blow-off on to blow sawdust off the wood.

The top side button on the left joystick raises the saw head 3/4" so you can return the saw head after a cut without dragging the blade. These functions are described later in the manual.

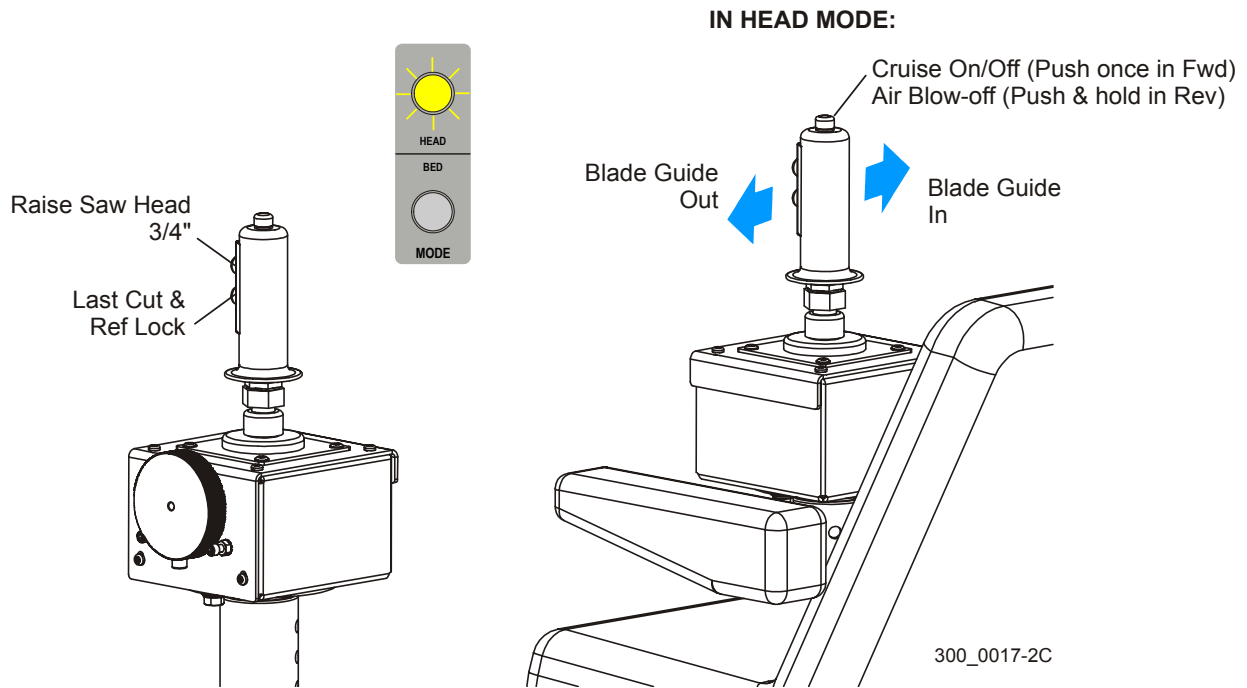

FIG. 4-4

4 Operation

Joystick Control Overview

See Figure 4-5. In BED mode, the joysticks control the log handling functions. Push the top button on the left joystick to change to bed mode. Push the right joystick forward to lower the log loader, pull it back to raise the log loader. Push the right joystick right to raise the log turner and side supports. Push it to the left to lower the turner and side supports.

The left joystick controls the log clamp in BED mode. Push it right to move the clamp in toward the log, left to move the clamp away from the log. Push the left joystick forward to lower the clamp and pull it back to raise the clamp.

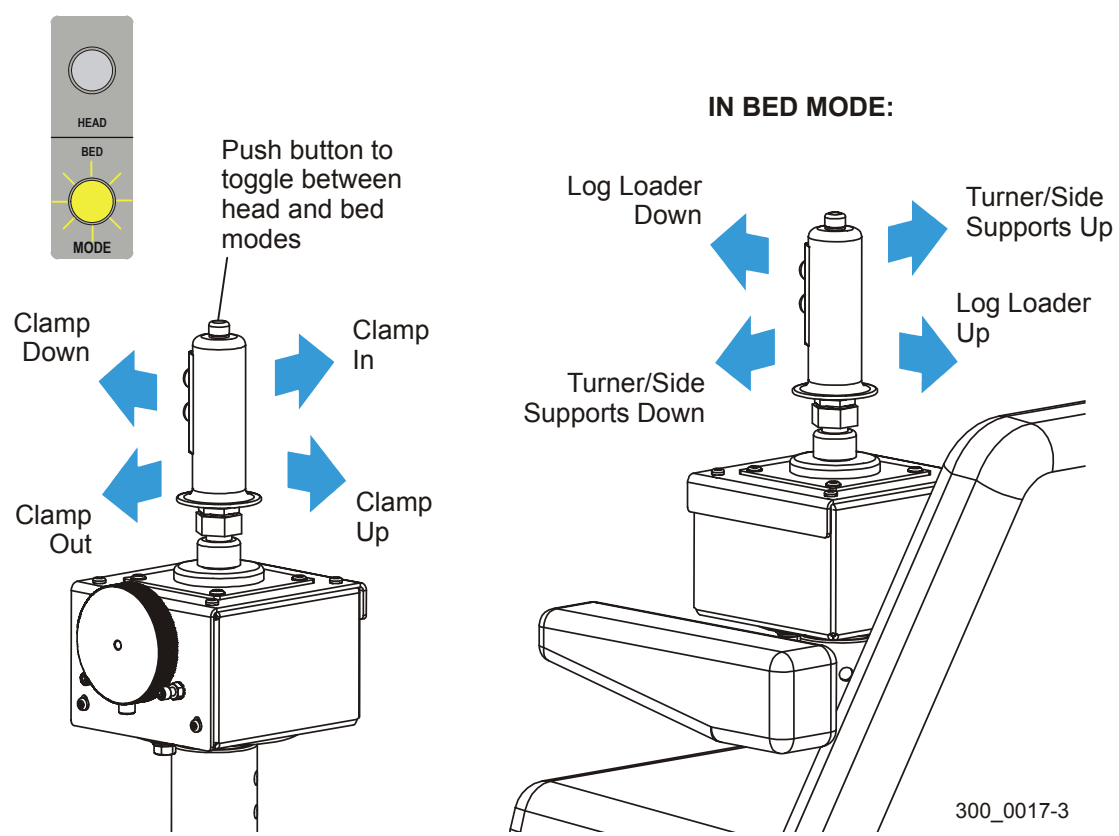

FIG. 4-5

See Figure 4-6. Push the top side button on the left joystick to rotate the turner chain forward. Push the bottom side button to reverse the turner chain.

To operate all the bed rollers, push and hold the top button of the right joystick. Push the right joystick forward to lower all the rollers, back to raise all the rollers. To operate just the front or rear roller, push and hold the top or bottom side button to select the front or rear roller. Push the right joystick forward to lower the selected roller, back to raise the selected roller. **Push the right joystick left or right to turn the power roller.**

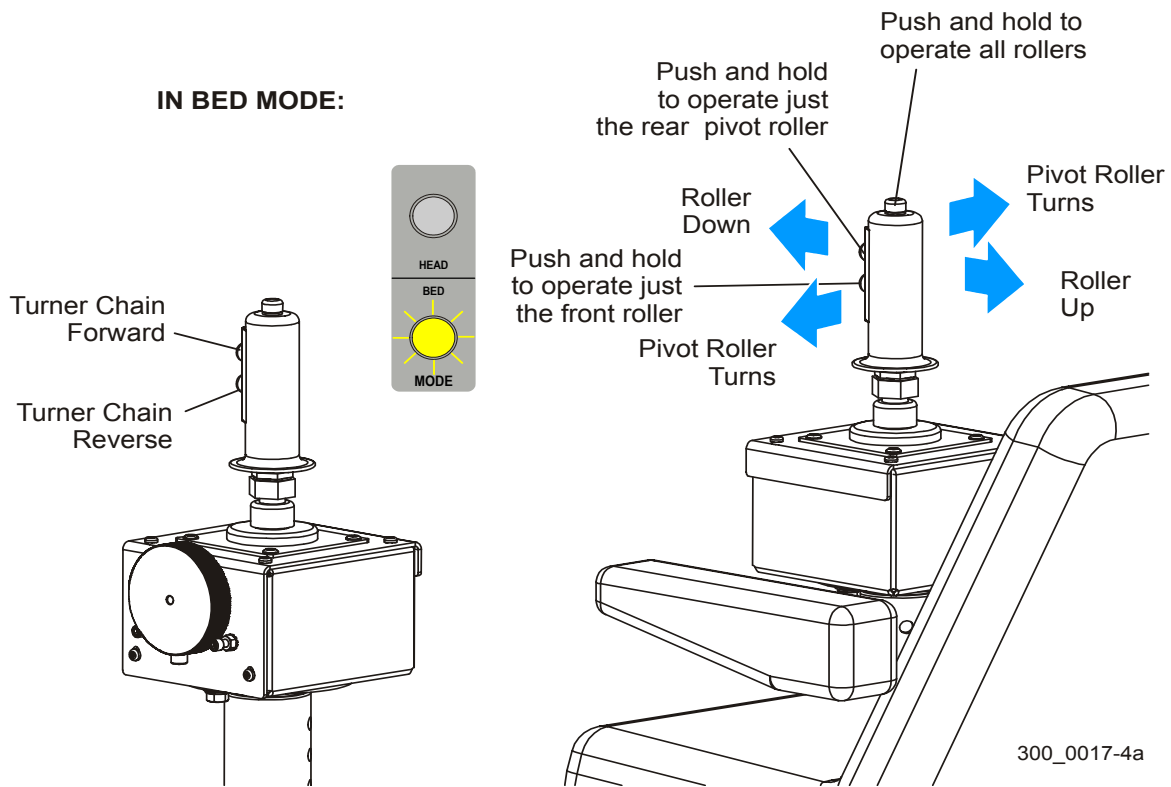

FIG. 4-6

See **Figure 4-7**. To operate the first pull-down clamp (first from the operation station side), push and hold all side buttons of the right and left joysticks. Push the right joystick forward to lower the first pull-down clamp, pull it back to raise the clamp. Push the right joystick right to move the clamp in, push it to the left to move the clamp out.

FIRST PULL-DOWN CLAMP

IN BED MODE:

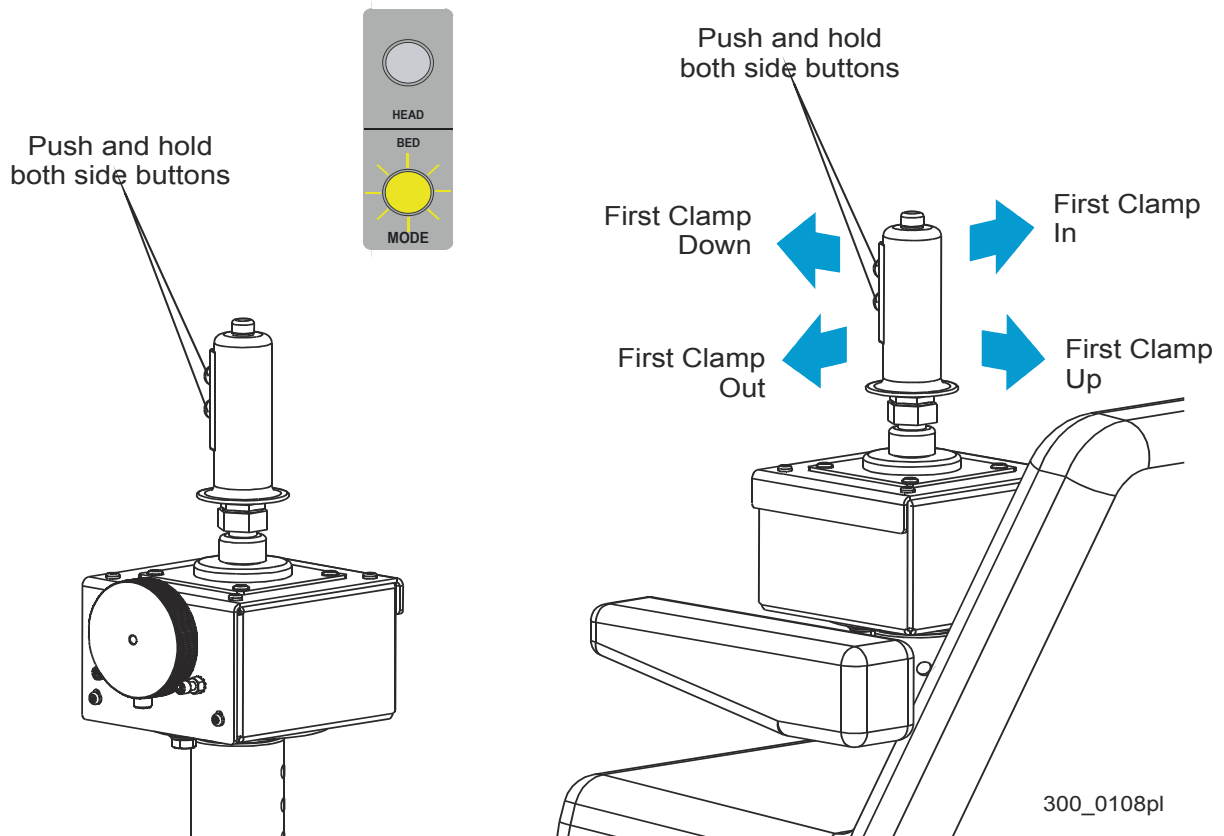

FIG. 4-7

See **Figure 4-8**. To operate the second pull-down clamp (second from the operation station side), push and hold both side buttons of the right joystick. Push the right joystick forward to lower the second pull-down clamp, pull it back to raise the clamp. Push the right joystick right to move the clamp in, push it to the left to move the clamp out.

SECOND PULL-DOWN CLAMP

IN BED MODE:

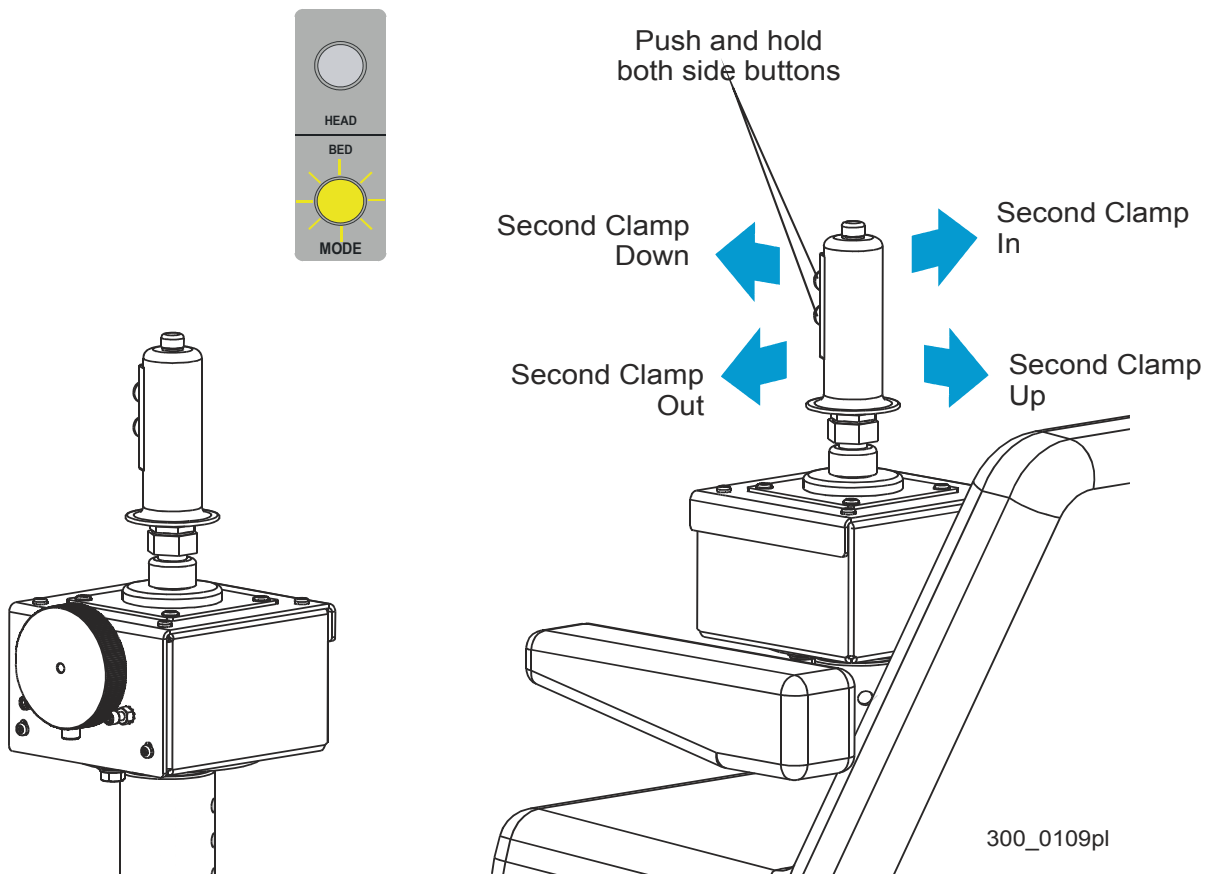

FIG. 4-8

See **Figure 4-9**. To operate the third pull-down clamp (third from the operation station side), push and hold both side buttons of the left joystick. Push the left joystick forward to lower the third pull-down clamp, pull it back to raise the clamp. Push the left joystick right to move the clamp in, push it to the left to move the clamp out.

THIRD PULL-DOWN CLAMP

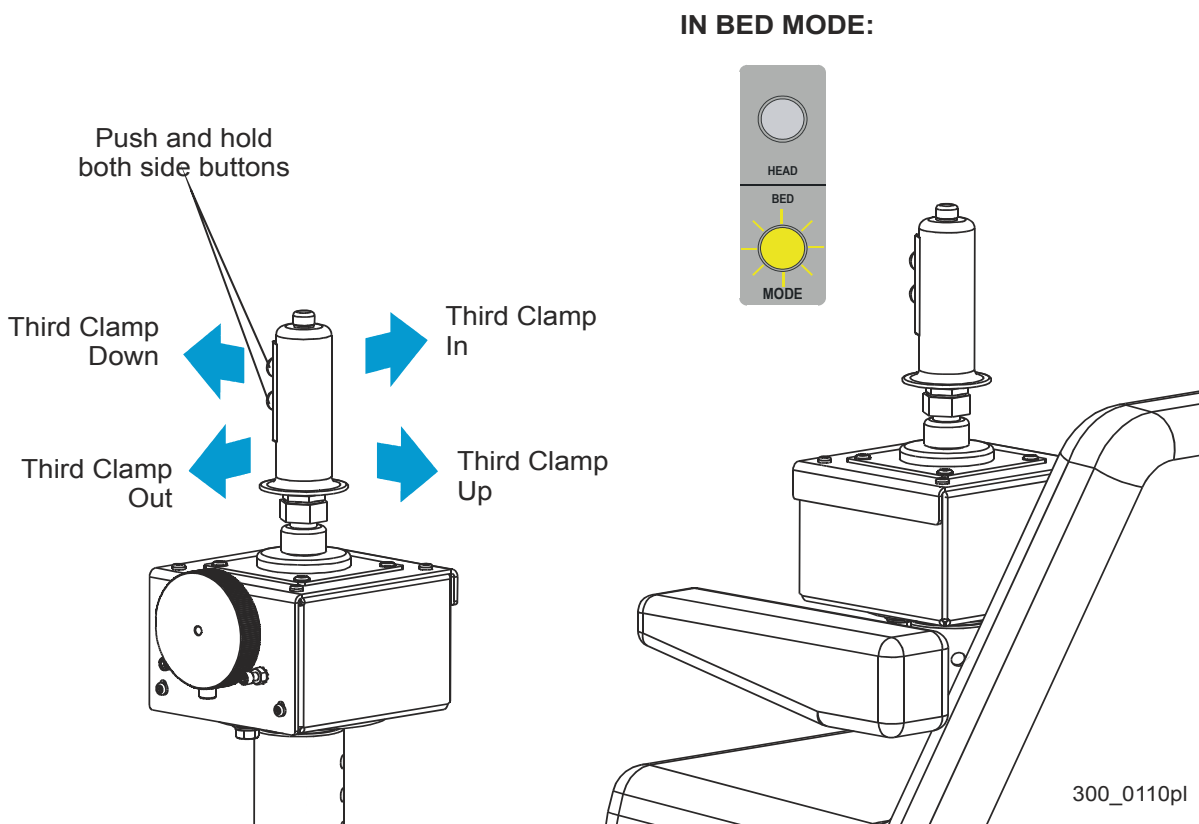

FIG. 4-9

4.4 Cruise Control

The cruise control feature of the LT300 allows the operator to let the machine choose the maximum cutting speed based on the amount of horsepower required by the blade motor. This feature is especially helpful for new operators who are not familiar with the cutting speeds of the LT300.

Cruise control should only be used when the logs being cut allow for consistent cutting speeds. Avoid using cruise control when sawing various size logs, logs with excessive knots, or logs that are tapered from one end to the other. Cruise control should not be engaged when sawing through the outer (cadmium) layer or rotten portions of wood, frozen timber, or difficult to saw species.

The Max HP and Max PF setting are used together to control the function of the cruise control. These settings are adjusted by moving the selector switch on the front of the control to the desired function and using the up/down arrows to adjust each value.

The Max HP setting represents the target horsepower of the blade motor the cruise control will attempt to maintain. As conditions such as the width of cut, denseness of the wood or condition of the blade change, the cruise control will adjust the power feed speed to maintain the Max HP that you select. To determine where to set the Max HP, observe the horsepower value on the display while making a straight, clean cut controlling the power feed manually. Use this value minus 5 to set the Max HP. You can adjust this value once you make a few cuts using the cruise control.

Example: You have trimmed a typical log to a square cant. As you manually use the power feed to saw the cant into boards as fast as you can while maintaining a straight cut, you observe the horsepower value displayed on the control. If the maximum value during the cut is 55, set the cruise control Max HP value to 50 (55 - 5).

The Max HP value can be adjusted to a minimum of 10 and a maximum of 60. The Max HP value cannot be adjusted while cruise control is engaged. Any changes to the Max HP value will not take effect until cruise control is turned off and back on again.

4.5 Programming The Control

Several features of the control can be adjusted by the operator.

4.5.1 Board Thickness

The six Board Thickness buttons control the distance the saw head drops for each cut. To display the current Board Thickness settings for each button, push the Start button. Push the Cant Size #1 button to enter pattern mode. Push the Board Thickness #1 button. The value for the Board Thickness #1 button will appear on the display (top value of the two shown). Push the other Board Thickness buttons to display their values.

See Figure 4-10.

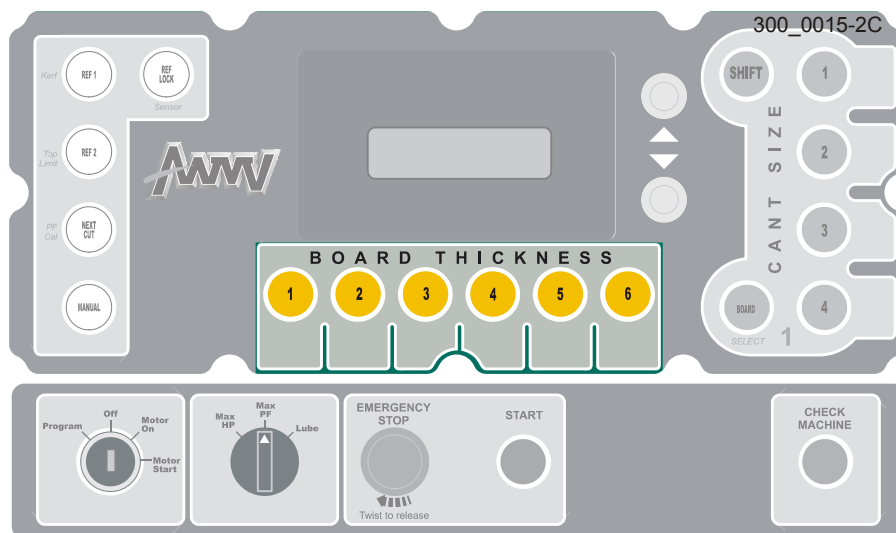

FIG. 4-10

To reprogram any Board Thickness button value, turn the key switch to the Program position. Push the Board Thickness button you wish to reprogram. Use the Up and Down buttons to adjust the value as desired. Push any Board Thickness button to enter the new value. Repeat this procedure for other Board Thickness button values you want to reprogram. Use a dry-erase marker to label each button as a quick reference for the operator.

4.5.2 Cant Size

The four Cant Size buttons are used in conjunction with the Board Thickness buttons in pattern mode to control the size of the cant leftover after boards are sawn from the log. To display the current Cant Size settings for each button, push the Start button. Push the Cant Size #1 button to enter pattern mode. Push the Cant Size #1 button again. The value for the Cant Size #1 button will appear on the display (bottom value of the two shown). Push the other Cant Size buttons to display their values.

See Figure 4-11.

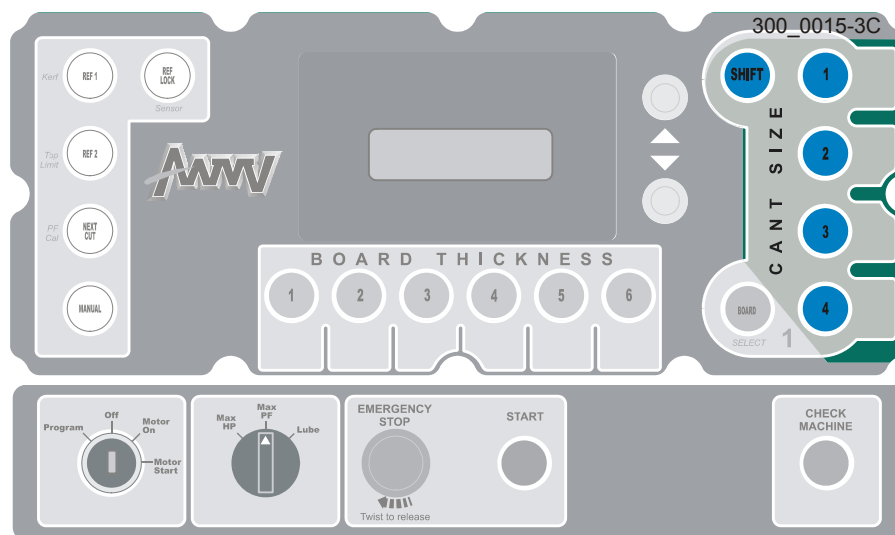

FIG. 4-11

To reprogram any Cant Size button value, turn the key switch to the Program position. Push the Cant Size button you wish to reprogram. Use the Up and Down buttons to adjust the value as desired. Push any Cant Size button to enter the new value. Repeat this procedure for other Cant Size button values you want to reprogram. Use a dry-erase marker to label each button as a quick reference for the operator.

4

Operation

Max HP, Max PF & Lube

4.5.3 Max HP, Max PF & Lube

These settings are controlled with the selector switch at the front of the control box and can be adjusted during the sawing operation.

See Figure 4-12.

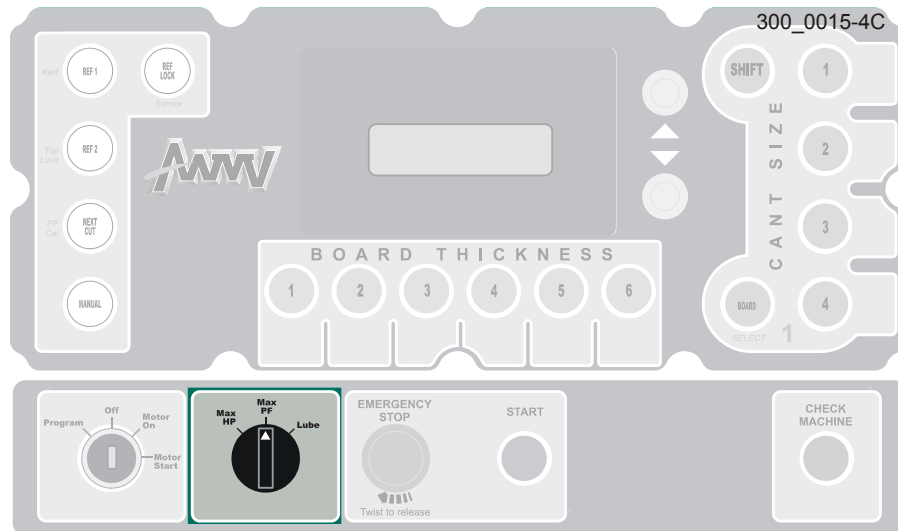

FIG. 4-12

The **Max HP** setting allows the operator to determine the maximum horsepower delivered from the blade motor. To adjust the Max HP value, turn the selector switch to Max HP and use the Up or Down buttons until the desired value is shown on the display.

The **Max PF** setting controls the maximum speed the carriage moves in the cutting direction. To adjust the Max PF value, turn the selector switch to Max PF and use the Up or Down buttons until the desired value is shown on the display.

NOTE: The Max HP and Max PF settings are used together to control the function of the cruise control feature. [See Section 4.4](#) for details.

The **Lube** setting controls the amount of lubricant applied to the blade while sawing. Some types of wood require more or less lubrication to prevent sap buildup on the blade. To adjust the Lube setting, turn the selector switch to Lube and use the Up or Down buttons to adjust the setting as desired.

4.5.4 Calibration

The Calibration setting is used to synchronize the control with the transducer sensor so the control displays the blade position accurately. The setting only needs to be changed if the CPU module or transducer sensor is replaced. To view the Calibration setting, turn the key switch to the Program position and push the Ref Lock button. To change the value, use the Up or Down buttons. **NOTE:** The Calibration value is recorded on the transducer sensor housing located at the top of the saw head mast.

4.5.5 Upper Saw Head Travel Limit

This option is available if the area where the sawmill is installed does not have enough height clearance to allow the saw head to travel to the top of the mast. To set the Upper Saw Head Travel Limit, first position the saw head at the height where you want it to automatically stop. Turn the key to the Program position and push the Ref 2 button. Push the Select button to set the limit at the current saw head position.

4.5.6 Other Settings

Other settings can be adjusted to fine tune the control to your specific operating conditions. To display the menu for these settings, turn the key switch to the Program position and push the Manual button. Use the Up or Down buttons to scroll through the menu. To adjust any of the menu values, push the Select button and use the Up or Down buttons to adjust the value. Push the Select button to enter the new value and return to the scrolling menu.

The **Autoup Height** setting is used to control the distance the blade moves up after each cut. The default value is 12/32 (3/8"). This setting can be adjusted as necessary.

The **Head Home Position** provides a reference position that can be used to automatically move the saw head to a specific location. The default value is 21". To move the blade to the Head Home Position, push and hold the Manual button and push the Last Cut button. This setting can be adjusted if you prefer a different "home" position for the saw head.

The **Max HP Limit** setting allows the operator to determine the maximum horsepower delivered from the blade motor. The default value is 75. This setting can also be adjusted with the selector switch ([See Section 4.5.3](#)).

The **PF A to D** and **PF Range** settings show values useful in troubleshooting power feed errors by a qualified technician. These values should not be adjusted by the operator.

The **X64 Drive Selection** setting indicates the type of AC drive used in the electrical system and is provided for diagnostic purposes only.

4.6 Starting The Machine



DANGER! Make sure all guards and covers are in place and secured before operating the sawmill. Failure to do so may result in serious injury. Be sure the blade housing and pulley covers are in place and secure.

DANGER! Always be sure all persons are out of the path of the blade before starting the motor. Failure to do so will result in serious injury.



WARNING! Always wear eye, ear, respiration, and foot protection when operating the sawmill. Failure to do so may result in serious injury.

1. If necessary, release the EMERGENCY STOP button by turning it clockwise until it pops out.

See Figure 4-13.

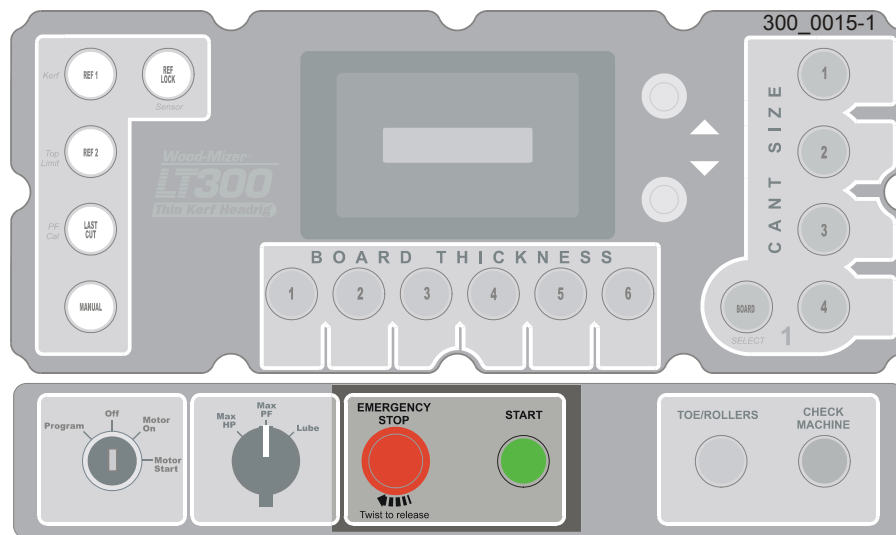





FIG. 4-13

2. To turn the sawmill power on, push the green START button on the control box.

4.7 Installing A Blade

 **DANGER!** Always shut off the sawmill and wait until the blade wheels have come to a complete stop before changing the blade. Failure to do so will result in serious injury.

 **WARNING!** Always turn the key switch to OFF and remove the key before changing the blade. Failure to do so may result in serious injury.

 **WARNING!** Always wear gloves and eye protection when handling bandsaw blades. Changing blades is safest when done by one person! Keep all other persons away from area when coiling, carrying or changing a blade. Failure to do so may result in serious injury.

 **WARNING!** DO NOT use blades with stress cracks. Blades with stress cracks can shatter causing bodily injury and/or machine damage.

1. At the operator station control box, turn the key switch to OFF and remove the key.
2. At the saw head distribution box, push the BLADE TENSION button in. This will release the tension on the existing blade (if applicable).
3. Unscrew and power the cover lock handles and open the blade housing covers.

See Figure 4-14.

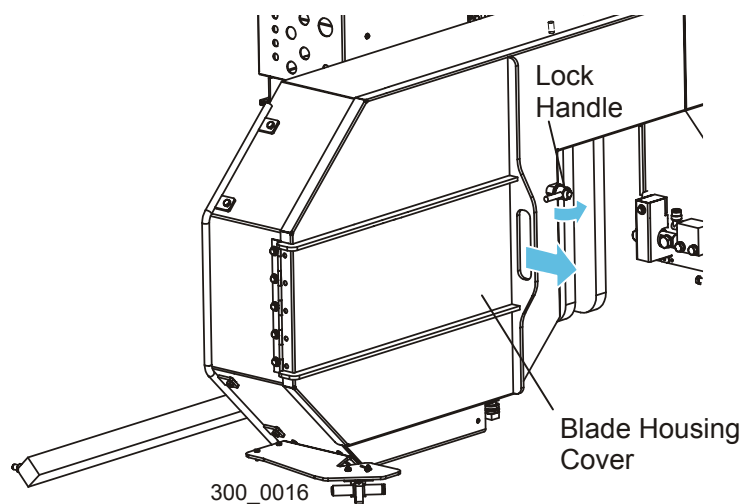

FIG. 4-14

4

Operation

Installing A Blade

4. Remove the blade if necessary.
5. Install the blade around both blade wheels and between the blade guides. Make sure the teeth are pointing the correct direction. The teeth on the portion of the blade between the blade guides should be pointing toward the motor side of the sawmill.

See Figure 4-15. Position the blade on the wheels so the gullet is even with the front edge of the wheel (+1/16", -0).

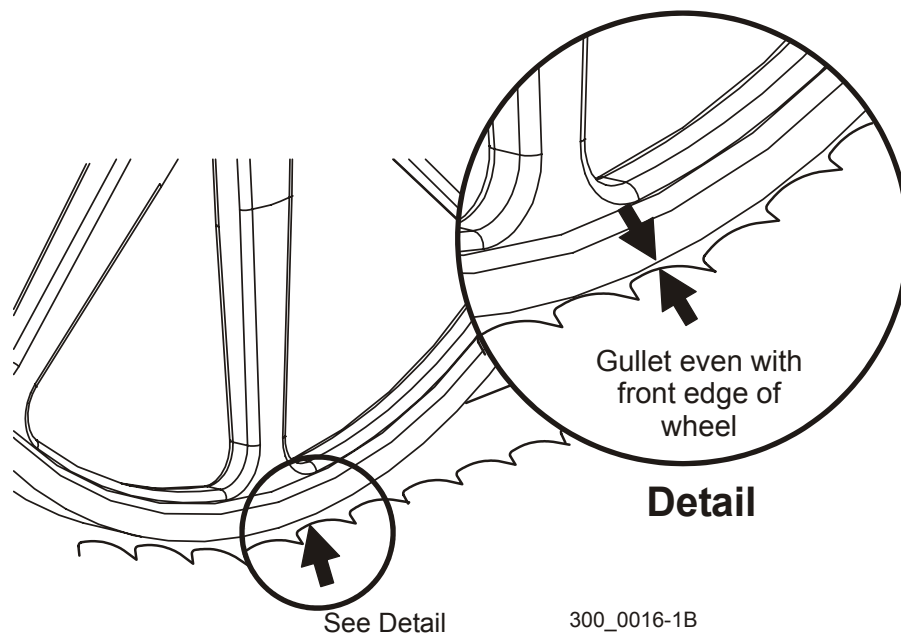

FIG. 4-15

6. Pull the BLADE TENSION button. The TENSION PRESSURE gauge should read 60 psi. To adjust the blade tension pressure, use the TENSION REGULATOR knob. Push the BLADE TENSION button to release the blade tension. Turn the TENSION REGULATOR knob counterclockwise to reduce blade tension, clockwise to increase blade tension. Pull the BLADE TENSION button to retension the blade.
7. Close the blade housing covers, secure with the lock handles and make sure all persons are clear of the saw head.
8. Insert the key and turn the key switch to the MOTOR START position and release, leaving the key switch in the MOTOR ON position. Let the motor spin the blade for a few seconds, turn the key switch to OFF and remove the key.



WARNING! Do not spin the blade wheels by hand. Spinning the blade wheels by hand may result in serious injury.

9. Open the blade housing covers and recheck the position of the blade on the blade wheels. Make sure the blade has maintained the proper position on the blade wheels as described above. If adjustment is needed, push the BLADE TENSION button to release the blade tension and adjust the wheel as described below.

See Figure 4-16. To adjust the position of the blade on the blade wheels, loosen the jam nuts on the side adjustment bolts located at the end of the blade wheel shaft housing.

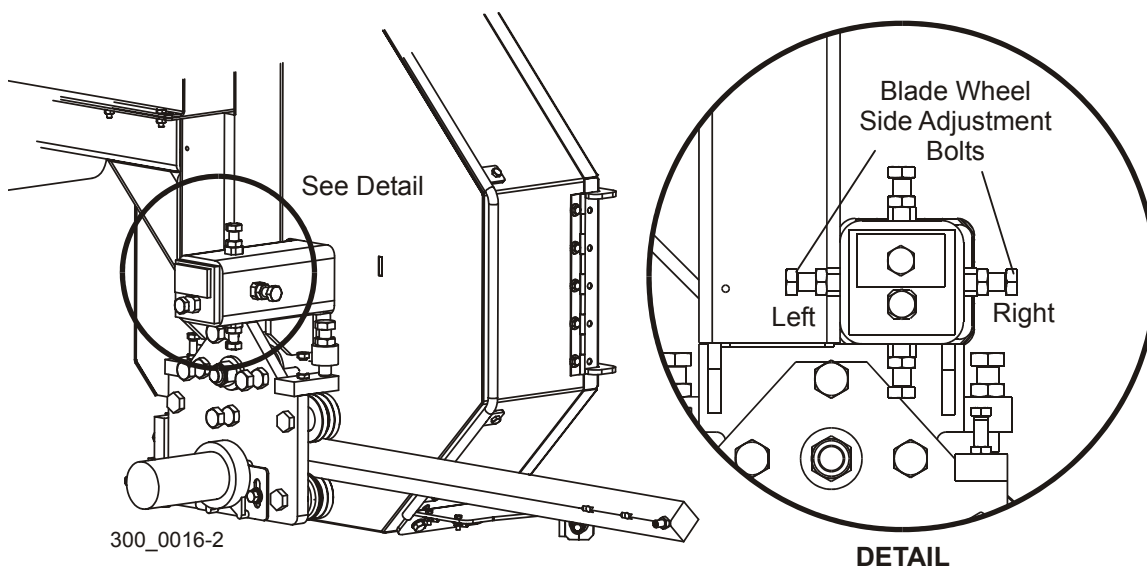



FIG. 4-16

To move the blade out on the blade wheel, loosen the right bolt and tighten the left bolt. To move the blade in on the blade wheel, loosen the left bolt and tighten the right bolt.

NOTE: Slight adjustments of the side bolts on the outer blade wheel are usually all that is necessary to track the blade properly. [See Section 7.2](#) for complete blade wheel alignment instructions.

10. Tighten the side adjustment bolt jam nuts, close the blade housing covers, retension the blade and spin the blade again. Repeat this procedure until the blade tracks on the blade wheels properly.

4.8 Loading, Turning And Clamping Logs

 **DANGER!** Keep all persons out of the path of moving equipment and logs when operating sawmill or loading and turning logs. Failure to do so will result in serious injury.

 **CAUTION!** Before loading a log, be sure the cutting head is moved far enough back so the log does not hit it. Failure to do so may result in machine damage.

 **CAUTION!** Be sure the log clamp, turning arm and rollers are adjusted out of the path of the log before loading a log onto the bed. Failure to do so may result in machine damage or cause misalignment.

1. Move the saw head to the rear of the sawmill before loading a log. Push the top button on the left joystick to toggle the MODE function to HEAD, if necessary. Push the top side button on the right joystick to raise the saw head to clear any obstructions and push the right joystick forward to move the saw head to the rear of the sawmill.

See Figure 4-17.

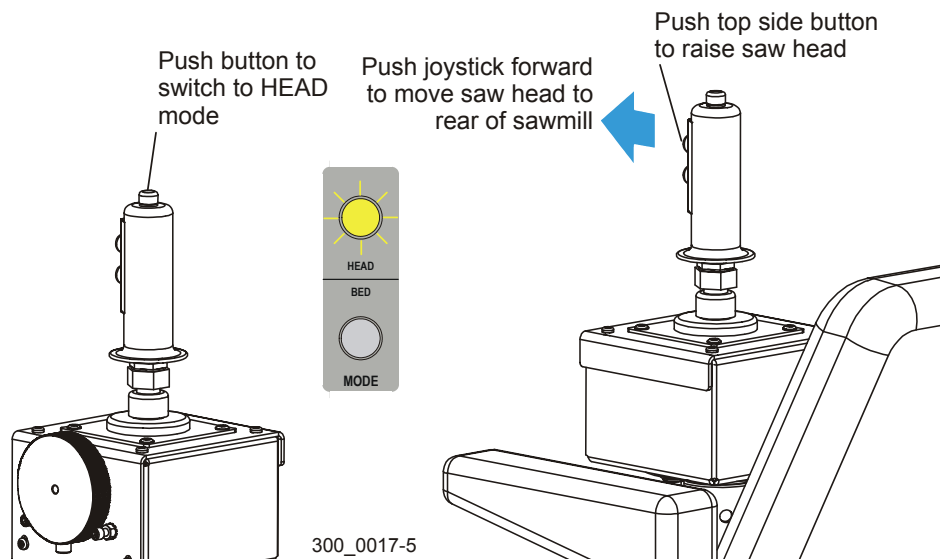

FIG. 4-17

2. Push the top button on the left joystick to toggle the MODE function to BED. Push the right joystick to the right to raise the side supports. Stop when the side supports are fully vertical, before the turner starts up.

See Figure 4-18.

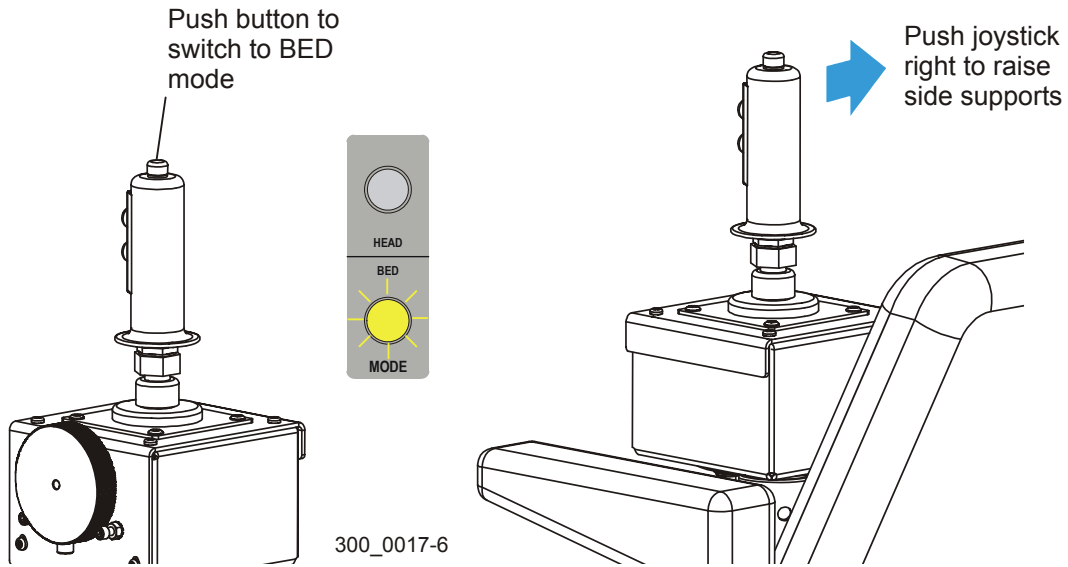

FIG. 4-18

4

Operation

Loading, Turning And Clamping Logs

3. If necessary, lower the clamp and rollers so they are below bed level. Push the left joystick forward to lower the clamp. To lower the pull-down clamps, [See Section 4.3](#). Push and hold the top button on the right joystick. Push the right joystick forward to lower the rollers.

See Figure 4-19.

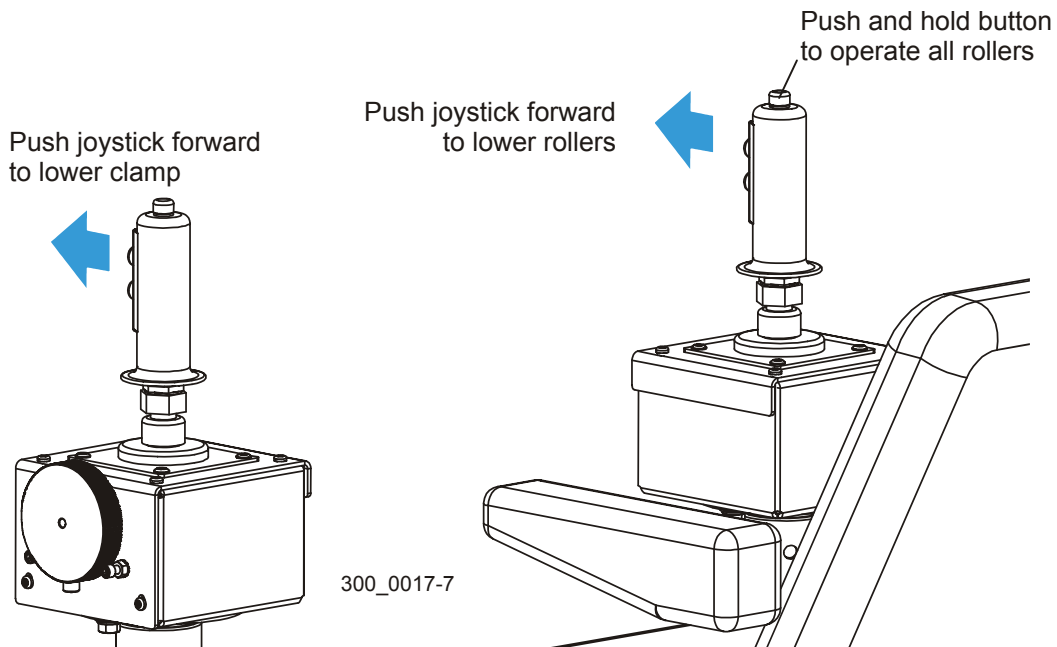

FIG. 4-19

4. Push the right joystick forward to lower the log loader, if necessary.
5. Use cant hooks or loading equipment to move the log to the foot of the loading arms. Roll the log onto the loader so that it is approximately centered with the sawmill bed. The log turner will operate much easier if the log is centered on the sawmill bed. **To center the log on the sawmill bed use the power, rear roller.**

See Figure 4-20.

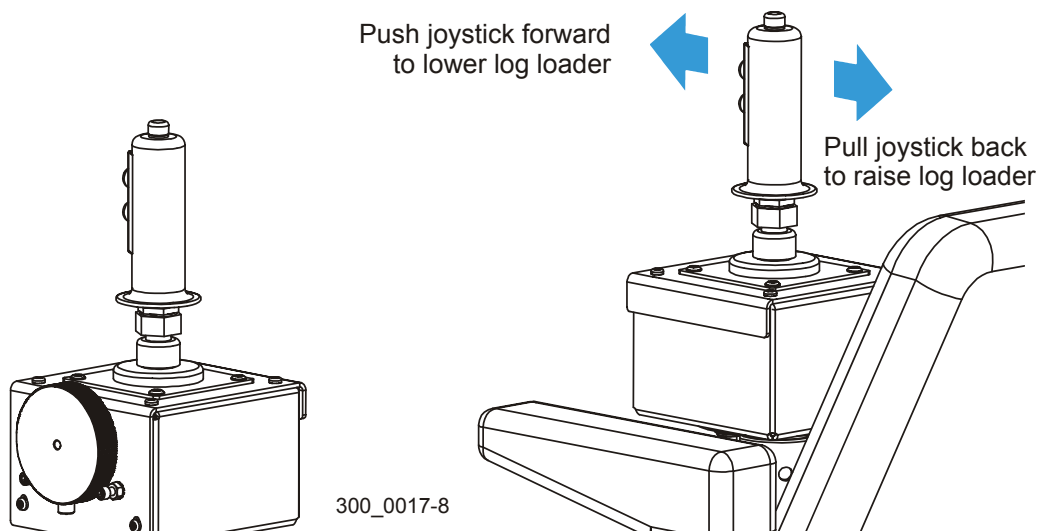

FIG. 4-20

6. Pull the right joystick back to raise the log loader. Raise the loader until the log rolls onto the mill bed.

DANGER! Keep all persons out of the path of moving equipment and logs when operating sawmill or loading and turning logs. Failure to do so will result in serious injury.

7. Push the right joystick forward to lower the loading arm. Leave the loading arm about halfway up while squaring the log. This will stop the log from rolling off the side of the sawmill.

WARNING! Always leave loading arm halfway up while log is on sawmill bed. Failure to do so may result in serious injury or death.

NOTE: Logs also may be loaded onto the mill with a tractor or other equipment specifically designed for that purpose.

4

Operation

Loading, Turning And Clamping Logs

8. Pull the left joystick back to raise the clamp to prevent the log from rolling off the bed.
9. Push the right joystick to the right to raise the log turner until it contacts the log. Hold the joystick to the right so the turner maintains contact with the log. Push the top and bottom side buttons on the left joystick to rotate the turner chain until the log is positioned as desired for the first cut.

See Figure 4-21.

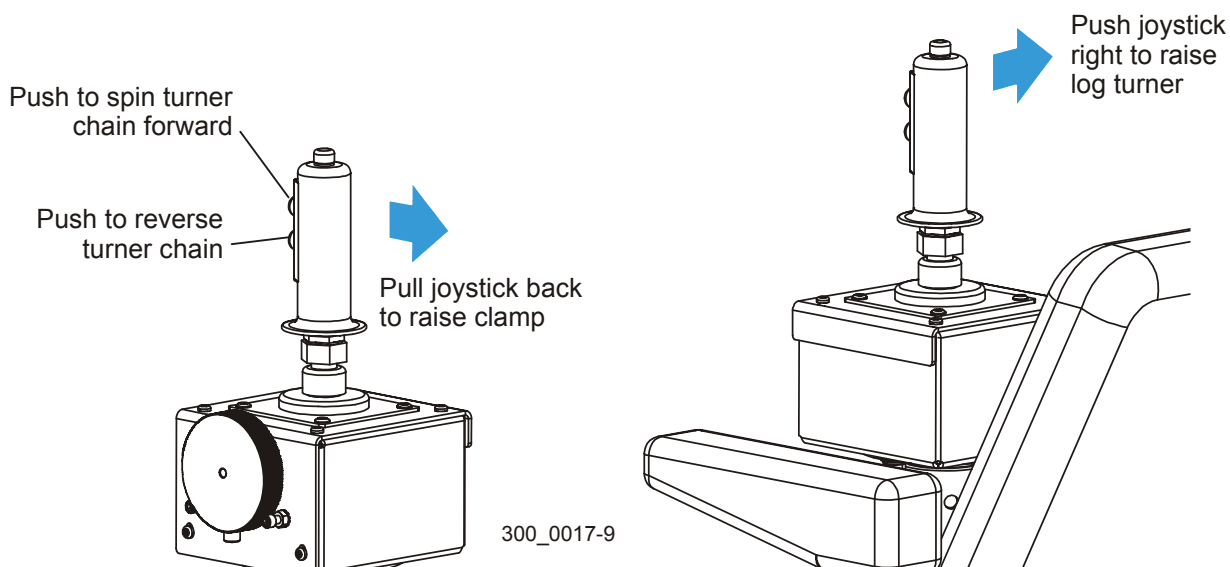

FIG. 4-21

10. Push the left joystick to the right to move the clamp toward the log. Before the clamp contacts the log, push or pull the left joystick to raise or lower the clamp as desired. Push the right joystick to the left to lower the turner. Continue until the side supports are lowered to the desired position.
11. For instructions for using the pull-down clamps, [See Section 4.3](#).

12. Use the front or rear roller to raise the small end of a tapered log until the heart of the log is parallel to the bed. Push and hold the **bottom** side button on the right joystick to select the front roller, or the **top** side button to select the rear roller. Push the right joystick forward to **lower** the selected roller, back to **raise** the selected roller.

See Figure 4-22.

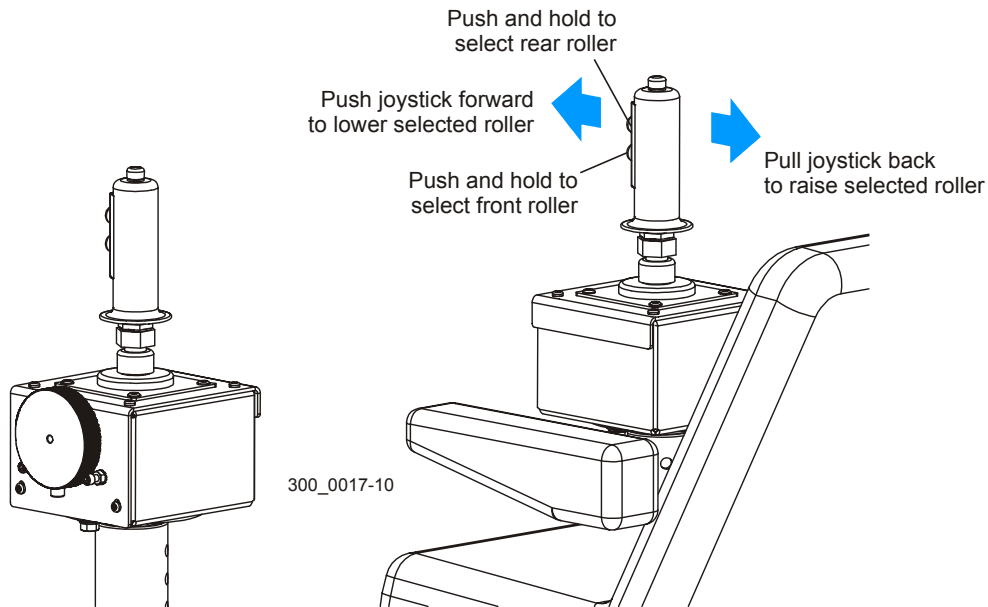

FIG. 4-22

13. Push the left joystick to the right until the log is clamped firmly against the side supports.
14. Push the top button on the left joystick to switch to HEAD mode to begin sawing the log.

4.9 Setworks Overview

See Figure 4-23. There are three sawing methods that can be used to saw logs:

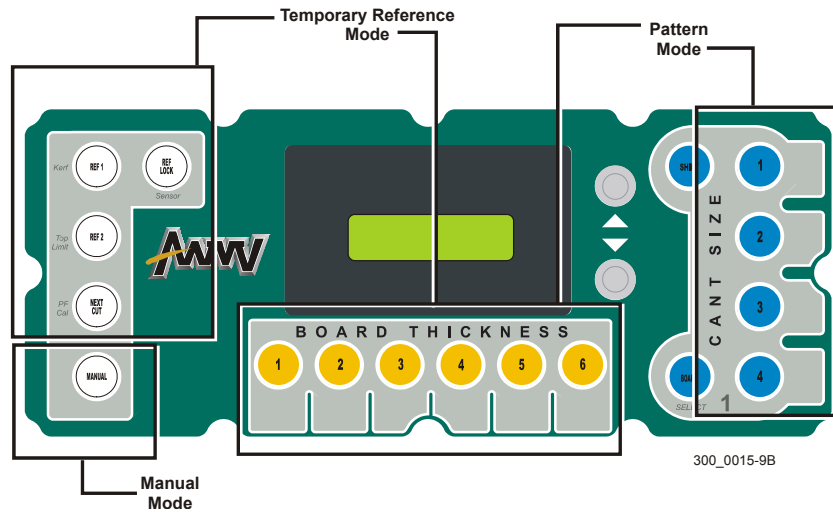

FIG. 4-23



MANUAL mode: the joystick controls will move the saw head up or down to any position until the joystick control is released.



TEMPORARY REFERENCE mode: the control references a temporary position of the blade (not the bed) and automatically moves the blade the distance determined by the selected BOARD THICKNESS button. Mostly used when sawing for grade where the outer perimeter of the log contains the highest-quality boards.



PATTERN mode: the control references the position of the blade from the bed rails determined by the selected CANT SIZE button. The control will automatically move the blade the distance determined by selected BOARD THICKNESS button starting at the distance from the bed determined by the selected CANT SIZE button. Typically used when dimensional sawing or finishing a hardwood log to a finish sized cant.

4.9.1 Temporary Reference Mode

See Figure 4-24. Temporary Reference Mode utilizes the group of white buttons at the left of the control. This mode allows the operator to temporarily set any position of the blade (not the bed) as a reference for subsequent cuts. Temporary Reference Mode is best used when sawing for grade where the outer perimeter of the log contains the highest-quality boards.



FIG. 4-24

Use the white buttons in combination with the yellow BOARD THICKNESS buttons when sawing in Temporary Reference Mode:

1. When you first turn on the machine, the control defaults to Manual Mode (the white MANUAL button will be on). To enter Temporary Reference Mode, push the REF 1 button. The saw head will still operate as if in Manual Mode until the reference position is locked by using the REF LOCK button as described later.
2. With a new log loaded and clamped in position on the bed, push the REF 1 button. The MANUAL light will go out. Networks will still operate in manual mode until the reference position is locked by the operator.
3. When REF 1 is activated, one of the yellow BOARD THICKNESS buttons will illuminate. By default, the last thickness used in REF 1 will be selected. Choose another BOARD THICKNESS button as desired. [See Section 4.5.1](#) for instructions to program the BOARD THICKNESS buttons.
4. Raise or lower the saw head using the joystick Up/Down buttons until the blade is positioned where you want to make the first cut.



4

Operation

Temporary Reference Mode

5. Push the REF LOCK and NEXT CUT buttons.

SHORTCUT: Press the bottom-left joystick button to enable REF LOCK and NEXT CUT simultaneously. After the reference is locked, the joystick button will toggle NEXT CUT on and off.

See Figure 4-25. With the position of the blade now stored and locked as REF 1, when you push the Up or Down joystick button, networks will move the blade up or down the distance determined by the selected BOARD THICKNESS button. With NEXT CUT enabled, Setworks will automatically position for the next cut below the last set position of the blade.

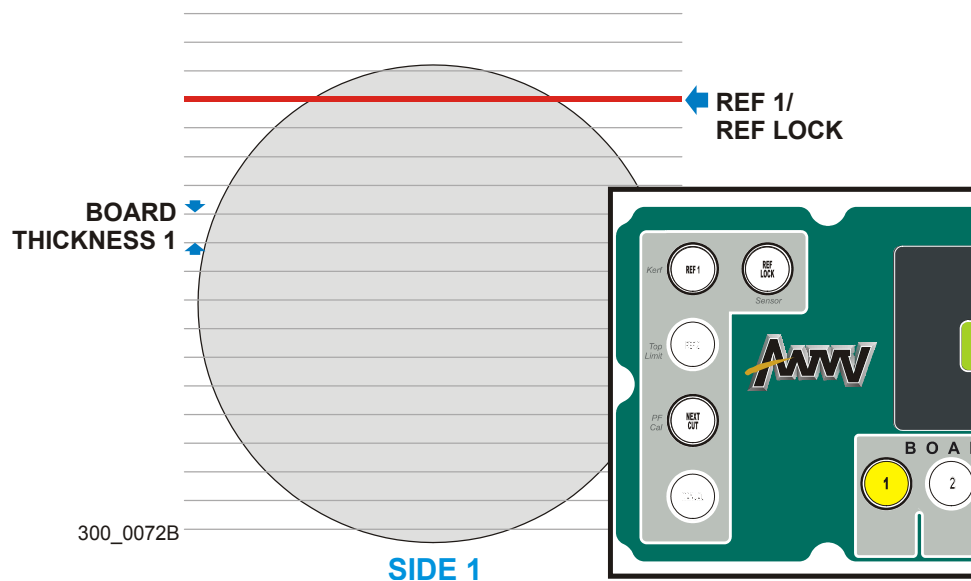

FIG. 4-25

6. After making the first cut, raise and return the saw head. There are two methods of raising the saw head that can be used when sawing in Temporary Reference Mode:

Auto Bump-up: Use the top side button on the left joystick to slightly raise the blade and drag the board/slab off when you return the saw head. Auto Bump-up does not affect the stored position of the blade during the last cut.

Saw Head Up: If the slab is too small to drag back, use the top side button on the right joystick to raise the blade over the slab. Hold the button until the blade is above the slab then quickly press the button a second time. This will abort the Setworks control before it reaches the next programmed target, preventing it from replacing the stored position of the blade during the last cut.

7. Return the saw head. Push the joystick Down button momentarily and setworks will automatically position the blade for the next cut.
8. Make cuts as desired until you are ready to turn the log.
9. Return the saw head and push the REF LOCK button to disable the lock.

NOTE: Since the log was resting on a round, REF 1 is a throw-away reference. You don't need to keep the REF 1 value until the log is resting on a flat.

10. Turn the log. Raise or lower the saw head until the blade is positioned as desired. Enable REF LOCK and NEXT CUT.

See Figure 4-26. With the position of the blade now stored and locked as REF 1, when you push the Up or Down joystick button, setworks will move the blade up or down the distance determined by the selected BOARD THICKNESS button. With NEXT CUT enabled, Setworks will automatically position for the next cut below the last set position of the blade.

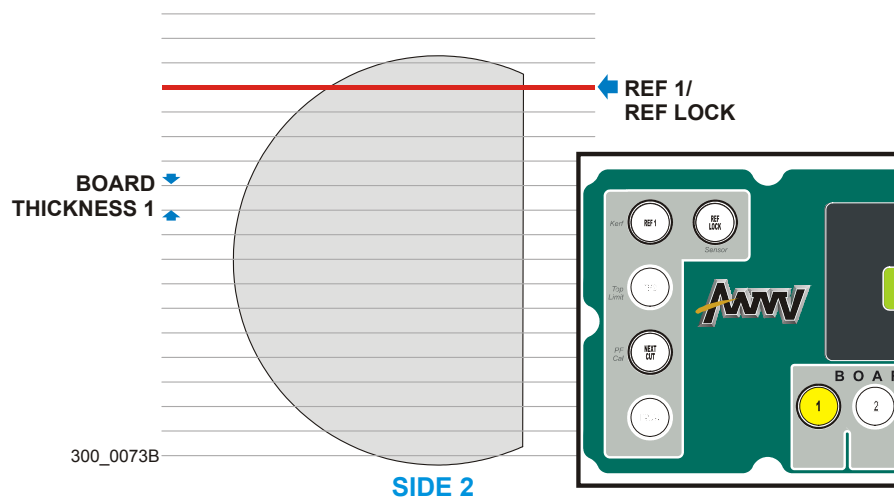

FIG. 4-26

11. Make the cut and return the saw head. Push the joystick Down button momentarily and setworks will automatically position the blade for the next cut.
12. Make cuts as desired until you are ready to turn the log.
13. Return the saw head and push the REF LOCK button to disable the lock.
14. Turn the log. Raise or lower the saw head until the blade is positioned as desired. Enable REF LOCK and NEXT CUT.



4

Operation

Temporary Reference Mode

See **Figure 4-27**. With the position of the blade now stored and locked as REF 1, when you push the Up or Down joystick button, networks will move the blade up or down the distance determined by the selected BOARD THICKNESS button. With NEXT CUT enabled, Setworks will automatically position for the next cut below the last set position of the blade. Since the log was resting on a flat, the REF 1 value should be kept and REF 2 used for the next side of the log.

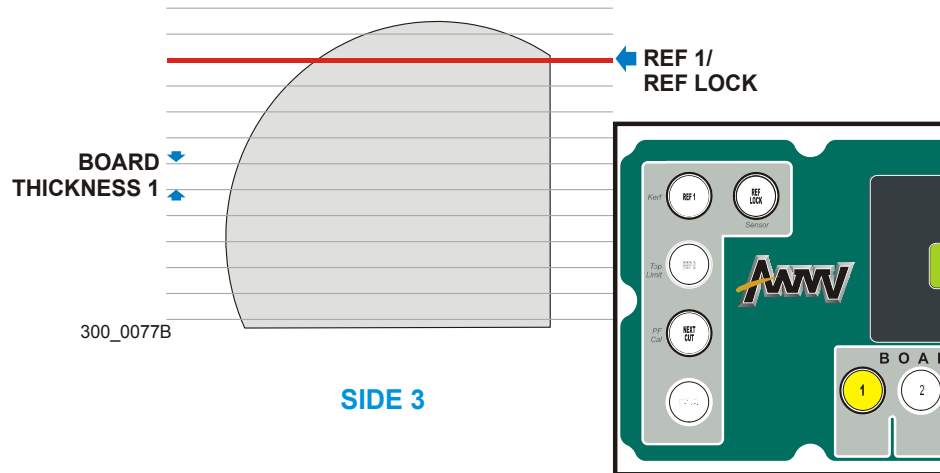

FIG. 4-27

15. Make the cut and return the saw head. Push the joystick Down button momentarily and networks will automatically position the blade for the next cut.
16. Make cuts as desired until you are ready to turn the log.
17. Return the saw head. Now that three sides of the log are flat, you can retain REF 1 to cut sides 1 and 3. DO NOT push the REF LOCK button or you will lose the REF 1 setting. Push the REF 2 button to leave REF 1 and enable REF 2. REF 1 dimensions will remain 'locked' until you unlock it by pushing REF LOCK or MANUAL buttons.
18. Turn the log. Raise or lower the saw head until the blade is positioned as desired. Enable REF LOCK and NEXT CUT.



See Figure 4-28. With the position of the blade now stored and locked as REF 2, when you push the Up or Down joystick button, setworks will move the blade up or down the distance determined by the selected BOARD THICKNESS button. With NEXT CUT enabled, Setworks will automatically position for the next cut below the last set position of the blade.

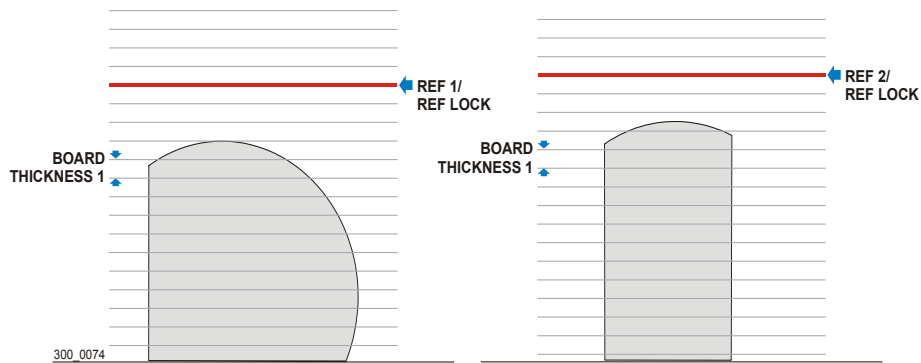

FIG. 4-28

19. Make the cut and return the saw head. Push the joystick Down button momentarily and setworks will automatically position the blade for the next cut.
20. Make cuts as desired until you are ready to turn the log. Now that all four sides of the log are flat, you can simply toggle between REF 1 and REF 2 as you turn the log.
21. Return the saw head and turn the log. Push the REF 1 button and push the joystick Down button momentarily. Setworks will position the blade for the next cut referenced from the last cut made in REF 1.

NOTE: With NEXT CUT enabled, the saw head will move to the to the next sawing position if you press the UP or DOWN joystick button. If the blade needs to move up to reach the NEXT CUT, even if you push the DOWN button, the saw head will move up.

4 Operation

Temporary Reference Mode

See **Figure 4-29**. When you push the Up or Down joystick button, networks will move the blade up or down the distance determined by the selected BOARD THICKNESS button.

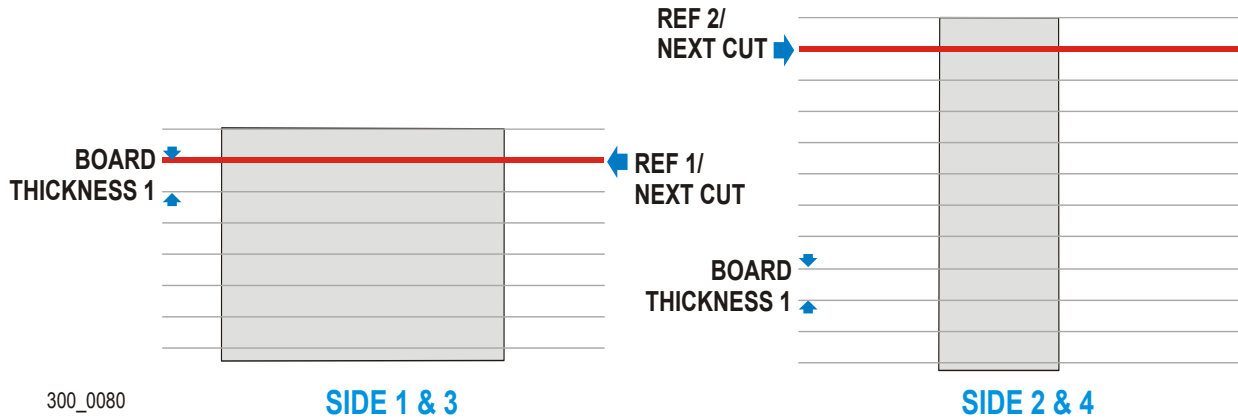

FIG. 4-29

22. Continue turning and sawing the log, using REF 1, REF 2 and NEXT CUT. You can switch BOARD THICKNESS buttons or change to Pattern Mode ([See Section 4.9.2](#)) at any time.

4.9.2 *Pattern Mode*

See Figure 4-30. Pattern Mode utilizes the blue CANT SIZE buttons at the right of the control. This mode allows the operator to position the blade referenced from the bed rails. Pattern Mode is best used when sawing dimensional lumber or finishing a cant to size when grade sawing.

The SHIFT button allows twelve settings for the four pattern buttons. Push the SHIFT button once. The SHIFT button will illuminate indicating pattern settings 5-8 are active. Push the SHIFT button a second time. The SHIFT button will flash indicating pattern settings 9-12 are active. Push the SHIFT button again to turn off and return to pattern settings 1-4.

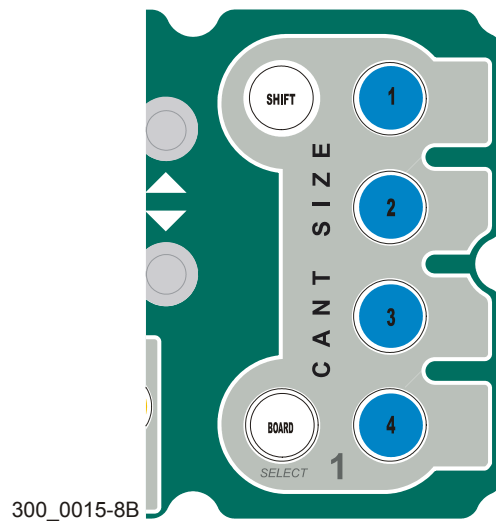

FIG. 4-30

Use the blue buttons in combination with the yellow BOARD THICKNESS buttons when sawing in Pattern Mode:

1. Use Temporary Reference Mode until at least two adjacent sides of the log are flat ([See Section 4.9.1](#)).
2. With the log resting on a flat, push the desired CANT SIZE button. Setworks is now in Pattern Mode. [See Section 4.5.2](#) for instructions to program the CANT SIZE buttons.
3. When a CANT SIZE button is activated, one of the yellow BOARD THICKNESS buttons will illuminate. By default, the last thickness used with the selected CANT SIZE setting will be selected. Choose another BOARD THICKNESS button as desired. [See Section 4.5.1](#) for instructions to program the BOARD THICKNESS buttons.
4. In Pattern Mode, setworks calculates the blade position in increments defined by the BOARD THICKNESS setting, starting at the position determined by the CANT SIZE set-

4 **Operation** *Pattern Mode*

ting.

See **Figure 4-31**. With CANT SIZE button #1 programmed for 6" and BOARD THICKNESS button #1 programmed for 1 1/4", setworks calculates the blade position as shown.

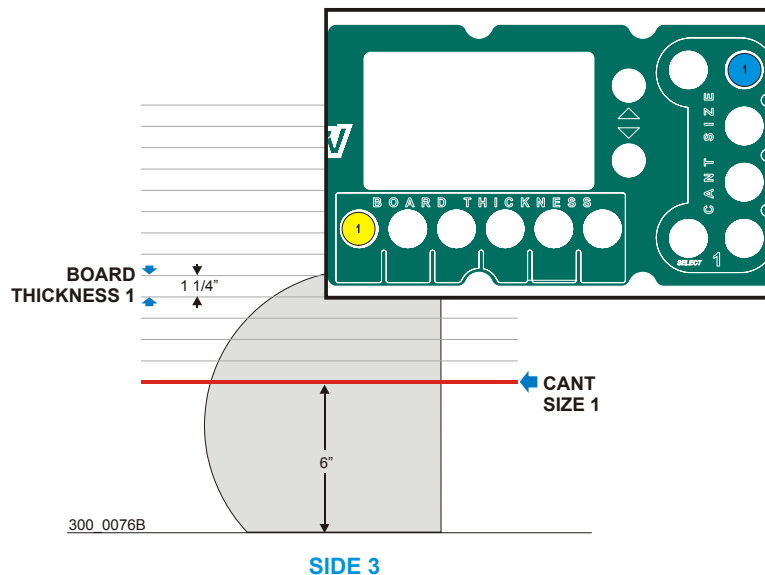

FIG. 4-31

5. Press the Up or Down joystick button momentarily to position the blade for the first cut. Push the NEXT CUT button.
6. After making the first cut, raise and return the saw head. There are two methods of raising the saw head that can be used when sawing in Pattern Mode:

Auto Bump-up: Use the top side button on the left joystick to slightly raise the blade and drag the board/slab off when you return the saw head. Auto Bump-up does not affect the stored position of the blade during the last cut.

Saw Head Up: If the slab is too small to drag back, use the top side button on the right joystick to raise the blade over the slab. Hold the button until the blade is above the slab then quickly press the button a second time. This will abort the Setworks control before it reaches the next programmed target, preventing it from replacing the stored position of the blade during the last cut.
7. Return the saw head. Push the joystick Down button momentarily and setworks will automatically position the blade for the next cut.
8. Make cuts as desired until you are ready to turn the log.
9. You can choose a different CANT SIZE setting for the second side of the log.

4 Operation

Pattern Mode

See Figure 4-32. With CANT SIZE button #2 programmed for 4" and BOARD THICKNESS button #1 programmed for 1 1/4", setworks calculates the blade position as shown.

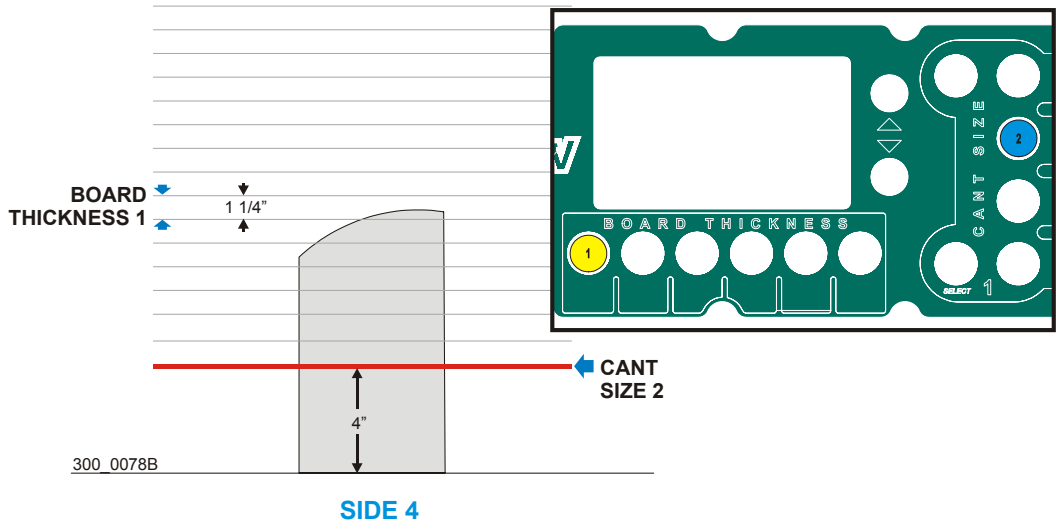

FIG. 4-32

Use the CANT SIZE and BOARD THICKNESS buttons in combination to continue sawing the rest of the log. In this example, you are left with a 4x6 cant.

See Figure 4-33. The BOARD button provides ten pre-programmed board thicknesses calculated from the bed rails. With the BOARD button enabled, Setworks will calculate the blade position using any one of the BOARD THICKNESS or CANT SIZE buttons.

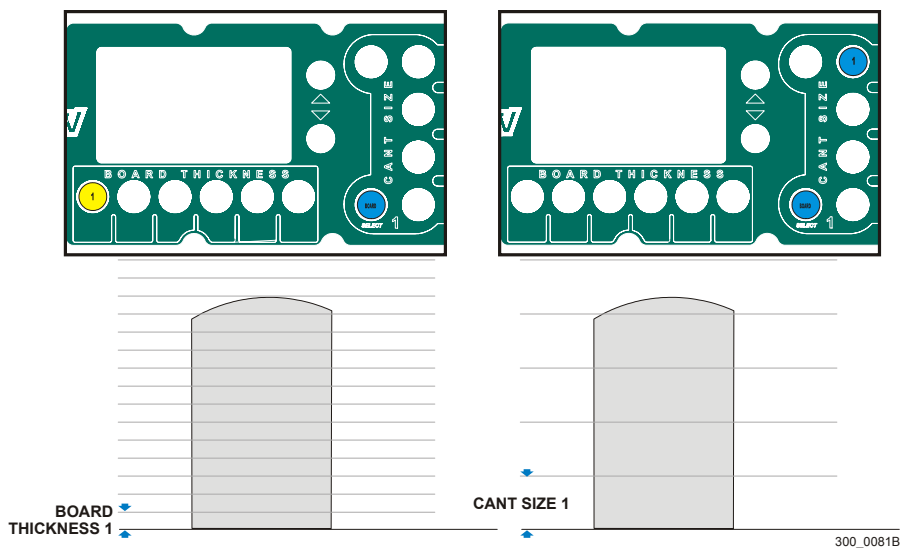

FIG. 4-33

4.10 Sawing Logs



DANGER! Keep all persons out of the path of moving equipment and logs when operating sawmill or loading and turning logs. Failure to do so will result in serious injury.

The following is a general procedure for sawing a log. See the previous sections of this manual for details concerning the operations listed.

4.10.1 Prepare the LT300 for loading a log

1. Push the START button on the control panel to turn the machine on.
2. Push the MODE button (top-left joystick) to enter HEAD MODE.
3. Push the right joystick forward to move the saw carriage to the rear of the machine. Be sure the saw head is clear of the log to be loaded.
4. Rotate the feed rate dial all the way away from you to set the feed to zero.
5. Push the MANUAL and LAST CUT buttons simultaneously to move the blade to the “home” position.
6. Push the MODE button to enter BED mode.
7. Push the right joystick to the left to raise the side supports. Release the joystick before the turner rises above the bed rails.
8. Push the left joystick to the left until the clamp is all the way out. Push the left joystick forward to lower the clamp below the bed rails.
9. Push and hold the top-right joystick button and push the right joystick forward to lower all toe rollers below the bed rails.

4.10.2 Load the log

1. If using the standard log loader, push the right joystick forward to lower the loader if necessary. Roll a log onto the loader. Pull the right joystick back to raise the loader until the log rolls onto the bed rails.

If using the optional log infeed deck, push the right joystick forward to lower the log deck until the log rolls onto the bed rails.

2. Pull the left joystick back to raise the clamp to prevent the log from rolling off the bed rails.
3. If using the standard log loader, push the right joystick forward to lower the loader halfway

down.



WARNING! Always leave loading arm halfway up while log is on sawmill bed. Failure to do so may result in serious injury or death.

If using the optional log infeed deck, pull the right joystick back to raise the log deck all the way up.

4.10.3 Turn the log

1. Push the right joystick to the right to raise the log turner until the chain engages the log. Push the left joystick side buttons to rotate the log as desired.
2. Push the right joystick to the left to lower the log turner. When the turner is all the way down, the side supports will start to go down.
3. Release the joystick when the side supports are positioned as desired. Be sure the side supports are positioned below the path of the blade.

4.10.4 Clamp the log

1. Push the left joystick forward to lower the clamp. Be sure the clamp is positioned below the path of the blade.
2. Push the left joystick to the right to move the clamp toward the log.
3. Release the left joystick when the log is clamped securely against the side supports. Double-check the clamp and side supports are positioned below the path of the blade.

4.10.5 Level the log

1. If the log is tapered on one end, use the toe rollers to lift the small end up. Move the clamp out slightly.
2. To raise the front toe rollers, press and hold the **bottom-right** joystick button and pull the right joystick back.

To raise the rear toe roller, press and hold the **top-right** joystick button and pull the right joystick back.

3. **Use power roller to position the log or cant on the sawmills bed frame.**



WARNING! Use the power roller carefully, log can be pushed on the operators station or pushed out from the sawmill bed frame. Keep all persons out of the path of moving logs or cants.

4. Reclamp the log.

4.10.6 *Saw the log*

1. Push the top-left joystick button to enter HEAD mode.
2. Turn the key switch to MOTOR START and release.
3. With the feed rate dial adjusted all the way down, pull the right joystick back. Slowly rotate the feed rate dial toward you until the blade is close to the end of the log. Release the joystick to stop the saw head. Rotate the feed rate dial away from you to return the feed rate to zero.
4. Push the top and bottom buttons on the right joystick to raise or lower the saw head until the blade is positioned for the first cut. Use the laser sight to help you determine the best location for the cut. The laser beam indicates the path of the blade down the entire log.
5. Push the right joystick left or right to move the outer blade guide close to the log.
6. Select the networks mode and push the bottom-left joystick to enable REF LOCK and/or LAST CUT.
7. Pull the right joystick back and slowly turn the feed rate dial toward you. When the blade is completely in the log, turn the feed rate dial toward you until the desired cutting speed is reached.
8. As you make the cut, watch the position of the outer blade guide and adjust in or out as necessary.
9. When the blade exits the log, increase the feed rate until the board return fingers drop down at the end of the log. Release the right joystick and turn the feed rate dial all the way down.
10. Push the top-left joystick button to raise the blade slightly.
11. Push the right joystick forward to return the saw head and remove the board/slab. Hold the top-right joystick button down as you return the saw head to blowoff sawdust from the last cut so you clearly see the grade of the wood.
12. Push the bottom-right joystick to lower the blade for the next cut or turn the log.

SECTION 5 MAINTENANCE

This section lists the maintenance procedures that need to be performed.

See the [Maintenance Log](#) located after this section for a complete list of maintenance procedures and intervals. Keep track of machine maintenance by filling in the machine hours and the date you perform each procedure.



This symbol identifies the interval (hours of operation) at which each maintenance procedure should be performed. Procedures that should be performed “as required” are indicated by “A/R”.

Be sure to refer to option and engine manuals for other maintenance procedures.

5.1 Blade Guides (Standard Block/Roller Guides)

NOTE: Block/Roller Guides are standard on the LT300.
[See Section 5.2](#) for optional Block Guide maintenance instructions.

1. Check the rollers for performance and wear every blade change. Make sure the rollers are clean and spinning freely. If not, replace them. Replace any rollers which have worn smooth or have become cone shaped.
2. Inspect the blocks at every blade change for damage or wear. If the block housing is bent or damaged, replace the block assembly. Also, replace the block assemblies before the blocks are worn to a point the blade may contact the block housing.
3. Check the guide blocks are properly spaced from the blade every 25 hours of operation. Use the provided shim or a feeler gauge to check the blocks are adjusted .008” - .010” from the blade.



As the blocks wear, the front inside corner will wear more than the body of the block. When the corner wears far enough, sawing performance will be affected even if the body of the block is adjusted properly to the blade. At this point, the block should be replaced. If you have access to the appropriate equipment, you can grind or mill the blocks to a new flat surface and reuse them. It is recommended you develop a routine schedule for replacing the blade guide blocks based on your sawing conditions and experience.

See Figure 5-1.

To adjust the top block up, loosen the clamp bolt and mounting bolt. Turn the adjustment bolt counterclockwise. Retighten the mounting bolt and clamp bolt.

To adjust the bottom block up, loosen the clamp bolt and mounting bolt. Use the provided adjustment tool to turn the adjustment screw clockwise. Retighten the mounting bolt and clamp bolt.

IMPORTANT! The blocks should be parallel to the blade. [See Section 7.2](#) for instructions about checking and adjusting the assembly level with the blade.

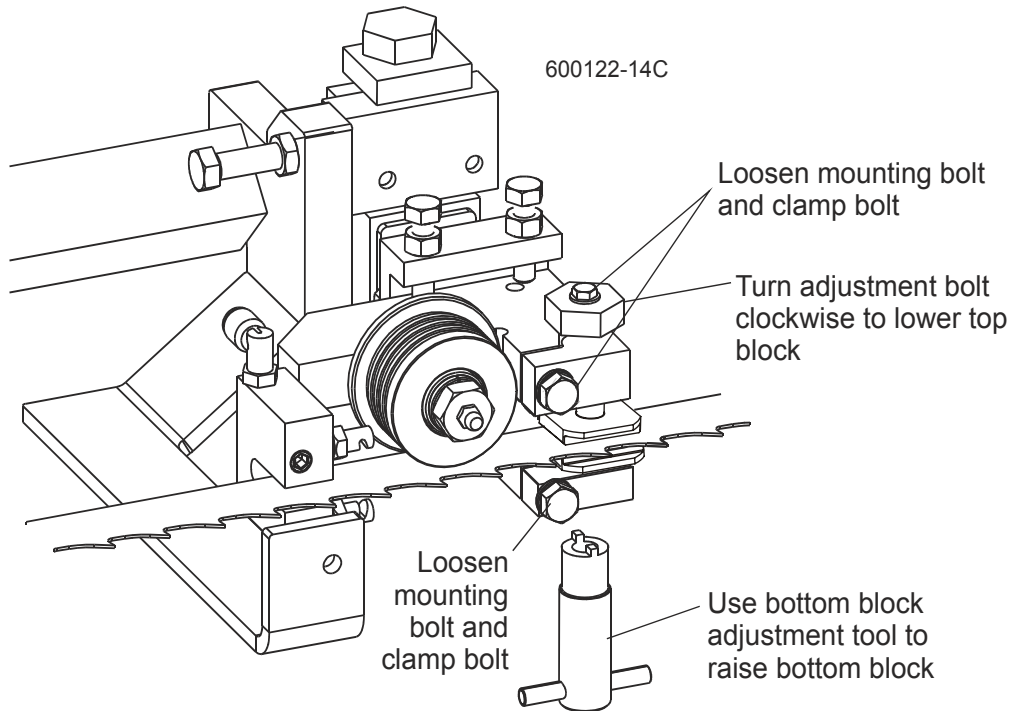

FIG. 5-1

Preventing sap buildup on the blade is critical when using the high-performance blade guide system. If the wood you are sawing leaves sap buildup using plain water in the blade lube system, use AWMV lube additive (part no. 033439).

5.2 Blade Guides (Optional Block Guides)



Inspect the blade guide assemblies for proper alignment everytime you change the blade. [See Section 7.2](#) for blade guide adjustment instructions.



WARNING! Blade guide alignment is essential for optimal cutting performance, blade life and safety. Failure to check and maintain proper blade guide alignment will result in stress cracks forming in the blade. These cracks will lead to premature blade breakage. If the blade breaks during operation and the blade has multiple stress cracks, the blade could shatter into several pieces and escape from the protective guards of the sawmill. Small blade pieces projected into the area around the sawmill creates a safety hazard for the operator and any bystanders surrounding the mill.

1. Blow sawdust from both blade guide assemblies.

See Figure 5-1.

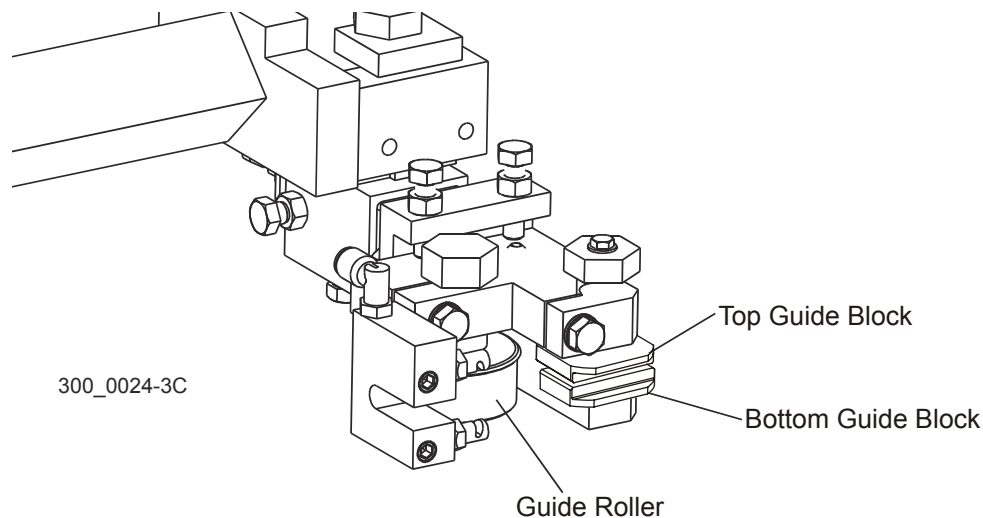

FIG. 5-1

2. Inspect the blocks at every blade change for damage or wear. If the block housing is bent or damaged, replace the block assembly. Also, replace the block assemblies before the blocks are worn to a point the blade may contact the block housing.
3. Check that the blade guide rollers spin freely. Replace any roller that does not spin freely by hand.
4. If the blade to be installed is a previously used blade, inspect it for stress cracks.



WARNING! DO NOT use blades with stress cracks. Blades with stress cracks can shatter causing bodily injury and/or machine damage.

5. Install the blade and track it on the blade wheels ([See Section 4.7](#)).
6. Make sure the top and bottom guide blocks are aligned with the back edge of the blade.
7. Check the guide blocks are properly spaced from the blade. The bottom block should touch the blade, but not deflect it upward. Use the provided shim or a feeler gauge to check the blocks are adjusted .008" - .010" from the blade. Recheck the block spacing every 25 hours of operation.

25

As the blocks wear, the front inside corner will wear more than the body of the block. When the corner wears far enough, sawing performance will be affected even if the body of the block is adjusted properly to the blade. At this point, the block should be replaced. If you have access to the appropriate equipment, you can grind or mill the blocks to a new flat surface and reuse them. It is recommended you develop a routine schedule for replacing the blade guide blocks based on your sawing conditions and experience.

8. Check that each guide roller is positioned 1/8" from the back of the blade.
9. If a groove is worn in the portion of the roller where the blade hits, adjust the roller up or down so the blade hits a new portion of the roller. Flip or replace the roller once there are no unworn locations to use.
10. Make sure the blade support channel in the center of the C-frame is 1/16" (1.5 mm) away from the blade. If not, loosen the mounting bolts and adjust the channel as necessary. Check the channel every blade change. Failing to maintain this adjustment will lead to early blade breakage.

See Figure 5-2.

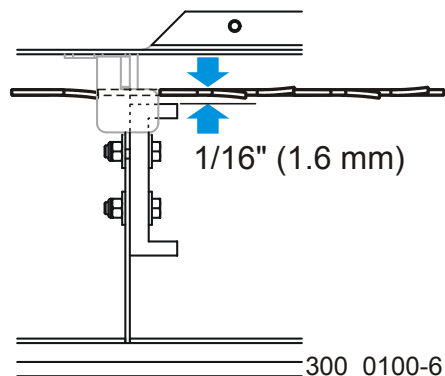

FIG. 5-2

5.3 Sawdust Removal



Remove the excess sawdust from the blade guide assemblies, blade wheel housings, throat and sawdust chute every blade change.

WARNING! Always keep clear of exiting sawdust. Keep hands, feet and any other objects away from the sawdust chute when operating sawmill. Failure to do so may result in serious injury.

WARNING! Always check to ensure the steel fingers inside the sawdust chute are in place before operating the sawmill. The steel fingers have been designed to help prevent a broken blade or some other object from becoming a projectile and exiting the sawdust chute. Failure to have these fingers in place may result in serious injury.



Remove all sawdust and debris from around the velocity fuse valves on the bottom of the log loader cylinders every 8 hours of operation.

Remove sawdust buildup from the area around the bottom up/down screw bellows. Also remove sawdust from the cable carrier tray.

5.4 Track Rails & Scrapers

Properly maintaining the sawmill carriage track is critical in preventing corrosion that can cause pitting and scaling on the rail surfaces. Pitted and scaled surfaces can, in turn, cause rough cuts or jerky power feed movement.

See Figure 5-1.

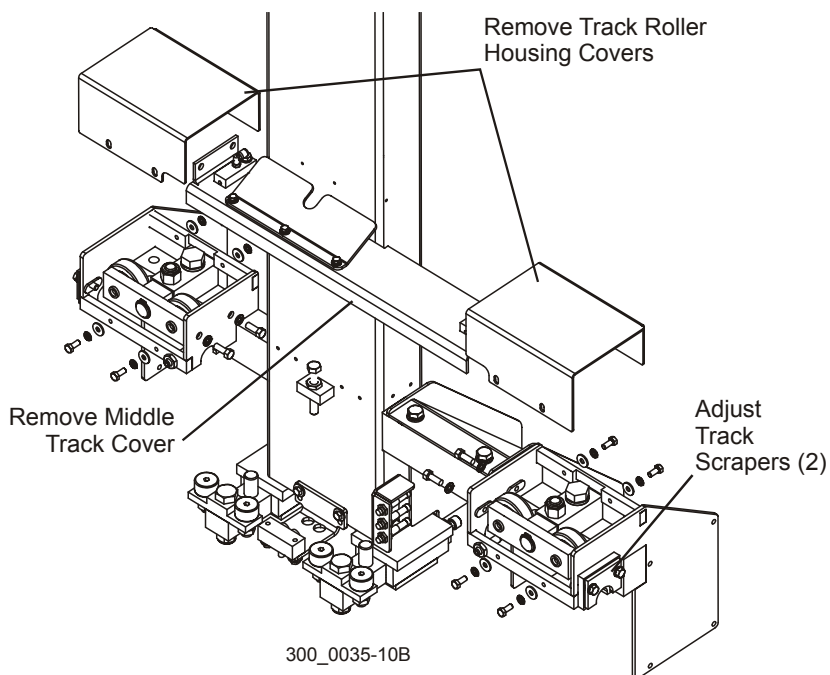

FIG. 5-1

- 1.** Clean track rails to remove any sawdust and sap buildup every fifty hours of operation.

50

Use a light-grade sandpaper or emery cloth to sand off any rust or other adhering particles from the rails.



CAUTION! Keep track rails free of rust. Formation of rust on the track rail in the areas where the cam bearings roll can cause rapid deterioration of the track rail surface.

- 8 2. Lubricate the track rails with Dexron III ATF transmission fluid. Oil lubrication will help protect the rails from corrosive elements such as acid rain and/or moisture from nearby bodies of saltwater (if applicable). This lubrication is essential to maintain the integrity of the track rails and track rollers and to achieve long service life.

Locate the three oil fittings and open the covers. Use an oil can to apply Dexron III until the oiler pads are soaked. Repeat this procedure every eight hours of operation.

See Figure 5-3.

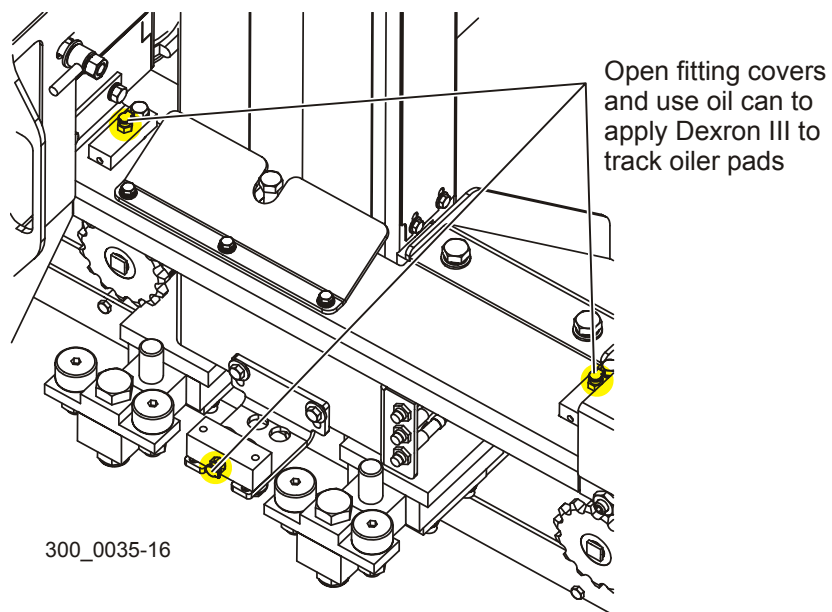

FIG. 5-3

- AR 3. Check the track scrapers as needed. Make sure the scrapers fit firmly against the rail. To adjust each scraper, loosen the two mounting bolts and push the scraper downward until it fits firmly against the rail. Retighten the mounting bolts.

5.5 Miscellaneous

1. Oil all chains with Dexron III ATF every fifty hours of operation.



CAUTION! Do not use chain lube. It causes sawdust buildup in chain links.

2. Apply a thin film of a Dexron III ATF to the blade guide arm every fifty hours of operation to help prevent it from rusting.



3. Adjust the blade guide arm drive chain as necessary to prevent the arm from slipping. To adjust the chain, loosen the blade guide arm motor mounting plate bolts and slide the motor to take slack out of the chain. To adjust the chain, loosen the blade guide arm motor mounting plate bolts and slide the motor to take slack out of the chain.



4. Grease the pivot points of the operator seat (2), log clamp (1), log loader (6), log turner (1), rear toe board (1) and side supports (6) with a NLGI No. 2 grade lithium grease every fifty hours of operation.



5. Make sure all safety warning decals are readable. Remove sawdust and dirt. Replace any damaged or unreadable decals immediately. Order decals from your Customer Service Representative.

5.6 Proximity Sensors

Proximity sensors are used in various locations to ensure proper operation of the sawmill. Check the sensors periodically or when errors in operation occur with the following systems.

5.6.2 Feed Slow-down/Stop Sensors

See Figure 5-4. Three sensors located at the bottom of the saw carriage assist in slowing or stopping the saw carriage at each end of the bed. The bottom two sensors are activated by a plate at the rear of the saw frame tube to slow then stop the saw carriage before it reaches the rear end of the track.

All three sensors are activated by a long plate at the front of the saw frame tube to slow and stop the saw carriage as it approaches the front of the track when returning to start a new cut.

Check that the areas between the sensors and the activator plates are clear of sawdust buildup or obstructions that could result in false sensor readings. Be sure each sensor is lit when positioned over the corresponding activator plate. Loosen the jam nut and adjust the sensor away from the activator plate until the sensor light goes out. Then adjust back in until the sensor light comes on plus one full turn. Tighten the jam nut.

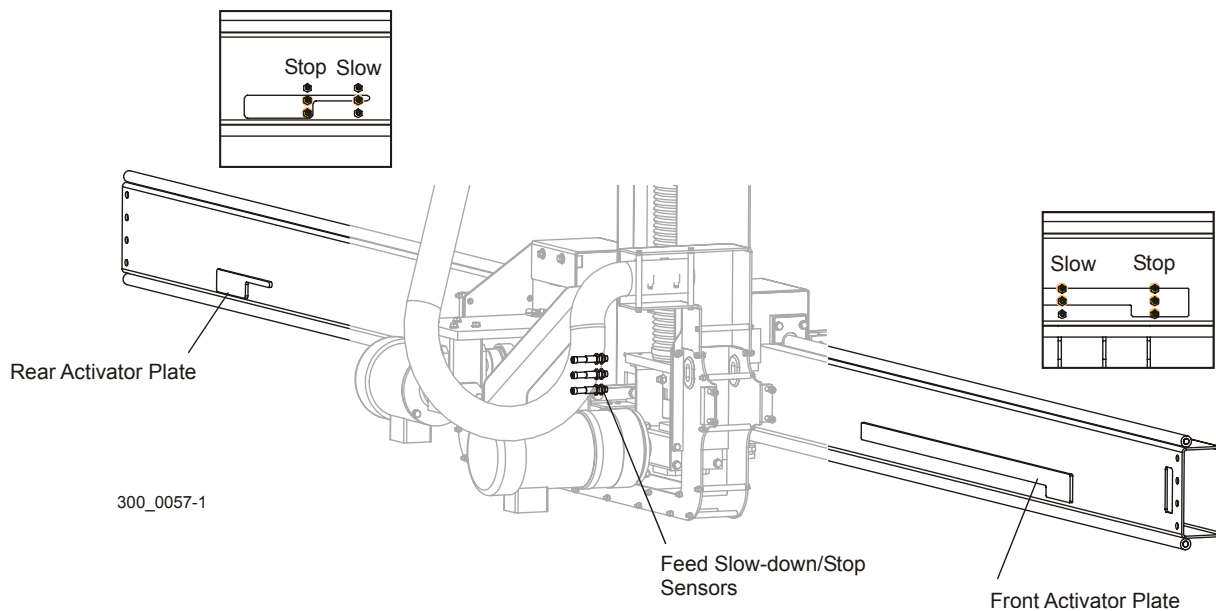

FIG. 5-4

5.6.3 Broken Blade Sensor

See Figure 5-5. A sensor located under the blade motor mounting plate detects when a blade breaks and stops the saw. When a blade breaks, the saw motor drops to its idle position, activating the sensor and alerting the operator with the Check Machine light and the message “Broken Blade Shutdwn” on the control display.

Check that the area between the sensor and the motor mount plate are clear of sawdust buildup or obstructions that could result in false sensor readings. Remove the blade if necessary and check the sensor is lit when the motor is in the idle position (resting on the stop bolt). Loosen the jam nut and adjust the sensor away from the motor mount plate until the sensor light goes out. Then adjust back in until the sensor light comes on plus one full turn. Tighten the jam nut.

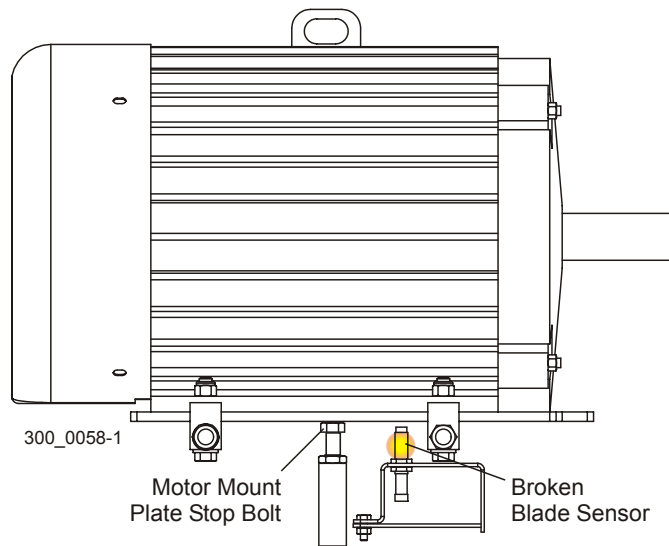

FIG. 5-5

5.6.4 Up/Down Ball Screw Sensor

See Figure 5-6. A sensor located at the middle up/down ball screw mount is activated if the saw head hits an obstruction or lower travel limit as the head is being lowered. A break-away nut separates from the mount and the sensor alerts the operator with the Check Machine light and the message “Head Down Obstructed” on the control display.

Remove the obstruction and move the saw head up to re-engage the ball screw nut. If the error occurs at the bottom of the saw head travel limit, clear sawdust or obstructions from the area around the bottom of the ball screw bellows that might cause the nut to break-away before reaching the actual lower travel limit.

Check that the areas between the sensor and the ball screw nut are clear of sawdust buildup or obstructions that could result in false sensor readings. Be sure the sensor is lit when positioned over the ball screw nut. Loosen the jam nut and adjust the sensor away from the nut until the sensor light goes out. Then adjust back in until the sensor light comes on plus one full turn. Tighten the jam nut.

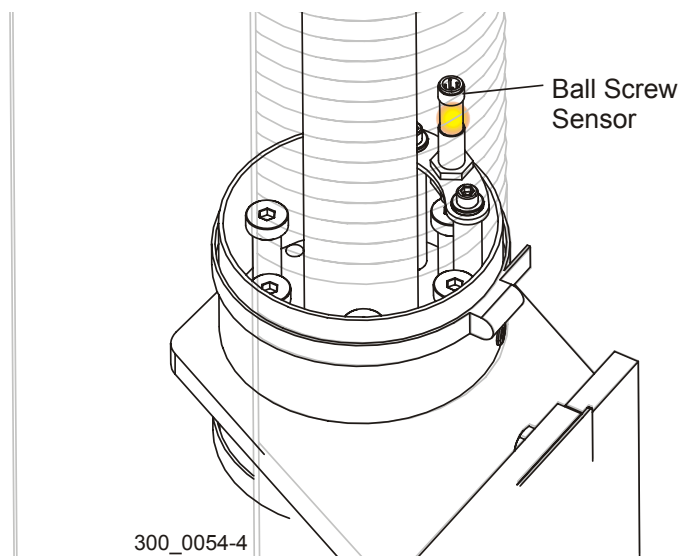

FIG. 5-6

5.7 Hydraulic System Maintenance

1. Check the hydraulic tank fluid every fifty hours of operation. The sight gauge on the tank should indicate a fluid level between LOW and HIGH. Add an all-season hydraulic fluid such as Exxon Unavis HVI 26 as needed to maintain proper fluid level.

50

If the fluid appears brown or cloudy, has an unusual 'burnt' odor, or if there is a sudden rise in oil temperature above 160°, completely drain the hydraulic tank and refill with new fluid. Also, remove and clean the suction strainer from the end of the hydraulic tank. Blow out any debris from the strainer and clean with a non-petroleum solvent before reinstalling to the tank.

2. Inspect the hydraulic lines and fittings for leaks every fifty hours of operation or as fluid appears around the machine.

50

3. Replace the S28 cartridge filter on the back of the hydraulic fluid tank every 500 hours of operation.

500

4. Completely drain the reservoir and refill with new fluid every 2000 hours of operation. Also, remove and clean the suction strainer from the end of the hydraulic tank. Blow out any debris from the strainer and clean with a non-petroleum solvent before reinstalling to the tank.

2000

5.8 Blade Wheel Bearings & Scrapers

50

Standard Belted Blade Wheels Only: Rotate the blade wheel belts and check them for wear. Rotating the belts every 50 hours will provide longer belt life. Replace belts as necessary. Use only B76 belts manufactured by Goodyear or Browning.

A/R

Optional Crowned Blade Wheels Only: Inspect the blade wheel scrapers at every blade change. The scrapers are self-adjusting and only need replaced when they no longer contact the blade wheel. When one side of the scraper is worn, remove it and flip it over to use the other side.

750

See Figure 5-5. Lubricate the blade wheel hub bearings every 750 hours of operation with a high-quality synthetic grease such as Amoco Rycon #2 or Chevron SRI #2.

1. Remove the dust cap from the hub.
2. Pump grease from a grease gun into the grease fitting until the new grease is seen exiting the hub bearings.
3. Replace the dust cap.

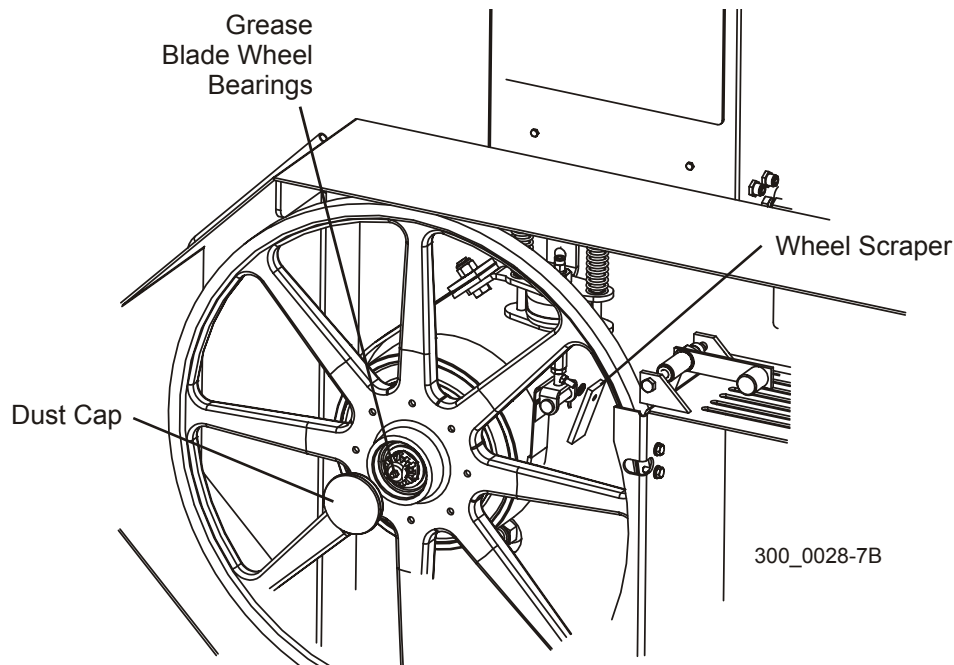

FIG. 5-5

5.9 Up/Down System

500

See Figure 5-6. Lubricate the up/down ballscrew with TriGEL-450R grease every 500 hours of operation. Wood-Mizer provides ballscrew grease in 10cc syringes for convenient application. Lubrication may be required sooner if environmental conditions require it. If the lubricant appears to have dispersed or is dry or crusted, reduce the maintenance interval.

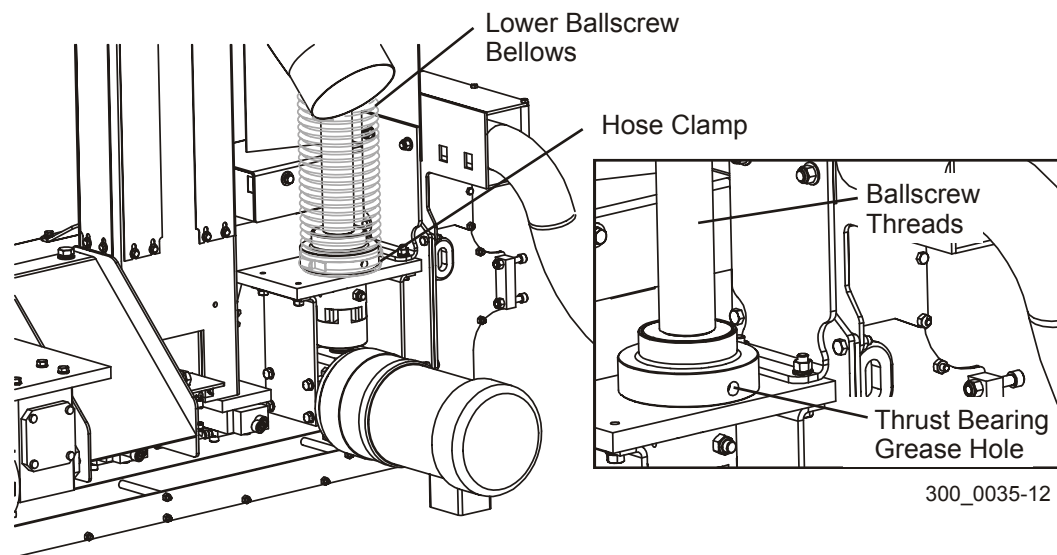



FIG. 5-6

1. Lower the saw head all the way down and blow off sawdust from around the upper ballscrew bellows.
2. Raise the saw head all the way up and blow off sawdust from around the lower ballscrew bellows. Remove the top hose clamp from the lower bellows to access the ballscrew.
3. Inspect the condition of the ballscrew lubricant. If the lubricant appears to have dispersed or is dry or crusted, reduce the maintenance interval. Remove any old grease and/or particle buildup from the screw.
4. Apply 10cc of lubricant directly to the ballscrew threads. Start just below the ballscrew nut and lubricate the threads down as far as the lower bellows will allow.
5. Remove the bottom hose clamp from the lower bellows. Lift the bellows up and continue applying lubricant to the ballscrew threads down to the thrust bearing housing.
6. Remove the screw plugging the hole in the thrust bearing mount. Apply 5cc of lubricant through the hole to lubricate the thrust bearing. Replace the plug screw.

5 Maintenance

Up/Down System

7. Reattach the lower ballscrew bellows and secure with the hose clamps. Raise and lower the saw head to work the grease along the entire length of the ballscrew.

 Check the up/down gearbox oil level. Add a synthetic gear oil such as Mobil SHC 634 as needed.

 Drain and refill the gearbox with 14 ounces of oil after the first 100 hours of sawmill operation. Repeat every 5000 hours or once a year, whichever comes first.

Wood-Mizer offers replacement gear oil in 8 ounce bottles (2 required for complete oil replacement).

 Check the up/down mast rails for excessive sawdust buildup every 50 hours of operation. Adjust the mast rail scrapers if necessary. Turn the adjustment bolts clockwise to tighten the scrapers. The scrapers should just be snug against the mast rails; do not overtighten.

See Figure 5-7.

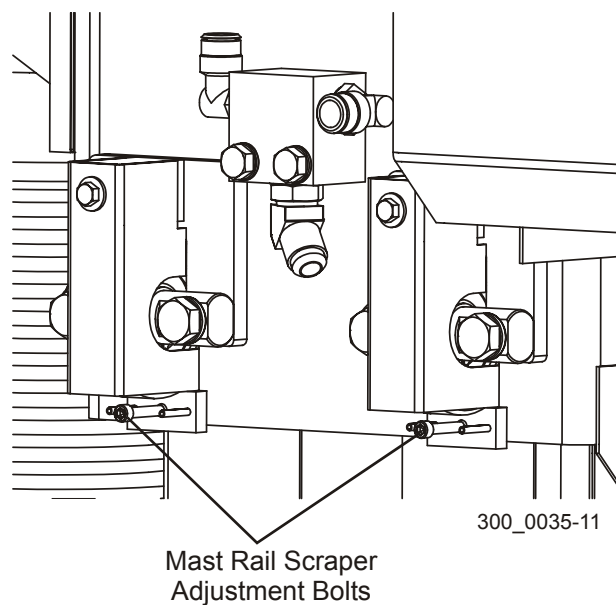

FIG. 5-6

5.10 Power Feed

- 50 1. Check the feed chain tension every 50 hours of operation and adjust as needed. Measure the power feed chain tension with the saw head all the way toward the front of the mill (furthest from control station). Use the adjustment nut on the feed tensioner at the rear of the mill to tighten or loosen the power feed chain. Adjust the chain until it measures 13 inches ($\pm 1/2$ ") from the top of the top rail at its lowest point.



CAUTION! Do not overtighten the feed chain. Damage to the power feed motor may result.

See Figure 5-7.

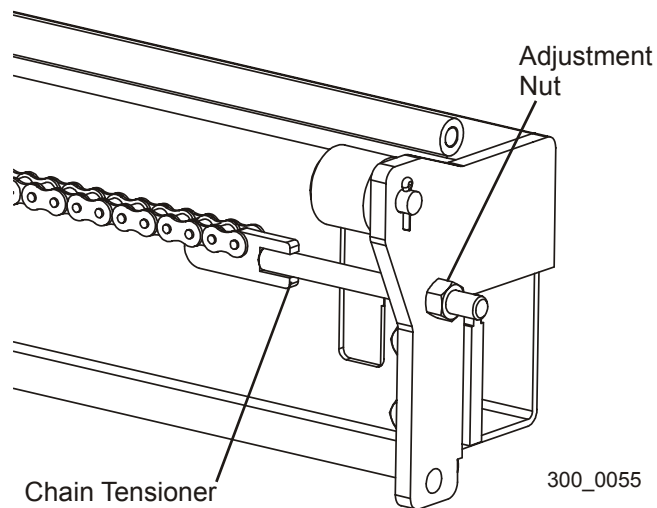

FIG. 5-7

See Figure 5-8. Refer to this figure for feed chain routing instructions.

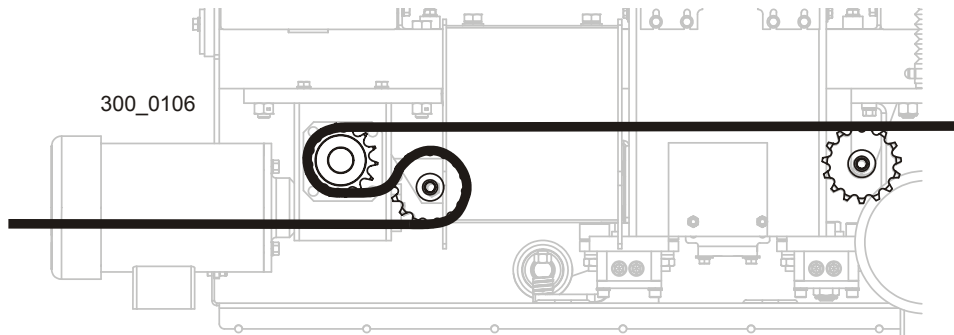

FIG. 5-7

2. Lubricate the feed chain with Dexron III ATF every fifty hours of operation.

50



CAUTION! Do not use chain lube. It causes sawdust-buildup in chain links.

A/R

Check the power feed gearbox oil level. Add a synthetic gear oil such as Mobil SHC 634 as needed.

5000

Drain and refill the gearbox with 14 ounces of oil after the first 100 hours of sawmill operation. Repeat every 5000 hours or once a year, whichever comes first.

AWMV offers replacement gear oil in 8 ounce bottles (2 required for complete oil replacement).

3. Inspect the power feed drive system for worn sprockets, chain links, etc... every 500 hours of operation. Replace or repair components as necessary.

500

See **Figure 5-8**. An access hole is provided in the bed frame tube to allow removal of the feed chain idler sprocket without disassembling the entire power feed unit. Move the saw carriage forward or backward until the sprocket bolt can be seen through the access hole.

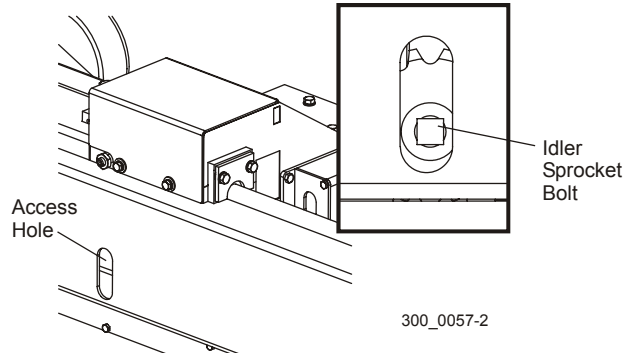

FIG. 5-8

See **Figure 5-9**. Check that the feed drive shaft coupler set screws are tight.

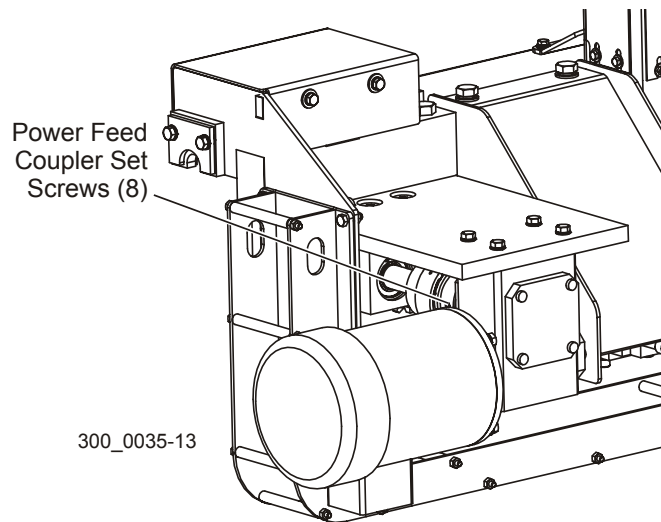

FIG. 5-8

5.11 Drive Belt Tension



Check the drive belt tension after the first 5 hours of operation, then every 50 hours thereafter.



WARNING! Do not for any reason adjust the drive belt with the motor running. Doing so may result in serious injury.



CAUTION! Always keep proper tension on the drive belt. Improper tension can ruin the belt. A loose drive belt can also cause wavy cuts, the blade to slow or stop in the cut or the cruise control to not operate properly.

See the table below for drive belt tension specifications.

| Belt Type | After First | Then Every | Belt Tension |
|-----------|-------------|------------|--|
| PD | 5 hrs | 50 hrs | 1/2" (12.5mm) deflection with 41 lbs. of deflection force ¹ |

¹ If installing a new drive belt, initially tension the belt to 57 lbs. then 41 lbs. for subsequent adjustments.

See Figure 5-10. To adjust the belt, loosen the four motor mount bolt nuts. Loosen the adjustment bolt jam nuts and turn both adjustment bolts to move the motor and tension the belt. Recheck belt tension, adjust as necessary and retighten the adjustment bolt jam nuts and motor mount bolt nuts.

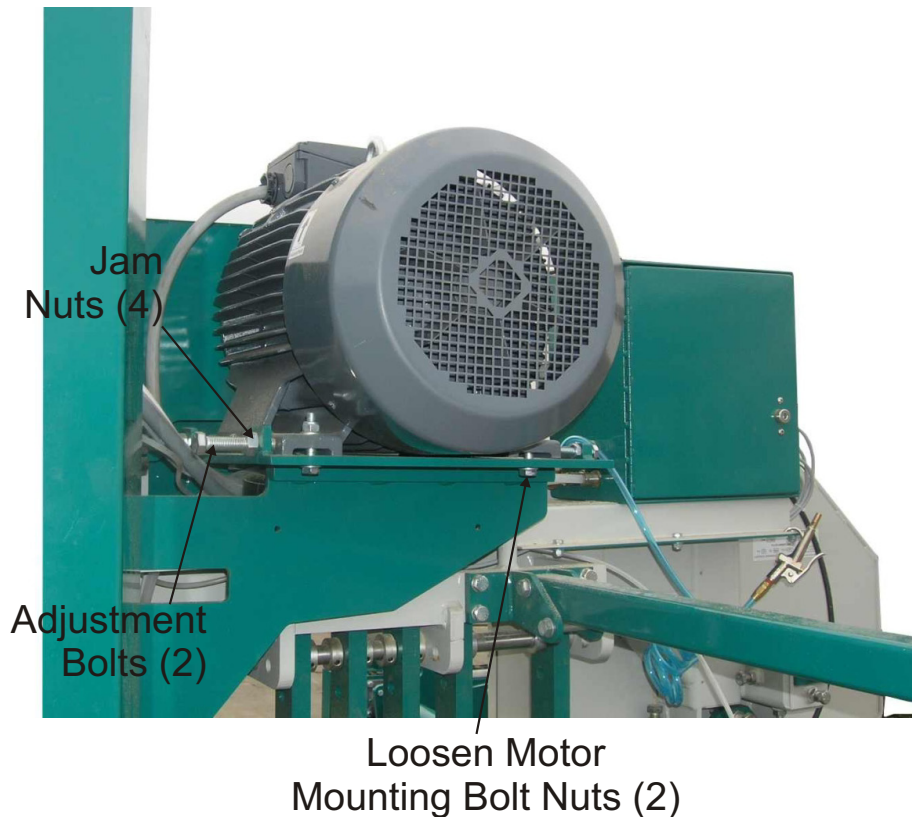

FIG. 5-10

Check alignment of the drive pulley and motor pulley after adjustment. Be sure the pulleys stay in the same plane and parallel. If necessary, loosen the motor mount bolts and use the adjustment bolts adjust the position of the motor to align the pulleys. Recheck belt tension and retighten the mounting bolts.

5.12 Turner Chain Tension



Adjust the turner chain tension as necessary to keep the turner operating properly. If the chain becomes too loose, the log will catch on the support bracket and not turn.

See Figure 5-9. To adjust the chain tension, loosen the clamping bolt nut and the jam nut on the adjustment bolt. Turn the adjustment bolt counterclockwise to tighten the chain until it is aligned with the curved portion of the support bracket. Retighten the jam nut and the clamping bolt nut.

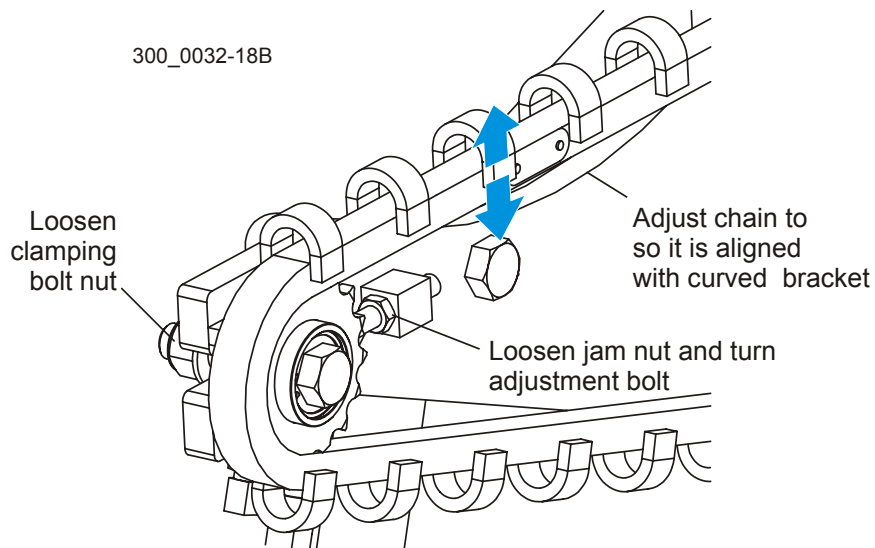

FIG. 5-10

MAINTENANCE LOG

(Check Engine And Option Manuals For Additional Maintenance Procedures)

| | | | |
|---|---------------------------------|----------------------------|------------------------------|
| Inspect blade guide block/roller wear | See Section 5.2 | Daily - Every Blade Change | DAILY MAINTENANCE PROCEDURES |
| Remove excess sawdust from blade wheel housings, sawdust chute and blade guides | See Section 5.3 | Daily - Every Blade Change | |
| Inspect fingers inside sawdust chute | See Section 5.3 | Daily - Every Blade Change | |
| Inspect blade wheel scrapers (Optional Crowned Blade Wheels Only) | See Section 5.8 | Daily - Every Blade Change | |
| Oil track rail pads | See Section 5.4 | Daily - Every 8 hours | |
| Clean sawdust from hydraulic loader fuses and bottom up/down ballscrew bellows | See Section 5.3 | Daily - Every 8 Hours | |
| Check Blade Guide Block Spacing | See Section 5.2 | Bi-Weekly - Every 25 Hours | |

| PROCEDURE | REFERENCE | TOTAL HOURS OF OPERATION FILL IN THE DATE AND THE MACHINE HOURS AS YOU PERFORM EACH PROCEDURE. A SHADED BOX INDICATES MAINTENANCE IS NOT NEEDED AT THIS TIME. | | | | | | | | | |
|--|---|---|---------|---------|---------|---------|---------|---------|---------|---------|---------|
| | | 50 HRS | 100 HRS | 150 HRS | 200 HRS | 250 HRS | 300 HRS | 350 HRS | 400 HRS | 450 HRS | 500 HRS |
| Clean and lubricate track, check track scrapers | See Section 5.4 | | | | | | | | | | |
| Check mast rails and adjust scrapers | See Section 5.9 | | | | | | | | | | |
| Grease pivot points and bearings/Oil chains | See Section 5.5 | | | | | | | | | | |
| Check drive belt tension | See Section 5.11 | | | | | | | | | | |
| Rotate drive/idle blade wheel belts/Check for wear (Standard Belted Blade Wheels Only) | See Section 5.8 | | | | | | | | | | |
| Lubricate blade wheel bearings | See Section 5.8 | | | | | | | | | | |
| Lubricate feed chain and check chain tension | See Section 5.10 | | | | | | | | | | |
| Lubricate up/down ballscrew & thrust bearing | See Section 5.9 | | | | | | | | | | |
| Replace up/down and power feed gearbox oil ^a | See Section 5.9 See Section 5.10 | | | | | | | | | | |
| Inspect feed chain, sprockets and coupler | See Section 5.10 | | | | | | | | | | |
| Inspect hydraulic lines & fittings | See Section 5.7 | | | | | | | | | | |
| Check hydraulic fluid level | See Section 5.7 | | | | | | | | | | |
| Replace hydraulic system filter | See Section 5.7 | | | | | | | | | | |
| Inspect hydraulic pump motor brushes | See Section 5.7 | | | | | | | | | | |

^a Replace fluid after first 100 hours, then every year or 5000 hours thereafter.

MAINTENANCE LOG

| PROCEDURE | REFERENCE | TOTAL HOURS OF OPERATION | | | | | | | | | |
|---|---|---|---------|---------|---------|---------|---------|---------|---------|---------|----------|
| | | FILL IN THE DATE AND THE MACHINE HOURS AS YOU PERFORM EACH PROCEDURE. A SHADED BOX INDICATES MAINTENANCE IS NOT NEEDED AT THIS TIME. | | | | | | | | | |
| | | 550 HRS | 600 HRS | 650 HRS | 700 HRS | 750 HRS | 800 HRS | 850 HRS | 900 HRS | 950 HRS | 1000 HRS |
| Clean and lubricate track, check track scrapers | See Section 5.4 | | | | | | | | | | |
| Check mast rails and adjust scrapers | See Section 5.9 | | | | | | | | | | |
| Grease pivot points and bearings/Oil chains | See Section 5.5 | | | | | | | | | | |
| Check drive belt tension | See Section 5.11 | | | | | | | | | | |
| Rotate drive/idle blade wheel belts/Check for wear (Standard Belted Blade Wheels Only) | See Section 5.8 | | | | | | | | | | |
| Lubricate blade wheel bearings | See Section 5.8 | | | | | | | | | | |
| Lubricate feed chain and check chain tension | See Section 5.10 | | | | | | | | | | |
| Lubricate up/down ballscrew & thrust bearing | See Section 5.9 | | | | | | | | | | |
| Replace up/down and power feed gearbox oil | See Section 5.9 See Section 5.10 | | | | | | | | | | |
| Inspect feed chain, sprockets and coupler | See Section 5.10 | | | | | | | | | | |
| Inspect hydraulic lines & fittings | See Section 5.7 | | | | | | | | | | |
| Check hydraulic fluid level | See Section 5.7 | | | | | | | | | | |
| Replace hydraulic system filter | See Section 5.7 | | | | | | | | | | |
| Inspect hydraulic pump motor brushes | See Section 5.7 | | | | | | | | | | |

MAINTENANCE LOG

| PROCEDURE | REFERENCE | TOTAL HOURS OF OPERATION | | | | | | | | | |
|---|---|---|----------|----------|----------|----------|----------|----------|----------|----------|----------|
| | | FILL IN THE DATE AND THE MACHINE HOURS AS YOU PERFORM EACH PROCEDURE. A SHADED BOX INDICATES MAINTENANCE IS NOT NEEDED AT THIS TIME. | | | | | | | | | |
| | | 1050 HRS | 1100 HRS | 1150 HRS | 1200 HRS | 1250 HRS | 1300 HRS | 1350 HRS | 1400 HRS | 1450 HRS | 1500 HRS |
| Clean and lubricate track, check track scrapers | See Section 5.4 | | | | | | | | | | |
| Check mast rails and adjust scrapers | See Section 5.9 | | | | | | | | | | |
| Grease pivot points and bearings/Oil chains | See Section 5.5 | | | | | | | | | | |
| Check drive belt tension | See Section 5.11 | | | | | | | | | | |
| Rotate drive/idle blade wheel belts/Check for wear (Standard Belted Blade Wheels Only) | See Section 5.8 | | | | | | | | | | |
| Lubricate blade wheel bearings | See Section 5.8 | | | | | | | | | | |
| Lubricate feed chain and check chain tension | See Section 5.10 | | | | | | | | | | |
| Lubricate up/down ballscrew & thrust bearing | See Section 5.9 | | | | | | | | | | |
| Replace up/down and power feed gearbox oil | See Section 5.9 See Section 5.10 | | | | | | | | | | |
| Inspect feed chain, sprockets and coupler | See Section 5.10 | | | | | | | | | | |
| Inspect hydraulic lines & fittings | See Section 5.7 | | | | | | | | | | |
| Check hydraulic fluid level | See Section 5.7 | | | | | | | | | | |
| Replace hydraulic system filter | See Section 5.7 | | | | | | | | | | |
| Inspect hydraulic pump motor brushes | See Section 5.7 | | | | | | | | | | |

MAINTENANCE LOG

| PROCEDURE | REFERENCE | TOTAL HOURS OF OPERATION | | | | | | | | | |
|---|---|---|----------|----------|----------|----------|----------|----------|----------|----------|----------|
| | | FILL IN THE DATE AND THE MACHINE HOURS AS YOU PERFORM EACH PROCEDURE. A SHADED BOX INDICATES MAINTENANCE IS NOT NEEDED AT THIS TIME. | | | | | | | | | |
| | | 1550 HRS | 1600 HRS | 1650 HRS | 1700 HRS | 1750 HRS | 1800 HRS | 1850 HRS | 1900 HRS | 1950 HRS | 2000 HRS |
| Clean and lubricate track, check track scrapers | See Section 5.4 | | | | | | | | | | |
| Check mast rails and adjust scrapers | See Section 5.9 | | | | | | | | | | |
| Grease pivot points and bearings/Oil chains | See Section 5.5 | | | | | | | | | | |
| Check drive belt tension | See Section 5.11 | | | | | | | | | | |
| Rotate drive/idle blade wheel belts/Check for wear (Standard Belted Blade Wheels Only) | See Section 5.8 | | | | | | | | | | |
| Lubricate blade wheel bearings | See Section 5.8 | | | | | | | | | | |
| Lubricate feed chain and check chain tension | See Section 5.10 | | | | | | | | | | |
| Lubricate up/down ballscrew & thrust bearing | See Section 5.9 | | | | | | | | | | |
| Replace up/down and power feed gearbox oil | See Section 5.9 See Section 5.10 | | | | | | | | | | |
| Inspect feed chain, sprockets and coupler | See Section 5.10 | | | | | | | | | | |
| Inspect hydraulic lines & fittings | See Section 5.7 | | | | | | | | | | |
| Check hydraulic fluid level | See Section 5.7 | | | | | | | | | | |
| Replace hydraulic system filter | See Section 5.7 | | | | | | | | | | |
| Inspect hydraulic pump motor brushes | See Section 5.7 | | | | | | | | | | |

MAINTENANCE LOG

| PROCEDURE | REFERENCE | TOTAL HOURS OF OPERATION | | | | | | | | | |
|---|---|---|----------|----------|----------|----------|----------|----------|----------|----------|----------|
| | | FILL IN THE DATE AND THE MACHINE HOURS AS YOU PERFORM EACH PROCEDURE. A SHADED BOX INDICATES MAINTENANCE IS NOT NEEDED AT THIS TIME. | | | | | | | | | |
| | | 2050 HRS | 2100 HRS | 2150 HRS | 2200 HRS | 2250 HRS | 2300 HRS | 2350 HRS | 2400 HRS | 2450 HRS | 2500 HRS |
| Clean and lubricate track, check track scrapers | See Section 5.4 | | | | | | | | | | |
| Check mast rails and adjust scrapers | See Section 5.9 | | | | | | | | | | |
| Grease pivot points and bearings/Oil chains | See Section 5.5 | | | | | | | | | | |
| Check drive belt tension | See Section 5.11 | | | | | | | | | | |
| Rotate drive/idle blade wheel belts/Check for wear (Standard Belted Blade Wheels Only) | See Section 5.8 | | | | | | | | | | |
| Lubricate blade wheel bearings | See Section 5.8 | | | | | | | | | | |
| Lubricate feed chain and check chain tension | See Section 5.10 | | | | | | | | | | |
| Lubricate up/down ballscrew & thrust bearing | See Section 5.9 | | | | | | | | | | |
| Replace up/down and power feed gearbox oil | See Section 5.9 See Section 5.10 | | | | | | | | | | |
| Inspect feed chain, sprockets and coupler | See Section 5.10 | | | | | | | | | | |
| Inspect hydraulic lines & fittings | See Section 5.7 | | | | | | | | | | |
| Check hydraulic fluid level | See Section 5.7 | | | | | | | | | | |
| Replace hydraulic system filter | See Section 5.7 | | | | | | | | | | |
| Inspect hydraulic pump motor brushes | See Section 5.7 | | | | | | | | | | |

MAINTENANCE LOG

| PROCEDURE | REFERENCE | TOTAL HOURS OF OPERATION | | | | | | | | | |
|---|---|---|----------|----------|----------|----------|----------|----------|----------|----------|----------|
| | | FILL IN THE DATE AND THE MACHINE HOURS AS YOU PERFORM EACH PROCEDURE. A SHADED BOX INDICATES MAINTENANCE IS NOT NEEDED AT THIS TIME. | | | | | | | | | |
| | | 2550 HRS | 2600 HRS | 2650 HRS | 2700 HRS | 2750 HRS | 2800 HRS | 2850 HRS | 2900 HRS | 2950 HRS | 3000 HRS |
| Clean and lubricate track, check track scrapers | See Section 5.4 | | | | | | | | | | |
| Check mast rails and adjust scrapers | See Section 5.9 | | | | | | | | | | |
| Grease pivot points and bearings/Oil chains | See Section 5.5 | | | | | | | | | | |
| Check drive belt tension | See Section 5.11 | | | | | | | | | | |
| Rotate drive/idle blade wheel belts/Check for wear (Standard Belted Blade Wheels Only) | See Section 5.8 | | | | | | | | | | |
| Lubricate blade wheel bearings | See Section 5.8 | | | | | | | | | | |
| Lubricate feed chain and check chain tension | See Section 5.10 | | | | | | | | | | |
| Lubricate up/down ballscrew & thrust bearing | See Section 5.9 | | | | | | | | | | |
| Replace up/down and power feed gearbox oil | See Section 5.9 See Section 5.10 | | | | | | | | | | |
| Inspect feed chain, sprockets and coupler | See Section 5.10 | | | | | | | | | | |
| Inspect hydraulic lines & fittings | See Section 5.7 | | | | | | | | | | |
| Check hydraulic fluid level | See Section 5.7 | | | | | | | | | | |
| Replace hydraulic system filter | See Section 5.7 | | | | | | | | | | |
| Inspect hydraulic pump motor brushes | See Section 5.7 | | | | | | | | | | |

SECTION 6 TROUBLESHOOTING

6.1 Error Codes

| Err. # | Msg on Display | Err | Wrn | 3 Sec | Cause | Cleared by | Msg # |
|--------|----------------------|-----|-----|-------|--|--|-------|
| 2 | Blade not tensioned | x | | | 1) Mtr key to start and blade not tensioned 2) Loss of air pressure when mtr is running. | Key Swt to OFF, tension blade, air pressure restored | 102 |
| 3 | Broken Blade Shutdwn | x | | | 1) Blade breaks 2) No blade on mill and Key Swt to Start | Key Swt to OFF | 103 |
| 4 | Hyd Pump Overload | x | | | Hyd. Motor bad, shorted etc. that trips overload and the hyd. Pump is requested | Reset overload, Hyd pump turns off | 104 |
| 5 | U/D Invertor Drive | x | | | Various errors, see invertor drive manual | Press E-Stop and wait for the display to no longer show the error message. Reset drive by pressing the rst button (not recommend for normal operation) | 105 |
| 6 | PF Invertor Drive | x | | | Various errors, see invertor drive manual | Press E-Stop and wait for the display to no longer show the error message. Reset drive by pressing the rst button (not recommend for normal operation) | 106 |

6

Troubleshooting

Error Codes

| Err. # | Msg on Display | Err | Wrn | 3 Sec | Cause | Cleared by | Msg # |
|--------|----------------------|-----|-----|-------|--|---|-------|
| 7 | Blade Mtr Over-temp | x | | | Heavy use of motor | Let motor rest until internal thermostats close. Turning OFF the key switch will clear the error even if the thermostats are still open. Turning the key to ON will show the error is the thermostats are open. | 107 |
| 8 | Target Not Reached | | x | x | An automatic drop was initiated but the head failed to reach the target in 5 seconds | 3 Sec Timer | 108 |
| 9 | Blade Brake Engaged | x | | | Malfunction of brake air solenoid. | Key OFF, correct problem. This error will not occur until the motor contactors switch from start to run so the operator will see the motor run for 4 seconds then turn off. | 109 |
| 10 | Head at Lower Limit | | x | x | Head within 1" of bed | 3 Sec Timer | 110 |
| 11 | Head at Upper Limit | | x | x | Head within 1" of top of mast | 3 Sec Timer | 111 |
| 12 | Invalid PF Cal Value | | x | x | Head PF not calibrated | 3 Sec Timer | 112 |
| 13 | PF Range Error | | x | x | Failed to move speed control when instructed during calibration or error in feed control | 3 Sec Timer | 113 |

| Err. # | Msg on Display | Err | Wrn | 3 Sec | Cause | Cleared by | Msg # |
|--------|------------------------|-----|-----|-------|---|--|-------|
| 14 | !!! A/D Failure !!! | x | | | System failure | Correction of A/D | 124 |
| 15 | Head Down Obstructed | x | | | Obstruction with saw head during downward travel. | Remove obstruction and raise saw head to re-engage ballscrew nut. | 119 |
| 16 | Not Used | | | | | | 125 |
| 17 | Head Travel Sensor Err | x | | x | Stop prox was detected but not the slow down prox. (invalid condition). | 3 sec timer. Readjust the head travel prox.'s, move the head off sensing strips | 126 |
| 18 | Exceeded HP limit | x | | x | HP exceeded 75HP for 150ms | 3 sec timer. Note: the PF will stop and the will not work until the operator release the right joystick. | 150 |

6.2 Blade Guides

See Table 6-1.

| PROBLEM | CAUSE | SOLUTION |
|--|--|--|
| Heat In Blade | Blade guide blocks not properly aligned. | Align blade guides (See Section 7.2). |
| | Groove in blade guide roller not aligned with with gap between blade guide blocks. | Adjust roller to start a new groove (See Section 7.2.5). |
| Slow Or Wavy Sawing | Blade guides not properly aligned. | Align blade guides (See Section 7.2). |
| | Buildup on blade. | Use or increase blade lube. |
| Sparks From Blade Guide Inserts | Weld in a new blade contacting guide blocks. | Continue using blade until weld eventually wears. |
| | Chipped blade guide block. | Replace. |

SECTION 7 ALIGNMENT

7.1 Bed Frame

7.1.1 Level Bed Frame In Length Direction

NOTE: If the floor is extremely unlevel, the sawmill legs may not provide enough adjustment to level the bed frame in the length direction. This is not critical to maintain sawing accuracy. Level the sawmill in the length direction as closely as possible.

Move the saw head so it is positioned over the log clamp tube at the middle of the bed frame. Place a level on the main frame tube, near the front end of the sawmill. Adjust the front leg if necessary until the tube is level at that location.

See Figure 7-1. Loosen the horizontal locking bolt before adjusting the leg. Use the bottom and top adjusting nuts to raise or lower the frame tube until it is level. Tighten the adjustment nuts and the horizontal locking bolt to secure the leg in position.

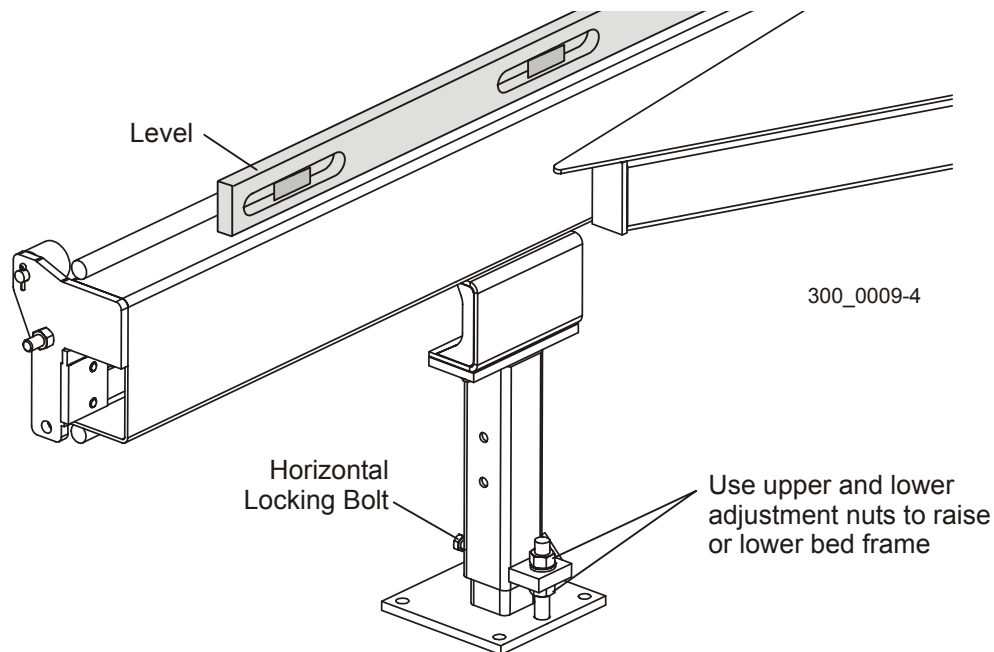

FIG. 7-1

Move the level to the center of the tube and adjust the middle legs if necessary. Move the level to the rear of the tube and adjust the rear leg if necessary.

7 Alignment

Level Bed Frame In Width Direction

7.1.2 Level Bed Frame In Width Direction

See **Figure 7-2**. To level the bed in the width direction, place two pieces of straight tubing between the front two bed rail supports. Place a level across both tubes, near the front bed rail ('A'). Adjust the outer front leg to level the bed. Move the level to the other end of the tubes ('B') and use the second outer leg to adjust level. Move the straight tubes to the rear two bed rail supports and adjust the two outer rear legs until the bed is level.

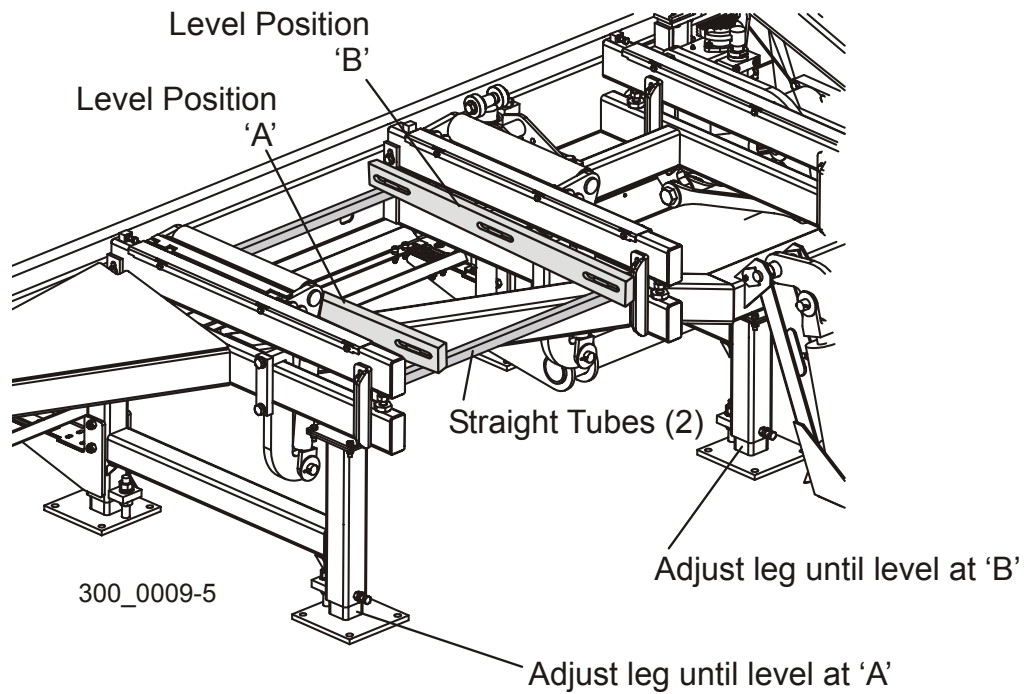

FIG. 7-2

7.1.3 Level Saw Head

Install a blade around the blade wheels. Tension and track the blade. Move the saw carriage so the blade is positioned over the log clamp tube. Adjust the blade guide arm all the way out.

See Figure 7-3. Adjust the blade guides so they do not touch the blade in any way. Loosen clamp bolt (H) and turn the top guide block bolt (F) counterclockwise to raise the top guide block off the blade. Turn blade guide assembly bolt (A) counterclockwise to move the bottom guide block down off the blade. Check that the blade guide roller does not touch the blade. Loosen clamp bolt (G) and turn roller bolt (C) if necessary to move roller away from blade.

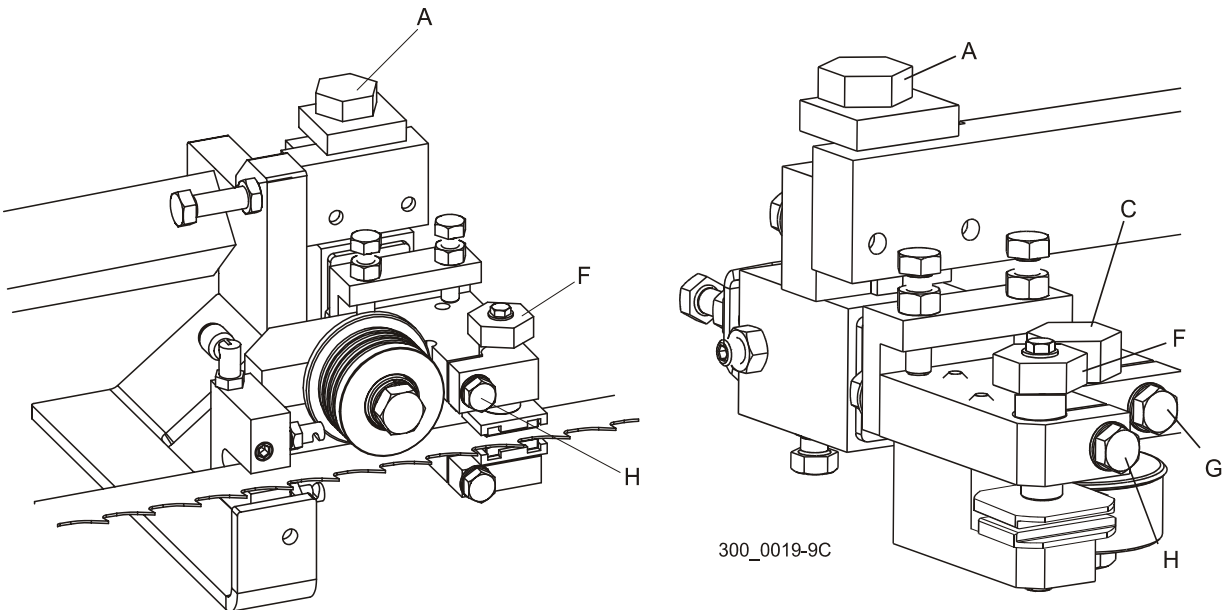

FIG. 7-3

7 Alignment

Level Saw Head

See Figure 7-4. Raise the saw head until the blade measures 15" above the clamp tube by actual measurement with a tape or rule from the bottom of the blade to the clamp tube near the inner blade guide. Measure the distance to the blade at the outer end of the clamp tube. The two measurements should be equal. If necessary, adjust the lower track rollers to tilt the saw head so the blade is parallel to the clamp tube.

To tilt the outer side of the saw head down toward the bed, loosen the adjustment bolts. Turn each adjustment bolt equally, one revolution at a time and remeasure the distance from the blade to the clamp tube. Once the blade is parallel to the clamp tube, tighten the stop bolts until they stop against the roller mount block.

To tilt the outer side of the saw head up, loosen the stop bolts and tighten the adjustment bolts. Turn each adjustment bolt equally, one revolution at a time and remeasure the distance from the blade to the clamp tube. Once the blade is parallel to the clamp tube, tighten the stop bolts until they stop against the roller mount block.

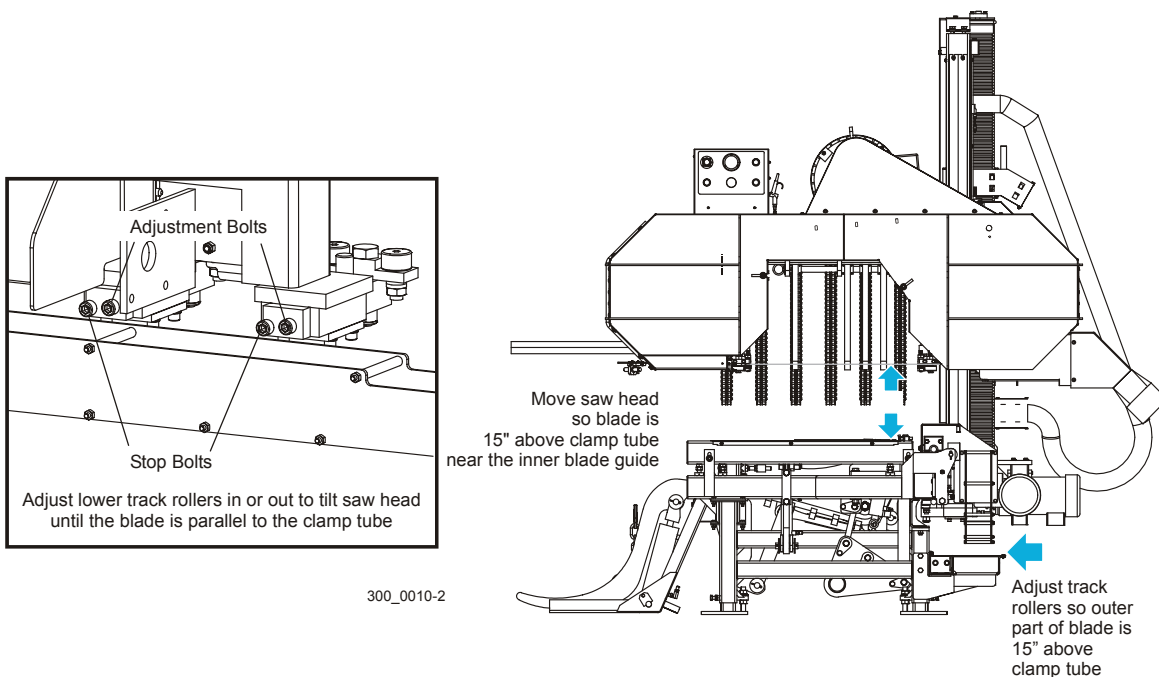

FIG. 7-4

7.1.4 Level Bed Rails

See Figure 7-5. Move the log clamp in until it is 10" from the clamp stop. Adjust the clamp down to its lowest position. Raise the saw head until the blade measures 15 5/16" above the top of the clamp. Move the saw carriage so the blade is positioned over the front bed rail. Measure the distance from the bottom of the blade to the bed rail cover at each end of the bed rail. Both measurements should be 15" (5/16" above the clamp [$\pm 1/16"$]). Loosen the bed rail clamp bolts and turn the bed rail adjustment bolts to raise or lower the bed rail, if necessary. Retighten the clamp bolts and repeat for the remaining bed rails.

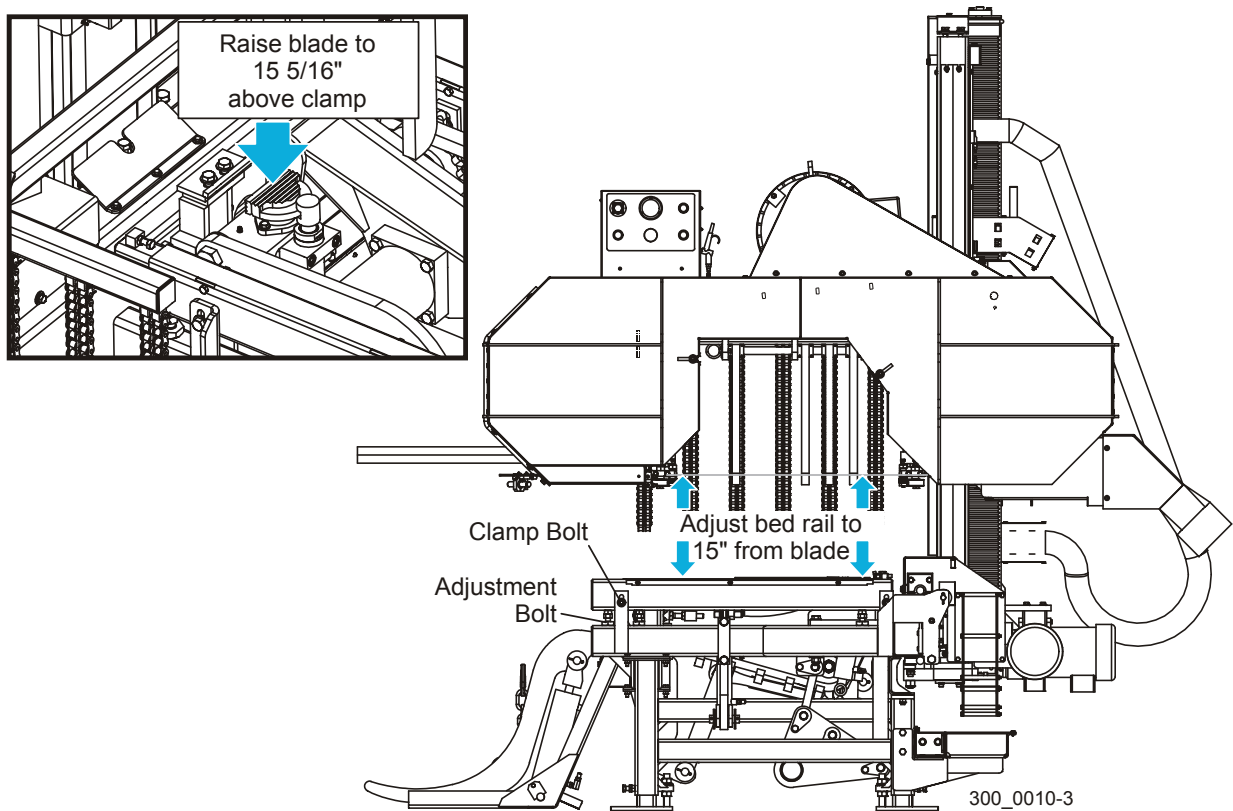

FIG. 7-5

7 Alignment

Align Side Supports

7.1.5 Align Side Supports

See Figure 7-6. Place square alignment tubes (Part No. S12831 - 2 required) across the bed rails in front of one of the side supports. Use the controls to raise the side supports all the way up. Set a square on the tubes and place against the side support. The side support should be square to the bed or tilted slightly forward $1/32''$ (0.8 mm). Adjust the tilt of the side support if necessary.

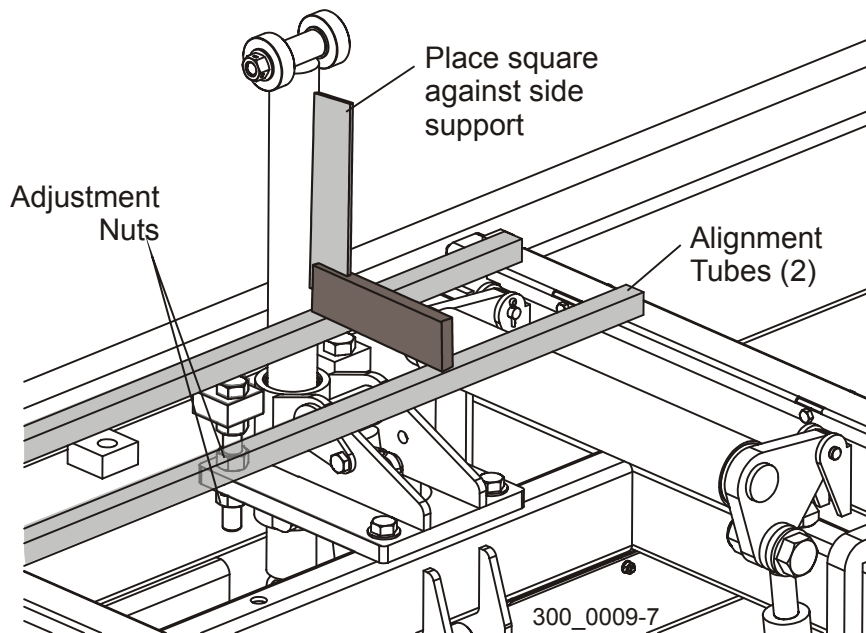

FIG. 7-6

To tilt the side support forward, loosen the top adjustment nuts and tighten the lower adjustment nuts. Adjust both sets of adjustment nuts on each side of the side support evenly. To tilt the side support back, loosen the bottom adjustment nuts and tighten the top adjustment nuts.

7.2 Blade Guides (Standard Block/Roller Guides)

NOTE: Block/Roller Guides are standard on the LT300.
[See Section 7.3](#) for optional Block Guide alignment.



WARNING! Blade guide alignment is essential for optimal cutting performance, blade life and safety. Failure to check and maintain proper blade guide alignment will result in stress cracks forming in the blade. These cracks will lead to premature blade breakage. If the blade breaks during operation and the blade has multiple stress cracks, the blade could shatter into several pieces and escape from the protective guards of the sawmill. Small blade pieces projected into the area around the sawmill creates a safety hazard for the operator and any bystanders surrounding the mill.

WARNING! DO NOT use blades with stress cracks. Blades with stress cracks can shatter causing bodily injury and/or machine damage.

7.2.1 Blade Guide Adjustment Overview

Proper blade guide alignment is critical to optimum machine performance. It is important to understand and follow the procedures in this section to properly align the blade guides.

See Figure 7-7. The major components of the blade guide assemblies are the top and bottom guide blocks and guide roller.

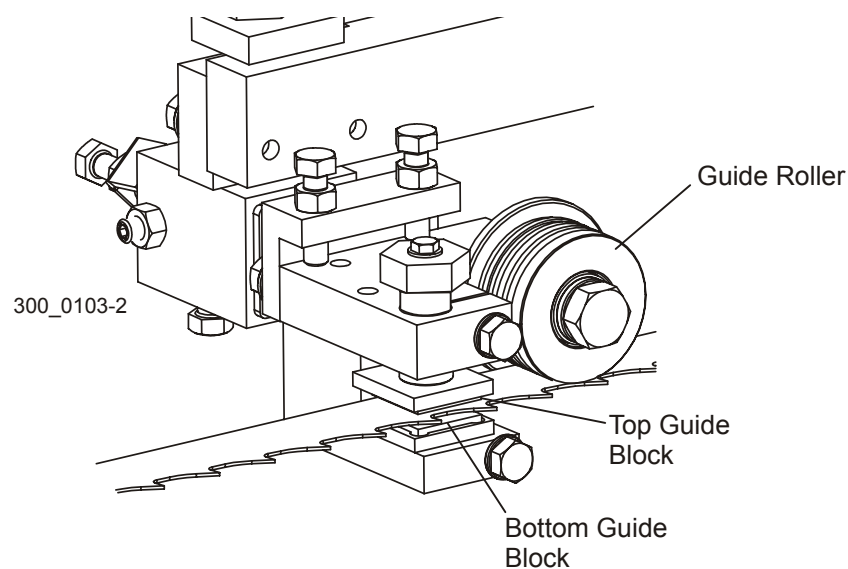

FIG. 7-7

7 Alignment

Blade Guide Adjustment Overview

See **Figure 7-8**. The objective to aligning the blades guides is to properly position the guide blocks and guide roller in relation to the blade. The roller should deflect the blade down 1/4"(6mm). The flange of the roller should be positioned 1/6"(4mm) from the back edge of the blade at the inner guide assembly and 1/5"(5mm) from the blade at the outer guide assembly. The blocks should be adjusted to .02"(0,5mm) from the blade.

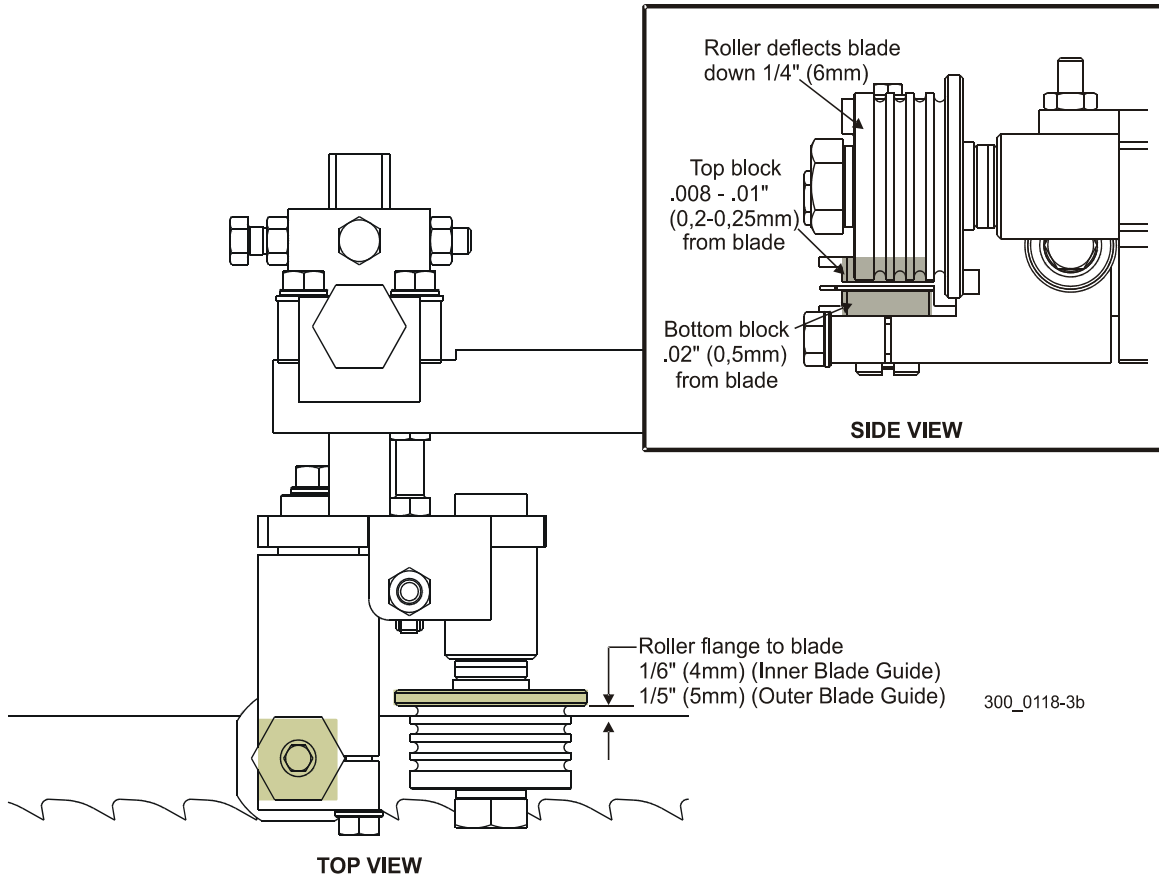

FIG. 7-8

See Figure 7-9. Adjustment bolts are provided to obtain the proper blade guide alignment. The various blade guide adjustments are described below.

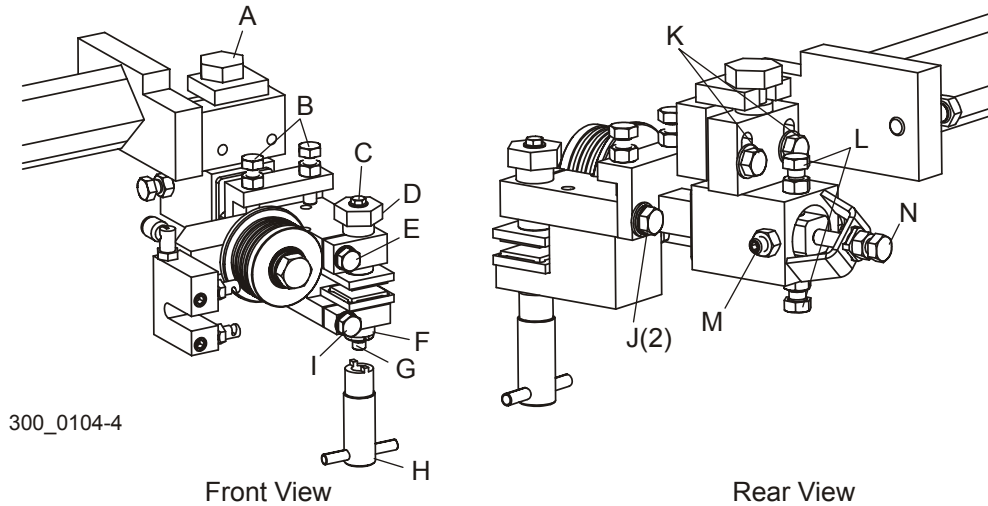

FIG. 7-9

| | |
|----------|--|
| A | Vertical Adjustment Bolt - Use to adjust entire blade guide assembly up or down. Use a 1" wrench to turn the bolt. Turning clockwise will raise assembly; counterclockwise will lower assembly. This adjustment may be made without loosening clamp bolts (K) if assembly is properly lubricated. |
| B | Guide Tilt Bolts - Use to adjust the bolts to tilt the blade guides so the guide blocks are parallel to the blade. Loosen clamp bolts (J), but leave them snug. To adjust each bolt, use a 1/2" wrench to loosen the jam nut, adjust the bolt and retighten the jam nut. Retighten clamp bolts (J). |
| C | Top Guide Block Bolt - Use to disassemble top guide block. Use 5/16" nut driver to remove bolt. |
| D | Top Guide Block Adjustment Bolt - Use to raise or lower top guide block. Use a 1/2" wrench to loosen clamp bolt (E) and turn by hand. Turn adjustment bolt by hand counterclockwise to raise top guide block; clockwise to lower top guide block. |
| E | Top Guide Block Clamp Bolt - Loosen with 1/2" wrench to allow adjustment of top guide block adjustment bolt (D). |
| F | Bottom Block Adjustment Bolt - Use to adjust bottom guide block. Loosen clamp bolt (I) and use supplied tool (H) to turn bolt. |
| G | Bottom Guide Block Bolt - Use to disassemble bottom guide block. Use 5/32" hex wrench to remove bolt. |
| H | Bottom Block Adjustment Tool - Use to adjust bottom guide block bolt (F). |
| I | Bottom Guide Block Clamp Bolt - Loosen with 1/2" wrench to allow adjustment of bottom guide block adjustment bolt (F). |
| J | Guide Block Clamp Bolts - Loosen both bolts but leave snug with 1/2" wrench to allow adjustment of guide tilt bolts (B). |

7**Alignment***Blade Guide Adjustment Overview*

| | |
|----------|---|
| K | Blade Guide Assembly Clamp Bolts - Used to secure vertical adjustment of entire blade guide assembly. Loosening these bolts is not normally required when adjusting the vertical adjustment bolt (A). Make sure these bolts are tight after making vertical adjustment. |
| L | Vertical Tilt Adjustment Bolts - Use the bolts to tilt the entire blade so it is parallel to the bed rails. Use a 1/2" wrench to loosen the jam nuts. Adjust the bolts up to tilt the blade down; adjust bolts down to tilt blade up. Retighten the jam nuts. |
| M | Blade Guide Clamp Bolt - Holds blade guide assembly securely in mounting bracket. Loosen this bolt and one tilt bolt (L) to allow movement of the blade guide assembly in or out. Use a 1/2" wrench to loosen the jam nut and adjust the clamp bolt. |
| N | Blade Guide Stop Bolt - Provides a stop to prevent the guide assembly from getting pushed back during operation. Use a 1/2" wrench to loosen the jam nut and adjust the bolt until it touches the end of the blade guide shaft after adjusting blade guide assembly in/out. Retighten the jam nut. |

7.2.2 Preparing For Blade Guide Alignment

Recommended tools:

- Wrenches: 1/2", 9/16", 3/4", & 1"
 - 5/16" Nut Driver
 - 5/32" Hex Wrench
 - Blade Guide Alignment Blocks
 - Bottom Guide Block Adjustment Tool
 - Blade Guide Alignment Tool
 - Blade Guide Arm Alignment Tool
 - Flashlight
1. Remove the blade and replace the blade wheel belts. New blade wheel belts are required to perform the complete alignment procedure.
 2. Blow sawdust off of the blade guide assemblies. Remove sawdust from the blade housings.
 3. Remove the blade guide assemblies.

NOTE: To remove the blade guide assemblies and maintain the tilt adjustments, only loosen one side screw and the top screw. Leaving the other side screw and bottom screw in position will insure you will return the rollers to their original tilt adjustment.

4. Adjust the outer blade guide arm in or out until the outer blade guide is approximately 24" from the inner blade guide.
5. Install a new blade and apply the appropriate tension ([See Section 4.7](#)).
6. Close the blade housing covers and make sure all persons are clear of the saw head.
7. Start the engine (or motor).
8. Engage the blade, rotating the blade until the blade positions itself on the wheels.



WARNING! Do not spin the blade wheels by hand. Spinning the blade wheels by hand may result in serious injury.

9. Disengage the blade. Turn the engine off and remove the key.

7.2.3 Blade Wheel Vertical Alignment

1. Use the blade guide alignment tool to check the vertical alignment of each blade wheel. Attach the tool to the blade near the inner blade guide. Be sure the tool does not rest on a tooth or burr, and is lying flat on the bottom of the blade.

See Figure 7-10.

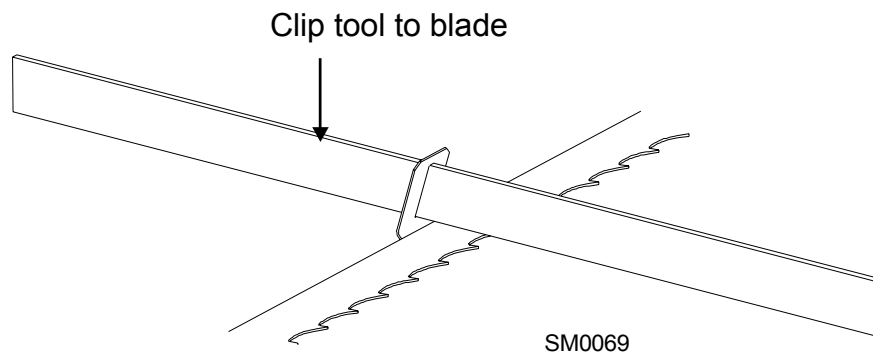

FIG. 7-10

2. Move the saw carriage so the front end of the tool is positioned over the first bed rail. Measure from the bottom of the tool to the top surface of the bed rail.
3. Move the saw carriage so the rear of the tool is positioned over the bed rail. Again, measure from the bottom of the tool to the bed rail.
4. If the two measurements are not equal within 1/16", adjust the vertical tilt of the drive-side blade wheel. Remove the drive-side cover and locate the vertical tilt adjustment bolts. Loosen the jam nuts on each bolt. Adjust the bolts down to tilt the blade up. Adjust the bolts up to tilt the blade down. Retighten the jam nuts and recheck the tilt of the blade with the blade guide alignment tool.

See Figure 7-11.

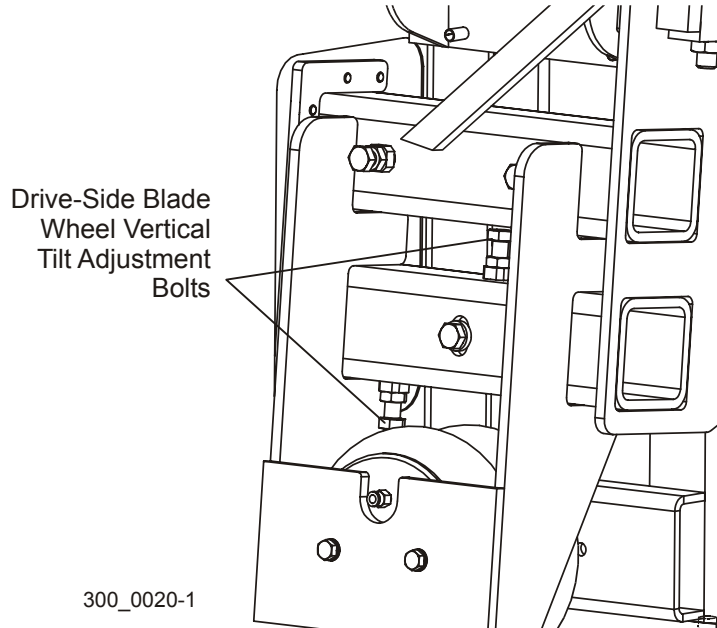

FIG. 7-11

5. Remove the tool from the blade and reattach it near the outer blade guide assembly.
6. Measure from the tool to the bed rail at both ends of the tool. If the measurements at the front and rear ends of the tool are not equal within 1/16", adjust the vertical tilt of the idle-side blade wheel. Loosen the jam nuts on each bolt. Adjust the bolts down to tilt the blade up. Adjust the bolts up to tilt the blade down. Retighten the jam nuts and recheck the tilt of the blade with the blade guide alignment tool.

See Figure 7-12.

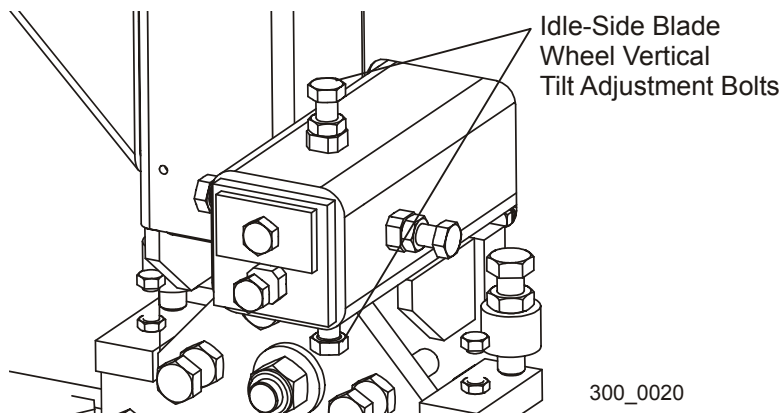

FIG. 7-12

7 Alignment

Blade Guide Arm Alignment

7.2.4 Blade Guide Arm Alignment

Adjust the blade guide arm all the way in toward the inner blade guide assembly.

See Figure 7-13. Attach the blade guide arm alignment tool to the blade guide arm, near the outer blade housing. Measure the distance from the back edge of the blade to the tool. Move the tool to the end of the arm near the blade guide. Measure again from the back edge of the blade to the tool. The two measurements at each end of the arm should be the same within 1/32". To adjust the horizontal tilt of the arm parallel to the blade, adjust the bolts (A & B) on the blade guide arm mounting plate. Loosen the jam nuts. Adjust bolt (A) out and bolt (B) in to move the arm away from the blade. Adjust bolt (B) out and bolt (A) in to move the arm toward the blade. Recheck the distance from the back edge of the blade to the tool at both ends of the arm. Readjust if necessary. Tighten the jam nuts.

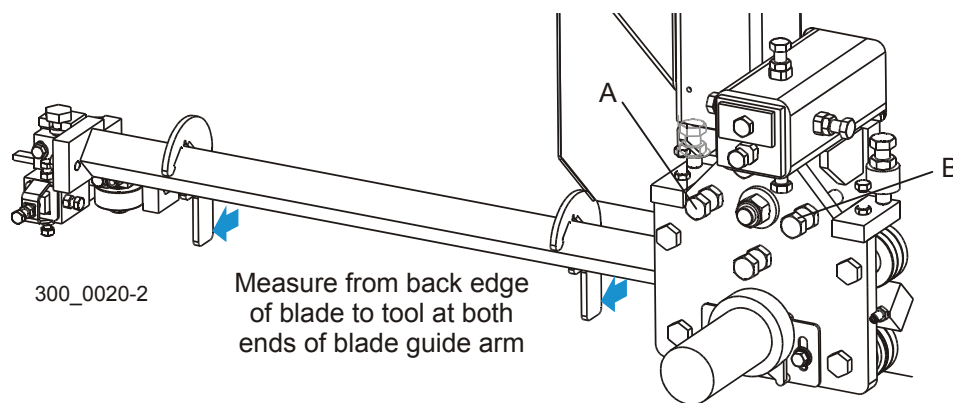

FIG. 7-13

See Figure 7-14. With the blade guide arm adjusted in near the inner blade guide, measure the distance from the top of the blade to the top blade guide block. Adjust the blade guide arm all the way out and measure again. If the two measurements are not equal with $1/32$ ", adjust the vertical tilt of the blade guide arm. To adjust the vertical tilt of the arm, adjust the bolts (C & D) on the blade guide arm mounting plate. Loosen the jam nuts. Adjust bolt (C) up and bolt (D) down to tilt the arm up. Adjust bolt (D) up and bolt (C) in to move the arm toward the blade. Recheck the distance from the blade to the top block at both ends of the arm. Readjust if necessary. Tighten the jam nuts.

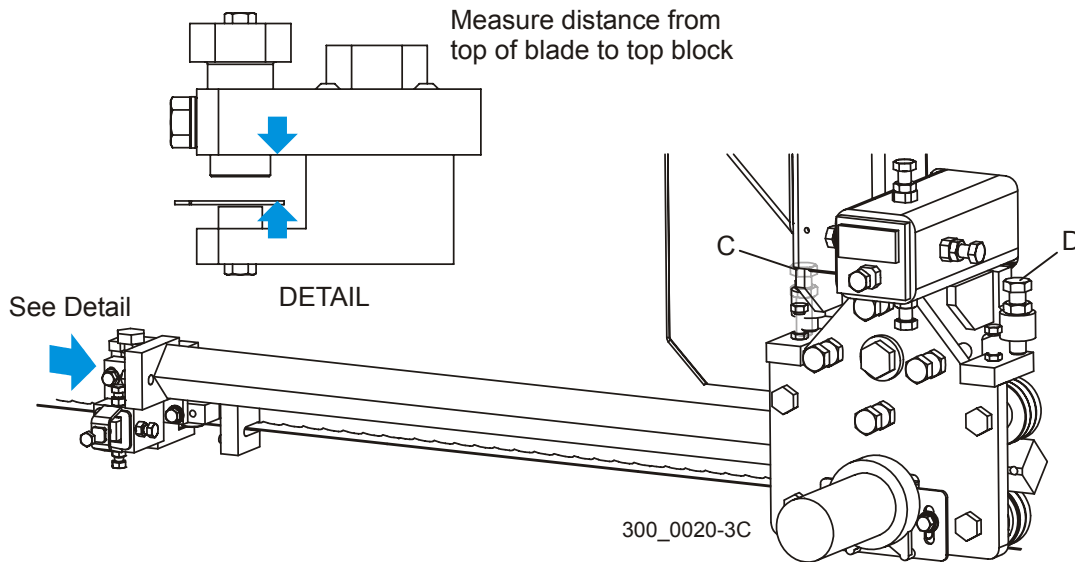

FIG. 7-14

7.2.5 Blade Guide Alignment

Each AWMV sawmill has two blade guide assemblies that help the blade maintain a straight cut. The two blade guide assemblies are positioned on the saw head to guide the blade on each side of the material being cut.

One blade guide assembly is mounted in a stationary position on the drive side of the saw head. This assembly is referred to as the "inner" blade guide assembly.

The other blade guide assembly is mounted on the idle side of the saw head. It is referred to as the "outer" assembly and is adjustable for various widths of materials to be processed.

NOTE: Before installing the blade guide assemblies, remove the blade guide adjusting screws and apply a lubricating oil such as 10W30 or Dexron III to each screw. This will prevent the screws and threaded holes from corroding and make screw adjustments easier.

1. Inspect the guide blocks and repair or replace as necessary. Remove the blade from the sawmill.

See Figure 7-6.

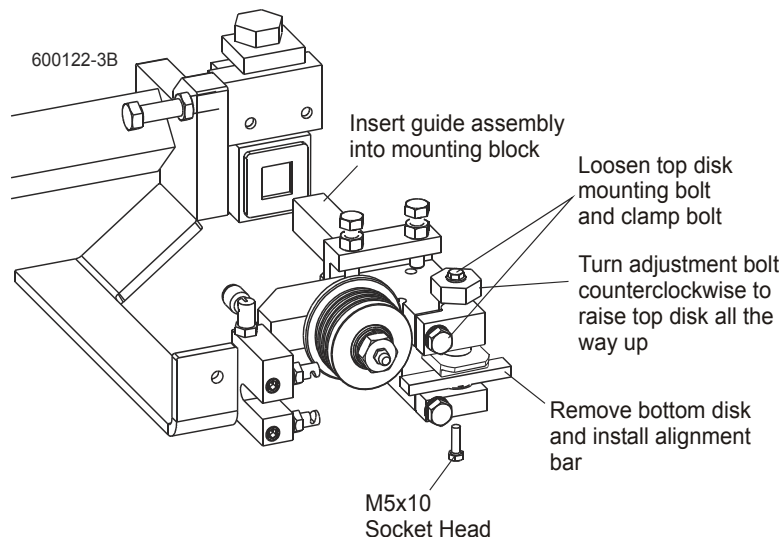

FIG. 7-6

2. Loosen the top block clamp bolt and mounting bolt. Turn the adjustment bolt counterclockwise to raise the top block all the way up. Remove the bottom guide block from each blade guide assembly and install the provided alignment bar.
3. Install each blade guide assembly to the mounting blocks and push all the way back.

4. Install, tension and track a new blade. Adjust the outer blade guide assembly so the roller flange is 1/5" (5mm) from the back of the blade. Adjust the inner blade guide assembly so the roller flange is 1/6" (4mm) from the blade.

See Figure 7-7. Tighten the two previously-loosened tilt adjustment screws to secure the blade guide assembly. Turn the top adjustment bolt clockwise to raise the blade guide assembly so the roller does not contact the blade.

NOTE: Before adjusting the top bolt, unload pressure on the bolt by turning 1/2 turn in the opposite direction it was last adjusted.

With the roller flange positioned properly from the back of the blade, adjust the stop bolt so it touches the end of the blade guide mounting shaft.

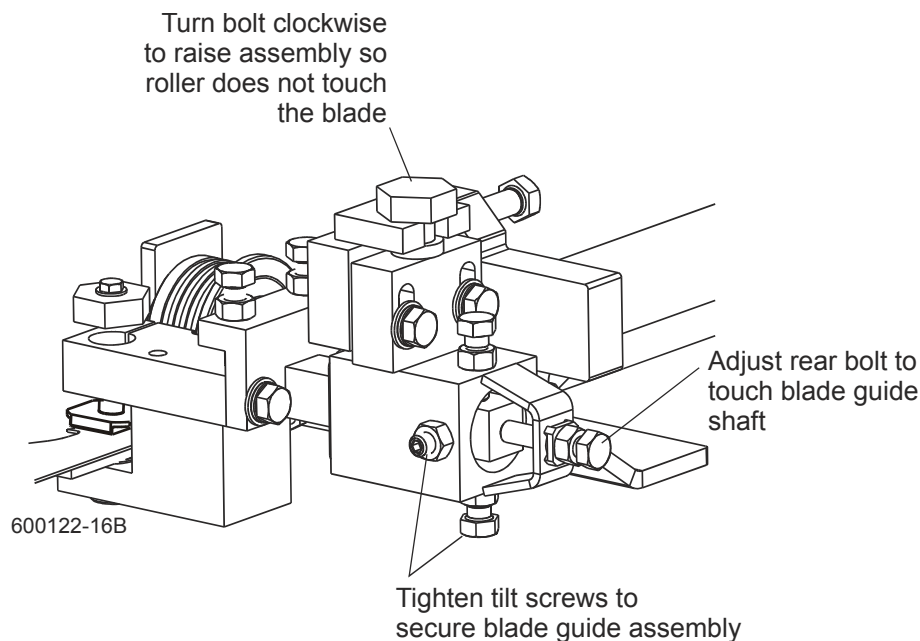

FIG. 7-7

Adjust the blade guide assemblies so the rollers deflect the blade down 1/4"

5. Raise the saw head until the blade is 15" (375 mm) above a bed rail. Measure the actual distance with a tape from the top of the rail to the bottom of the blade.

See Figure 7-8.

Turn the top adjustment bolt counterclockwise to lower the assembly until the blade guide roller deflects the blade down until the bottom of the blade measures 14 3/4" (370 mm)

7 Alignment

Blade Guide Alignment

from the bed rail.

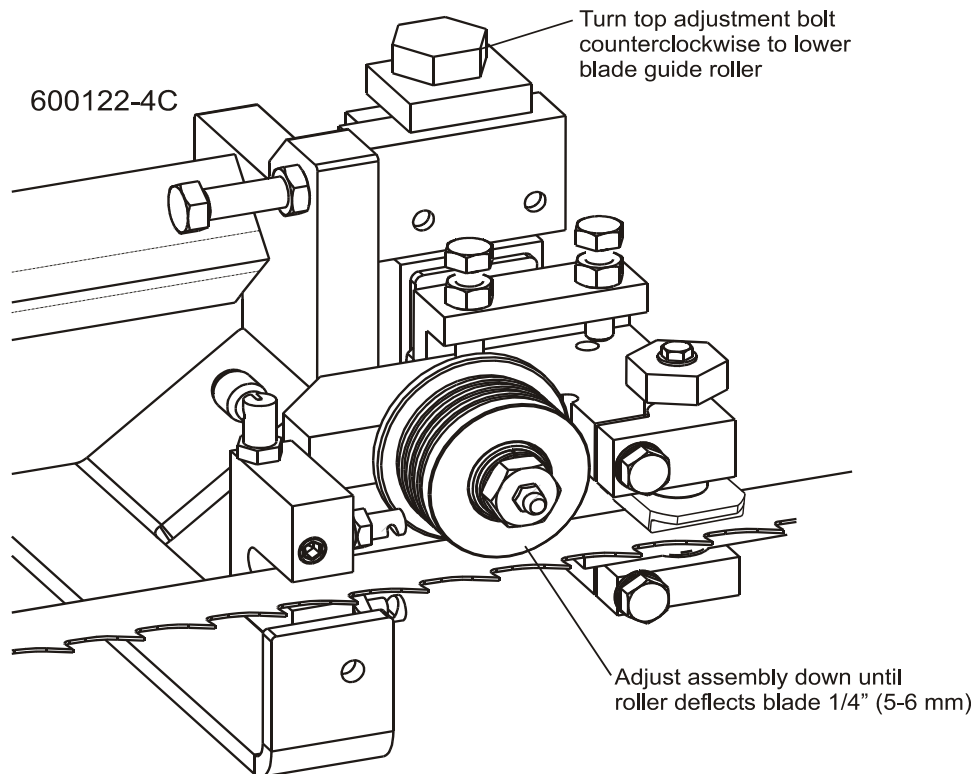

FIG. 7-8

NOTE: Before adjusting the top bolt, unload pressure on the bolt by turning 1/2 turn in the opposite direction it was last adjusted.

6. Repeat for the other blade guide.

Check the blade guides are adjusted properly in the vertical plane. If the blade guides are tilted vertically, the blade will try to travel in the tilted direction.

A Blade Guide Alignment Tool (BGAT) is provided to help you measure the vertical tilt of the blade.

7. Open the adjustable blade guide arm 1/2" (15 mm) from full open.
8. Clamp the alignment tool on the blade. Position the tool close to the outer blade guide roller. Be sure the tool does not rest on a tooth or burr, and is lying flat on the blade.

See Figure 7-9.

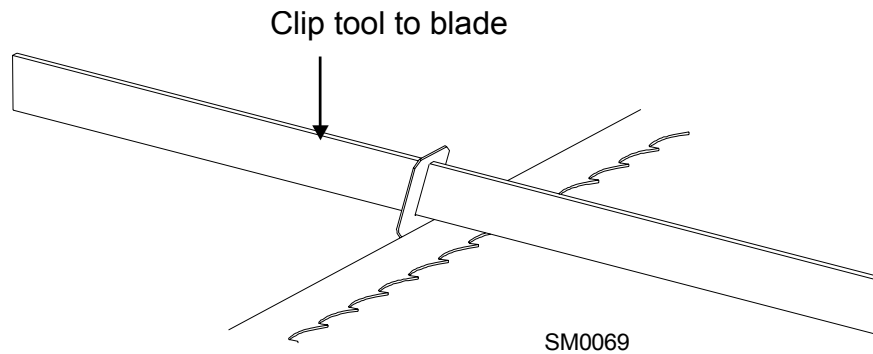

FIG. 7-9

9. Move the carriage so that the front end of the tool is positioned above the bed rail. Measure the distance from the bed rail to the bottom edge of the tool.
10. Move the carriage so that the back end of the tool is positioned above the bed rail. Measure the distance from the bed rail to the bottom edge of the tool.
11. If the measurement from the tool to the bed rail is not equal within $1/32"$ (.75 mm), adjust the vertical tilt of the outer blade guide roller.
12. Loosen one set screw at the side of the blade guide assembly.

7

Alignment

Blade Guide Alignment

See **Figure 7-10**. Loosen the jam nuts on the top and bottom vertical tilt adjustment screws. To tilt the roller up, loosen the bottom screw and tighten top screw. To tilt the roller down, loosen the top screw and tighten the bottom screw. Tighten the jam nuts and recheck the tilt of the blade.

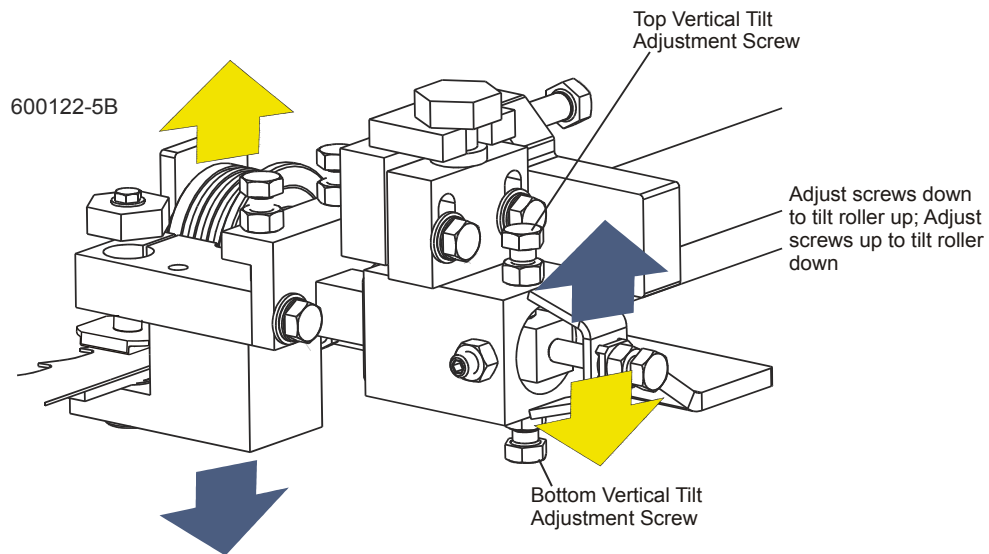

FIG. 7-10

13. Move the blade guide alignment tool close to the inner blade guide roller assembly and repeat the above steps. Adjust the vertical tilt of the inner blade guide if necessary.
14. After adjusting the vertical tilt of the blade guides, recheck the blade deflection and adjust if necessary.

If the blade guides are tilted in the wrong direction horizontally, the back of the blade may contact the flange as the roller is spinning down, causing it to push the blade away from the guide roller.

15. Remove the blade guide alignment tool from the blade and adjust the blade guide arm halfway in.
16. Remove the clip from the blade guide alignment tool. Place the tool against the face of the outer blade guide roller.

See Figure 7-11.

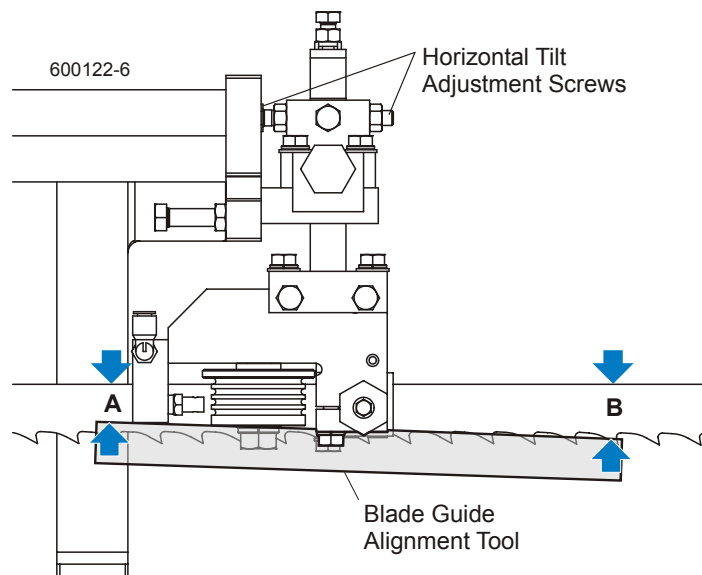

FIG 7-11

17. Measure between the back edge of the blade and the tool at the end closest to the inner blade guide ("B").
18. Measure between the back edge of the blade and the other end of the tool ("A").

The roller should be tilted slightly to the left ('A' 1/8" [3 mm] less than 'B' $\pm 1/8$ " [3 mm]).

See Figure 7-12. Loosen the jam nuts on the horizontal tilt adjustment screws. To tilt the roller left, loosen the right screw and tighten left screw. To tilt the roller right, loosen the left screw and tighten the right screw. Tighten the jam nuts and recheck the tilt of the blade.

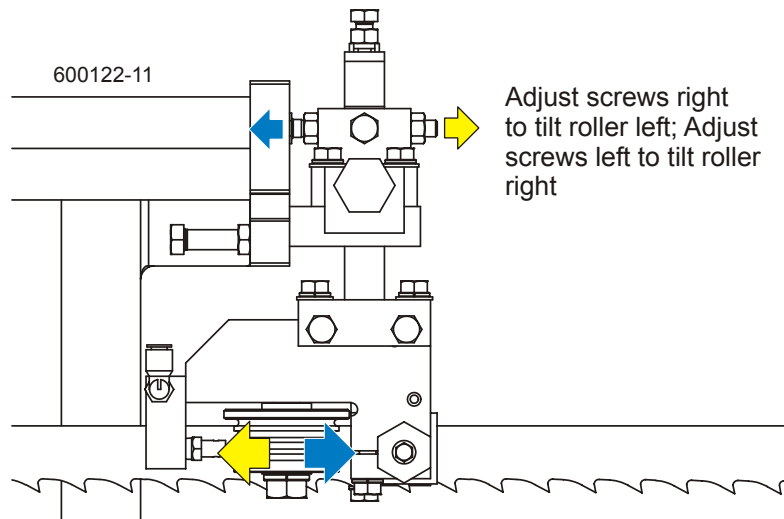

FIG. 7-12

19. Repeat the above steps for the inner blade guide roller assembly.

NOTE: Once the blade guides have been adjusted, any cutting variances are most likely caused by the blade. [See *Blade Handbook, Form #600.*](#)

Each blade guide must be adjusted so the roller flange is the correct distance from the back edge of the blade. If the flange is too close to or too far from the blade, the sawmill will not cut accurately.

HINT: When adjusting blade guide spacing, loosen the top set screw and one side set screw only. This will ensure horizontal and vertical tilt adjustments are maintained when the adjustment screws are retightened.

20. Measure the distance between the flange on the inner blade guide roller to the back edge of the blade. This distance should measure 1/6" (4 mm). Adjust the roller back or forward if necessary.

See Figure 7-13. Loosen the top and one side screw shown. Back the stop bolt out of the way if necessary. Tap the blade guide forward or backward until properly positioned. Retighten the screws and jam nuts. Adjust the stop bolt against the blade guide assembly.

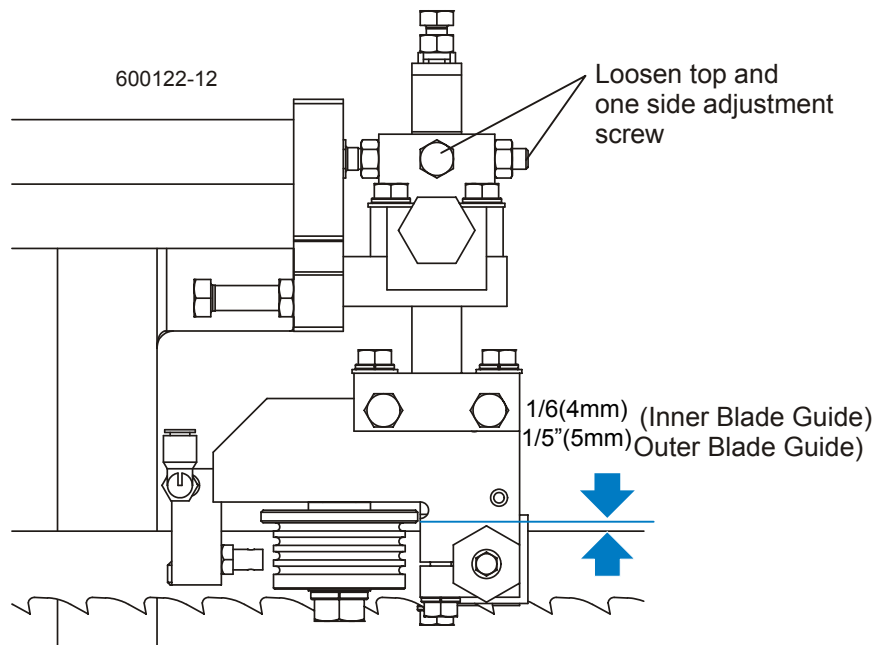

FIG. 7-13

21. Measure the distance between the flange on the outer blade guide roller to the back edge of the blade. This distance should measure 1/5" (5.0 mm). Adjust the roller back or forward if necessary.

7

Alignment

Blade Guide Alignment

Perform the following adjustments to make sure the blade guide assembly is parallel to the blade.

22. Loosen the alignment bar mounting bolt. Use the provided bottom block adjustment tool to adjust the alignment bar up so the bar is close to, but not touching the bottom of the blade. Retighten the alignment bar mounting bolt
23. Check that the gap from the alignment bar to the blade is the same along entire length of the bar. Shine a flashlight behind the blade guide assembly to help you see the gap between the bar and the blade.

To adjust, loosen the rear clamp bolts, but leave snug. Determine which outer bolt to use to tilt the blade guide assembly as desired. Loosen the jam nut and turn the bolt until the alignment bar is parallel to the blade. Retighten the jam nut and clamp bolts. Repeat for the second blade guide assembly.

See Figure 7-14.

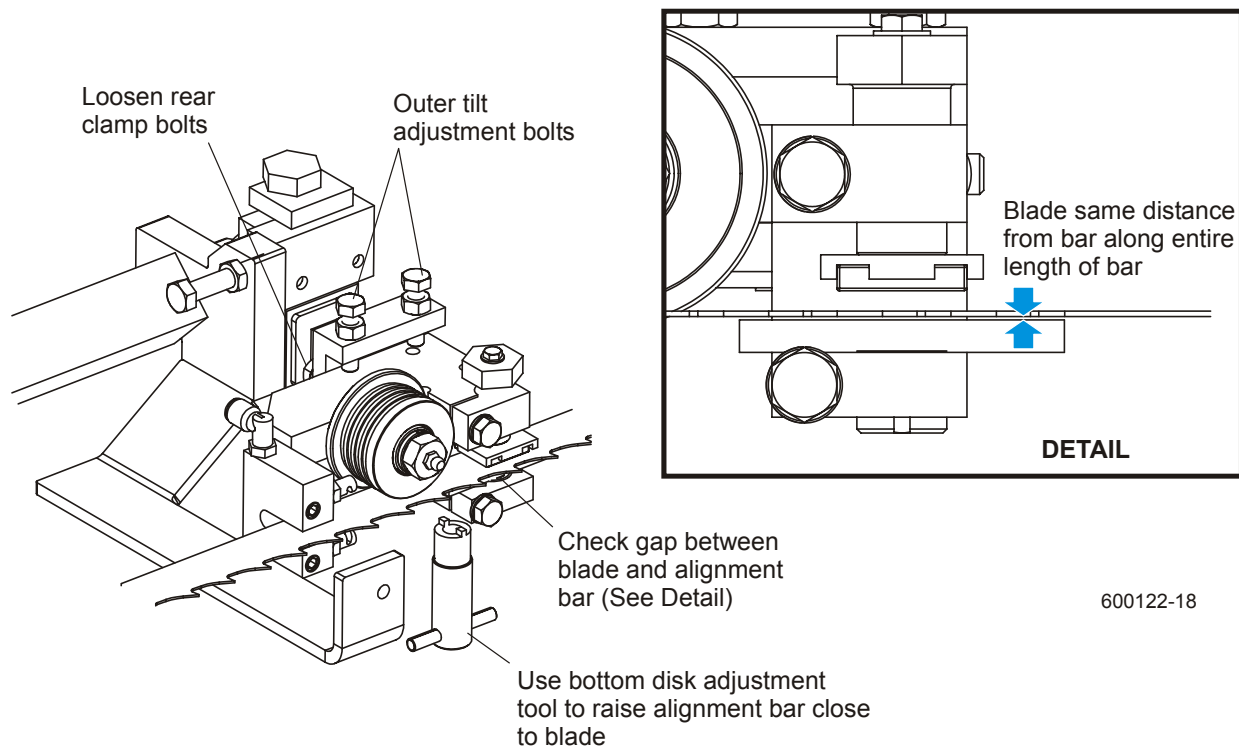

600122-18

FIG. 7-14

Adjust the blade guide blocks the proper distance from the blade.

- 24.** Remove the blade and remove the alignment bars from the blade guide assemblies. Install new or reconditioned bottom guide blocks to both blade guide assemblies (leave mounting bolts loose). Use the provided bottom block adjustment tool to lower the bottom block all the way down. Install, tension and track the blade.

See Figure 7-15.

- 25.** Use the bottom block adjustment tool to raise the bottom block to .02" (0,5mm) from the

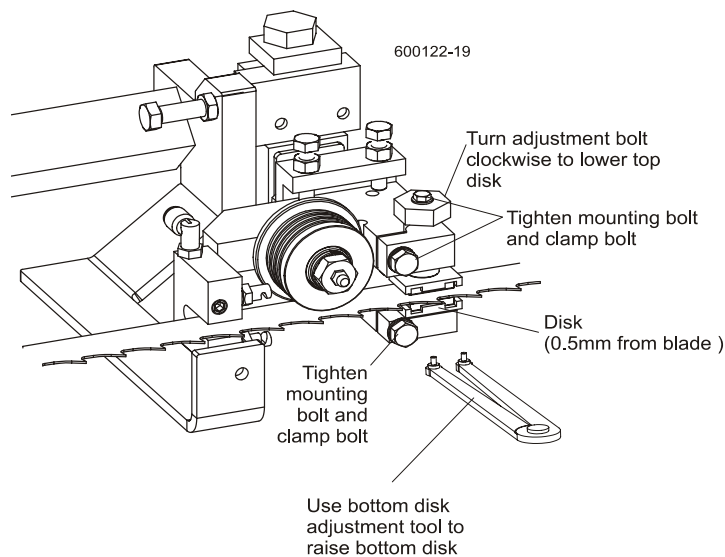

FIG. 7-15

blade. Use the provided shim to set the distance from the block to the blade. Tighten the bottom block mounting bolt and clamp bolt.

- 26.** Turn the top block adjustment bolt clockwise to lower the top block to .008" - .010" (0,2-0,25mm) from the blade (using the shim as a guide). Tighten the top block mounting bolt and clamp bolt.
- 27.** After tightening the clamp bolt, recheck the distance from the top block to the blade and readjust if necessary.

7.3 Blade Guides (Optional Block Guides)

NOTE: Block Guides are optional on the LT300. [See Section 7.2](#) for standard Block/Roller Guide alignment.



WARNING! Blade guide alignment is essential for optimal cutting performance, blade life and safety. Failure to check and maintain proper blade guide alignment will result in stress cracks forming in the blade. These cracks will lead to premature blade breakage. If the blade breaks during operation and the blade has multiple stress cracks, the blade could shatter into several pieces and escape from the protective guards of the sawmill. Small blade pieces projected into the area around the sawmill creates a safety hazard for the operator and any bystanders surrounding the mill.

WARNING! DO NOT use blades with stress cracks. Blades with stress cracks can shatter causing bodily injury and/or machine damage.

7.3.1 Blade Guide Adjustment Overview

Proper blade guide alignment is critical to optimum machine performance. It is important to understand and follow the procedures in this section to properly align the blade guides.

See Figure 7-15. The major components of the blade guide assemblies are the top and bottom guide blocks and guide roller.

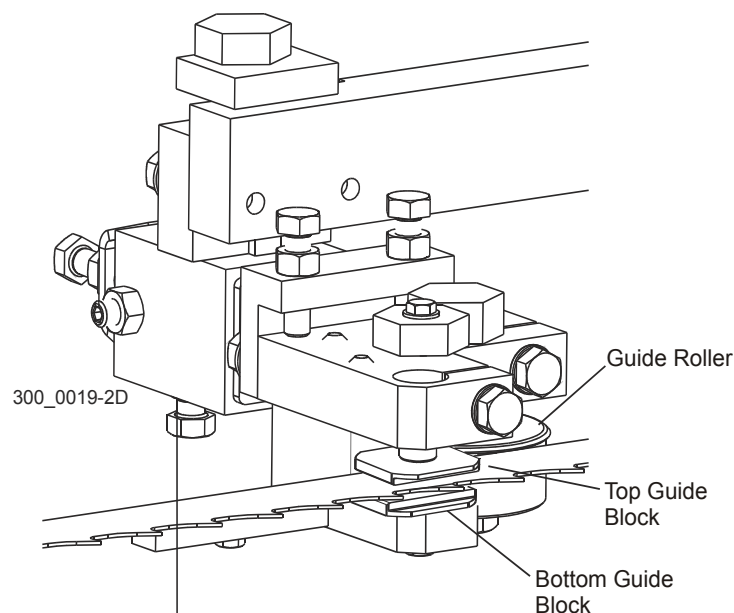

FIG. 7-15

See **Figure 7-16**. The objective to aligning the blades guides is to properly position the guide blocks and guide roller in relation to the blade. The blocks should be aligned with the back edge of the blade as viewed from the top. They must also be parallel to the blade as viewed from the front. The roller should be $1/16'' - 1/8''$ from the back edge of the blade.

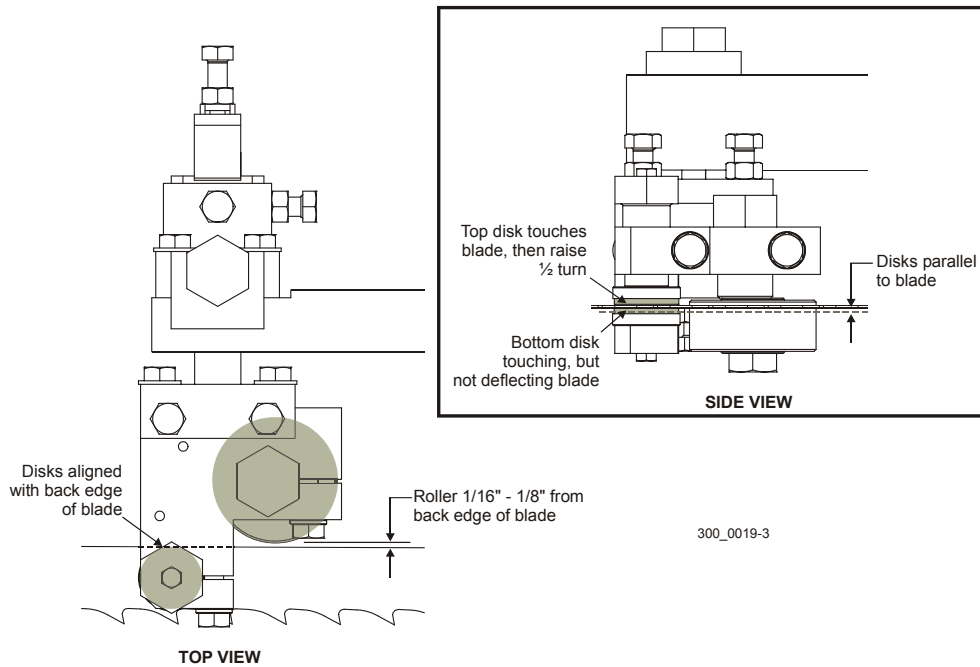

FIG. 7-16

7 Alignment

Blade Guide Adjustment Overview

See Figure 7-17. Adjustment bolts are provided to obtain the proper blade guide alignment. The various blade guide adjustments are described below.

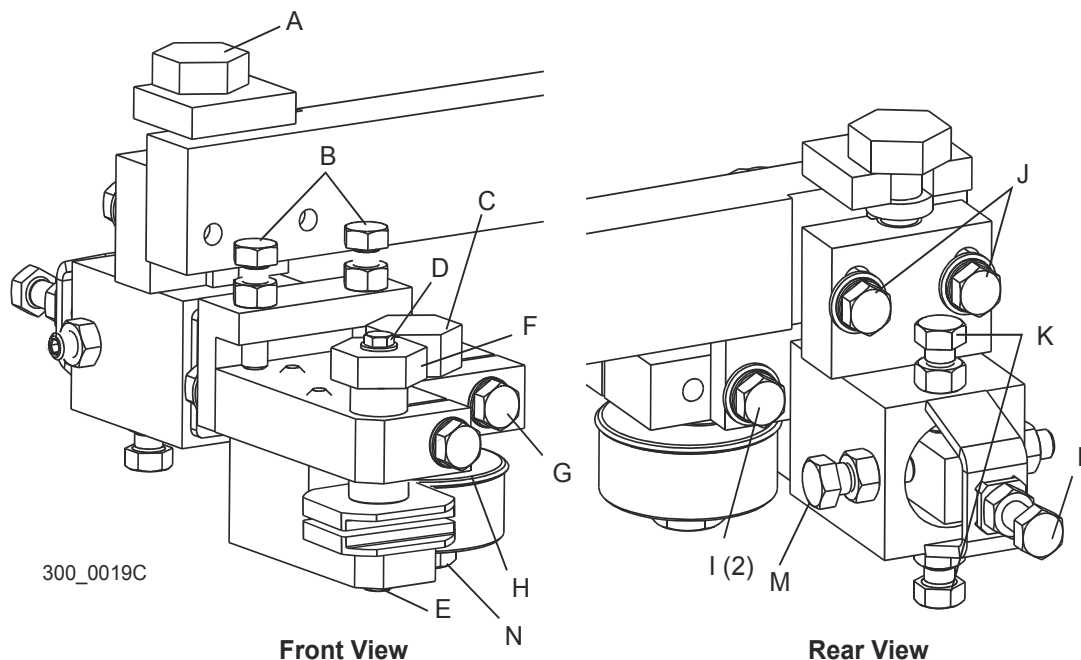

FIG. 7-17

| | |
|----------|---|
| A | Vertical Adjustment Bolt - Use to adjust entire blade guide assembly up or down. Use a 1" wrench to turn the bolt. Turning clockwise will raise assembly; counterclockwise will lower assembly. This adjustment may be made without loosening clamp bolts (J) if assembly is properly lubricated. |
| B | Guide Tilt Bolts - Use to adjust the bolts to tilt the blade guides so the guide blocks are parallel to the blade. Loosen clamp bolts (I), but leave them snug. To adjust each bolt, use a 1/2" wrench to loosen the jam nut, adjust the bolt and retighten the jam nut. Retighten clamp bolts (I). |
| C | Roller Adjustment Bolt - Use to move guide roller toward or away from the blade or to adjust the roller up or down as the blade wears a groove in the roller. Use a 1/2" wrench to loosen clamp bolt (G) and turn roller adjustment bolt by hand to move roller toward or away from blade. Retighten clamp bolt (G). |
| D | Top Guide Block Bolt - Use to disassemble top guide block. Use 5/16" nut driver to remove bolt. |
| E | Bottom Guide Block Bolt - Use to disassemble bottom guide block. Use 5/16" nut driver to remove bolt. |
| F | Top Guide Block Adjustment Bolt - Use to raise or lower top guide block. Use a 1/2" wrench to loosen clamp bolt (H) and turn by hand. Turn adjustment bolt by hand counterclockwise to raise top guide block; clockwise to lower top guide block. |
| G | Roller Clamp Bolt - Loosen with 1/2" wrench to allow adjustment of roller adjustment bolt (C). |

| | |
|----------|---|
| H | Top Guide Block Clamp Bolt - Loosen with 1/2" wrench to allow adjustment of top guide block adjustment bolt (E). |
| I | Guide Block Clamp Bolts - Loosen both bolts but leave snug with 1/2" wrench to allow adjustment of guide tilt bolts (B). |
| J | Blade Guide Assembly Clamp Bolts - Used to secure vertical adjustment of entire blade guide assembly. Loosening these bolts is not normally required when adjusting the vertical adjustment bolt (A). Make sure these bolts are tight after making vertical adjustment. |
| K | Vertical Tilt Adjustment Bolts - Use the bolts to tilt the entire blade so it is parallel to the bed rails. Use a 1/2" wrench to loosen the jam nuts. Adjust the bolts up to tilt the blade down; adjust bolts down to tilt blade up. Retighten the jam nuts. |
| L | Blade Guide Stop Bolt - Provides a stop to prevent the guide assembly from getting pushed back during operation. Use a 1/2" wrench to loosen the jam nut and adjust the bolt until it touches the end of the blade guide shaft after adjusting blade guide assembly in/out. Retighten the jam nut. |
| M | Blade Guide Clamp Bolt - Holds blade guide assembly securely in mounting bracket. Loosen this bolt and one tilt bolt (K) to allow movement of the blade guide assembly in or out. Use a 1/2" wrench to loosen the jam nut and adjust the clamp bolt. |
| N | Roller Mount Bolt - Remove this bolt to flip or replace the roller. Once the top half of the roller is worn, remove the bolt and flip the roller so the worn half is on the bottom. |

7.3.2 Preparing For Blade Guide Alignment

Recommended tools:

- Wrenches: 1/2", 3/4", & 1"
 - 5/16" Nut Driver
 - Blade Guide Alignment Blocks
 - Blade Guide Alignment Tool
 - Blade Guide Arm Alignment Tool
 - Flashlight
1. Remove the blade from the sawmill. Blow sawdust off of the blade guide assemblies. Remove sawdust from the blade housings. Scrape any sawdust buildup from the blade wheel rims. If sawdust buildup is present on the wheels, perform the wheel scraper inspection and maintenance as described in [Section 5.8](#).
 2. Adjust the outer blade guide arm in or out until the outer blade guide is approximately 24" from the inner blade guide.

See Figure 7-18. At both blade guide assemblies, loosen clamp bolt (H) and turn bolt (F) counterclockwise to raise the top guide block all the way up. Remove bolt (N) and remove the guide roller and roller cover from each blade guide assembly.

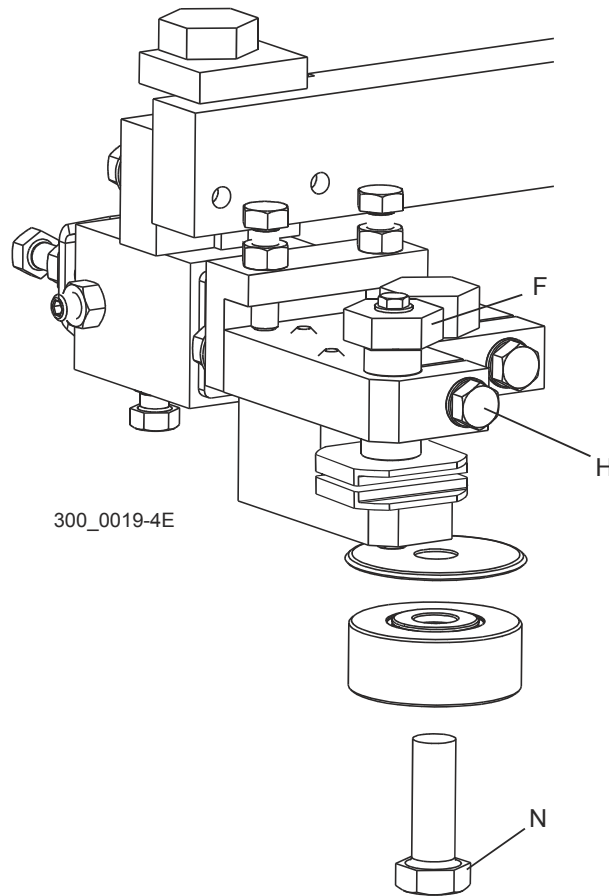

FIG. 7-18

3. Remove the bottom guide blocks from both blade guide assemblies.
4. Install, tension and track a new blade on the blade wheels ([See Section 4.7](#)).

NOTE: The blade tension **MUST** be released when adjusting the blade wheels to track the blade.

7 Alignment

Preparing For Blade Guide Alignment

5. Install the provided alignment blocks to the blade guide assemblies where the bottom guide blocks were. Use the longer bolt provided with the alignment block.

See Figure 7-19.

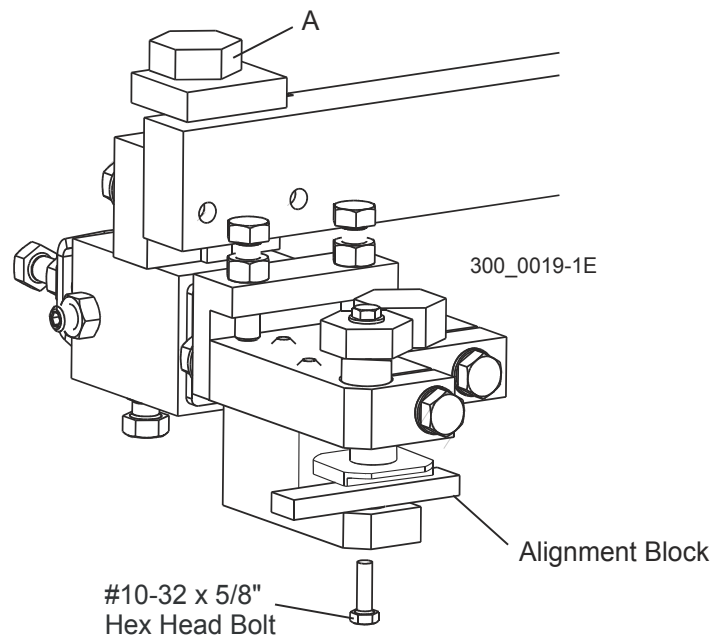

FIG. 7-19

6. Adjust the blade guides so the alignment blocks do not contact the blade. Turn bolt (A) counterclockwise to lower the blade guide assembly until the alignment block does not touch the blade.

NOTE: Before adjusting the top bolt, unload pressure on the bolt by turning 1/2 turn in the opposite direction it was last adjusted.

7.3.3 Blade Wheel Vertical Alignment

1. Use the blade guide alignment tool to check the vertical alignment of each blade wheel. Attach the tool to the blade near the inner blade guide. Be sure the tool does not rest on a tooth or burr, and is lying flat on the bottom of the blade.

See Figure 7-20.

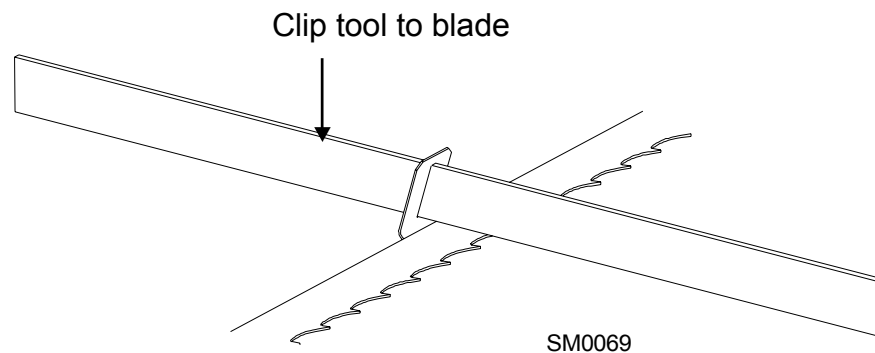

FIG. 7-20

2. Move the saw carriage so the front end of the tool is positioned over the first bed rail. Measure from the bottom of the tool to the top surface of the bed rail.
3. Move the saw carriage so the rear of the tool is positioned over the bed rail. Again, measure from the bottom of the tool to the bed rail.
4. If the two measurements are not equal within 1/16", adjust the vertical tilt of the drive-side blade wheel. Remove the drive-side cover and locate the vertical tilt adjustment bolts. Loosen the jam nuts on each bolt. Adjust the bolts down to tilt the blade up. Adjust the bolts up to tilt the blade down. Retighten the jam nuts and recheck the tilt of the blade with the blade guide alignment tool.

7 Alignment

Blade Wheel Vertical Alignment

See Figure 7-21.

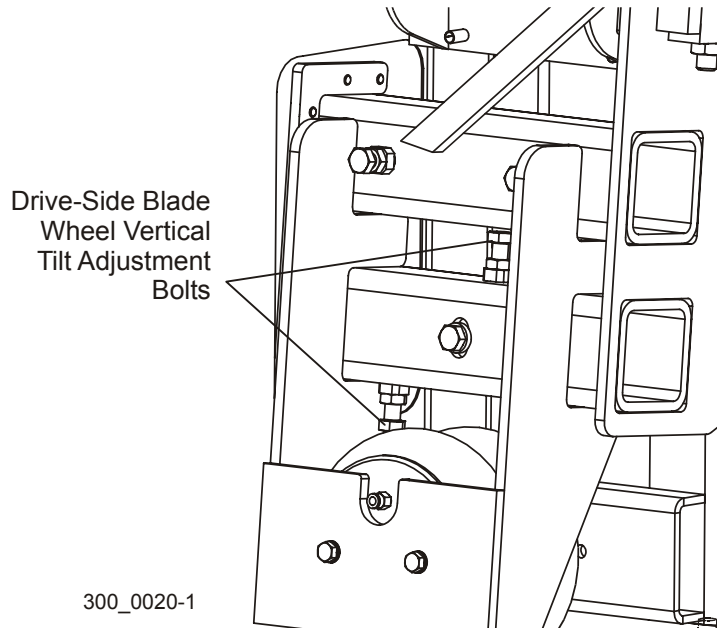

FIG. 7-21

5. Remove the tool from the blade and reattach it near the outer blade guide assembly.
6. Measure from the tool to the bed rail at both ends of the tool. If the measurements at the front and rear ends of the tool are not equal within 1/16", adjust the vertical tilt of the idle-side blade wheel. Loosen the jam nuts on each bolt. Adjust the bolts down to tilt the blade up. Adjust the bolts up to tilt the blade down. Retighten the jam nuts and recheck the tilt of the blade with the blade guide alignment tool.

See Figure 7-22.

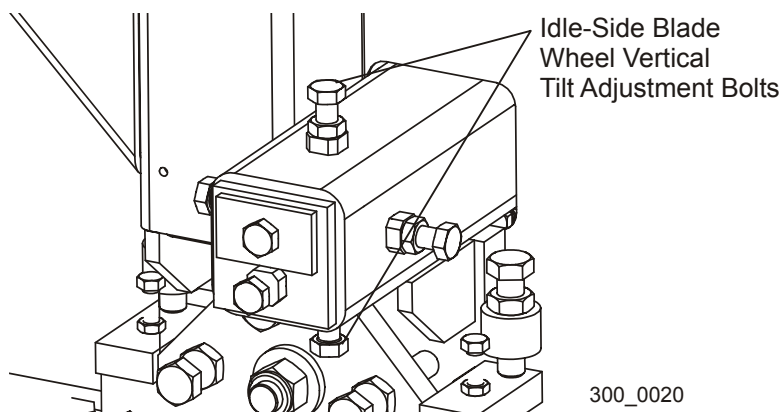

FIG. 7-22

7.3.4 Blade Guide Arm Alignment

Adjust the blade guide arm all the way in toward the inner blade guide assembly.

See Figure 7-23. Attach the blade guide arm alignment tool to the blade guide arm, near the outer blade housing. Measure the distance from the back edge of the blade to the tool. Move the tool to the end of the arm near the blade guide. Measure again from the back edge of the blade to the tool. The two measurements at each end of the arm should be the same within 1/32". To adjust the horizontal tilt of the arm parallel to the blade, adjust the bolts (A & B) on the blade guide arm mounting plate. Loosen the jam nuts. Adjust bolt (A) out and bolt (B) in to move the arm away from the blade. Adjust bolt (B) out and bolt (A) in to move the arm toward the blade. Recheck the distance from the back edge of the blade to the tool at both ends of the arm. Readjust if necessary. Tighten the jam nuts.

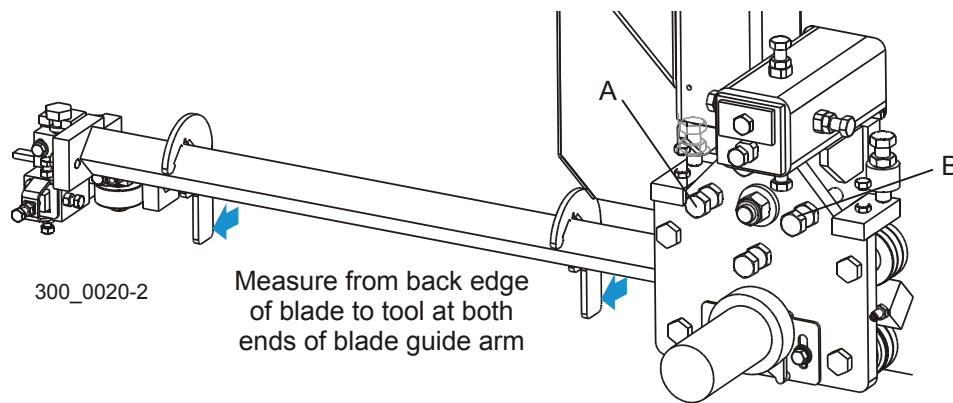

FIG. 7-23

7

Alignment

Blade Guide Arm Alignment

See Figure 7-24. With the blade guide arm adjusted in near the inner blade guide, measure the distance from the top of the blade to the top blade guide block. Adjust the blade guide arm all the way out and measure again. If the two measurements are not equal with $1/32$ ", adjust the vertical tilt of the blade guide arm. To adjust the vertical tilt of the arm, adjust the bolts (C & D) on the blade guide arm mounting plate. Loosen the jam nuts. Adjust bolt (C) up and bolt (D) down to tilt the arm up. Adjust bolt (D) up and bolt (C) in to move the arm toward the blade. Recheck the distance from the blade to the top block at both ends of the arm. Readjust if necessary. Tighten the jam nuts.

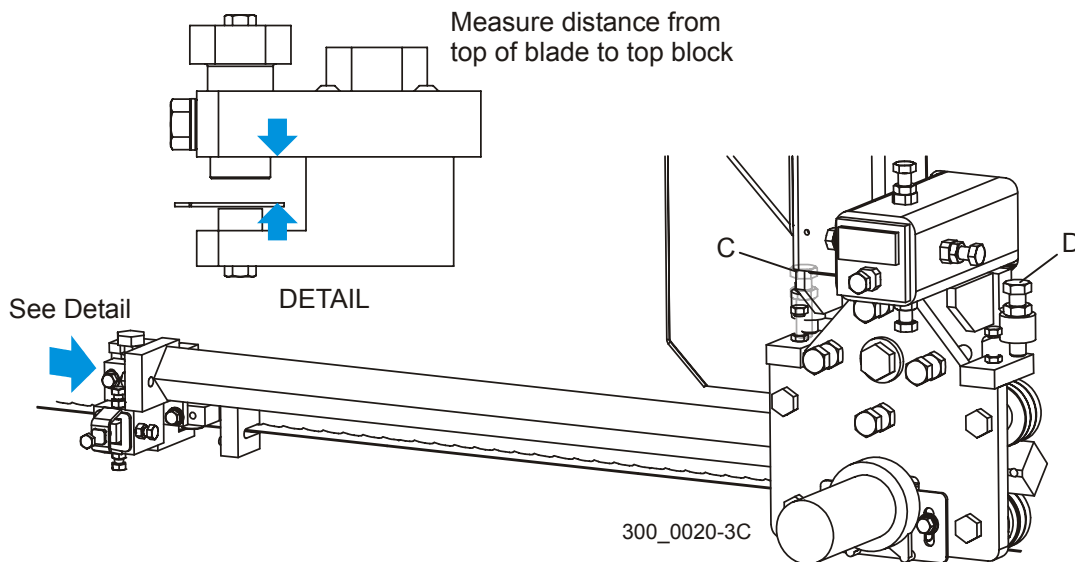

FIG. 7-24

7.3.5 Blade Guide Alignment

1. Check that the alignment blocks are parallel to the blade. Adjust bolt (A) to raise the blade guide assembly until the block almost touches the blade.

NOTE: Before adjusting the top bolt, unload pressure on the bolt by turning 1/2 turn in the opposite direction it was last adjusted.

2. Check that the gap from the alignment block to the blade is the same along entire length of the block. Shining a flashlight behind the blade guide assembly will help you to see the gap between the block and the blade. To adjust, loosen clamp bolts (I), but leave snug. Determine which bolt (B) to use to tilt the blade guide assembly as desired. Loosen the jam nut and turn the bolt until the alignment block is parallel to the blade. Retighten the jam nut and clamp bolts (I). Repeat for the second blade guide assembly.

See Figure 7-25.

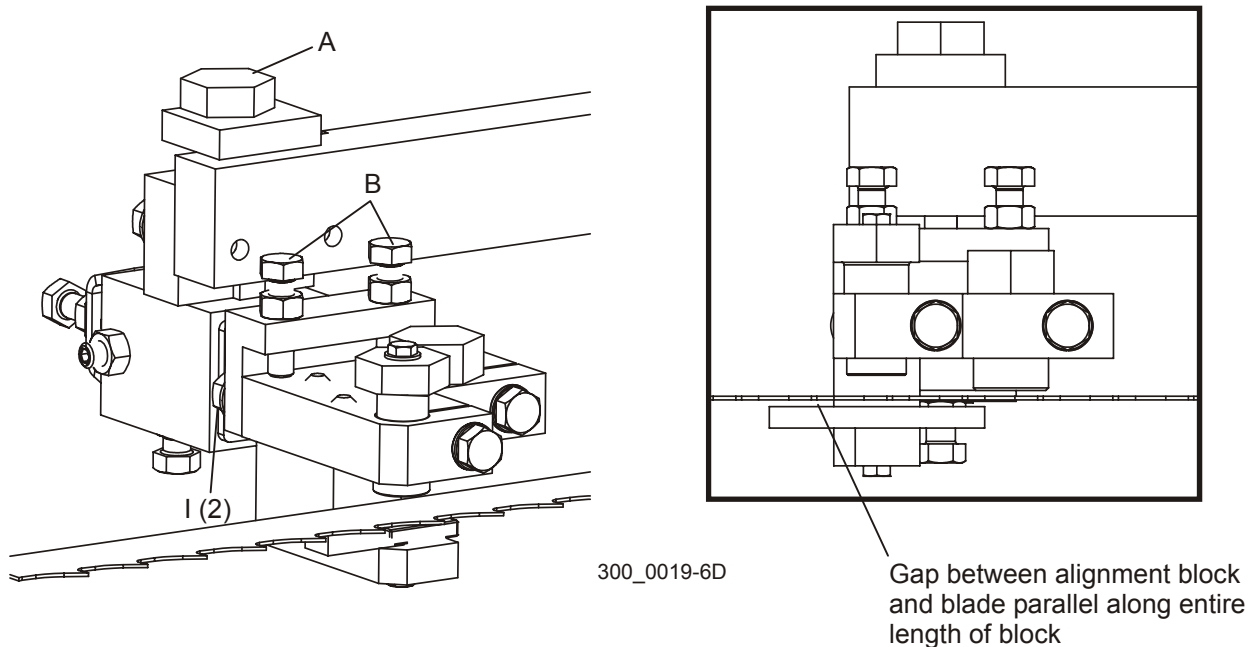

FIG. 7-25

3. Remove tension from the blade and remove the alignment blocks from the blade guide assemblies. Install new or reconditioned bottom guide blocks to both blade guide assemblies. Tension and track the blade.

4. Turn bolt (A) counterclockwise to adjust each blade guide assembly down until the bottom guide block is .008" - .010" from the blade.

See Figure 7-26.

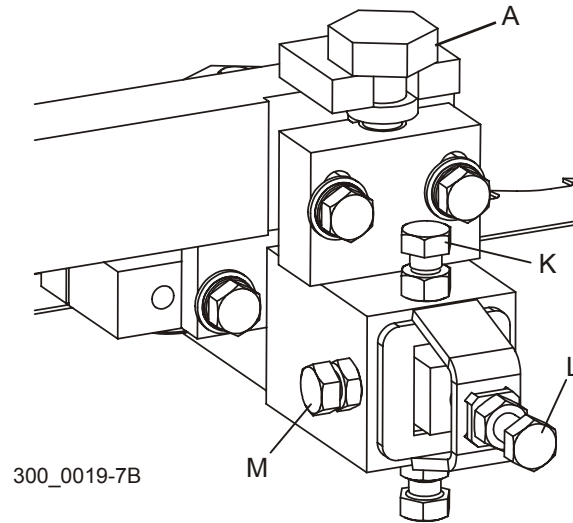

FIG. 7-26

5. Install new or reconditioned top guide blocks and check the position of the guide blocks in relation to the blade. The back of the blocks should be aligned with the back edge of the blade. To adjust, loosen one bolt (K) and bolt (M). Slide the blade guide assembly in or out as necessary. Loosen the jam nut on bolt (L) and adjust the bolt until it contacts the end of the blade guide shaft. Retighten the jam nut.
6. Turn bolt (F) clockwise to adjust the top guide block down until the blade is firmly clamped between the guide blocks. Tighten clamp bolt (H).
7. Check the tilt of each blade guide assembly using the blade guide alignment tool. Attach the tool to the blade near the inner blade guide. Be sure the tool does not rest on a tooth or burr, and is lying flat against the bottom of the blade.
8. Move the saw carriage so the front end of the tool is positioned over the first bed rail. Measure from the bottom of the tool to the top surface of the bed rail.
9. Move the saw carriage so the rear of the tool is positioned over the bed rail. Again, measure from the bottom of the tool to the bed rail.

10. If the two measurements are not equal within $1/32$ " , adjust the vertical tilt of the inner blade guide assembly. Loosen the jam nuts on bolts (K). Adjust the bolts up to tilt the blade down. Adjust the bolts down to tilt the blade up. Retighten the jam nuts and recheck the tilt of the inner blade guide assembly with the blade guide alignment tool.

See Figure 7-27.

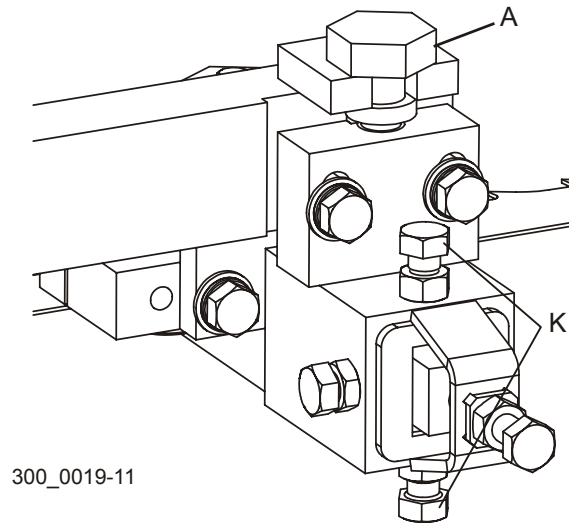

FIG. 7-27

11. Remove the tool from the blade and reattach it near the outer blade guide assembly.
12. Measure from the tool to the bed rail at both ends of the tool. If the measurements at the front and rear ends of the tool are not equal within $1/32$ " , adjust the vertical tilt of the outer blade guide assembly using bolts (K) as described above.
13. Loosen clamp bolt (H) and turn bolt (F) counterclockwise to raise the top guide block on each blade guide assembly until it is $.008$ " - $.010$ " from the blade. Tighten clamp bolt (H).

14. Reinstall the blade guide roller, roller cover and bolt (N). Install the roller upside down if the top half is worn with blade grooves. Use a new roller if both halves of the old roller are worn.
15. Check that each guide roller is $1/8$ " from the back edge of the blade. To adjust, loosen clamp bolt (G) and turn bolt (C) to move roller toward or away from blade. Raise or lower the roller to avoid the blade contacting an existing groove in the roller. Retighten clamp bolt (G).

See Figure 7-28.

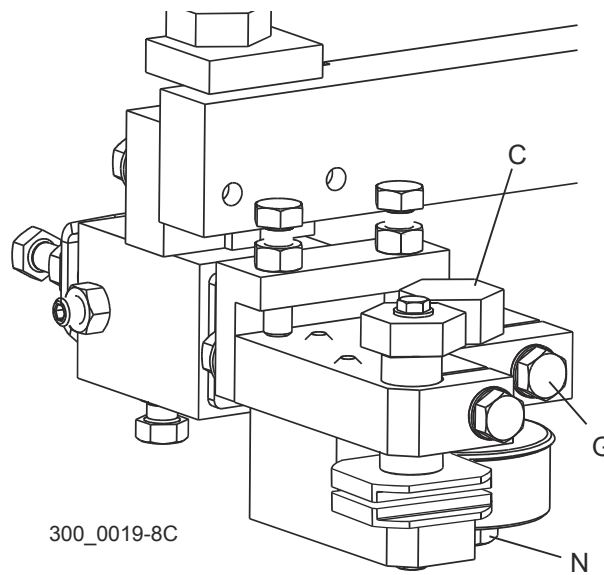

FIG. 7-28

SECTION 8 SPECIFICATION

8.1 Overall Dimensions

See Table 8-1. The overall dimensions of the LT300 are listed below.

| | |
|---|--------|
| Length (without control station) | 7,9m |
| Length (w/control and 0,8m between) | 9,4 |
| Width | 2,9m |
| Height (Max Head Position) | 2,7m |
| Sawmill Weight | 2540kg |
| Operator Station Weight (No Cab/Air Condition Options) | 471kg |
| Cab Option Weight | 344kg |
| Air Condition Option Weight | 43kg |
| Transfer Deck Option Weight | 958kg |
| Log Infeed Deck Option Weight (3,6m) | 789kg |
| Log Infeed Deck Option Weight (6,1m) | 1054kg |
| Incline Conveyor Option Weight | 635 |

TABLE 8-1

8.2 Motor Specifications

See Table 8-2. The power options available for the LT300 sawmills are listed below.

| Engine/Motor Type | Manufacturer | Model No. | Power | Other Specifications |
|----------------------------------|-----------------------|------------------|--------------|-----------------------------|
| 30HP Electric Motor ¹ | Indukta SA, Poland | Sg 180L-4 | 22kW | 1465 RPM |

TABLE 8-2

¹The electric motors supplied on Wood-Mizer sawmills carry a rating assigned by the motor manufacturer for the continuous duty operation of the motor, potentially, 24 hours per day, day after day. This rating is useful in sizing motors for use in applications like blowers for heating and ventilation that are never cycled off except for system maintenance.

See Table 8-3. The noise level of the LT300 sawmill is listed below. ***

| | |
|---|---------------------------------|
| | Engaged |
| Sawmill Equipped With Electric Motor | $L_{EX8} = 82,9 \text{ dB (A)}$ |

TABLE 8-3

8.3 Blade Specifications

See Table 8-4. The blades available for the LT300 sawmills are listed below.

| Blade Type | Manufacturer |
|----------------------|--------------|
| B476 488 B576 486 | Wood-Mizer |

TABLE 8-4

8.4 Dust Extractor Specifications

See Table 8-1. Specifications of the dust extractors.

| | |
|---|-----------------------|
| Airflow | 2300m ³ /h |
| Inlet diameter | 150mm |
| Motor power | 3kW |
| Number of sacks | 2pcs |
| Capacity of sacks | 0.25mp |
| Weight | 110kg |
| Recommended conveying air velocity in the duct | 20m/s |

TABLE 8-1

*. The noise level measurement was taken in accordance with PN-EN ISO 3746 Standard . The noise exposure level given above concerns an 8-hour work day.

**.. The measured values refer to emission levels, not necessarily to noise levels in the workplace. Although there is a relation between emission levels and exposure levels, it is not possible to determine with certainty if preventives are needed or are not needed. The factors affecting a current level of noise exposure during work are inter alia room characteristics and characteristics of other noise sources, e.g. number of machines and machining operations nearby. Also, the permissible exposure level value may vary depending on country. This information enables the machine's user to better identify hazards and a risk .

SECTION 9 HYDRAULIC & AIR INFORMATION

9.1 Hydraulic Schematic

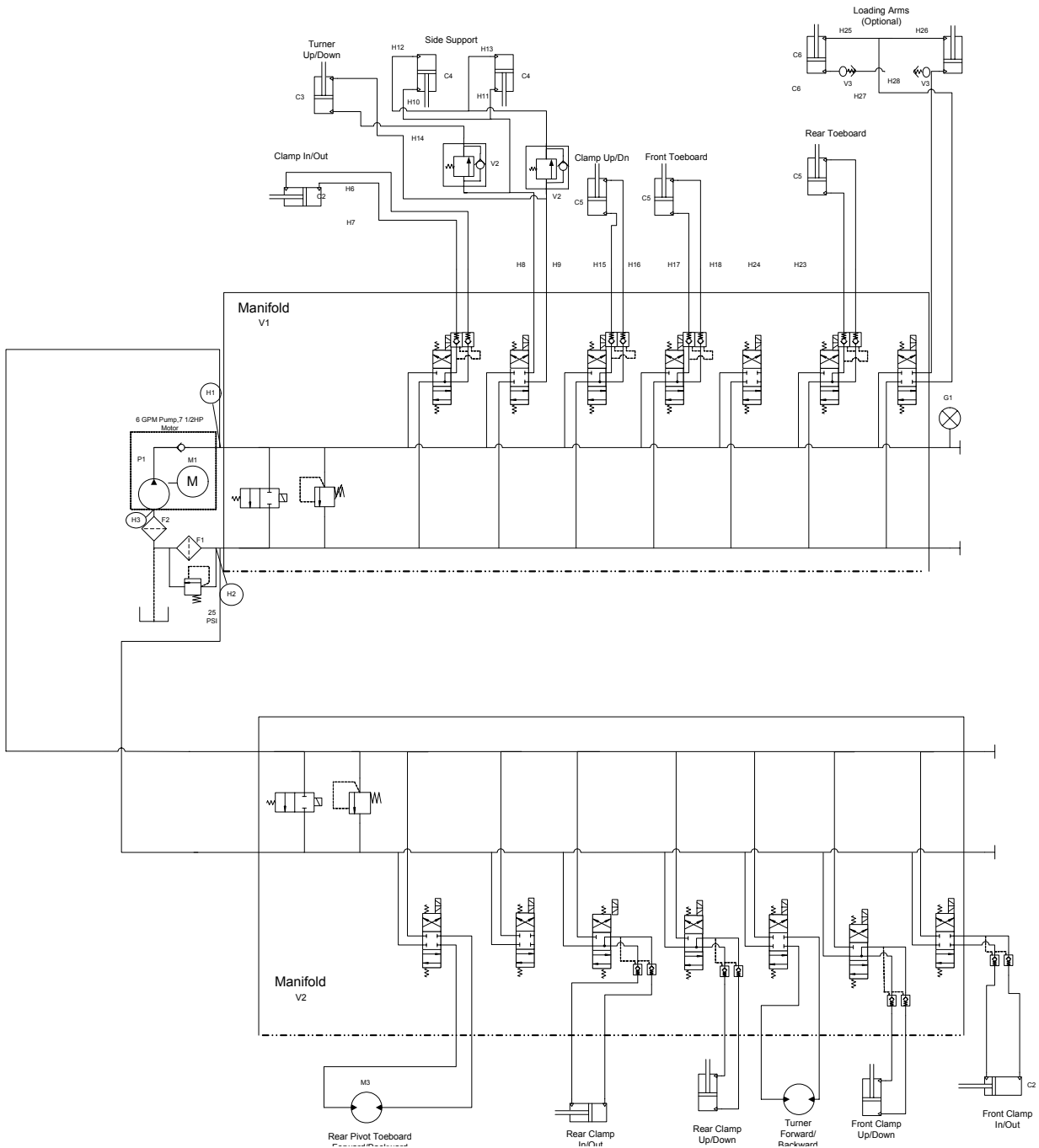

FIG. 9-1

9.2 Hydraulic Hoses

| ID | Color Code | Qty. | LENGTH "A" | Application | Wood-Mizer Part No. |
|-----|----------------------------|------|------------|--|---------------------|
| H1 | None | 1 | 1.1m | 3/8" Front Side Support From Tee Fitting, Base | 094593 |
| H2 | None | 1 | 0.95m | 3/8" Rear Side Support From Tee Fitting, Base | 094594 |
| H3 | None | 1 | 0.92m | 3/8" Front Side Support From Oil Flow Divider, Top | 094595 |
| H4 | None | 1 | 0.72m | 3/8" Rear Side Support From Oil Flow Divider, Top | 094596 |
| H5 | None | 1 | 0.65m | 3/8" Turner To Oil Flow Divider | 094597 |
| H6 | None | 1 | 0.62m | 3/8" Turner To Tee Fitting | 094598 |
| H7 | White/Orange | 2 | 4.5m | 1/4" Middle Pull-Down Clamp (In-Out) | 094752 |
| H8 | | 2 | 4.7m | 1/4" 1st Toe Board | 094753 |
| H9 | | 2 | 5.1m | 1/4" 2nd Pull-Down Clamp (Up/Down) | 094754 |
| H10 | Yellow | 1 | 7.4m | 1/4" 2-Plane Clamp, (Up/Down) Base | 094755 |
| H11 | Black (base)/ Purple (top) | 2 | 7.6m | 1/4" 2nd Toe Board | 094756 |
| H12 | Orange/White | 2 | 7.9m | 1/4" 3rd Pull-Down Clamp (In-Out) | 094757 |
| H13 | Red/Blue | 2 | 8.3m | 1/4" 3rd Pull-Down Clamp (Up-Down) | 094758 |
| H14 | | 2 | 6.3m | 1/2" Hydro-Motor | 094794 |
| H15 | | 2 | 6.5m | 3/8" Turner (Up-Down) | 094760 |
| H16 | Orange/White | 2 | 6.4m | 3/8" 2-Plane Clamp (In/Out) | 094761 |
| H17 | Blue/Red | 2 | 8m | 3/8" Log Infeed Deck | 094762 |
| H18 | White/Orange | 2 | 2.5m | 1/4" 1st Pull-Down Clamp (In/Out) | 095061 |
| H21 | Red/Blue | 2 | 3.2m | 1/4" 1st Pull-Down Clamp (Up/Down) | 095062 |
| H22 | | | 1.1m | 3/8" Low Pressure Valve to Filter | |
| | | | 1.1m | 3/8" Low Pressure Tank to Pump | |
| | | 2 | 8,2m | 1/4" Power Roller | 094758 |

TABLE 9-1

9.3 Hydraulic Components

| ID | Mfg. Part No. | Manufacturer | Wood-Mizer Part.# | Description |
|----|-----------------|-----------------------|-------------------|---|
| C1 | 017275 | J-D Hydraulic | 017275 | Hyd. Cylinder, 3" Bore X 7" Stroke |
| C2 | PMC-19410 | Prince Mfg. | 015050 | Hyd. Cylinder, 1 1/2" Bore X 10" Stroke |
| C3 | 034267 | J-D Hydraulic | 034267 | Hyd. Cylinder, 2" Bore x 10" Stroke |
| C4 | 035625 | J-D Hydraulic | 035625 | Hyd. Cylinder, 2" Bore X 6" Stroke |
| C5 | 014482 | J-D Hydraulic | 014482 | Hyd. Cylinder, 1 1/2" Bore x 6" Stroke |
| C6 | 042754 | J-D Hydraulic | 042754 | Hyd. Cylinder, 3" Bore X 8" Stroke |
| F1 | S28 | Hyd. Filter Supply | P20301 | Filter, Hydraulic Fluid Cartridge |
| F2 | S15-100 | FlowEzy | P20210 | Filter, Hydraulic Tank Suction |
| G1 | CF-1P-210A | Pressure Devices Inc. | P10052 | Gauge, 5000 PSI Hydraulic |
| M1 | LM24960 | Lincoln | 042776 | Motor, 7.5HP 213TC 50/60Hz 415/480V |
| M2 | MB29-02-08-AABP | Parker | 018741 | Motor, Hydraulic Log Turner Chain |
| M3 | MG06-13-13AAB | Parker | P21506 | Motor, Hydraulic Power Roller |
| P1 | 4F666 | Grainger | 042782 | Hydraulic Pump, 6GPM 50Hz |
| V1 | IFP-00405 24V/8 | Progressive Power | 042329 | Valve, 8-Section Hydraulic |
| V2 | 49005-1000 | Vonberg | 042724 | Sequence Valve, 1000 psi |
| V3 | 28001-503-6.0 | Vonberg | 042755 | Valve, Hydraulic 6GPM Velocity Fuse |

TABLE 9-2

B.1 Air Schematic

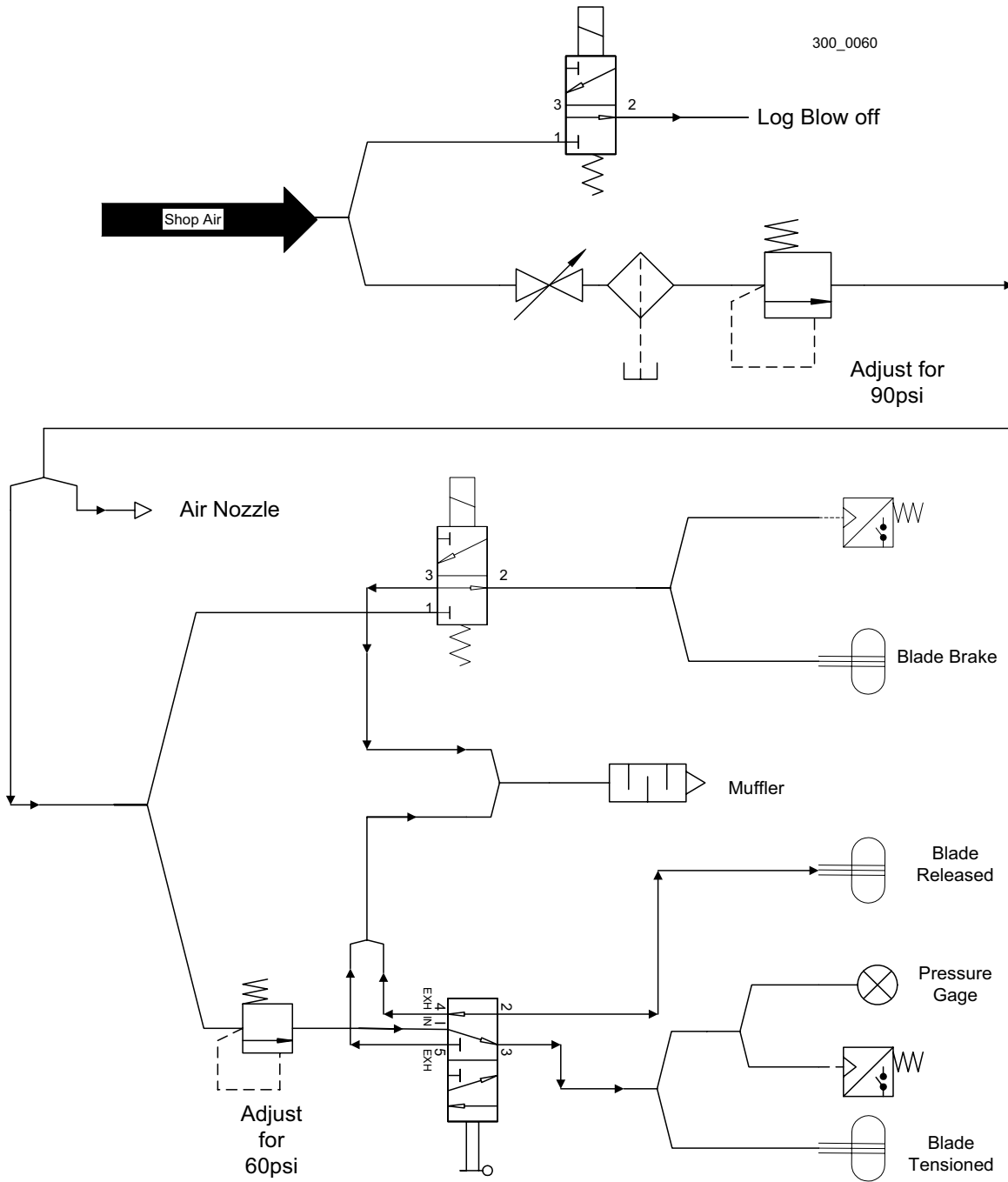

AIR SCHEMATIC

B.2 Head/Air Box Plumbing

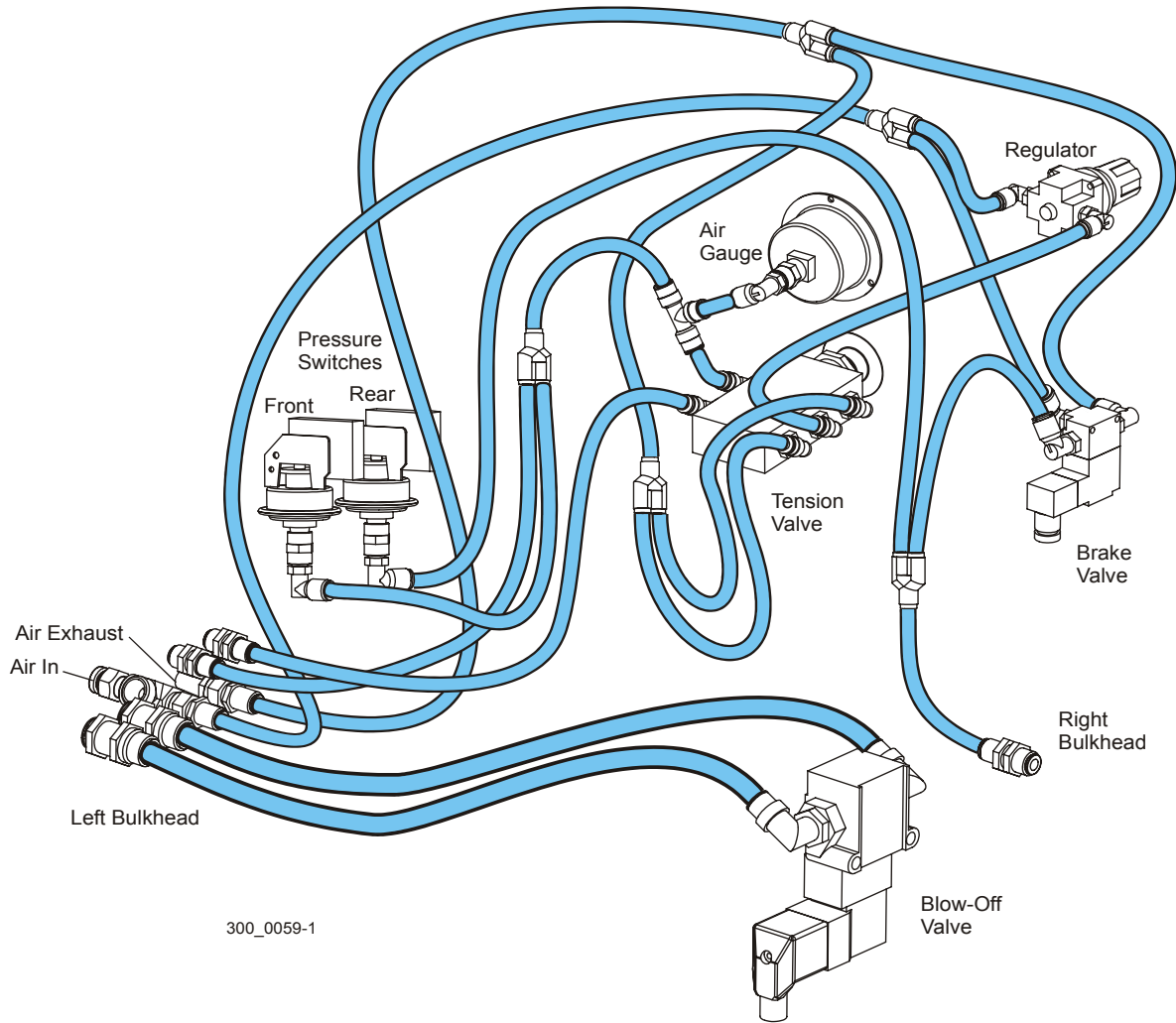

HEAD/AIR BOX PLUMBING

INDEX

A

alignment

- align side supports 7-6
- bed frame length 7-1
- bed frame width 7-2
- level bed rails 7-5
- level saw head 7-3
- optional block guides
 - blade guide 7-37
 - blade guide arm 7-35
 - blade guide overview 7-26
 - blade guide preparation 7-30
 - blade wheel vertical tilt 7-33
- standard block/roller guides
 - blade guide 7-16
 - blade guide arm 7-14
 - blade guide overview 7-7
 - blade guide preparation 7-11
 - blade wheel vertical tilt 7-12

B

belt

- tension 5-20, 5-22

C

chain

- feed tension 5-17
- maintenance 5-8

E

electrical installation

- blade motor cable 3-16
- head box cable 3-17
- lubemizer cable 3-20
- power feed cable 3-14
- transducer cable 3-19
- up/down brake cable 3-15
- up/down cable 3-14

H

hydraulic

- component ID 8-3
- hose ID 8-2
- schematic 8-1

M

maintenance

- blade guide 5-1
- blade guides 5-2
- blade wheel bearings/scrapers 5-14
- drive belt 5-20
- hydraulic system 5-13
- miscellaneous 5-8
- power feed 5-17
- proximity sensors 5-9
- sawdust removal 5-5
- track rails/scrapers 5-6
- turner chain 5-22
- up/down 5-14
- up/down system 5-15

O

operation

- control overview 4-1
- cruise control 4-11
- distribution box overview 4-3
- installing a blade 4-17
- joystick overview 4-4
- loading a log 4-20
- programming the control 4-12
- sawing the log 4-38
- setworks overview 4-26
 - board function 4-36
 - pattern mode 4-33
 - temporary reference mode 4-27
- starting the machine 4-16

S

safety

- instructions 1-2
- symbol definitions 1-1

service info

- customer/sawmill ID 2-2
- ordering parts 2-1

setup

- adjust transducer sensor 3-40
- air installation 3-27
- blade lube installation 3-4
- electrical installation 3-9
- final sawmill 3-28
- hydraulic installation 3-24
- initial control programming 3-40
- level bed rails 3-35
- level blade guide arm 3-36
- level saw head 3-31
- operator station installation 3-3
- sawmill installation 3-26
- side supports 3-39
- site preparation 3-1

specifications

- overall dimensions 7-41

T

troubleshooting

- blade guides 6-4
- error codes 6-1