

Accuset

Safety, Operation, Maintenance & Parts Manual

ASET for '97+ mills rev. A.00 - A.00



Safety is our #1 concern! Read and understand all safety information and instructions before operating, setting up or maintaining this machine.

Form #987

Table of Contents

Section-Page

| | | |
|------------------|--|-------------|
| SECTION 1 | INSTALLATION PROCEDURE | 1-1 |
| 1.1 | Pre-Installation Procedure | 1-1 |
| 1.2 | Sensor Installation (Rev. A.01+)..... | 1-3 |
| 1.3 | Sensor Installation (Rev. A.00) | 1-9 |
| 1.4 | Wiring Preparation | 1-15 |
| 1.5 | Wiring Installation for Super Sawmills..... | 1-19 |
| 1.6 | Wiring Installation for Standard Sawmills..... | 1-22 |
| 1.7 | Accuset Final Installation..... | 1-26 |
| SECTION 2 | SETUP & OPERATION | 2-1 |
| 2.1 | Control Setup..... | 2-1 |
| | <i>Contrast Adjustment.....</i> | <i>2-2</i> |
| | <i>Startup Configuration</i> | <i>2-2</i> |
| | <i>Other Settings.....</i> | <i>2-6</i> |
| 2.2 | Mode Selection..... | 2-11 |
| 2.3 | Using Auto-Down Mode | 2-13 |
| 2.4 | Using Auto-Up Mode | 2-15 |
| 2.5 | Using Pattern Mode..... | 2-16 |
| 2.6 | Using Reference Mode..... | 2-18 |
| SECTION 3 | ACCUSET TROUBLESHOOTING | 3-1 |
| 3.1 | Common Problems | 3-1 |
| 3.2 | Accuset Display Problems..... | 3-4 |
| | <i>Control Panel Replacement</i> | <i>3-5</i> |
| | <i>Resetting the Accuset</i> | <i>3-6</i> |
| 3.3 | Up/Down Control Lights..... | 3-7 |
| | <i>MOSFET Panel Test</i> | <i>3-10</i> |
| | <i>Replacing the MOSFET Panel.....</i> | <i>3-11</i> |
| 3.4 | Accuracy Problems..... | 3-12 |
| SECTION 4 | REPLACEMENT PARTS | 4-1 |
| 4.1 | Sensor Assembly | 4-1 |
| 4.2 | Control Assembly..... | 4-3 |
| 4.3 | Cover Assembly | 4-5 |
| | INDEX | I |

SECTION 1 INSTALLATION PROCEDURE

1.1 Pre-Installation Procedure

1. Remove the drive pulley/belt cover from the sawmill.
2. If applicable, disconnect the encoder cable from the existing Networks control and remove the encoder and mounting bracket from the sawmill.
3. Remove the scale pointer assembly from the mill. Set the mounting hardware aside.
4. Remove the existing blade height scale assembly from the mill. Remove the scales from the scale mounting bracket, then set the scales and mounting hardware aside.

NOTE: Sawmills manufactured after 11/00 have four threaded holes in the mast. If your sawmill has the threaded holes, skip to Sensor Installation ([See Section 1.2](#)). If your sawmill does not have the threaded holes, continue with this procedure.

5. Position the supplied template on the sawmill vertical mast tube 4 5/16" from the top of the tube.

1 Installation Procedure

Pre-Installation Procedure

See Figure 1-1.

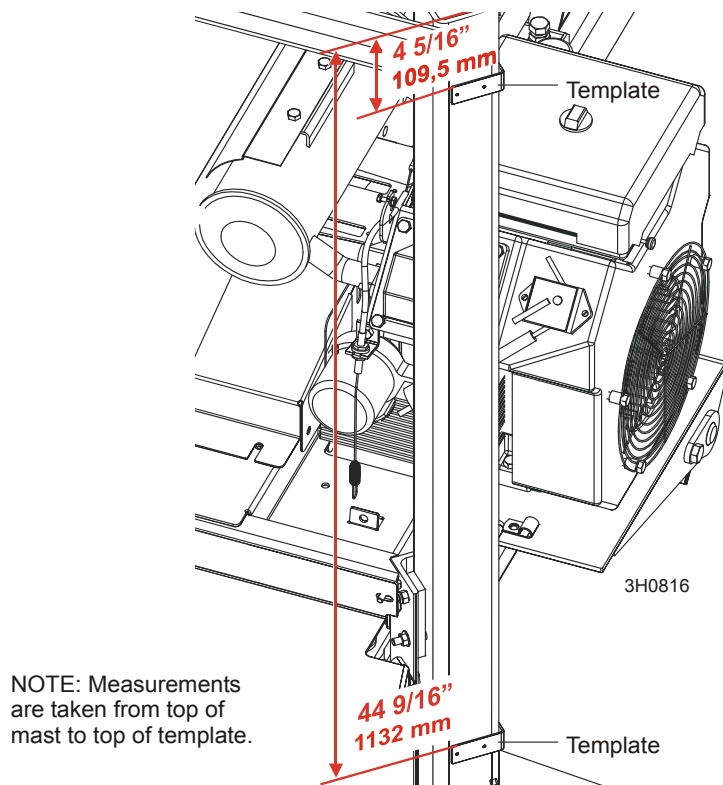

FIG. 1-1

6. Mark the locations indicated by the holes in the template on the mast tube.

NOTE: Accurate location is necessary for proper mechanical and sensor operation.

7. Relocate the template 44 9/16" from the top of the mast tube and mark the two hole locations.
8. Use the #3 (7/32") drill bit provided to drill holes through one wall of the mast tube at all four locations.
9. Thread all four holes with the 1/4-20 tap provided.

1.2 Sensor Installation (Rev. A.01+)

NOTE: The sensor mounting brackets were redesigned in April 2001. [See Section 1.3](#) if your mounting brackets do not look like the ones shown below.

1. Install the magnet to the bracket with the provided #8-32 x 7/8" hex head bolts, flat washers and nylon lock nuts. Slide the magnet assembly onto the sensor (the assembly will be secured later).

See Figure 1-2.

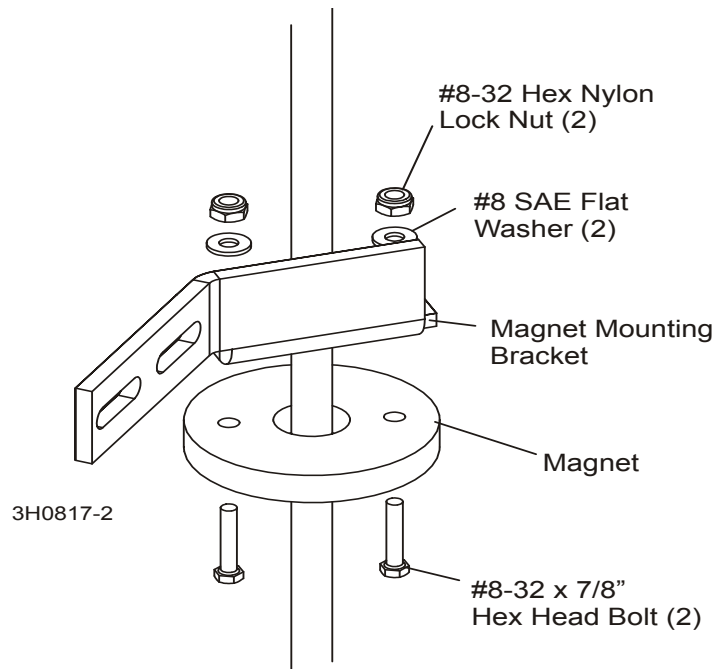

FIG. 1-2

1 Installation Procedure

Sensor Installation (Rev. A.01+)

2. Install the 3/8" ID grommet to the upper mount bracket and install to the top of the sensor.

See Figure 1-3.

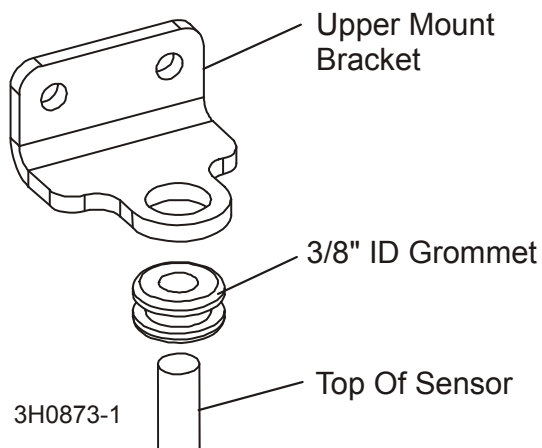

FIG. 1-3

3. Install two of the provided 1/4" lock washers and 1/4-20 x 5/8" hex head bolts to the bottom set of threaded holes in the mast. Thread the bolts about halfway into the holes. Slide the slotted lower mounting bracket of the sensor assembly around the two bolts, behind the lock washers. Slide the upper mounting bracket up or down as necessary so the bracket holes align with the holes in the mast. Secure with the remaining two lock washers and hex head bolts. Tighten all four mounting bolts.

See Figure 1-4.

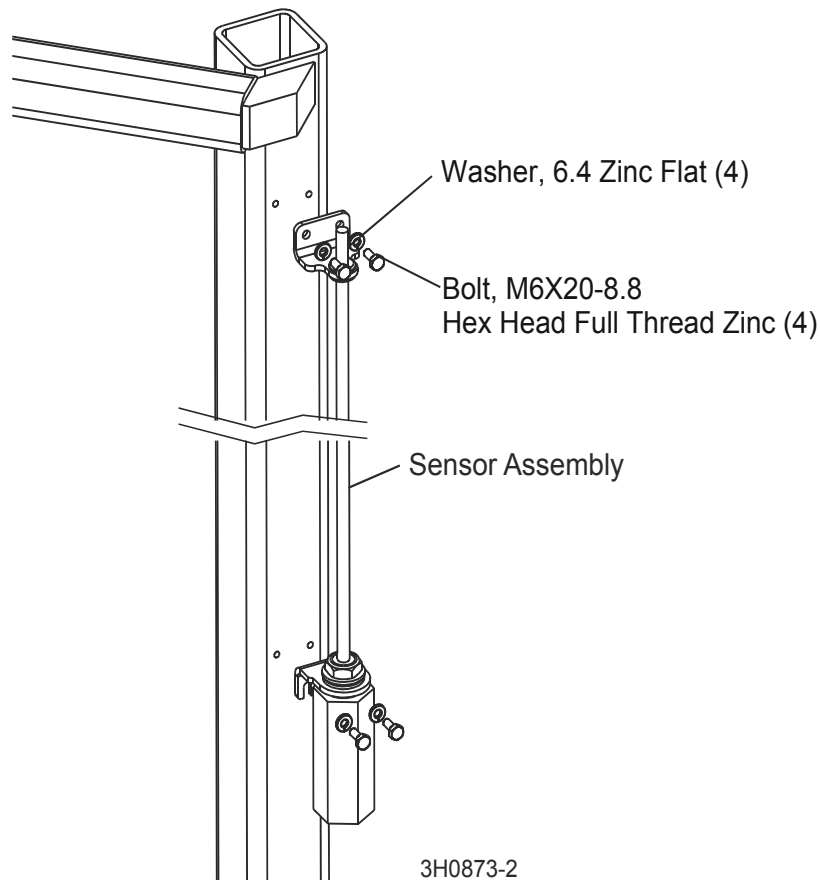

FIG. 1-4

1

Installation Procedure

Sensor Installation (Rev. A.01+)

4. Remove the blade height and quarter scales from the removed scale mount bracket. Use the existing hardware to secure the scales to the provided scale mount bracket. Assemble the new scale mount bracket to the sawmill mast, using existing hardware.
5. Install the sensor magnet mount block to the scale mount bracket using the four provided #10-24 x 1/2" hex head bolts and flat washers. Check the area between the bracket and block. If there is a gap, use the provided extra #10 washers as necessary to fill the gap. This will prevent bending of the scale bracket when the mounting bolts are tightened.
6. Position the magnet assembly so the holes in the magnet mounting bracket align with the holes in the magnet mount block.
7. Secure the magnet assembly to the mount block with the provided 1/4-20 x 3/4" hex head bolts and flat washers.

See Figure 1-5.

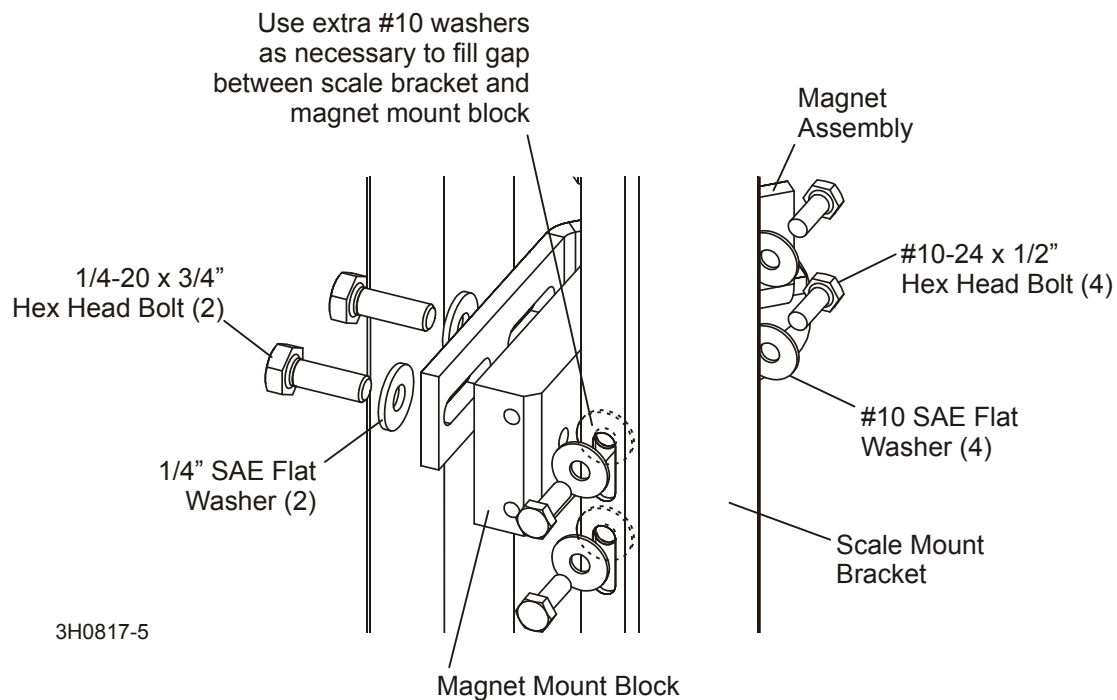

FIG. 1-5

8. Use the two provided #10-24 x 3/8" flat socket head screws and nylon lock jam nuts to secure the provided clear scale pointer to the new pointer mount plate. Then, use existing hardware to secure the pointer mount plate to the sawmill.

See Figure 1-6.

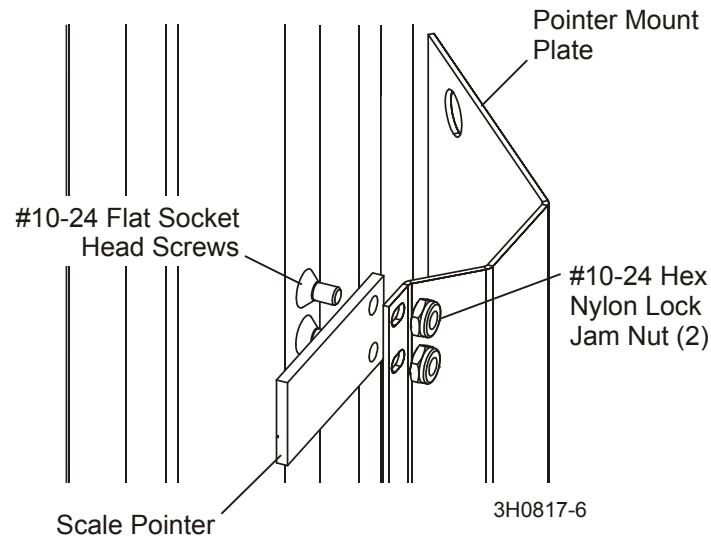

FIG. 1-6

9. Apply the appropriate decals supplied to the pointer mount plate.

1 **Installation Procedure**

Sensor Installation (Rev. A.01+)

1.3 Sensor Installation (Rev. A.00)

NOTE: The sensor mounting brackets were redesigned in April 2001. [See Section 1.2](#) if your mounting brackets do not look like the ones shown below.

1. Install the lower mount clamp (with large hole) flush with the threaded portion at the base of the sensor. Use two of the provided 1/4-20 x 3/4" flat socket head bolts to secure a mounting block to the clamp. The clamp and block should be oriented as shown to ensure proper assembly to the sawmill. The sensor should be oriented so the specification label faces away from sawmill bed. Use one of the provided 1/4-20 x 1" socket head bolts to secure the clamp to the sensor.

See Figure 1-7.

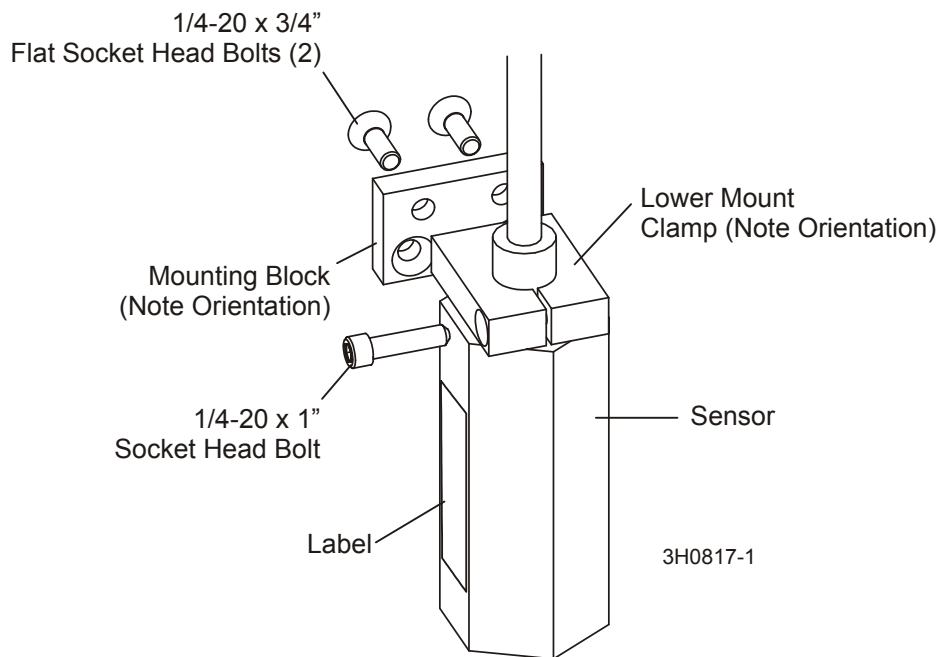

FIG. 1-7

1

Installation Procedure

Sensor Installation (Rev. A.00)

2. Install the magnet to the bracket with the provided #8-32 x 7/8" hex head bolts, flat washers and nylon lock nuts. Slide the magnet assembly onto the sensor (the assembly will be secured later).

See Figure 1-8.

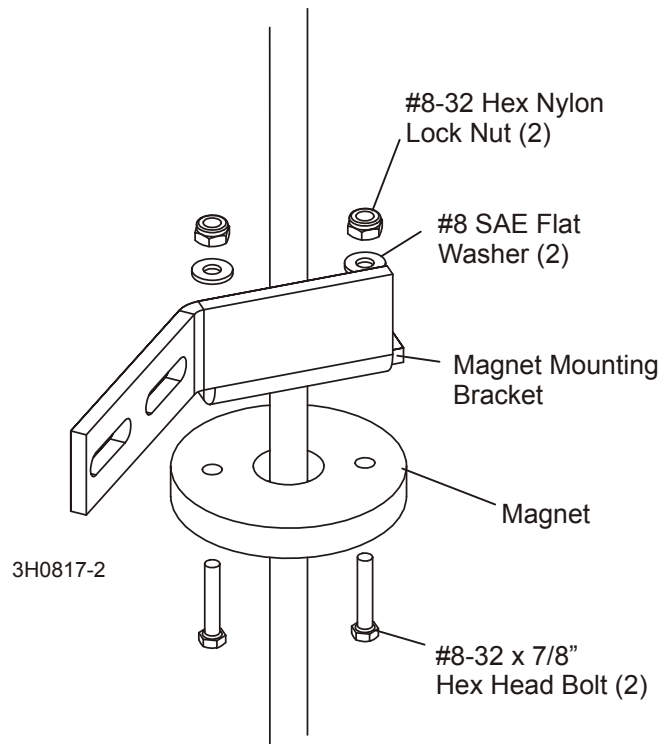

FIG. 1-8

3. Install the upper mount clamp (with small hole) at the top of the sensor. Use two of the provided 1/4-20 x 3/4" flat socket head bolts to secure a mounting block to the clamp. Note the orientation of the mount clamp and mounting block. The clamp and block should be oriented as shown to ensure proper assembly to the sawmill. Use one of the provided 1/4-20 x 1" socket head bolts to secure the clamp to the sensor.

See Figure 1-9.

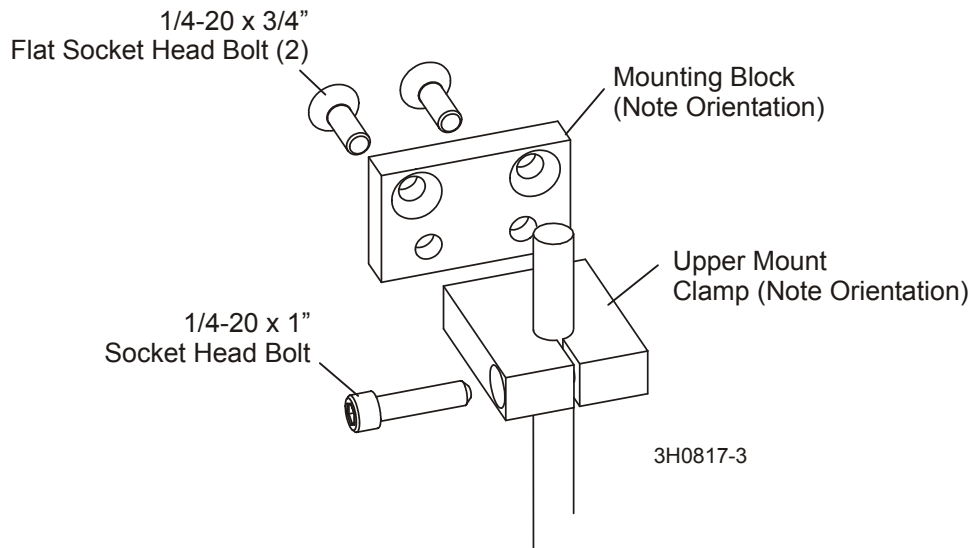

FIG. 1-9

1

Installation Procedure

Sensor Installation (Rev. A.00)

4. Use four of the provided 1/4-20 x 3/4" flat socket head bolts to install the sensor assembly to the threaded holes in the mast tube. Loosen the upper or lower clamp bolts to adjust the mounts as necessary. While the clamps are loose, lower the sensor to allow access to the lower mounting bolts. Reposition the sensor and retighten the clamp bolts after the assembly is bolted to the mast.

See Figure 1-10.

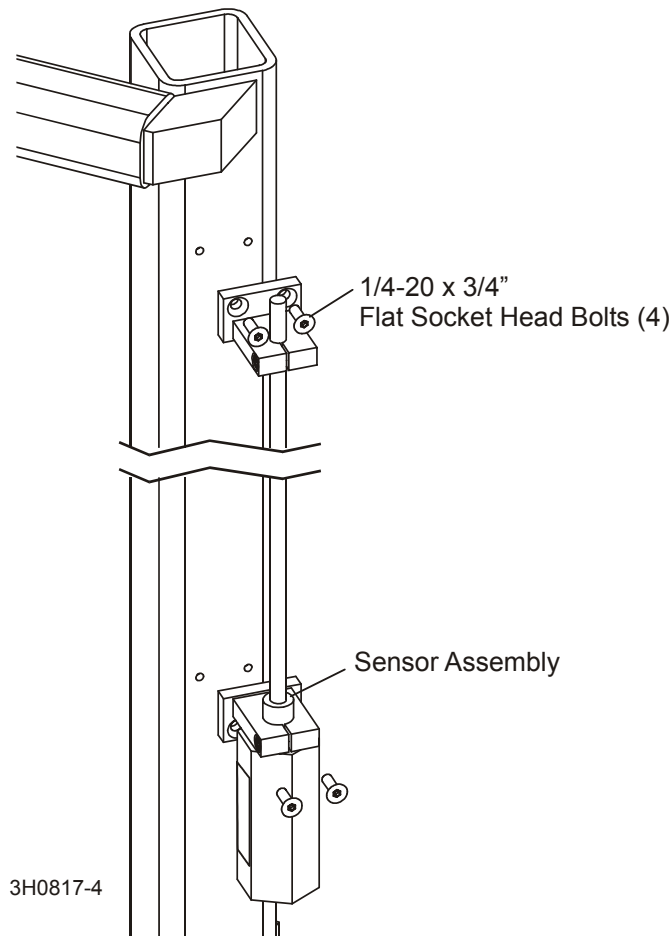

FIG. 1-10

5. Remove the blade height and quarter scales from the removed scale mount bracket. Use the existing hardware to secure the scales to the provided scale mount bracket. Assemble the new scale mount bracket to the sawmill mast, using existing hardware.
6. Install the sensor magnet mount block to the scale mount bracket using the four provided #10-24 x 1/2" hex head bolts and flat washers. Check the area between the bracket and block. If there is a gap, use the provided extra #10 washers as necessary to fill the gap. This will prevent bending of the scale bracket when the mounting bolts are tightened.
7. Position the magnet assembly so the holes in the magnet mounting bracket align with the holes in the magnet mount block.
8. Secure the magnet assembly to the mount block with the provided 1/4-20 x 3/4" hex head bolts and flat washers.

See Figure 1-11.

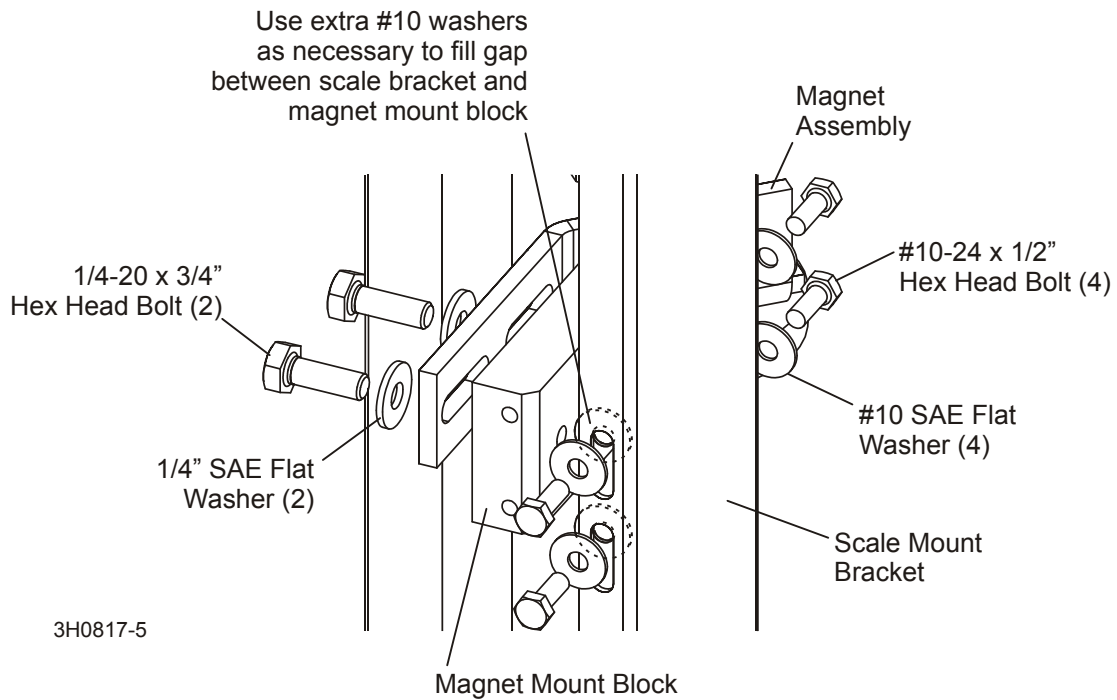

FIG. 1-11

1

Installation Procedure

Sensor Installation (Rev. A.00)

9. Use the two provided #10-24 x 3/8" flat socket head screws and nylon lock jam nuts to secure the provided clear scale pointer to the new pointer mount plate. Then, use existing hardware to secure the pointer mount plate to the sawmill.

See Figure 1-12.

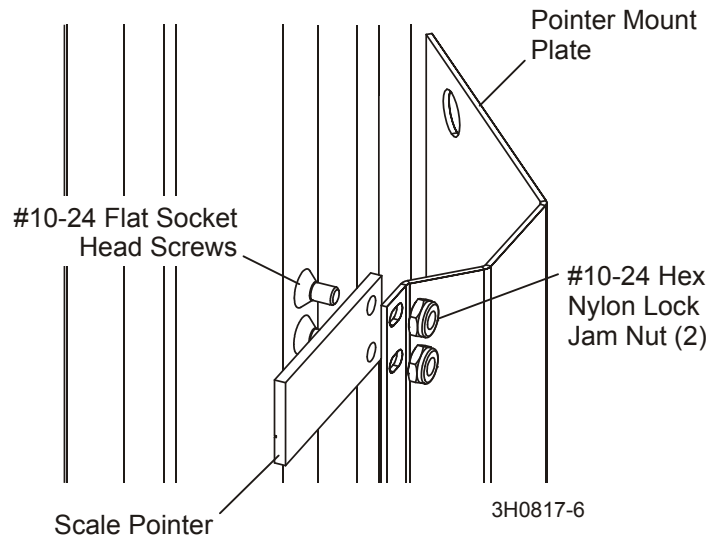

FIG. 1-12

10. Apply the appropriate decals supplied to the pointer mount plate.

1.4 Wiring Preparation

1. If your sawmill is equipped with a previous version Networks option, skip to Final Installation ([See Section 1.7](#)).

IMPORTANT! Make sure the mill is properly set up before performing Accuset installation and/or operation.



WARNING! Failure to put front outrigger down before moving cutting head from the rest position (rear of the mill) may result in serious injury.

2. Return the saw carriage to the front of the mill.
3. Raise the cutting head to the 22 inch mark on the blade height scale.
4. Turn the sawmill control box key to the OFF (#0) position and remove the key.
5. Unbolt and remove the top cover from the battery box and set aside. Remove the negative battery terminal from the battery post to disconnect power from the mill. Wrap a cloth or temporary insulating material around the terminal to ensure it does not contact the post during Accuset installation.



WARNING! Before performing any service to the sawmill control box panel, turn the key to the OFF position, disconnect the negative battery lead, and remove all rings, watches, etc.... Failure to do so may cause serious injury and machine damage.

1 Installation Procedure

Wiring Preparation

See Figure 1-13.

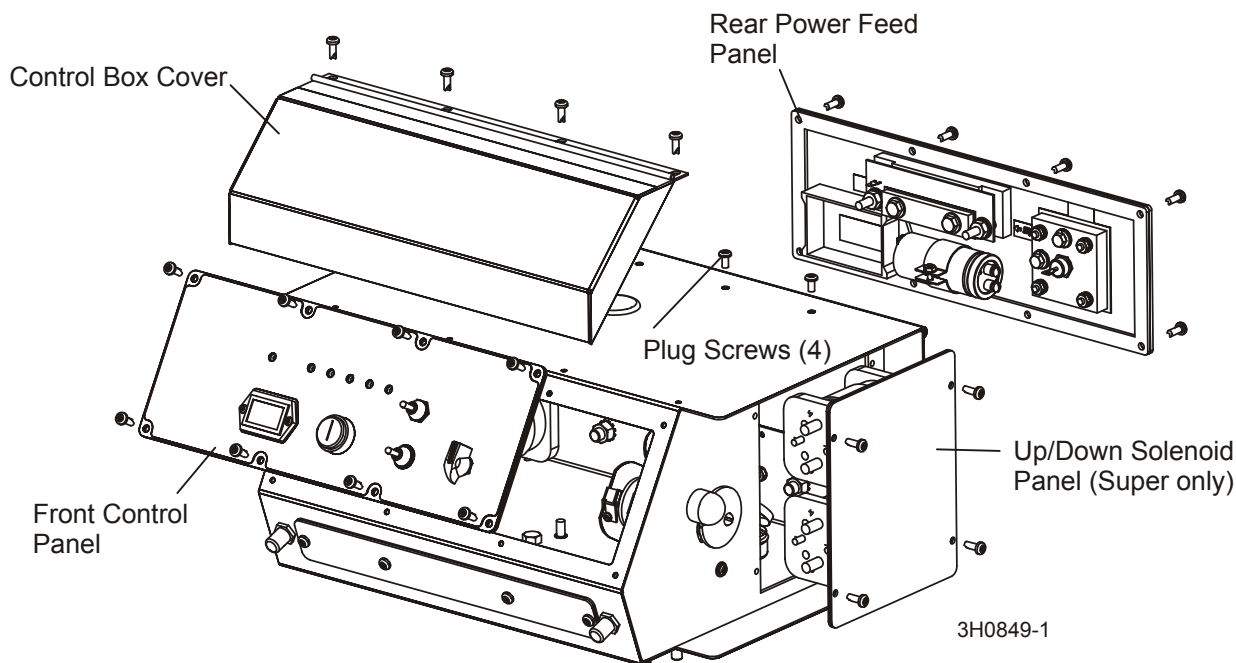

FIG. 1-13

6. Unbolt and remove the rear power feed panel from the sawmill control box. Leave all wires connected.
7. Unbolt and remove the front panel from the control box. Leave all wires connected.
8. Unbolt and remove the top hinged cover from the control box. Set aside.
9. Remove the four plug screws and nuts from the top of the control box.
10. **Super models only:** Unbolt and remove the up/down solenoid panel from the control box. Leave all wires connected.
11. Remove the plug from the 1" diameter hole in the top of the control box.
12. Install the provided L-shaped bar clamp to the top of the control box. Position the bracket as shown. Use the four provided #10 flat washers and 10-24 x 1/2" hex head bolts to

loosely secure in place from the bottom (do not tighten).

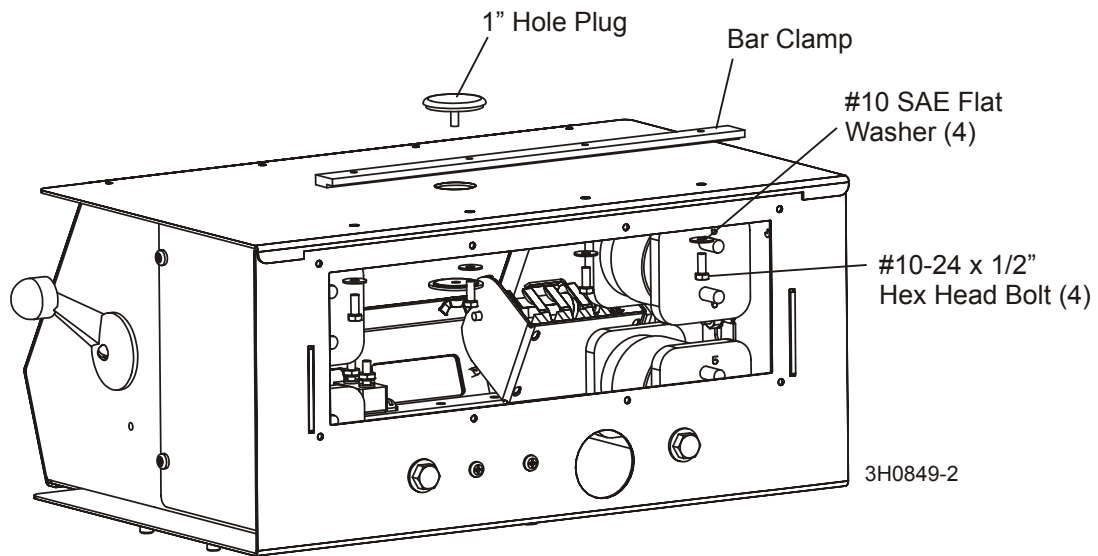

FIG. 1-13

1

Installation Procedure

Wiring Preparation

See Figure 1-14.

13. Remove the anti-rotation screw from the right side of the control box.
14. Unbolt and remove the up/down drum switch handle from the right side of the control box. Loosen the two drum switch mounting screws securing the up/down drum switch to the control box.
15. Proceed to [Section 1.5 Wiring Installation for Super Sawmills](#) or [Section 1.6 Wiring Installation for Standard Sawmills](#).

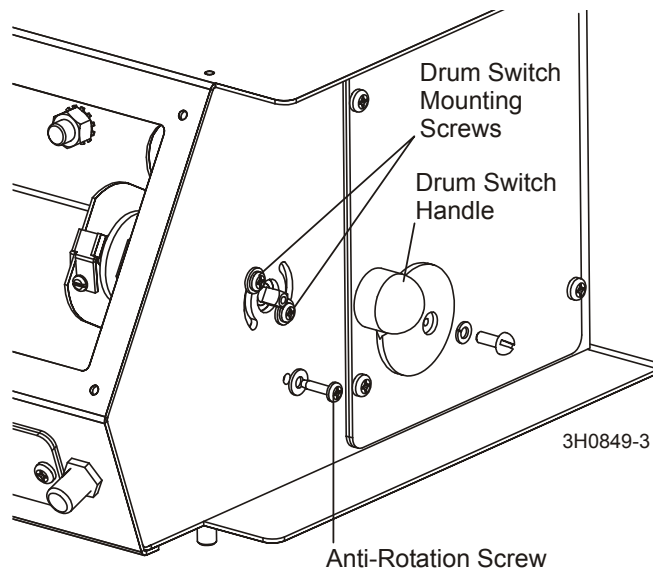

FIG. 1-14

1.5 Wiring Installation for Super Sawmills

1. If your sawmill is equipped with a previous version Networks option, skip to Final Assembly ([See Section 1.7](#)).



IMPORTANT! If you have a Super model sawmill, follow the wiring installation instructions located in this section. If you have a standard model sawmill, follow the wiring installation instructions found in [Section 1.6 Wiring Installation for Standard Sawmills](#).



WARNING! Before performing any service to the sawmill control box panel, turn the key to the OFF position, disconnect the negative battery lead, and remove all rings, watches, etc.... Failure to do so may cause serious injury and machine damage.

See Figure 1-15.

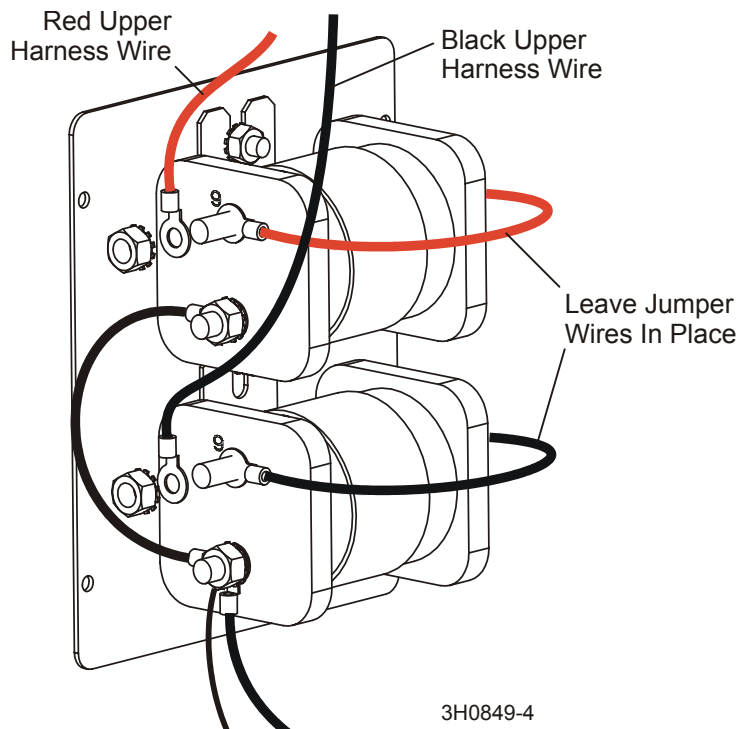

FIG. 1-15

1. Remove the nut and the existing red upper harness wire from the top post of the top solenoid. Remove the nut and the existing black upper harness wire from the top post of the

1

Installation Procedure

Wiring Installation for Super Sawmills

bottom solenoid. Be sure to leave the existing jumper wires in place. Reinstall the nuts.

NOTE: If your up/down solenoid orientation is different than shown, the solenoid panel may be installed upside down. Rotate the panel 180°.

2. Connect the black wire removed from bottom solenoid to the provided black wire labeled MOTOR. Secure with the provided 1/4-20 x 3/8" screw, flat washer and self-locking nut.

Connect the red wire removed from the top solenoid to the provided red wire labeled MOTOR. Secure with the provided 1/4-20 x 3/8" screw, washer and self-locking nut.

Slide one end of the provided 6" piece of rubber tubing over each connection. Bend the rubber tubing over to prevent connections from contacting each other and use a 6" wire tie to secure the rubber tubing in place. Use a diagonal wire cutter to remove the excess ends of the wire tie.

See Figure 1-16.

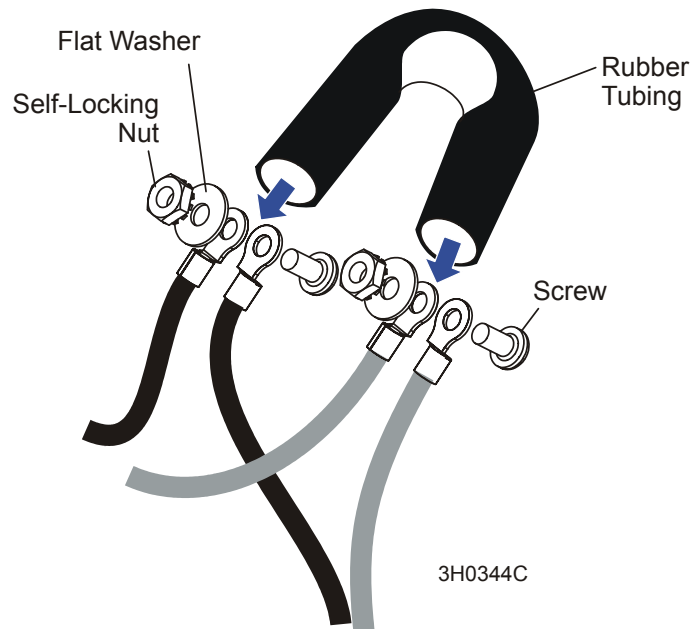

FIG. 1-16

See Figure 1-17. There are two red 12VDC wires provided. Only one of these wires will be used, depending upon your mill model. Both wires have a 1/4" ring terminal connected to one end. For Super model sawmills, use the wire with the 5/16" ring terminal on the other end of the wire. For Standard model sawmills, use the wire with the #10 fork terminal on the other end of the wire.

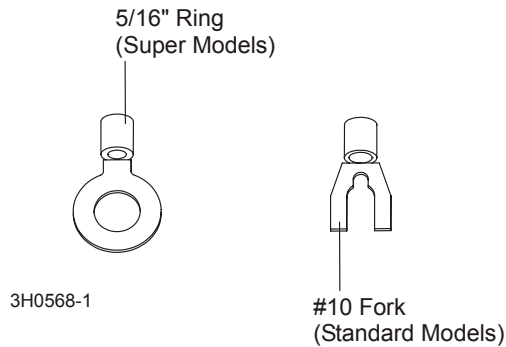

FIG. 1-17

3. Install the red 12VDC wire to terminal 3 of Solenoid 4 or 5. For best results, install to solenoid terminal with only one pre-existing connection. Be sure to leave the pre-existing connection in place. To install, remove the 5/16" hex nut and lock washer from solenoid terminal, install ring terminal to solenoid terminal, and replace lock washer and hex nut. Tighten to secure. Reinstall the side panel to the sawmill control box.

See Figure 1-18.

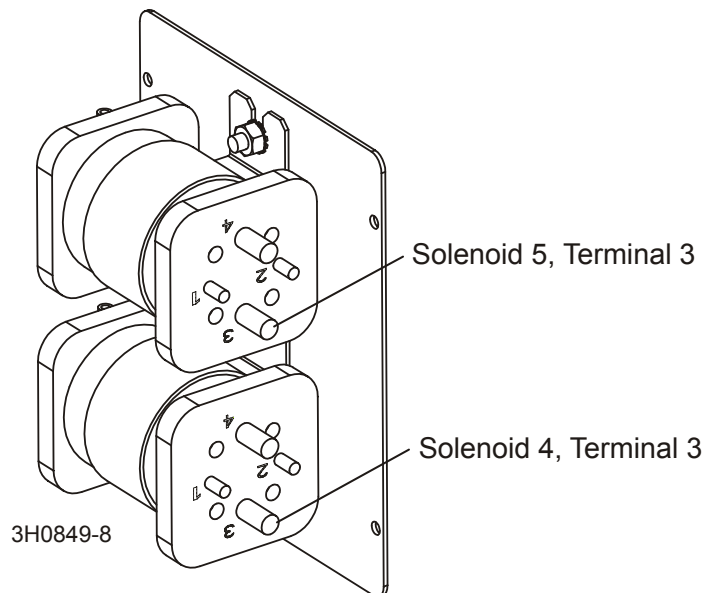

FIG. 1-18

1

Installation Procedure

Wiring Installation for Standard Sawmills

1.6 Wiring Installation for Standard Sawmills

1. If your sawmill is equipped with a previous version Networks option, skip to Final Assembly ([See Section 1.7](#)).



IMPORTANT! If you have a standard model sawmill, follow the wiring installation instructions found in this section. If you have a Super model sawmill, follow the wiring installation instructions found in [Section 1.5 Wiring Installation for Super Sawmills](#).



WARNING! Before performing any service to the sawmill control box panel, turn the key to the OFF position, disconnect the negative battery lead, and remove all rings, watches, etc.... Failure to do so may cause serious injury and machine damage.

2. At the back of the up/down switch, locate the terminal with two orange wires connected (TRM1 or TRM5). Leave the orange jumper wire connected and disconnect the orange upper harness wire.

See Figure 1-19.

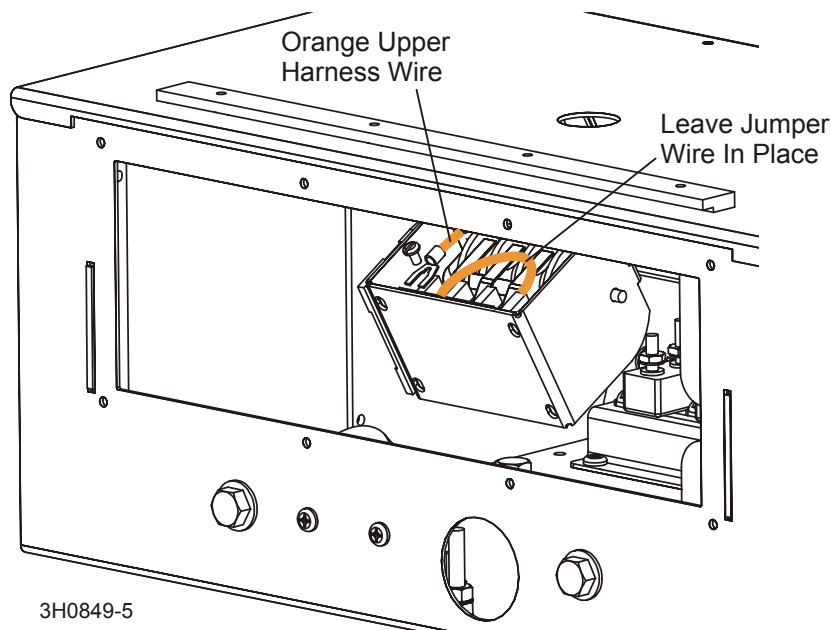

FIG. 1-19

3. On the front of the up/down drum switch, disconnect the existing black upper harness wire from TRM4. Leave the black jumper wire connected to TRM4.

See Figure 1-20.

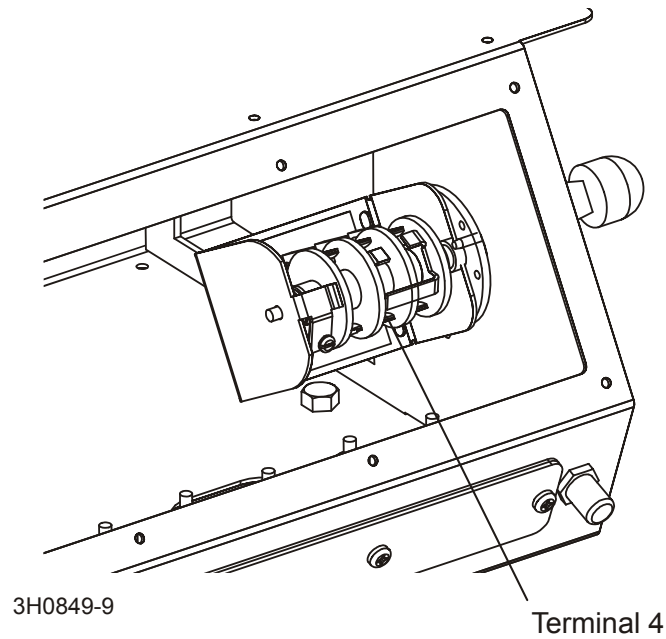

FIG. 1-20

1

Installation Procedure

Wiring Installation for Standard Sawmills

4. Connect the end of the orange wire removed from TRM1 or TRM5 to the provided red wire labeled MOTOR. Use the provided #10-24 x 3/8" screw, flat washer and self-locking nut to secure together.

Connect the end of the black wire removed from TRM4 to the provided black wire labeled MOTOR. Use the provided #10-24 x 3/8" screw, flat washer and self-locking nut to secure together.

Slide one end of the provided 6" piece of rubber tubing over each connection. Bend the rubber tubing over to prevent connections from contacting each other and use a 6" wire tie to secure the rubber tubing in place. Use a diagonal wire cutter to remove the excess ends of the wire tie.

See Figure 1-21.

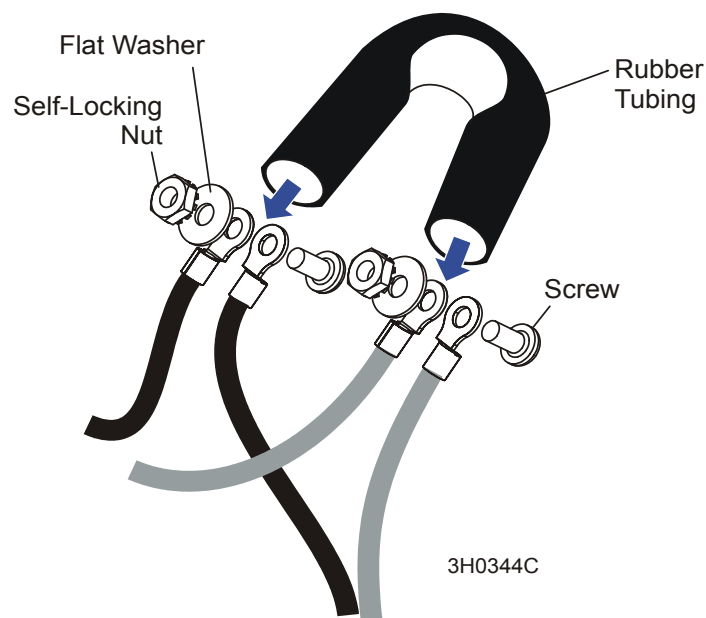

FIG. 1-21

See Figure 1-22. There are two red 12VDC wires provided. Only one of these wires will be used, depending upon your mill model. Both wires have a 1/4" ring terminal connected to one end. For standard model sawmills, use the wire with the #10 fork terminal on the other end of the wire.

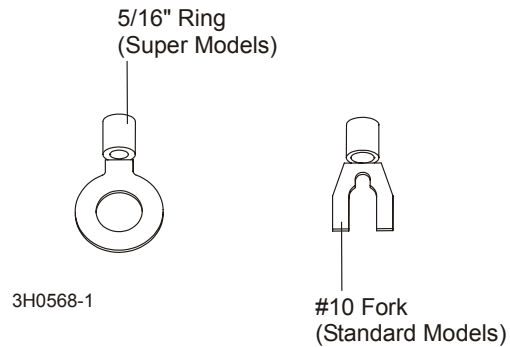

FIG. 1-22

5. Loosen the screw on terminal 2 of the up/down drum switch. Leaving any pre-existing connections in place, install the #10 fork to TRM 2 of the up/down drum switch. Retighten the screw to secure in place.

See Figure 1-23.

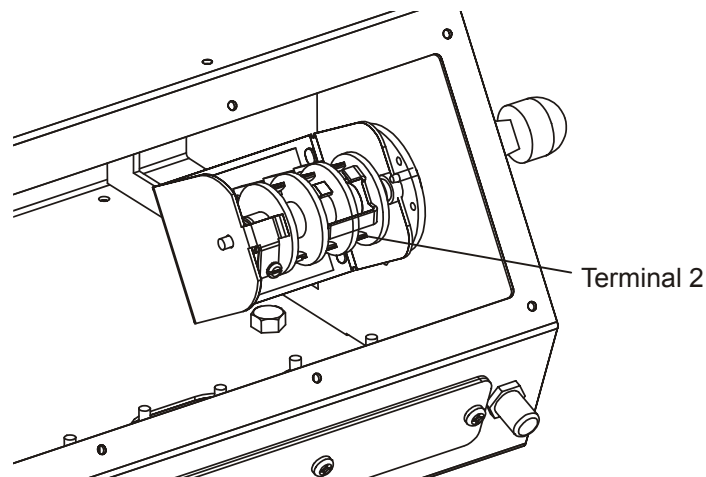

FIG. 1-23

1 Installation Procedure

Accuset Final Installation

1.7 Accuset Final Installation

See Figure 1-24.

1. Remove the existing 1/4-20 self-locking nut and flat washer which secure the existing wires on the back ground stud at the rear of the control box. Install the provided black wire labeled GND to the ground stud and replace the washer and self-locking nut. Tighten the nut securely.

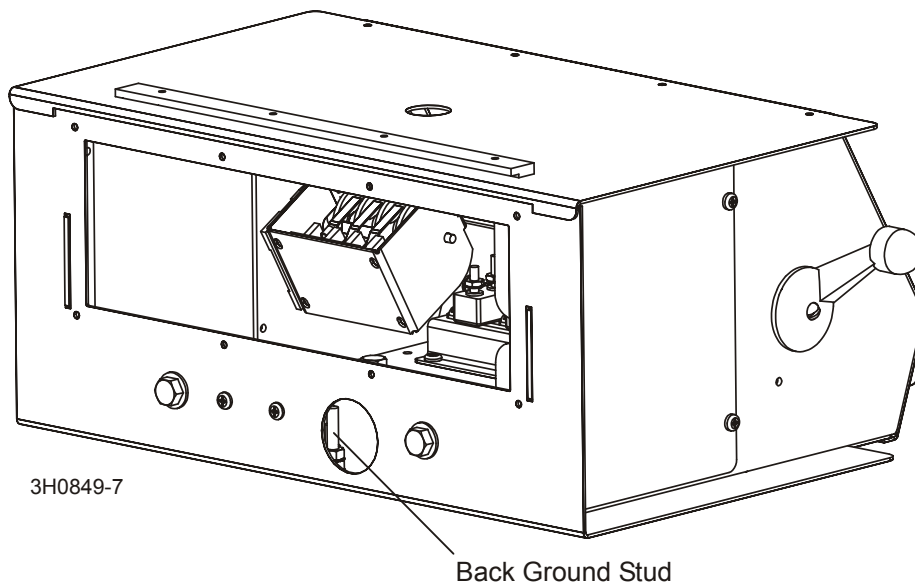

FIG. 1-24

2. Route the free ends of the black and red MOTOR wires, black GND wire and the red 12VDC wire through the hole in the top of the control box.
3. Temporarily place the Accuset control upright on top of the sawmill control box. Leave all pre-installed Accuset wires connected.
4. Route the black Accuset wire labeled DRUM UP and the red Accuset wire labeled DRUM DN through the hole in the top of the sawmill control box.

5. Connect the black Accuset DRUM UP wire to terminal 1 (TRM1) on the back of the up/down drum switch. Be sure to maintain any existing connections.

See Figure 1-25.

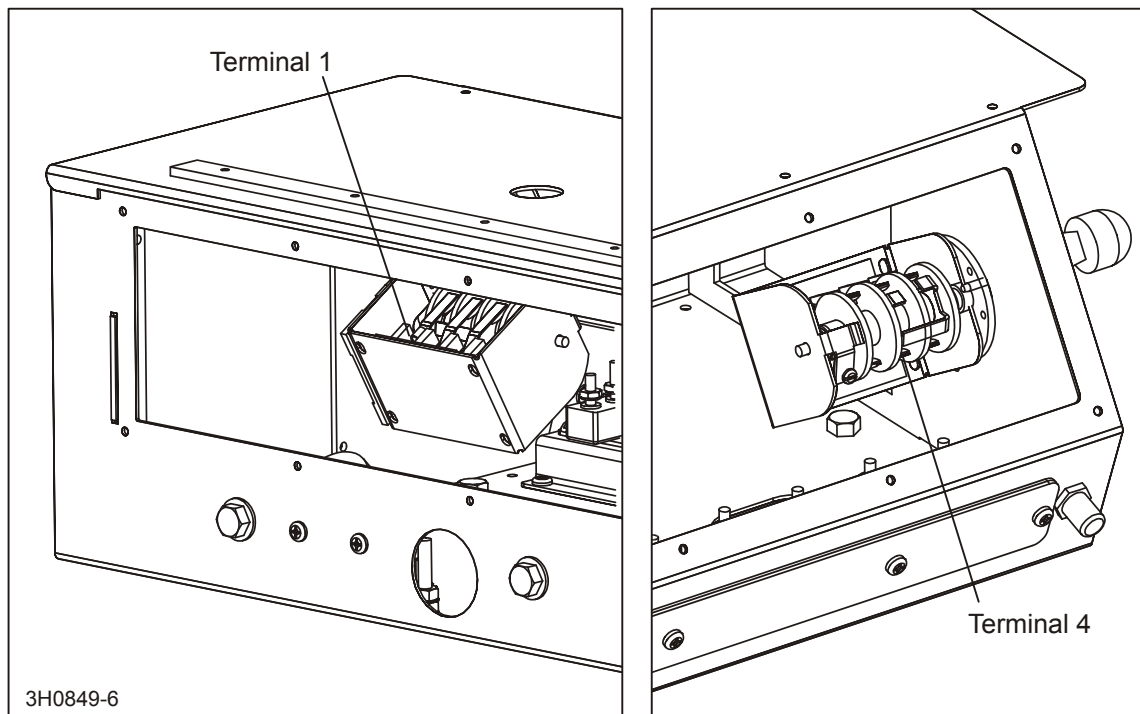

FIG. 1-25

6. Connect the red Accuset DRUM DN wire to TRM4 on the front of the up/down drum switch. Be sure to maintain any existing connections.
7. **Rev. C.00+ Only:** Connect the red Accuset Power Filter wire to the ACC terminal of the key switch.

1 Installation Procedure

Accuset Final Installation

- Connect the MOTOR, GND and 12VDC wires from the sawmill control box to the Accuset circuit board as shown below.

| Wire | Connection (Super Model Sawmills) | Connection (Standard Model Sawmills) | Connection Type |
|-----------------------------|-----------------------------------|--------------------------------------|--|
| Red DRUM DN | Up/Dn Drum Switch TRM 4 | Up/Dn Drum Switch TRM 4 | Fork Terminal |
| Black DRUM UP | Up/Dn Drum Switch TRM 1 | Up/Dn Drum Switch TRM 1 | Fork Terminal |
| Red Pwr Filter ¹ | Key Switch ACC | Key Switch ACC | Ring Terminal |
| Red MOTOR | MOTR Accuset Terminal | MOTL Accuset Terminal | Threaded Stud (Tighten lock nut to 85 in-lbs.) |
| Black MOTOR | MOTL Accuset Terminal | MOTR Accuset Terminal | Threaded Stud (Tighten lock nut to 85 in-lbs.) |
| Black GND | GND | GND | Threaded Stud (Tighten lock nut to 85 in-lbs.) |
| Red 12VDC | 12VDC | 12VDC | Threaded Stud (Tighten lock nut to 85 in-lbs.) |

¹ Power Filter added Accuset Rev. C.00

- Install the provided 8" conduit to the wires connecting the Accuset control to the sawmill control. Position the conduit about 3" - 4" inches from the wire terminals connected to the Accuset control. Secure each end of the conduit with two of the provided 6" tie wraps.

See Figure 1-26.

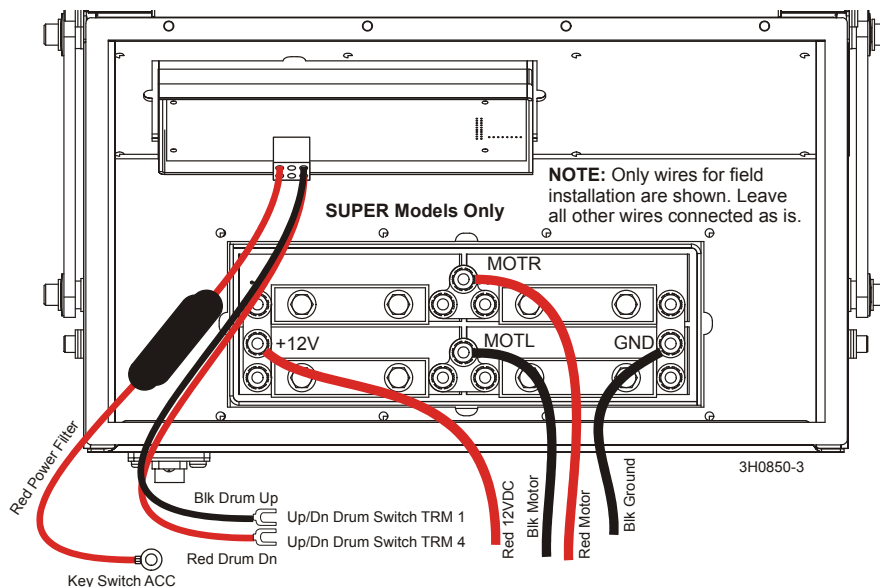

FIG. 1-26 SUPER MODELS ONLY (ACCUSET REV. C.00+)

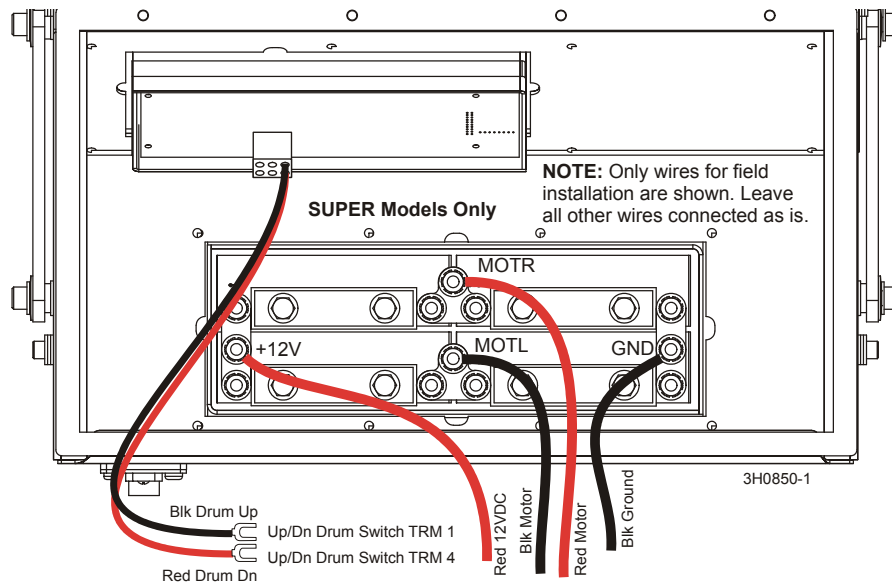

FIG. 1-26 SUPER MODELS ONLY (ACCUSET REV. A.00 - B.01)

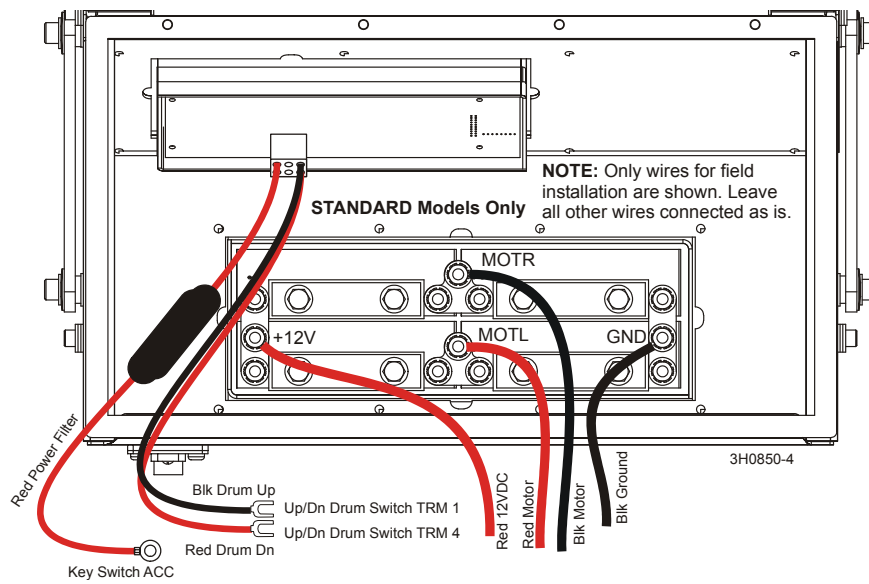

FIG. 1-26 STANDARD MODELS ONLY (ACCUSET REV. C.00+)

1 Installation Procedure

Accuset Final Installation

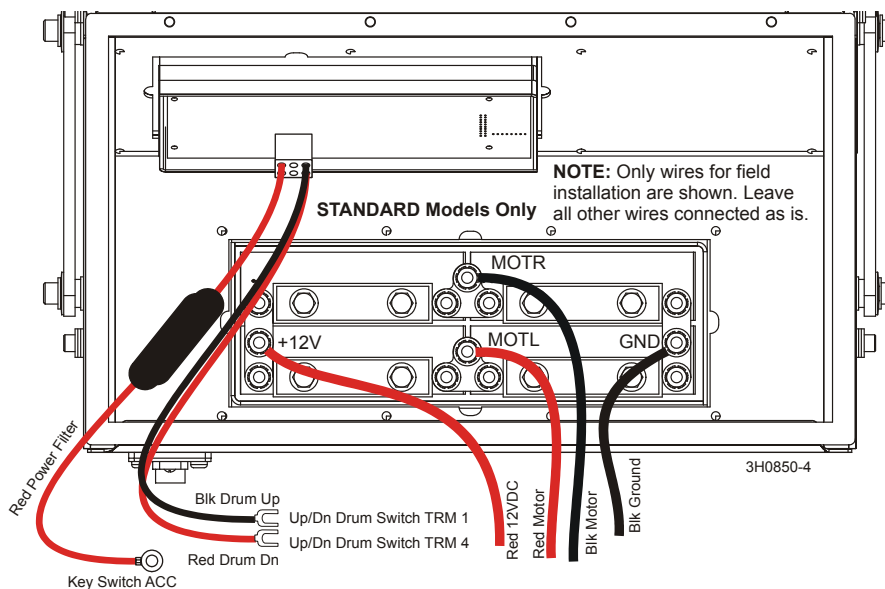

FIG. 1-26 STANDARD MODELS ONLY (ACCUSET REV. A.00 - B.01)

10. Reinstall the rear power feed panel and the front control panel to the sawmill control box.
11. Tighten the washers and screws securing the drum switch to the control box. Reinstall the drum switch handle. Reinstall the anti-rotation screw.

12. Install the Accuset control to the top of the sawmill control box.

Insert the Accuset control panel under the L-shaped bar clamp and slide forward into place. The four holes in the front of the Accuset control panel should align with the four holes in the top of the sawmill control box. Tighten the bar clamp mounting screws to secure the back of the Accuset control panel to the sawmill control box. Use the four existing #10-24 x 3/8" self-tapping screws (removed when original cover was removed) to secure the front of the Accuset control panel to the sawmill control box.

See Figure 1-27.

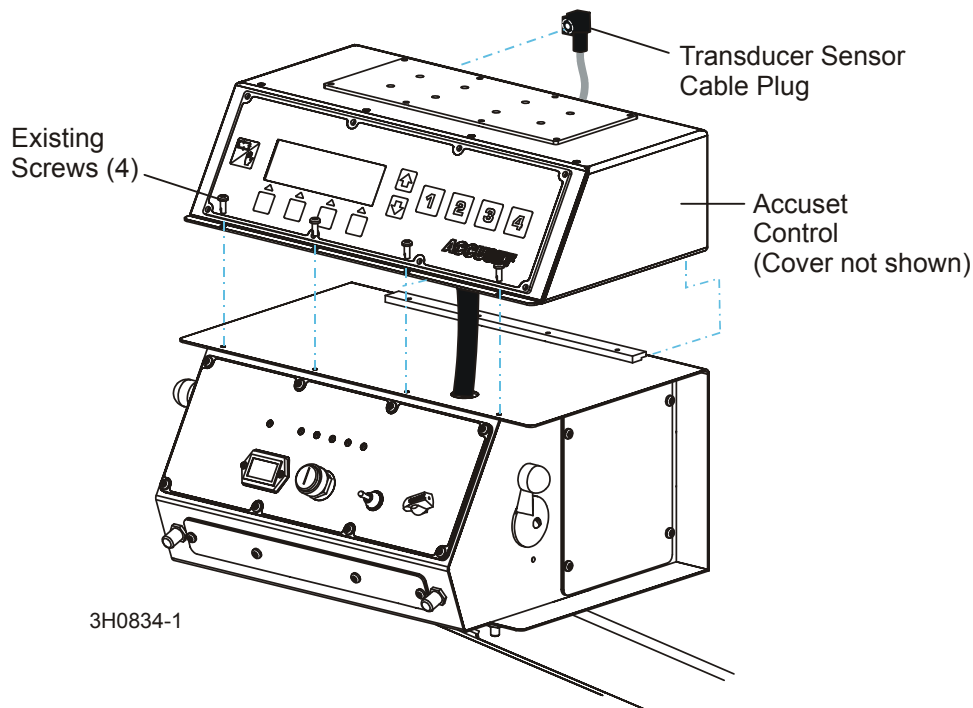

FIG. 1-27

13. Plug the cable from the transducer sensor into the connector in the back of the Accuset control box. Route the cable along the back side of the control pedestal and secure with the three 10" tie wraps provided.
14. Reconnect the negative battery lead and replace the battery box cover.

SECTION 2 SETUP & OPERATION

2.1 Control Setup

See **Figure 2-1**. Turn the key switch to the accessory (#3) position (use key switch position #1 on AC electric LT60HD/70HD sawmills). The Accuset control starts in Manual Mode by default. See the figure below for identification of the control buttons and display.

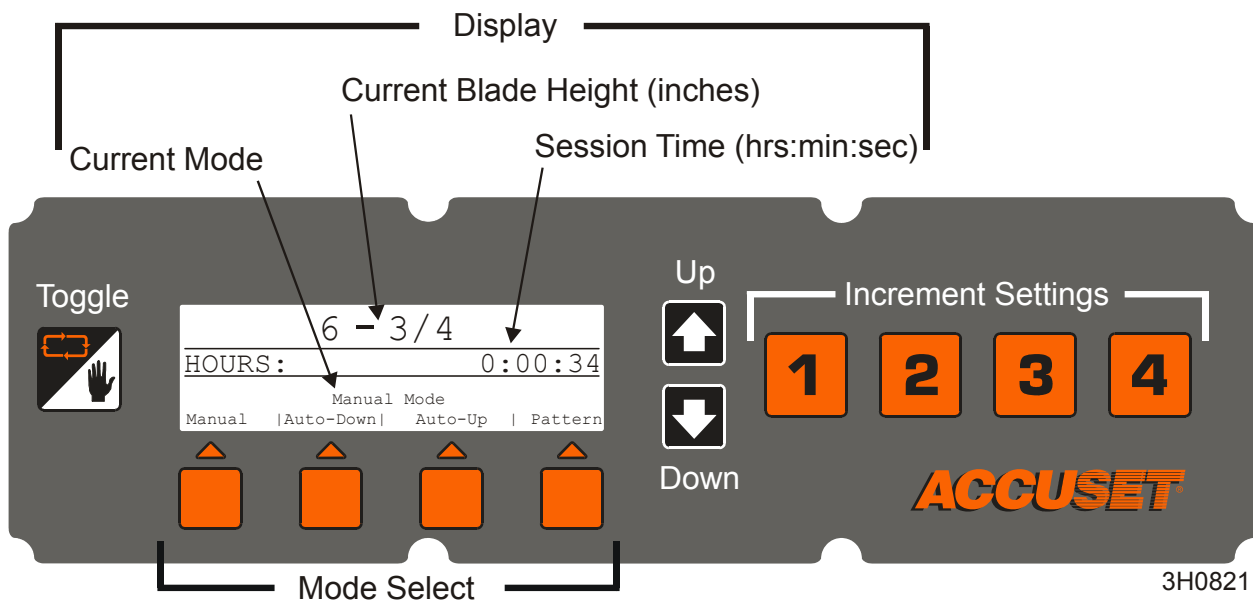

FIG. 2-1

About using the Up/Down Adjustment Buttons: To make adjustments to a setting, push the Up or Down arrow buttons to scroll to the desired setting. To scroll fast in the up direction, push and hold the Up button first. While pushing the Up button, push the Down button to increase scrolling speed. Quit pushing the Down button to slow scrolling. Quit pushing both buttons to stop scrolling. To scroll fast in the down direction, push and hold the Down button first, then push the Up button.

In Manual Mode, the up and down arrow buttons have special functions. You can enter configuration menus by pushing the Up button. Pushing the Down button displays the software revision of the Accuset control. Turning the key switch off (#0) and pressing both the Up and Down arrow buttons simultaneously resets the control to factory settings.

About the Toggle button: Use the Toggle button to exit configuration menus and return to the main menu.

2.1.1 Contrast Adjustment

When the Accuset is first powered on, the Adjust LCD Contrast screen is displayed for a few seconds. Push and hold the Up or Down button to adjust the display contrast as desired for your lighting conditions. To save the new contrast setting, push the Up arrow button and push Save Settings, then Save Now.

2.1.2 Startup Configuration

Accuset controls on new sawmills are configured at the factory. If you have installed or replaced the control, be sure to configure the control before operating the Accuset. Follow the procedures below *in the order they are listed*.

See Figure 2-2. To enter Configuration Menu 1, push the Up button while in Manual Mode.

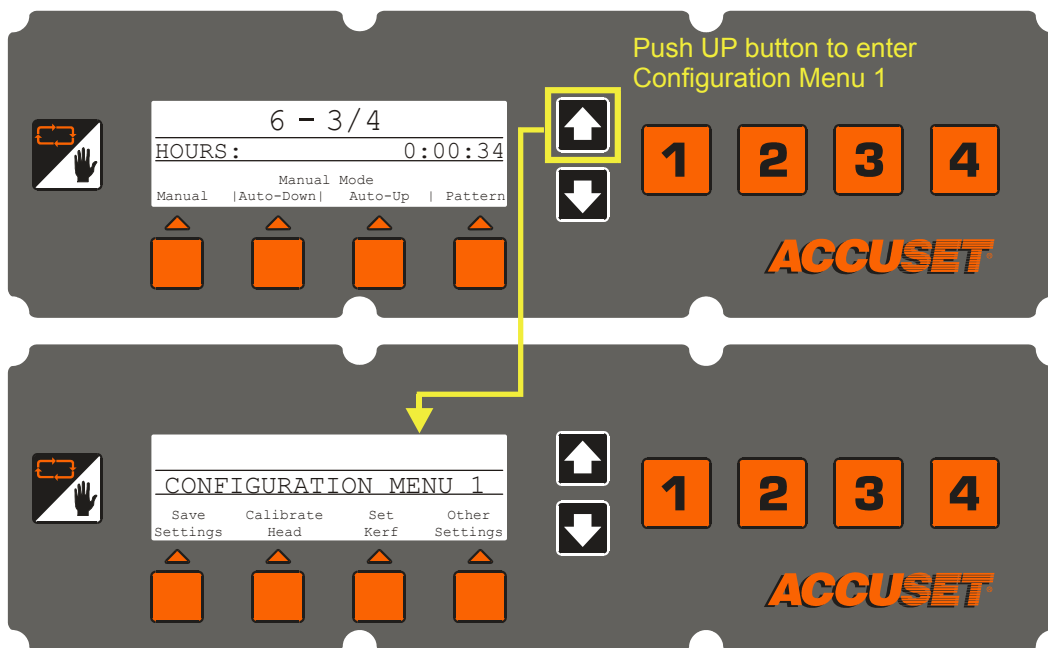

3H0821-1

FIG. 2-2

- **Make sure the Accuset is programmed for the appropriate sawmill model.** The control is programmed for DC mills by default from the factory. If you are operating an AC electric sawmill (LT60HD/70HD E25), change the program setting by choosing the “Other Settings” button from Configuration Menu #1. Push the “Change Lan-

2 Setup & Operation

Control Setup

guage” button. Push the “Other Languages” button twice to scroll to Change Language menu #3.

See Figure 2-3. Push the unlabeled button (third from the left) to display the “Debug” menu below. Push the “DC or AC Mode” button. The current mode will be displayed.

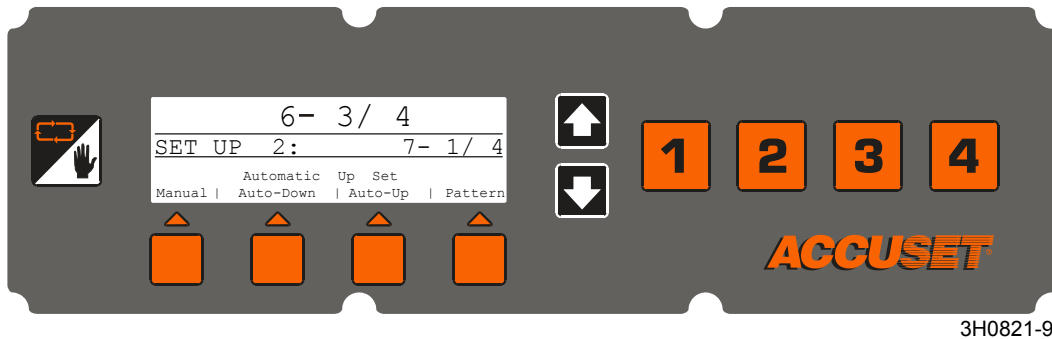

FIG. 2-3

See Figure 2-4. Push the Up button to change the mode to AC, then push “Save Now”. Press “Save Now” again to store the new mode setting.

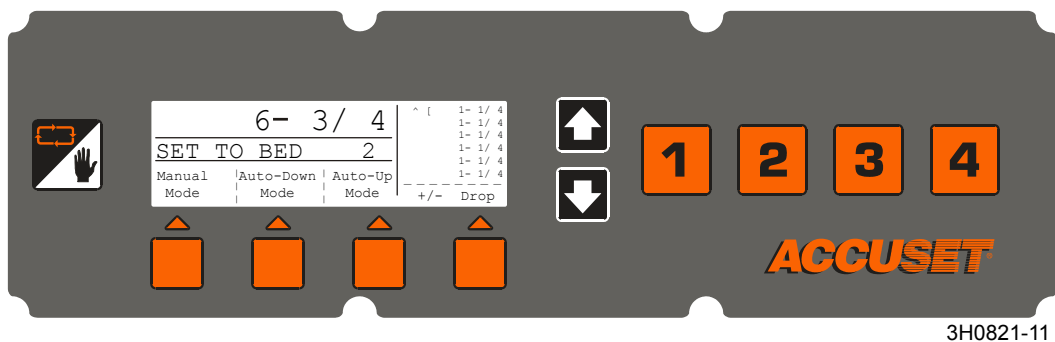

FIG. 2-4

- **Adjust Gradient.** If the Accuset is factory-installed, the Gradient Setting is already set to match the gradient of the transducer sensor (labeled "GRD" on the sensor). If the Accuset has been installed in the field, the transducer replaced or the Accuset control has been reset to Factory Settings, the Gradient Setting should be adjusted.

See Figure 2-5. To enter Configuration Menu 1, push the Up button while in Manual Mode. Push the button labeled "Calibrate Head", then the "Adjust Gradient" button to display the menu below.

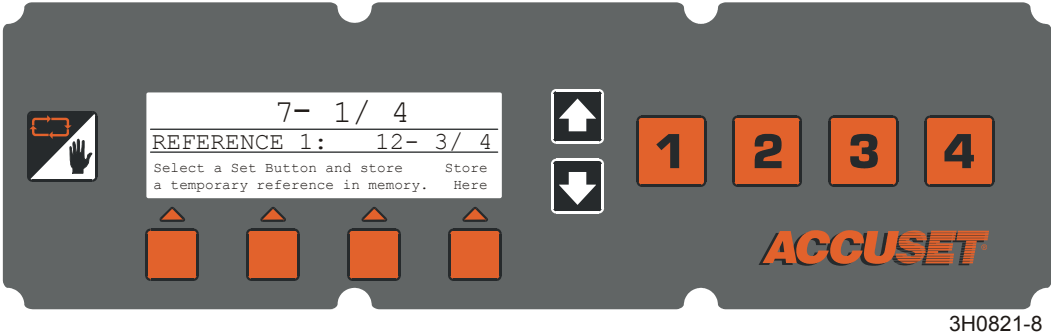

FIG. 2-5

See Figure 2-6. Push the Up or Down buttons until the Gradient Setting is the same as the sensor gradient shown on the sensor label (use the number labeled "us/in"). Push the Save Now button to store the new Gradient Setting. If you don't want to save the new setting and want to return to the previously stored Gradient Setting, push Exit Config and turn the key switch to the off (#0) position.

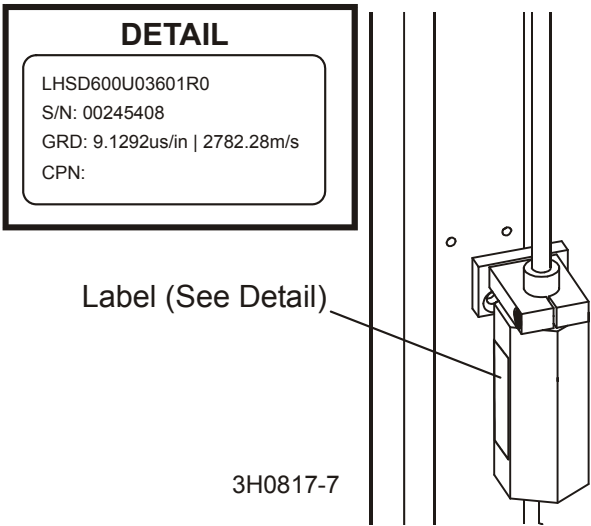

FIG. 2-6

- **Press At 12 Inches (or 305mm in metric mode).** The Accuset control should indicate the actual position of the blade above the bed rails. To check this setting, move the saw carriage so the blade is positioned above a bed rail. Raise the saw head until the blade is positioned 12" (305mm) by actual measurement from the bed rail. Measure from the top of the bed rail to the bottom of a down-set tooth of the blade. While in Manual Mode, push the Up button to enter the Configuration Menu. Choose Calibrate Head and press the button labeled "Press at 12 inches" (or "Press at 305mm"). The display will change to "Head Calibrated". Push the Save Settings button to store the new 12-inches setting and exit the Configuration Menu.
- **Adjust Offset.** Although you can use the Offset value to adjust the Accuset control, it is recommended that you use the Press At 12 Inches setting to make this adjustment. The Offset value is provided for diagnostic reasons and should not need to be adjusted.
- **After recalibrating the Accuset control,** check and adjust the inch scale on the saw head to match the value displayed on the control. Adjust the bottom saw head stop bolt all the way down. Move the saw head down until Accuset displays 3/4" and adjust the bottom saw head stop bolt up until it just touches the saw head.

2.1.3 Other Settings

Set Kerf. The Kerf setting is **optional**. The default kerf setting is '0'. You can use the kerf setting to automatically factor the blade thickness into the increment setting. Factoring the kerf into the program will allow you to saw boards that are the actual thickness of the programmed increment. For example, if kerf is set to '0' and you have programmed increments of 1 1/8", the resulting boards will be about 1 1/16" thick because Accuset did not factor the thickness of the blade. If you enter an accurate kerf value, the resulting boards will be 1 1/8". Whether or not to use the kerf setting is dependant on your sawing practices and application.

See Figure 2-7. While in Manual Mode, push the Up button to enter the Configuration Menu. press the "Set Kerf" button to display the menu below.

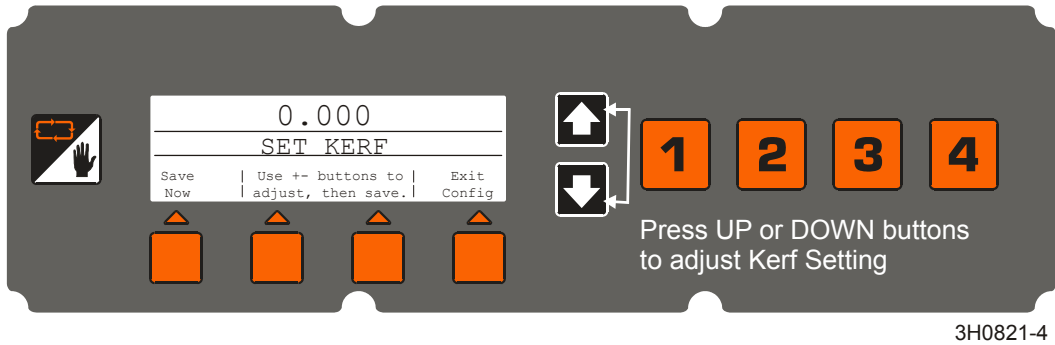

FIG. 2-7

See Table 2-1. Recommended kerf settings for various blades are provided below. These kerf setting values assume the teeth of the blade are set per factory specifications. If you prefer, a nominal kerf value of .125 (3 mm) can be entered and should be accurate enough for most applications.

| Blade Thickness | Blade Style | Kerf Setting |
|-----------------|-------------|----------------|
| .042 | 10S | 0.084 (2.2 mm) |
| .045 | 9S | 0.090 (2.3 mm) |
| | 10S | 0.095 (2.5 mm) |
| .055 | 10S | 0.111 (2.9 mm) |

TABLE 2-1

Push the Set Kerf button and use the Up and Down buttons to adjust the kerf setting. Pushing the Up and Down buttons simultaneously will scroll the kerf faster. Push the Save Now button to store the new Kerf Setting. If you don't use the Kerf Setting, be sure to include the thickness of the blade in your increment settings as described in [Section 2.2 Mode Selection](#).

2 Setup & Operation

Control Setup

See **Figure 2-8**. You can change other settings for the Accuset including the language used on the display, the unit of measure, PID values and analog limits. These settings are found in Configuration Menu 2. To display Configuration Menu 2, push the Up button while in Manual Mode to display Configuration Menu 1. Select Other Settings to display Configuration Menu 2.

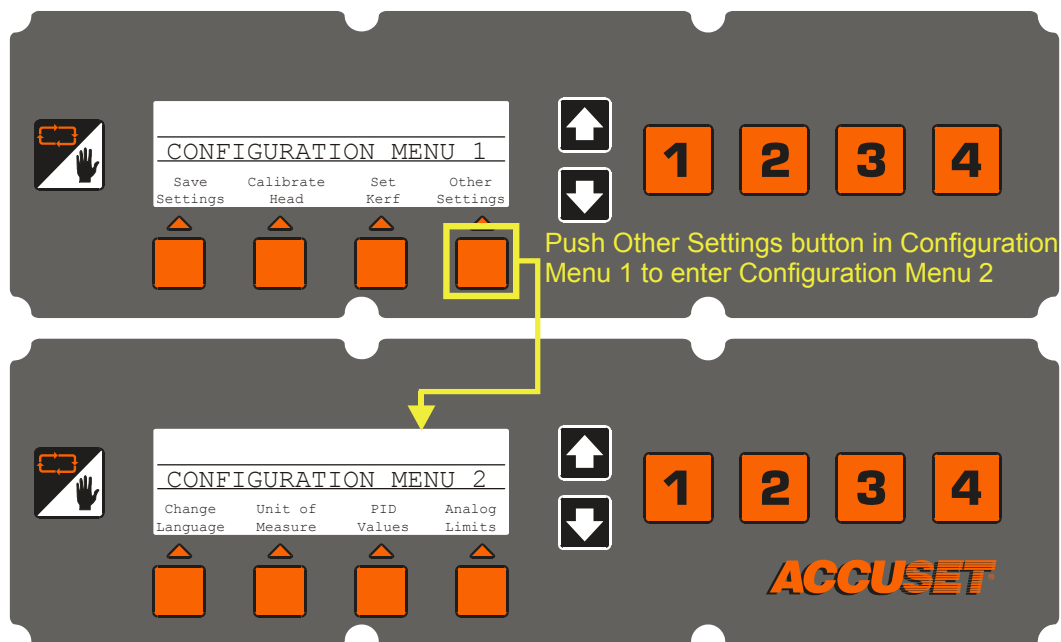

3H0821-2

FIG. 2-8

PID (Proportional - Integral - Differential) & Motor Deadband Values. These settings allow a technician to diagnose and fine-tune the Accuset control for various environmental factors. These settings are made at the factory and should not normally need adjusting by the operator.



IMPORTANT! Before adjusting the Accuset calibration settings, make sure the up/down chain is clean, lubricated and adjusted properly. Also check the saw head slide pads are adjusted properly and the mast rails are clean and lubricated.

See Figure 2-9.

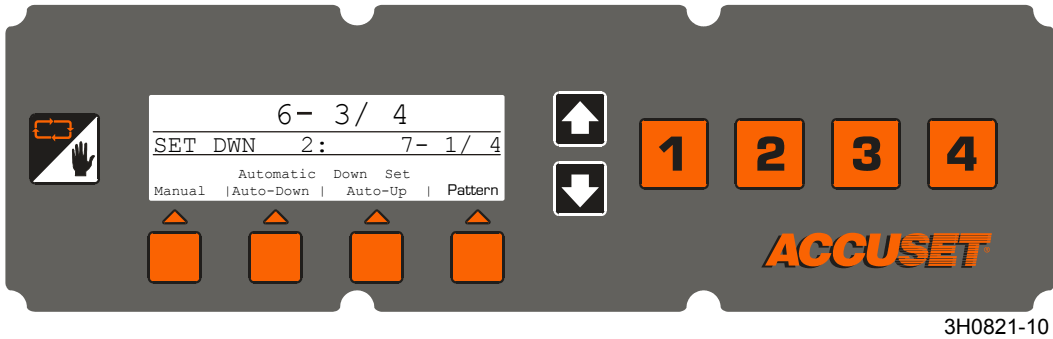

FIG. 2-9

See Table 2-2. To view the PID values, push the PID Values button. The factory default PID values are shown below:

| LT60HD/70HD Models | | |
|--------------------|--------------|-----------------------|
| Value | Default (DC) | E25 (AC) ¹ |
| PID PGU | 1500 | 1000 |
| PID PGD | 600 | 750 |
| PID IGU | 0 | 0 |
| PID IGD | 0 | 0 |
| PID DGU | 3000 | 0 |
| PID DGD | 3000 | 0 |
| MTR DBU | 20000 | 0 |
| MTR DBD | 8000 | 0 |

TABLE 2-2

¹ Setting the control to AC mode automatically sets the PID values for AC operation (See [page 2-2](#)).

- Proportional Gain (PGU and PGD):** The first value displayed is the Proportional Gain for the up direction (PGU). By default, the Up value is active as indicated by the "><" symbols. Use the up and down arrow buttons to adjust the value. Push the button labeled "Dwn" to activate the Down value (PGD) and adjust with the up and down arrow buttons as desired.
- Integral Gain (IGU and IGD):** To scroll to the next set of values, push the "Adjust gain" button. The Integral Gain will be displayed and the up (IGU) and down (IGD) values can be adjusted as described above.

2 Setup & Operation

Control Setup

- **Differential Gain (DGU and DGD):** Push the “Adjust gain” button again to display the Differential Gain values. Adjust the up (DGU) and down (DGD) values as described above.
- **Motor Deadband Bias (DBU and DBD):** Push the “Adjust gain” button a third time to display the Motor Deadband values. Adjust the up (DBU) and down (DBD) values as described above.

After adjusting all values, push the “Exit” button. Push the “Save Now” button to save any changes you made or press “Exit Config” to ignore any changes and return to the previously stored settings.

After making the desired PID Value adjustments, go to the desired Accuset mode. Test how the changes affect Accuset performance. If the new settings improve performance, push the Manual button to change to Manual Mode and push the Up button for Configuration Menu 1. Press the Save Settings button. If the new settings cause undesirable results, turn the key switch to the off (#0) position to return the PID Values to the previously stored settings.

NOTE: You can always return the Accuset to the original factory default values by resetting the AC or DC mode as described on [page 2-2](#).

Unit Of Measure. This setting allows you to choose what unit of measure to use for your Blade Height and Increment Settings. The default value is Fractional Inches (1/32”). You can change the Unit Of Measure to Decimal Inches (.0313”) or Millimeters (1 mm). Push the Save Now button to store the new Unit Of Measure setting. To return to the previously stored Unit Of Measure, push Exit Config and turn the key switch to the off (#0) position.

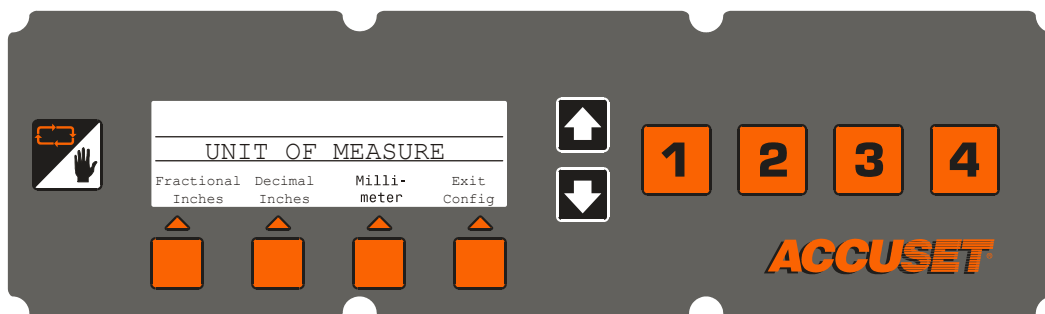

3H0821-6

FIG. 2-9

Change Language. You can choose the language used for the Accuset display. Push the Change Language button and choose the desired language. Push the Save Now (or language equivalent) button to permanently store the new Language setting. To return to the previously stored Language setting, push Exit Config and turn the key switch to the off (#0) position.

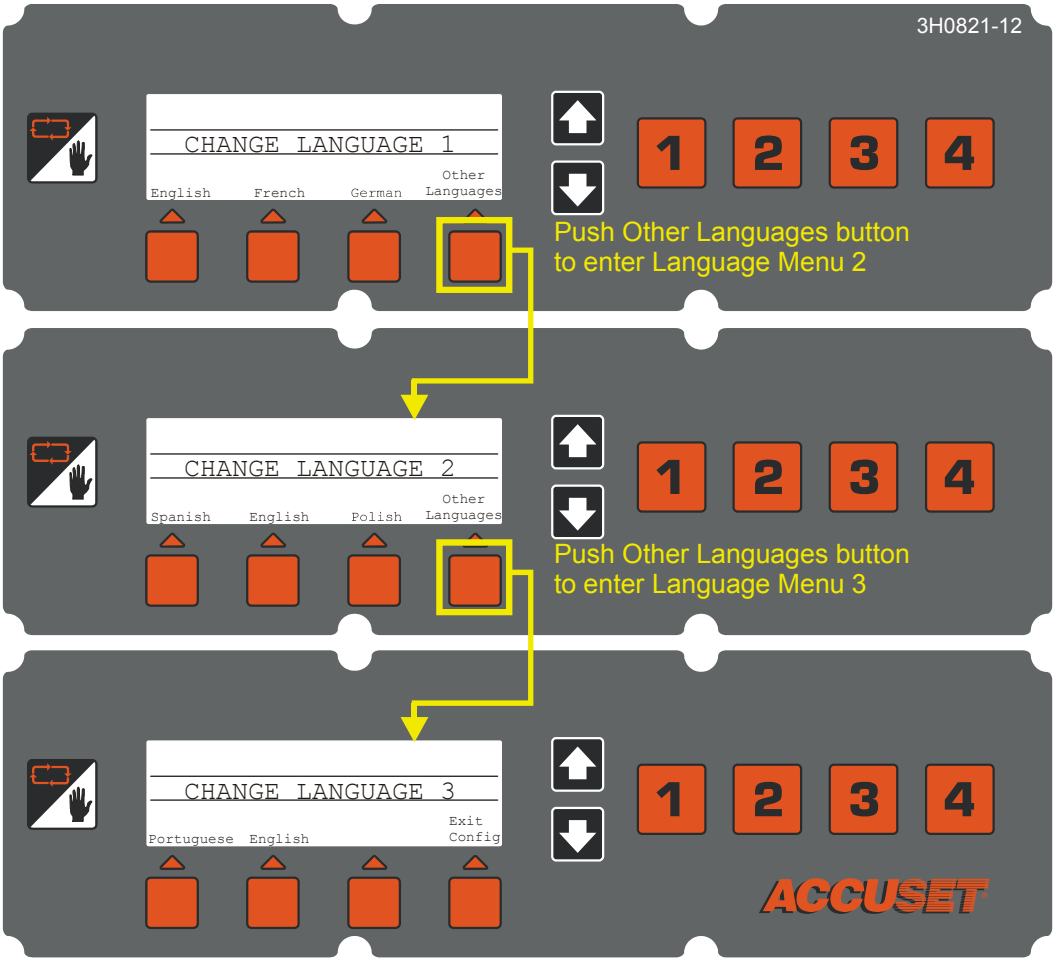

FIG. 2-9

Analog Limits. These settings are used for troubleshooting diagnostics and should not be adjusted by the operator unless directed to do so by a qualified Wood-Mizer service representative.

2.2 Mode Selection

See **Figure 2-10**. To select an Accuset mode, press the desired Mode Select button (Auto-Down, Auto-Up or Pattern) located under the display. Press the Manual Mode Select button to return the control to Manual Mode.

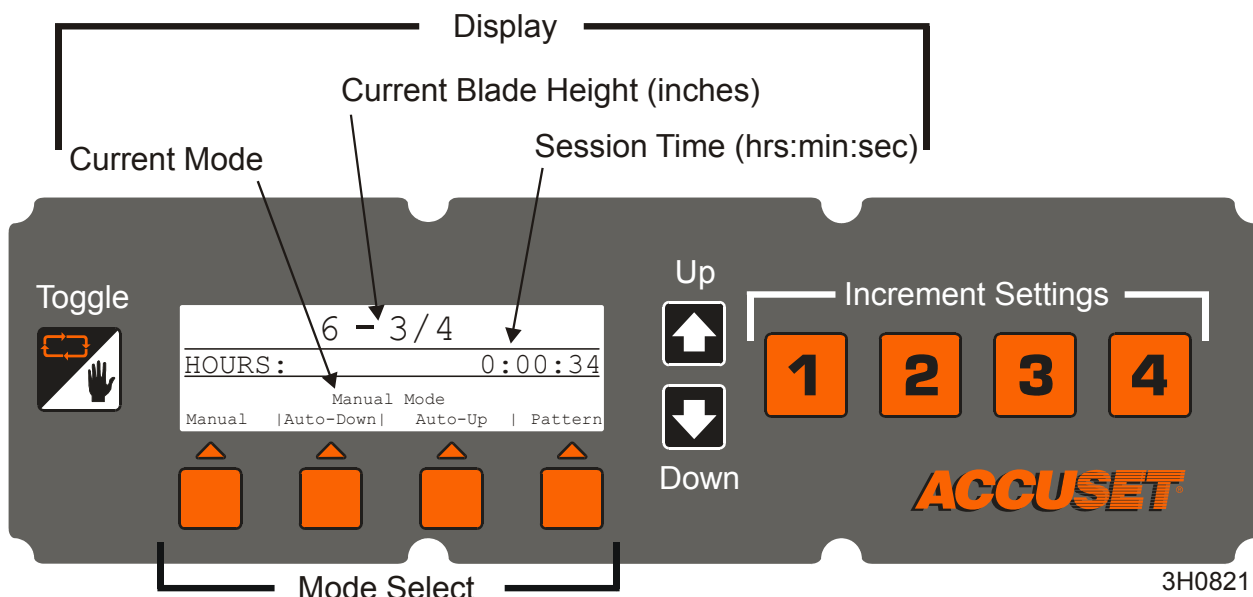

FIG. 2-10

Manual Mode - This mode allows you to use the up/down function of the sawmill as you normally would without the Accuset option. The Current Blade Height will continue to be displayed by the Accuset control.

Auto-Down Mode - This mode *references the current blade height* and allows you to choose an increment to move the blade *down*. The Accuset will automatically move the saw head down and stop at the next increment when you push the drum switch down. You can store sixteen different increment levels using the four numbered Increment Settings buttons. Each button stores four adjustable increment settings. Push button #1 once for setting #1. Push button #1 a second time for setting #5, etc...

Auto-Up Mode - This mode *references the current blade height* and allows you to choose an increment to move the blade *up*. The Accuset will automatically move the saw head up and stop at the next increment when you push the drum switch up. Auto-Up mode is primarily used to raise the saw head in large increments when preparing to cut a new log or log that has been turned. This allows the operator to raise the saw head without having to hold the drum switch up, freeing the operator to perform other functions while the saw

head is being raised. The Increment Settings buttons work in the same manner as described in Auto-Down Mode.

NOTE: The sixteen increment settings apply to Auto-Down AND Auto-Up modes. If you change a setting in Auto-Down mode, it will also change when you are in Auto-Up mode.

Pattern Mode - This mode *references the bed surface* and allows you to program up to six different increments calculated up from the bed. The sixth (top) increment repeats itself up to the upper limit of the saw head travel. The bottom increment indicates the size of the remaining cant when the pattern is complete.

Reference Mode - This mode allows the operator to program up to four pre-set locations along the saw head travel. The factory default settings are at the bottom (3/4"), the location where the saw head is calibrated (12"), a location midway between the calibration and the top (24"), and the top (34 1/2").

2.3 Using Auto-Down Mode

See Figure 2-11.

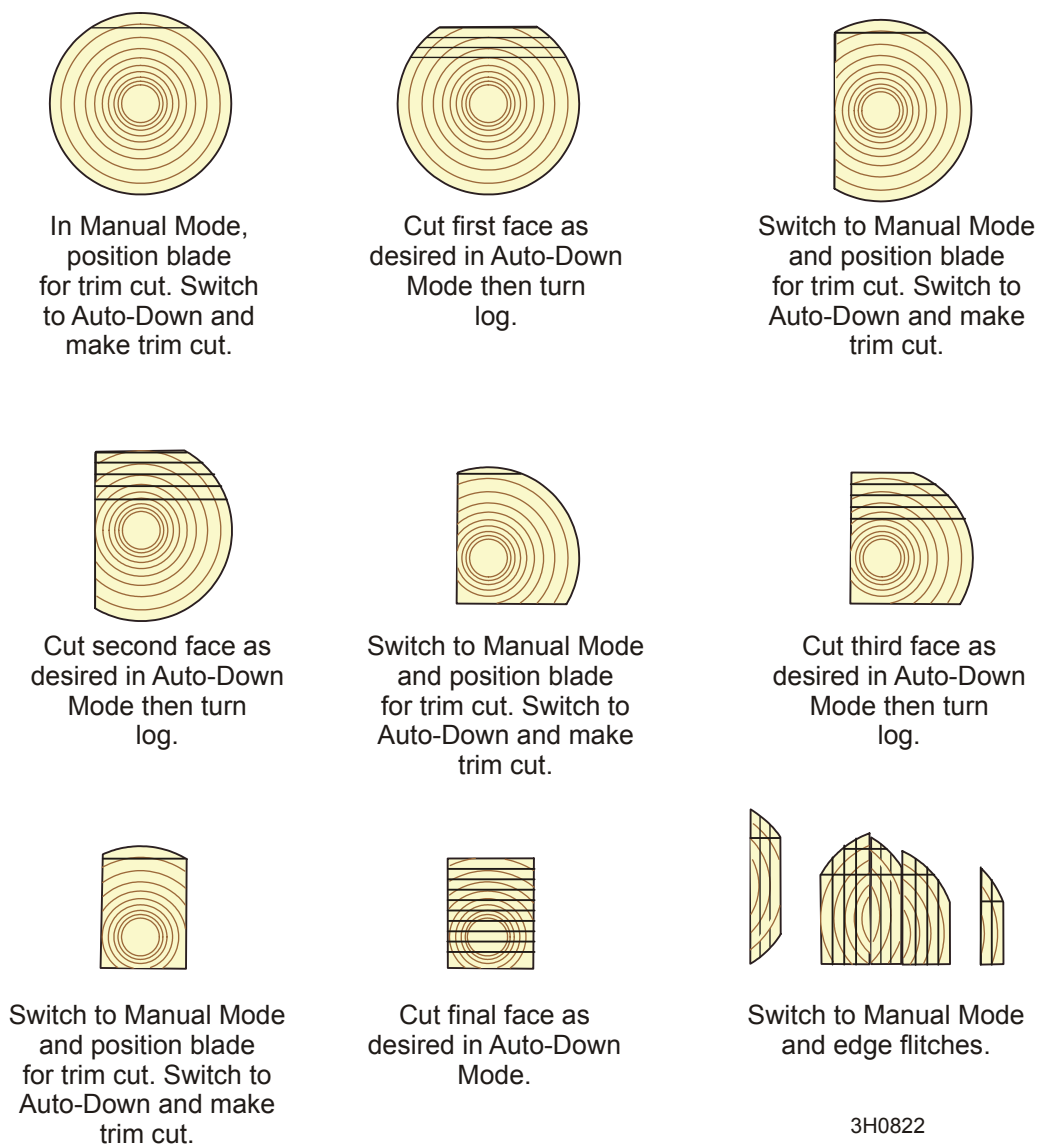

FIG. 2-11

Starting with a new log, position the saw head to make the first trim cut.

Push the Auto-Down button under the display. The first Increment Setting is displayed by default. Choose the desired increment setting by pushing the appropriate Increment Setting button.

To change an Increment Setting, select the desired setting number and push the Up or Down buttons until the desired Increment Setting is obtained. Pushing the Up and Down buttons simultaneously will scroll the settings faster. Remember to include blade kerf in your setting (i.e. If you want the finished boards to be 1" thick, set the increment to 1 1/8" to allow for typical blade kerf). The amount of kerf will depend on the thickness and tooth set of the blade you are using. The Accuset can be programmed with an automatic kerf setting if desired ([See Section 2.1.3](#)).

When you change an increment value, it is only temporarily stored. If the control is turned off, the settings will return to the factory defaults unless the new values are saved. To save the new increment setting, push the Manual Mode then push the Up button. The Configuration Menu will be displayed. Choose Save Settings then Save Now.

Example: To store 1 1/2" increment to the #7 increment setting, push Increment Selection button #3 twice to display setting #7 (default value for setting #7 is 7"). Push the Down button to adjust the setting to 1 1/2". While pushing the Down button, push the Up button to scroll faster. When you get close to 1 1/2", release both buttons. Push the Down button to fine tune the setting to exactly 1 1/2". Push the Manual Mode button. Push the Up button to display the Configuration Menu. Push the Save Settings button. Push the Save Now button. Increment setting #7 is now 1 1/2" until you change the setting to something else.

Push the Auto-Down button to return to Auto-Down Mode if necessary. Make the trim cut, raise the saw head and return the carriage to the front of the log.

Push the up/down drum switch down and release. The saw head will automatically bypass the setting where the first cut was made and stop at the next setting determined by the increment you have chosen.

Make a cut, raise the saw head and return the carriage for the next cut. Push the up/down drum switch down and release. The saw head will stop at the setting for the next cut. Repeat this procedure down this face of the log as desired.

Turn the log as you normally would and push the Manual Mode button to place the Accuset in Manual Mode.

Position the saw head for the trim cut and push the Auto-Down button to return to Auto-Down Mode. Make the trim cut, raise the saw head and return for the next cut. Use the same procedure as described above to cut each side of the log until done.

NOTE: Anytime a trim cut is necessary, you can push the Manual button to enter Manual Mode. Position the saw head for the trim cut and push the Auto-Down button to return to Auto-Down Mode. Accuset will reference the new blade position and stop at the next setting determined by the increment you have chosen.

2.4 Using Auto-Up Mode

Auto-Up Mode works exactly the same as Auto-Down explained above except it controls the saw head movement in the up direction.

2.5 Using Pattern Mode

Starting with a new log, position the saw head at the front end of the log.

Push the Pattern button under the display. Pattern Setting #1 is the factory default. Choose the desired pattern setting (1 - 16) by pushing the appropriate Increment Setting button.

In Pattern mode, a list of six increments is shown on the display. These increments are referenced from the bed rail. The bottom increment represents the distance from the bed rail for the last cut. Each increment in the list can be adjusted as desired. The top increment repeats as necessary depending on how high you raise the saw head.

As you raise or lower the saw head, symbols in the pattern increment list indicate where the blade is located in reference to the pattern. When the blade is above the top setting a ^ symbol appears next to the top increment to indicate you are in the repeating top increment. After you lower the blade and reach the last top increment, a + symbol will appear to indicate you are close to the next setting. When the blade reaches the increment setting, a - symbol will appear next to that setting.

To change any of the six pattern increments, push the +/- Drop button (below the pattern increment list) to scroll to the desired increment. The increment that is active is indicated with a > symbol. As you scroll to each increment, the previous increment setting will automatically be copied to the active increment. Push the Up or Down buttons until the desired increment is obtained. Remember to include blade kerf in your setting (i.e. If you want the finished boards to be 1" thick, set the increment to 1 1/8" to allow for typical blade kerf). The amount of kerf will depend on the thickness and tooth set of the blade you are using. The Accuset can be programmed with an automatic kerf setting if desired ([See Section 2.1.3](#)).

Push the +/- Drop button to move to the next pattern increment and adjust as desired. After the bottom increment setting is adjusted as desired push the +/- Drop button to exit pattern edit mode (> symbol will no longer be displayed).

To store the new pattern increment settings, push the Manual Mode button then push the Up button. The Configuration Menu will be displayed. Choose Save Settings then Save Now.

Example: To edit the pattern increment settings for the #4 pattern setting, push Increment Selection button #4 once to display pattern setting #4 (the factory default value for pattern setting #4 is 2"). Push the +/- Drop button to enter pattern edit mode. The top pattern increment is now indicated with a > symbol. Push the Down button to adjust the setting to 1 1/8". While pushing the Down button, push the Up button to scroll faster. When you get close to 1 1/8", release both buttons. Push the Down button to fine tune the setting to exactly 1 1/8". Push the +/- Drop button again to move the next pattern increment. The

setting will automatically be copied from the previous setting to 1 1/8". Repeat for the third pattern increment. Exit pattern edit mode by pushing the Manual button. Save the new pattern setting by pushing the Up arrow button to enter Configuration Menu #1. Press the Save Settings button, then the Save Now button. Push the Pattern button to return to Pattern Mode and push Increment Selection button #4.

The top three pattern settings should now be 1 1/8" and the bottom three pattern settings should be 2".

Push the Manual Mode button and raise the saw head so the blade is positioned near the top of the log. Push the Pattern button to return to Pattern Mode.

Push the up/down drum switch down and release. The saw head will automatically stop at the first setting determined by the top pattern increment.

Make a cut, raise the saw head and return the carriage for the next cut. Push the up/down drum switch down and release. The saw head will stop at the setting for the next cut. Repeat this procedure down this face of the log as desired.

Turn the log as you normally would and push the Manual Mode button to place the Accuset in Manual Mode.

Raise the saw head so the blade is positioned near the top of the log and push the Pattern button to return to Pattern Mode. Make the cut, raise the saw head and return for the next cut. Use the same procedure as described above to cut each side of the log until done.

Auto-Bump Feature: The auto-bump feature is used to move the blade up a particular distance after each cut by simply bumping the up/down drum switch in the up direction. This feature is available only when using pattern button #1 (memory positions #1, #5, #9 & #13). Pattern buttons 2, 3 & 4 continue to require manual raising of the blade if desired.

To use the auto-bump feature, program the desired pattern in any of the four memory positions of button #1. The bump-up value used is the increment of AutoUp or AutoDown that you last viewed. To set the bump-up value, place Accuset in AutoUp or AutoDown mode and program an interval (example: 1/4") into any of the 16 available memory positions. Return Accuset to Pattern Mode. Now when the drum switch is moved up and released the blade will rise 1/4" and stop.

2.6 Using Reference Mode

While in Manual Mode, push the Toggle button to enter Reference Mode.

Push one of the four Increment Setting buttons to select a reference. Factory defaults for buttons 1 through 4 are 3/4", 12", 24" and 34 1/2". Push the up/down drum switch in the appropriate direction to start the saw head toward the reference position. If the saw head is already above the position and you push the drum switch up, Accuset will return to Manual Mode. Likewise, if the saw head is below the reference position and you push the drum switch down, Accuset returns to Manual Mode.

When the saw head reaches the target reference position, Accuset will return to Manual Mode.

To change the stored setting for any of the four buttons, move the saw head to the desired position. Press the Toggle button to enter Reference Mode. Push the button you wish to store the setting and then push "Store Here". Push the Toggle button to return to Manual Mode.

You can also change a setting by selecting one of the four Increment Setting buttons and changing the setting by using the Up and Down arrow buttons. Push the "Store Here" button to store the new setting.

NOTE: The new reference setting is only stored in temporary memory and will return to the default value when the Accuset is powered off and back on. To permanently store the new setting, enter Configuration Menu #1 and push the "Save Settings", then the "Save Now" button. Accuset will now keep the new setting until you readjust it or reset the Accuset to factory defaults.

SECTION 3 ACCUSET TROUBLESHOOTING



STOP! Be sure you have performed the preliminary troubleshooting procedure before troubleshooting a specific electrical system. This will save you a lot of time wasted troubleshooting the wrong system!

Before troubleshooting the Accuset, first be sure all components are properly installed. This is especially important if you have recently replaced a component. Recheck that the component is properly installed and connected. If any maintenance procedures that might affect Accuset performance were performed immediately before a problem developed, check that the procedures were performed properly. Adjustments to the up/down chain, vertical mast slide pads and up/down drive belt may affect Accuset performance. Sawmill components such as covers and guards that might interfere with Accuset wiring should also be checked.

This troubleshooting section was developed assuming you have isolated the problem to the Accuset option. Problems with the sawmill battery/charging system, circuit breakers, solenoids and up/down system can affect the Accuset option. Refer to the sawmill troubleshooting information to solve problems with these components. A list of common Accuset problems is provided below.

3.1 Common Problems

1 Accuset display remains blank. Most commonly happens when Accuset is not powered, the LCD contrast is not adjusted properly or the transducer is not providing a proper value when the control is first turned on. [See Section 3.2 Accuset Display Problems](#) for instructions for checking and replacing the Accuset front panel.

2 Accuset display is black. Most commonly happens when the LCD contrast is not adjusted properly. Check the display contrast before replacing the front panel.

Adjust the display contrast if necessary ([See Section 2.1.1 Contrast Adjustment](#) of the Accuset manual for instructions). If it is not possible to adjust the display contrast, check the transducer connections. If the transducer connections are good, replace the front panel ([See Section 3.2.1 Control Panel Replacement](#)).

3 Accuset display shows two horizontal lines (Rev. A.00 - A.03 only). This problem can be caused by bad transducer cable connections.

At the transducer, check if the cables are plugged properly. Tighten the cable connections if necessary.

If the cable connections are tight and the problem remains, inspect the transducer cables for damage. Replace the transducer cables if necessary.

Perform the Accuset reset, if the transducer cable connections are okay and plugged properly. [See Section 3.2.2 Resetting the Accuset](#) for instructions. If the display still shows two horizontal lines after resetting the Accuset, call Customer Service for assistance.

With Accuset in Manual Mode and activating the up/down drum switch...

4 Accuset does not make saw head move up and down. Check the red control lights located at the rear of Accuset and power box control panels ([See Section 3.3 Up/Down Control Lights](#)), to determine the cause for this problem.

5 Saw head does not move up but moves down. Check the upper row of lights at the back of Accuset and power box control panels. [See Section 3.3 Up/Down Control Lights](#) for instructions.

If the lights are okay, reset the Accuset ([See Section 3.2.2 Resetting the Accuset](#)). If the saw head still does not move up, replace the Accuset front panel.

6 Saw head does not move down but moves up. Check the lower row of lights at the back of Accuset and power box control panels. [See Section 3.3 Up/Down Control Lights](#) for instructions.

If the lights work properly, reset the Accuset ([See Section 3.2.2 Resetting the Accuset](#)). If the saw head still does not move down, check the fet transistor bridge by using the DC/AC Drv Debug selection in the Debug menu (See Section xxx). If the test shows the bridge is good, replace the Accuset front panel.

7 Accuset displays illegible characters. First reset the display by turning the keyswitch off (#0) and back on again. Before replacing the front panel, check the language option. [See Section 2.1.3 Other Settings](#) of the Accuset operator's manual. Change the language as needed. If the language is not a cause of the problem, reset the Accuset to Factory Settings ([See Section 3.2.2 Resetting the Accuset](#)). If the display continues to show the problem, replace the Accuset front panel.

8 Accuset display reads X/12 dimensions (Rev. A.00 - A.03 only). When this problem occurs, turn the key switch to the off (#0) position. Turn the key switch to the on (#1) or accessory (#3) position. Check if the display works properly. If the display continues to show the problem, reset the Accuset to Factory Settings ([See Section 3.2.2 Resetting the Accuset](#)). Replace the Accuset front panel, if the display still indicates incorrect dimensions.

9 Accuset makes inaccurate blade drops. This may be caused by variances in friction characteristics. Make sure the up/down chain is clean, lubricated and adjusted properly. Also check if the saw head slide pads are adjusted properly and the mast rails are clean and lubricated ([See Section 3.4 Accuracy Problems](#)).

10 Accuset switches from Pattern or Auto Mode to Manual Mode without pressing any buttons. Commonly happens when battery power is low, causing Accuset to reset. Check the battery cable connections. Recharge or replace the battery if necessary. If the battery is good, check the power cable connections in the Accuset front panel. Make sure all connections are tight and free of corrosion.

If all the power connections appear to be okay and the Accuset still switches modes without pressing any buttons, replace the Accuset front panel.

11 Accuset does not switch from Manual Mode to Pattern Mode (Rev A.00 - A.03 only). When this happens, turn the key switch to the off (#0) position. Turn the key switch to the on (#1) or accessory (#3) position. Check if the Accuset works properly. If the problem reappears, reset the Accuset to Factory Settings ([See Section 3.2.2 Resetting the Accuset](#)). Replace the Accuset front panel if necessary.

12 Accuset buttons do not work properly. Before replacing the control panel, turn the key switch to the off (#0) position. Turn the key switch to the on (#1) or accessory (#3) position and check if the buttons work properly. If the problem remains, check for a weak battery. If the battery is good and the control has been reset by powering off and back on and the buttons still do not function properly, replace the Accuset front panel.

13 Accuset display dimensions are not stable when engine is running and the saw-head does not move up and/or down. Most commonly happens when the transducer wire connections are loose. Check the transducer wires. Tighten the connections securing the transducer cables if necessary. If no problems are found with the wire connections, call Customer Service for assistance.

3.2 Accuset Display Problems

The Accuset display remains blank when the Accuset control box is not powered or its front panel is defective. Check the power light before replacing the control panel.

To check the power light, remove the eight screws securing the Accuset front panel. Remove the front panel from its original location without disconnecting the wires. Turn the key switch to the on (#1) or accessory (#3) position.

See Figure 3-1. The rear of the Accuset front panel located in the control box is shown below.

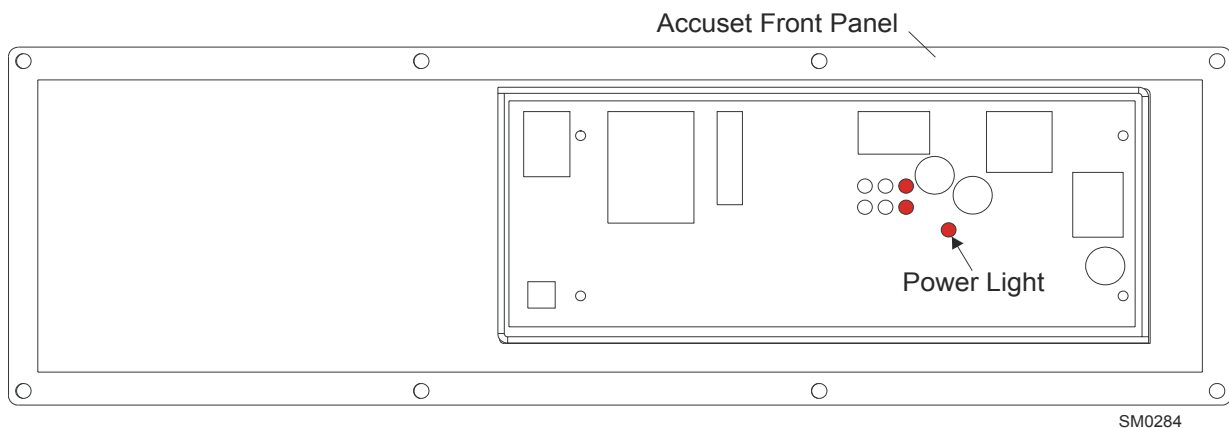

FIG. 3-1

If the power light is on, check the display contrast. Adjust the display contrast if necessary. [See Section 2.1.1 Contrast Adjustment](#) of the Accuset manual for instructions. Perform the Accuset reset, if the display contrast can not be adjusted. [See Section 3.2.2 Resetting the Accuset](#) for instructions. Replace the control panel, if the display remains blank after resetting the Accuset.

If the power light is off, check the Accuset wire connections. Wiggle the wire connections to check if the power light flickers. Tighten the wire connections if necessary. Check the up/down circuit breaker located in the operator's control box, if the light is still off. Reset the up/down circuit breaker as needed. If the circuit breaker is okay, replace the Accuset control panel.

3.2.1 Control Panel Replacement

1. Turn the key switch to the off (#0) position and remove the key.
2. Remove the eight screws holding the control panel to the Accuset control box.
3. Unplug the wire connections at the back of the control panel and remove the front panel.
4. Install the new control panel to the Accuset control box. Make sure all the wires are tight and plugged properly.
5. Secure the control panel to the Accuset control box with the eight previously removed screws.

3.2.2 Resetting the Accuset

To reset the Accuset to Factory Settings:

1. Turn the key switch to the off (#0) position.
2. Press and hold the Up and Down buttons.

See Figure 3-2.

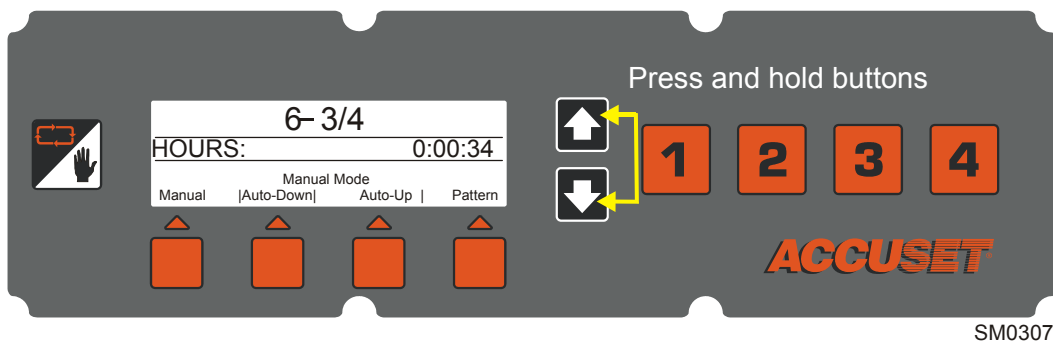

FIG. 3-2

3. Turn the key switch to the on (#1) or accessory (#3) position.
4. After being reset, the display will be completely dark or light. Turn the key switch off (#0) and back on again to reset the display.

IMPORTANT: Always readjust all the Accuset settings after resetting the unit. [See Section 2.1 Control Setup](#) of the Accuset manual for instructions.

3.3 Up/Down Control Lights

The up/down control lights are located on the back side of the Accuset front panel, next to the power light. To access the control lights, remove the eight screws securing the Accuset front panel. Remove the control panel from its original location without disconnecting the wires. Turn the key switch to the on (#1) or accessory (#3) position to check the control lights for operation.

The properly working control lights change while pushing the up/down drum switch located on the right side of the sawmill control box. When the up/down drum switch is in the neutral position, only the BR and BL lights should be on.

See Figure 3-3. Only the BR and BL lights are on when the up/down drum switch is not in use.

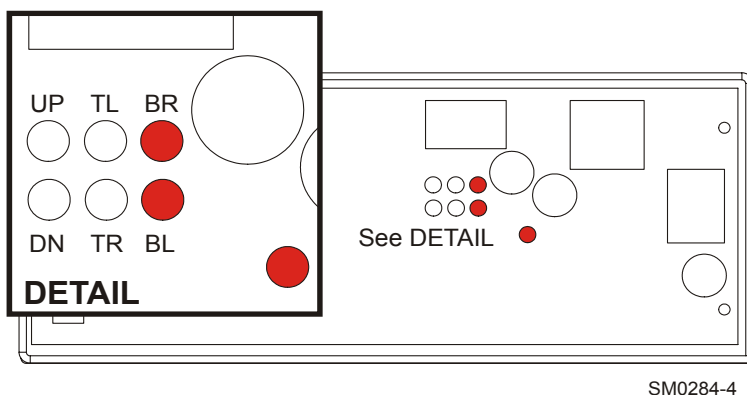

FIG. 3-3

If the Accuset works properly and the up/down drum switch is pushed forward to move the saw head up, only the UP, TL, and BR lights come on.

If the Accuset works okay and the up/down drum switch is pushed down to move the saw head down, only the DN, TR, and BL lights come on.

See below to determine the cause for your problem.

- 1** If the lights work properly while pushing the up/down drum switch, inspect the wire connections at the up/down motor leads. Remove the motor leads and check if the problem remains. Reconnect and tighten the wire connections. If the wire connections are not a cause for the problem, check the up/down motor brushes. Replace the motor brushes as needed. If the up/down motor brushes are okay, perform the MOSFET test ([See Section 3.3.1 MOSFET Panel Test](#)). Replace the MOSFET panel if defective.
- 2** If the lights do not change when pushing the up/down drum switch, and the BL and BR lights are on when the up/down drum switch in the neutral position, check the up/down drum switch. Inspect and tighten the up/down drum switch wire connections. If the saw head does not move up, inspect the wire connections specific for UP direction. If the saw head does not move down, check the wire connections specific for DOWN direction. Replace the up/down drum switch if necessary. If the up/down drum switch is okay, check the accessory circuit breaker.

See Figure 3-4. The accessory breaker is located inside the operator's control box. Remove the circuit breaker panel from the control box to access the breaker.

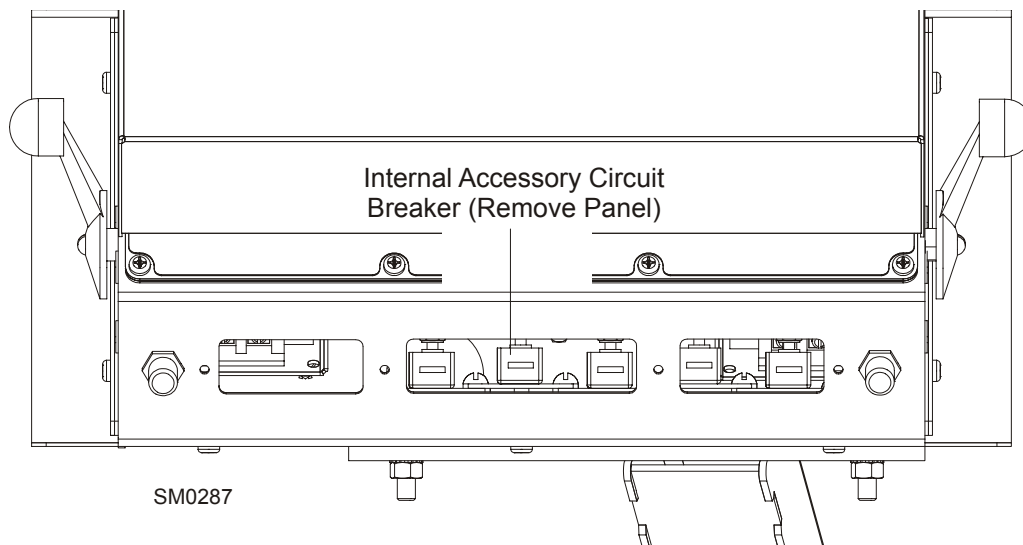

FIG. 3-4

Reset the accessory circuit breaker as needed. **NOTE:** If the breaker is still hot, you may not be able to reset it immediately. Allow the breaker to cool for a few minutes before attempting to reset.

3

Accuset Troubleshooting

Up/Down Control Lights

- 3** If the TL, TR, BR and BL lights do not change properly when pushing the up/down drum switch, reset the Accuset to Factory Settings ([See Section 3.2.2 Resetting the Accuset](#)). If the problem has not been eliminated, replace the Accuset front panel.

- 4** If the UP and DOWN lights do not change properly when pushing the up/down drum switch, check the MTRL and MTRR motor wire connections for correct location. Replace and tighten the wire connections as needed. If no problems are found with the wire connections, perform the MOSFET panel test ([See Section 3.3.1 MOSFET Panel Test](#)). If the MOSFET panel is okay, reset the Accuset to Factory Settings ([See Section 3.2.2 Resetting the Accuset](#)). If the UP and DOWN lights are still not functioning properly, replace the Accuset front panel.

- 5** If the UP and DOWN lights flicker when pushing the up/down drum switch, check the MOSFET panel ([See Section 3.3.1 MOSFET Panel Test](#)). Tighten the wire connections if necessary. If the MOSFET panel has been replaced before, check the MTRL and MTRR motor wire connections for correct location. If no problems are found with the wire connections, replace the MOSFET panel.

- 6** If all the up/down lights are off, check the power light at the rear of the Accuset front panel. If the power light is off [See Section 3.2 Accuset Display Problems](#) for instructions. If the power light is on, disconnect and check the MOSFET panel. [See Section 3.3.1 MOSFET Panel Test](#) to perform the MOSFET test. Replace the MOSFET panel as needed. If the MOSFET panel has been eliminated as a cause for the problem, perform the Accuset reset ([See Section 3.2.2 Resetting the Accuset](#)). If the problem remains, replace the Accuset front panel.

3.3.1 MOSFET Panel Test



WARNING! Before performing any service to the sawmill control box panel, turn the key to the OFF position, disconnect the negative battery lead, and remove all rings, watches, etc.... Failure to do so may cause serious injury and machine damage.

To perform the MOSFET panel test:

1. Turn the key switch to the off (#0) position and remove the key.
2. Remove the eight screws securing the MOSFET panel.
3. Disconnect all the wires and connectors from the rear of the MOSFET panel.
4. Remove the MOSFET panel from the sawmill. Make sure you can access the terminals located at the rear of the panel.

See Figure 3-5.

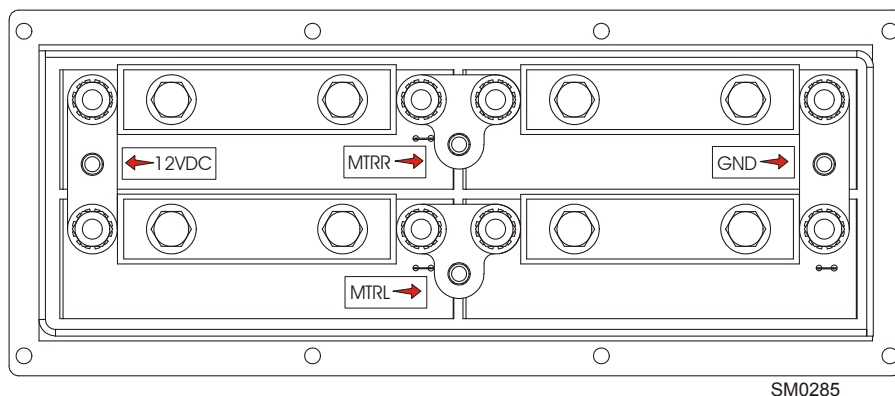

FIG. 3-5

5. Use the Ohm meter to check the resistance between the following terminals: GND and MTRR, GND and MTRL, 12VDC and MTRR, and 12VDC and MTRL. Check each of the readings. **NOTE:** High range resistance indicates that the MOSFET panel works properly. The MOSFET panel is defective and needs to be replaced if any of the readings shows continuity.

IMPORTANT! Be extremely careful when removing and reconnecting any wire connections.

3.3.2 Replacing the MOSFET Panel



WARNING! Before performing any service to the sawmill control box panel, turn the key to the OFF position, disconnect the negative battery lead, and remove all rings, watches, etc.... Failure to do so may cause serious injury and machine damage.

1. Turn the key switch to the off (#0) position and remove the key.
2. Remove the eight screws holding the MOSFET panel at the top of the Accuset control box.
3. Disconnect all the wires from the MOSFET panel terminals and remove the panel.
4. Replace the bad MOSFET panel with the new panel and connect the wires to the proper terminals.
5. Secure the new panel with the eight previously removed screws.

3.4 Accuracy Problems

The Accuset control can move the saw head accurately within $\pm 1/32$ " per move. To help determine the appropriate accuracy problem to troubleshoot, perform the following checks. Inspect all items listed below.

NOTE: Before you begin the Accuset inspection check if the Gradient Setting is set to match the gradient of the transducer sensor (labeled "GRD" on the sensor). The Gradient Setting must be adjusted if the Accuset has been replaced in the field, the transducer replaced or the Accuset has been reset to Factory Settings. The Accuset will not work properly if

- 1 Smooth overshoot.** Make sure the up/down chain is clean, lubricated and adjusted properly. Also check if the saw head slide pads are adjusted properly and the mast rails are clean and lubricated.

If the up/down chain, slide pads and mast rails are okay, increase the PID values. [See Section 2.1.3 Other Settings](#) of the Accuset operator's manual to adjust the settings properly. If the new settings do not improve performance, call Customer Service for assistance.

- 2 Jerky overshoot.** Check if the up/down chain, slide pads, and mast rails are clean and lubricated. Clean, lubricate and adjust if necessary. Check the PID values if adjusted correctly. [See Section 2.1.3 Other Settings](#) for default adjustments.

If the up/down chain is not a problem, call Customer Service for assistance.

- 3 Undershoot.** Check and decrease the PID values ([See Section 2.1.3 Other Settings](#) in the Accuset manual for instructions).

If the PID values are okay and set correctly. Clean, lubricate and adjust the up/down chain and slide pads. Check if the mast rails are clean and free of corrosion. If the problem remains, call Customer Service for assistance.

4 Replacement Parts

Sensor Assembly

SECTION 4 REPLACEMENT PARTS

4.1 Sensor Assembly

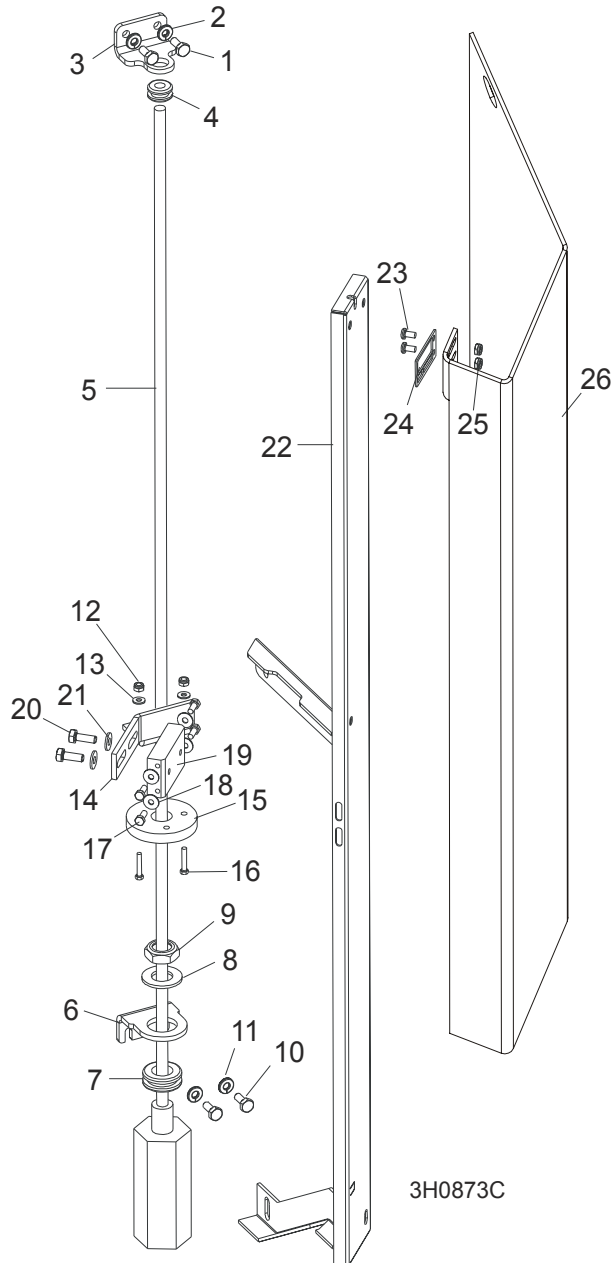

| REF | DESCRIPTION (◆ Indicates Parts Available In Assemblies Only) | PART # | QTY. | |
|-----|--|----------|------|--|
| 1 | BOLT, M6X20-8.8 HEX HEAD FULL THREAD ZINC | F81001-2 | 2 | |
| 2 | WASHER, 6.4 ZINC FLAT | F81053-1 | 2 | |
| 3 | BRACKET, UPPER SENSOR MOUNT | 035560 | 1 | |

| | | | | |
|----|---|------------|---|---|
| 4 | GROMMET, 3/8" ID RUBBER | 025248 | 1 | |
| 5 | TRANSDUCER, ACCUSET SERIES G | 052130 | 1 | |
| | ADAPTER ASSY, AC ACCUSET TRANSDUCER | 052296 | 1 | |
| 6 | BRACKET, LOWER SENSOR MOUNT | 035544 | 1 | |
| 7 | GROMMET, 3/4" ID RUBBER | 025247 | 1 | |
| 8 | WASHER, 3/4" ID NYLON | 025250 | 1 | |
| 9 | NUT, 3/4-16 NYLON LOCK | F05010-171 | 1 | |
| 10 | BOLT, M6X20-8.8 HEX HEAD FULL THREAD ZINC | F81001-2 | 2 | |
| 11 | WASHER, 6.4 ZINC FLAT | F81053-1 | 2 | |
| 12 | NUT, M4-B HEX NYLON ZINC LOCK | F81029-1 | 2 | |
| 13 | WASHER, 4.3 ZINC FLAT | F81051-2 | 2 | |
| 14 | BRACKET, SENSOR MAGNET MOUNTING | 035444 | 1 | |
| 15 | MAGNET, 3/4" ID FLOATING | 024876 | 1 | ◆ |
| 16 | SCREW, M4X25 8.8 HEX SOCKET HEAD CAP ZINC | F81011-3 | 2 | |
| 17 | SCREW, #10-24 X 1/2" HEX HEAD | F05004-18 | 4 | |
| 18 | WASHER, 5.3 ZINC FLAT | F81052-1 | 4 | |
| 19 | BLOCK, SENSOR MAGNET MOUNTING | 035440 | 1 | |
| 20 | BOLT, 1/4-20 X 3/4" FULL THREAD HEX HEAD | F05005-1 | 2 | |
| 21 | WASHER, 7.4 ZINC FLAT | F81056-11 | 2 | |
| | CABLE ASSEMBLY, 5-FOOT TRANSDUCER INTERFACE | 024868 | 1 | |
| 22 | MOUNT WELDMENT, SCALE PAINTED | 093365-1 | 1 | |
| 23 | SCREW, #10-24 X 3/8" SLOTTED PAN HEAD | F05004-3 | 2 | |
| 24 | POINTER, BLADE HEIGHT SCALE | 094821 | 1 | |
| 25 | NUT, #10-24 HEX SELF-LOCKING | F05010-14 | 2 | |
| 26 | GUARD, ACCUSET SENSOR PAINTED | 093457-1 | 1 | |

4 Replacement Parts

Control Assembly

4.2 Control Assembly

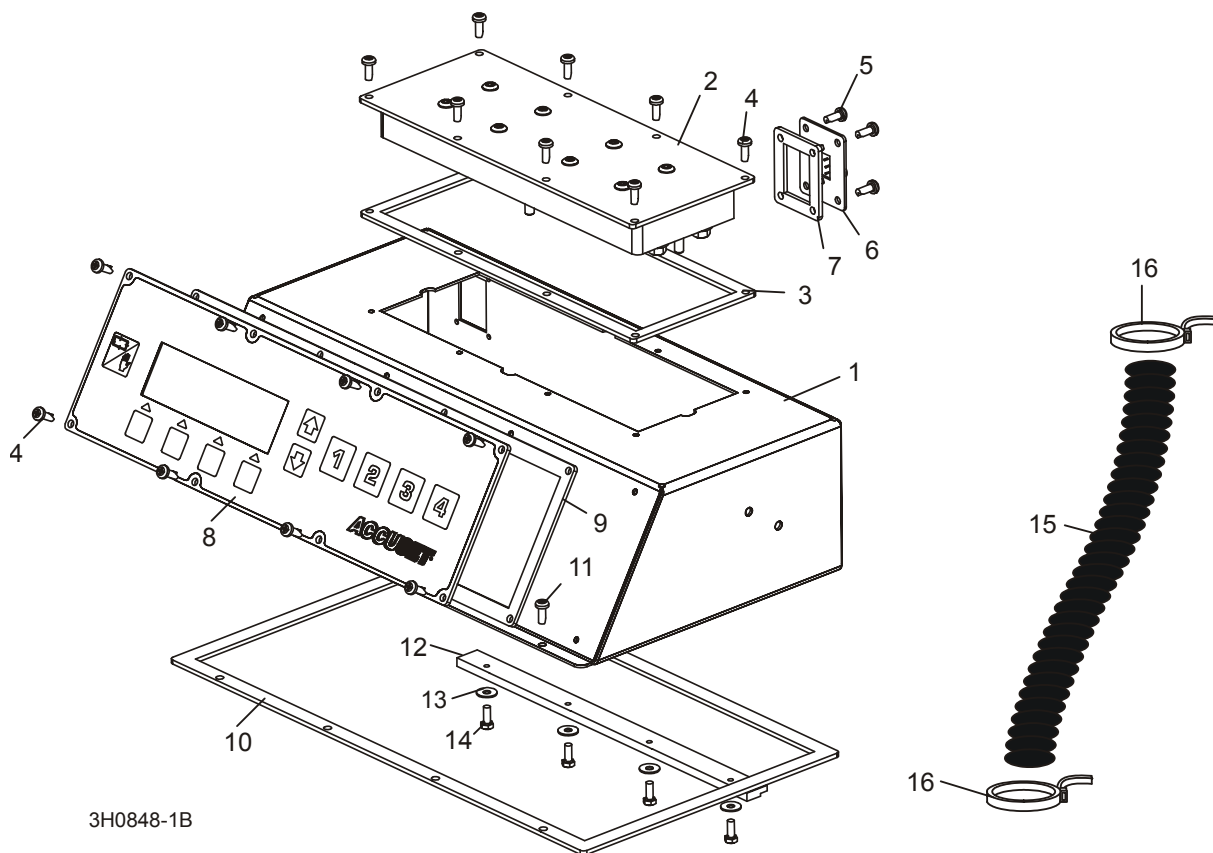

3H0848-1B

| REF | DESCRIPTION (◆ Indicates Parts Available In Assemblies Only) | PART # | QTY. | |
|-----|--|----------|------|---|
| | CONTROL ASSEMBLY, ACCUSET 2005 | | | |
| 1 | Box Weldment, Accuset Control | 28 78 | 1 | ◆ |
| 2 | Panel Assembly, Accuset Mosfet (DC Only) | 68 | 1 | |
| 2 | Panel Assembly, Accuset Mosfet (AC Only) | 33-1 | 1 | |
| 3 | Gasket, Accuset Mosfet Panel | 69 | 1 | |
| 4 | Screw, #10-24 x 1/2" Phillips Head | 15-17 | 16 | |
| 5 | Screw, #8-32 x 1/2" Phillips Head | 15-18 | 4 | |
| 6 | Harness Assembly, Accuset P4 | 67 | 1 | |
| 7 | Gasket, Accuset P4 Harness Panel | 71 | 1 | |
| 8 | Panel Assembly, Accuset Front (DC) | 26 | 1 | |
| 8 | Panel Assembly, Accuset Front (AC) | 27 | 1 | |
| 9 | Gasket, Accuset Front Panel | 70 | 1 | |
| | Instruction Sheet, Accuset Configuration | 92-1150 | 1 | |
| 10 | Gasket, Accuset Control Box | 80 | 1 | |
| | Cover Parts (See Section 3.3) | | | |
| 11 | SCREW, #10-24 X 3/8" PHILLIPS HEAD | 05-17 | 4 | |

Replacement Parts
Control Assembly

4

| | | | | |
|----|---|----------|-------|--|
| 12 | BRACKET, ACCUSET BOX HOLD-DOWN | 088829 | 1 | |
| 13 | WASHER, 5.3 ZINC FLAT | F81052-1 | 4 | |
| 14 | BOLT, M5X12-5.8 HEX HEAD FULL THREAD ZINC | F81000-5 | 4 | |
| 15 | CONDUIT, 5/8" SPLIT LOOM HIGH TEMP | 23-62 | 8 in. | |
| 16 | TIE WRAP, 3/16" X 6" BLACK UV | 89-3 | 2 | |

4 Replacement Parts

Cover Assembly

4.3 Cover Assembly

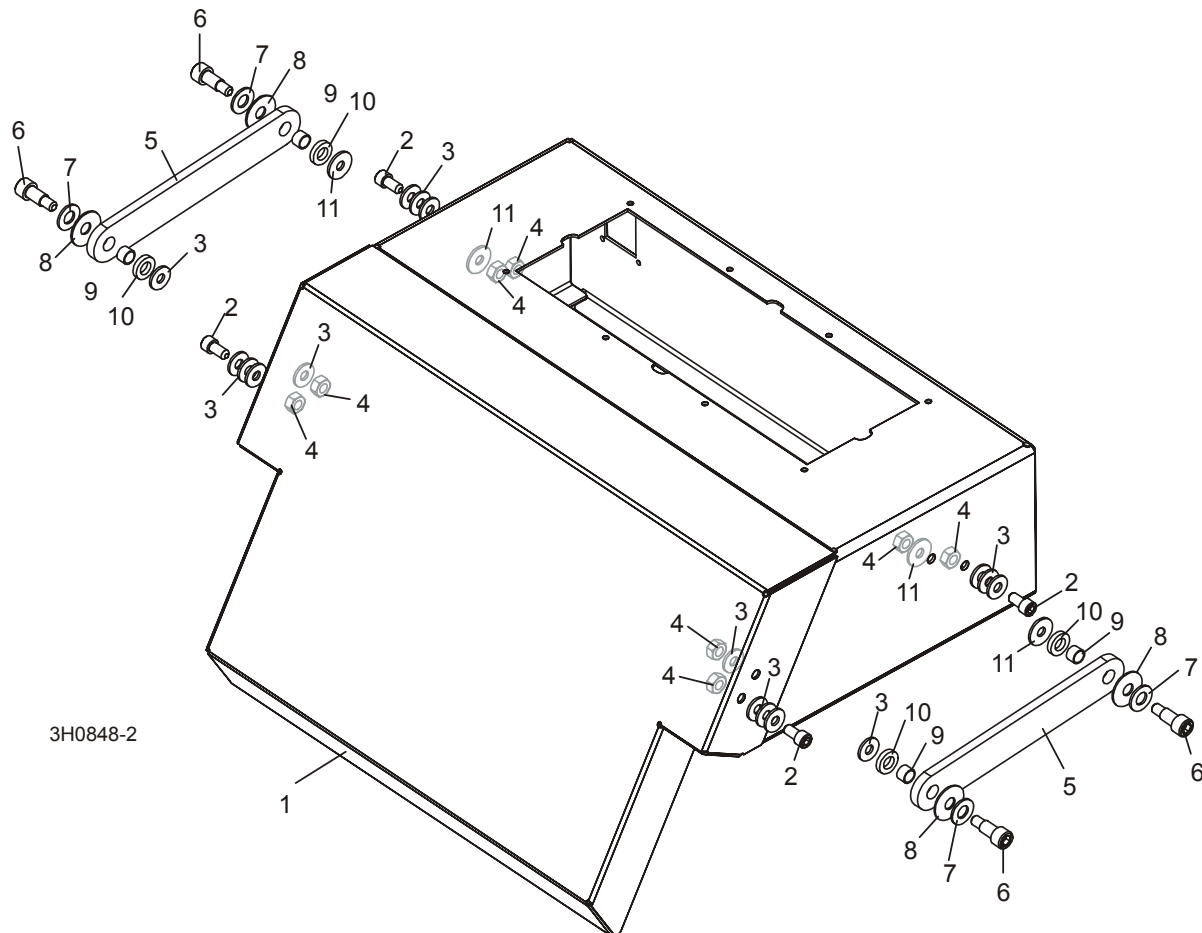

| REF | DESCRIPTION (◆ Indicates Parts Available In Assemblies Only) | PART # | QTY. |
|-----|--|--------|------|
| 1 | COVER, ACCUSET CONTROL | 03 | 1 |
| 2 | SCREW, 1/4-20 X 1/2" STAINLESS SOCKET HEAD | | |

INDEX

I

installation

- final 1-26
- pre-installation procedure 1-1
- sensor assembly 1-3, 1-9
- wiring (Standard Mills) 1-22
- wiring (Super Mills) 1-19
- wiring preparation 1-15

O

operation

- auto-down mode 2-13
- auto-up mode 2-15
- control description 2-11
- pattern mode 2-16
- reference mode 2-18

R

replacement parts

- control assembly 4-3
- cover assembly 4-5
- sensor assembly 4-1

S

setup

- up/down adjustment buttons 2-1

T

troubleshooting 3-1

- accuracy problems 3-12
- common problems 3-1
- display problems 3-4
- up/down control lights 3-7