

EA20 Motor

Safety, Operation, Maintenance & Parts Manual

LT40AC Series MH	rev. C1.00
LT40 Series AH	rev. C1.02



Safety is our #1 concern! Read and understand all safety information and instructions before operating, setting up or maintaining this machine.

November 1998

Form #971

Table of Contents

Section-Page

SECTION 1	SAFETY & GENERAL INFORMATION	1-1
1.1	Motor Operation	1-1
1.2	Electrical Operation.....	1-2
SECTION 2	OPERATION	2-1
2.1	Starting The Motor	2-1
SECTION 3	MAINTENANCE	3-1
3.1	Drive Belt Adjustment.....	3-1
SECTION 4	REPLACEMENT PARTS	4-1
4.1	How To Use The Parts List	4-1
4.2	Sample Assembly	4-1
4.3	Motor Starter Assembly	4-2
4.4	Motor Assembly	4-3
4.5	Motor Pulley Guards, EA20.....	4-4
SECTION 5	ELECTRICAL INFORMATION	5-1
5.1	Electrical Symbol Diagram	5-1
5.2	Main Electrical Box.....	5-5
5.3	Main Electrical Box Components	5-6
5.4	HD Electrical Box Diagram (HD Sawmills Only).....	5-7
5.5	HD Electrical Box Components (HD Sawmills Only).....	5-7
SECTION 6	BRAKE AIR GAP ADJUSTMENT	6-1

SECTION 1 SAFETY & GENERAL INFORMATION



IMPORTANT! This manual is provided as a supplement to the equipment manufacturer's manuals. This manual takes into account the specific use of engines on the Wood-Mizer sawmill. Only safety, maintenance, and operating procedures that are not provided by the manufacturer are supplied in this manual. Refer to the manufacturer's manual before attempting to operate this equipment.



This symbol calls your attention to instructions concerning your personal safety. Be sure to observe and follow these instructions. This symbol accompanies a signal word. The word **DANGER** indicates an imminently hazardous situation which, if not avoided, will result in death or serious injury. **WARNING** suggests a potentially hazardous situation which, if not avoided, could result in death or serious injury. **CAUTION** refers to potentially hazardous situations which, if not avoided, may result in minor or moderate injury to persons or equipment. Read all safety instructions before operating this equipment and observe all safety warnings!

1.1 Motor Operation



DANGER! Always be sure the blade is disengaged and all persons are out of the path of the blade before starting the engine or motor. Failure to do so will result in serious injury.



WARNING! Do not for any reason adjust the motor drive belts or belt support bracket with the motor running. Doing so may result in serious injury.

WARNING! Remove the blade before performing any motor service. Failure to do so may result in serious injury.



WARNING! Be sure the power feed switch is in the neutral position before turning the key switch to the (#1) or (#2) position. This prevents accidental carriage movement, which may cause serious injury or death.

1 Safety & General Information

Electrical Operation

1.2 Electrical Operation



DANGER! Make sure all electrical installation, service and/or maintenance work is performed by a qualified electrician and is in accordance with applicable electrical codes.

DANGER! Hazardous voltage inside the disconnect box, starter box, and at the electric motor can cause shock, burns, or death. Disconnect and lock out power supply before servicing! Keep all electrical component covers closed and securely fastened during mill operation.

SECTION 2 OPERATION

2.1 Starting The Motor

Engine Control Lights

See Figure 2-1. The following indicator lights are located on the sawmill control panel.

 *Key Switch Indicator:* Lights up when the key is in the (#1) position.

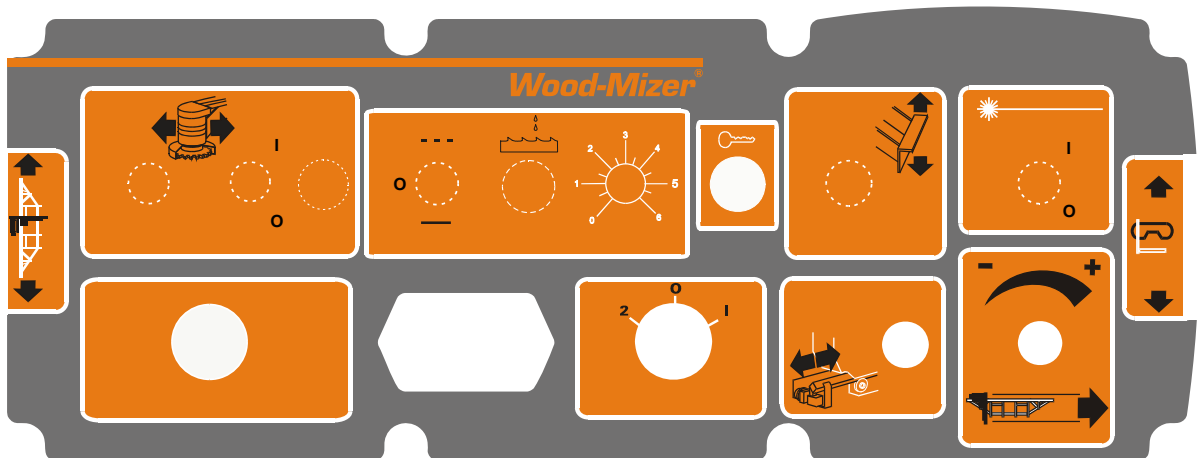

AC0022

FIG. 2-1

Motor Start



IMPORTANT! When starting the machine for the first time, check that main motor rotation direction is as indicated by the arrow located on the motor body (fan guard). If the rotation direction is incorrect, invert the phases in the phase inverter located in the power socket (electric box). Setting the phases in the phase inverter correctly will ensure correct rotation directions of all sawmill motors.



DANGER! Always be sure the blade is disengaged and all persons are out of the path of the blade before starting the engine or motor. Failure to do so will result in serious injury.



WARNING! Be sure the power feed switch is in the neutral position before turning the key switch to the (#1) or (#2) position. This prevents accidental carriage movement which may cause serious injury or death.

Turn the key switch to the start (#1) position and press the “START” button on the control panel.

Motor Shutoff

Turn the key switch to the off (#0) position and press the “STOP” button on the control panel.

SECTION 3 MAINTENANCE

 **This symbol** identifies the interval (hours of operation) which each maintenance procedure should be performed. "AR" signifies maintenance procedures which should be performed as required.

3.1 Drive Belt Adjustment

 Periodically check all belts for wear. Replace any damaged or worn belts as needed.

 **DANGER!** Do not for any reason adjust the drive belt support with the motor running. Always stop the motor before reaching or looking into the drive belt area.

SECTION 4 REPLACEMENT PARTS

4.1 How To Use The Parts List

- Use the table of contents or the index to locate the assembly that contains the part you need.
- Go to the appropriate section and locate the part in the illustration.
- Use the number pointing to the part to locate the correct part number and description in the table.
- Parts shown indented under another part are included with that part.
- Parts marked with a diamond (◆) are only available in the assembly listed above the part.

See the sample table below. Sample Part #A01111 includes part F02222-2 and subassembly A03333. Subassembly A03333 includes part S04444-4 and subassembly K05555. The diamond (◆) indicates that S04444-4 is not available except in subassembly A03333. Subassembly K05555 includes parts M06666 and F07777-77. The diamond (◆) indicates M06666 is not available except in subassembly K05555.

4.2 Sample Assembly				
REF	DESCRIPTION (◆ Indicates Parts Available In Assemblies Only)	PART #	QTY.	
	SAMPLE ASSEMBLY, COMPLETE (INCLUDES ALL INDENTED PARTS BELOW)	A01111	1	
1	Sample Part	F02222-22	1	
	Sample Subassembly (Includes All Indented Parts Below)	A03333	1	
2	Sample Part (◆ Indicates Part Is Only Available With A03333)	S04444-4	1	◆
	Sample Subassembly (Includes All Indented Parts Below)	K05555	1	
3	Sample Part (◆ Indicates Part Is Only Available With K05555)	M06666	2	◆
4	Sample Part	F07777-77	1	

To Order Parts:

- From Europe call our European Headquarters and Manufacturing Facility in Kolo, Poland at **+48-63-2626000** or **+48-3912-1319**. From the continental U.S., call **1-800-448-7881** to order parts. Have your customer number, vehicle identification number, and part numbers ready when you call.
- From other international locations, contact the Wood-Mizer distributor in your area for parts.

4.3 Motor Starter Assembly

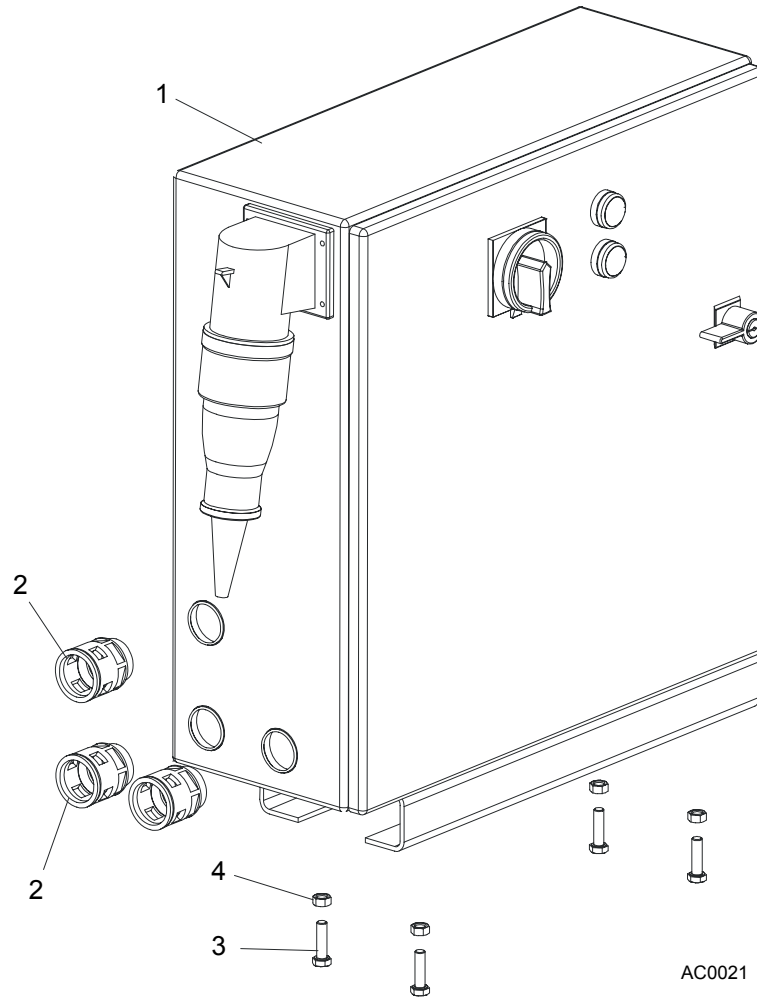

REF	DESCRIPTION (◆ Indicates Parts Available In Assemblies Only)	PART #	QTY.
1	Box, AC Super Electric Motor Starter	093021	1
2	Connector, GP29 Click 6180 0910	086576	3
3	Bolt, M8 x 30-8.8-B Hex Head	F81002-7	4
4	Nut, M8-8-B Hex	F81032-1	4
	Controller, ATV31HU11M2 220V/1.5kW Electric Motor Speed	093487	1
	Cord, 61746970 Rill 21	086557	1.15 m
	Cord, 61746980 Rill 29	086558	1.15 m
	Nut, 53019050 GMP-GL 21	086559	1
	Nut, 53019060 GMP-GL 29	086560	1
	Ring, 021 Sealing 5200 5750	086578	1
	Ring, 029 Sealing 5300 1040	086579	1
	Sleeve, Connector NW 6,3/1	F81079-4	4

4 Replacement Parts

Motor Assembly

4.4 Motor Assembly

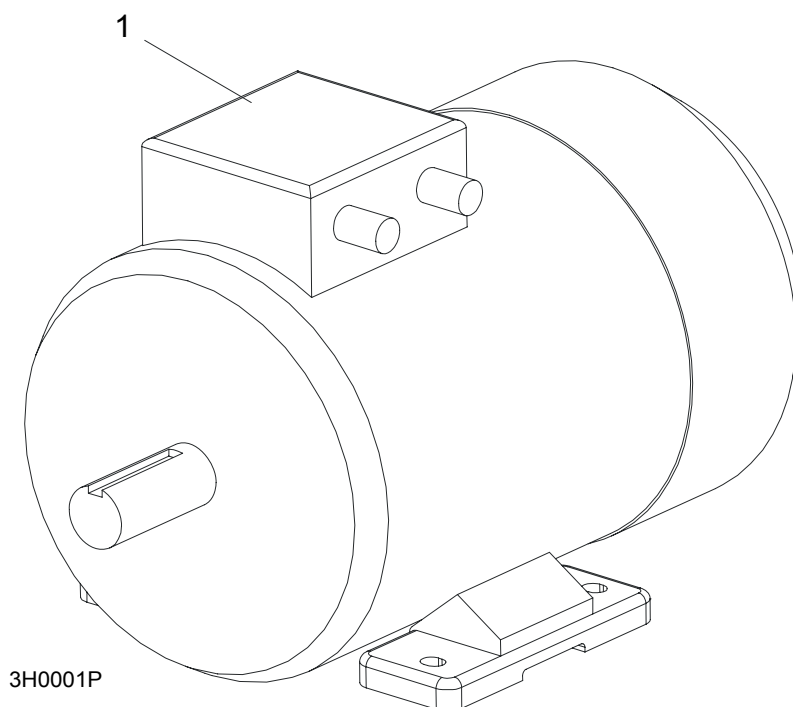

REF	DESCRIPTION (◆ Indicates Parts Available In Assemblies Only)	PART #	QTY.	
	MOTOR ASSEMBLY, AC 20HP (15KW) ELECTRIC	EA20	1	
1	MOTOR, 20HP (15KW) ELECTRIC EURO HPS	087396	1	
	MOUNT WELDMENT, E20/E25 ELECTRIC MOTOR	086801-1	1	
	PULLEY, EA20/EA25 ELECTRIC MOTOR	085671	1	
	BELT, 3BX74 DRIVE	014249	1	

4.5 Motor Pulley Guards, EA20.

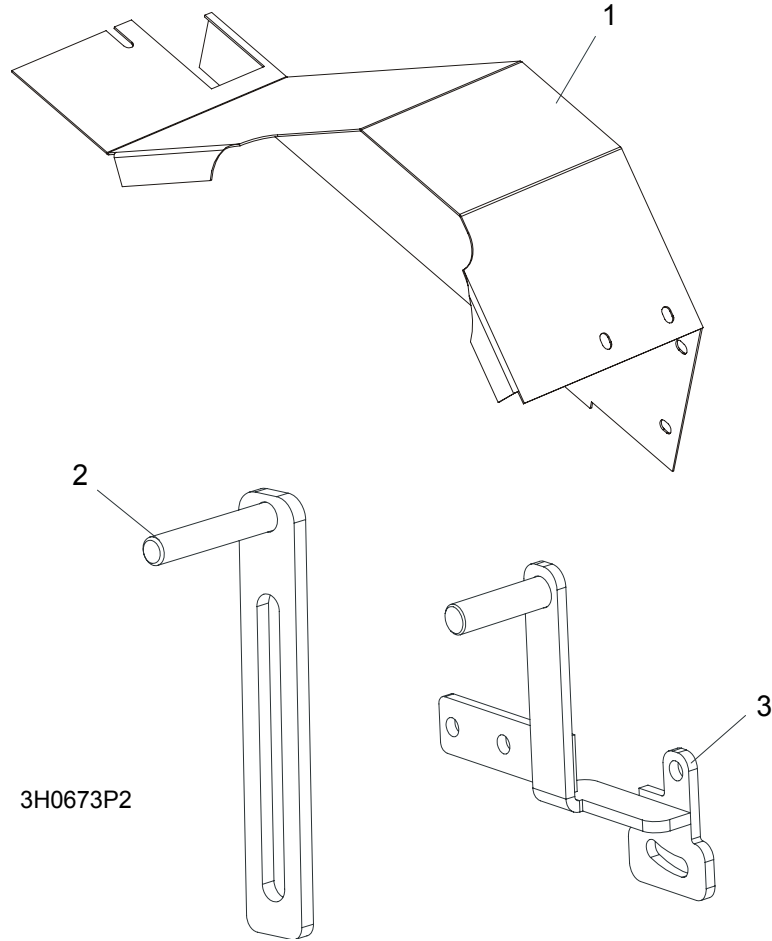

REF	DESCRIPTION (◆ Indicates Parts Available In Assemblies Only)	PART #	QTY.	
1	GUARD WELDMENT, EA20/EA25 MOTOR PULLEY	087059-1	1	
2	SUPPORT, DRIVE BELT UPPER	085865-1	1	
3	SUPPORT, DRIVE BELT LOWER	085922-1	1	



SECTION 5 ELECTRICAL INFORMATION

5.1 Electrical Symbol Diagram

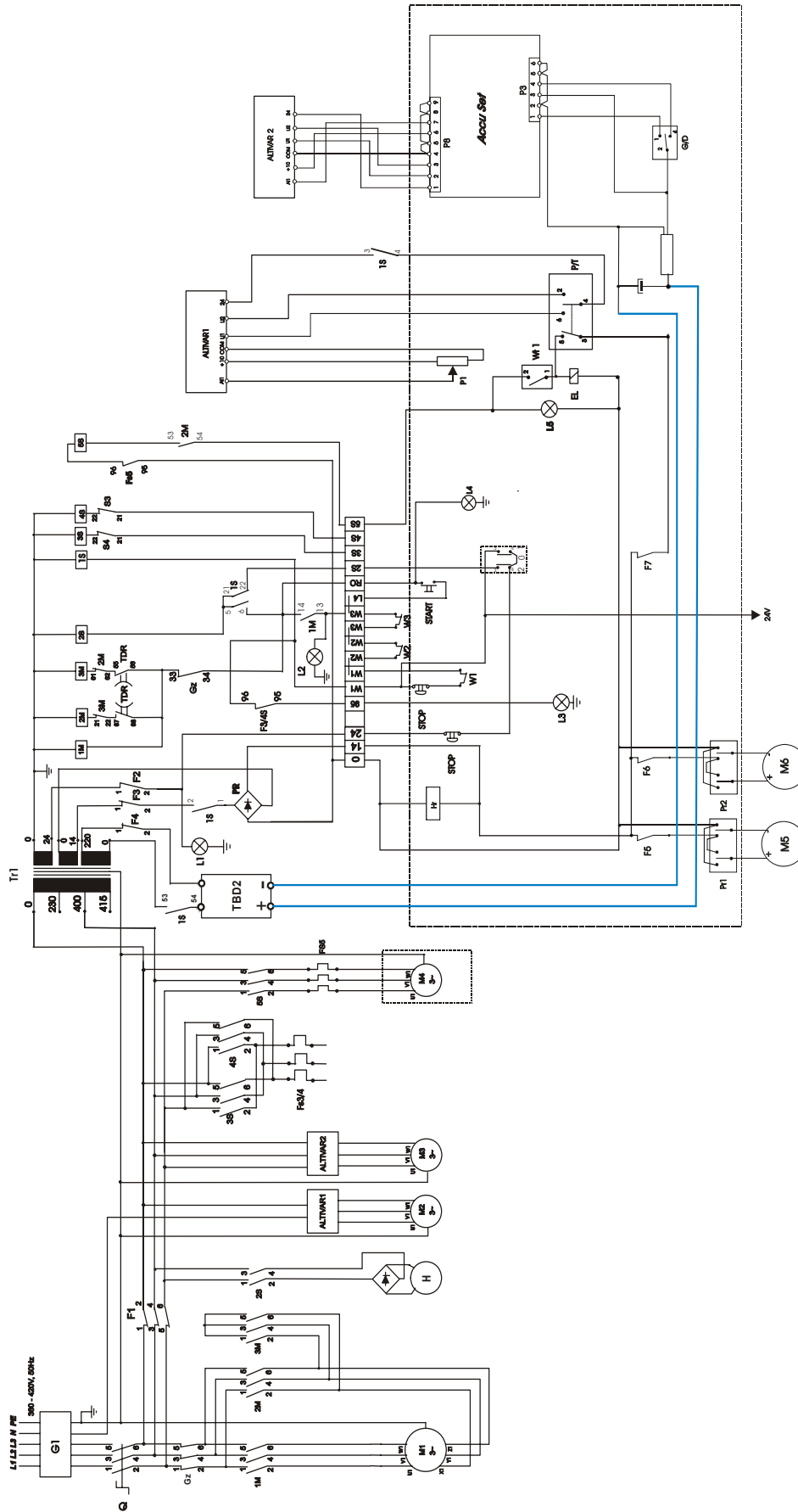

Caution!
 For Motor E15 Gz - 088264 (Gz1 M32)
 For Motor E20-25 Gz - 090436 (Gv3 ME40)

FIG. 5-1 SYMBOL DIAGRAM.

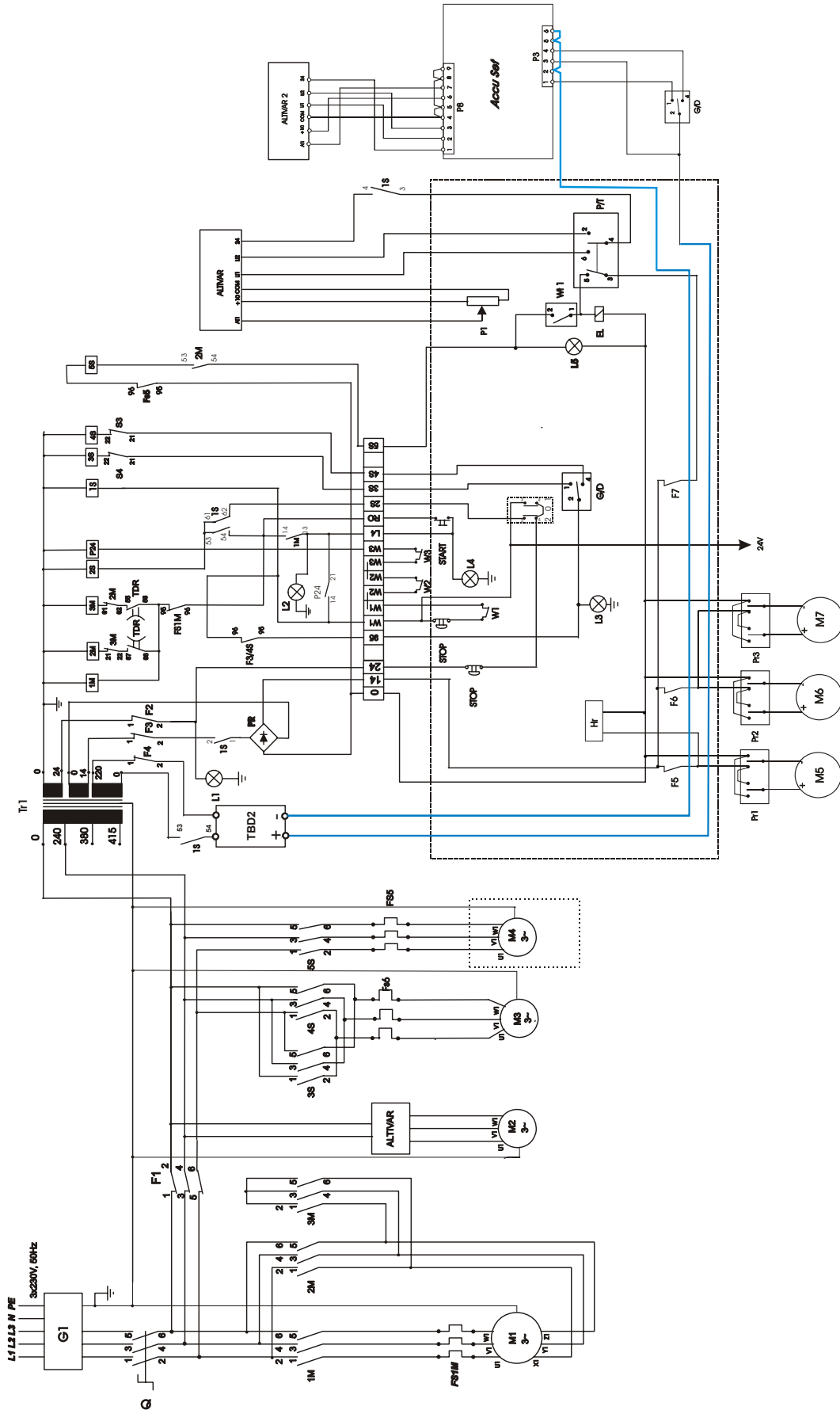

FIG. 5-2 SYMBOL DIAGRAM (NORWEGIAN VERSION).

Description (See Figure 5-1):

G1-	Socket 32A 380V
Q -	Main Switch
1M, 2M, 3M -	Soft Start Switch Contactor
Gz -	Blade Motor Safety Switch
2S -	Brake Contactor
3S, 4S -	Up/Down Switch Contactor
FS3/4 -	Up/Down Motor Thermal Relay
5S -	Debarker Contactor
FS5 -	Thermal Debarker Relay
F1 -	Autoswitch S193
M1-	Blade Motor
M2 -	Power Feed Motor
M3 -	Up/Down Motor
M4 -	Debarker Motor (Optional)
M5 -	Blade Cover Motor
M6 -	Board Return Motor
M7 -	Debarker Arm Motor
L1 -	White Lamp (Power On)
L2 -	Green Lamp (Ready To Operate)
L3 -	Lamp on the Control Box (Power On)
L4 -	Lamp on the Control Box (Ready To Operate)
Pr -	Bridge-Rectifire
W1 -	Loading Position Limit Switch
W2, W3 -	Blade Cover Limit Switch
F2, F3, F4 -	Autoswitch S193
Tr1 -	Transformer
WS1 -	Debarker Switch
Pr1-	Blade Cover Motor Switch
Pr2 -	Board Return Switch
Pr3 -	Debarker Arm Motor Switch
G/D -	Up/Down Switch
P/T -	Power Feed Switch
ALTIVAR -	Up/Down Motor Speed Controller
H -	Electric Motor Brake
PrH -	Electric Motor Bridge-Rectifire (inside the motor)

5.2 Main Electrical Box

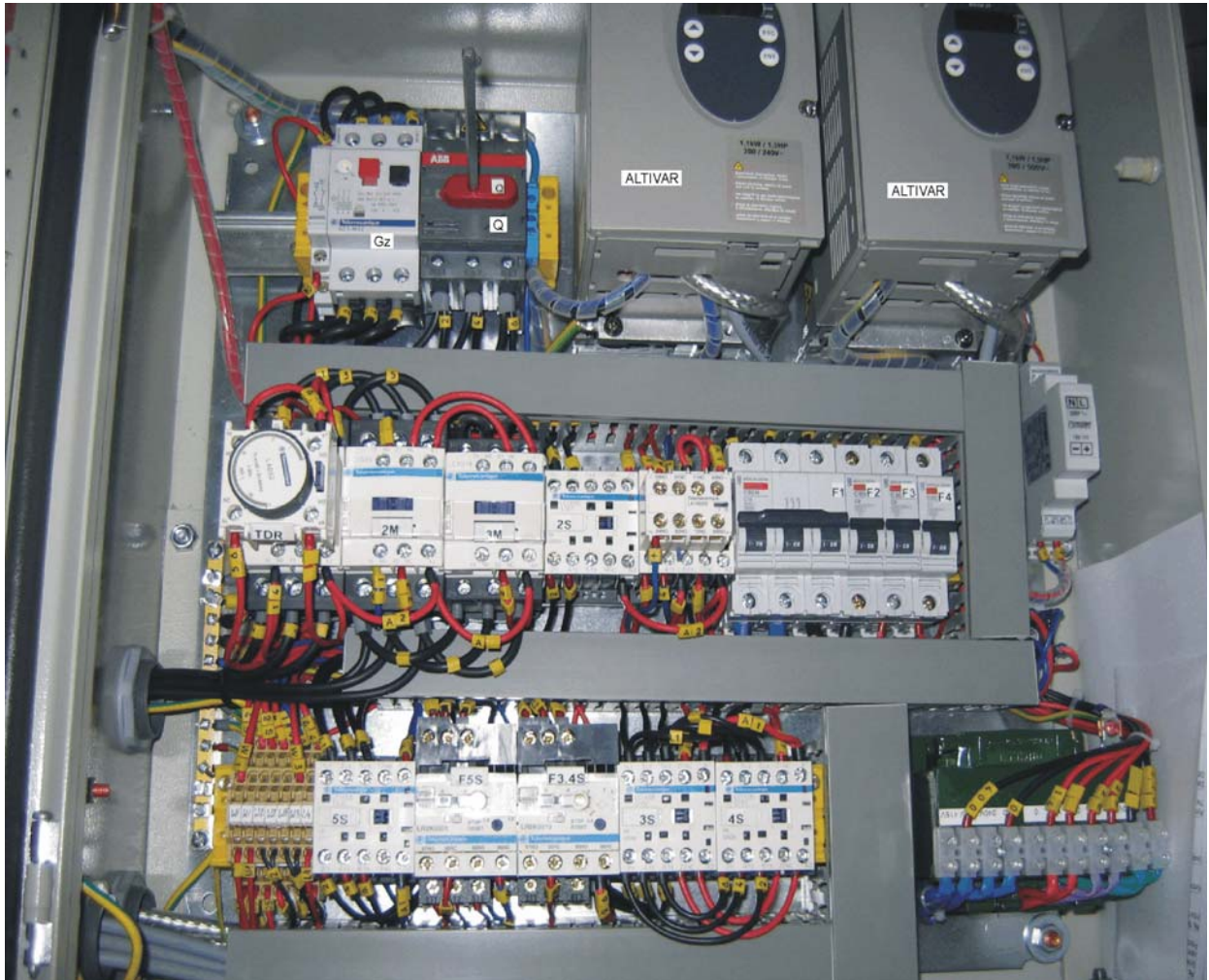

FIG. 5-3

5.3 Main Electrical Box Components

ID	Mfg. Part No.	Manufacturer	Wood-Mizer Part #	Description
Q	ABB OT45E3	ABB	095473	Switch
1M, 2M	LC1 D25B7	SCHNEIDER	090923	Contactora
3M	LC1 D18B7	SCHNEIDER	084306	Contactora
2S	LC1K0610B7	SCHNEIDER	084308	Contactora
5S	LP1K0610JD	SCHNEIDER	084323	Contactora
1S, 3S, 4S	LC1K0601B7	SCHNEIDER	084309	Contactora
F1	C60N C10 24349	SCHNEIDER	084317	Module Switch
F2	C60N C2 24396	SCHNEIDER	088278	Module Switch
F3	C60N C6 24399	SCHNEIDER	-	Module Switch
F4	C60N C1 24395	SCHNEIDER	084454	Module Switch
TR1	TMM160	BREVE	084315	Transformer
TDR	LADS2	SCHNEIDER	084037	Time Relay
PR	KPBC3508	-	084318	Bridge-Rectifier
L1	M22	MOELLER	090488	White Lamp
L2	M22	MOELLER	090488	Green Lamp
M2	STKg80X 4C2	BESEL	086530	Power Feed Motor
M3	STKg80X6/4L2	BESEL	086770	Up/Down Drive Motor
M5	STKg71X 2C	BESEL	086389	Debarker Motor
P1	1k	-	E20519	Potentiometer 1k
ATV	ATV31HU11M2	SCHNEIDER	093487	Motor Speed Controller
W1, W2	AZ17-11ZRK	SCHMERSAL	094232	Safety Switch
Fs3/4	LR2 K0310	SCHNEIDER	-	Thermal Relay
Fs5	LR2 K0308	SCHNEIDER	084312	Thermal Relay
-	TBD2/AS.0080.12E	COMATEC	097651	Impulse Feeder

TABLE 5-1

EA20 version

ID	Mfg. Part No.	Manufacturer	Wood-Mizer Part #	Description
M1	-	INDUKTA	with brake - 087396 without brake - 086856	Blade Drive Motor
GZ	GV3ME40	SCHNEIDER	090436	Switch, Motor On/Off

TABELA 5-2

5.4 HD Electrical Box Diagram (HD Sawmills Only)

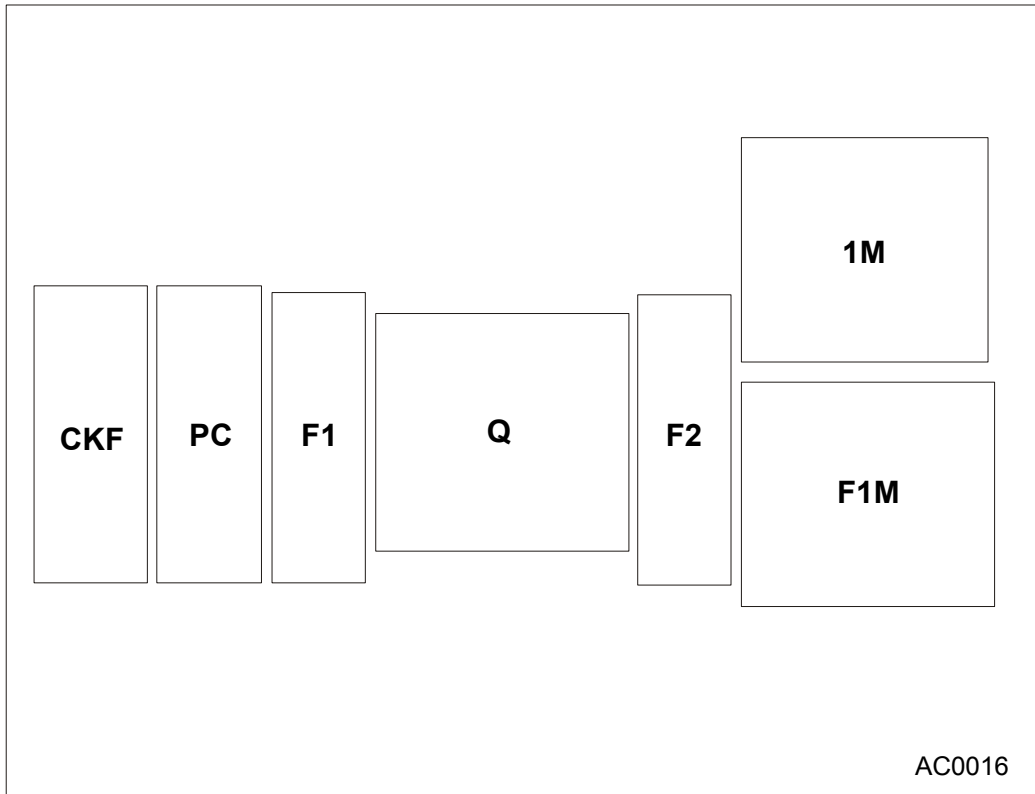

FIG. 5-4

5.5 HD Electrical Box Components (HD Sawmills Only)

ID	Mfg. Part No.	Manufacturer	Wood-Mizer Part #	Description
Q	ABB OT16E3	ABB	089801	Switch
1M	LC1 K09 B7	SCHNEIDER	084451	Contactator
F1	C60N C1 24395	SCHNEIDER	084454	Module Switch
F2	C60N C2 24396	SCHNEIDER	088278	Module Switch
M	SLg100L-4PC	INDUKTA	-	Hydraulic Feed Motor
CKF	RM4TG20	SCHNEIDER	084452	Phase Control Sensor
PC	RE9 RA11 MW7	SCHNEIDER	084453	Time Relay
F1M	LR2 K0316	SCHNEIDER	084456	Thermal Relay

TABLE 5-3

SECTION 6 BRAKE AIR GAP ADJUSTMENT

To ensure proper operation of the brake, it is necessary to set correctly the air gap between the armature and the electromagnet. Each time the brake is installed or the brake sub-assemblies are replaced or the motor overheats or the brake is inspected (**the inspection should be performed at least every six months**), check and, if necessary, adjust the brake air gap.

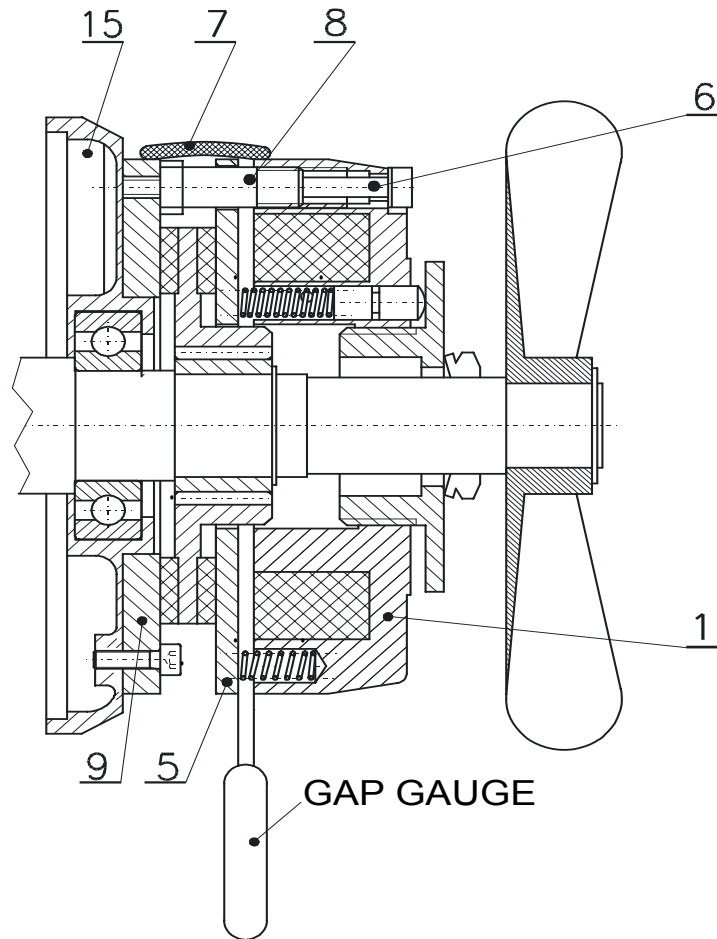

- 1 - body,
- 5 - armature,
- 6 - mounting bolt,
- 7 - brake casing,
- 8 - adjustment bolt,
- 9 - mounting disk,
- 15 - bearing shield.

Adjustment of the brake air gap is performed when the gap has reached the maximum value (see Table 1), and always after dismounting the brake and replacing or performing maintenance of damaged subassemblies.

6 Brake air gap adjustment

Table 1

Parameter	HPS 06	HPS 08	HPS 10	HPS 12	HPS 14	HPS 16	HPS 18	HPS 20	HPS 25
"a" nom.	0,20	0,20	0,20	0,30	0,30	0,30	0,30	0,30	0,40
"a" max.	0,50	0,50	0,50	0,70	0,80	1,00	1,20	1,20	1,40

To adjust the air gap, perform the following steps :

- Dismount the motor casing,
- Remove the brake casing (7),
- Loosen the mounting bolts (6) half a turn using an adequate allen wrench (see wrench sizes in Table 2),

Table 2

	HPS 06	HPS 08	HPS 10	HPS 12	HPS 14	HPS 16	HPS 18	HPS 20	HPS 25
Wrench size (mm)	3	4	5	5	6	6	6	8	8

- Screw the adjustment bolts (8) in the electromagnet body one turn using an adequate flat wrench (see wrench sizes in Table 3),

Table 3

	HPS 06	HPS 08	HPS 10	HPS 12	HPS 14	HPS 16	HPS 18	HPS 20	HPS 25
Wrench size (mm)	10	10	12	12	14	14	14	17	17

- Place the gap gauge (17) in the gap between the armature (5) and the electromagnet body (1). The thickness of the gauge should equal the nominal brake gap (see Table 1),

- Using the mounting bolts (6), press the body (1) to the armature so that the gap gauge can be removed at slight resistance and at the same resistance insert the gap gauge into gaps located every 120° from the place of the first measurement,

- Unscrew the adjustment bolts (8) so that they rest on the motor bearing shield or on the face of the brake mounting disk (9) (in brakes equipped with this element),

- Tighten the brake mounting bolts (6) and check the gap for correct adjustment with the gap gauge.