

# **EA15 Motor**

## **Safety, Operation, Maintenance & Parts Manual**

---

<b>LT40AC Series MH</b>	<b>rev. D5.03</b>
<b>LT40 Series AH</b>	<b>rev. D5.03</b>

---



**Safety is our #1 concern!** Read and understand all safety information and instructions before operating, setting up or maintaining this machine.

*November 1998*

*Form #970*

## Table of Contents

## Section-Page

<b>SECTION 1</b>	<b>SAFETY &amp; GENERAL INFORMATION</b>	<b>1-1</b>
1.1	Motor Operation .....	1-1
1.2	Electrical Operation.....	1-1
<b>SECTION 2</b>	<b>OPERATION</b>	<b>2-1</b>
2.1	Starting The Motor .....	2-1
<b>SECTION 3</b>	<b>MAINTENANCE</b>	<b>3-1</b>
3.1	Drive Belt Adjustment.....	3-1
<b>SECTION 4</b>	<b>REPLACEMENT PARTS</b>	<b>4-1</b>
4.1	How To Use The Parts List .....	4-1
4.2	Sample Assembly .....	4-1
4.3	Motor Starter Assembly .....	4-2
4.4	Motor Assembly .....	4-3
4.5	Motor Pulley Guards, EA15 .....	4-4
4.6	Power Cord Bracket .....	4-4
4.7	Power Cord Bracket, LT40B .....	4-5
<b>SECTION 5</b>	<b>BRAKE AIR GAP ADJUSTMENT</b>	<b>5-1</b>

## SECTION 1 SAFETY & GENERAL INFORMATION



**IMPORTANT!** This manual is provided as a supplement to the equipment manufacturer's manuals. This manual takes into account the specific use of engines on the Wood-Mizer sawmill. Only safety, maintenance, and operating procedures that are not provided by the manufacturer are supplied in this manual. Refer to the manufacturer's manual before attempting to operate this equipment.



This symbol calls your attention to instructions concerning your personal safety. Be sure to observe and follow these instructions. This symbol accompanies a signal word. The word **DANGER** indicates an imminently hazardous situation which, if not avoided, will result in death or serious injury. **WARNING** suggests a potentially hazardous situation which, if not avoided, could result in death or serious injury. **CAUTION** refers to potentially hazardous situations which, if not avoided, may result in minor or moderate injury to persons or equipment. Read all safety instructions before operating this equipment and observe all safety warnings!

### 1.1 Motor Operation



**DANGER!** Always be sure the blade is disengaged and all persons are out of the path of the blade before starting the engine or motor. Failure to do so will result in serious injury.



**WARNING!** Do not for any reason adjust the motor drive belts or belt support bracket with the motor running. Doing so may result in serious injury.

**WARNING!** Remove the blade before performing any motor service. Failure to do so may result in serious injury.



**WARNING!** Be sure the power feed switch is in the neutral position before turning the key switch to the (#1) or (#2) position. This prevents accidental carriage movement, which may cause serious injury or death.

### 1.2 Electrical Operation



**DANGER!** Make sure all electrical installation, service and/or maintenance work is performed by a qualified electrician and is in accordance with applicable electrical codes.

**DANGER!** Hazardous voltage inside the disconnect box, starter box, and at the electric motor can cause shock, burns, or death. Disconnect and lock out power supply before servicing! Keep all electrical component covers closed and securely fastened during mill operation.



## SECTION 2 OPERATION

### 2.1 Starting The Motor

#### Control Box

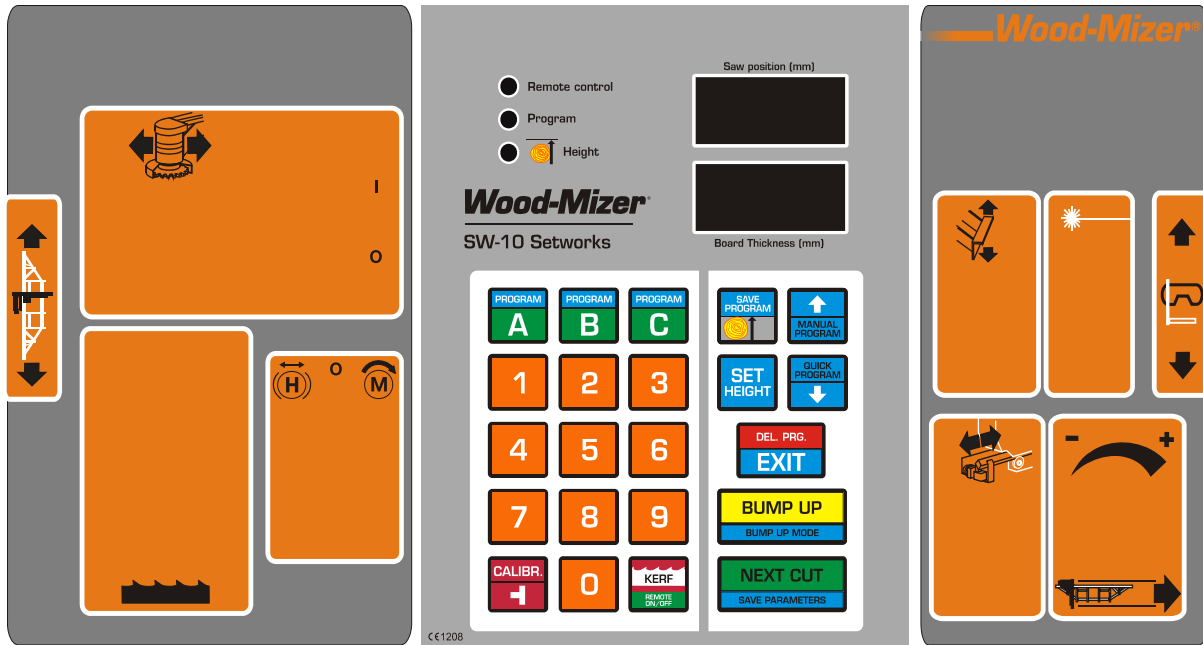

RYS. 2-0

### Motor Start



**IMPORTANT!** When starting the machine for the first time, check that main motor rotation direction is as indicated by the arrow located on the motor body (fan guard). If the rotation direction is incorrect, invert the phases in the phase inverter located in the power socket (electric box). Setting the phases in the phase inverter correctly will ensure correct rotation directions of all sawmill motors.



**DANGER!** Always be sure the blade is disengaged and all persons are out of the path of the blade before starting the engine or motor. Failure to do so will result in serious injury.



**WARNING!** Be sure the power feed switch is in the neutral position before turning the key switch to the (#1) or (#2) position. This prevents accidental carriage movement which may cause serious injury or death.

Turn the key switch to the start (#1) position and press the “START” button on the control panel.

### Motor Shutoff

Turn the key switch to the off (#0) position and press the “STOP” button on the control panel.

## SECTION 3 MAINTENANCE

 **This symbol** identifies the interval (hours of operation) which each maintenance procedure should be performed. "AR" signifies maintenance procedures which should be performed as required.

### 3.1 Drive Belt Adjustment

 Periodically check all belts for wear. Replace any damaged or worn belts as needed.

 **DANGER!** Do not for any reason adjust the drive belt support with the motor running. Always stop the motor before reaching or looking into the drive belt area.

## SECTION 4 REPLACEMENT PARTS

### 4.1 How To Use The Parts List

- Use the table of contents or the index to locate the assembly that contains the part you need.
- Go to the appropriate section and locate the part in the illustration.
- Use the number pointing to the part to locate the correct part number and description in the table.
- Parts shown indented under another part are included with that part.
- Parts marked with a diamond (◆) are only available in the assembly listed above the part.

See the sample table below. Sample Part #A01111 includes part F02222-2 and subassembly A03333. Subassembly A03333 includes part S04444-4 and subassembly K05555. The diamond (◆) indicates that S04444-4 is not available except in subassembly A03333. Subassembly K05555 includes parts M06666 and F07777-77. The diamond (◆) indicates M06666 is not available except in subassembly K05555.

4.2 Sample Assembly				
REF	DESCRIPTION (◆ Indicates Parts Available In Assemblies Only)	PART #	QTY.	
	<b>SAMPLE ASSEMBLY, COMPLETE (INCLUDES ALL INDENTED PARTS BELOW)</b>	A01111	1	
1	Sample Part	F02222-22	1	
	Sample Subassembly (Includes All Indented Parts Below)	A03333	1	
2	Sample Part (◆ Indicates Part Is Only Available With A03333)	S04444-4	1	◆
	Sample Subassembly (Includes All Indented Parts Below)	K05555	1	
3	Sample Part (◆ Indicates Part Is Only Available With K05555)	M06666	2	◆
4	Sample Part	F07777-77	1	

#### To Order Parts:

- From Europe call our European Headquarters and Manufacturing Facility in Kolo, Poland at **+48-63-2626000** or **+48-3912-1319**. From the continental U.S., call **1-800-448-7881** to order parts. Have your customer number, vehicle identification number, and part numbers ready when you call.
- From other international locations, contact the Wood-Mizer distributor in your area for parts.



### 4.3 Motor Starter Assembly

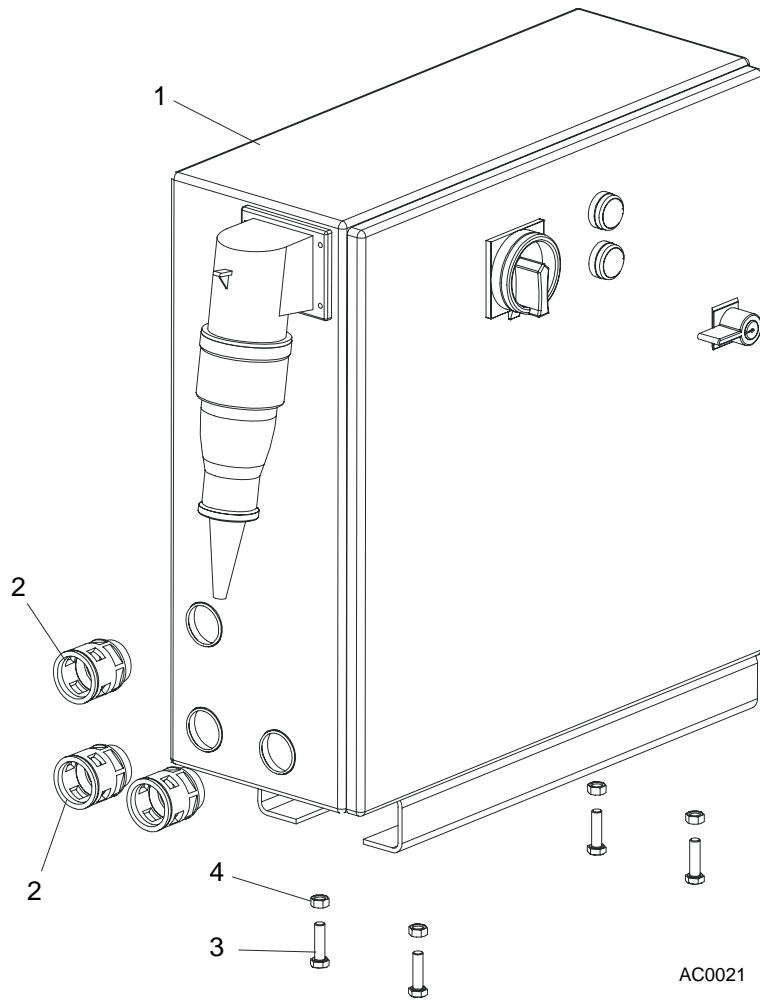

REF	DESCRIPTION (◆ Indicates Parts Available In Assemblies Only)	PART #	QTY.
1	Box, AC Super Electric Motor Starter	098736	1
2	Connector, GP29 Click 6180 0910	086576	3
3	Bolt, M8 x 30-8.8-B Hex Head	F81002-7	4
4	Nut, M8-8-B Hex	F81032-1	4
	Controller, ATV31HU11M2 220V/1.5kW Electric Motor Speed	093487	1
	Cord, 61746970 Rill 21	086557	1.15 m
	Cord, 61746980 Rill 29	086558	1.15 m
	Nut, 53019050 GMP-GL 21	086559	1
	Nut, 53019060 GMP-GL 29	086560	1
	Ring, 021 Sealing 5200 5750	086578	1
	Ring, 029 Sealing 5300 1040	086579	1
	Sleeve, Connector NW 6,3/1	F81079-4	4

**4.4 Motor Assembly**

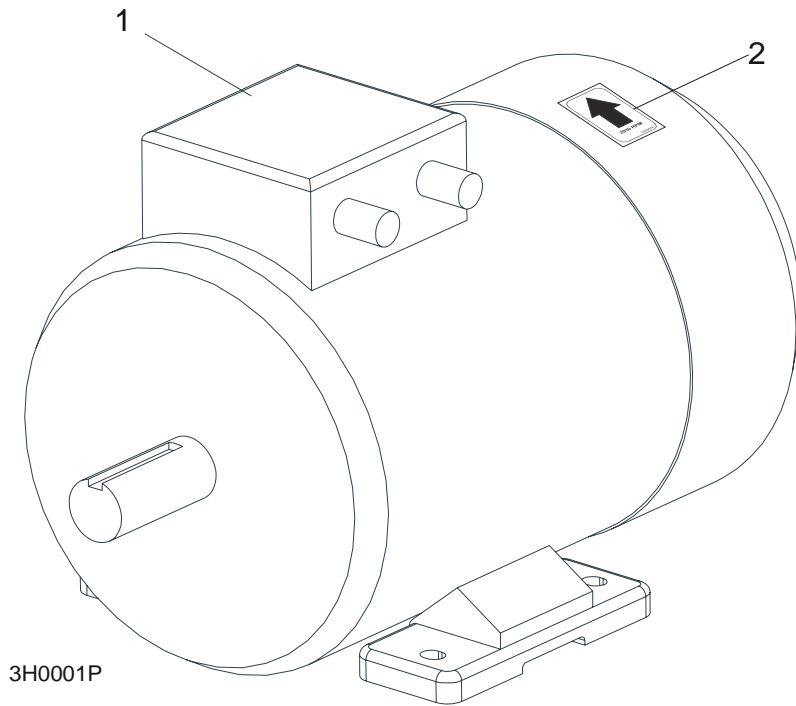

REF	DESCRIPTION (◆ Indicates Parts Available In Assemblies Only)	PART #	QTY.	
	<b>MOTOR, E15HP COMPLETE</b>	EA15	1	
<b>1</b>	MOTOR, 11KW SG132S-2PC WITH BRAKE HPS16	087391	1	
	MOTOR, 11KW 230 VOLT (NORWEGIAN VERSION ONLY)	087391-2	1	
	PLATE, MOUNT ELECTRIC MOTOR PTD	W85055-1	1	
	MOTOR PULLEY, 3-GROOVE	087526	1	
	Bushing, E15 Motor	087066	1	
	BELT, 2BX70 DRIVE	P04857-2	1	
<b>2</b>	<b>DECAL, ROTATION DIRECTION - 2930 RPM</b>	S20097E <sup>1</sup>	1	

<sup>1</sup> Belongs to LT40AC Pictographic Decal Kit - Part No. 099516.

## 4.5 Motor Pulley Guards, EA15

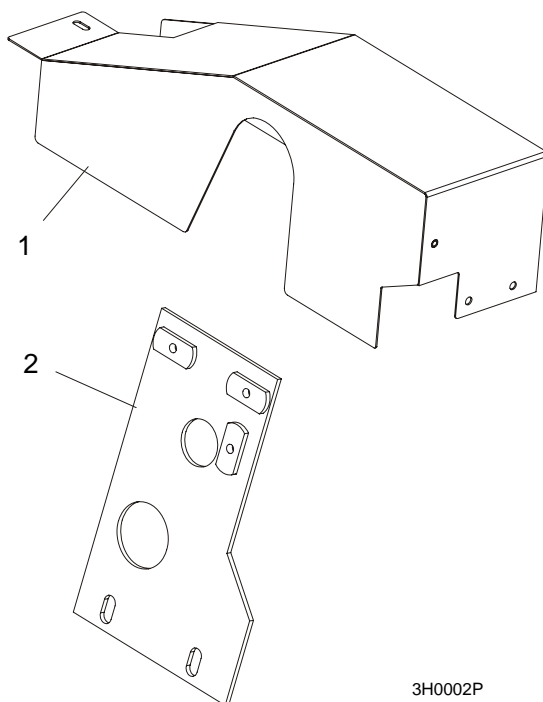

REF	DESCRIPTION (◆ Indicates Parts Available In Assemblies Only)	PART #	QTY.	
1	COVER BELT UPPER,ENGINE 15HP ELECTRIC PT	085721-1	1	
2	BRACKET, E15 MOTOR PULLEY GUARD, PTD	087172-1	1	
	IDLER BELT, SPIDER PTD (EA15 ONLY)	086231-1	1	

## 4.6 Power Cord Bracket

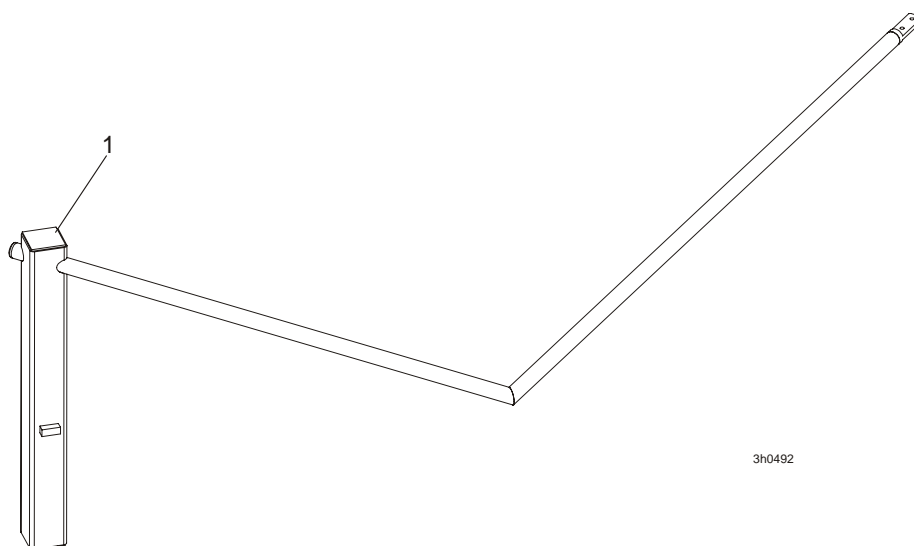

REF	DESCRIPTION (◆ Indicates Parts Available In Assemblies Only)	PART #	QTY.	
1	BRACKET, POWER CORD PTD	091813-1	1	

4.7 Power Cord Bracket, LT40B

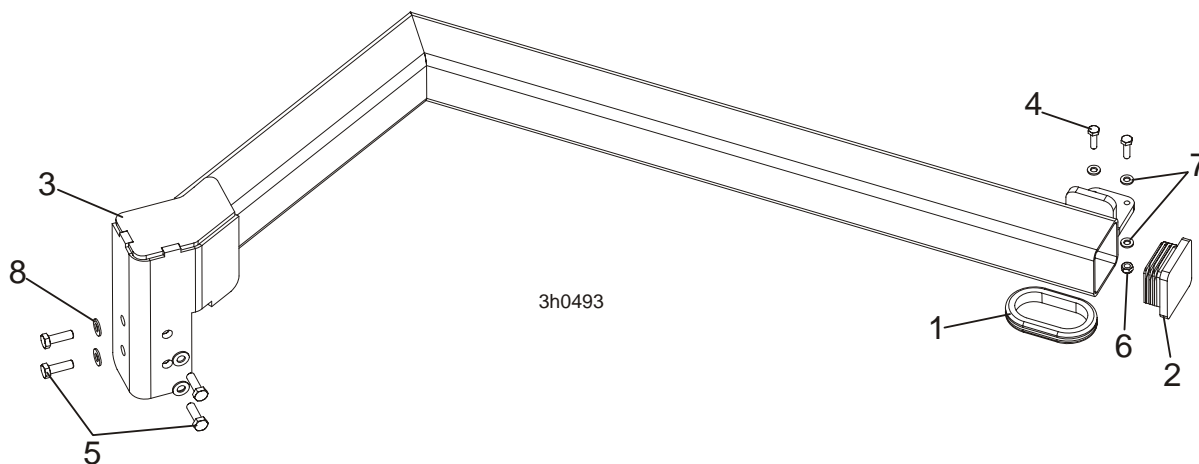

REF	DESCRIPTION (◆ Indicates Parts Available In Assemblies Only)	PART #	QTY.
	<b>BRACKET, LT40B POWER CORD COMPLETE</b>	504309	1
1	GROMMET, RUBBER	087065	1
2	CAP, SR 1540 199211 OUTRIGGER LEG	089710	1
3	BRACKET, LT40B POWER CORD	504307-1	1
4	BOLT, M6X20-8.8 HEX HEAD FULL THREAD ZINC	F81001-2	2
5	BOLT, M8X25-8.8-B HEX HEAD FULL THREAD ZINC	F81002-5	4
6	NUT, M6-8-B HEX,NYLON LOCK ZINC	F81031-2	2
7	WASHER, 6.4 FLAT ZINC	F81053-1	4
8	WASHER, 8.4 FLAT ZINC	F81054-1	4

## SECTION 5 BRAKE AIR GAP ADJUSTMENT

To ensure proper operation of the brake, it is necessary to set correctly the air gap between the armature and the electromagnet. Each time the brake is installed or the brake subassemblies are replaced or the motor overheats or the brake is inspected (**the inspection should be performed at least every six months**), check and, if necessary, adjust the brake air gap.

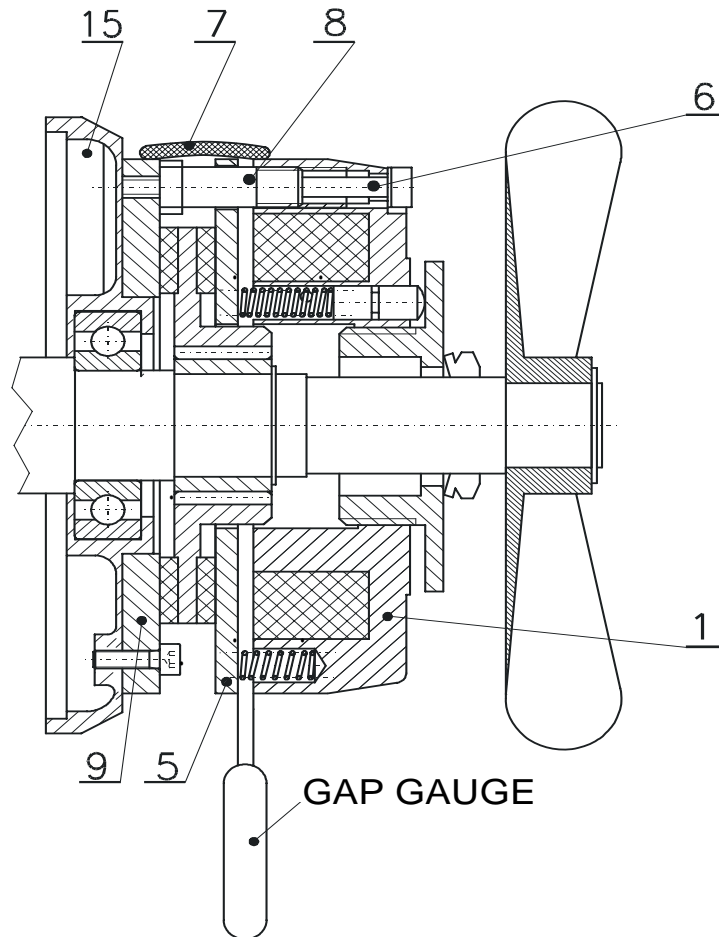

- 1 - body,
- 5 - armature,
- 6 - mounting bolt,
- 7 - brake casing,
- 8 - adjustment bolt,
- 9 - mounting disk,
- 15 - bearing shield.

Adjustment of the brake air gap is performed when the gap has reached the maximum value (see Table 1), and always after dismantling the brake and replacing or performing maintenance of damaged sub-assemblies.

Table 1

Parameter	HPS 06	HPS 08	HPS 10	HPS 12	HPS 14	HPS 16	HPS 18	HPS 20	HPS 25

"a" nom.	0,20	0,20	0,20	0,30	0,30	0,30	0,30	0,30	0,40
"a" max.	0,50	0,50	0,50	0,70	0,80	1,00	1,20	1,20	1,40

To adjust the air gap, perform the following steps :

- Dismount the motor casing,
- Remove the brake casing (7),
- Loosen the mounting bolts (6) half a turn using an adequate allen wrench (see wrench sizes in Table 2),

Table 2

	HPS 06	HPS 08	HPS 10	HPS 12	HPS 14	HPS 16	HPS 18	HPS 20	HPS 25
Wrench size (mm)	3	4	5	5	6	6	6	8	8

- Screw the adjustment bolts (8) in the electromagnet body one turn using an adequate flat wrench (see wrench sizes in Table 3),

Table 3

	HPS 06	HPS 08	HPS 10	HPS 12	HPS 14	HPS 16	HPS 18	HPS 20	HPS 25
Wrench size (mm)	10	10	12	12	14	14	14	17	17

- Place the gap gauge (17) in the gap between the armature (5) and the electromagnet body (1). The thickness of the gauge should equal the nominal brake gap (see Table 1),

- Using the mounting bolts (6), press the body (1) to the armature so that the gap gauge can be removed at slight resistance and at the same resistance insert the gap gauge into gaps located every 120° from the place of the first measurement,

- Unscrew the adjustment bolts (8) so that they rest on the motor bearing shield or on the face of the brake mounting disk (9) (in brakes equipped with this element),

- Tighten the brake mounting bolts (6) and check the gap for correct adjustment with the gap gauge.