

Wood-Mizer[®] Sawmill

Parts Manual

LT40L DH

rev. D1.00



Safety is our #1 concern! Read and understand all safety information and instructions before operating, setting up or maintaining this machine.

May 2002

Form #948

Table of Contents

Section-Page

SECTION 1	GENERAL INFORMATION	1-1
1.1	How To Use The Parts List	1-1
1.2	Sample Assembly	1-1
SECTION 2	BLADE GUIDE ROLLERS & ARM	2-1
2.1	Blade Guide Assembly, Idle Side (Standard).....	2-1
2.2	Blade Guide Assembly, Idle Side (Optional).....	2-2
2.3	Blade Guide Assembly, Drive Side (Optional).....	2-4
2.4	Idle Side Blade Guide Assembly, Optional (LMS).....	2-6
2.5	Blade Guide Assembly, Drive Side.....	2-8
2.6	Blade Guide Arm & Rollers	2-10
2.7	Blade Guide Arm Drive Assembly.....	2-11
SECTION 3	BLADE WHEELS & TENSIONER	3-1
3.1	Blade Drive Assembly.....	3-1
3.2	Idle Blade Wheel Assembly	3-3
3.3	Hydraulic Blade Tensioner Assembly.....	3-4
SECTION 4	SAW HEAD	4-1
4.1	Middle Throat Screw	4-1
4.2	Water Lube Solenoid Valve	4-1
4.3	Clutch Lever Assembly	4-2
4.4	Brake Assembly.....	4-4
4.5	Board Return Assembly	4-5
4.6	Water Lube Assembly	4-7
4.7	LT40DC Saw Head Decals	4-9
4.8	Blade Housing Covers	4-10
4.9	Drive Belt Covers	4-12
4.10	Sawdust Chute	4-13
SECTION 5	CONTROL & BATTERY BOXES	5-1
5.1	Control Assembly, LT40 Series	5-1
5.2	Drum Switches	5-3
5.3	Circuit Breakers	5-4
5.4	Solenoid Assemblies	5-5
5.5	Battery Box Assembly, LT40 Series	5-6
5.6	Fuse Box Assembly, LT40 Series	5-7
SECTION 6	UP/DOWN SYSTEM	6-1
6.1	Saw Head V-Brace Mount	6-1
6.2	Blade Height Scale	6-2
6.3	Up/Down Chain & Sprockets.....	6-4
6.4	Up/Down Motor Assembly, LT40 Series	6-6
6.5	Up/Down Drive Assembly, LT40 Series	6-7

Table of Contents

Section-Page

SECTION 7	POWER FEED & TRACK ROLLERS	7-1
7.1	Upper Track Rollers And Wipers.....	7-1
7.2	Power Feed Assembly,	7-2
7.3	Feed Chain/Stop, LT40 Series	7-4
7.4	Lower Track Rollers	7-6
SECTION 8	BED FRAME ASSEMBLY	8-1
8.1	Bed Rail Assembly, Rear	8-1
8.2	Bed Rail Assembly, Front Middle	8-2
8.3	Bed Rail Assembly, Rear Middle	8-3
8.4	Clamp Mount Assembly, Front (A/DH5/7).....	8-4
8.5	Clamp Mount Assembly, Rear (A/DH5/7).....	8-5
8.6	Leg, Stationary	8-6
8.7	Pivot Bed Rail Assembly.....	8-8
8.8	Log Side Support Assembly (Manual)	8-9
8.9	LT70 S/M Saw Head Rest Pin Assembly.....	8-10
8.10	Bed Frame Decals	8-11
8.11	Tie Down Chain Assembly	8-12
SECTION 9	HYDRAULIC SYSTEM	9-1
9.1	Hydraulic Hoses	9-1
9.2	Hydraulic Control Box, LT70 Series DH3.....	9-3
9.3	Hydraulic Control Box, LT70 Series DH5/7.....	9-5
9.4	Hydraulic Power Supply Strip.....	9-7
9.5	Hydraulic Log Loader	9-9
9.6	Hydraulic Log Turner	9-10
9.7	Hydraulic Log Side Supports (S/M Type Frame)	9-12
9.8	Hydraulic Pull Down Clamp	9-13
9.9	Hydraulic Log Clamp - main.....	9-15
9.10	Hydraulic Toe Board	9-17

SECTION 1 GENERAL INFORMATION

1.1 How To Use The Parts List

- Use the index above to locate the assembly that contains the part you need.
- Go to the appropriate section and locate the part in the illustration.
- Use the number pointing to the part to locate the correct part number and description in the table.
- Parts shown indented under another part are included with that part.
- Parts marked with a diamond (◆) are only available in the assembly listed above the part.

See the sample table below. Sample Part #A01111 includes part F02222-2 and subassembly A03333. Subassembly A03333 includes part S04444-4 and subassembly K05555. The diamond (◆) indicates that S04444-4 is not available except in subassembly A03333. Subassembly K05555 includes parts M06666 and F07777-77. The diamond (◆) indicates M06666 is not available except in subassembly K05555.

1.2 Sample Assembly				
REF	DESCRIPTION (◆ Indicates Parts Available In Assemblies Only)	PART #	QTY.	
	Sample Assembly, Complete (Includes All Indented Parts Below)	A01111	1	
1	Sample Part	F02222-22	1	
	Sample Subassembly (Includes All Indented Parts Below)	A03333	1	
2	Sample Part (◆ Indicates Part Is Only Available With A03333)	S04444-4	1	◆
	Sample Subassembly (Includes All Indented Parts Below)	K05555	1	
3	Sample Part (◆ Indicates Part Is Only Available With K05555)	M06666	2	◆
4	Sample Part	F07777-77	1	

To Order Parts:

- From Europe call our European Headquarters and Manufacturing Facility in Kolo, Poland at **+48-63-2626000**. From the continental U.S., call our toll-free Parts hotline at **1-800-448-7881**. Have your customer number, vehicle identification number, and part numbers ready when you call.
- From other international locations, contact the Wood-Mizer distributor in your area for parts.

SECTION 2 BLADE GUIDE ROLLERS & ARM

2.1 Blade Guide Assembly, Idle Side (Standard)

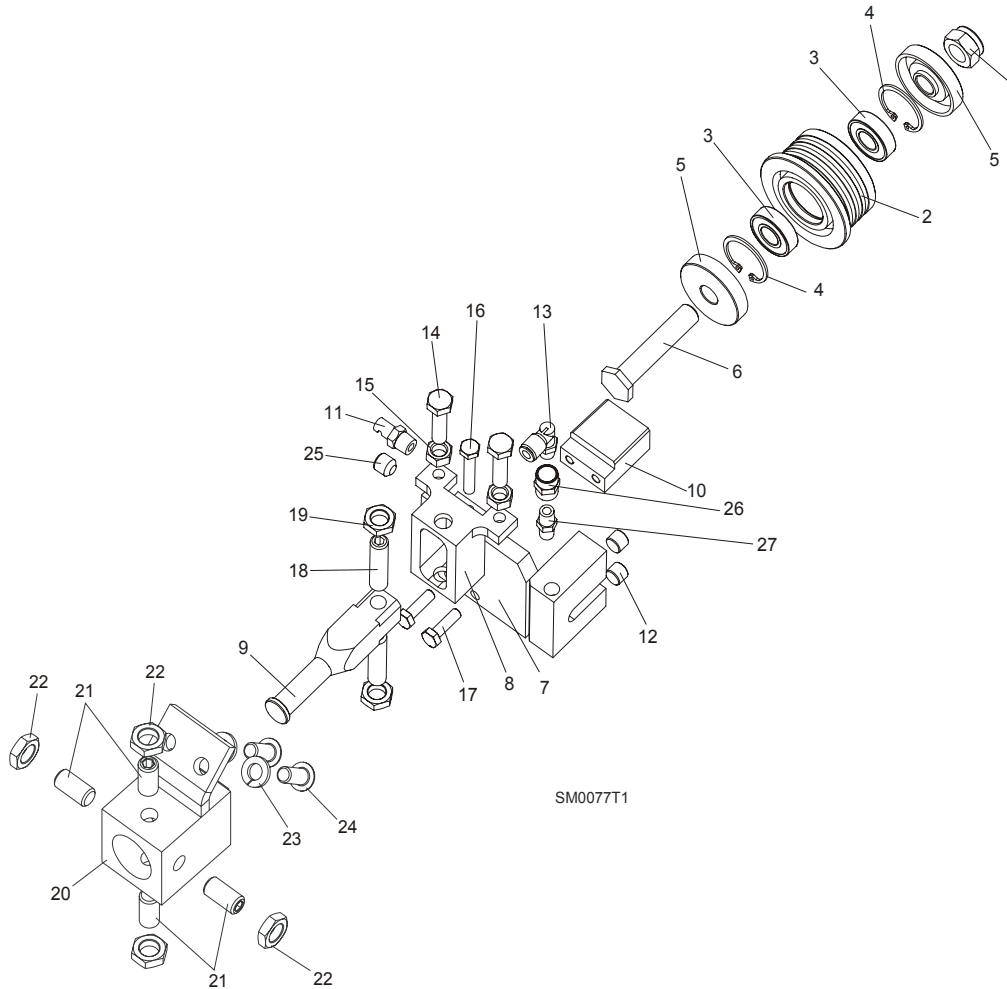

REF	DESCRIPTION (◆ Indicates Parts Available In Assemblies Only)	PART#	QTY.
	BLADE GUIDE ASSEMBLY, IDLE SIDE	092523	1
	BLADE GUIDE ASSEMBLY, IDLE SIDE, EXTENDED (for optional use with 1 1/2" blades)	092994	1
	Roller, Blade Guide Narrow W/Bearings	088261	1
	Roller, Blade Guide W/Bearings Extended (for optional use with 1 1/2" blades)	092939	1
1	Nut, M12-8 Hex Nylon Zinc Lock	F81034-2	1
2	Roller, Blade Guide Narrow	087889	1
	Roller, Blade Guide Extended (for optional use with 1 1/2" blades)	087890	1
3	Bearing, 6001 2RSR NACHI	087893	2
4	Ring, W28 Inside Retaining	F81090-9	2
5	Washer, Spacer	087891-1	2 (1)
	Washer, Spacer (used with the Extended Roller only) ¹	087892-1	1
6	Bolt, Blade Guide Roller Zinc Plated	087761-1	1
	Bolt, Blade Guide Roller Zinc Plated (used with the Extended Roller only)	092940-1	1
7	Block Weldment, Nozzle Zinc Plated	087750-1	1
8	Block, Zinc Plated Roller Guide Adjuster	087756-1	1

2 Blade Guide Rollers & Arm

Blade Guide Assembly, Idle Side (Optional)

9	Shaft, Zinc Plated Blade Guide Mount	088255-1	1	
10	Block, Blade Guide Zinc	096956-1	1	
11	Nozzle, Blade Water Lube Spray	016637	1	
12	Plug, M10x1 DIN 906 BN40 "BOSSARD"	F81015-3	2	
13	Fitting, 90° Elbow 1/8NPT-1/4 Tube Swivel	P09736	1	
14	Bolt, M8x30 DIN933 A2-70 Stainless Steel	F81002-27	2	
15	Nut, M8 DIN934 A2-70 Stainless Steel	F81032-7	2	
16	Bolt, M6x30 DIN933 A2-70 Stainless Steel	F81001-37	1	
17	Bolt, M6x20-8.8 Hex Head Full Thread Zinc	F81001-2	2	
18	Screw, M10x1x40 DIN913 Stainless Steel Set	F81015-2	2	
19	Nut, M10x1-04-ST-A2 ISO 8675 Thin	F81033-10	2	
20	BLOCK WELDMENT, PAINTED BLADE GUIDE MOUNT	088292-1	1	
21	SCREW, M10X1X20 DIN913 STAINLESS STEEL SET	F81015-1	4	
22	NUT, M10x1-04-ST-A2 ISO 8675 THIN	F81033-10	4	
23	WASHER, 8.2 SPLIT LOCK ZINC	F81054-4	2	
24	BOLT, 5/16-18X3/4 SOCKET HEAD	F05006-102	2	
25	FITTING, 1/8 NPT SOCKET PIPE PLUG	P30127	1	
26	FITTING, 1/8FPT COUPLING	P05748	1	
27	NIPPLE, 1/8 DRY SEAL	P02764	1	

¹ Used only from the flanged side of the roller

2.2 Blade Guide Assembly, Idle Side (Optional)

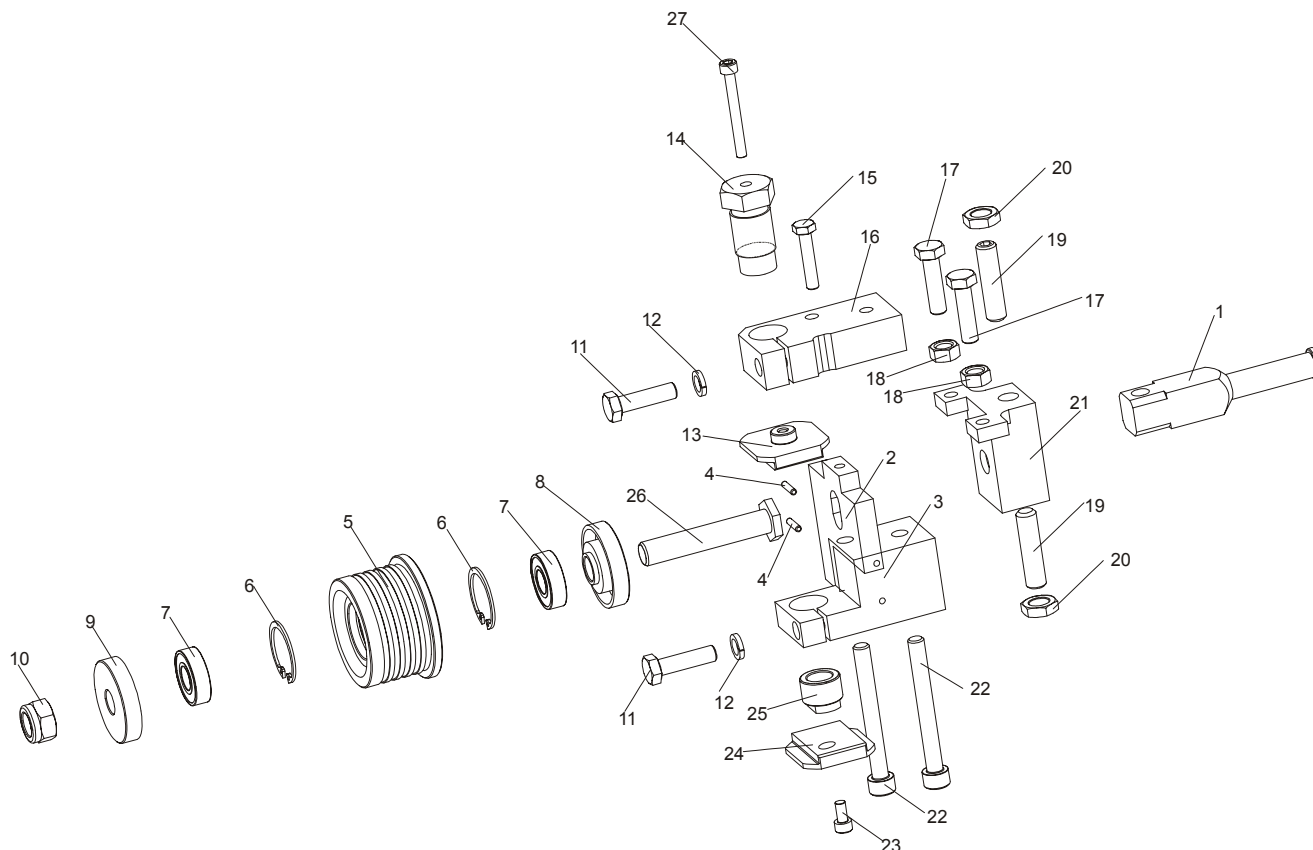

REF	DESCRIPTION (◆ Indicates Parts Available In Assemblies Only)	PART#	QTY.	
	BLADE GUIDE ASSEMBLY, IDLE SIDE, EXTENDED (for optional use with 1 1/2" blades)	093760	1	
1	SHAFT, BLADE GUIDE MOUNT	088255	1	

	MOUNTING PLATE ASSEMBLY	093763	1	
2	PLATE, BLADE GUIDE MOUNTING	093761	1	
3	BLOCK, LOWER PAD MOUNT	093769	1	
4	PIN, 3m6x14 DIN 6325 HRC 60 ROLL	F81048-6	2	
	ROLLER, BLADE GUIDE EXTENDED W/BEARINGS	092939	1	
5	ROLLER, BLADE GUIDE EXTENDED	087890	1	
28	RING, W28 INSIDE RETAINING	F81090-9	2	
7	BEARING, 6001 2RSR (FAG,SKF)	087893	2	
8	RING, SPACER	087892	1	
9	RING, SPACER	089891	1	
10	NUT, M12-8 HEX NYLON ZINC LOCK	F81034-2	1	
11	BOLT, M8x30 DIN933 A2-70 STAINLESS STEEL	F81002-27	2	
12	WASHER, 8.2 SPLIT LOCK ZINC	F81054-4	2	
13	BLOCK, BLADE GUIDE ZINC-PLATED	093430-1	1	
14	BOLT, UPPER BLOCK ADJUSTMENT	089515	1	
15	BOLT, M6x30 DIN933 A2-70 STAINLESS STEEL	F81001-37	1	
16	BLOCK, UPPER PAD MOUNT	093762	1	
17	BOLT, M8x30 DIN933 A2-70. STAINLESS STEEL	F81002-27	2	
18	NUT, M8 DIN 934 A2-70 STAINLESS STEEL	F81032-7	2	
19	SCREW, M10x1x40 Din913 SET STAINLESS STEEL	F81015-2	2	
20	NUT, PN-EN ISO 8675-M10X1-04-St-A2 HEX THIN FINE THREAD	F81033-10	2	
21	BLOCK, BLADE DEFLECTION ADJUSTMENT	087756	1	
22	SCREW, M8x40-8.8 HEX SOCKET HEAD CAP ZINC	F81002-29	2	
23	SCREW, M5X10 DIN 912 A2-70 HEX SOCKET HEAD CAP STAINLESS STEEL	F81000-23	1	
24	BLOCK, BLADE GUIDE ZINC-PLATED	093430-1	1	
25	SCREW, LOWER PAD ADJUSTMENT	090945	1	
26	BOLT, EXT. BLADE GUIDE ROLLER LONG	092940	1	

2.3 Blade Guide Assembly, Drive Side (Optional)

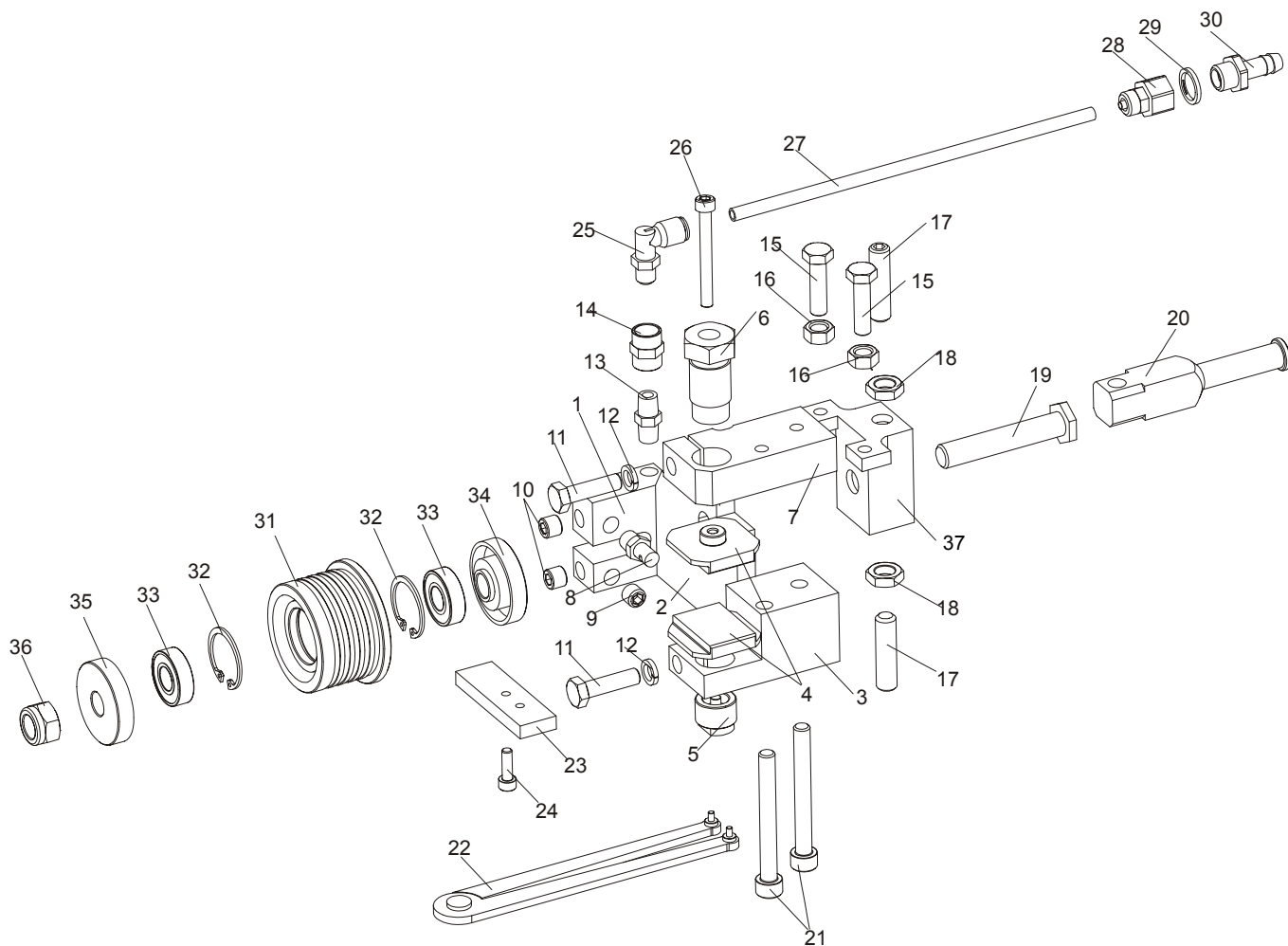

REF	DESCRIPTION (◆ Indicates Parts Available In Assemblies Only)	PART#	QTY.
	BLADE GUIDE ASSEMBLY,DRIVE SIDE, EXTENDED (for optional use with 1 1/2" blades)	093768	1
	NOZZLE & LOWER BLOCK MOUNT WELDMENT	093765	1
1	BLOCK WELDMENT, NOZZLE MOUNTING	087751	1
2	PLATE WELDMENT, MAIN	093766	1
3	BLOCK, LOWER PAD MOUNT (LEFT)	093767	1
4	BLOCK, BLADE GUIDE ZINC-PLATED	093430-1	2
5	SCREW, LOWER PAD ADJUSTMENT ZINC-PLATED	090945-1	1
6	BOLT, UPPER BLOCK ADJUSTMENT ZINC-PLATED	089515-1	1
7	BLOCK, UPPER PAD MOUNT ZINC-PLATED	093762-1	1
8	NOZZLE, BLADE WATER LUBE	016637	1
9	FITTING, 1/8 NPT SOCKET PIPE PLUG	P30127	1
10	PLUG, M10X1 DIN906 BN40 ZINC-PLATED	F81015-3	2
11	BOLT, M8X30 DIN933 A2-70 STAINLESS STEEL	F81002-27	2
12	WASHER, 8.2 SPLIT LOCK ZINC	F81054-4	2
13	NIPPLE, 1/8 DRY SEAL	P02764	1
14	FITTING, 1/8FPT COUPLING	P05748	1
15	BOLT, M8X30 DIN933 A2-70 STAINLESS STEEL	F81002-27	2
16	NUT, M8 DIN 934 A2-70 STAINLESS STEEL	F81032-7	2
17	SCREW, M10X1X40 DIN913 A2-70 STAINLESS STEEL SET	F81015-2	2

18	NUT, PN-EN ISO 8675-M10X1-04-ST-A2 HEX THIN W/FINE THREAD	F81033-10	2	
19	BOLT, EXT.BLADE GUIDE ROLLER LONG ZINC-PLATED	092940-1	1	
20	SHAFT, BLADE GUIDE MOUNT ZINC-PLATED	088255-1	1	
21	SCREW, M8X40-8.8 HEX SOCKET HEAD CAP ZINC	F81002-29	2	
22	SPANNER, 62860-3 (Perschmann) ADJUSTABLE	090949	1	
	PLATE, BLADE GUIDE ADJUSTMENT COMPLETE	090951	1	
23	PLATE, BLADE GUIDE ADJUSTMENT ZINC-PLATED	090951-1	1	
24	SCREW, M5X16-8.8 HEX SOCKET HEAD CAP ZINC	F81000-25	1	
25	ELBOW, 90 DEG 1/8MPT 1/4 TUBE SWIVEL	P09736	1	
26	SCREW, M5x45 DIN912 A2-70 HEX SOCKET HEAD CAP STAINLESS STEEL	F81000-24	1	
	FITTING, 10/6.35 COMPLETE REDUCER	092782	1	
27	CABLE, COMPLETE REDUCER FITTING	092785	1	
28	FITTING, MV13/06 nr 13700 (RECTUS)	092784	1	
29	SEAL, G1/4 866-014-000-0 (REXROTH)	090809	1	
30	BUSHING, GT13/09 nr 13539 (RECTUS)	092783	1	
	ROLLER, BLADE GUIDE EXTENDED W/BEARINGS	092939	1	
31	ROLLER, BLADE GUIDE EXTENDED	087890	1	
32	RING, W28 INSIDE RETAINING	F81080-9	2	
33	BEARING, 6001 2RSR (FAG, SKF)	087893	2	
34	RING, ZINC-PLATED SPACER	087892-1	1	
35	RING, ZINC-PLATED SPACER	087891-1	1	
36	NUT, M12-8 HEX NYLON ZINC LOCK	F81034-2	1	
37	BLOCK, BLADE DEFLECTION ADJUSTMENT ZINC-PLATED	087756-1	1	

2.4 Idle Side Blade Guide Assembly, Optional (LMS)

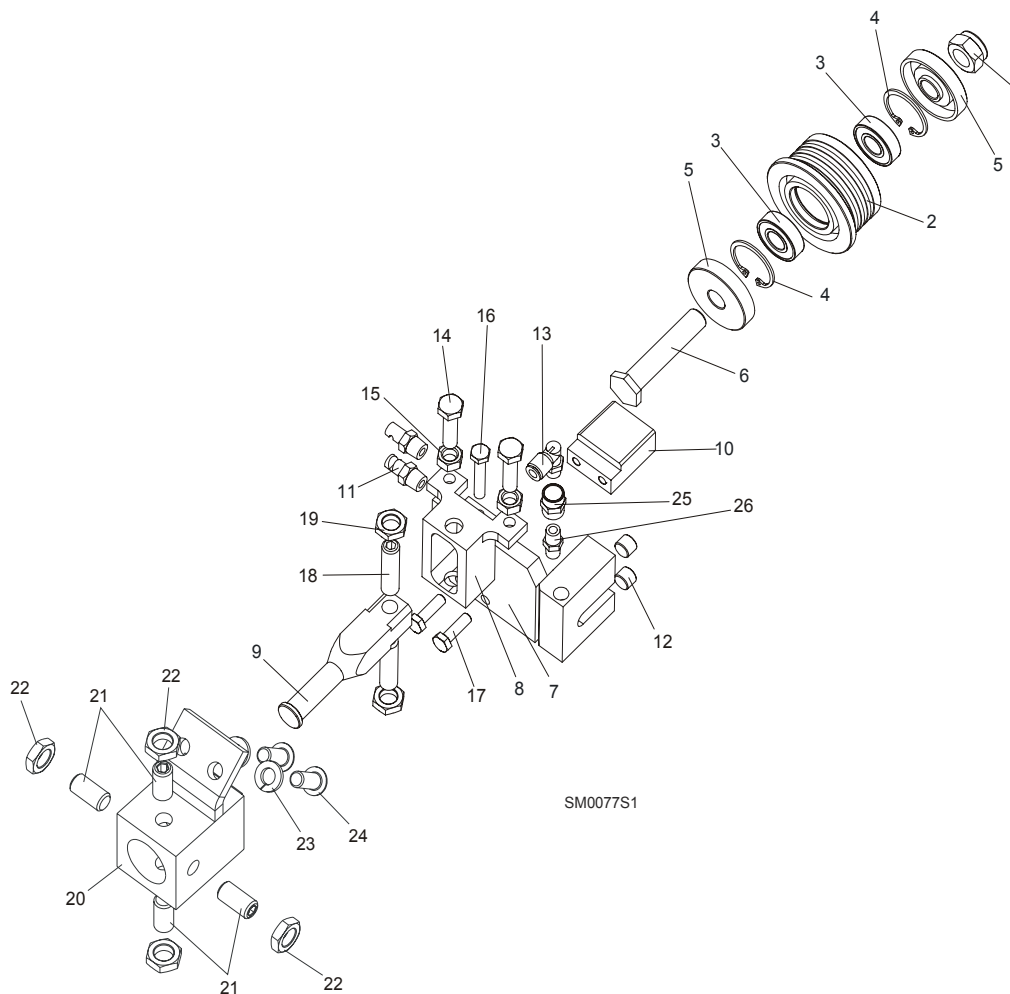

REF	DESCRIPTION (◆ Indicates Parts Available In Assemblies Only)	PART#	QTY.
	BLADE GUIDE ASSEMBLY, IDLE SIDE	087749	1
	BLADE GUIDE ASSEMBLY, IDLE SIDE. EXTENDED (for optional use with 1 1/2" blades)	092996	1
	Roller, Blade Guide Narrow W/Bearings	088261	1
	Roller, Blade Guide W/Bearings Extended (for optional use with 1 1/2" blades)	092939	1
1	Nut, M12-8 Hex Nylon Zinc Lock	F81034-2	1
2	Roller, Blade Guide Narrow	087889	1
	Roller, Blade Guide Extended (for optional use with 1 1/2" blades)	087890	1
3	Bearing, 6001 2RSR NACHI	087893	2
4	Ring, W28 Inside Retaining	F81090-9	2
5	Washer, Spacer	087891	2 (1)
	Washer, Spacer (used with the Extended Roller only) ¹	087892-1	1
6	Bolt, Blade Guide Roller Zinc-Plated	087761-1	1
	Bolt, Blade Guide Roller Zinc Plated (used with the Extended Roller only)	092940-1	1
7	Block Weldment, Nozzle Zinc-Plated	087750-1	1
8	Block, Zinc-Plated Roller Guide Adjuster	087756-1	1
9	Shaft, Zinc-Plated Blade Guide Mount	088255-1	1

10	Block, Blade Guide Zinc	096956-1	1	
11	Nozzle, Blade Lube Spray	033479	2	
12	Plug, M10x1 DIN 906 BN40 "BOSSARD"	F81015-3	2	
13	Fitting, 90° Elbow 1/8NPT-1/4 Tube Swivel	P09736	1	
14	Bolt, M8x30 DIN933 A2-70 Stainless Steel	F81002-27	2	
15	Nut, M8 DIN934 A2-70 Stainless Steel	F81032-7	2	
16	Bolt, M6x30 DIN933 A2-70 Stainless Steel	F81001-37	1	
17	Bolt, M6x20-8.8 Hex Head Full Thread Zinc	F81001-2	2	
18	Screw, M10x1x40 DIN913 Stainless Steel Set	F81015-2	2	
19	Nut, M10x1-04-ST-A2 ISO 8675 Thin	F81033-10	2	
20	BLOCK WELDMENT, PAINTED BLADE GUIDE MOUNT	088292-1	1	
21	SCREW, M10X1X20 DIN913 STAINLESS STEEL SET	F81015-1	4	
22	NUT, M10x1-04-ST-A2 ISO 8675 THIN	F81033-10	4	
23	WASHER, 8.2 SPLIT LOCK ZINC	F81054-4	2	
24	BOLT, 5/16-18X3/4 SOCKET HEAD	F05006-102	2	
25	FITTING, 1/8FPT COUPLING	P05748	1	
26	NIPPLE, 1/8 DRY SEAL	P02764	1	

¹ Used only from the flanged side of the roller

2.5 Blade Guide Assembly, Drive Side

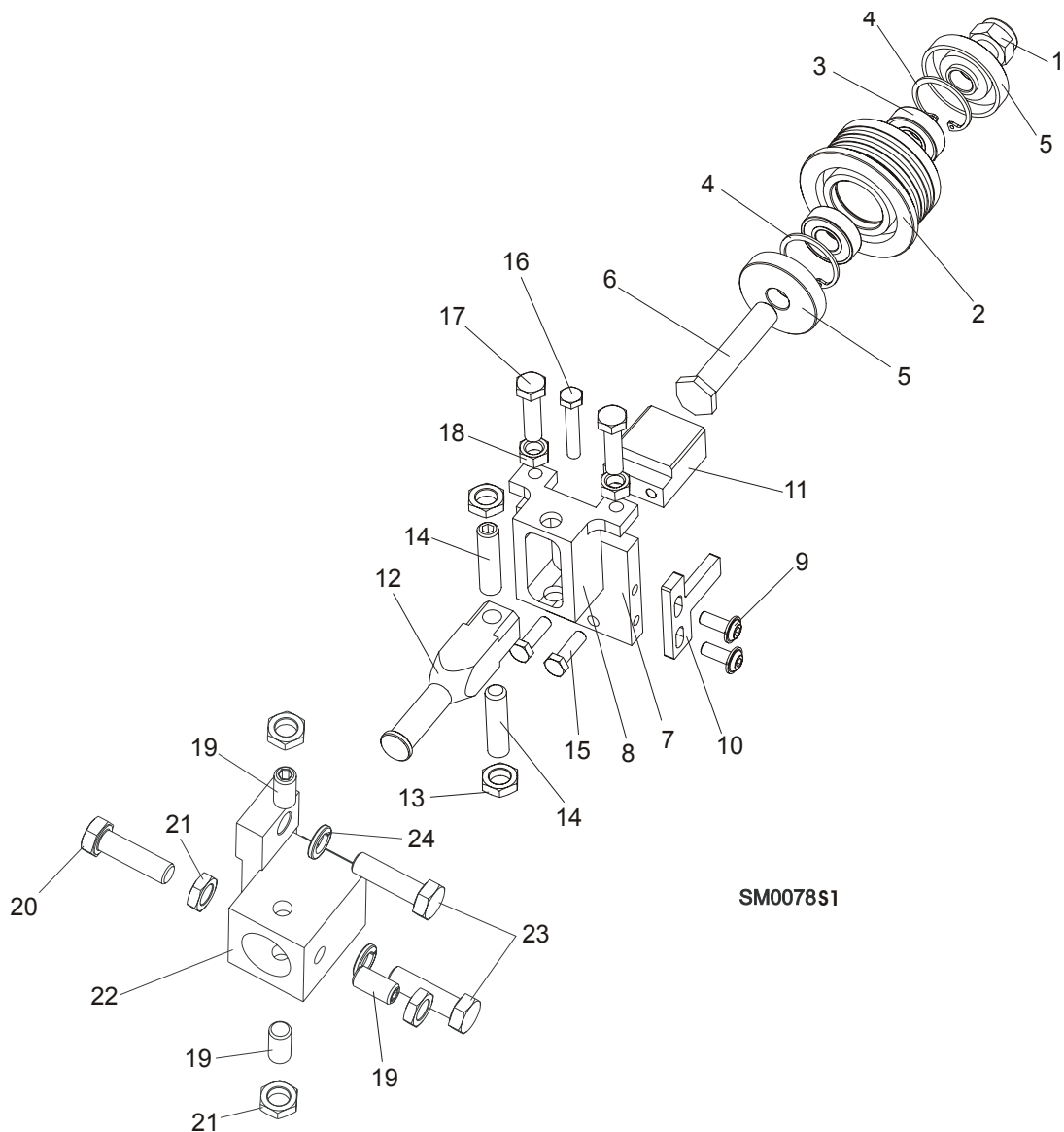

REF	DESCRIPTION (◆ Indicates Parts Available In Assemblies Only)	PART#	QTY.
	BLADE GUIDE ASSEMBLY, DRIVE SIDE	087748	1
	BLADE GUIDE ASSEMBLY, DRIVE SIDE , Extended (for optional use with 1 1/2" blades)	092995	1
	Roller, Blade Guide Narrow W/Bearings	088261	1
	Roller, Blade Guide W/Bearings Extended (for optional use with 1 1/2" blades)	092939	1
1	Nut, M12-8 Hex Nylon Zinc Lock	F81034-2	1
2	Roller, Blade Guide Narrow	087889	1
	Roller, Blade Guide Extended (for optional use with 1 1/2" blades)	087890	1
3	Bearing, 6001 2RSR NACHI	087893	2
4	Ring, W28 Inside Retaining	F81090-9	1
5	Washer, Spacer	087891	2 (1)
	Washer, Spacer (used with the Extended Roller only) ¹	087892-1	1

6	Bolt, Blade Guide Roller Zinc-Plated	087761-1	1	
	Bolt, Blade Guide Roller Zinc Plated (used with the Extended Roller only)	092940-1	1	
7	Plate, Zinc-Plated Blade Guide Mounting	087753-1	1	
8	Block, Zinc-Plated Roller Guide Adjuster	087756-1	1	
9	Screw, M6x16 BN 11252 "BOSSARD"	F81001-24	2	
10	Wiper, Blade Zinc-Plated	087757-1	1	
11	Block, Blade Guide Zinc	096956-1	1	
12	Shaft, Zinc-Plated Blade Guide Mount	088255-1	1	
13	Nut, M10x1-04-ST-A2 ISO 8675 Thin	F81033-10	2	
14	Screw, M10x1x40 DIN913 Stainless Steel Set	F81015-2	2	
15	Bolt, M6x20-8.8 Hex Head Full Thread Zinc	F81001-2	2	
16	Bolt, M6x30 DIN933 A2-70 Stainless Steel	F81001-37	1	
17	Bolt, M8x30 DIN933 A2-70 Stainless Steel	F81002-27	2	
18	Nut, M8 DIN934 A2-70 Stainless Steel	F81032-7	2	
19	Screw, M10X1X20 DIN913 Stainless Steel Set	F81015-1	3	
20	BOLT, M10X1X25 DIN 933 STAINLESS STEEL	F81003-28	1	
21	NUT, M10x1-04-ST-A2 ISO 8675 THIN	F81033-10	4	
22	BLOCK WELDMENT, BLADE GUIDE MOUNT	087744	1	
23	BOLT, M10X35-8.8 HEX HEAD FULL THREAD ZINC	F81003-17	2	
24	WASHER, 10.2 SPLIT LOCK ZINC	F81055-2	2	

¹ Used only from the flanged side of the roller

2.6 Blade Guide Arm & Rollers

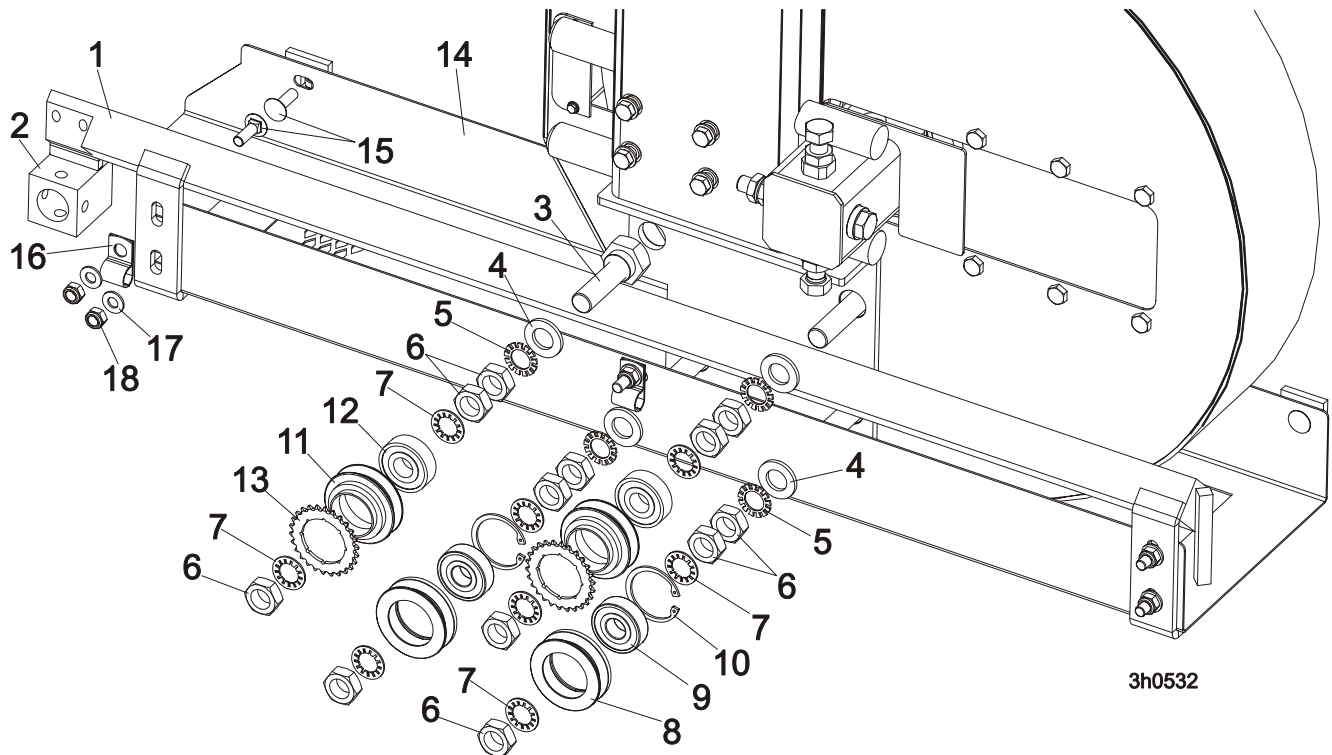

REF	DESCRIPTION (◆ Indicates Parts Available In Assemblies Only)	PART #	QTY.	
1	BLADE GUIDE ARM WELDMENT	087018-1	1	
2	BLOCK WELDMENT, PAINTED BLADE GUIDE MOUNT	088292-1	1	
3	BOLT, BLADE GUIDE ARM ROLLER CAM	086508-1	4	
4	WASHER, 17 FLAT	F81058-1	4	
5	WASHER, 5/8" EXTERNAL STAR	F05011-26	4	
6	NUT, 5/8-18 HEX JAM	F05010-11	12	
7	WASHER, 5/8" INTERNAL STAR	F05011-25	8	
	ROLLER ASSEMBLY, BLADE GUIDE ARM WITH BEARING	093855	2	
8	Roller, Blade Guide Arm V-Groove	093856-1	1	◆
9	Bearing, 6203-2RSP6-5/8 CX	095087	1	
10	Ring, W40 Retaining	F81090-3	1	
	ROLLER ASSEMBLY, BLADE GUIDE ARM WITH BEARING AND SPROCKET	A09932	2	
11	Roller, Blade Guide Arm Drive	S09930	1	◆
12	Bearing, 6203-2RSP6-5/8 CX	095087	1	
13	Sprocket, #25 26-Tooth	015939	1	◆
14	GUIDE, BLADE	087042-1	1	
15	BOLT, M8x20-8.8 Fe/Zn5 PN-M/82406	F81002-11	7	
16	CLAMP, 1/2EMT COATED	P07584	2	
17	WASHER, 8.4 FLAT ZINC	F81054-1	7	
18	NUT, M8-8-B HEX NYLON ZINC LOCK	F81032-2	7	

2.7 Blade Guide Arm Drive Assembly

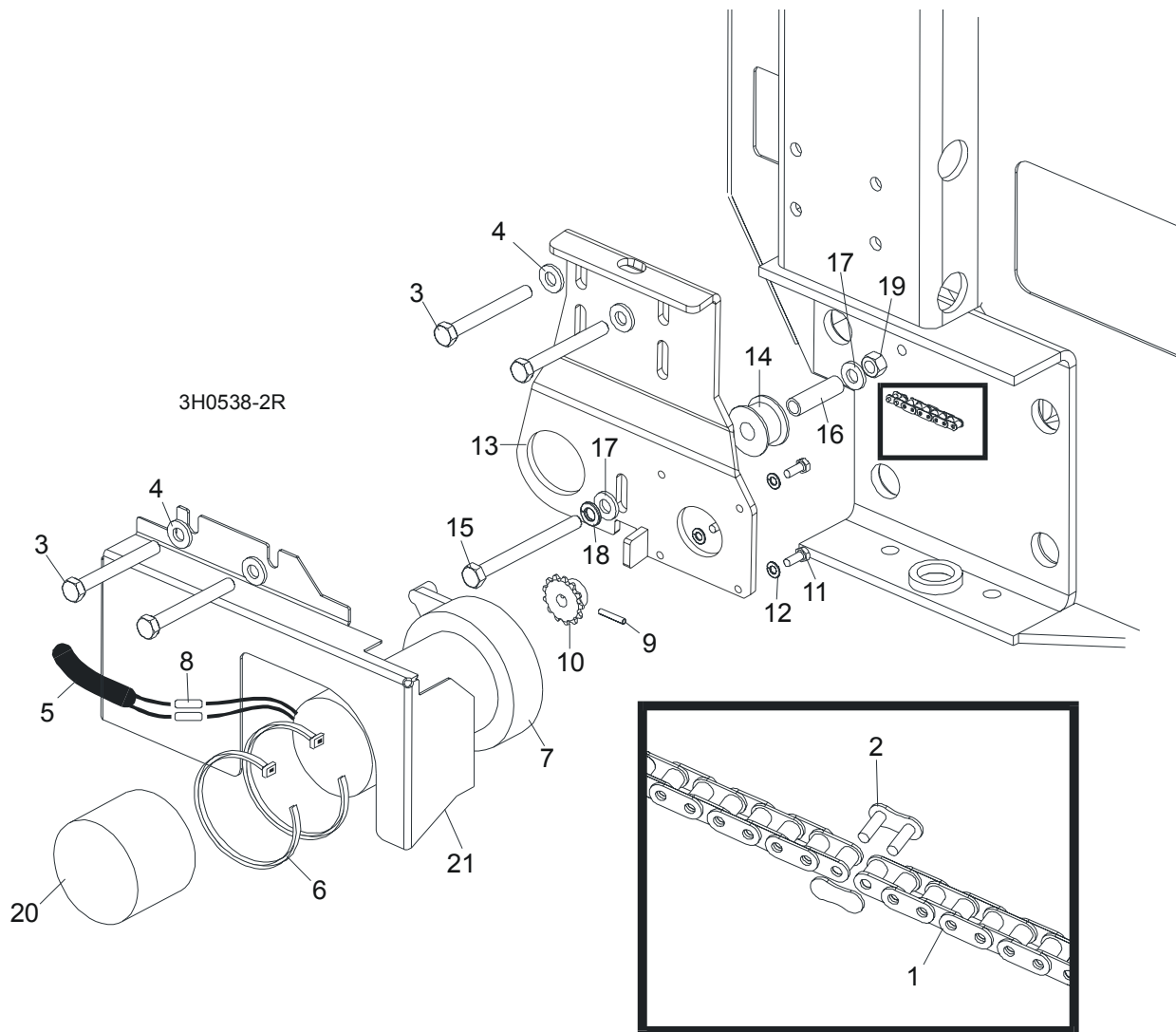

REF	DESCRIPTION (◆ Indicates Parts Available In Assemblies Only)	PART #	QTY.
1	CHAIN, #25 X 20 1/4"	P09984	1
2	LINK, #25 MASTER	P09983	1
3	BOLT, 5/16-18 X 2 3/4" HEX HEAD GRADE 5	F05006-28	4
4	WASHER, 8.4 FLAT	F81054-1	4
5	TUBE, 3/8" X 1/2" NEOPRENE	R01897	0,75 m
6	WRAP, 1/4" X 6" TIE	F05089-1	2
	DRIVE ASSEMBLY, BLADE GUIDE ARM	091005	1
	Motor Assembly, Blade Guide Arm Replacement	A10365	1
7	Motor, Blade Guide Arm 53:1 Gear	P09698-1	1
	Housing, Klauber Motor End	P12756	1
	Gear Kit, Klauber Motor Replacement	P12569	1
	Brush Kit, Gear Motor Replacement	P12800	1
	Shaft Kit, Klauber Gear Motor Replacement	009695	1
8	Connector, 14 Gauge Butt	F04875-1	2

9	Pin, 1/8" X 3/4" Roll	F05012-6	1	
10	Sprocket, Gear Motor #25 14-Tooth	P09970	1	
11	Screw, #10-32 x 1/2" Hex Head	F05004-60	4	
12	Washer, 5.1 Split Lock	F81052-2	4	
	Instruction Sheet, Blade Guide Arm Motor	A10353-296	1	
13	Bracket, Blade Guide Arm Motor Mount	087994-1	1	
14	Roller, Blade Guide Arm Chain Idler	S09999	1	
15	Bolt, M8x90-8.8 Hex Head Full Thread	F81002-16	1	
16	Spacer, 5/16" I.D. X 1 1/2"	S09996	1	
17	Washer, 5/16" SAE Flat	F81054-1	3	
18	Washer, 8.2 Split Lock	F05011-13	1	
19	Nut, M8-8-B Hex Lock	F81032-1	1	
20	Boot, Gear Motor Weather	023720	1	
21	COVER, BLADE GUIDE ARM MOTOR	093460-1	1	

SECTION 3 BLADE WHEELS & TENSIONER

3.1 Blade Drive Assembly

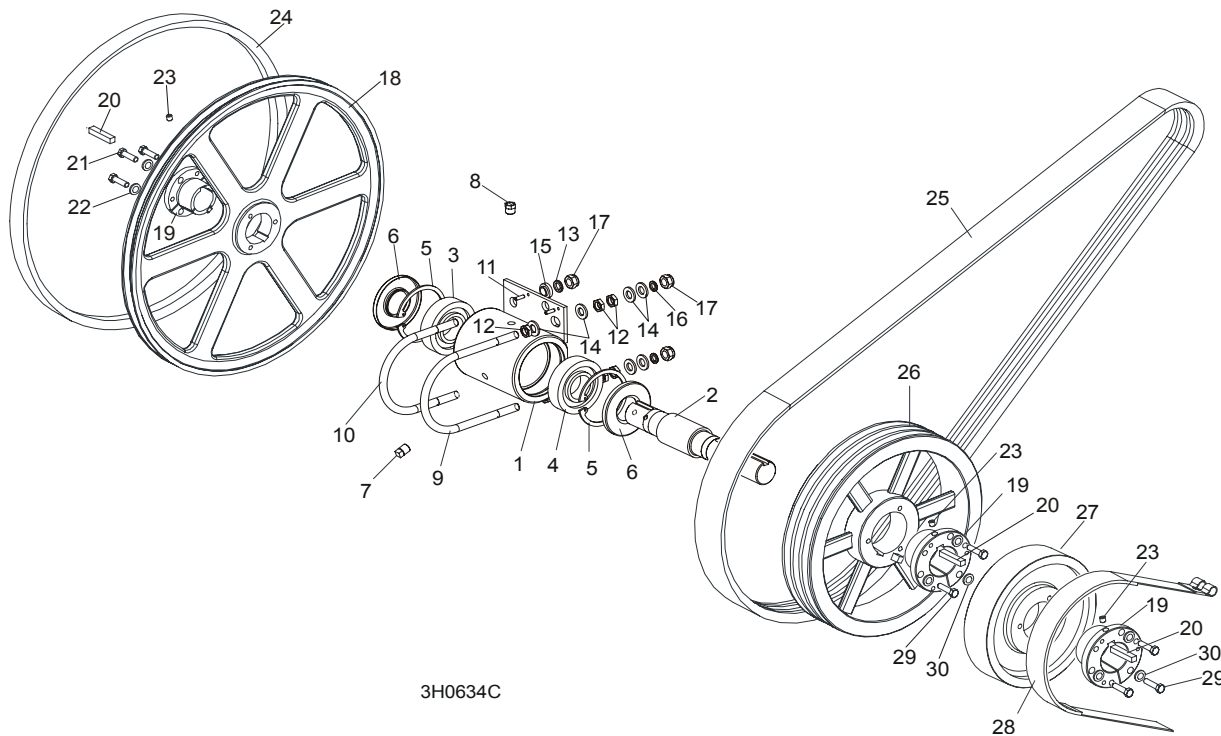

REF	DESCRIPTION (◆ Indicates Parts Available In Assemblies Only)	PART #	QTY.
	BEARING ASSEMBLY, DRIVE	086291	1
1	Housing, Blade Wheel Drive Bearing	086293	1
2	Shaft, Blade Wheel Drive	086292	1
3	Bearing, Blade Wheel Drive NJ308	085939	1
4	Bearing, Blade Wheel Drive #6308	085940	1
5	Ring, 90mm Interior Retaining #117	F04254-17	2
6	Seal, Drive Bearing #CR15890	P10206	2
7	Plug, 1/4" NPT Square Head	P05498	1
8	Plug, 1/4" NPT Vented	P12868	1
9	Bolt, 1/2-13 Long U	S10207-1P	1
10	Bolt, 1/2-13 Short U	S10207-2P	1
11	Pin, 3/16" X 5/8" Roll	F05012-22	2
12	Nut, M12-04-A Hex Jam	F81034-6	6
13	Washer, 12.2 Split Lock	F81056-2	2
14	Washer, 13 SAE Flat	F81056-1	8
15	Spacer, Zinc	086769-1	2
16	Washer, 10.2 Split Lock Zinc	F81055-2	2
17	Nut, M12-8 Hex Nylon Lock	F81034-2	4
	WHEEL KIT, DRIVE SIDE BLADE	014562	1
18	Wheel, Drive Side Blade	016284	1
19	Bushing, Modified 1 9/16" P1	087214	1
20	KEY, 9.5h7x9.5x3.8	087384	3
21	BOLT, UNC 1/4"x1 1/2"-8.8 ZINC DIN933 HEX HEAD	F05005-31	3

22	WASHER, 1/4" UNC ZINC SPLIT LOCK	F81052-21	3	
23	SCREW, M8x8-33H ZINC HEX SOCKET SET FLAT POINT	F81014-1	3	
24	BELT, BLADE WHEEL B57	P04185	1	
25	BELT, 3BX72 DRIVE (D42)	014085	1	
	BELT, 3BX73 DRIVE (D38)	091548	1	
	BELT, 3BX74 DRIVE (E25HP 50HZ)	014249	1	
26	PULLEY, 3B5V124 SPECIAL DRIVE	087203-1	1	
27	WHEEL, BRAKE	087204-1	1	
28	STRAP, METAL-BACKED BRAKE	014391	1	
29	BOLT, M8X35-8.8 ZINC HEX HEAD FULL THREAD	F81002-13	6	
30	WASHER, 8.2 ZINC SPLIT LOCK	F81054-4	6	

3.2 Idle Blade Wheel Assembly

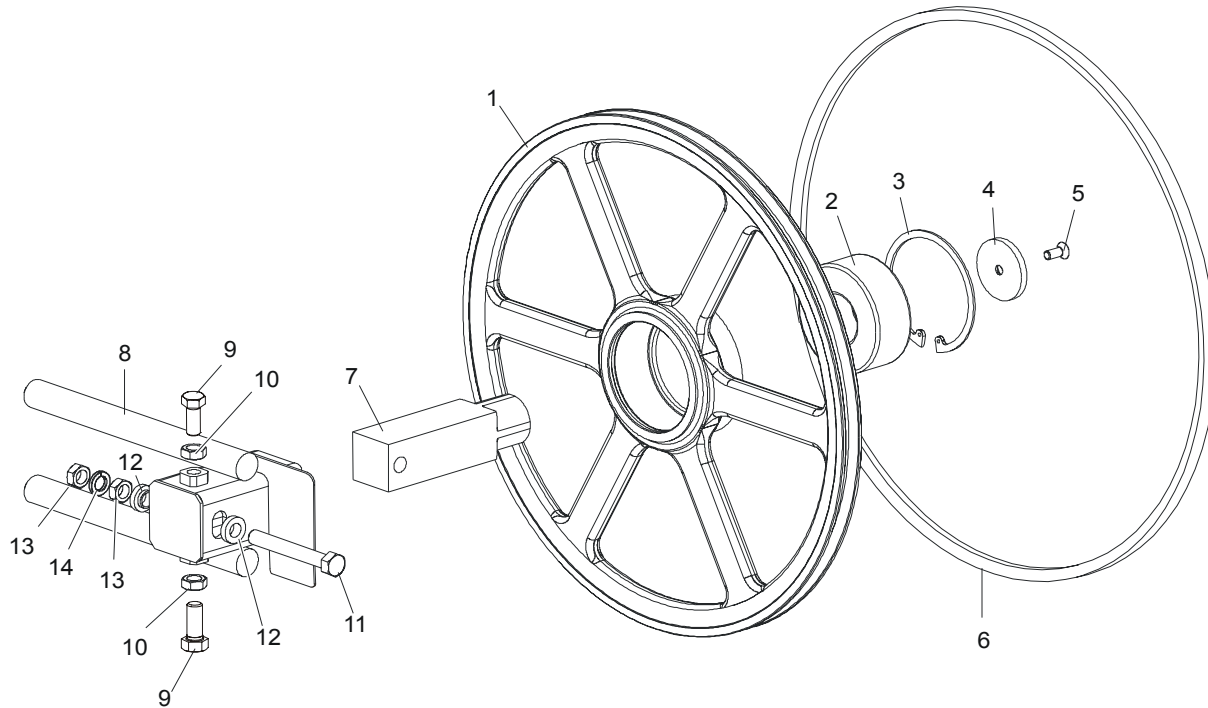

SM0241C

REF	DESCRIPTION (◆ Indicates Parts Available In Assemblies Only)	PART #	QTY.	
	WHEEL ASSEMBLY, IDLE SIDE BLADE	016120	1	
1	Wheel, Idle Side Blade	016013	1	◆
2	Bearing, Idle Side Blade Wheel 3309 B.2RSR TVH FAQ	086428	1	
3	Ring, 100mm Internal Retaining Beveled	F04254-28	1	
4	RETAINER, ZINC	095929-1	1	
5	BOLT, M10x25 -10.9- Fe/Zn5 DIN 7991	F81003-82	1	
6	BELT, BLADE WHEEL B57	P04185	1	
7	SHAFT, IDLE BLADE WHEEL	095732	1	
8	HOUSING, IDLE BLADE WHEEL SHAFT	087665	1	
9	BOLT, 1/2-20 X 1 1/2" HEX HEAD GRADE 5	F05008-53	2	
10	NUT, 1/2-20 HEX JAM	F05010-16	2	
11	BOLT, M12x1,25x100-8.8 HEX HEAD FULL THREAD GRADE 2	F81004-41	1	
12	SPACER, 1/2" I.D. FLANGED	086769-1	2	
13	NUT, M12x1,25 8.8 HEX JAM	F81034-5	2	
14	WASHER, 12.2 SPLIT LOCK	F81056-2	1	

3.3 Hydraulic Blade Tensioner Assembly

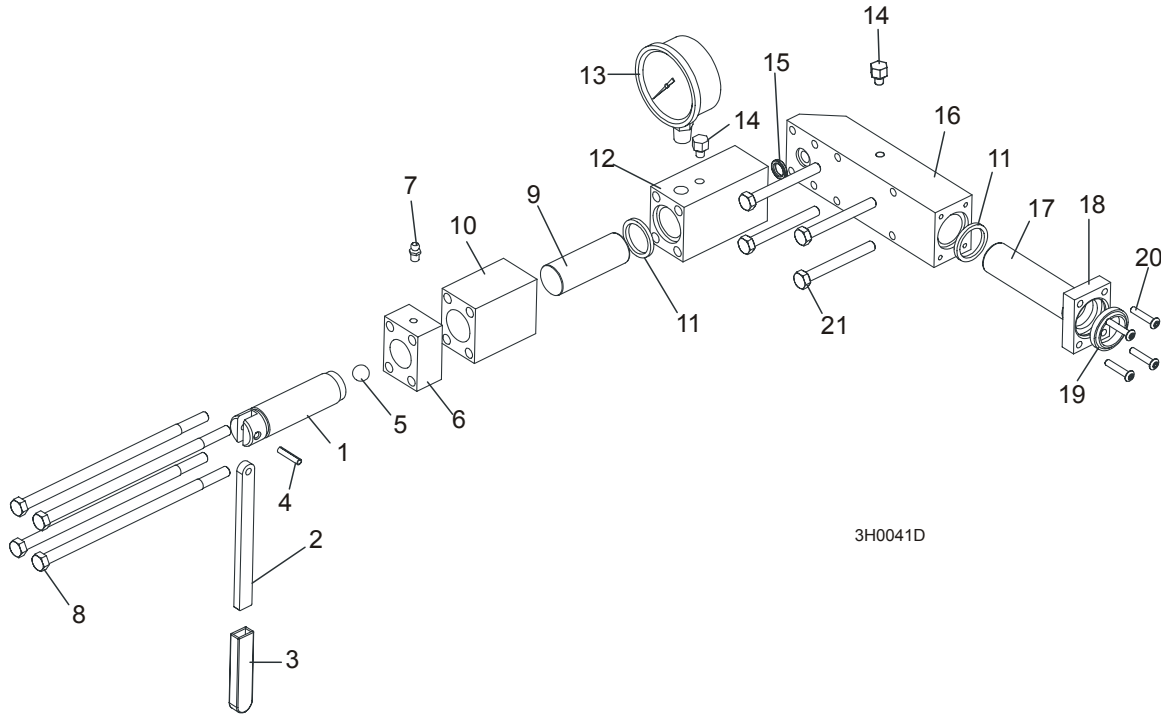

3H0041D

REF	DESCRIPTION (◆ Indicates Parts Available In Assemblies Only)	PART #	QTY.
	HYDRAULIC BLADE TENSIONER ASSEMBLY	A10054	1
	Handle Assembly, Hydraulic Blade Tensioner Screw	A12294	1
1	Screw, Hydraulic Blade Tensioner	S10056	1
2	Handle, Hydraulic Tensioner Screw	095930	1
3	Sleeve, Plastic Handle	P08072	1
4	Pin, 3/16" x 7/8" Roll	F05012-11	1
5	Ball, 1/2" Steel	P02720	1
6	Block, Threaded Tensioner End	S10062	1
7	Fitting, 1/4-28 Grease	P05060	1
	Instruction Sheet, Tensioner Screw	A12294-518	1
8	Bolt, 5/16-18 X 7 1/2" Hex Head Grade 5	F05006-43	4
9	Piston, Hydraulic Tensioner Front 2 3/4" Long	S10060	1
10	Block, Piston Guide	S10061	1
11	Seal, 1" Diameter	P10051	2
12	Block, Hydraulic Tensioner Gauge Mounting	S10140	1
13	Gauge, 3000 PSI	090552	1
14	Plug, Hydraulic Tensioner Fill	P10065	2
15	Ring, 5/8" X 3/32" Square "O"	P10377	1
16	Block, Rear Tensioner Piston	S10142	1
17	Piston, Hydraulic Tensioner Rear 3 5/8" Long	S10059	1
18	Block, Rear Piston End	S10089	1
19	Wiper, 1" Diameter	P10053	1
20	Bolt, #10-24 X 1" Socket Button Head	F05004-43	4
21	Bolt, 5/16-18 X 2 3/4" Hex Head Grade 5	F05006-28	4
	Instruction Sheet, Hydraulic Tensioner Installation	A10136-272	1

SECTION 4 SAW HEAD

4.1 Middle Throat Screw

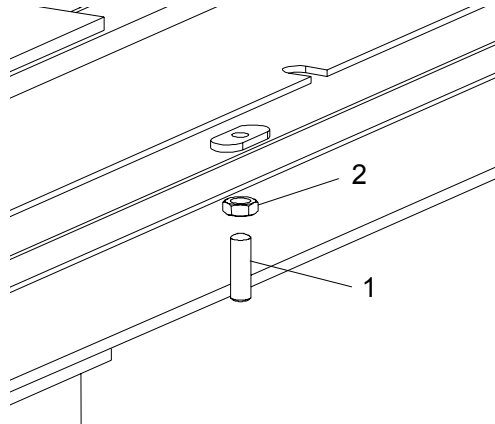

REF	DESCRIPTION (◆ Indicates Parts Available In Assemblies Only)	PART #	QTY.	
1	SCREW, M10X40-45H OVAL POINT SOCKET SET, ZINC	F81003-61	1	
2	NUT, M10-8-B HEX JAM, ZINC	F81033-3	1	

4.2 Water Lube Solenoid Valve

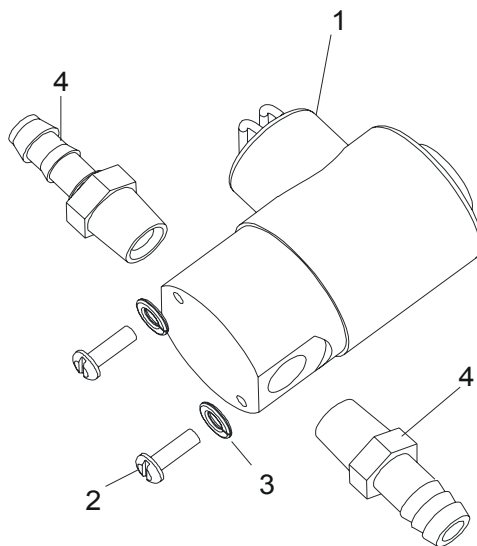

3H0310B

REF	DESCRIPTION (◆ Indicates Parts Available In Assemblies Only)	PART #	QTY.	
1	VALVE, WATER LUBE SOLENOID	016140	1	
2	SCREW, #10-32X1/2" CROSS SLOT ROUND HEAD	F05004-60	2	
3	WASHER, 5.1 SPLIT LOCK	F81052-2	2	
4	FITTING, 1/4" MALE NPT 3/8" HOSE BARB	P04682	2	

4.3 Clutch Lever Assembly

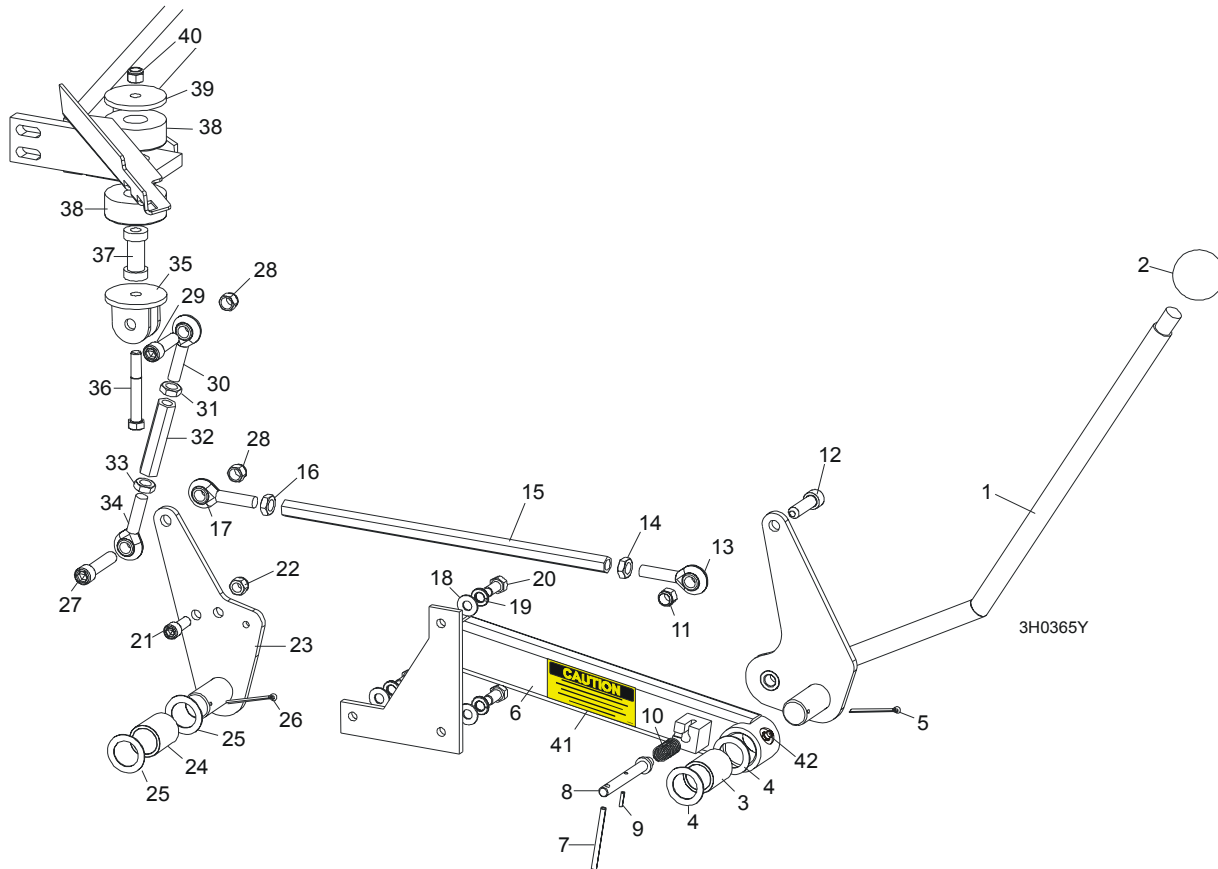

REF	DESCRIPTION (◆ Indicates Parts Available In Assemblies Only)	PART #	QTY.	
	HANDLE ASSEMBLY, EXTENDED CLUTCH/BRAKE	086242	1	
1	Lever, Clutch/Brake	086339-1	1	◆
2	Knob, Plastic Round	086337	1	
3	Bushing, Clutch/Brake Pivot	P05041	1	
4	Washer, Clutch/Brake Pivot	087051-1	2	
5	Pin, 1/8" X 1 3/4" Cotter	F05012-43	1	
6	Extension Weldment, Clutch Handle	086244-1	1	
7	Pin, 3/16 x 2 1/2" Roll	F05012-27	1	
8	Pin, Clutch Detent	086243	1	◆
9	Pin, 1/8" x 9/16" Roll	F05012-30	1	
10	Spring, .58" OD x 1 1/8"	021243	1	
11	Nut, 7/16-20 Nylon Lock	F05010-83	1	
12	Screw, 7/16-20 x 1 1/2" Socket Head	F05007-55	1	
13	Rod End, 7/16-20 Left Hand Thread	P11578	1	
14	Nut, 7/16-20 Hex Jam Left Hand Thread	F05010-87	1	
15	Rod, Clutch Extension	015073	1	
16	Nut, 7/16-20 Hex Jam	F05010-38	1	
17	Rod End, 7/16-20 Right Hand Thread	P11579	1	
18	WASHER, 8.4 SAE FLAT	F81054-1	3	
19	WASHER, 8.2 SPLIT LOCK	F81054-4	3	

20	BOLT, M8X20-8.8-B HEX HEAD	F81002-4	3	
21	BOLT ,M10 X 25 SOCKET HEAD	F81003-32	1	
22	NUT, M10-8-B HEX NYLON LOCK	F81033-1	1	
23	PLATE WELDMENT, CLUTCH PIVOT	087086-1	1	
24	BUSHING, CLUTCH/BRAKE PIVOT	P05041	1	
25	WASHER, CLUTCH/BRAKE PIVOT	087051-1	2	
26	PIN, 1/8" X 1 3/4" COTTER	F05012-43	1	
27	SCREW, 7/16-20 X 2" SOCKET HEAD	F05007-120	1	
28	NUT, 7/16-20 HEX NYLON LOCK	F05010-83	2	
29	SCREW, 7/16-20 X 2" SOCKET HEAD	F05007-120	1	
	TURNBUCKLE ASSEMBLY, CLUTCH/BRAKE LEVER	A12304	1	
	TURNBUCKLE ASSEMBLY, 3 3/4" CLUTCH/BRAKE LEVER (50Hz Electric Only)	A11576	1	
30	Rod End, 7/16-20 Right Hand Thread	P11579	1	
31	Nut, 7/16-20 Hex Jam	F05010-38	1	
32	Turnbuckle, 3" Clutch/Brake Lever	S11577	1	
	Turnbuckle, 3 3/4" Clutch/Brake Lever (50Hz Electric Only)	S12262	1	
33	Nut, 7/16-20 Hex Jam Left Hand Thread	F05010-87	1	
34	Rod End, 7/16-20 Left Hand Thread	P11578	1	
35	BRACKET, CLUTCH MOUNT	W12411-1	1	
36	BOLT, M10X70-8.8 HEX HEAD, ZINC	F81003-20	1	
37	SPACER, MOTOR MOUNT VIBRATION BUSHING	095928	1	
38	BUSHING, MOTOR MOUNT VIBRATION	P05032	2	
39	WASHER, 3/8" I.D. X 2 1/4" O.D. X 3/16" THICK	S12412-0	1	
40	NUT, 3/8-16 NYLON LOCK	F05010-10	1	
41	DECAL, PLACE PIN IN DETENT POSITION	085089	1	
42	FITTING, M6 GREASE	086280	1	

4.4 Brake Assembly

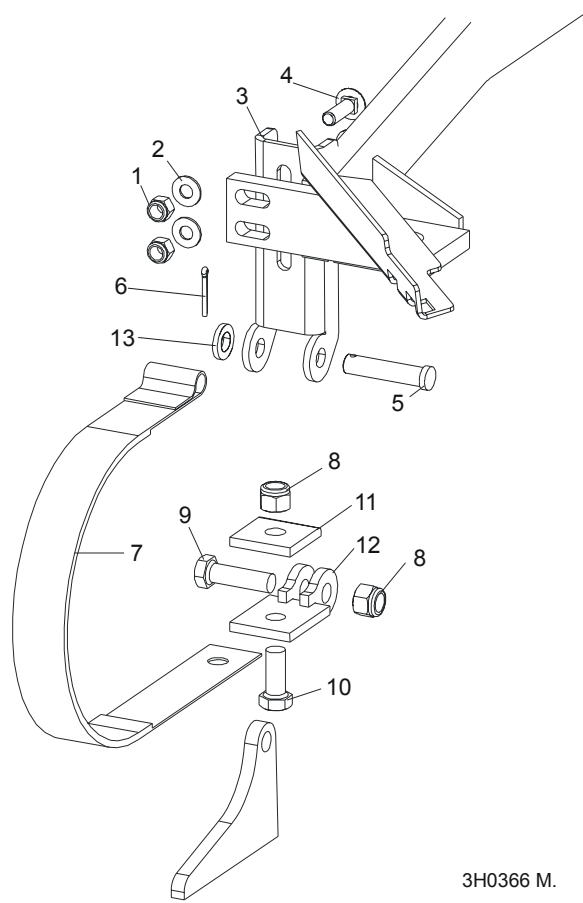

3H0366 M.

REF	DESCRIPTION (◆ Indicates Parts Available In Assemblies Only)	PART #	QTY.	
	STRAP RETROFIT, SUPER BRAKE	014441	1	
1	Nut, 3/8-16 Nylon Lock	F05010-10	2	
2	Washer, 10.5 Flat	F81055-1	2	
3	Bracket, Upper Super Brake Strap Mount	014395	1	
4	Bolt, 3/8-16 x 1 1/4" Carriage Head Grade 5	F05007-127	2	
5	Pin, 1/2" x 2 1/4" Clevis	F05012-81	1	
6	Pin, 1/8" x 1" Cotter	F05012-1	1	
7	Strap, Upper Pivot Metal Brake	014391	1	
8	Nut, M12-8-B Nylon Lock	F81034-2	2	
9	Bolt, M12 x 40-8.8 Hex Head	F81004-4	1	
10	Bolt, M12 x 30-8.8 Hex Head	F81004-22	1	
11	Washer, Brake Strap Clamp	090063-1	1	
12	Bracket Weldment, Brake Lower Pivot Painted	092200-1	1	
13	Washer, 13 Flat Zinc	F81056-1	1	

4.5 Board Return Assembly

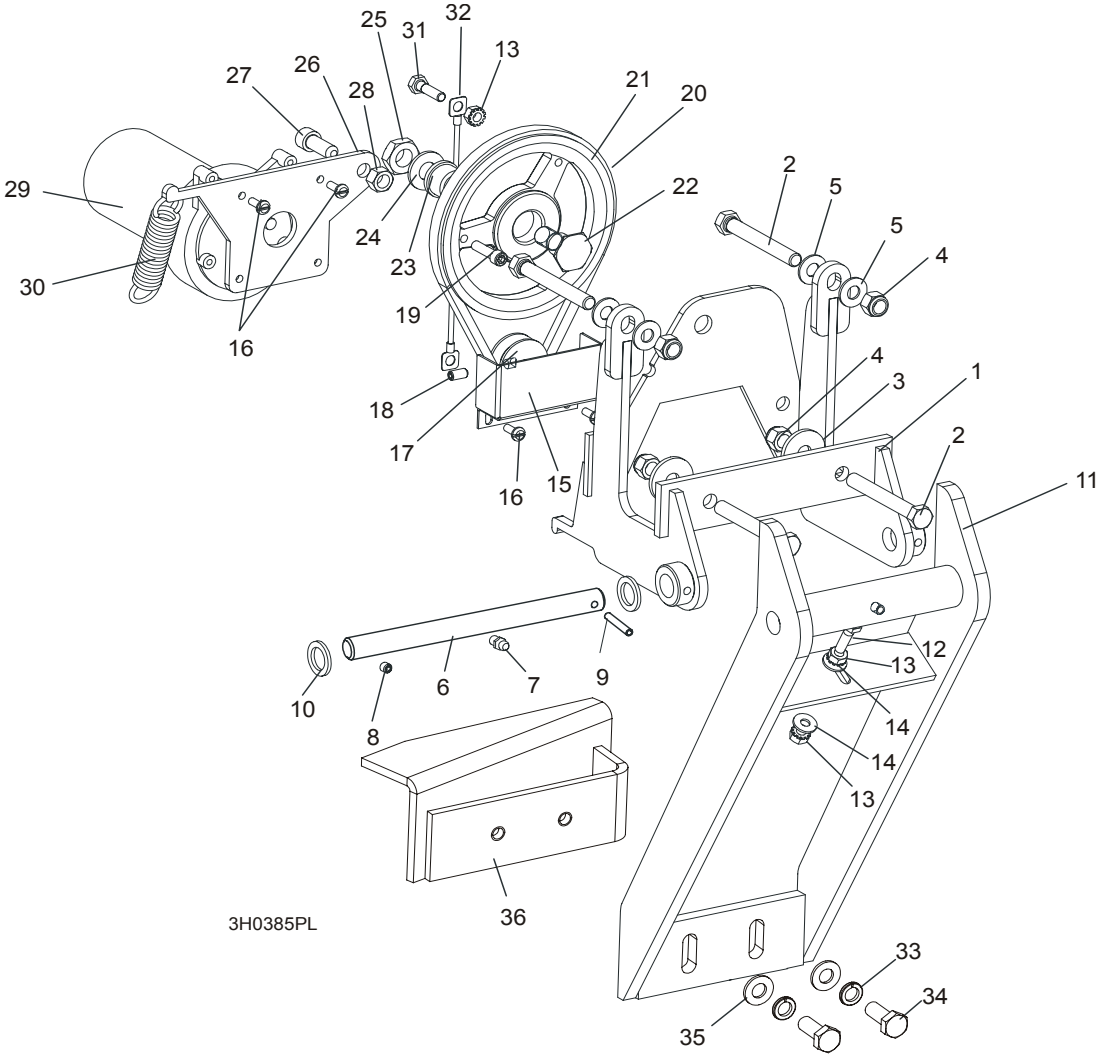

REF	DESCRIPTION (◆ Indicates Parts Available In Assemblies Only)	PART #	QTY.
	RETURN ASSEMBLY, BOARD	087839-1	1
1	Mount Weldment, Board Return	087788-1	1
2	Bolt, 3/8-16 x 3" Full Thread Hex Head	F05007-1	4
3	Washer, 1/8" x 1 1/4"	F81055-1	2
4	Nut, 3/8-16 Hex Nylon Lock	F05010-10	4
5	Washer, 10.5 Flat	F81055-1	4
6	Pin Kit, Board Return Replacement Pivot	087837	1
7	Fitting, M6 Grease	086280	1
8	Screw, M6 X 8 Black Oxide Socket Head Set Cup Point	F81013-1	1
9	Pin, 5 X 30 Roll	F81044-21	1
10	Washer, 5/8" x 15/16" x .094 Nylon	F05011-19	2
11	Arm Weldment, Board Return	087838-1	1
12	Screw, 1/4-20 x 1" Full Thread Hex Head Cap	F05005-101	1
13	Nut, 1/4-20 Self Locking	F05010-9	3

14	Washer, 6.5 Flat	F81053-11	2	
15	Guard, Board Return Belt	087985-1	1	
16	Screw, 10-32 x 1/2" Hex Head Machine	F05004-60	4	
17	Sheave, 1.42 x .32	015074	1	
18	Screw, 1/4-20 Socket Head Set Cup Point Nylon	F05005-105	1	
19	Screw, 1/4-28 x 1/4" Socket Head Cap	F05005-1	1	
20	Belt, 3L190	015477	1	
21	Sheave, OK50 x 1/2" Modified	015224	1	
22	Bolt, Idler Pulley Pivot	015221	1	
23	Bushing, 5/8" x 7/8" x 1/2" Bronze	P05135	1	
24	Washer, 13 Flat	F81056-1	1	
25	Nut, 1/2-20 Jam Nylon Lock	F05010-79	1	
26	Plate, Motor Pivot	087871-1	1	
27	Screw, M10 x 25-8.8 Black Oxide Socket Head Cap	F81003-32	1	
28	Nut, 3/8-16 Self Locking	F05010-25	1	
29	Motor, 53:1 ASA Gear	P09698-1	1	
30	Spring, 3/4" x 2 7/8" x 12 Gauge	015479	1	
31	Bolt, 1/4-20 x 1" Hex Head Grade 5	F05005-101	1	
32	Cable, Board Return	016090	1	
33	Washer, 10.2 Split	F81055-2	2	
34	Bolt, M10-1.5x25mm HH Gr8.8	F81003-11	2	
35	Washer, 10.5 Flat	F81055-1	2	
36	Angle, Board Return	087835-1	1	

4

Saw Head*Water Lube Assembly*

7	BOLT, 1/4-20 X 1/2" CARRIAGE HEAD	F05005-33	2	
8	CLAMP, 1/2" EMT HOSE	P07584	3	
9	WASHER, 6.5 FLAT ZINC	F81053-11	3	
10	NUT, 1/4-20 HEX LOCK	F05010-21	1	
11	NUT, 1/4-20 SELF-LOCKING	F05010-21	2	
	BOTTLE, 5-GALLON WATER COMPLETE	014637-1	1	
12	BOTTLE, 5-GALLON WATER	101295	1	
13	CAP, 5-GALLON WATER BOTTLE	036745	1	
14	CAP, VENT VALVE	061742	1	
15	FITTING, 3/4FPT X 3/4MPT	014636	1	
16	FITTING, WATER LUBE SHUTOFF VALVE	014100	1	
17	FILTER, WATER LUBE	016086	1	
18	FITTING, 5/8" NPT TO 3/8" HOSE BARB	014113	1	
19	TUBING, WATER LUBE 3/8" I.D.	R01885	2,1 m	

4.7 LT40DC Saw Head Decals

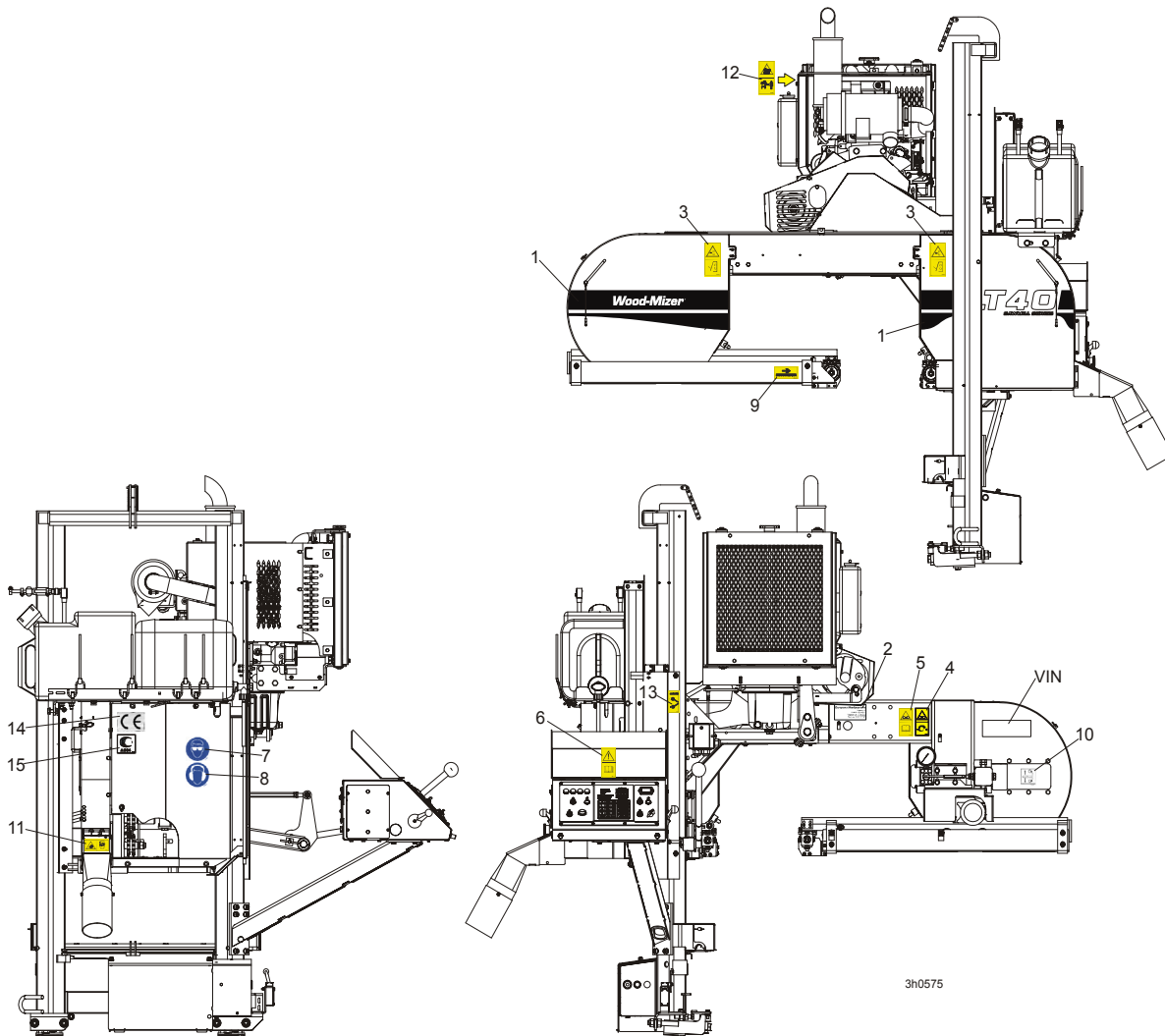

REF	DESCRIPTION (◆ Indicates Parts Available In Assemblies Only)	PART #	QTY.
1	DECAL, LT40 SERIES SAWMILL	092763	1
	PICTOGRAPHIC DECAL KIT, LT40DC	099517	1
2	DECAL, EUROPEAN HEADQUARTERS ADDRESS	015841	1
3	DECAL, SAWMILL COVERS CAUTION	099220	2
4	DECAL, BLADE TENSION (PICTOGRAM)	099219	1
5	DECAL, BLADE TENSION - INSTRUCTIONS (PICTOGRAM)	099223	1
6	DECAL, READ OPERATOR'S MANUAL (PICTOGRAM)	096317	1
7	DECAL, EYE PROTECTION WARNING (PICTOGRAM)	S12004G	1
8	DECAL, EAR PROTECTION WARNING (PICTOGRAM)	S12005G	1
9	DECAL, BLADE MOVEMENT DIRECTION (PICTOGRAM)	096321	1
10	DECAL, BLADE ALIGNMENT	P11789	1
11	DECAL, SAWDUST CHUTE WARNING (PICTOGRAM)	099222	1
12	DECAL, KEEP AWAY - HOT PARTS (PICTOGRAM)	086099	1
13	DECAL, BLADE DRIVE WARNING (PICTOGRAM)	096315	1
14	DECAL, CE CERTIFIED SAWMILL (SMALL)	P85070	1
15	DECAL, RUSSIAN SAFETY CERTIFICATION	099401	1
16	REFLECTOR, 2 DIA RED (MOBILE SAWMILLS ONLY)	P07452	1

4.8 Blade Housing Covers

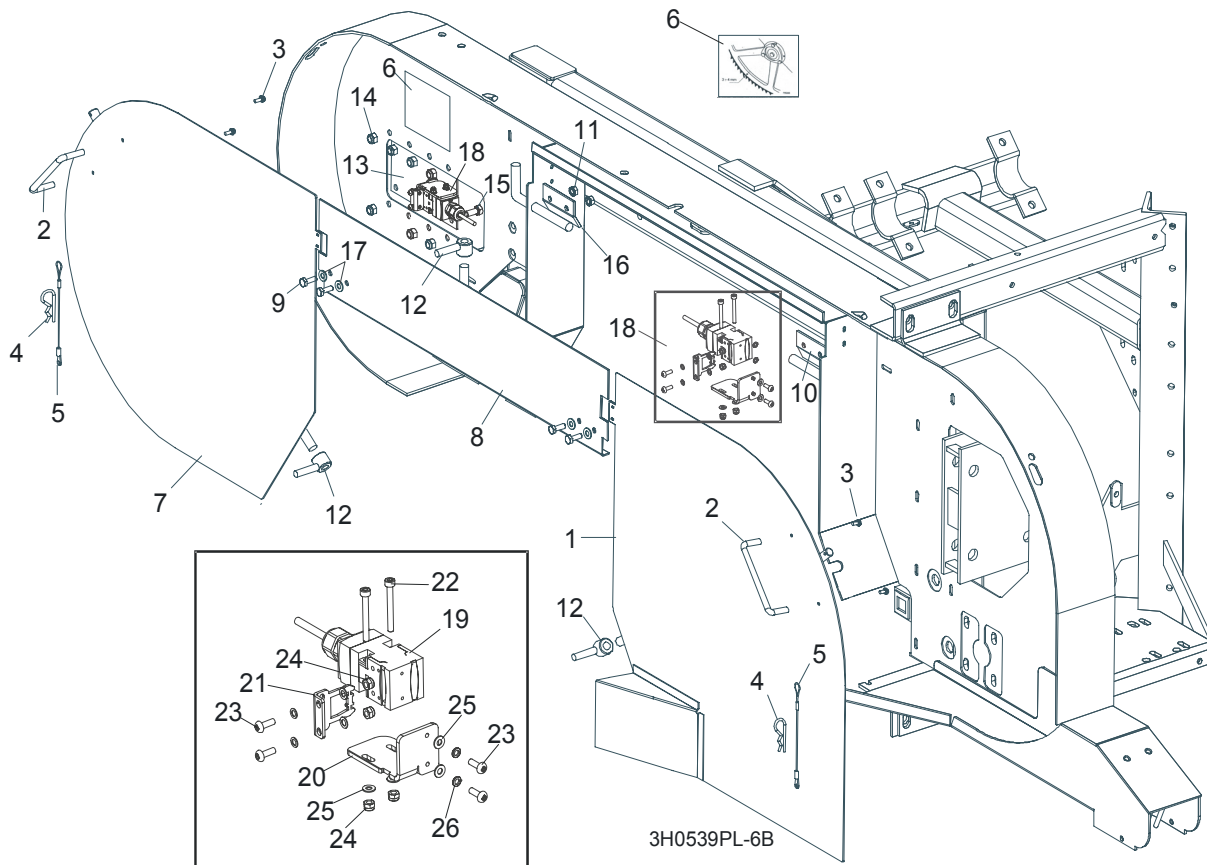

REF	DESCRIPTION (◆ Indicates Parts Available In Assemblies Only)	PART #	QTY.	
	COVER ASSEMBLY, DRIVE SIDE BLADE HOUSING WITH HANDLE	087165	1	
1	Cover Weldment, Drive Side Blade Housing	087159-1	1	◆
2	Handle, Blade Housing Cover	P08065	1	
3	Screw, #8-32 x 3/8"	F05015-8	2	
	Pin Assembly, Cover Retainer	A11881	1	
4	Pin, Safety Retainer	N/A	1	
5	Cable, 3/64" x 6" Lanyard	N/A	1	
6	DECAL, BLADE SETTING	P85066	1	
	COVER, IDLE SIDE BLADE HOUSING WITH HANDLE	086431	1	
7	Cover, Idle Side Blade Housing	086430-1	1	◆
2	Handle, Blade Housing Cover	P08065	1	
3	Screw, #8-32 X 3/8" Self-Tap	F05015-8	2	
	Pin Assembly, Cover Retainer	A11881	1	
4	Pin, Safety Retainer	N/A	1	
5	Cable, 3/64" x 6" Lanyard	N/A	1	
8	COVER, MIDDLE BLADE HOUSING	087326-1	1	
9	BOLT, 1/4-20 X 3/4" HEX HEAD	F05005-1	4	
10	HINGE, MIDDLE BLADE HOUSING COVER	S07522	1	
11	NUT, 1/4-20 SELF-LOCKING HEX	F05010-9	4	
12	NUT, COVER TURN	086365-1	2	

13	PLATE, IDLE BLADE WHEEL GUARD	086230	1	
14	NUT, 5/16-18 HEX NYLON LOCK	F05010-58	6	
15	BOLT, 5/16-18 X 3/4" HEX HEAD GRADE 2	F05006-5	6	
16	HINGE, MIDDLE BLADE HOUSING COVER	085336-1	1	
17	WASHER 6.4 ZINC	F81053-1	4	
18	SWITCH ASSEMBLY, SAFETY SHUT-OFF	094301	2	
19	Safety Switch, AZ17-11ZRK	094232	2	
20	Holder, Safety Switch	094300-1	2	
21	Key, AZ17/170-B5 Safety Switch	094422	2	
22	Bolt, M4 x 35-8.8 Socket Head	F81011-34	4	
23	Screw, M4 x 12-5.8	F81011-43	8	
24	Nut, M4 Hex	F81029-1	8	
25	Washer, M4 Split Lock Zinc	F81051-1	4	
26	Washer, 4.3	F81051-2	8	

4.9 Drive Belt Covers

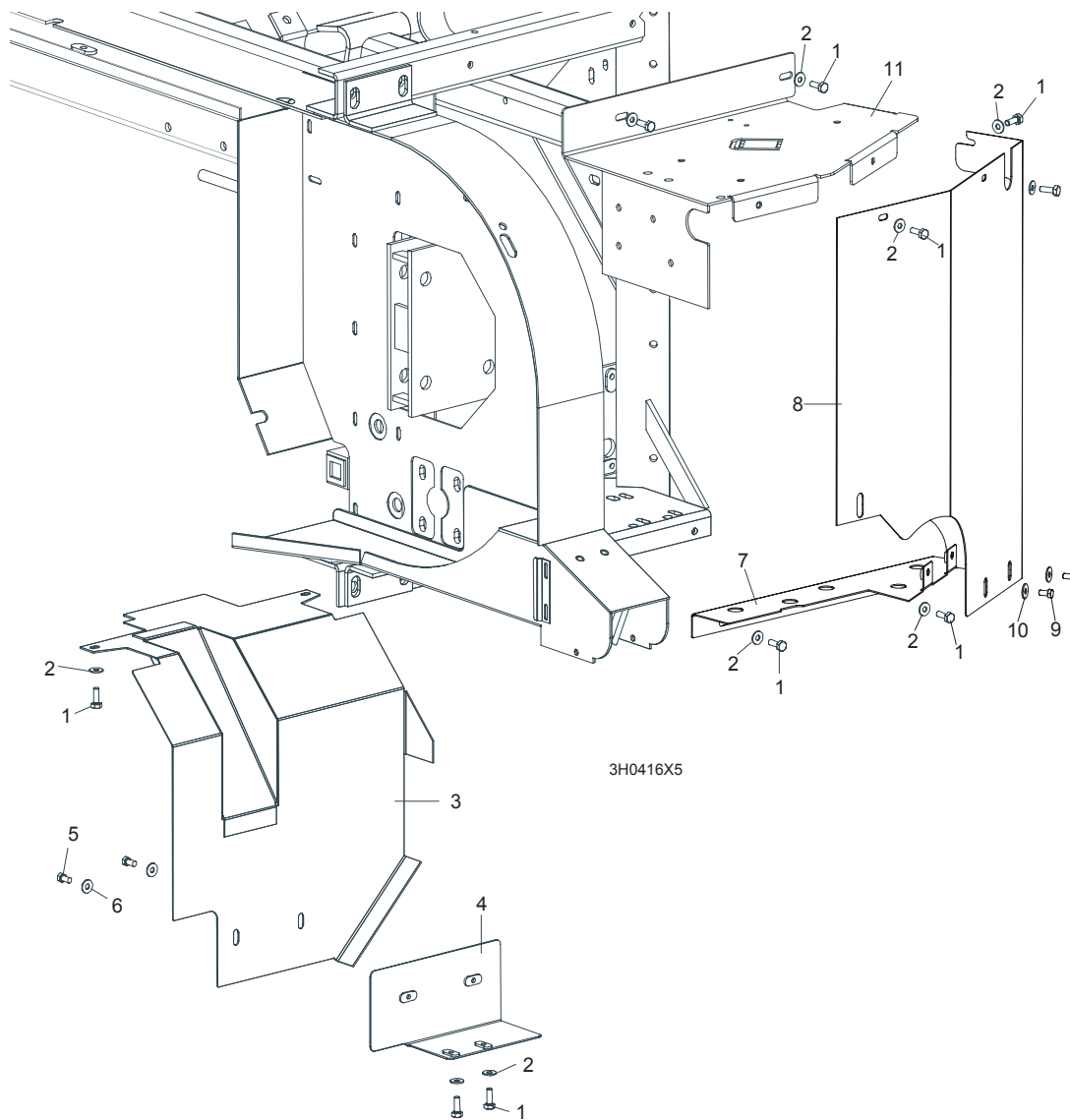

REF	DESCRIPTION (◆ Indicates Parts Available In Assemblies Only)	PART #	QTY.
1	BOLT, M6X12-8.8-ZINC	F81001-7	11
2	WASHER 6,5 ZINC	F81053-11	11
	GUARD ASSEMBLY, CLUTCH LEVER	086290	1
3	Guard Weldment, Manual Clutch	093398-1	1
4	Mount Weldment, Clutch Guard	086275-1	1
5	Bolt, M6X12-8.8 Hex Head Zinc	F81001-7	2
6	Washer, 6.5 Flat Zinc	F81053-11	2
	GUARD ASSEMBLY, DRIVE PULLEY SIDE	093396	1
7	Guard Weldment, Side Up/Down	100474-1	1
8	Guard Weldment, Saw Head Frame Lower	100473-1	1
9	Bolt, M6X12-8.8 Hex Head Zinc	F81001-7	2
10	Washer, 6.5 Flat Zinc	F81053-11	2
11	GUARD, DRIVE PULLEY TOP	087033-1	1

4.10 Sawdust Chute

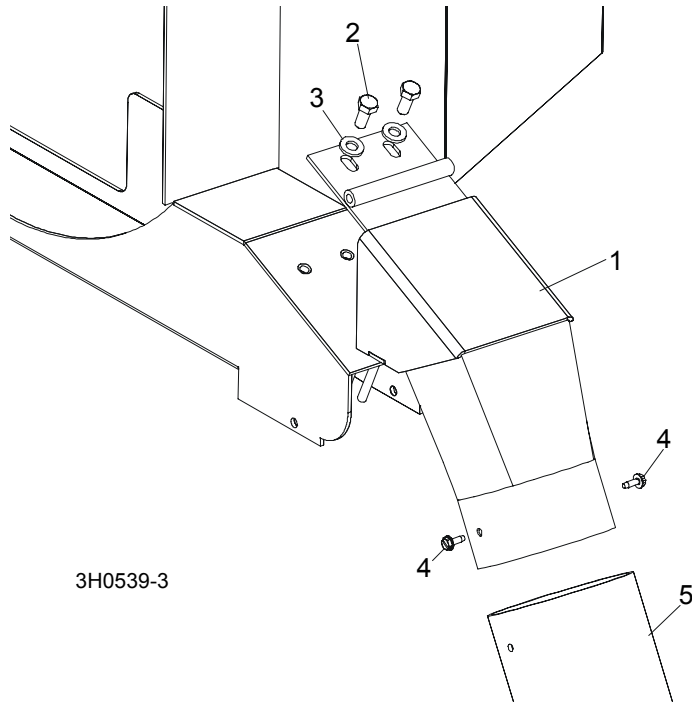

REF	DESCRIPTION (◆ Indicates Parts Available In Assemblies Only)	PART #	QTY.	
1	CHUTE WELDMENT, SAWDUST	100903-1	1	
2	BOLT, M8X20-8.8-B-ZINC HEX HEAD	F81002-20	2	
3	WASHER 8,4-ZINC ROUND	F81054-1	2	
4	BOLT, #10-24 X 1/2" SELF-TAPPING	F05015-7	2	
5	TUBING, 4" I.D. RUBBER	086364	0.6 m	
	STRAP, 20" RUBBER W/HOOK	P11668	1	
	BOLT, 1/4-20 X 1 1/4" HEX HEAD FULL THREAD	F05005-3	1	
	WASHER, 7.4 FLAT	F81056-11	1	
	NUT, 1/4-20 LOCK	F05010-21	1	

SECTION 5 CONTROL & BATTERY BOXES

5.1 Control Assembly, LT40 Series

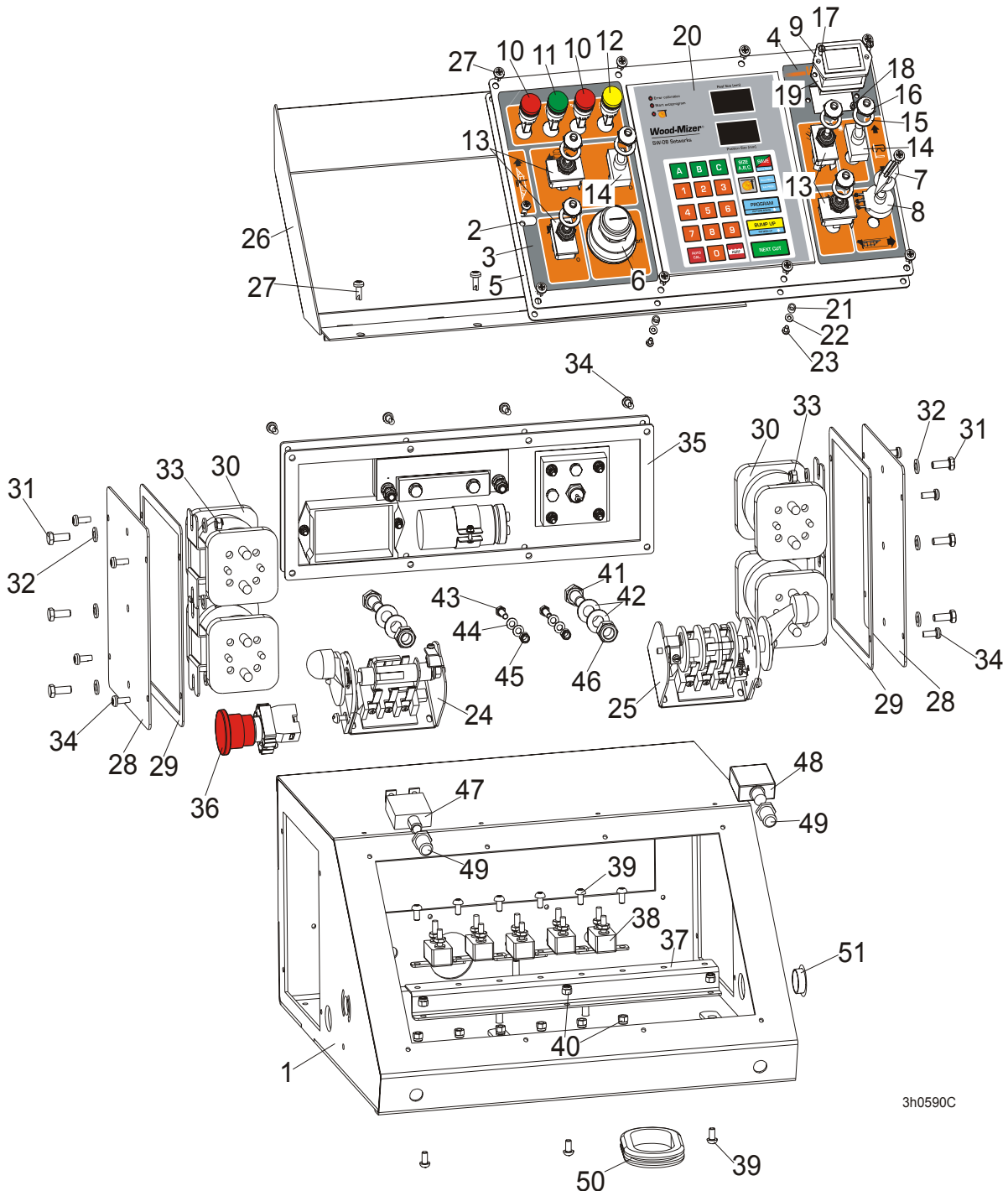

3h0590C

REF	DESCRIPTION (◆ Indicates Parts Available In Assemblies Only)	PART #	QTY.
	CONTROL BOX ASSEMBLY, LT40 DC	098375	1
1	Control Box, LT40	098373-1	1
	Panel, LT40 DC Front Control Complete	098691	1
2	Panel, LT20/40 DC Front Control	100573-1	1
	Panel, LT40 DC Front Control	098376-1 ¹	1

3	Decal, LT40 DC Control Box Left	099595	1	
4	Decal, LT40 DC Control Box Right	099596	1	
5	Gasket, LT20/40 Control Box	097132	1	
6	Switch, Key	P04350	1	
7	Knob, Speed Control	P06257	1	
8	Potentiometer, 1k Feed Rate	E20519	1	
9	Meter, Hour	093166	1	
10	Light, XB6AV4BB Red	091099	2	
11	Light, XB6AV3BB Green	087348	1	
12	Light, XB6AV5BB Yellow	089812	1	
13	Switch, Toggle	024000	4	
14	Switch, SPST On/Off 15A .25 TABS Toggle	P03027	2	
15	Washer, 1/2x3/4x1/16 Nylon	P05251-1	6	
16	Boot, Toggle Switch	P02575	6	
17	Bolt, M3x12-8.8 Zinc	F81000-12	2	
18	Nut, M3-6 Nylon Zinc Lock	F81028-2	2	
19	Gasket, Hour Meter	093346	1	
20	Controller, SW-08 Networks	100570	1	
	Frame, SW08 Networks Rear	100909	1	
21	Spacer, 4.2x6mm Idler	R80671-4	6	
22	Washer, 3.2 Flat Zinc	F81050-2	6	
23	Screw, M3x8-4.8 Zinc	F81000-83	6	
24	Switch, 1992GS Pwr/Feed (Service Package)	E20438	1	
25	Switch, 1992 Up/Down (Service Package)	E20440	1	
26	Cover Weldment, LT20/40 Complete	097135-1	1	
27	Bolt, #10-24x1/2 Ph Pan Hd, Type 23	F05015-17	14	
	Solenoid Assembly, DC Up/Down	086747	1	
	Solenoid Assembly, DC Power Feed	086749	1	
	Cover, Control Box Side Complete	086700	1	
28	Cover, Control Box Side	086699-1	1	
29	Gasket, Control Box Side	015274	1	
30	Solenoid, 200A 12V DPST	015417	2	
31	Bolt, M6x16-5.8-Fe/Zn5 PN-M/82105	F81001-14	3	
32	Washer, M6 Flat Zinc	F81053-1	6	
33	Nut, M6, Hex, Nylon Lock Zinc	F81031-2	3	
34	Bolt, #10-24x1/2 Ph Pan Hd, Type 23	F05015-17	12	
	Panel Assy, Power Feed Control SMT 97+	024412	1	
35	Gasket, Power Feed Control	015278	1	
36	Switch, XB2 BS542 Emergency	086556	1	
	Breaker Assembly, Sawmill Control Circuit	086746	1	
37	Rail, Circuit Breaker	015310	1	◆
38	Breaker, 15A Manual Reset	E20430	5	◆
39	Screw, H M5x10 8.8 Zinc	F81000-13	9	
40	Nut, M5-8 Zinc	F81030-2	9	
41	Bolt, M10x20mm, Hex Head, Gr 5.8 Zinc	F81003-1	2	
42	Washer, M10 Flat Zinc	F81055-1	4	
43	Nut, M10 Nylon Hex Zinc Lock	F81033-1	2	
44	Bolt, M5x16-8.8 Zinc	F81000-20	2	
45	Washer, M5 Flat Zinc	F81052-1	4	

46	Nut, M5-8 Zinc	F81030-2	2	
47	Breaker, 70A Manual Reset Panel Mount	015527	1	
48	Breaker, 50A Manual Reset Panel Mount	021256	1	
49	Boot, Circuit Breaker	021253	2	
50	Grommet, Rubber	087065	1	
51	Cap, SR1086 22.2 Dia. Hole	093544	1	

¹ Use in African version only.

5.2 Drum Switches

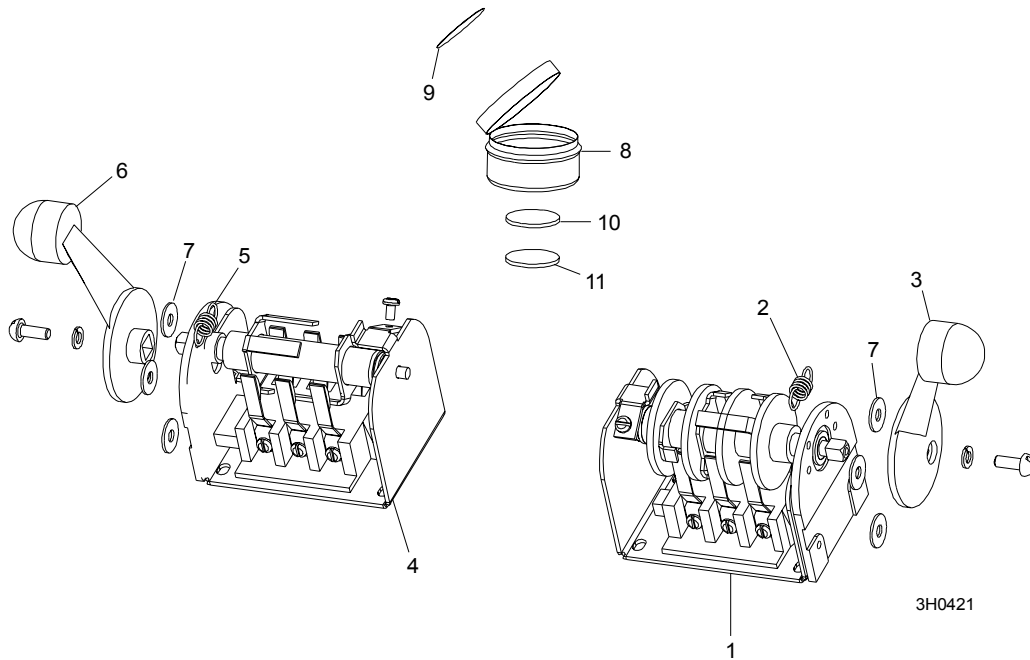

REF	DESCRIPTION (◆ Indicates Parts Available In Assemblies Only)	PART #	QTY.	
	SWITCH ASSEMBLY, UP/DOWN DRUM	E20440	1	
1	Switch, S12 Bulk Drum	E20440-B	1	◆
2	Spring, Drum Switch	P12570	1	
3	Handle, Drum Switch Replacement	P12500	1	
	SWITCH ASSEMBLY, POWER FEED DRUM	E20438	1	
4	Switch, S10 Bulk Drum	E20438-B	1	◆
5	Spring, Drum Switch	P12570	1	
6	Handle, Drum Switch Replacement	P12500	1	
7	WASHER, #8 SAE FLAT	F05011-41	6	
	CUP ASSEMBLY, DRUM SWITCH GREASE	A20463	1	
8	Cup, Plastic Container	P20464	1	◆
9	Decal, Grease Cup Label	P20467	1	
10	Pad, Velcro Loop	P20466	1	◆
11	Pad, Velcro Hook	P20465	1	◆
	Grease, High Temp Drum Switch	P20468	.011m	◆

5.3 Circuit Breakers

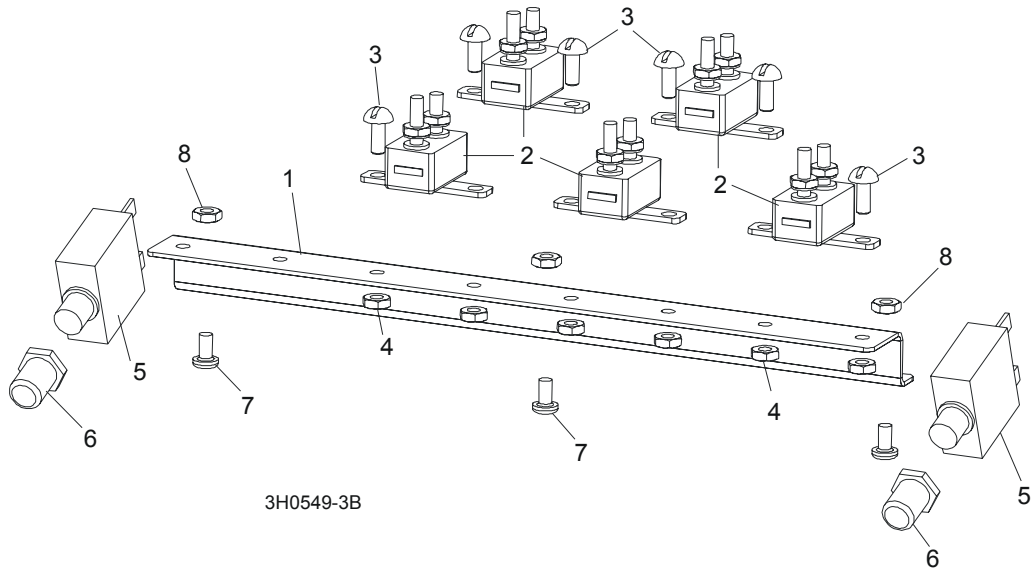

REF	DESCRIPTION (◆ Indicates Parts Available In Assemblies Only)	PART #	QTY.
	BREAKER ASSEMBLY, SAWMILL CONTROL CIRCUIT	015621	1
1	Rail, Circuit Breaker	015310	1
2	Breaker, 15 Amp Manual Reset	E20430	5
3	Screw, H M5x10 8.8 Slotted Head Zinc	F81000-13	6
4	Nut, M5-8 Hex Self-Locking Zinc	F81030-2	6
5	BREAKER, 70 AMP MANUAL RESET PANEL MOUNT	015527	2
6	BOOT, CIRCUIT BREAKER	021253	2
7	BOLT, M5X12-5.8 ZINC	F81000-5	3
8	NUT, M5-8 SELF LOCKING ZINC	F81030-2	3

5.4 Solenoid Assemblies

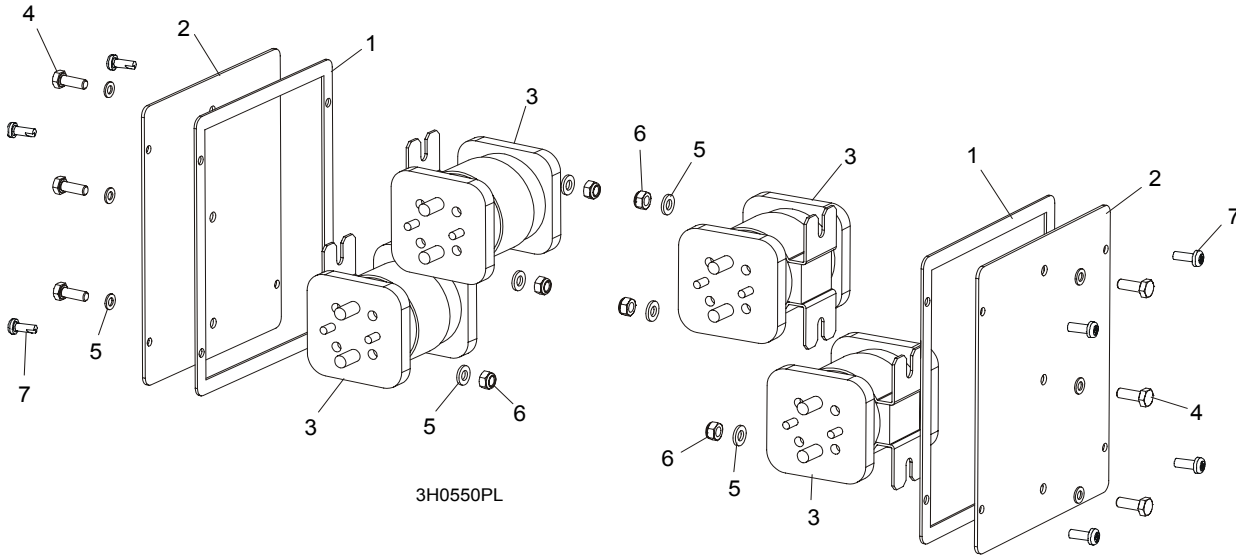

REF	DESCRIPTION (◆ Indicates Parts Available In Assemblies Only)	PART #	QTY.
1	GASKET, SIDE PANEL CONTROL	015274	2
2	PANEL WELDMENT, SIDE	086699-1	2
3	SOLENOID, 200A 12V DPST	015417	4
4	BOLT, M6 X 16-5.8 HEX HEAD	F81001-14	6
5	WASHER, 6.4 FLAT	F81053-1	12
6	NUT, M6-8 HEX	F81031-2	6
	DIODE ASSEMBLY, SOLENOID COIL CHASSIS GND	087496	4
7	SCREW, #10-24 X 1/2" PAN HEAD	F05015-17	8

5.5 Battery Box Assembly, LT40 Series

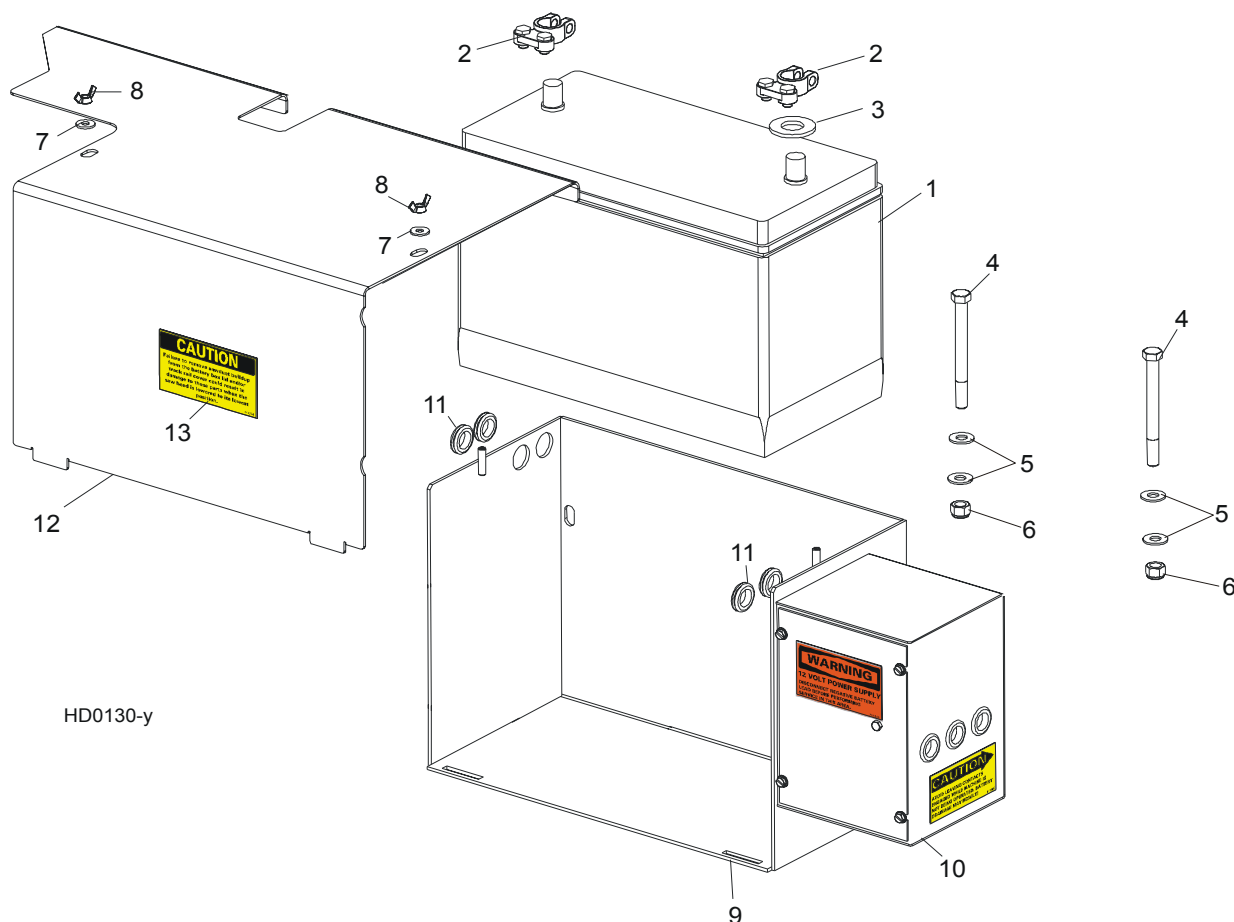

HD0130-y

REF	DESCRIPTION (◆ Indicates Parts Available In Assemblies Only)	PART NUMBER	QTY.
1	BATTERY, "BANNER" 12V100AH #95751	088323	1
	BOX ASSEMBLY, LT40SHD/LT40MHD BATTERY	086509	1
2	Terminal, Battery	P05085	2
3	Washer, Battery Terminal	P12161	1
4	Bolt, 3/8-16 X 4" Hex Head Grade 2	F05007-4	2
5	Washer, 10.5 Flat	F81055-1	4
6	Nut, 3/8" Hex Nylon Lock	F05010-10	2
7	Washer, 7.4 Flat	F81056-11	2
8	Nut, 1/4-20 Wing	F05010-13	2
9	Box Weldment, Battery	086265-1	1
10	Fuse Box Parts (See Section 5.6)		
11	Grommet, 5/8" Rubber Wire	P11764	5
	Contact Assembly, Hydraulic Positive (See Section 9.4)	085968	1
12	LID WELDMENT, BATTERY BOX SUPER	086277-1	1
13	DECAL, BATTERY BOX LID CAUTION	014774	1

5.6 Fuse Box Assembly, LT40 Series

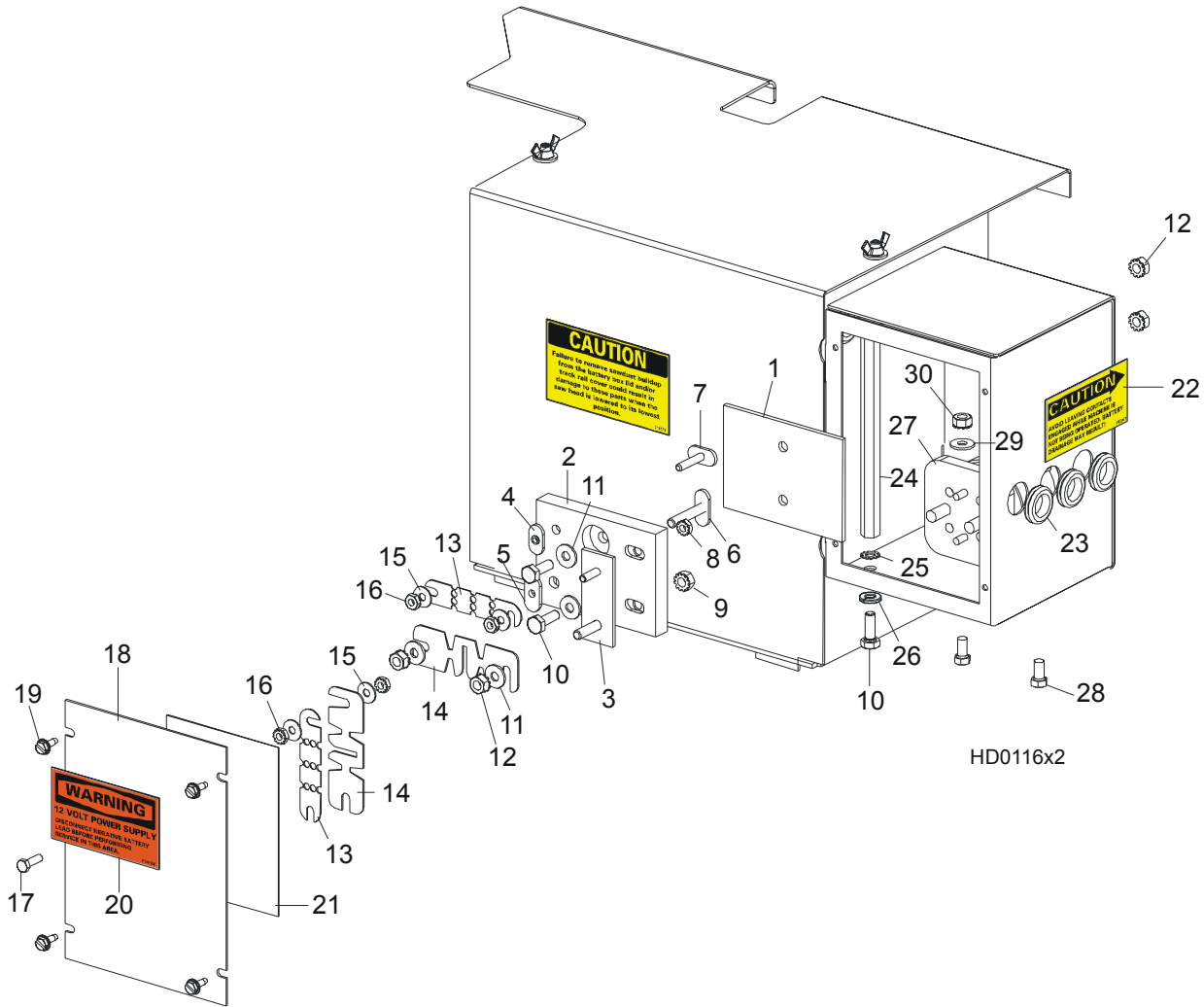

REF	DESCRIPTION (◆ Indicates Parts Available In Assemblies Only)	PART NUMBER	QTY.	
1	PAD, FUSE BOX INSULATOR	015287	1	
	FUSE BLOCK ASSEMBLY	017665	1	
2	Block, Fuse Mount	015286	1	◆
3	Buss Weldment, Fuse Mount	015289	1	◆
4	Nut, #10-24 Cadmium Plated Weld	S12391	1	◆
5	Nut, 1/4-20 Cadmium Plated Weld	S12392	1	◆
6	Stud Weldment, 1/4-20 Fuse	W12389	1	◆
7	Stud Weldment, #10-24 Fuse	W12390	1	◆
8	Nut, #10-24 Self-Locking Hex	F05010-14	1	◆
9	Nut, 1/4-20 Self-Locking Hex	F05010-9	1	◆
10	BOLT, 1/4-20 X 3/4" HEX HEAD FULL THREAD	F05005-1	3	
11	WASHER, 7.4 FLAT	F81056-11	4	
12	NUT, 1/4-20 HEX SELF-LOCKING	F05010-9	4	
13	FUSE LINK, 12 VOLT 150 AMP	023361	2	
14	FUSE LINK, 12 VOLT 225 AMP	P11550	2	
15	WASHER, 5.3 FLAT	F81052-1	4	

16	NUT, #10-24 HEX SELF-LOCKING	F05010-14	4	
17	SCREW, #10-24 X 5/8" HEX HEAD	F05004-18	1	
18	COVER, FUSE BOX	086272-1	1	
19	SCREW, #10-24 X 1/2" SELF-TAPPING	F05015-7	4	
20	DECAL, 12 VOLT WARNING	P10364	1	
21	DECAL, '97 SUPER HYDRAULIC	015372	1	
22	DECAL, HYDRAULIC CONTACT CAUTION	P12960	1	
23	GROMMET, 5/8" RUBBER WIRE	P11764	3	
24	TERMINAL, EXTENDED HEX STUD	015517	1	
25	WASHER, 6.4 EXTERIOR STAR	F81053-2	1	
26	WASHER, 6.1 SPLIT LOCK	F81053-3	1	
27	SOLENOID, 200A 12V SPST CONT. DUTY	015470	1	
28	BOLT, 1/4-20 X 1/2" HEX HEAD	F05005-15	2	
29	WASHER, 7.4 FLAT	F81056-11	2	
30	NUT, 1/4-20 SELF-LOCKING HEX	F05010-9	2	

SECTION 6 UP/DOWN SYSTEM

6.1 Saw Head V-Brace Mount

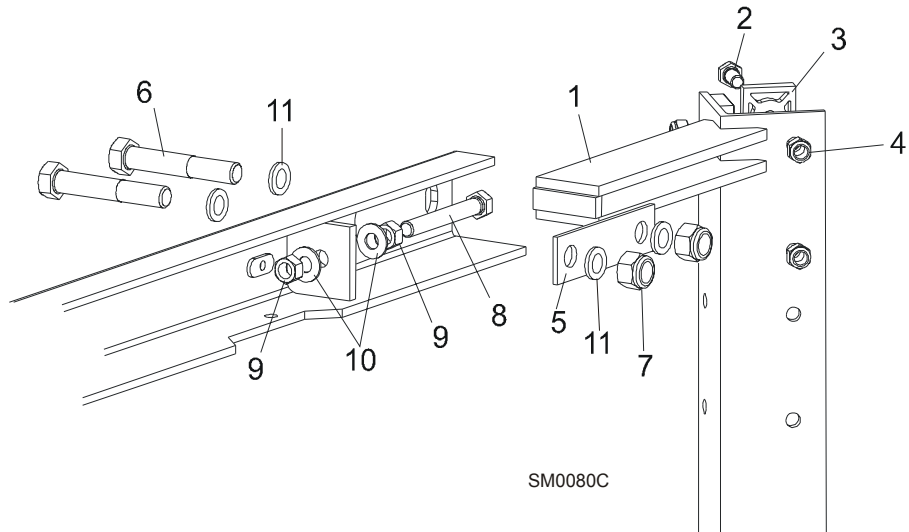

REF	DESCRIPTION (◆ Indicates Parts Available In Assemblies Only)	PART #	QTY.
1	V-BRACE, SAW HEAD MOUNT	087125	1
2	BOLT, M8X20-5.8-ZINC HEX HEAD	F81002-4	10
	BOLT, M8X25-8.8-B-ZINC HEX HEAD	F81002-5	2
3	PAD, PLASTIC SLIDE	M04096	6
4	NUT, M8-8-B-ZINC HEX NYLON LOCK	F81032-2	12
5	PLATE, V-BRACE WASHER	091247	2
6	BOLT, M12X75-8.8-ZINC	F81004-21	4
7	NUT, M12 - 8 NYLON LOCK	F81034-2	4
8	BOLT, M10X70-8.8-ZINC HEX HEAD	F81003-20	2
9	NUT, M10-8-B-ZINC HEX	F81033-3	4
10	WASHER, 10.5 FLAT	F81055-1	4
11	WASHER, 13 SPLIT LOCK ZINC	F81056-1	8

6.2 Blade Height Scale

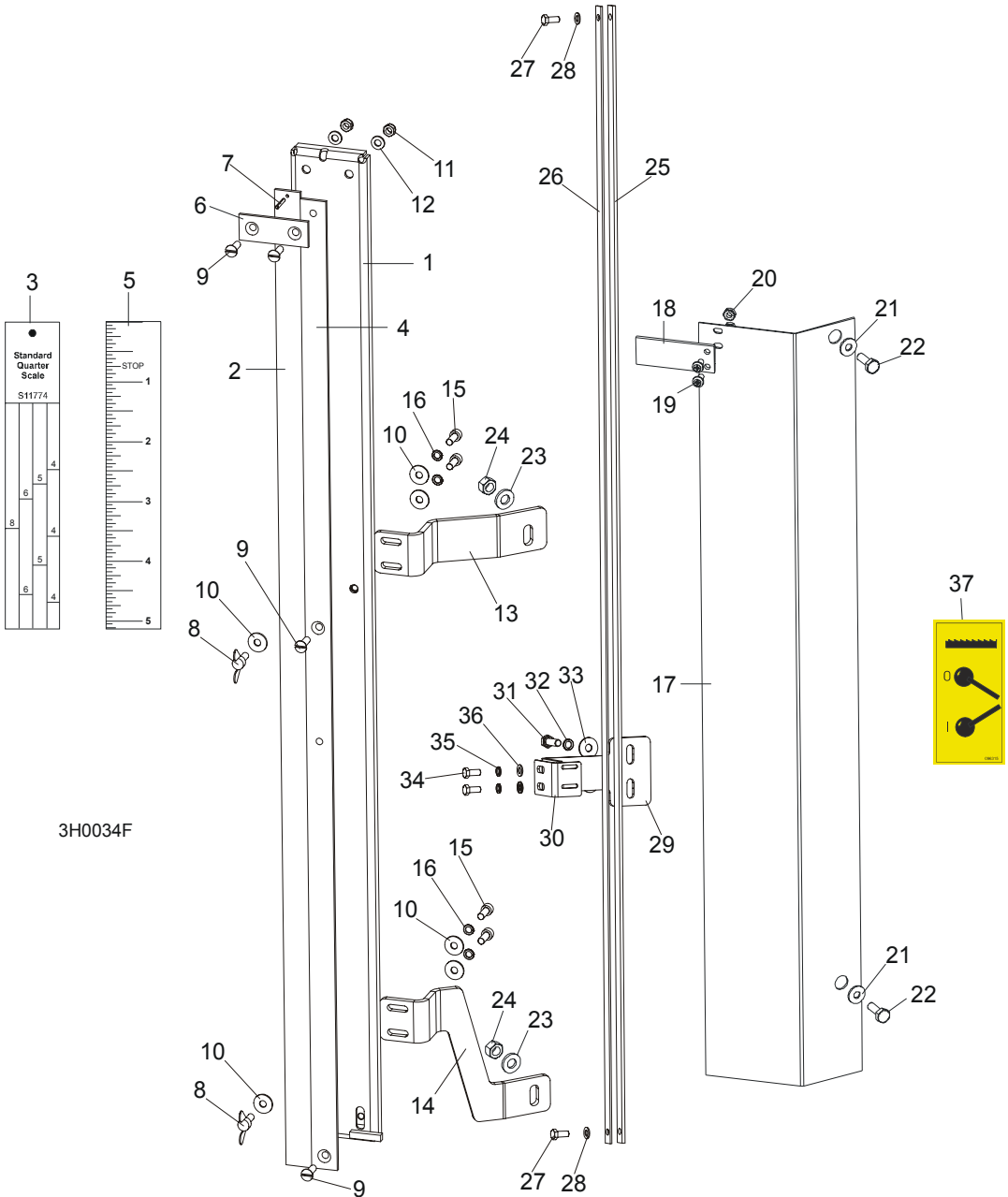

3H0034F

REF	DESCRIPTION (◆ Indicates Parts Available In Assemblies Only)	PART #	QTY.
	SCALE, BLADE HEIGHT W/SCANNER	098882	1
1	Bracket, Scale Mounting	098890-1	1
2	Scale, 35" Quarter	093342	1
3	Decal, 35" Standard Quarter Scale	090716	1
	Decal, 35" Grade Hardwood Quarter Scale	090717	1
4	Scale, 35" Inch	093341	1
5	Decal, 35" Inch	090709	1
6	Strap, Scale Hold-Down	093134	1
7	Pin, 3x20 Roll	F81044-5	1
8	Screw, M6x16 Wing	F81001-16	2

9	Screw, M6x20- 4.8-B	F81001-31	4	
10	Washer, 6.5 Flat	F81053-11	7	
11	Nut, M6, Hex, Nylon Lock Zinc	F81031-2	2	
12	Washer, M6, Flat, Zinc	F81053-1	2	
13	Bracket, Scale Upper	098880-1	1	
14	Bracket, Scale Lower	098881-1	1	
15	Bolt, M6x16-8.8 Socket Head	F81001-21	4	
16	Washer, M6 Split Lock Zinc	F81053-3	4	
	Pointer Assembly, Fixed Scale	A12023	1	
17	Bracket, Fixed Scale Pointer Mount	087044-1	1	◆
18	Indicator, Blade Height Scale	094821	1	
19	Screw, M4x12 -5,8-B- Fe/Zn5	F81011-43	2	
20	Nut, M4-B Fe/Zn5	F81029-1	2	
21	Washer, 6.5 Flat	F81053-11	2	
22	Bolt, M6x12-8.8-Zinc	F81001-7	2	
23	Washer, 8.4 Flat	F81054-1	2	
24	Nut, M8-8-B Hex Lock	F81032-2	2	
	MAGNETIC STRIP ASSY	097774	1	
	Bar with Magnetic Strip	098173-1	1	
25	Magnetic Strip MB320 (1m)	096014-1	1	
26	Bar, Magnetic Strip	098173	1	
27	Bolt, M5 X 12-5.8-Fe/Zn5	F81000-5	2	
28	Washer, M5, Flat zinc	F81052-1	2	
	BRACKET, SENSOR COMPLETE	100620	1	
29	Bracket, Sensor	100599-1	1	
30	Bracket, Sensor	100619-1	1	
31	Bolt, M6x20-8.8 Hex Head Full Thread Zinc	F81001-2	2	
32	Washer, Z6.1 Split Lock Zinc	F81053-3	2	
33	Washer, 6.5 Flat Zinc	F81053-11	2	
34	Bolt, M5 X 12-5.8-Fe/Zn5, PN-M/82105	F81000-5	2	
35	Washer, 5.1 Split Lock Zinc	F81052-2	2	
36	Washer, 5.3 Flat Zinc	F81052-1	2	
	DECAL KIT, METRIC SCALE	K12064	1	
	Decal, Metric	S11711	1	
	Decal, Metric 16-40mm	P12040-1	1	
	Decal, Metric 45-63mm	P12040-2	1	
37	DECAL, CLUTCH HANDLE OPERATION, PICTOGRAM	096315	1	

6.3 Up/Down Chain & Sprockets

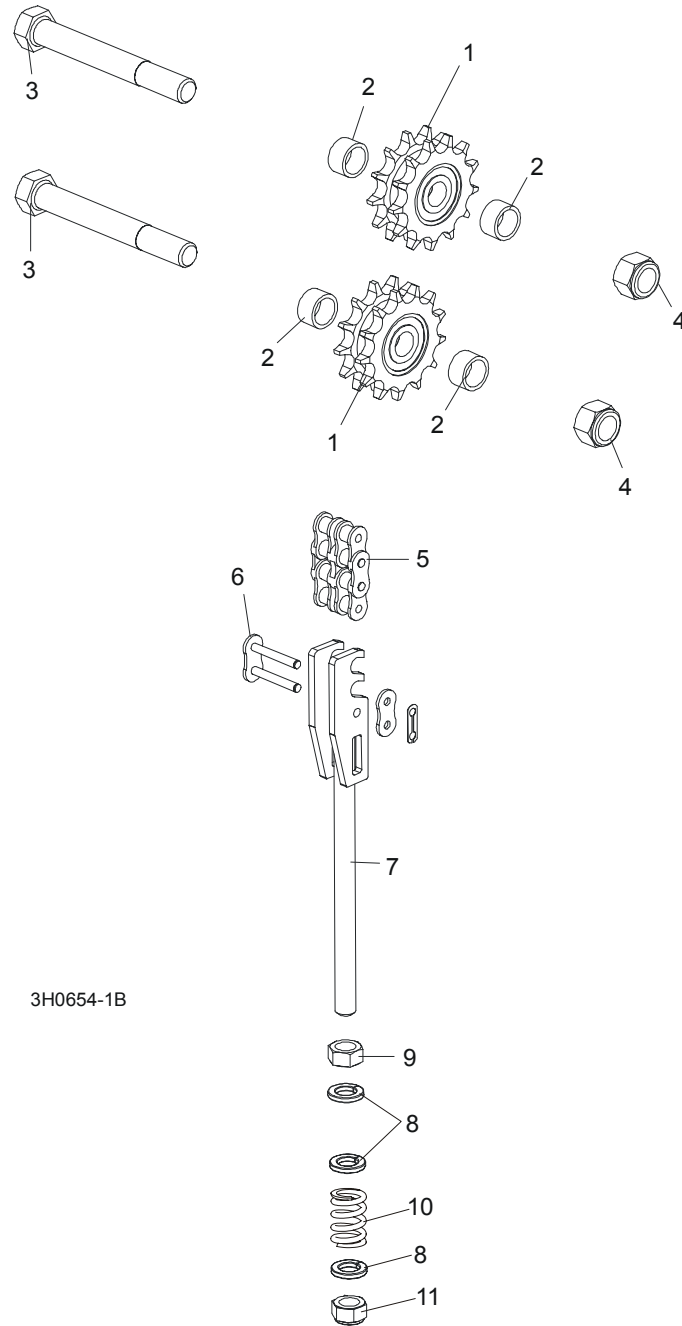

REF	DESCRIPTION (◆ Indicates Parts Available In Assemblies Only)	PART #	QTY.
	SPROCKET KIT, UP/DOWN IDLER #50-2	016020	1
1	Sprocket, Up/Down Idler '98	016019	2
2	Washer, Sprocket Spacer	095927-1	4
	Instruction Sheet, Up/Down Idler Retrofit	016020-541	1
3	BOLT, 5/8-11 X 5" HEX HEAD GRADE 2	F05009-6	2
4	NUT, 5/8-11 HEX NYLON LOCK	F05010-34	2
5	CHAIN, #50-2 X 75.625" UP/DOWN	015259	1
6	LINK, #50-2 MASTER	015258	2

	TENSIONER ASSEMBLY, UP/DOWN CHAIN	094283	1	
7	Bracket, Up/Down Chain Tensioner	094281-1	1	◆
8	Washer, M12, Flat, Zinc	F81056-1	3	
9	Nut, M12-8-B Hex	F81034-1	1	
10	Spring, 14x30x3.2	090797	1	
11	Nut, M12, Hexagon, Nylon, Zinc, Lock	F81034-2	1	

6.4 Up/Down Motor Assembly, LT40 Series

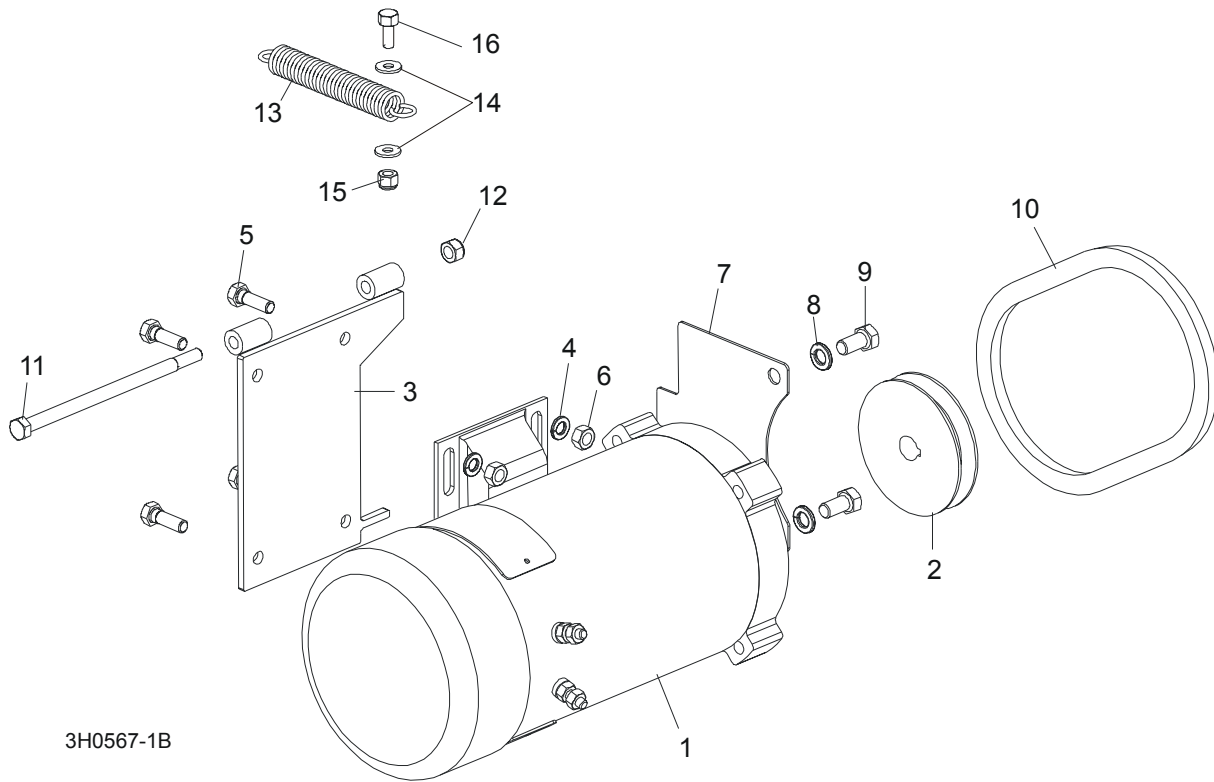

3H0567-1B

REF	DESCRIPTION (◆ Indicates Parts Available In Assemblies Only)	PART #	QTY.
	UP/DOWN MOTOR ASSEMBLY	092818	1
1	Motor, 3/4 HP Electric	015174	1
	Brush Kit, Power Feed Motor (Includes 2 Brushes and 2 Springs)	024167	1
	Fan, 3/4 HP Leeson Motor Replacement	016087	1
2	Pulley, AK28 x 5/8"	033852	1
3	Bracket Wldmt, Up/Down Motor	095738-1	1
4	Washer, M8, Flat, Zinc	F81054-1	4
5	Bolt, M8x20mm, Hex Head, Gr 5.8 Zinc	F81002-4	4
6	Nut, M8, Hexagon, Nylon Lock Zinc	F81032-2	4
7	Guard, Up/Down Sprocket	095739-1	1
8	Washer, 10.2 Split Lock	F81055-2	2
9	Bolt, 3/8-16 x 3/4" Hex Head	F05007-27	2
10	BELT, 4L245	038459	1
11	BOLT, M8X160-8.8-B ZINC	F81002-22	1
12	NUT, M8-8-B NYLON LOCK HEX ZINC	F81032-2	1
13	SPRING, .75" X 5" X .095" EXTENSION	015569	1
14	WASHER, 6.5 FLAT ZINC	F81053-11	2
15	NUT, M6-8-B NYLON LOCK HEX ZINC	F81031-2	2
16	BOLT, M6x25-8.8 ZINC	F81001-20	1

6.5 Up/Down Drive Assembly, LT40 Series

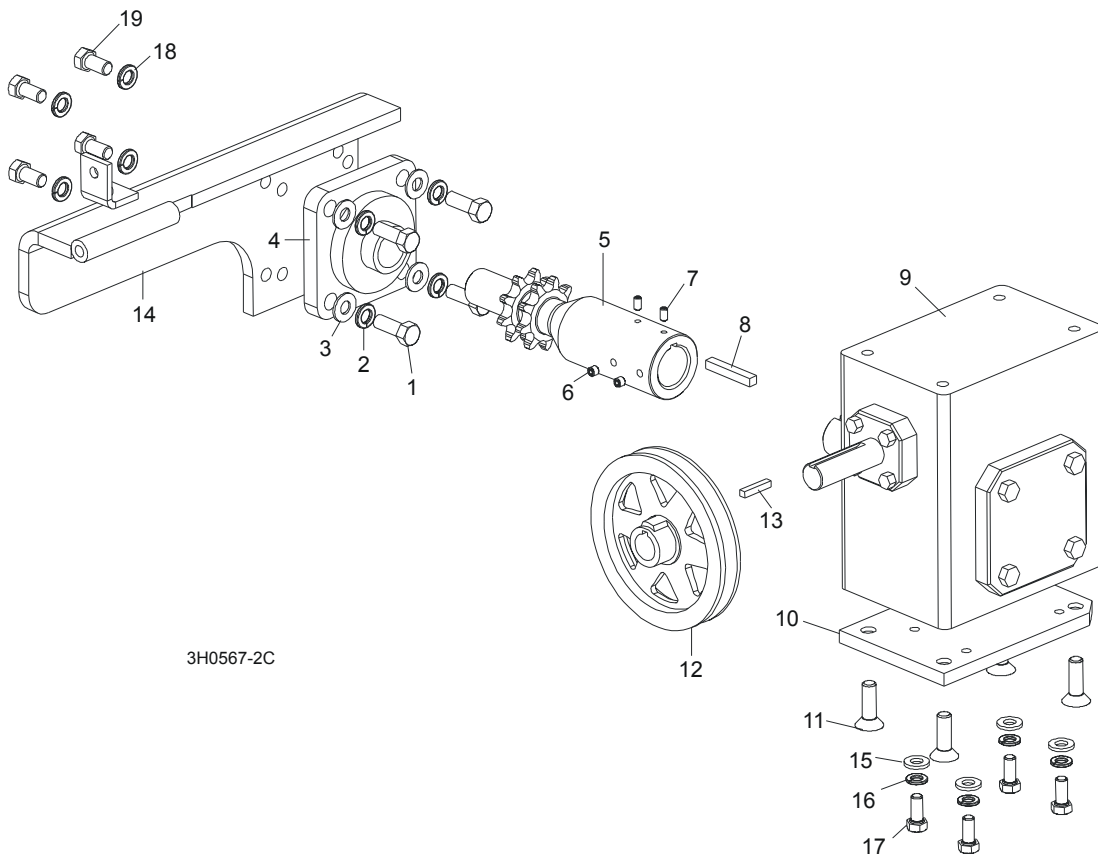

REF	DESCRIPTION (◆ Indicates Parts Available In Assemblies Only)	PART #	QTY.
	UP/DOWN DRIVE ASSEMBLY	092817	1
1	Bolt, 3/8-16 x 1" Hex Head	F05007-7	4
2	Washer, 10.2 Split Lock	F81055-2	4
3	Washer, 10.5 Flat	F81055-1	4
4	Bearing, Flanged Up/Down	014090	1
5	Shaft, Up/Down Sprocket	092816-1	1
6	Screw, M8 x 8-33H	F81014-1	2
7	Screw, M8 x 8-33H	F81014-1	2
8	Key, 1/4" Square x 1 11/16" Long	S04124	1
9	Reducer, Gear Box	014074	1
10	Plate, Gear Box Spacer	095894-1	1
11	Bolt, 3/8-16 x 1" Flat Socket Head	F05007-110	4
12	Pulley, Up/Down	015256	1
13	Key, 3/16" Square x 1" Long	S31027	1
14	Bracket Wldmt, Up/Down Bearing	095893-1	1
15	WASHER, 8.4 FLAT	F81054-1	8
16	WASHER, 8.2 SPLIT LOCK	F81054-4	4
17	BOLT, 5/16-18 X 1" HEX HEAD	F05006-5	4
18	WASHER, 10.5 SPLIT LOCK	F81055-1	4
19	BOLT, 3/8-16 X 3/4" HEX HEAD	F05007-27	4
	OIL, 8 OZ. MOBIL SHC634 BOTTLED SYNTHETIC GEAR	L04869-4	1

SECTION 7 POWER FEED & TRACK ROLLERS

7.1 Upper Track Rollers And Wipers

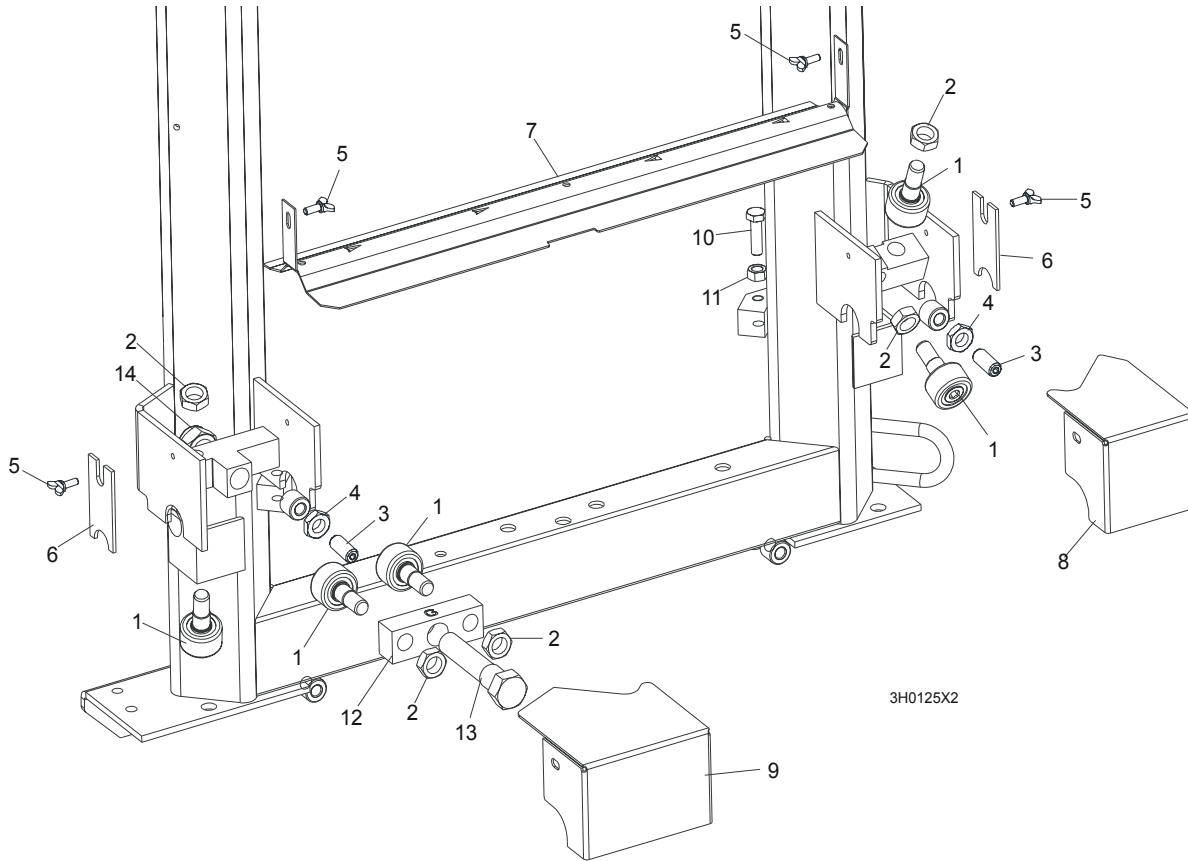

REF	DESCRIPTION (◆ Indicates Parts Available In Assemblies Only)	PART #	QTY.
1	ROLLER, TRACK CAM BEARING (MCGILL)	012797	5
2	NUT, 5/8-18 HEX JAM	F05010-11	5
3	SCREW, M12 X 30 OVAL POINT SET	F81004-14	2
4	NUT, M12-8-B HEX JAM	F81034-1	2
5	SCREW, M6 X 16 THUMB	F81001-16	4
6	WIPER, PLASTIC TRACK	M04113	2
7	COVER, LT40/70 MIDDLE TRACK - SERVICE	092868-S	1
	Cover, LT40/70 Middle Track Ptd	092868-1	1
	Strip, 3/16 X 2 X 23 Felt	S09915	1
8	HOUSING, UPPER TRACK ROLLER REAR	086913-1	1
9	HOUSING, UPPER TRACK ROLLER FRONT	086914-1	1
10	BOLT, M10 X 35-8.8 HEX HEAD	F81003-17	2
11	NUT, M10-8 HEX JAM	F81033-3	2
12	BRACKET, UPPER TRACK ROLLER	086859-1	1
13	BOLT, HEX HEAD	086911	1
14	NUT, M20-8 HEX	F81037-2	1

7.2 Power Feed Assembly,

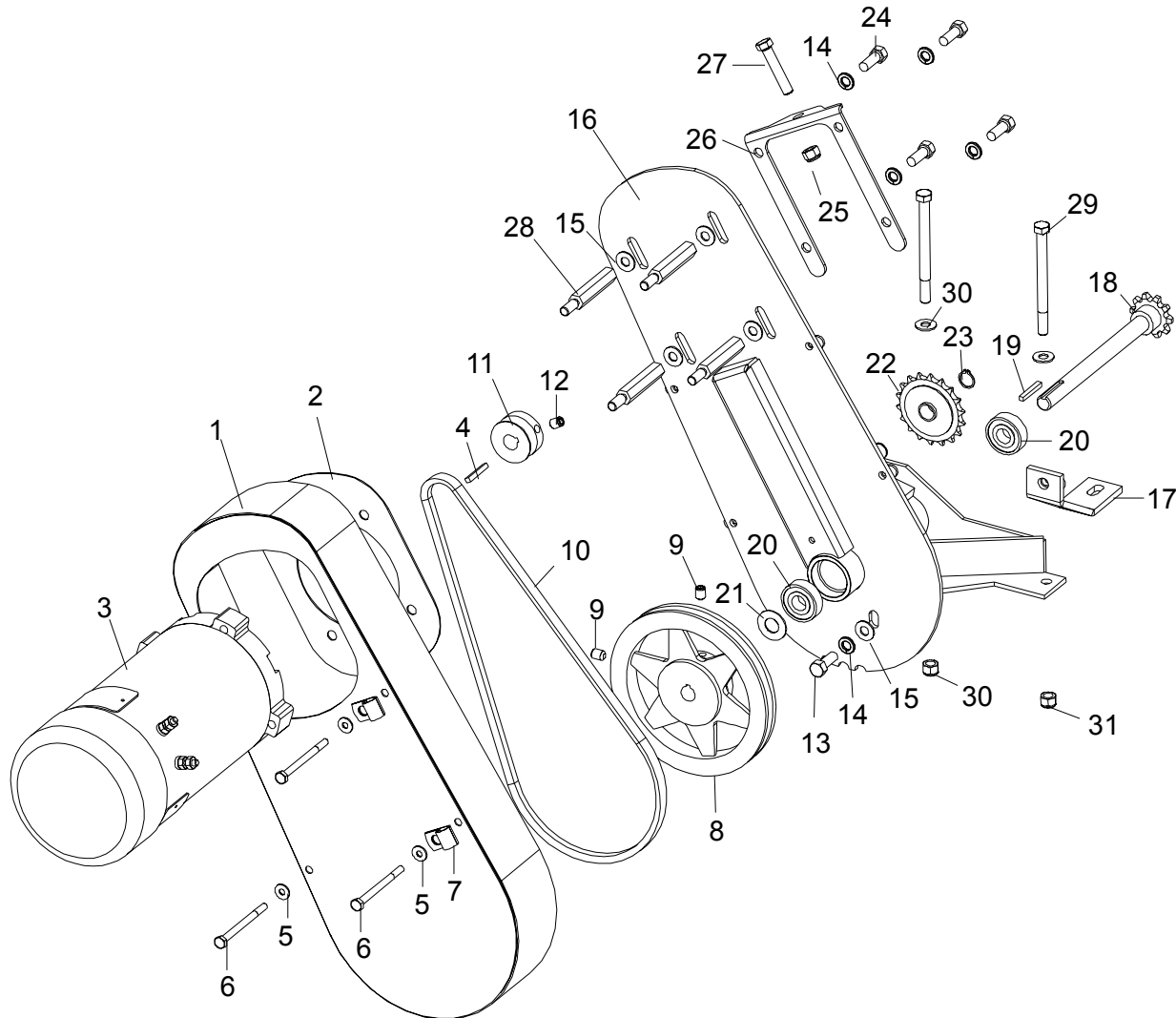

3H0619-2

REF	DESCRIPTION (◆ Indicates Parts Available In Assemblies Only)	PART #	QTY.
	POWER FEED ASSEMBLY	015125	1
1	Cover Weldment, Top Power Feed	015126	1
2	Plate, Power Feed Motor	015133	1
3	Motor, 3/4HP Power Feed Painted	024169	1
	Brush Kit, Leeson 3/4HP Motor (Includes 2 Brushes and 2 Springs)	024167	1
	Fan, 3/4 HP Leeson Motor Replacement	016087	1
4	Key, 3/16" Square x 1 3/8" Long	016109	1
5	Washer, 6.5 Flat	F81053-11	4
6	Bolt, M6x80 Hex Head Zinc	F81001-61	4
7	Clamp, 1/2" EMT Coated	P07584	2
8	Sheave, AK71 x 5/8" Power Feed (200ft./min.)	016088	1
9	Screw, 5/16-18 x 3/4" Cup Point Set	F05006-32	2

10	Belt, AX36 (200ft./min.)	016083	1	
11	Sheave, 1 3/4" Feed Motor	015135	1	
12	Screw, 3/8"-16 x 1/2" Cup Point Set	F05007-12	1	
13	Bolt, M10x25-8.8 Hex Head Zinc	F81003-11	1	
14	Washer, 10.2 Split Lock	F81055-2	5	
15	Washer, 10.5 Flat	F81055-1	5	
16	Bracket, Power Feed Mount	015162-1	1	
17	Brace Weldment, Power Feed Mounting	086554-1	1	
	Shaft Assembly, Power Feed with Key	016066	1	
18	Shaft Weldment, Power Feed	015129	1	◆
19	Key, 3/16" Square x 1 3/8" Long	016108	1	
20	Bearing, 6203 2RSP6-5/8 CX	095087	2	
21	Washer, 5/8" x 15/16" x .094" Nylon	F05011-19	1	
22	Sprocket, 40 Idler 18T 5/8" ID	P04333	1	
23	Ring, Z15 Outer Retaining	F81090-2	1	
24	Bolt, 3/8-16 x 3/4" Hex Head	F05007-27	4	
25	Nut, 3/8-16 Hex Nylon Lock	F05010-10	1	
26	Plate, Belt Tensioner	015134	1	
27	Bolt, 3/8-16 x 2" Full Thread Hex Head	F05007-16	1	
28	Spacer, Power Feed Motor	015136	4	
29	BOLT, 3/8-16 X 4 1/2" HEX HEAD	F05007-35	2	
30	WASHER, 10.5 FLAT	F81055-1	4	
31	NUT, 3/8-16 HEX NYLON LOCK	F05010-10	2	

7.3 Feed Chain/Stop, LT40 Series

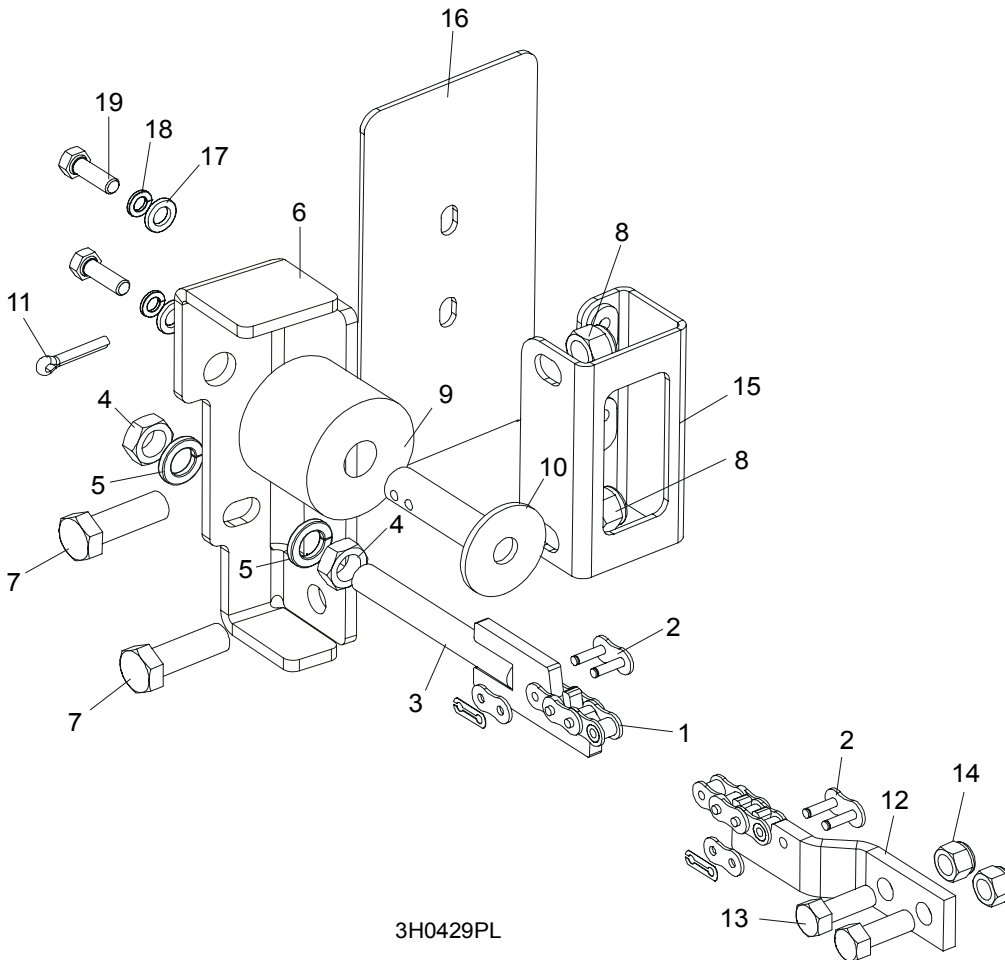

3H0429PL

REF	DESCRIPTION (◆ Indicates Parts Available In Assemblies Only)	PART #	QTY.
	CHAIN KIT, LT40 S FEED	K10408	1
	CHAIN KIT, LT40 M FEED	K10410	1
1	Chain, #40 X 215" LT40S Feed	014744	1
	Chain, #40 X 267.5" LT40M Feed	014475	1
2	Link, #40 Master	P04200	2
3	Tensioner Weldment, Power Feed Chain	086818-1	1
4	Nut, M12-5 Hex Jam	F81034-4	2
5	Washer, 12.2 Split Lock	F81056-2	2
6	BRACKET, FEED CHAIN REAR MOUNT	087628-1	1
7	BOLT, M12 X 40 8.8 HEX HEAD GRADE 5	F81004-4	2
8	NUT, M12-8 HEX NYLON LOCK	F81034-2	2
	STOP KIT, RUBBER CARRIAGE	K09630	2
9	Stop, Rubber Carriage	P12165	1
10	Pin, Rubber Carriage Stop	W09293	1
11	Pin, 3/16" X 1" Cotter	F05012-21	1
12	BRACKET, FRONT FEED CHAIN MOUNT	095733-1	1
13	BOLT, M10x25 8.8 HEX HEAD	F81003-31	2
14	NUT, M10-8-B HEX NYLON LOCK	F81033-1	2
15	BRACKET WELDMENT, REAR MAIN TUBE COVER MOUNT	087105-1	1

16	COVER, REAR MAIN TUBE	015023	1	
17	WASHER, 8.4 FLAT	F81054-1	2	
18	WASHER, 8.2 SPLIT LOCK	F81054-4	2	
19	BOLT, M8x25-8.8 HEX HEAD	F81002-5	2	

7.4 Lower Track Rollers

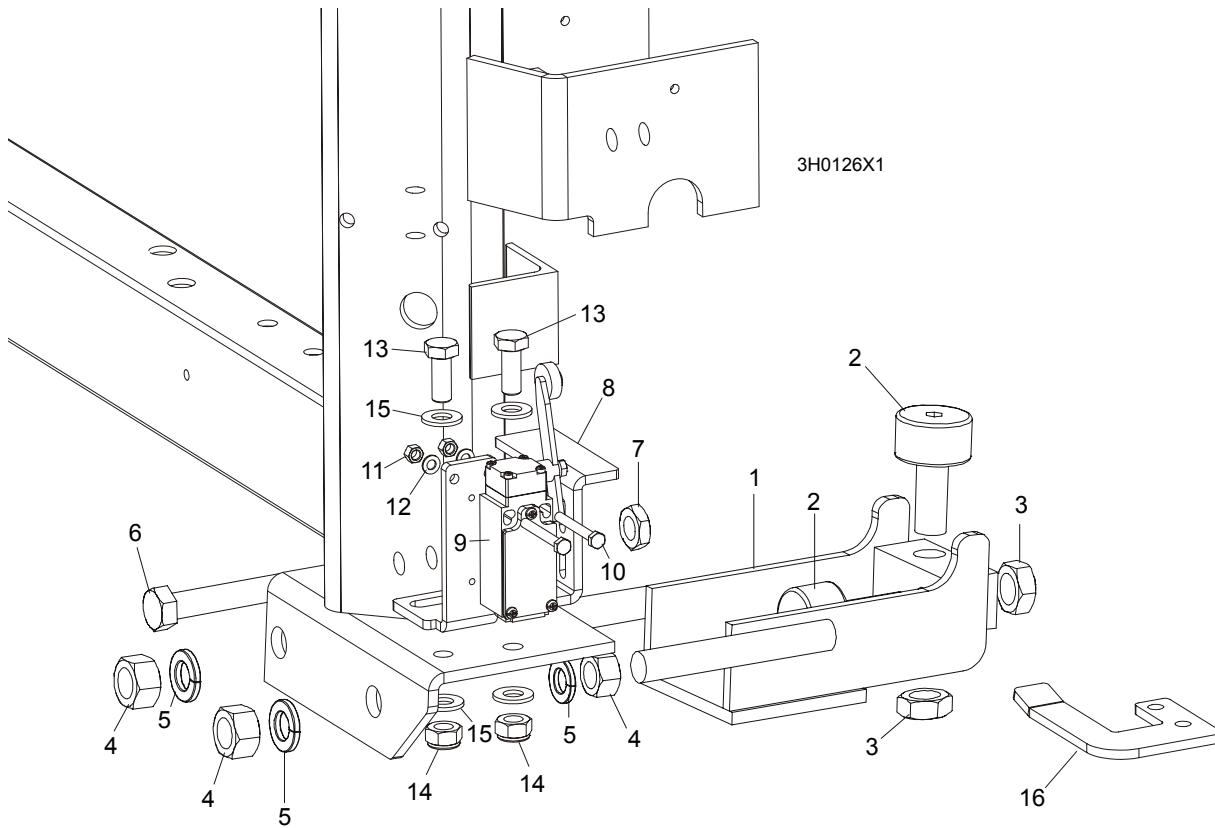

REF	DESCRIPTION (◆ Indicates Parts Available In Assemblies Only)	PART #	QTY.
	ROLLER ASSEMBLY, LOWER TRACK	098741	2
1	Bracket, Lower Track Roller Mounting	098740-1	1
2	Roller, Track Cam Bearing (McGill)	012797	2
3	Nut, 5/8-18 Hex Jam	F05010-11	2
4	Nut, M16, Hexagon, Grade 5.8 Plain	F81036-1	4
5	Washer, 16.3 Split Lock	F81058-2	4
6	BOLT, M12 X 55-8.8 HEX HEAD FULL THREAD	F81004-12	2
7	NUT, M12-8-B HEX JAM	F81034-1	2
8	BRACKET, POWER SUPPLY STRIP AND LIMIT SWITCH	086380-1	1
9	SWITCH, GLCB01A2B LIMIT	086469	1
10	BOLT, M5 X 40 8.8 HEX HEAD	F81000-11	2
11	NUT, M5-8	F81030-1	2
12	WASHER, 5.3 FLAT	F81052-1	2
13	BOLT, M10 X 25 8.8	F81003-11	2
14	NUT, M10 NYLON	F81033-1	2
15	WASHER, 10.5 FLAT	F81055-1	2
16	BRACKET, LIMIT SWITCH	086473-1	1

SECTION 8 BED FRAME ASSEMBLY

8.1 Bed Rail Assembly, Rear

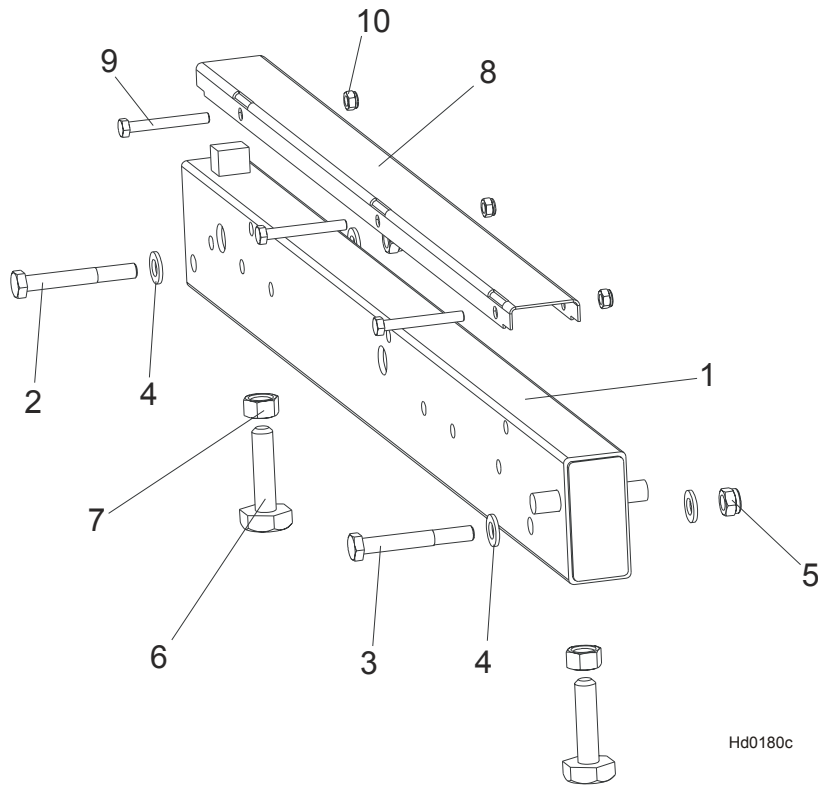

REF	DESCRIPTION (◆ Indicates Parts Available In Assemblies Only)	PART #	QTY.
1	BED RAIL ASSEMBLY, REAR PAINTED	091555	1
2	Bolt, M12 x 90-8.8 Hex Head	F81004-2	1
3	Bolt, M12 x 95-8.8 Hex Head	F81004-29	1
4	Washer, 13 SAE Flat	F81056-1	4
5	Nut, M12-8 Hex Nylon Lock	F81034-2	2
	Bed Rail Bolt, Complete (M16 Bolt + 2xNut)	093710	2
6	Bolt, M16 Bed Rail Adjustment	086809	1
7	Nut, M16-5-B Zinc Hex Head	F81036-5	2
8	COVER, STAINLESS STEEL BED RAIL	099124	1
9	BOLT, M8X65-5.8 ZINC HEX HEAD	F81002-3	3
10	NUT, M8-8-B HEX NYLON ZINC LOCK	F81032-2	3

8.2 Bed Rail Assembly, Front Middle

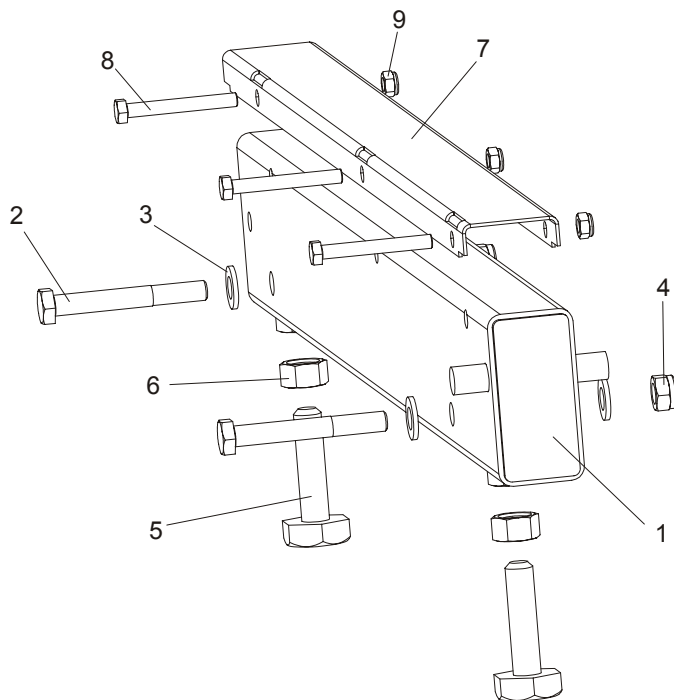

REF	DESCRIPTION (◆ Indicates Parts Available In Assemblies Only)	PART #	QTY.
1	BED RAIL ASSEMBLY, FRONT MIDDLE	091556	1
2	Bolt, M12 x 90-8.8 Hex Head	F81004-2	2
3	Washer, 13 SAE Flat	F81056-1	4
4	Nut, M12-8 Hex Nylon Lock	F81034-2	2
	Bed Rail Bolt, Complete (M16 Bolt + 2xNut)	093710	2
5	Bolt, M16 Bed Rail Adjustment	086809	1
6	Nut, M16-5-B Hex Head Zinc	F81036-5	2
7	COVER, STAINLESS STEEL BED RAIL	099124	1
8	BOLT, M8X65-5.8 ZINC HEX HEAD	F81002-3	3
9	NUT, M8-8-B HEX NYLON ZINC LOCK	F81032-2	3

8.3 Bed Rail Assembly, Rear Middle

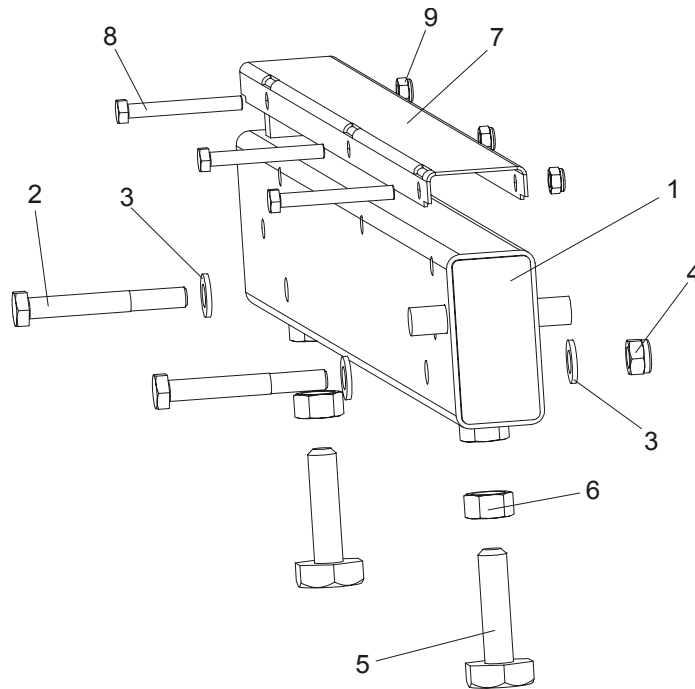

REF	DESCRIPTION (◆ Indicates Parts Available In Assemblies Only)	PART #	QTY.
1	BED RAIL ASSEMBLY, REAR MIDDLE PAINTED	091557	1
2	Bolt, M12 x 90-8.8 Hex Head	F81004-2	2
3	Washer, 13 SAE Flat	F81056-1	4
4	Nut, M12-8 Hex Nylon Lock	F81034-2	2
	Bed Rail Bolt, Complete (M16 Bolt + 2xNut)	093710	2
5	Bolt, M16 Bed Rail Adjustment	086809	1
6	Nut, M16-5-B Hex Head Zinc	F81036-5	2
7	COVER, STAINLESS STEEL BED RAIL	099124	1
8	BOLT, M8X65-5.8 HEX HEAD ZINC	F81002-3	3
9	NUT, M8-8-B HEX NYLON ZINC LOCK	F81032-2	3

8 Bed Frame Assembly

Clamp Mount Assembly, Front (A/DH5/7)

8.4 Clamp Mount Assembly, Front (A/DH5/7)

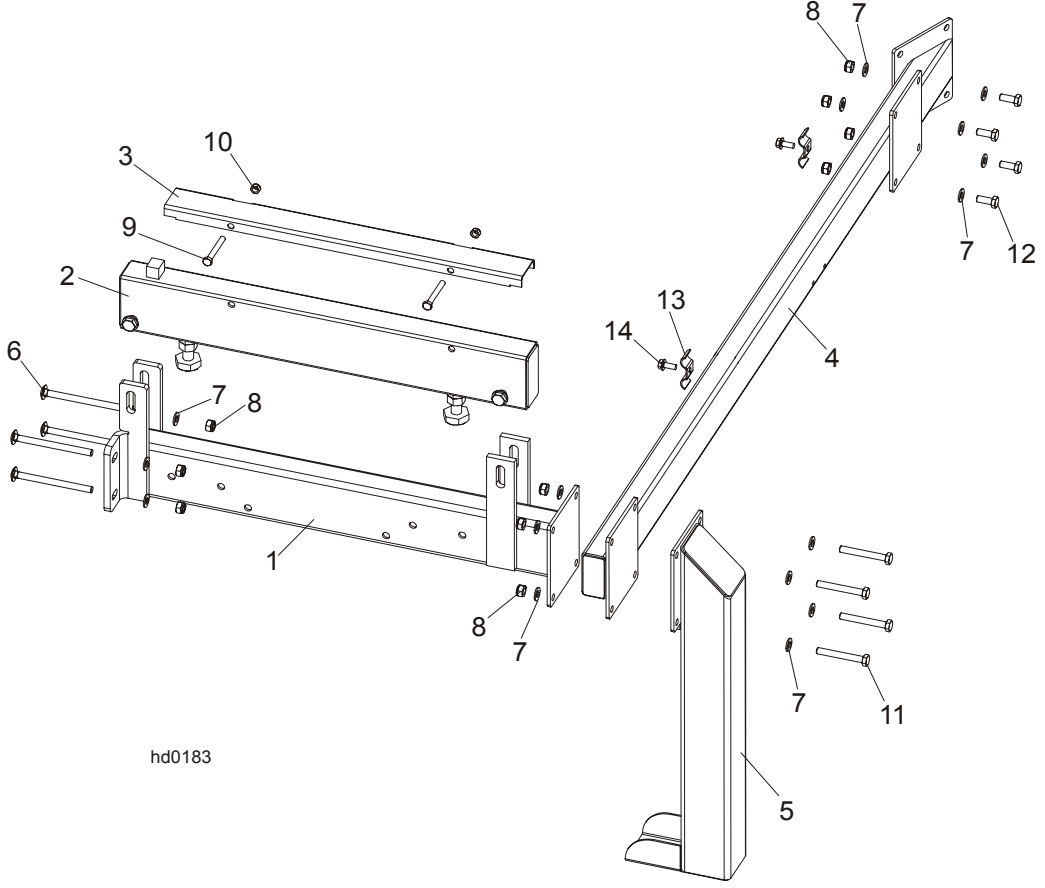

hd0183

REF	DESCRIPTION (◆ Indicates Parts Available In Assemblies Only)	PART #	QTY.
	CLAMP MOUNT ASSEMBLY - FRONT	092937	1
1	Bed Rail Assembly, Front	092903-1	1
2	Bed Rail AH5/DH5	095131-1	1
3	Cover, 22.75 SS LT50 Pivot	099123	1
4	Tube Weldment, Bed Front	092904-1	1
5	Leg, Stationary Left	087450-1	1
6	Bolt, M10 X 125-8.8 Carriage Head	F81003-34	4
7	Washer, M10 Flat Zinc	F81055-1	20
8	Nut, M10 Hex Nylon Zinc Lock	F81033-1	12
9	Bolt, M8 x 65mm Hex Head Zinc Grade 5.8	F81002-3	2
10	Nut, M8 Hex Nylon Zinc Lock	F81032-2	2
11	Bolt, M10x75-8.8 Hex Head Zinc	F81003-15	4
12	Bolt, M10-1.5x25mm Hex Head Grade 8.8	F81003-11	4
13	Plate, 1/4 Hose Clamp Painted	S09245	2
14	Screw, 5/16-18x3/4 Self-tapping	F05015-30	2

8.5 Clamp Mount Assembly, Rear (A/DH5/7)

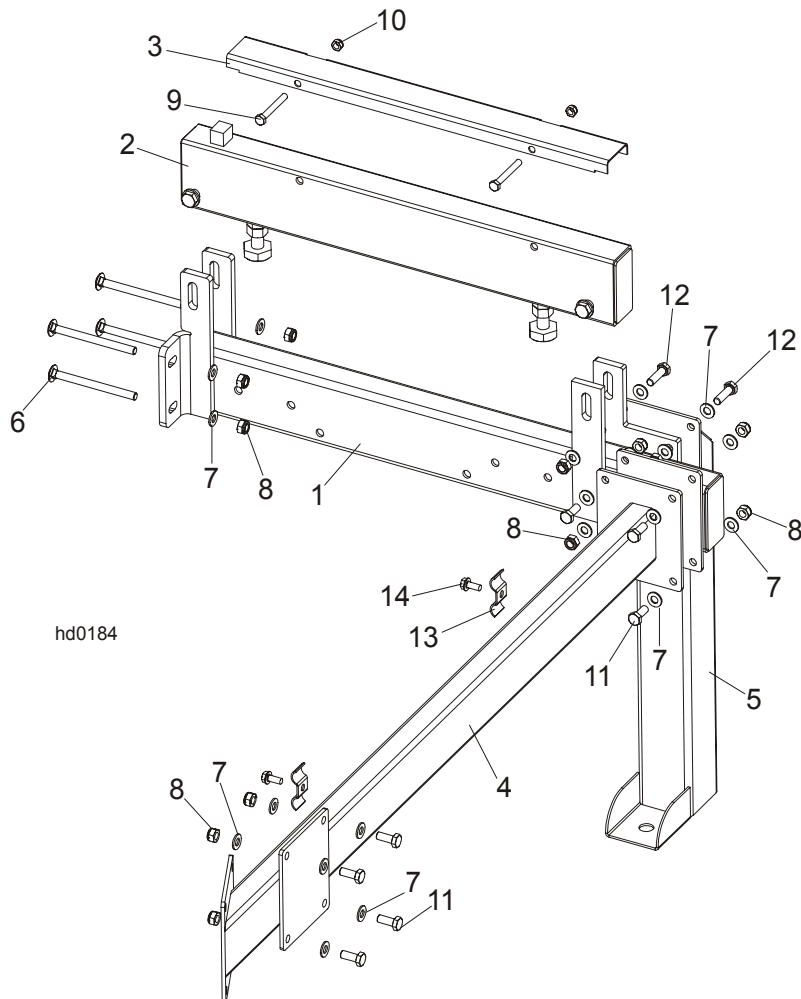

REF	DESCRIPTION (◆ Indicates Parts Available In Assemblies Only)	PART #	QTY.
	CLAMP MOUNT ASSEMBLY - REAR	092938	1
1	Bed Rail Assembly, Rear	092902-1	1
2	Bed Rail AH5/DH5	095131-1	1
3	Cover, 22.75 SS LT50 Pivot	099123	1
4	Tube Weldment, Bed Rear	092907-1	1
5	Leg, Stationary Left	087450-1	1
6	Bolt, M10 X 125-8.8 Carriage Head	F81003-34	4
7	Washer, M10 Flat Zinc	F81055-1	28
8	Nut, M10 Hex Nylon Zinc Lock	F81033-1	16
9	Bolt, M8 x 65-5.8 Hex Head Zinc	F81002-3	2
10	Nut, M8 Hex Nylon Lock Zinc	F81032-2	2
11	Bolt, M10x25-8.8Hex Head Full Thread Zinc	F81003-11	4
12	Bolt, M10x35-8.8 Hex Head Full Thread Zinc	F81003-17	4
13	Plate, 1/4 Hose Clamp Painted	S09245	2
14	Screw, 5/16-18x3/4 Self-tapping	F05015-30	2

8.6 Leg, Stationary

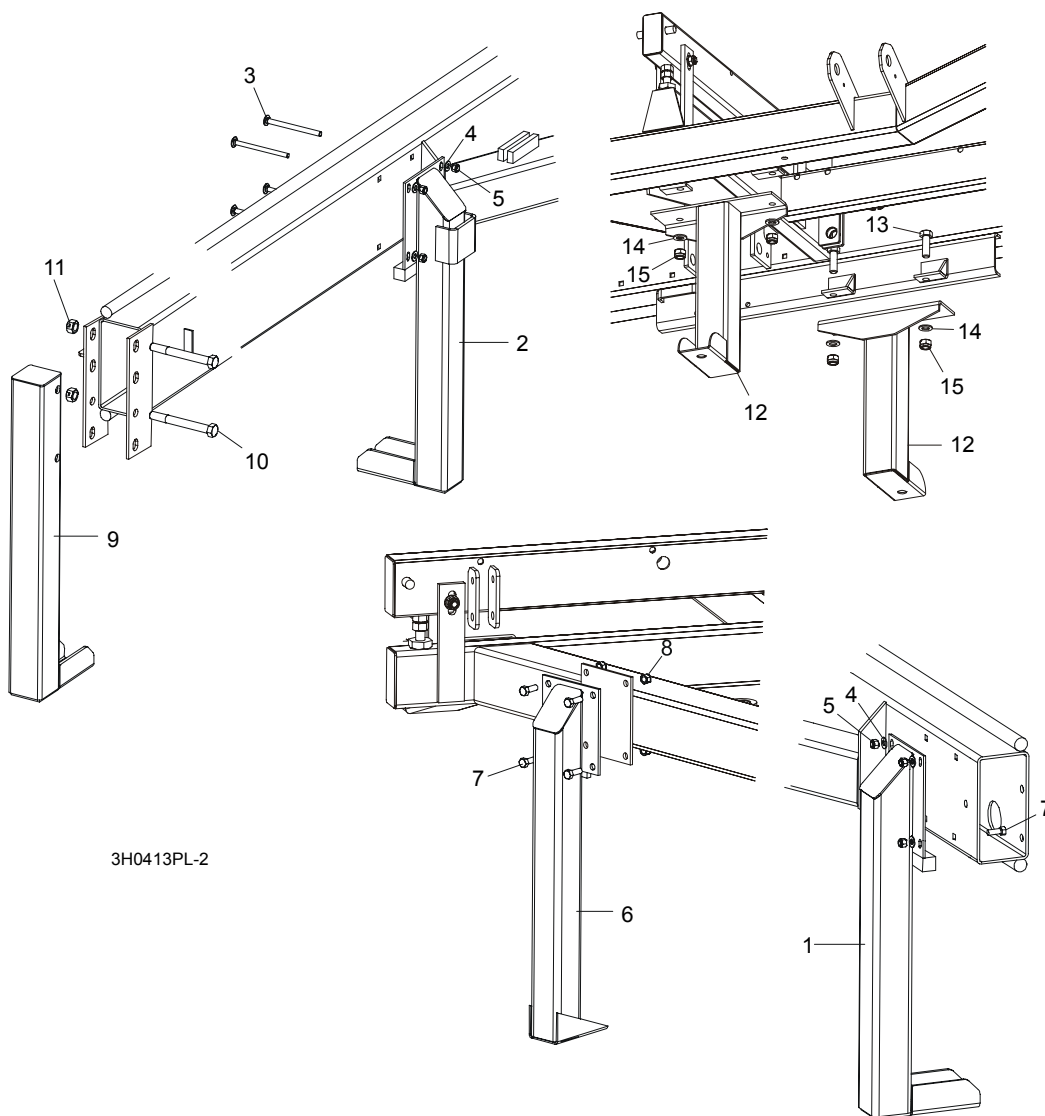

REF	DESCRIPTION (◆ Indicates Parts Available In Assemblies Only)	PART #	QTY.
1	LEG, LONG RIGHT STATIONARY (1 REQ'D FOR LT30; 3 REQ'D FOR LT40)	087451-1	1/3
2	LEG, LONG STATIONARY W/BOARD RETURN TABLE BRACKET	087449-1	1
3	BOLT, M10 X 120-8.8 CARRIAGE HEAD	F81003-33	8/12
4	WASHER, 10.5 FLAT	F81055-1	8/16
5	NUT, M10-8-B HEX NYLON LOCK	F81033-1	8/16
6	LEG, SHORT LEFT STATIONARY	087450-1	2
7	BOLT, M10 X 25-8.8 HEX HEAD	F81003-11	12
8	NUT, M10-8-B HEX NYLON LOCK	F81033-1	12
9	LEG, FRONT STATIONARY	087452-1	1
10	BOLT, M16 X 140-8.8 HEX HEAD GRADE 5	F81006-4	2
11	NUT, M16-8 HEX LOCK ZINC LOCK	F81036-2	2
12	LEG, MIDDLE STATIONARY	087093-1	2
13	BOLT, M16 X 50-8.8 HEX HEAD FULL THREAD ZINC	F81006-7	4

14	WASHER, 17 FLAT ZINC	F81058-1	4	
15	NUT, M16-8 HEX NYLON ZINC LOCK	F81036-2	4	

8.7 Pivot Bed Rail Assembly

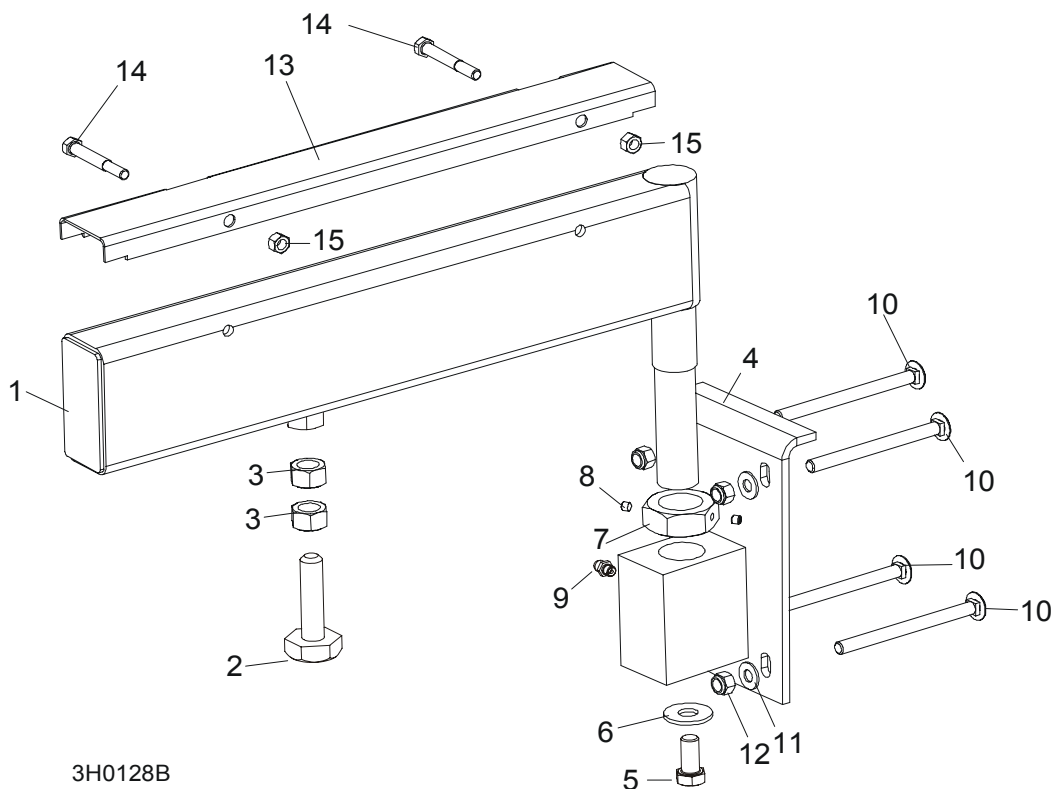

3H0128B

REF	DESCRIPTION (◆ Indicates Parts Available In Assemblies Only)	PART #	QTY.
	PIVOT BED RAIL ASSEMBLY	087829	2
	PIVOT BED RAIL ASSEMBLY	087855	2
1	Pivot Bed Rail Weldment	087852	1
	Pivot Bed Rail Weldment	087848	1
	Bolt Assembly, Bed Rail Adjustment		1
2	Bolt, Bed Rail Adjustment	086809	1
3	Nut, M16-5.8 Hex Zinc	F81036-1	2
4	Bracket, Pivot Rail Mounting	087841-1	1
5	Bolt, M12x25-8.8 Hex Head Full Thread Zinc	F81004-31	1
6	Washer, 15 Flat	F05011-52	1
7	Nut, Pivot Rail Adjustment Nut, Pivot Rail Adjustment	F81036-1 F81039-2	1
8	Screw, 1/4-28 x 1/4" Brass Tip Set	F05005-42	2
9	Fitting, 3/16" Grease	086280	1
10	BOLT, 3M10 X 120-8.8 CARRIAGE HEAD	F81003-14	2
11	BOLT, 3/8-16 X 5" CARRIAGE HEAD	F05007-113	6
12	WASHER, 10.5 FLAT ZINC	F81055-1	8
13	NUT, M16-8 HEX NYLON ZINC LOCK	F81036-2	8
	COVER KIT, PIVOT RAIL STAINLESS STEEL	015926	2
	COVER KIT, PIVOT RAIL STAINLESS STEEL	N/A	2

14	Cover, Stainless Steel Pivot Bed Rail	012994	1	
	Cover, Stainless Steel Pivot Bed Rail	099123	1	
15	Bolt, M8x65-5.8 Hex Head Zinc	F81002-3	4	
16	Nut, M8-8-B Hex Nylon Zinc Lock	F81032-2	4	
WRENCH, BED RAIL ADJUSTMENT (See Section 8.3)		015970	1	

8.8 Log Side Support Assembly (Manual)

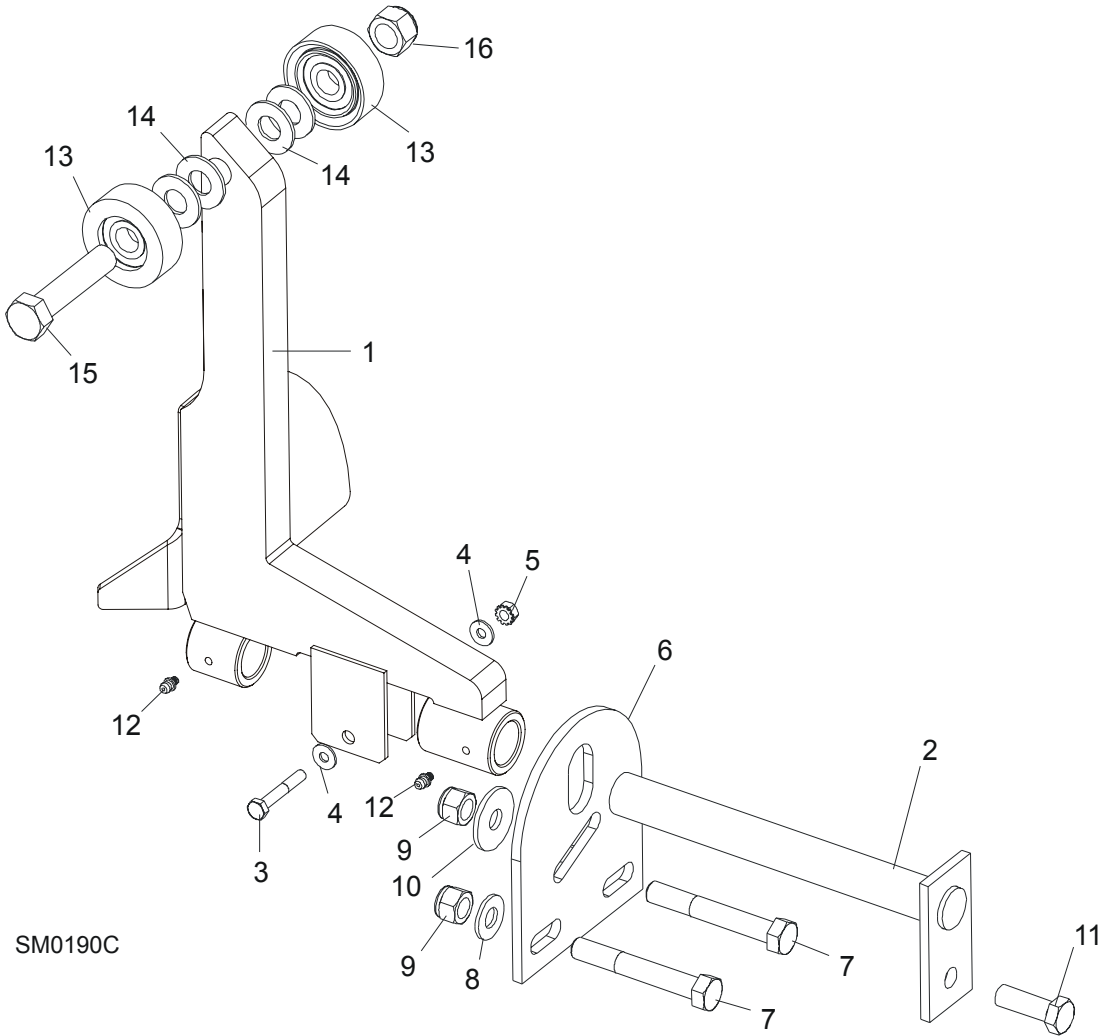

REF	DESCRIPTION (◆ Indicates Parts Available In Assemblies Only)	PART #	QTY.	
1	SUPPORT, LOG SIDE W/GUARD	099785-1	1	
2	PIN, LOG SIDE SUPPORT PIVOT	091549-1	1	
3	BOLT, M8X45-8.8 HEX HEAD FULL THREAD ZINC	F81002-14	1	
4	WASHER, 8.4 FLAT ZINC	F81054-1	2	
5	NUT, M8-8-B HEX NYLON ZINC LOCK	F81032-2	1	
6	PLATE, LOG SIDE SUPPORT END	091591-1	1	
7	BOLT, M12 X 90-8.8 HEX HEAD ZINC	F81004-2	2	
8	WASHER, 13 FLAT ZINC	F81056-1	2	
9	NUT, M12-8 HEX NYLON ZINC LOCK	F81034-2	3	

10	WASHER, .5" X 1.63" X 11" GA.	086184	1	
11	BOLT, M12 X 35-8.8 HEX HEAD FULL THREAD ZINC	F81004-24	1	
12	FITTING, 3/16" GREASE	P04107	2	
13	ROLLER ASSEMBLY, SIDE SUPPORT	015014-1	2	
14	WASHER, 17 FLAT ZINC	F81058-1	2	
15	BOLT, M16X65-8.8-B HEX HEAD FULL THREAD ZINC	F81006-1	1	
16	NUT, M16-8 HEX NYLON ZINC LOCK	F81036-2	1	
	INSTRUCTION SHEET, SIDE SUPPORT ROLLER	015109-526	1	

8.9 LT70 S/M Saw Head Rest Pin Assembly

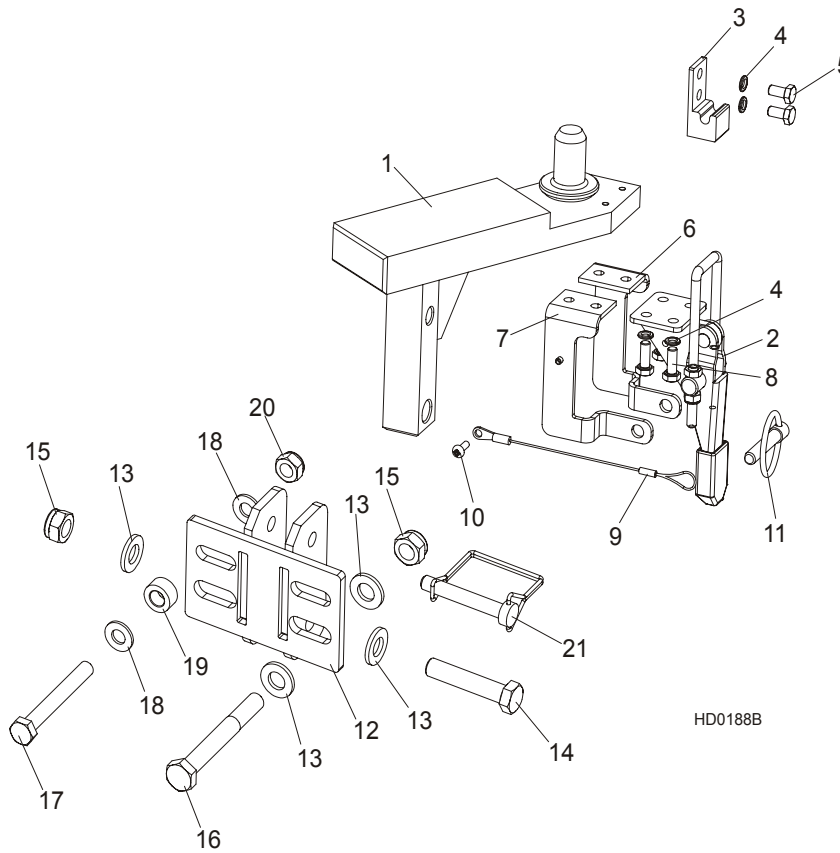

REF	DESCRIPTION (◆ Indicates Parts Available In Assemblies Only)	PART #	QTY.	
	SAW HEAD REST PIN W/LATCH CLAMP, LT70S/M	094660	1	
1	Pin Weldment, LT70S/M Saw Head Rest	094658-1	1	
2	Clamp, GN851.2-320-T4 Latch	094656	1	
3	Latch Bracket, GN851.2-320-T4 Zinc-plated	094659-1	1	
4	Washer, Z 6.1 Split Lock Zinc	F81053-3	6	
5	Bolt, M6x12-8.8 Hex Head Full Thread Zinc	F81001-7	2	
6	Bracket, Locking Right	097102-1	1	
7	Bracket, Locking Left	097103-1	1	
8	Bolt, M6x16-8.8-Fe/Zn5 PN-85/M-82105	F81001-32	4	
9	Lanyard, 3/64x6"	016030	1	
10	Screw, M4x12 -5,8-B- Fe/Zn5 PN-M/82202	F81011-43	1	

11	Pin, 8 BN914(BOSSARD 1364650) Clamp Lock	F81046-2	1	
12	BRACKET, LT40 SAW HEAD REST PIN MOUNT PAINTED	092765-1	1	
13	WASHER, 13 FLAT ZINC	F81056-1	4	
14	BOLT, M12 X 60-8.8 HEX HEAD ZINC	F81004-5	1	
15	NUT, M12-8 HEX NYLON ZINC LOCK	F81034-2	2	
16	BOLT, M12x95-8.8 HEX HEAD ZINC	F81004-29	1	
17	BOLT, M10x80-8.8 HEX HEAD ZINC	F81003-50	1	
18	WASHER, 10.5 FLAT ZINC	F81055-1	2	
19	BUSHING, ZINC-PLATED SPACER	090936-1	1	
20	NUT, M10-8-B HEX NYLON ZINC LOCK	F81033-1	1	
21	PIN, 3/8" X 2 1/4" SNAP RETAINER	014151	1	

8.10 Bed Frame Decals

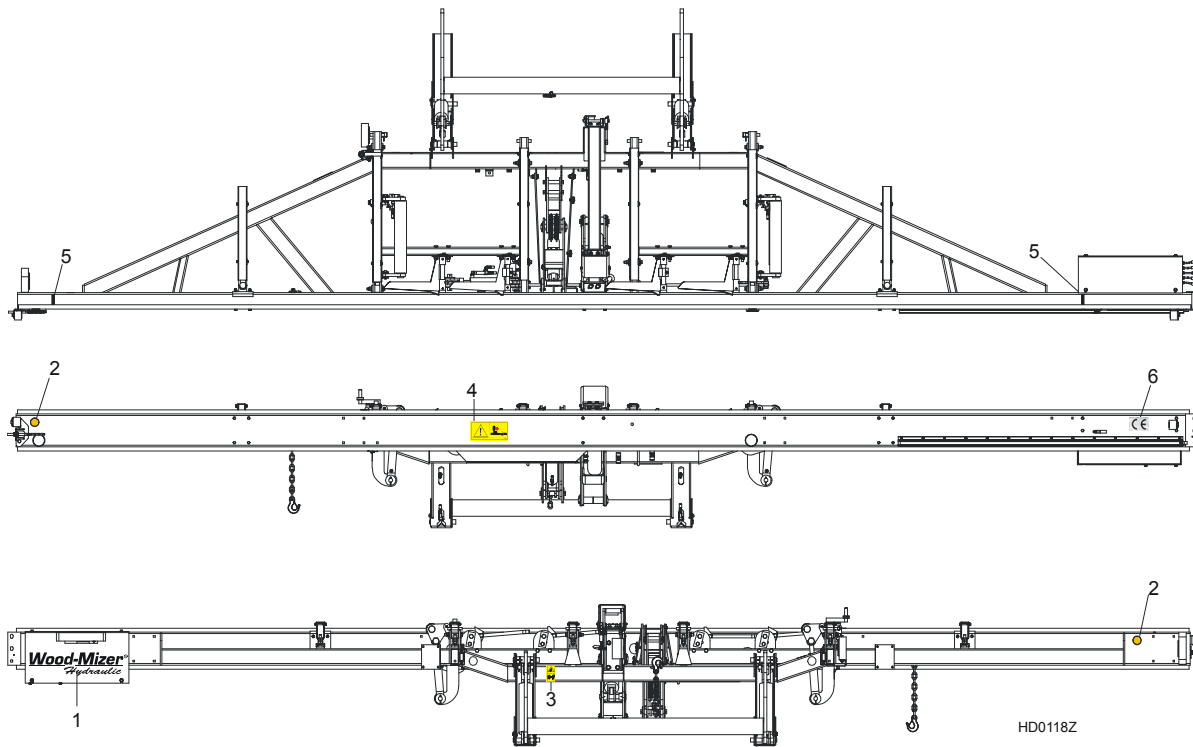

REF	DESCRIPTION (◆ Indicates Parts Available In Assemblies Only)	PART #	QTY.
1	DECAL, WOOD-MIZER SUPER HYDRAULIC LOGO	014168	1
2	DECAL, AMBER REFLECTIVE 2" ROUND	P07453	2
3	DECAL, KEEP AWAY DANGER, PICTOGRAM	099221	1
4	DECAL, SAWMILL TRAILER CAUTION, PICTOGRAM	099542	1
5	DECAL, LOG LIMIT STRIPE	S12051	2
6	DECAL, CE CERTIFIED SAWMILL, SMALL	P85070	1

8.11 Tie Down Chain Assembly

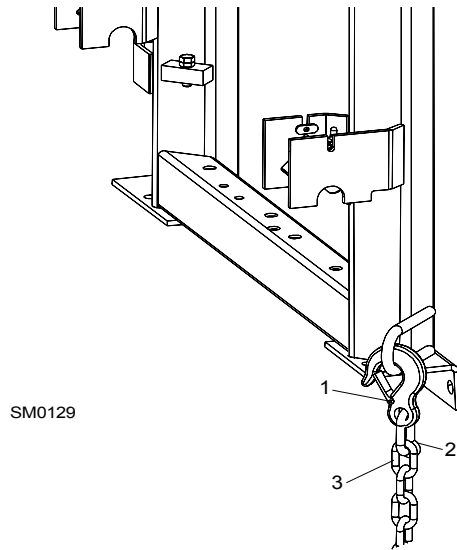

REF	DESCRIPTION (◆ Indicates Parts Available In Assemblies Only)	PART #	QTY.	
	CHAIN ASSEMBLY, TIE DOWN	A04376-1	1	
1	Hook, 5/8" Safety Chain	P12075	1	
2	Screw Closed Chain Link, 10	100767	1	
3	Chain, N-10 x 35, 6 Links	100951	1	

SECTION 9 HYDRAULIC SYSTEM

9.1 Hydraulic Hoses

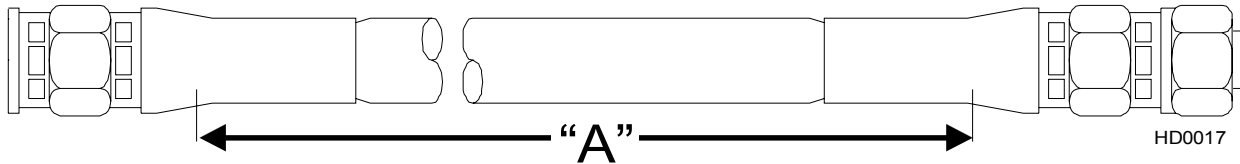

Color Code	LENGTH "A" [m]	Application	Wood-Mizer Part No.
None	0,46	1/4" Hydraulic Pump To Valve	015704
None	0,46	1/4" Hydraulic Pump To Valve	015704
Plain	0,69	3/8" LOG TURNER CYLINDER BASE	014796
Orange	0,53	3/8" LOG TURNER CYLINDER TOP	087775
Yellow	2,66	1/4" FRONT TOE BOARD TOP (LT40S)	087790
	3,81	1/4" FRONT TOE BOARD TOP (LT40M)	087776
Gray	2,66	1/4" FRONT TOE BOARD BASE (LT40S)	087790
	3,81	1/4" FRONT TOE BOARD BASE (LT40M)	087776
Plain	4,21	3/8" SIDE SUPPORT CYLINDER TOP (LT40S)	087791
	4,77	3/8" SIDE SUPPORT CYLINDER TOP (LT40M)	087777
Pink	4,21	3/8" SIDE SUPPORT CYLINDER BASE (LT40S)	087791
	4,77	3/8" SIDE SUPPORT CYLINDER BASE (LT40M)	087777
White	3,68	3/8" CLAMP CYLINDER TOP (LT40S)	087792
	3,98	3/8" CLAMP CYLINDER TOP (LT40M)	087778
Dark Orange	3,27	3/8" CLAMP CYLINDER BASE (LT40S)	087793
	3,83	3/8" CLAMP CYLINDER BASE (LT40M)	087779
Purple	5,18	1/4" REAR TOE BOARD TOP (LT40S)	087794
	5,74	1/4" REAR TOE BOARD TOP (LT40M)	087780
Black	5,18	1/4" REAR TOE BOARD BASE (LT40S)	087794
	5,74	1/4" REAR TOE BOARD BASE (LT40M)	087780
Green	1,58	3/8" LOADING ARM BRANCH TOP	014797
Yellow	1,60	3/8" LOADING ARM BRANCH BASE	014798
Yellow	1,80	3/8" LOADING ARM BRANCH BASE	093329
Blue	4,34	3/8" LOADING ARM CYLINDER TOP (LT40S)	087795
	4,90	3/8" LOADING ARM CYLINDER TOP (LT40M)	087781

TABLE 9-1

Red	4,34	3/8" LOADING ARM CYLINDER BOTTOM (LT40S)	087795
	4,90	3/8" LOADING ARM CYLINDER BOTTOM (LT40M)	087781
Green	4,57	1/4" CLAMP UP (LT40S)	087796
	5,13	1/4" CLAMP UP (LT40M)	087789
Yellow	4,57	1/4" CLAMP DOWN (LT40S)	087796
	5,13	1/4" CLAMP DOWN (LT40M)	087789
White	4,00	1/4" FRONT LOG CLAMP, IN/OUT CYLINDER BOTTOM (A/DH5)	094778
Orange	4,00	1/4" FRONT LOG CLAMP, IN/OUT CYLINDER TOP (A/DH5)	094778
Red	3,80	1/4" FRONT LOG CLAMP, UP/DOWN CYLINDER BOTTOM (A/DH5)	094779
Blue	3,80	1/4" FRONT LOG CLAMP, UP/DOWN CYLINDER TOP (A/DH5)	094779
White	6,00	1/4" REAR LOG CLAMP, IN/OUT CYLINDER BOTTOM (A/DH5)	094780
Orange	6,00	1/4" REAR LOG CLAMP, IN/OUT CYLINDER TOP (A/DH5)	094780
Red	5,60	1/4" REAR LOG CLAMP, UP/DOWN CYLINDER BOTTOM (A/DH5)	094781
Blue	5,60	1/4" REAR LOG CLAMP, UP/DOWN CYLINDER TOP (A/DH5)	094781
Plain	0,40	1/4" HYDRAULIC VALVE TO OIL FLOW CONTROL VALVE (A/DH5)	094782
Plain	0,53	1/4" HYDRAULIC PUMP TO OIL FLOW CONTROL VALVE (A/DH5)	087775
Red	1,50	1/4" FIRST CLAMP, UP/DOWN CYLINDER BOTTOM (A/DH7)	095211
Blue	1,50	1/4" FIRST CLAMP, UP/DOWN CYLINDER TOP (A/DH7)	095211
Red	4,00	1/4" SECOND CLAMP, UP/DOWN CYLINDER BOTTOM (A/DH7)	095212
Blue	4,00	1/4" SECOND CLAMP, UP/DOWN CYLINDER TOP (A/DH7)	095212
Red	8,00	1/4" THIRD CLAMP, UP/DOWN CYLINDER BOTTOM (A/DH7)	095213
Blue	8,00	1/4" THIRD CLAMP, UP/DOWN CYLINDER TOP (A/DH7)	095213
Orange	0,40	1/4" HYDRAULIC VALVE POWER CORD TO CLAMP IN/OUT CYLINDER T-FITTING, BOTTOM (A/DH7)	095214
White	0,40	1/4" HYDRAULIC VALVE POWER CORD TO CLAMP IN/OUT CYLINDER T-FITTING, TOP (A/DH7)	095214
Orange	7,00	1/4" THIRD CLAMP, IN/OUT CYLINDER BOTTOM (A/DH7)	095215
White	7,00	1/4" THIRD CLAMP, IN/OUT CYLINDER TOP (A/DH7)	095215
Orange	2,50	1/4" FIRST/SECOND CLAMP, IN/OUT CYLINDER BOTTOM (A/DH7)	095216
White	2,50	1/4" FIRST/SECOND CLAMP, IN/OUT CYLINDER TOP (A/DH7)	095216
Orange	1,20	1/4" FIRST/SECOND CLAMP, IN/OUT CYLINDER BOTTOM (A/DH7)	095217
White	1,20	1/4" FIRST/SECOND CLAMP, IN/OUT CYLINDER TOP (A/DH7)	095217

TABLE 9-1

Protective Conduits, LT70 Series A/DH Hydraulic Hoses

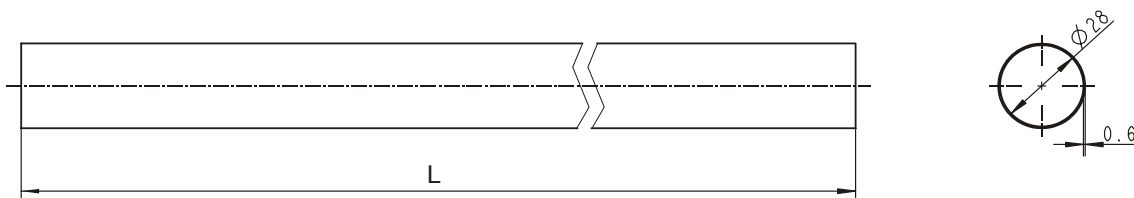

LENGTH "L"	DESCRIPTION (◆ Indicates Parts Available In Assemblies Only)	PART #	QTY.
------------	--	--------	------

0,70	PROTECTIVE CONDUIT, LOG TURNER HOSE	099761	2	
0,28	PROTECTIVE CONDUIT, IN/OUT CYLINDER HOSE - BOTTOM	099762	1	
0,45	PROTECTIVE CONDUIT, IN/OUT CYLINDER HOSE - TOP	099763	1	
1,35	PROTECTIVE CONDUIT, UP/DOWN CYLINDER HOSE - BOTTOM	099764	1	
1,65	PROTECTIVE CONDUIT, UP/DOWN CYLINDER HOSE - TOP	099765	1	

9.2 Hydraulic Control Box, LT70 Series DH3

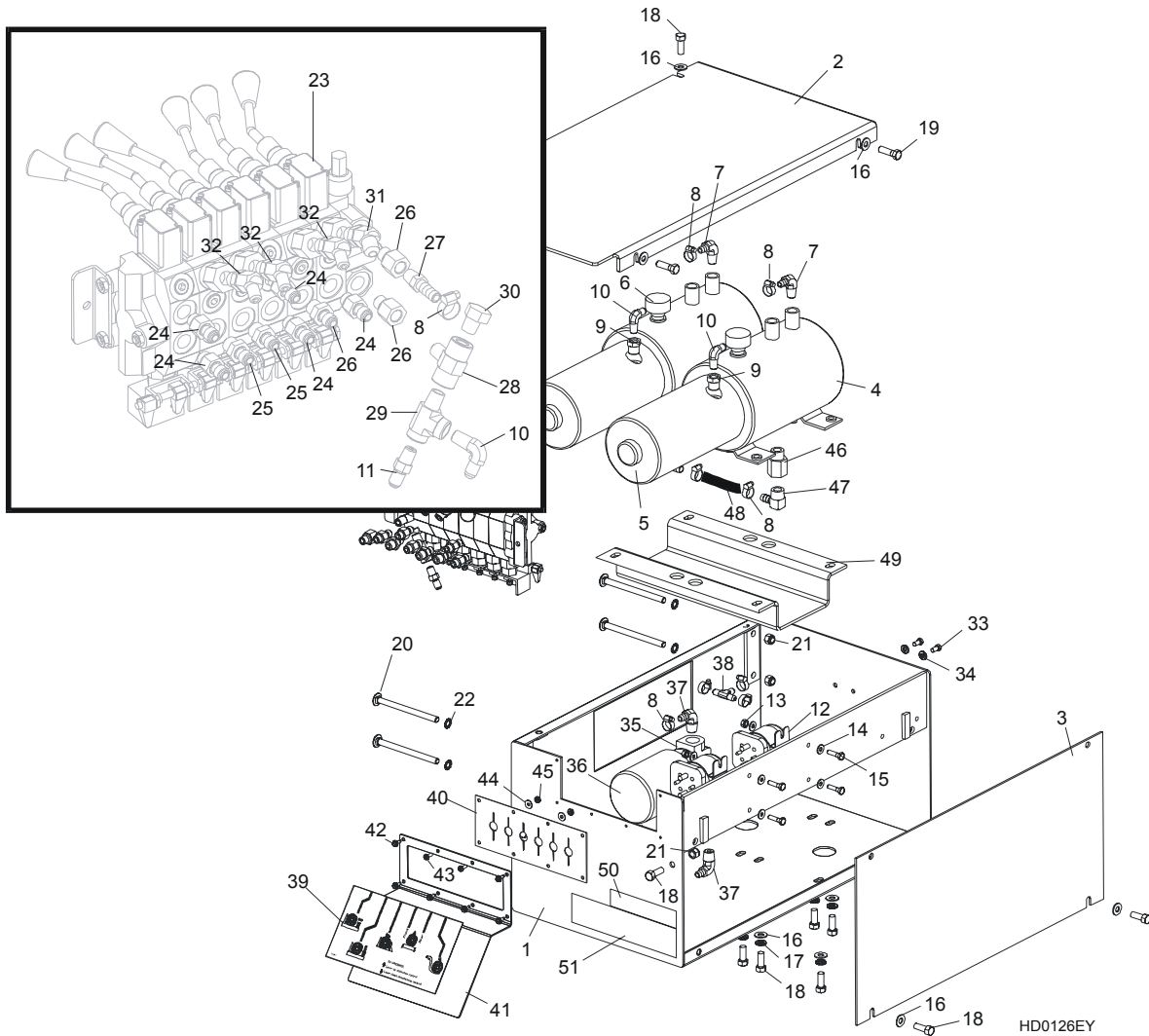

REF	DESCRIPTION (◆ Indicates Parts Available In Assemblies Only)	PART #	QTY.	
1	BOX WELDMENT, SUPER HYDRAULIC PUMP HOUSING	092243-1	1	
2	COVER, SUPER HYDRAULIC PUMP HOUSING TOP	086485-1	1	
3	COVER, SUPER HYDRAULIC PUMP HOUSING SIDE	086484-1	1	
4	PUMP W/MOTOR, HYDRAULIC #M-300-0230	P12701	2	
5	Motor, 12 VDC Hydraulic Pump #08058	P09955	1	
	Brush Kit, 4-Valve Hydraulic Pump Motor #08658	P09585	1	
	Bearing, Base Motor #02318	P12513	1	
6	Cap, Hydraulic Pump Vented Fill #03171	P12817	1	

	O-Ring, Hydraulic Pump/Reservoir #02352	P10198	1	
	Seal, Hydraulic Pump/Motor #02330	P10315	1	
7	FITTING, #6-6 (3/8" NPT) - 3/8" HOSE BARB ELBOW	P12708	2	
8	CLAMP, 11/16" HOSE	P12739	10	
9	FITTING, 3/8" NPT - 1/4" NPT REDUCER	015490	2	
10	FITTING, 1/4" NPT - 1/4" JIC ELBOW	P09142	3	
11	FITTING, 1/4" NPT - 1/4" JIC	P09143	1	
12	SOLENOID, 200A 12V SPST HYDRAULIC PUMP MOTOR	015470	2	
13	NUT, #1/4-20 SELF LOCKING	F05010-9	4	
14	WASHER, 7.4 FLAT	F81056-11	8	
15	BOLT, #1/4-20 X 1" HEX HEAD	F05005-38	4	
	FLUID, 1-QUART DEXRON III HYDRAULIC	P12742	8.5 l	
	FLUID, 1-GALLON EXXON UNIVIS J26 HYDRAULIC	P12824	8.5 l	
	FLUID, 1-GALLON EXXON UNIVIS P13 HYDRAULIC	P12822	8.5 l	
	DECAL, HYDRAULIC FLUID REPLACEMENT	S12825	1	
16	WASHER, 10.5 FLAT	F81055-1	14	
17	WASHER, 10.2 SPLIT LOCK	F81055-2	8	
18	BOLT, 3/8-16 X 1" HEX HEAD	F05007-7	14	
19	BOLT, 3/8-16 X 1 1/4" HEX HEAD	F05007-2	2	
20	BOLT, 3/8-16 X 5" CARRIAGE HEAD	F05007-113	4	
21	WASHER, 3/8" EXTERNAL STAR LOCK	F05011-36	4	
22	NUT, 3/8-16 HEX NYLON LOCK	F05010-10	6	
23	VALVE, HYDRAULIC 6 SECTION (See Form 575 FOR VALVE SERVICE PARTS)	015260	1	
	SWITCH, HYDRAULIC VALVE ELECTRIC	014765	1	
24	FITTING, 3/8" O-RING - 3/8" JIC	014687	5	
25	FITTING, 3/8" O-RING - 1/4" JIC	P26284	3	
26	FITTING, #6 SAE MALE - 1/4" NPT FEMALE	014686	2	
27	FITTING, 1/4" NPT X 3/8" HOSE BARB	014685	1	
28	FITTING, 1/4" NPT BRANCH T	015486	1	
29	FITTING, 1/4" NPT - 1/4" JIC MALE RUN T	P09141	1	
30	PLUG, 1/4" NPT BLANK	096221	1	
31	FITTING, #6 SAE - 3/8" JIC 45° ELBOW	015489	1	
32	FITTING, #6 SAE - 1/4" JIC 45° ELBOW	015488	3	
33	BOLT, 1/4-20 X 1/2" HEX HEAD	F05005-15	2	
34	WASHER, 6.1 SPLIT LOCK	F81053-3	2	
35	MANIFOLD, HYDRAULIC CARTRIDGE FILTER	P22683	1	
36	Filter, S28 Hydraulic Cartridge	P20301	1	
37	FITTING, #6-8 (1/2" NPT) - 3/8" HOSE BARB ELBOW	P12707	2	
38	FITTING, 3/8" HOSE BARB T	015485	1	
39	DECAL, 1997 SUPER HYDRAULIC CONTROL BOX	015364	1	
	HOSE, 3/8" LOW PRESSURE HYDRAULIC	R01892-1	A/R	
40	SEAL, RUBBER VALVE HANDLE	015079	1	
41	PLATE, VALVE HANDLE DECAL	015078	1	
42	SCREW, #10 X 1/2 SLOTTED HEX SELF-TAPPING	F05015-7	6	
43	SCREW, #10-24 X 1/2" SLOTTED HEX HEAD	F05015-4	2	
44	WASHER, 5.3 FLAT	F81052-1	2	

45	NUT, #10-24 SELF-LOCKING HEX	F05010-14	2	
46	FITTING, 1/2" NPT - 1/2" NPT ADAPTOR	015995	2	
47	FITTING, 1/2" NPT - 1/2" HOSE BARB 90° ELBOW	015997	2	
48	HOSE, 1/2" ID HYDRAULIC LOW PRESSURE	R02133	.15 m	
49	GUARD, HYDRAULIC CROSSOVER	015992	1	
	GROUNDING ASSEMBLY, HYDRAULIC PUMP	N/A	1	
	Bolt, 3/8-16 x 1/2" Hex Head Grade 5	F05004-124	2	
	Cable, 1AWG SO Welding	R01971	1 l	
	Terminal, 5/16 1-2Gauge Ring NI Loose	F05092-16	4	
	Washer, 3/8" Star External	F05011-36	3	
50	DECAL, HYDRAULIC WORKING PRESSURE	P85069	1	
51	DECAL, HYDRAULIC FLUID	P85068	1	

9.3 Hydraulic Control Box, LT70 Series DH5/7

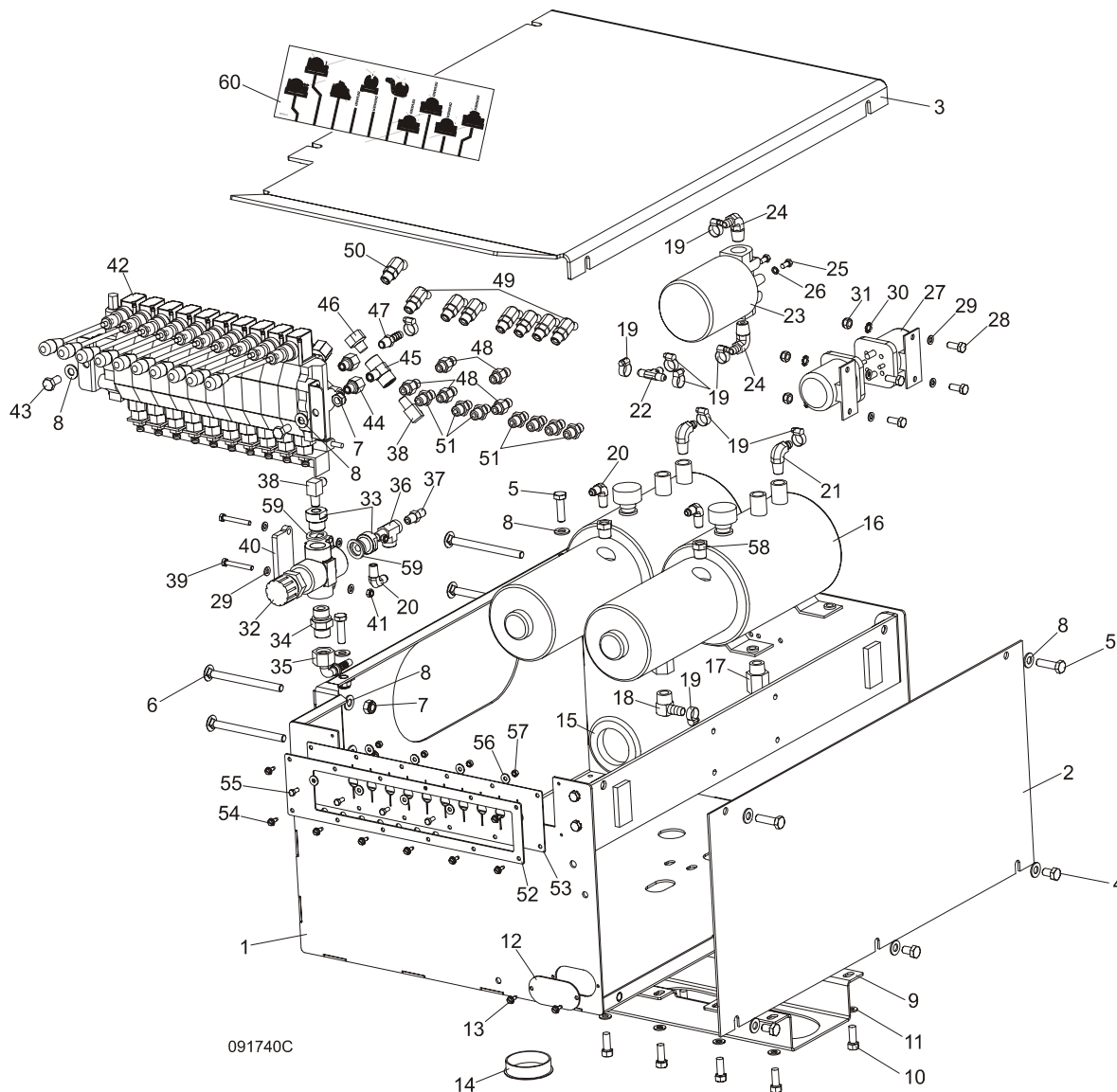

REF	DESCRIPTION (◆ Indicates Parts Available In Assemblies Only)	PART #	QTY.	
	BOX ASSEMBLY, LT40 DH5 HYDRAULIC CONTROL	091740	1	
1	Box Weldment, Hydraulic Pump Housing	091729-1	1	
	Wspornik wzdluzny kompl. skrz. hydr. AC	086518-1	1	
	Bolt, M8X20mm, Hex Head,GR 5.8 Zinc	F81002-4	4	
	Washer, M8 Crown Lock Zinc	F81054-3	4	
2	Cover, AC Hydraulic Pump Housing Side	086484-1	1	
3	Cover, AC/DC Hydraulic Pump Housing Top	091734-1	1	
4	Bolt, M10x16-8.8 Hex Head Full Thread Zinc	F81003-13	3	
5	Bolt, M10x35-8.8 Hex Head Full Thread Zinc	F81003-17	4	
6	Bolt, M10x125 8.8 Carriage Head Zinc	F81003-34	4	
7	Nut, M10-8-B Hex Nylon Zinc Lock	F81033-1	6	
8	Washer, 10.5 Flat Zinc	F81055-1	13	
9	Guard, Hydraulic Crossover	092707-1	1	
10	Screw, 3/8-16x1 HHC	F05007-7	4	
11	Washer, 8.4 Flat Zinc	F81054-1	4	
12	Cap, Hydraulic Control Box	091733-1	1	
13	Bolt, #10-24x1/2, Self Tap	F05015-7	2	
14	Cap, HSA2790 (63.6 Dia.)	092859	1	
15	Seal Rubber, Wire	085614	1	
16	Pump Assy, W/Motor Hyd	P12701	2	
17	Fitting, 1/2NPT-1/2NPT Adaptor	015995	2	
18	Fitting, 1/2Npt-1/2 Hose Barb 90Deg	015997	2	
19	Clamp, 11/16 Hose	P12739	3	
20	Fitting, 1/4NPTx1/4JIC Male Elbow	P09142	3	
21	Fitting, 3/8" NPT - 3/8" Barb Elbow	P12708	2	
22	Fitting, 3/8" Barb Tee	015485	1	
23	Manifold, 1.2" W/Filter	P22683	1	
24	Fitting, 1/2" NPT - 3/8" Barb Elbow	P12707	2	
25	Bolt, 1/4-20 x 1/2" Hex Head Zinc Grade 2	F05005-15	2	
26	Washer, Z6.1 Split Lock Zinc	F81053-3	2	
27	Solenoid, 200A 12V SPST Hyd. Pump 1997	015470	2	
28	Bolt, M8X20mm, Hex Head,GR 5.8 Zinc	F81002-4	4	
29	Washer, 6.4 Flat Zinc	F81053-1	8	
30	Washer, M8 Crown Lock Zinc	F81054-3	4	
31	Nut, M8-8-B Hex Nylon Zinc Lock	F81032-2	4	
32	Valve, MTKA.VB Oil Flow Control	093794	1	
33	Fitting, M22x1.5 / 1/4 - 18 NPT Zinc	093139-1	2	
34	Fitting, VMNW10HS22	094486	1	
35	Fitting, PN10AOL13-90 Elbow	094485	1	
36	Fitting, 1/4 NPT x 1/4 JIC Male Run Tee	P09141	1	
37	Fitting, 1/4NPTx1/4JIC Male	P09143	1	
38	Fitting, 3/8 JIC - 1/4 NPT 90L	015491	2	
39	Bolt, M6x45-8.8 Hex Head Zinc	F81001-6	2	
40	Plate, MTKA Control Valve Spacer Zinc-Plated	094477-1	1	
41	Nut, M6-8-B Hex Nylon Zinc Lock	F81031-2	2	

42	Valve, HDS11/10 6-Section Hydraulic	091344	1	
43	Bolt, M10x20-5.8 Hex Head Full Thread Zinc	F81003-1	2	
44	Fitting, #6 SAE Male - 1/4" NPT Female	014686	2	
45	Fitting, 1/4NPT Branch Tee	015486	1	
46	Plug, 1/4" NPT Blank	096221	1	
47	Fitting, 1/4" NPT x 3/8" Hose Barb	014685	1	
48	Fitting, 3/8" O-Ring - 3/8" JIC	014687	5	
49	Fitting, #4 SAE - #6 SAE 45° Elbow	015488	7	
50	Fitting, #6 SAE 45° Elbow	015489	1	
51	Fitting, 3/8" O-Ring - 1/4" JIC	P26284	7	
52	Plate, 10-Section Valve Painted	091826-1	1	
53	Guard, 10-Section Valve Rubber	091739	1	
54	Screw, #10-24x1/2 Self-Tapping	F05015-7	8	
55	Bolt, M5x12-5.8 Hex Head Full Thread Zinc	F81000-5	4	
56	Washer, 5.5 Special Flat Zinc-Plated	F81052-3	8	
57	Nut, M5-8 Hex Zinc	F81030-1	4	
58	Fitting, 3/8" NPT - 1/4" NPT Reducer	015490	2	
59	Washer, 22x26 Copper	F81061-5	2	
60	Decal, DH5 Hydraulic Control Box	094795	1	
	Decal, DH7 Hydraulic Control Box	094970	1	

9.4 Hydraulic Power Supply Strip

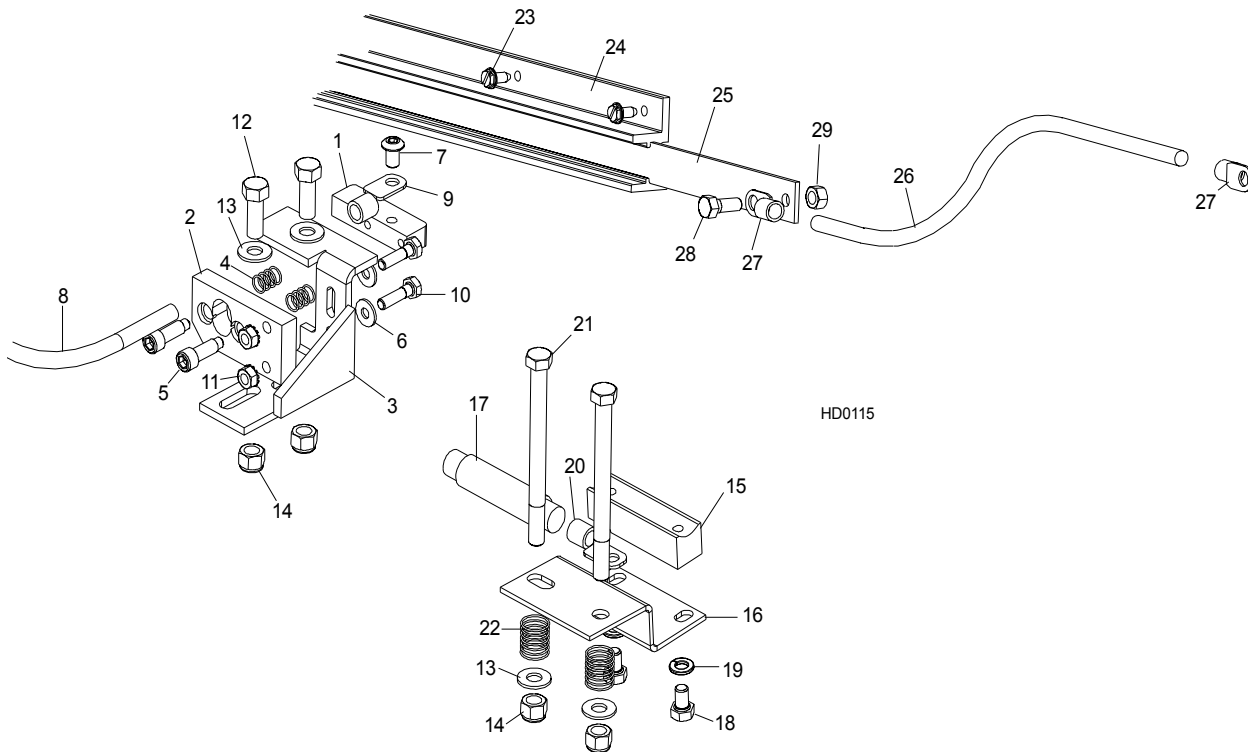

REF	DESCRIPTION (◆ Indicates Parts Available In Assemblies Only)	PART #	QTY.	
	CONTACT KIT, HYDRAULIC 6" POWER SUPPLY	A12042-N	1	

	Contact Hardware Kit	A10073-N	1	◆
	Contact Assembly, Hydraulic Power Supply (Positive)	085968	1	
1	Contact, Hydraulic Power Supply (Positive)	015253	1	
2	Insulator, Positive Contact	S10072	1	
3	Bracket, Positive Contact Mounting	086380-1	1	
4	Spring, Positive Contact	P10077	2	
5	Bolt, 5/16" X 3/4" Shoulder (1/4-20 Thread)	F05006-44	2	
6	Washer, 7.4 Flat Zinc	F81056-11	2	
7	Bolt, 5/16-18 x 1/2" Socket Button Head	F05006-20	1	
	Cable Assy, Hydraulic Positive Contact	015885	1	
8	Cable, #1 Weld	R01948	0.75m	◆
9	Terminal, 35 Ring #2 Gauge	F81066-3	2	
10	Bolt, 1/4-20 X 1" Hex Head Zinc Grade 2	F05005-38	2	
11	Nut, 1/4-20 Self-Locking Hex Zinc	F05010-9	2	
12	Bolt, 3/8-16 X 1" Hex Head Zinc Grade 5	F05007-87	2	
13	Washer, 10.5 Flat Zinc	F81055-1	4	
14	Nut, 3/8-16 Hex Nylon Lock	F05010-10	4	
	Contact Assembly, Hydraulic Power Supply (Ground)	A10066	1	
15	Contact, Hydraulic Power Supply (Ground)	015264	1	
16	Bracket, Ground Contact Mounting	015265	1	
17	Cable, #1 Weld	R01948	.63m	◆
18	Bolt, 5/16-18 X 1/2" Hex Head Zinc Grade 5	F05006-15	2	
19	Washer, 8.2 Split Lock Zinc	F81054-4	2	
20	Terminal, 35 Ring #2 Gauge	F81066-3	1	
21	Bolt, 3/8-16 X 4 1/2" Hex Head Zinc Grade 2	F05007-35	2	
22	Spring, Ground Contact	P04282	2	
23	Screw, 1/4-20 X 1/2" "23" Type Self-Tapping	F05015-1	14	
24	Housing, 6' Contact Strip	P11976	1	
25	Strip, 6' Contact	S10075	1	◆
26	Cable, #2 Weld	R80583-21		◆
27	Terminal, 35 Ring #2 Gauge	F81066-3		
28	Bolt, 5/16-18 X 3/4" Hex Head Black Nylon	F05006-45	1	
29	Nut, 5/16-18 Hex Black Nylon	F05010-86	1	
	Tube, 5/8" Heat Shrink	R01950-5	m	◆
	Grommet, 5/8" Wire	P04137		

9.5 Hydraulic Log Loader

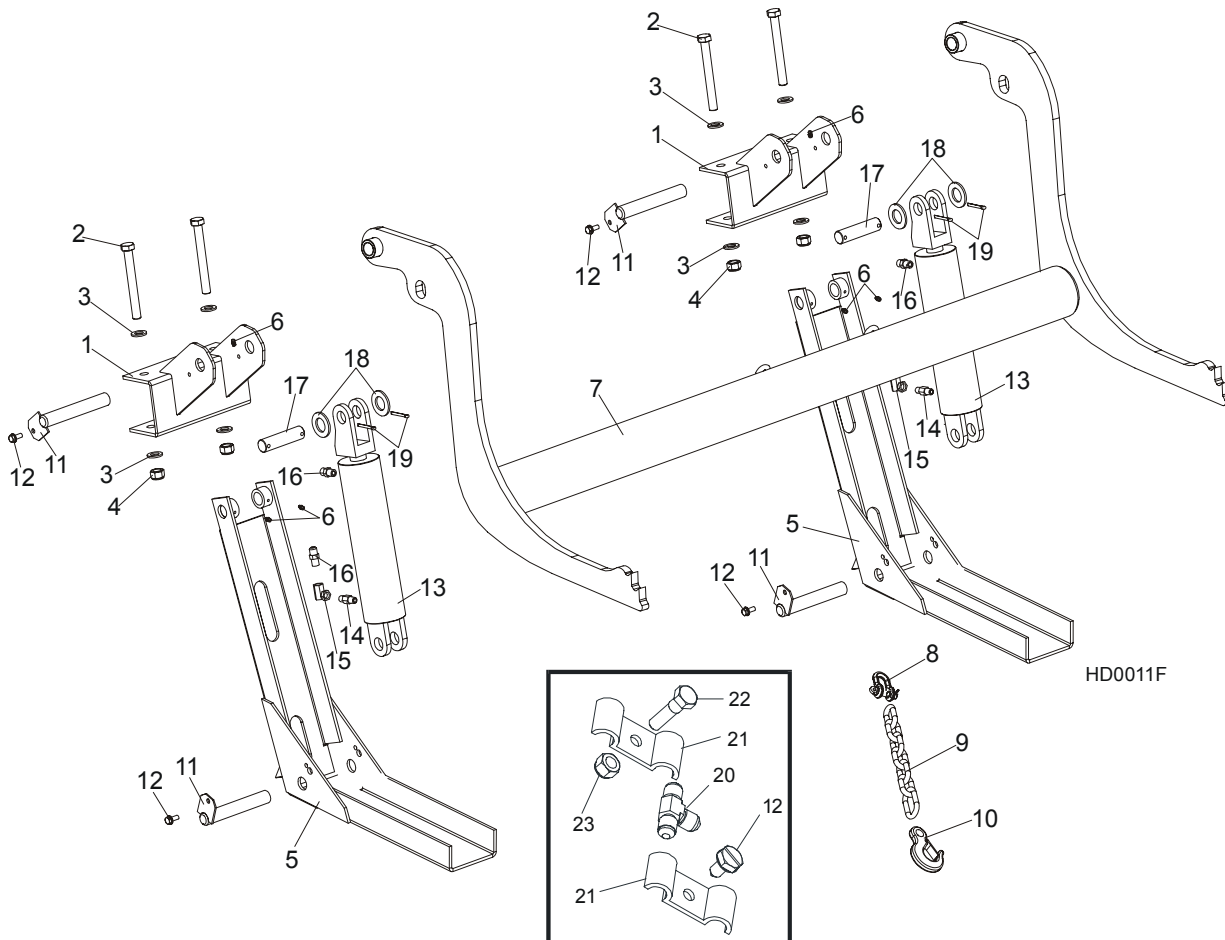

REF	DESCRIPTION (◆ Indicates Parts Available In Assemblies Only)	PART #	QTY.
	LOADER KIT, HYDRAULIC LOG	090527	1
1	Bracket, Hydraulic Log Loader	087938-1	1
2	Bolt, M16x140mm Hex Head Zinc Grade 8.8	F81006-4	4
3	Washer, M16 Flat Zinc	F81058-1	8
4	Nut, M16 Hex Nylon Zinc Lock	F81036-2	4
	Channel, Hydraulic Log Loading Foot Complete	090049	2
5	Channel, Hydraulic Log Loading Foot	090048-1	2
6	Fitting, 3/16x3/16 Straight Grease	P04107	6
	Arm, Hydraulic Log Loading Complete	090044	1
7	Arm, Hydraulic Log Loading	090006-1	1
8	Shackle, M-WL. .63	086540	1
9	Chain, Hydraulic Log Loader Safety	A04376	1
10	Hook, 5/8 Safety Chain	P12075	1
11	Pin, Turner Arm	099127-1	4
12	Screw, 5/16-18x3/4 Self-Tapping	F05015-30	4
13	Cylinder Assy, Log Loading Super	015562	2
14	Fitting, 1/4NPT Velocity Fuse 5.0GPM	015750	2

15	Fitting, 1/4NPT-1/4JIC Swivel Elbow	P12199	2	
16	Fitting, 3/8JIC-1/4NPT Straight	015560	4	
17	Pin, Cylinder Hydraulic	086979-1	2	
18	Washer, 28 Flat Zinc	F81061-1	4	
19	Pin, 5x40 Cotter	F81043-31	4	
20	Fitting, 3/8 Barb Tee	015485	1	
21	Clamp, 3/8 Hose	016041	2	
22	Bolt, 5/16-18x1 Hex Head Zinc Grade 2	F05006-1	1	
23	Nut, 5/16-18 Nylon Zinc Lock	F05010-58	1	

9.6 Hydraulic Log Turner

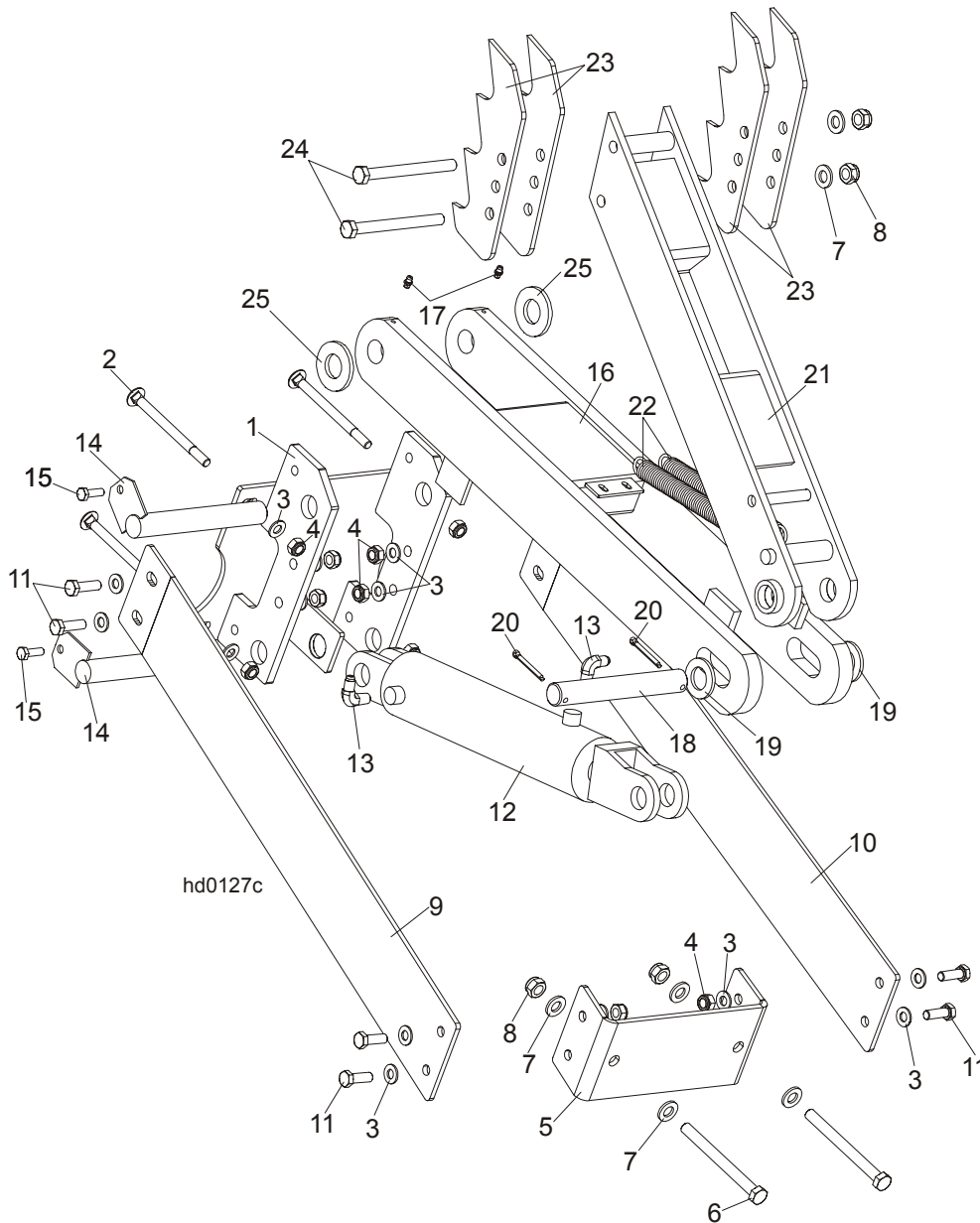

REF	DESCRIPTION (◆ Indicates Parts Available In Assemblies Only)	PART #	QTY.	
	HYDRAULIC LOG TURNER OPTION (S/M TYPE FRAME)	088711	1	
1	Bracket, Hydraulic Log Turner (S/M TYPE FRAME)	088710-1	1	
2	Bolt, M10x120 8.8 Carriage Head Zinc	F81003-33	4	
3	Washer, M10 Flat Zinc	F81055-1	20	
4	Nut, M10 Hex Nylon Zinc Lock	F81033-1	12	
5	Bracket, Hydraulic Log Turner Front	091046-1	1	
6	Bolt, M12x130-8.8 Hex Head Zinc	F81004-36	2	
7	Washer, M12 Flat Zinc	F81056-1	6	
8	Nut, M12 Hex Nylon Zinc Lock	F81034-2	4	
9	Plate, Hydraulic Log Turner Left	091048-1	1	
10	Plate, Hydraulic Log Turner Right	091049-1	1	
11	Bolt, M10x30mm Hex Head Zinc Grade 5.8	F81003-2	8	
	Cylinder Assy, Log Turner Super	015563	1	
12	Cylinder, CJ-S305-16-63/28/203 Hydraulic	088679	1	
13	Fitting, 1/4NPTx1/4JIC Male Elbow	P09142	2	
14	Pin, Log Turner Mount	088667-1	2	
15	Bolt, M8 x 25mm Hex Head Zinc Grade 5.8	F81002-5	2	
16	Arm, Hydraulic Log Turner Link	088060-1	1	
17	Fitting, M6 Grease	086280	2	
18	Pin, 25 X 180	088664	1	
19	Washer, 25 Zinc	F81061-3	2	
20	Pin, 5x40 Cotter	F81043-31	2	
21	Arm, Hydraulic Log Turner Painted	088067-1	1	
22	Spring, 7/8x8 1/2x1/8 Extension	P09136	2	
23	Claw, Hydraulic Log Turner	088082-1	4	
24	Bolt, M12x130-8.8 Hex Head Zinc	F81004-36	2	
25	Washer, GTM-2644-015	093359	2	

9.7 Hydraulic Log Side Supports (S/M Type Frame)

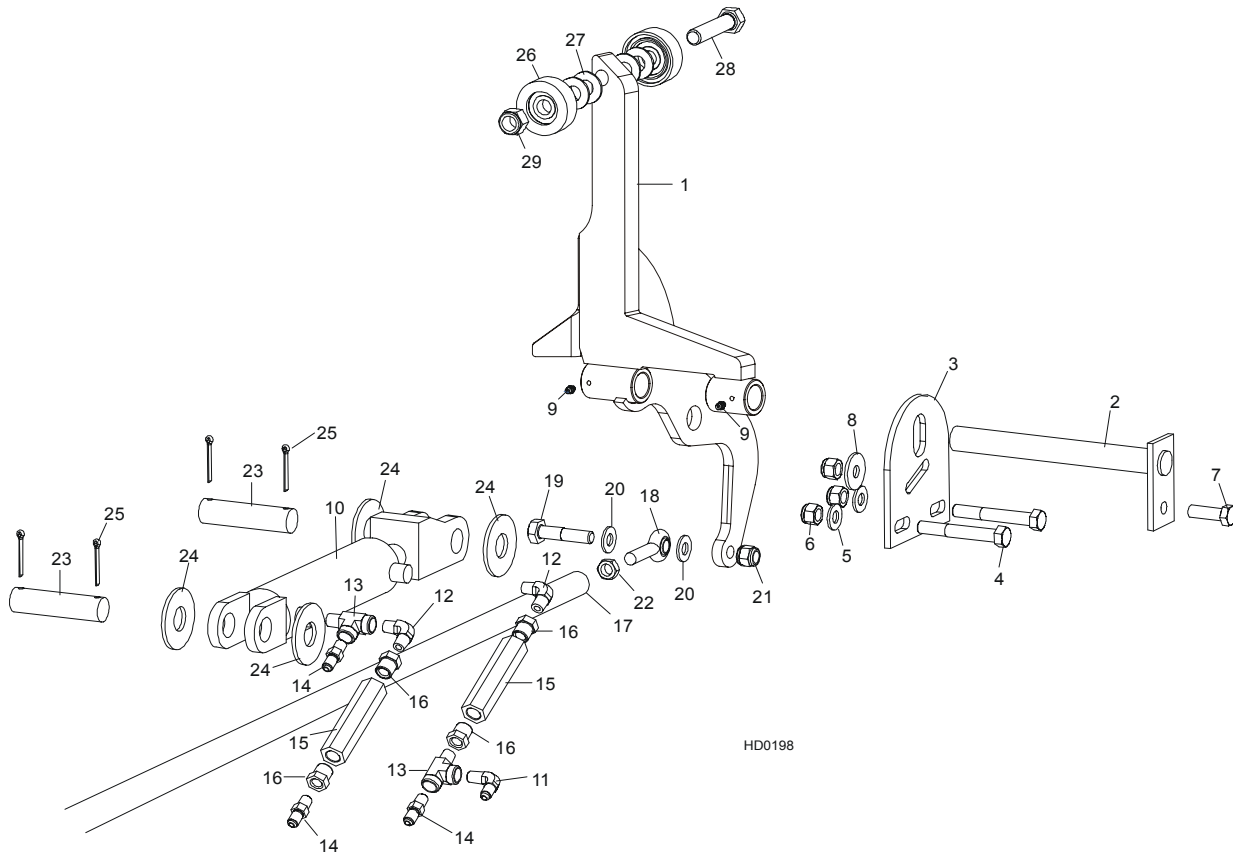

HD0198

REF	DESCRIPTION (◆ Indicates Parts Available In Assemblies Only)	PART #	QTY.	
1	SUPPORT, HYDRAULIC LOG SIDE W/GUARD	099788-1	1	
2	PIN, LOG SIDE SUPPORT PIVOT	091549-1	1	
3	PLATE, LOG SIDE SUPPORT END	091591-1	1	
4	BOLT, M12X75-8.8 HEX HEAD ZINC	F81004-21	2	
5	WASHER, 13 FLAT ZINC	F81056-1	2	
6	NUT, M12-8 HEX NYLON ZINC LOCK	F81034-2	3	
7	BOLT, M12 X 35-8.8 HEX HEAD FULL THREAD ZINC	F81004-24	1	
8	WASHER, 15 SPECIAL FLAT ZINC	F81057-3	1	
9	FITTING, 3/16" GREASE	P04107	4	
	CYLINDER ASSY, 2x6 SIDE SUPPORT SUPER	015561	1	
10	Cylinder, CJ-S270-16-50/28/152 Hydraulic	088678	1	◆
	Seal Kit, 6" x 2" Hydraulic Cylinder	P12954	1	
11	Fitting, 3/8JIC-1/4NPT 90L	015491	2	
12	Fitting, C3529x4 90° Pipe	P09140	4	
13	Fitting, C3759x4 Male 'T'	P09141	2	
14	Fitting, 3/8JIC-1/4NPT Str	015560	2	
15	Valve, Hydraulic Sequence	015484	2	
16	Fitting, 3/8" NPT - 1/4" NPT Reducer	015490	4	
17	ROD, HYDRAULIC SIDE SUPPORT LINK	089374-1	1	

18	END, RIGHT ROD	087035	1	
	END, LEFT ROD	087036	1	
19	BOLT, M12 X 45-8.8 HEX HEAD ZINC	F81004-32	2	
20	WASHER, 13 FLAT ZINC	F81056-1	4	
21	NUT, M12-8 HEX NYLON ZINC LOCK	F81034-2	2	
22	NUT, M12-04-A RIGHT HEX JAM	F81034-6	1	
	NUT, M12-04-A LEFT HEX JAM	F81034-7	1	
23	PIN, CYLINDER MOUNT	086979-1	2	
24	WASHER, 28 FLAT ZINC	F81061-1	4	
25	PIN, 5 X 40 COTTER	F81043-31	4	
	ROLLER KIT, SIDE SUPPORT	015109	2	
26	Roller Assembly, Side Support	015014-1	2	
27	Washer, 17 Flat Zinc	F81058-1	4	
28	BOLT, M16x65MM, HH F/THRD, GRADE 5.8, ZINC	F81006-1	1	
29	NUT, M16,HEX, NYLON ZINC LOCK	F81036-2	1	
	Instruction Sheet, Side Support Roller	015109-526	1	

9.8 Hydraulic Pull Down Clamp

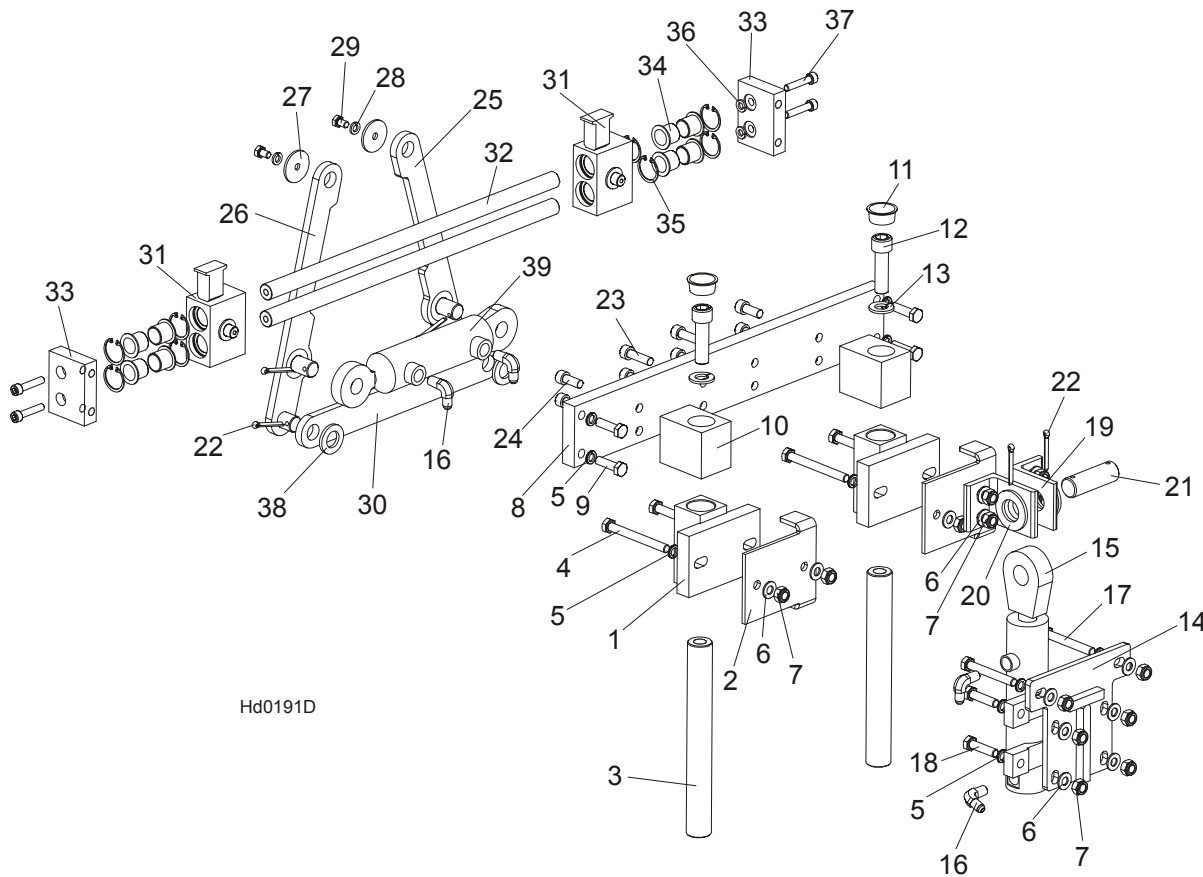

REF	DESCRIPTION (◆ Indicates Parts Available In Assemblies Only)	PART #	QTY.
	LEFT HYDRAULIC LOG CLAMP ASSEMBLY, COMPLETE	094129	1

1	Block Weldment, Log Clamp Up/Down Painted	090545-1	2	
2	Bracket, Log Clamp Mount Painted	094098-1	2	
3	Pin, Log Clamp Up/Down	088631	2	
4	Bolt, M10x95-8.8-B Hex Head Zinc	F81003-71	4	
5	Washer, 10.2 Split Lock Zinc	F81055-2	14	
6	Washer, 10.5 Flat Zinc	F81055-1	14	
7	Nut, M10-8-B Hex Nylon Zinc Lock	F81033-1	14	
8	Beam, Log Clamp Main Zinc-plated	094115-1	1	
9	Bolt, M10x35-8.8 Hex Head Full Thread Zinc	F81003-17	4	
10	Block, Log Clamp Up/Down Painted	094124-1	2	
11	Plug, M33 Thread #12428	089839	2	
12	Screw, M16x55-8.8 Hex Socket Head Cap Zinc	F81006-18	2	
13	Washer, 16.3 Split Lock Zinc	F81058-2	2	
14	Plate Weldment, Hydraulic Cylinder Mounting Painted	094094-1	1	
15	Cylinder, CJ7F-16/40/22 + UE2-40W Hydraulic	091346	1	
16	Fitting, 90° Male Elbow	P09142	2	
17	Bolt, M10x75-8.8 Hex Head Zinc	F81003-15	2	
18	Bolt, M10x40-8.8 Hex Head Full Thread Zinc	F81003-16	4	
19	Bracket, Hydraulic Cylinder Mounting Painted	094127-1	2	
20	Washer, 28 Flat Zinc	F81061-1	2	
21	Pin, 25x75 Zinc-plated	088659-1	1	
22	Pin, S-Zn 5x40 Cotter Zinc	F81043-31	4	
23	Screw, M10x35 8.8 Hex Socket Head Cap Zinc	F81003-56	4	
24	Screw, M10x25 8.8 Hex Socket Head Cap Zinc	F81003-32	4	
25	Link, Log Clamp In/Out Side Zinc-plated (1)	094097-1	1	
26	Link, Log Clamp In/Out Side Zinc-plated (2)	094099-1	1	
27	Washer, Zinc-plated Spacer	094128-1	1	
28	Washer, 8.2 Split Lock Zinc	F81054-4	2	
29	Bolt, M8x12-8.8 Hex Head Full Thread Zinc	F81002-6	2	
30	Arm, Log Clamp In/Out Zinc-plated	094092-1	1	
31	Jaw Weldment, Log Clamp Zinc-plated	094120-1	2	
32	Rod, Log Clamp Jaw Guide	094116	2	
33	Plate, Locking Zinc-plated	094117-1	2	
34	Bushing, JFM-2023-21 Flanged	094113	8	
35	Ring, W 31 Inside Retaining	F81090-15	8	
36	Washer, 8.2 Split Lock Zinc	F81054-4	4	
37	Screw, M8x40-8.8 Hex Socket Head Cap Zinc	F81002-29	4	
38	Washer, 21 Flat Zinc	F81059-2	2	
39	Cylinder SJ2F-16-40/22/80 Hydraulic	093880	1	

9.9 Hydraulic Log Clamp - main

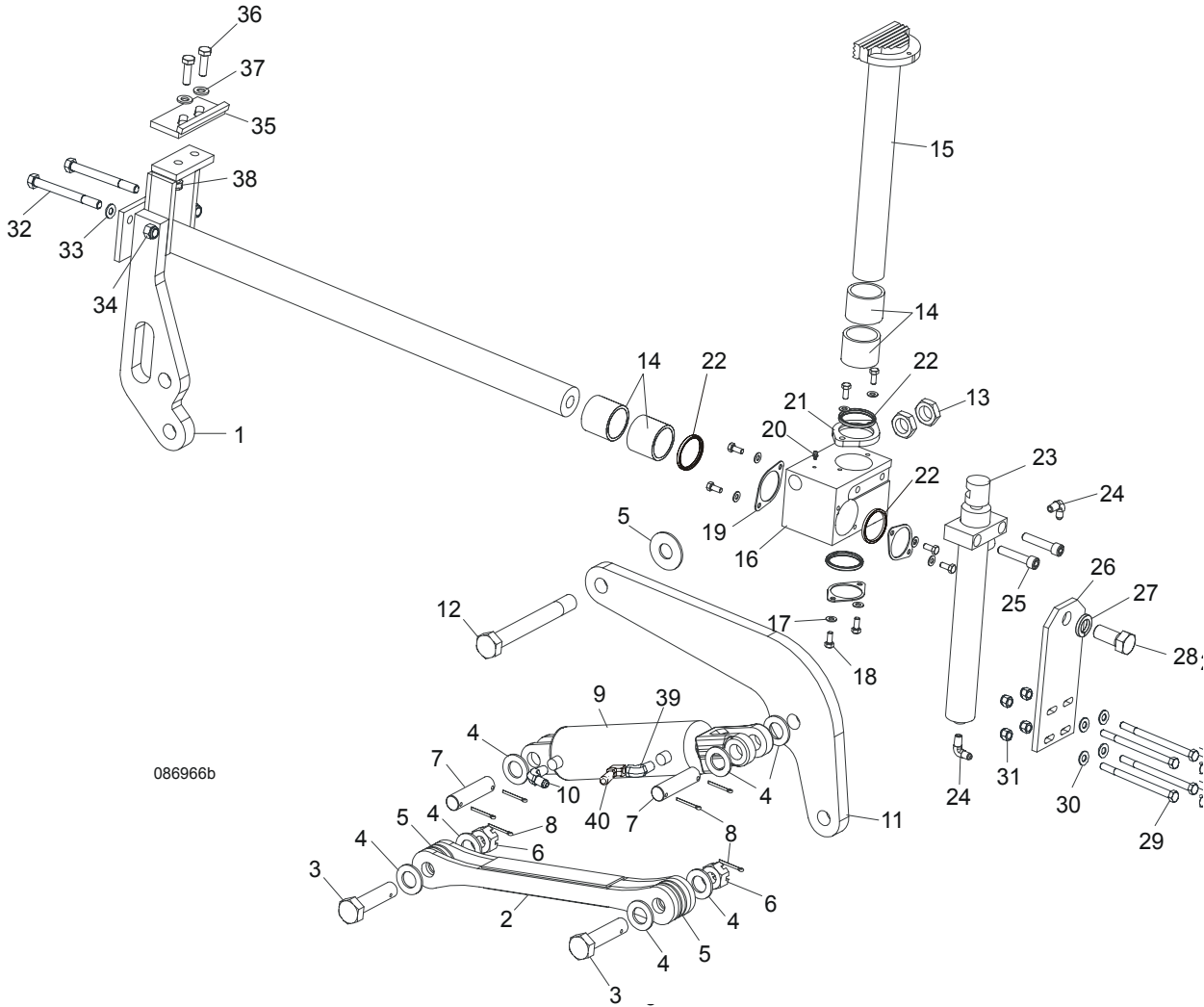

L.P.	OPIS (◆ wskazuje części dostępne jedynie w zespołach)	NUMER KAT.	SZT.
	HYDRAULIC LOG CLAMP ASSEMBLY	088658	1
1	Rod Weldment, Log Clamp Slide Ptd	086967-1	1
2	Arm Weldment, Hydraulic Clamp Link Ptd	086963-1	1
3	Pin, B 24x95/85-Clevis Zinc	F81049-2	1
4	Washer, 25 Flat Zinc	F81061-3	8
5	Washer, 25X63 Zinc-Plated	088585-1	5
6	Nut, Z M20-8-B-Slotted Castle Zinc	F81037-3	2
7	Pin, Hydraulic Cylinder Zinc-Plated	086979-1	2
8	Pin, S-Zn 6,3x45 Cotter	F81045-2	6
9	Cylinder, CJ-S96-16-70/32/178 Hydraulic	088589	1
10	FITTING, 3/8JIC-1/4 NPT STR	015560	1

11	Arm, Hydraulic Log Clamp Link Ptd	086974-1	1	
12	Bolt, M24x217/39 -8.8-B- Hex Head Zinc	088586-1	1	
13	Nut, M24 -04-B- Hex Thin Zinc	F81039-3	2	
14	Bushing, 5040BS Self-Lubricating	088660	2	
15	Rod Weldment, Log Clamp Vertical Painted	088582-1	1	
16	Block, Log Clamp Steel Ptd	088591-1	1	
17	Washer, 8.4 Flat Zinc	F81054-1	8	
18	Bolt, M8x20-8.8-B-Hex Head Full Thread Zinc	F81002-4	8	
19	Flange, Clamp Rod Wiper Ptd	088887-1	3	
20	Fitting, 3/16" Straight Grease	P04107	1	
21	Flange, Clamp Rod Wiper Ptd	088887-1	1	
22	Wiper, ZZ 50x60x7 Log Clamp Rod	088587	1	
23	Cylinder, C,J-S169-16-40/22/254 Hydraulic	088590	1	
24	Fitting, 1/4" NPT - 1/4" JIC Male Elbow	P09142	2	
25	Screw, M12x55 -8.8-B-Hex Socked Head Cap Zinc	F81004-23	2	
26	Plate, Log Clamp Mount Ptd	086975-1	1	
27	Washer, Z 22,5 Split Lock	F81059-4	1	
28	Bolt, M22x1,5x40 -8.8-B-Hex Head Full Thread Zinc	F81009-1	1	
29	Bolt, M10 x 125-8.8 Hex Head Zinc	F81003-18	4	
30	Washer, 10.5 Flat Zinc	F81055-1	8	
31	Nut, M10-8-B Hex Nylon Zinc Lock	F81033-1	4	
32	Bolt, M12x130-8.8-Hex Head Zinc	F81004-36	2	
33	Washer, 13 Flat Zinc	F81056-1	2	
34	Nut, M12-8 Hex Zinc	F81034-1	2	
	STOP KIT, CLAMP	K09485	1	
35	Stop Wldmt, Hydraulic Log Clamp Ptd	086980-1	1	
36	Bolt, M12 x 40 8.8 Hex Head Full Thread Zinc	F81004-4	2	
37	Washer, 13 Flat Zinc	F81056-1	2	
38	NUT, M12-8 HEX NYLON ZINC LOCK	F81034-2	4	
39	FITTING, M/F-90-9/16 JIC ELBOW	500597	1	
40	FITTING, 3/8JIC-1/4NPT 90L	015491	1	

9.10 Hydraulic Toe Board

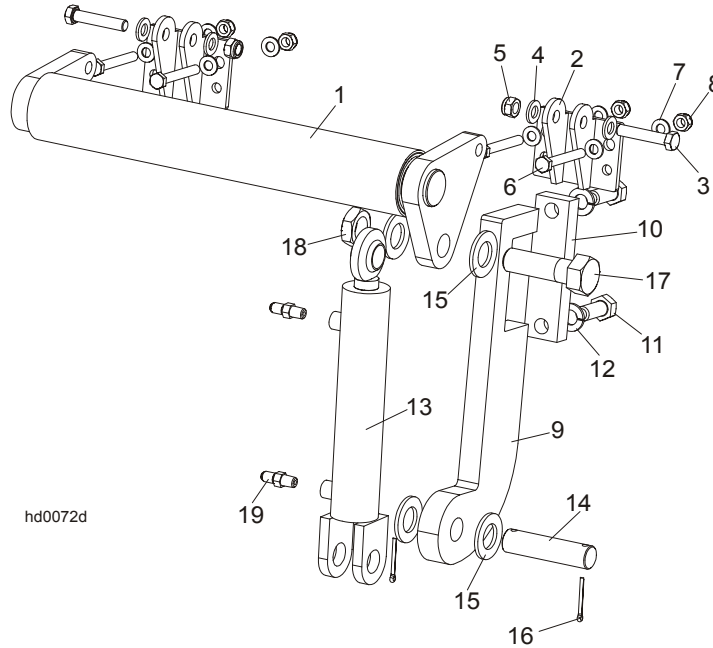

REF	DESCRIPTION (◆ Indicates Parts Available In Assemblies Only)	PART #	QTY.
	HYDRAULIC TOE BOARD - FRONT	092613	1
	HYDRAULIC TOE BOARD - REAR	092634	1
1	Toe Board Weldment, Hydraulic - Front	092612-1	1
1	Toe Board Weldment, Hydraulic - Rear	086253-1	1
2	Bracket, Hydraulic Toe Board	087903-1	2
3	Bolt, M12x60mm Hex Head Zinc Grade 8.8	F81004-5	4
4	Washer, M12 Flat Zinc	F81056-1	8
5	Nut, M12 Hex Nylon Zinc Lock	F81034-2	4
6	Bolt, M10x75-8.8 Hex Head Zinc	F81003-15	8
7	Washer, M10 Flat Zinc	F81055-1	16
8	Nut, M10 Hex Nylon Zinc Lock	F81033-1	8
9	Bracket, Hydraulic Toeboard Mount	087729-1	2
10	Plate, Hydraulic Toeboard Mount	090086-1	2
11	Bolt, M16x40mm Hex Head Full Thread Zinc Grade 5.8	F81006-13	4
12	Washer, 16.3 Split Lock Zinc	F81058-2	4
13	Cylinder, CJ-S170-16-40/25/152 Hydraulic	088681	2
14	Pin, Cylinder Mount	086979-1	2
15	Washer, 28 Flat Zinc	F81061-1	8
16	Pin, 3/16x1.5 Cotter Zinc	F05012-23	4
17	Bolt, 1-8x3 1/4 Hex Head Grade 5	F05009-51	2
18	Nut, 1-14 Hex Jam Unplated	F05010-117	2
19	Fitting, 1/4NPTx1/4JIC Male	P09143	4