

# **LTAGA-PLCBN SHARPENER**

**(Safety, Operation, Maintenance  
& Parts Manual)**

---

**LTAGA-PLCBN rev. D**

---



**Safety is our #1 concern!** Read and understand all safety information and instructions before operating, setting up or maintaining this machine.

*August 2001*

*Form #944*

# Table of Contents

# Section-Page

<b>SECTION 1</b>	<b>SAFETY &amp; GENERAL INFORMATION</b>	<b>1-1</b>
1.1	Electrical Safety.....	1-2
1.2	Blade Handling.....	1-2
1.3	Machine Operation.....	1-3
1.4	Sharpener Components.....	1-4
1.5	Control Panel Components.....	1-5
<b>SECTION 2</b>	<b>SETUP &amp; OPERATION</b>	<b>2-1</b>
2.1	Blade Support Installation.....	2-1
2.2	Blade Rest Bolt Location.....	2-2
2.3	Sharpener Head Angle Adjustment.....	2-3
2.4	Sharpener Alignment.....	2-5
2.5	Grinding Wheel Installation.....	2-7
2.6	Blade Installation.....	2-8
2.7	Face Grind Adjustment.....	2-11
2.8	Depth Grind Adjustment.....	2-12
2.9	Oil Flow Adjustment.....	2-14
2.10	Feed Rate Adjustment.....	2-14
2.11	Magnetic Shut-off.....	2-15
2.12	Blade Rejection.....	2-15
2.13	Operation Overview.....	2-16
2.14	Shutoff.....	2-16
<b>SECTION 3</b>	<b>MAINTENANCE</b>	<b>3-1</b>
3.1	Grinding Wheel Replacement.....	3-1
3.2	Oil Level.....	3-1
<b>SECTION 4</b>	<b>MAINTENANCE &amp; TROUBLESHOOTING</b>	<b>4-1</b>
4.1	Sharpener Maintenance.....	4-1
4.2	Blade Sharpening Tips.....	4-2
<b>SECTION 5</b>	<b>ALIGNMENT</b>	<b>5-1</b>

# Table of Contents

# Section-Page

<b>SECTION 6</b>	<b>REPLACEMENT PARTS</b>	<b>6-1</b>
6.1	How To Use The Parts List .....	6-1
6.2	Blade Support Assembly .....	6-2
6.3	Grinder Assembly.....	6-3
6.4	Sharpener Mounting Plate and Blade Clamp Assembly .....	6-5
6.5	Oil Pump/Pan.....	6-6
6.6	Cam Assembly.....	6-7
6.7	Cover Assembly .....	6-9
6.8	Angled template.....	6-10
6.9	Alignment tool.....	6-11
<b>SECTION 7</b>	<b>ELECTRICAL INFORMATION</b>	<b>7-1</b>
7.1	Electrical Symbol Diagram .....	7-1
7.2	Electrical Component List.....	7-2
7.3	Component Layout Diagram .....	7-2

## SECTION 1 SAFETY & GENERAL INFORMATION



This symbol calls your attention to instructions concerning your personal safety. Be sure to observe and follow these instructions. This symbol accompanies a signal word. The word **DANGER** indicates an imminently hazardous situation which, if not avoided, will result in death or serious injury. **WARNING** suggests a potentially hazardous situation which, if not avoided, could result in death or serious injury. **CAUTION** refers to potentially hazardous situations which, if not avoided, may result in minor or moderate injury to persons or equipment. Read all safety instructions before operating this equipment and observe all safety warnings!



Warning stripes are placed on areas where a single decal would be insufficient. To avoid serious injury, keep out of the path of any equipment marked with warning stripes.

Read and observe all safety instructions before operating this equipment! Also read any additional manufacturer's manuals and observe any applicable safety instructions including dangers, warnings, and cautions.

Always be sure that all safety decals are clean and readable. Replace all damaged safety decals to prevent personal injury or damage to the equipment. Contact your local distributor, or call your Customer Service Representative to order more decals.

Always properly dispose of all by-products, including debris, coolant and oil.

Safety instructions are listed in this section by the following operations:

- Electrical Safety
- Blade Handling
- Machine Operation

## 1.1 Electrical Safety



**DANGER!** Make sure all electrical installation, service and/or maintenance work is performed by a qualified electrician and is in accordance with applicable electrical codes.

**DANGER!** HAZARDOUS VOLTAGE can cause shock, burns, or death. SHUT OFF & LOCK OUT POWER before performing service in any area of this machine. DO NOT restore power until all access panels are replaced and secured.



**WARNING!** Always turn off and disconnect power at control console AND at main supply circuit breaker before performing any service to the machine.

## 1.2 Blade Handling



**WARNING!** Always wear gloves and eye protection when handling bandsaw blades. Keep all persons away from area when coiling or carrying a blade.

### 1.3 Machine Operation



**DANGER!** Make sure all guards and covers are in place and secured before operating the sharpener. Failure to do so may result in serious injury.

**DANGER!** Keep all persons away from moving parts when operating this machine. Failing to do so will result in serious injury.

**DANGER!** Always keep hands away from moving bandsaw blade. Failure to do so will result in serious injury.



**WARNING!** Always wear eye, ear, respiration, and foot protection when operating this machine. Failure to do so may result in serious injury.

**WARNING!** Secure all loose clothing and jewelry before operating this machine. Failure to do so may result in serious injury or death.

## 1.4 Sharpener Components

Patrz rysunek 1-1. The major components of the sharpener are shown below.

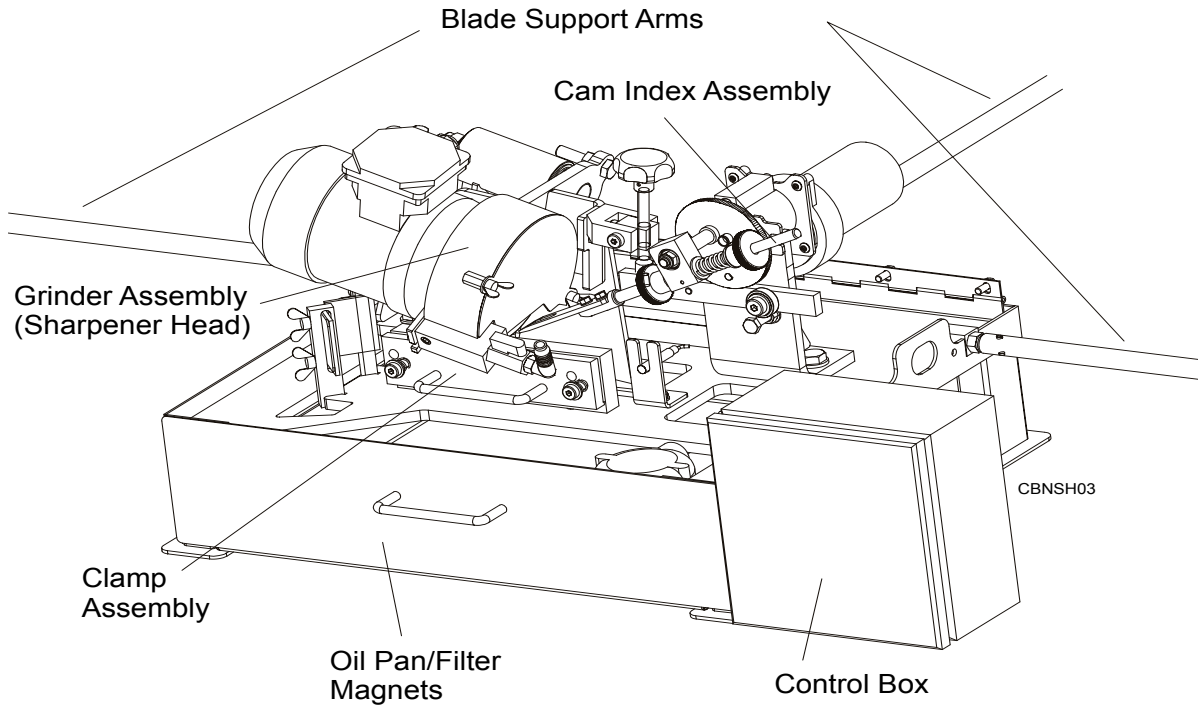

RYS. 1-1

## 1.5 Control Panel Components

Patrz rysunek 1-2. The control panel components and their descriptions are shown below.

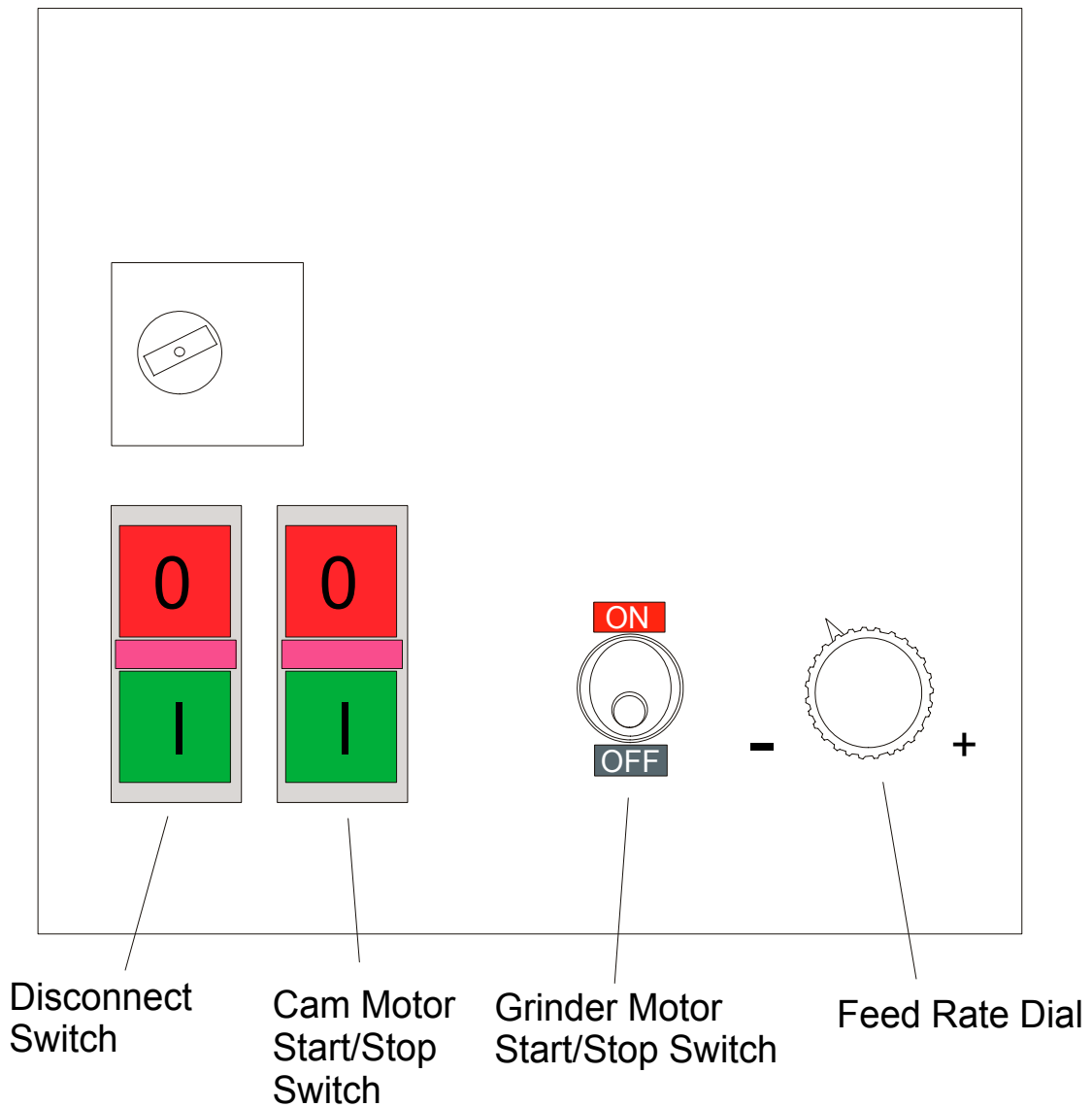

**RYS. 1-2**



- **Disconnect switch**

*Turns on/off the sharpener power and the oil pump.*

Turn switch to the "0", or vertical, position to lock out all electrical power during service or when equipment is not in use. NOTE: The Disconnect Switch must be in the "0" position before the control box door can be opened.

To reconnect power to equipment, turn switch to the "1", or horizontal, position.

- **Feed Rate Dial**

*Controls cam speed.*

Rotate dial as necessary to increase or decrease cam speed.

- **Grinder Motor Start/Stop Switch**  
**Starts/Stops grinder motor.**

- **Cam Motor Start/Stop Switch**

Press the Cam Motor Start Switch to start the cam motor. NOTE: Place the Feed Rate Dial in the "0" position before starting the cam motor.

Press the Cam Motor Stop Switch to turn the cam motor off and unclamp the blade.

## SECTION 2 SETUP & OPERATION

### 2.1 Blade Support Installation

The sharpener includes three blade support arms with guide assemblies.

To install the support arms, lubricate the threaded ends of the arms with grease. Insert one arm into the threaded holes on each side of the sharpener.

1. Each guide assembly consists of a blade support with post, a blade support without post, two bolts, a self-locking nut, and a wing nut.

**See Figure 2-1.** To install the guides, join one guide assembly around the end of each blade support arm. Face the post outward as shown. Bolt from the hexed side of the guide assembly (these hex-shaped holes will keep the bolts from turning once in place). Secure the top bolt with a self-locking nut. Secure the bottom bolt with a wing nut.

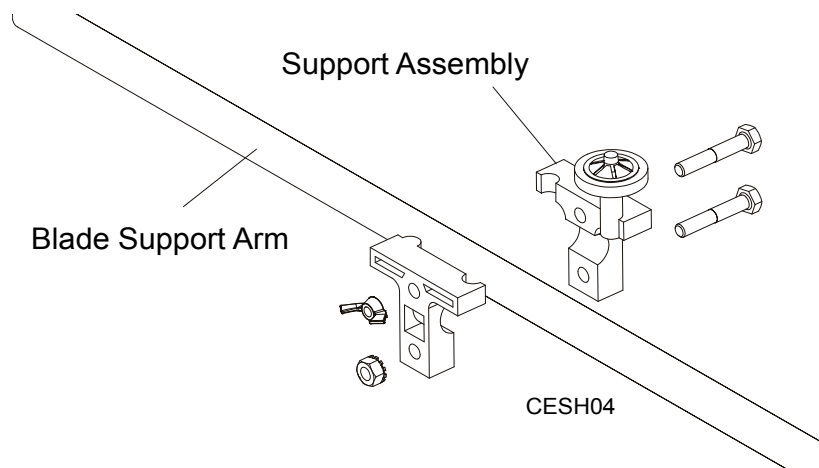

2. Tilt the guides on the left blade support arm slightly backward, toward the rear of the sharpener. Tilt the guides on the right support arm slightly forward, toward the front of the sharpener.

**2.2 Blade Rest Bolt Location**

The blade rests on two blade rest bolts mounted in the blade clamp plates. The bolts insert into any of the clamp plates' three sets of holes. Place the blade rest bolts in the top set of holes to sharpen 1" blades, the middle set to sharpen 1 1/4" blades, and the bottom set to sharpen 1 1/2" blades. To change bolt location, unscrew the blade rest bolts, remove them from one set of holes and reinstall to desired set of holes. Tighten the blade rest bolts.

**See Figure 2-2.**

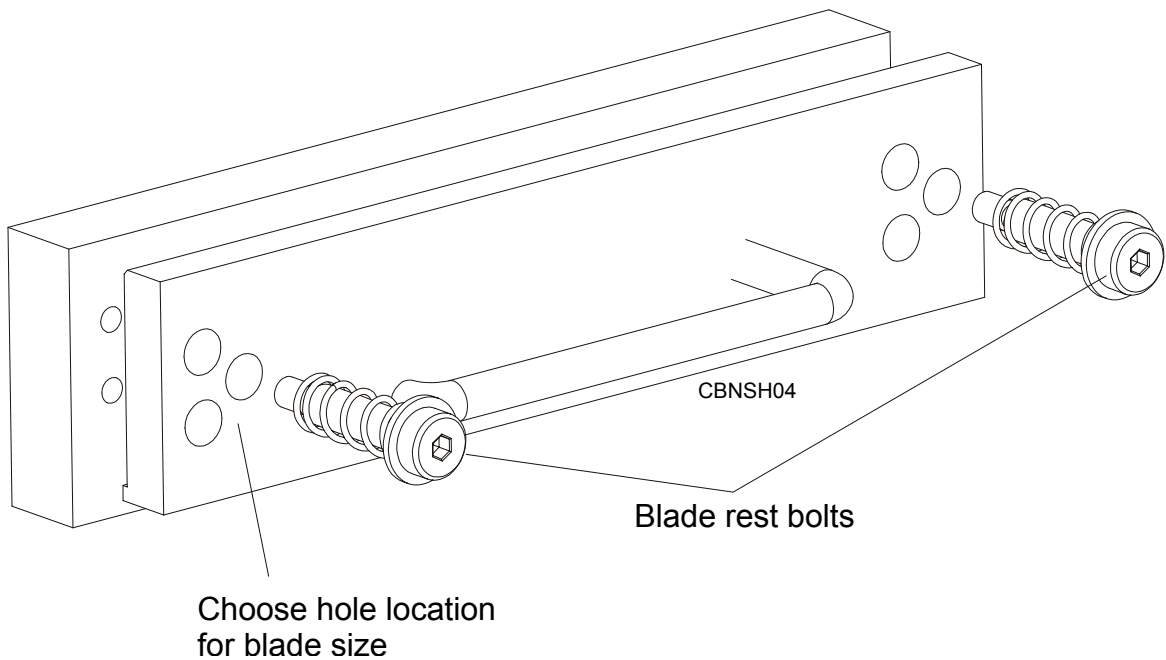

**FIG. 2-2**

**NOTE:** After installing the blade rest bolts, flex the blade support arms up or down as necessary so the blade will remain level around the complete length of the blade.

## 2.3 Sharpener Head Angle Adjustment

An angled template, which includes angle for 15 degrees, is provided to check hook angle.

**Note:** Refer to the Wood-Mizer Blade Handbook for recommended hook angle specifications for your sawing application.

**See Figure 2-3.** To adjust sharpener, place the provided template against the grinding wheel face. Loosen the depth/back adjustment knob until the template rests on the fixed clamp plate.

**See Figure 2-4.** Next, loosen the sharpener head mounting bolt and nut in the motor mounting bracket. Loosen stop bolt and its jam nut. Tilt the sharpener head until you reach the desired angle. Hold the sharpener head in place while retightening the sharpener head mounting bolt and nut. Tighten the stop bolt and secure it with the jam nut.

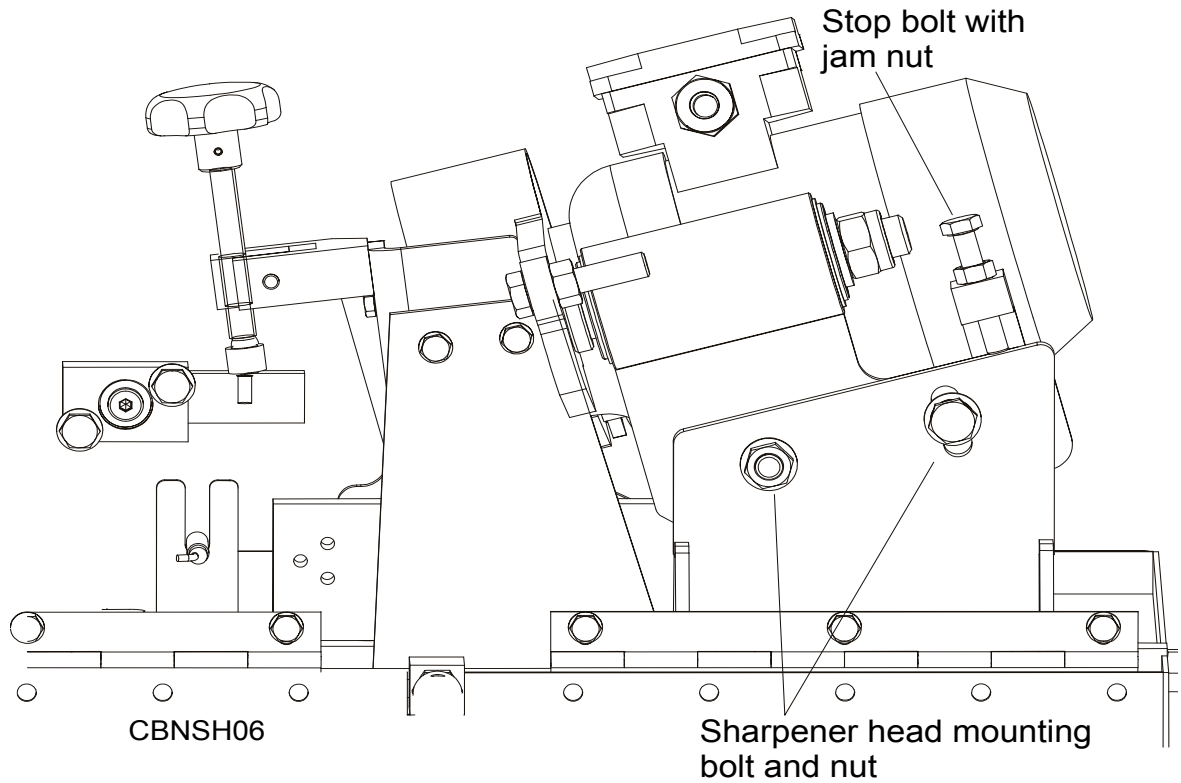

**FIG. 2-4**

## 2 SETUP & OPERATION

### Sharpener Alignment

#### 2.4 Sharpener Alignment

Use the provided LTAGA-PLCBN sharpener alignment tool as necessary to achieve accurate alignment between the blade clamp and the grinding wheel.

**IMPORTANT!** Do not adjust the alignment tool bolts. They have been pre-calibrated at the factory to ensure accurate alignment results.

1. **IMPORTANT!** Make sure the grinder motor is OFF. Cycle the cam until the grinding wheel is at the tip of the tooth (about to begin face grind).
2. Remove the grinding wheel cover and sharpener arbor nut. Remove the grinding wheel.
3. Remove the blade rest bolts and moving clamp plate.
4. Install the alignment tool to the grinder motor shaft as shown below.

**See Figure 2-5.** Position the tool so all three gauge points are in line with the front clamp plate. Secure the tool in position with the sharpener arbor nut.

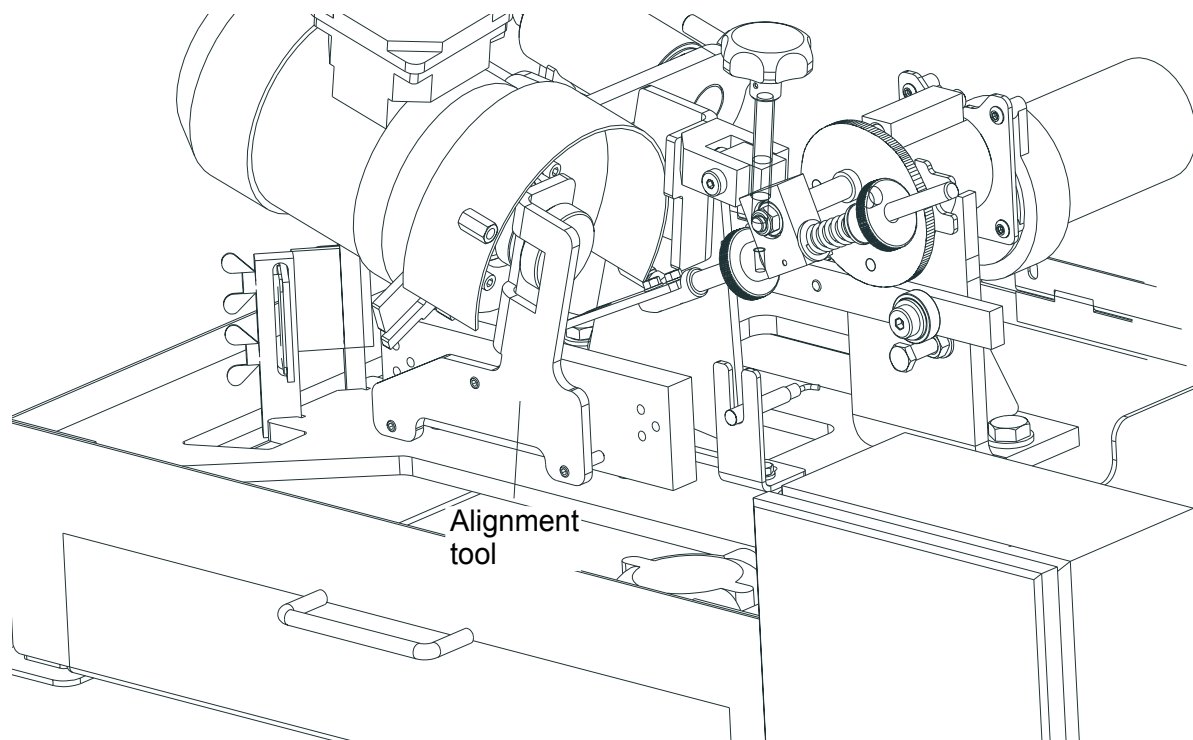
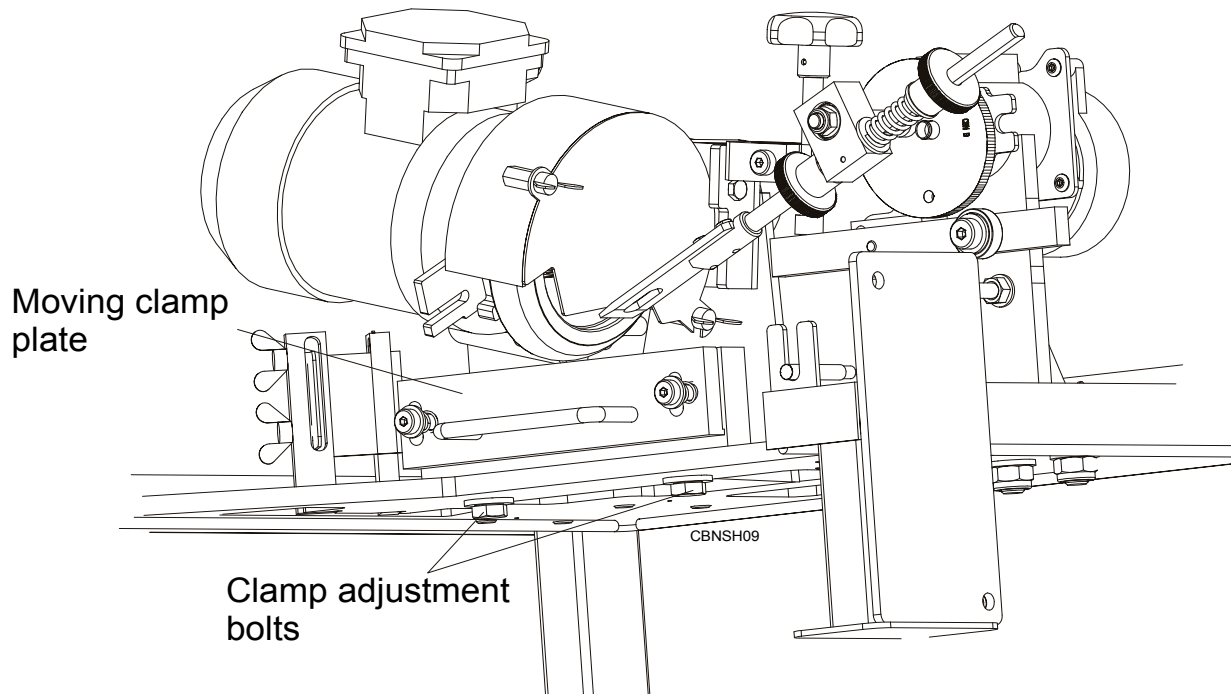

FIG. 2-5

5. Loosen the clamp adjustment bolts.
6. Position the clamp assembly so the front clamp plate touches all three tool gauge points. Secure in position by tightening the clamp adjustment bolts.

**See Figure 2-6.**



**FIG. 2-6**

7. Remove the arbor nut and alignment tool.
8. Reinstall the moving clamp plate.
9. Reinstall the grinding wheel and secure in place with the arbor nut.
10. Reinstall the grinding wheel cover.

## 2.5 Grinding Wheel Installation

Use a Wood-Mizer approved grinding wheel. To install:

1. Push the START button on the control box and turn the FEED RATE dial up to rotate the cam.
2. Rotate the cam until the sharpener head is at its highest setting. Turn the FEED RATE all the way down and push the STOP button.
3. Remove the grinding wheel cover.
4. Remove the oiler.
5. Remove the arbor nut.
6. Slide a grinding wheel onto the motor shaft.
7. Reinstall the arbor nut and hand tighten. Reinstall the grinding wheel cover and oiler.



**DANGER!** Make sure all guards and covers are in place and secured before operating the sharpener. Failure to do so may result in serious injury.

8. If the installed grinding wheel is running out axially, unscrew the arbor nut, turn the grinding wheel about 15 degrees and replace the arbor nut. Then check the grinding wheel's rotation. If the axial runout is still present, perform the above-mentioned steps again. Repeat them as necessary until the problem is corrected.
9. After installing and adjusting the grinding wheel, hold the sharpener head up with your hand and turn the back/depth grind knob until you can lower the head and the grinding wheel will not contact the blade. Carefully lower the sharpener head.



## 2.6 Blade Installation

See **Figure 2-7**. Before installing a blade, push the cam motor START switch and turn the FEED RATE dial until the cam pivot bolt is at the 2 o'clock position.

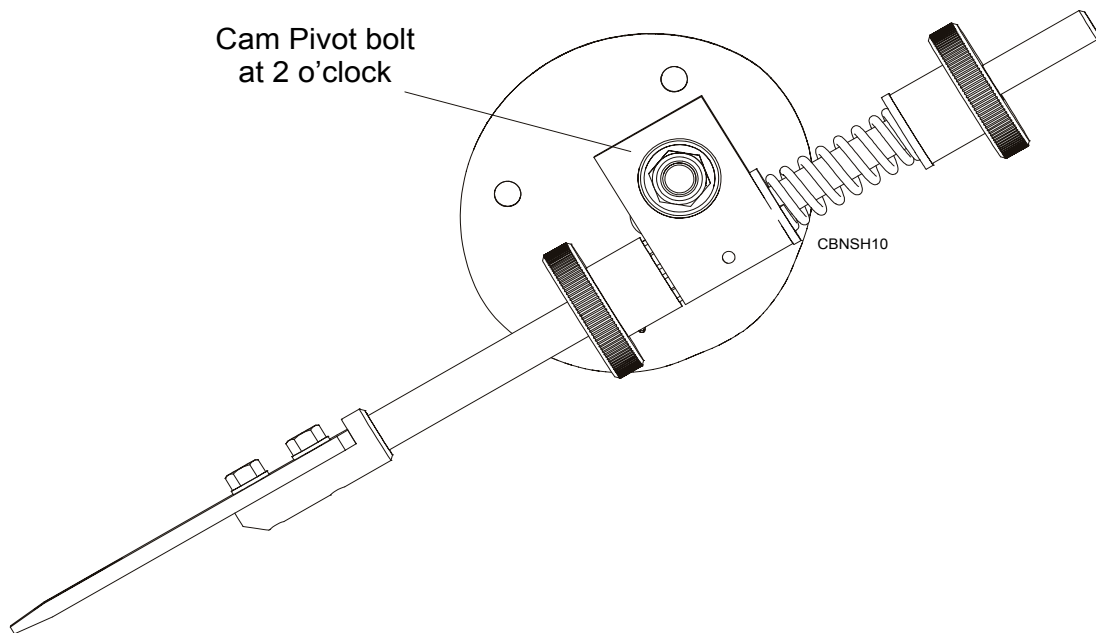

**FIG. 2-7**

Uncoil a blade and position above the three support assemblies around the sharpener. Check to be sure the teeth on the portion of blade that will be under the grinding wheel point to the right as you face the sharpener. If not, remove the blade and invert it.

## 2 SETUP & OPERATION

### Blade Installation

See Figure 2-8. Position the blade inside the left and rear blade support posts.

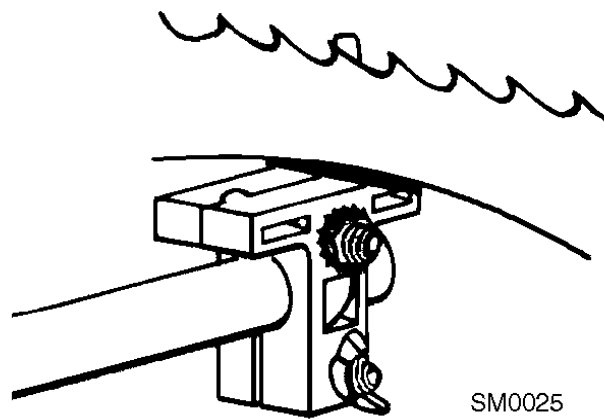

FIG. 2-8

See Figure 2-9. Position the blade outside the right blade guide wheel.

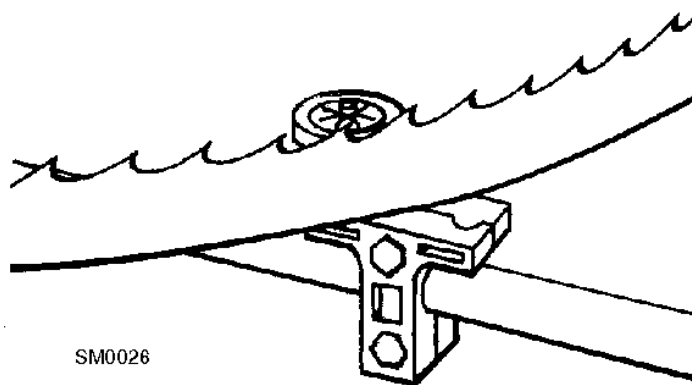

FIG. 2-9

Holding the blade with your left hand, lift the sharpener head. Then raise and hold the indexing arm up, loosen the blade clamping fixture and press the blade between the clamping plates. Lower the indexing arm and the sharpener head.

Make final adjustments to the blade support arms and guide assemblies. Make sure the blade band rests evenly on both blade rest bolts. The blade should not touch the bottom of either side guide assembly. All three guide assemblies should lean slightly in the direction the blade travels through them.

Bend the blade wiper on the left side of the sharpener so that it touches the blade. The wiper will wipe coolant from the blade into the oil pan so it does not drip on the floor.

## 2 SETUP & OPERATION

### Face Grind Adjustment

#### 2.7 Face Grind Adjustment

As you operate the sharpener, the cam will rotate causing the index arm to contact a tooth and push it to a position under the grinding wheel. The index arm can be adjusted to leave the tooth closer to or further from the grinding wheel so the tooth face is ground lighter or heavier.

1. Before adjusting the face grind, make sure the cam and grinder motors are off, the feed rate dial is set at "0" and the Sharpener head is raised.
2. Install the blade.
3. Turn on the cam motor and slowly increase the FEED RATE until the next tooth is underneath the grinding wheel.
4. Lower the Sharpener head and check to make sure the grinding wheel lightly contacts the entire face of the tooth all the way up to the tip.

**See Figure 2-10.** If the face grind is too light, turn the face grind adjustment knob out away from the other knob. If the face grind is too heavy, turn the adjustment knob in toward the other knob.

5. Recheck the face grind on the next tooth and adjust as needed.

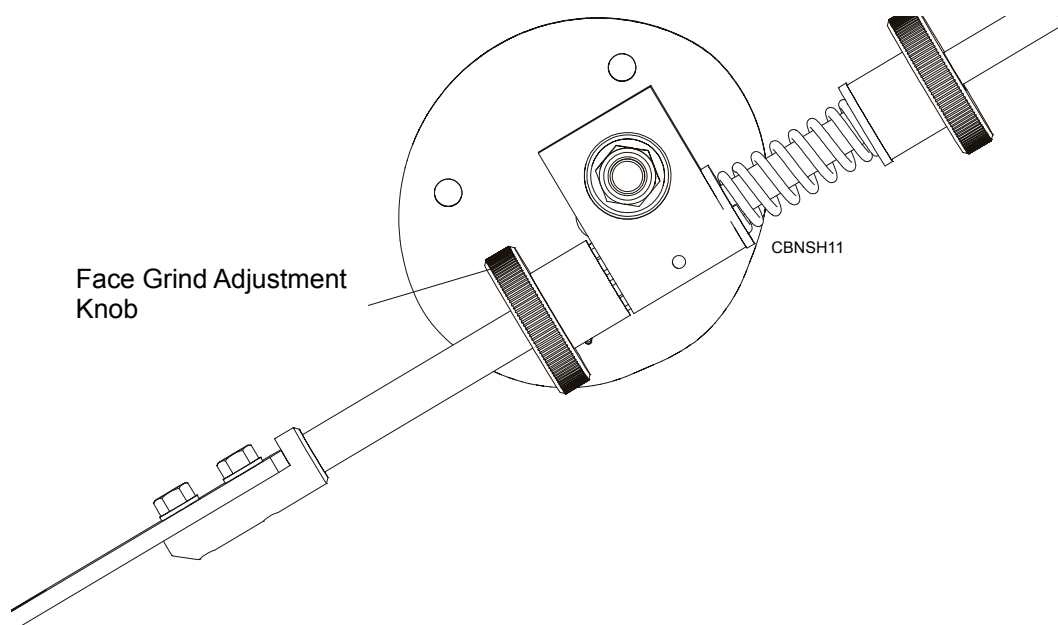
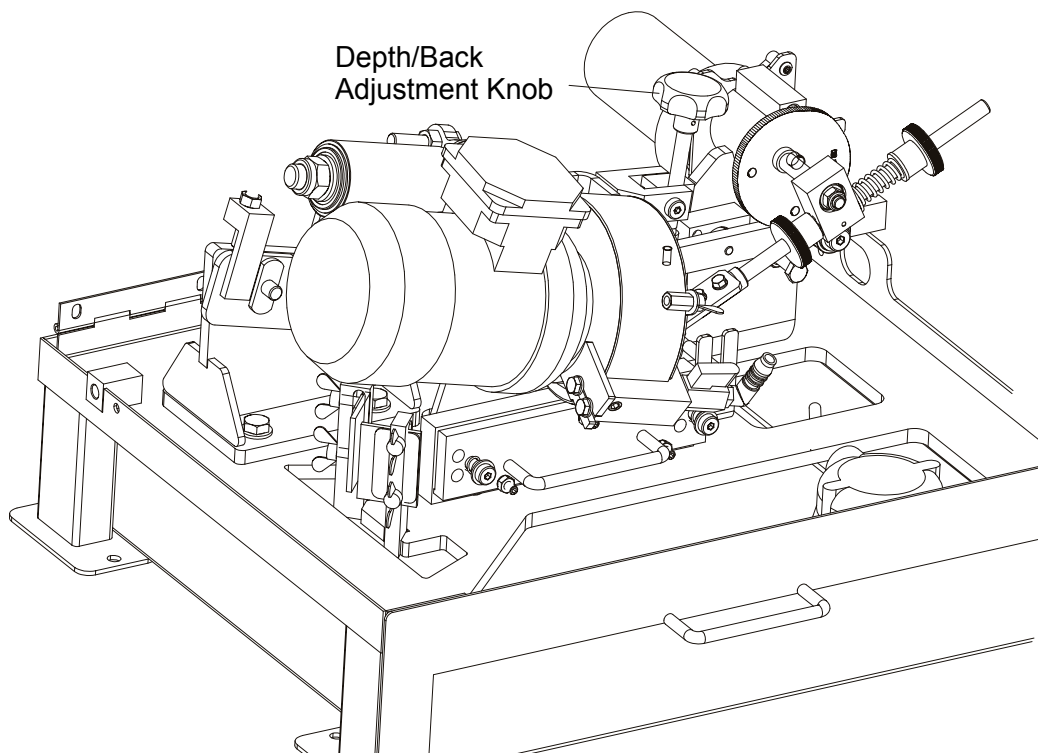

FIG. 2-10

## 2.8 Depth Grind Adjustment

Tooth height is determined by how much material is removed from the gullet of the blade. The depth/back grind knob controls how far the grinding head comes down and therefore controls the gullet grind.

1. With the feed rate at "0", turn on the cam and grinder motors.
2. Turn up the feed rate and check the depth grind. The grinding wheel should lightly touch the gullet of the blade and you should see clean metal across the entire gullet of the sharpened tooth.
3. If adjustment is needed, turn the depth stop knob. Turn the knob in to lower the head, out to raise the head.



**FIG. 2-11**

4. Recheck the depth grind.
5. Check the depth grind two to three times during the blade sharpening. Make sure you see clean metal across the entire gullet of sharpened teeth each time. If you do not see clean metal, stop the sharpener and adjust the depth grind as necessary.

**IMPORTANT!** After any adjustment, always restart the blade and sharpen in its entirety to ensure symmetry.

**NOTE:** Depth grind may be affected as the grinding wheel passes over blade welds.

---

## 2.9 Oil Flow Adjustment

To activate blade oiling, open the oil flow control valve located on the oiler.

## 2.10 Feed Rate Adjustment

The Feed Rate Dial controls cam speed. During the sharpening cycle, adjust cam speed to have as fast of a feed rate as possible without "burning" the blade.

**NOTE:** All machines should be adjusted by maintenance to a maximum speed of 60 revolutions per minute. [See Section 4.2.](#)

## 2 SETUP & OPERATION

### Magnetic Shut-off

#### 2.11 Magnetic Shut-off

See Figure 2-12. The shut-off sensor is located to the right of the blade clamp assembly. When passed over by a magnet, it automatically shuts down the grinder and cam motors.

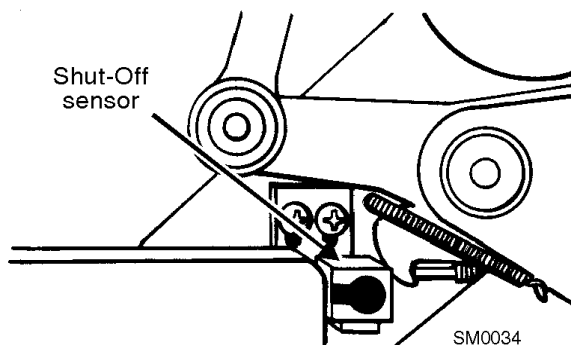

FIG. 2-12

To install, take an orange-painted magnet from the bag assembly. Place the black side of the magnet against the bottom edge of the blade on the inside of the tenth face-ground tooth. After the sensor bracket has shut off the cam and grinder motors, flip the grinder switch into the off position. Remove the magnet.

#### 2.12 Blade Rejection

Sometimes blades cannot be resharpened. Reasons to reject blades for resharpening include:

- the blade is coil set (the blade is over-stressed and will fold on itself),
- the blade is missing 2 or 3 teeth or more in a row,
- the blade band has been twisted,
- the blade band is too low for the grinder (the blade has been sharpened too many times/too much material has already been ground from the blade),
- the blade has no set on one of its sides,
- severe rust is present,
- or the blade has tooth spacing uncommon to Wood-Mizer blades (i.e., a competitor's blade).



## 2.13 Operation Overview

Use the following steps to guide you through sharpener operation.

1. Adjust the blade clamp for the blade you will be sharpening.
2. Install a grinding wheel if necessary, then install the blade.
3. Adjust face grind and depth grind.
4. Activate the oil flow.
5. Increase the feed rate to a moderate speed. How fast you can grind will be determined by how much material you are removing from the blade. If a heavy grind is required, it is best to go around the blade lightly twice rather than try to grind heavily once.
6. After about ten teeth have been ground, mount the orange-painted magnet right behind the blade wiper. (See Section 2.11.)
7. Check the depth grind two to three times during the blade sharpening. Adjust as necessary.

**IMPORTANT!** After any adjustment, always restart the blade and sharpen in its entirety to ensure symmetry.

## 2.14 Shutoff

The sharpener will automatically shutoff when blade has been entirely sharpened.

Inspect the blade. Repeat sharpening process if necessary. Blades with a bad profile or those which are badly in need of sharpening may have to be ground more than once.

## **SECTION 3 MAINTENANCE**

### **3.1 Grinding Wheel Replacement**

Check the grinding wheel often and change as necessary. Wheels approved for use with the sharpener are available from Wood-Mizer.

The grinding wheel should be in good condition. Replace if worn, the edges look shiny, and/or the wheel is "burning" the blades. **NOTE:** The grinding wheels have a CBN (Cubic Boron Nitride) coating. If this is not worn through and there is no damage to the wheels, the wheels can be replated approximately three to four times.

1. To replace, shut down and lock out all power to the machine.
2. Remove the grinding wheel cover.
3. Remove the grinding wheel nut, washer plate and grinding wheel.
4. Install the new grinding wheel. Reinstall the washer plate and nut.
5. Reinstall the grinding wheel cover.

### **3.2 Oil Level**

Periodically check the oil level and refill with oil as necessary. The oil level should be kept between 4.5 and 5 litres. Use only Wood-Mizer approved grinding oil.

Filter the oil to remove metal shavings before reusing.

---

## SECTION 4 MAINTENANCE & TROUBLESHOOTING

### 4.1 Sharpener Maintenance

- Wipe the sharpener dry after each day's use.
- Keep clean of dirt, rust, and metal filings.
- Remove the clamp regularly and clean out any buildup that might cause it to not clamp the blade firmly. To do so, unscrew the blade rest bolts and remove the moving clamp plate.
- Clean sediment from the oil pan and filter magnets as needed.

## 4.2 Blade Sharpening Tips

This section covers some of the common problem areas of blade sharpening.

Before removing from the saw, clean the blade by running the waterlube on the blade for 15 seconds. This will remove most of the sap buildup that would otherwise have to be scraped off when it dries. Wipe with a clean dry rag.

Make sure the flow of oil through the oiler assembly is strong.

Sharpen the blade when it first shows signs of dullness. If the blade is extremely dull, due to hitting a rock or some form of foreign matter, sharpen the blade twice lightly, instead of trying to remove too much in one grind. Grinding too much material at once may cause the circuit breaker in the control box to kick out. If this happens, wait 15 seconds. Then turn it on (push circuit breaker down).

## SECTION 5 ALIGNMENT

Align the sharpener monthly to ensure quality performance. Also realign the sharpener as necessary (i.e., after the grinding wheel has been impacted by the index pawl).

## SECTION 6 REPLACEMENT PARTS

### 6.1 How To Use The Parts List

- Use the table of contents or index to locate the assembly that contains the part you need.
- Go to the appropriate section and locate the part in the illustration.
- Use the number pointing to the part to locate the correct part number and description in the table.
- Parts shown indented under another part are included with that part.
- Parts marked with a diamond (◆) are only available in the assembly listed above the part.

See the sample table below. Sample Part #A01111 includes part F02222-2 and subassembly A03333. Subassembly A03333 includes part S04444-4 and subassembly K05555. The diamond (◆) indicates that S04444-4 is not available except in subassembly A03333. Subassembly K05555 includes parts M06666 and F07777-77. The diamond (◆) indicates M06666 is not available except in subassembly K05555.

<b>Sample Assembly</b>				
REF	DESCRIPTION (◆ Indicates Parts Available In Assemblies Only)	PART #	QTY.	
	<b>SAMPLE ASSEMBLY, COMPLETE (INCLUDES ALL INDENTED PARTS BELOW)</b>	A01111	1	
1	Sample Part	F02222-22	1	
	Sample Subassembly (Includes All Indented Parts Below)	A03333	1	
2	Sample Part (◆ Indicates Part Is Only Available With A03333)	S04444-4	1	◆
	Sample Subassembly (Includes All Indented Parts Below)	K05555	1	
3	Sample Part (◆ Indicates Part Is Only Available With K05555)	M06666	2	◆
4	Sample Part	F07777-77	1	

#### To Order Parts:

- From Europe call our European Headquarters and Manufacturing Facility in Kolo, Poland at **+48-63-2610233**. From the continental U.S., call our toll-free Parts hotline at **1-800-448-7881**. Have your customer number, vehicle identification number, and part numbers ready when you call.
- From other international locations, contact the Wood-Mizer distributor in your area for parts.

## 6.2 Blade Support Assembly

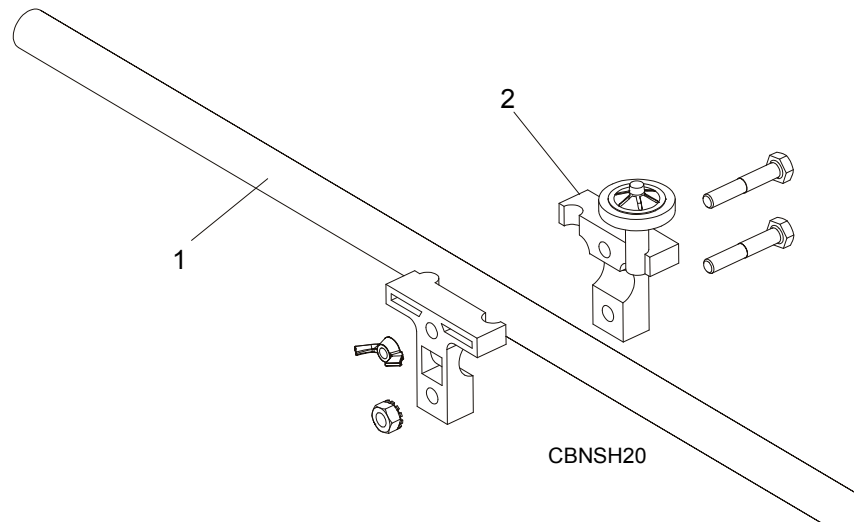

REF	DESCRIPTION (◆ Indicates Parts Available In Assemblies Only)	PART #	QTY.	
1	<b>BLADE SUPPORT ASSEMBLY, COMPLETE</b>	087518-1	3	
1	GUIDE KIT, BLADE SUPPORT	A10617	1	

### 6.3 Grinder Assembly

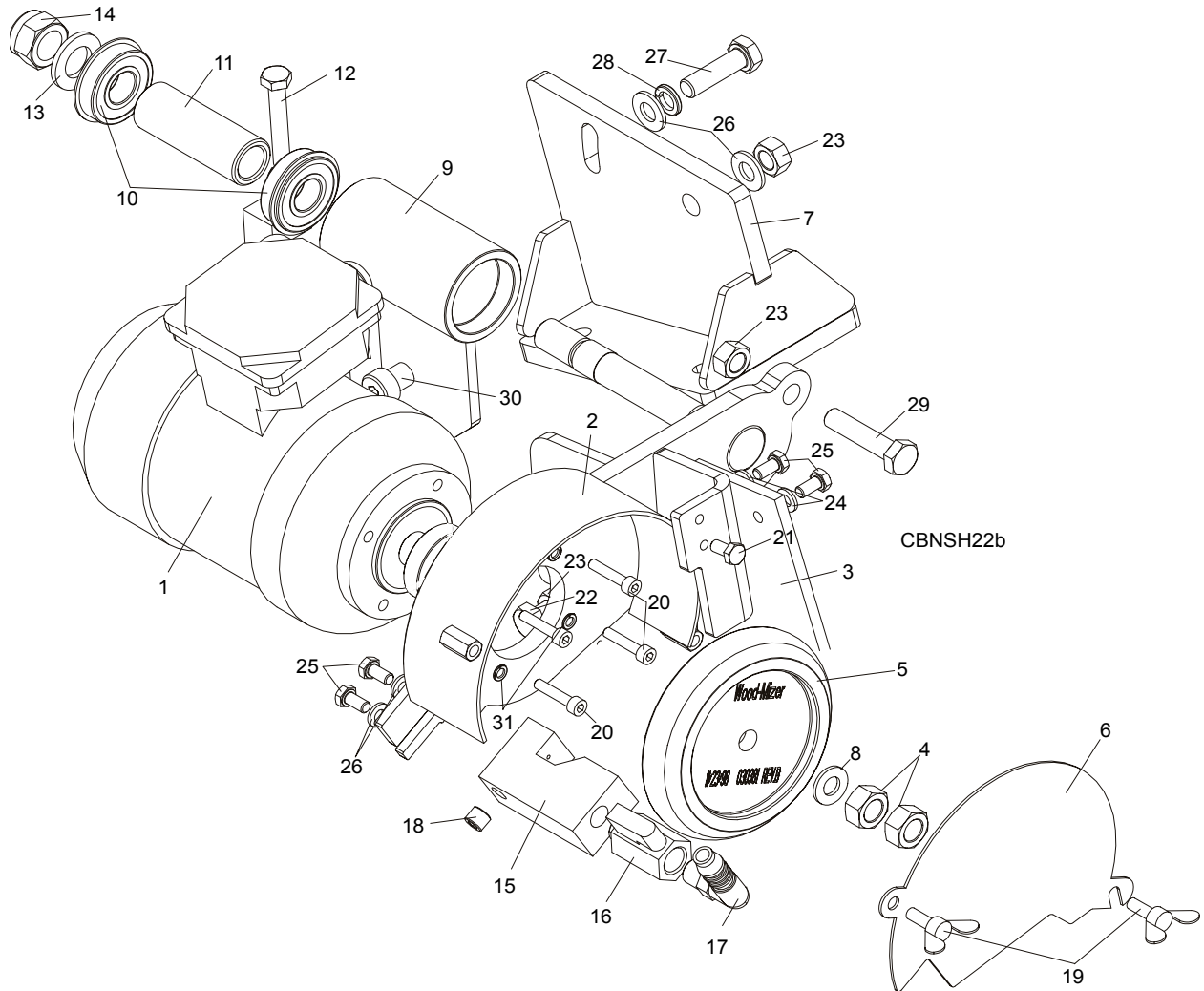

REF	DESCRIPTION (◆ Indicates Parts Available In Assemblies Only)	PART #	QTY.
	<b>SHARPENER HEAD, COMPLETE</b>	088220	1
1	Motor, SEKg56 2C2	089378	1
2	Head Weldment	088219-1	1
3	Guard, Oil Splash	087858	1
4	Nut, M8-8-B-Fe/Zn5	F81032-1	1
5	Grinding Wheel, CBN	030381	1
6	Cover, Front Guard	088247-1	1
7	Base Weldment, Sharpener Head	088400-1	1
8	Washer 8,4-Fe/Zn5	F81054-1	2
9	Bushing, Sharpener Vertical Pivot	088339-1	1
10	Bearing w/Ring	086395	2
11	Bushing, Bearing Spacer	086719	1
12	Bolt, M8x50 - 8.8	F81002-19	1
13	Washer, 17 Flat	F81058-1	1



14	Nut, M16-8	F81036-2	1	
15	Oiler	088239	1	
16	Valve, FP60.KIT 28 G1/4 Oil Flow Control	088380	1	
17	Stud, WES 10/R 1/4 Elbow	088379	1	
18	Plug, M10x1 DIN 906 BN40 Bossard	F81015-3	1	
19	Screw, M6x16 DIN 316 Thumb	F81001-16	2	
20	Screw, M5x25 -8.8 Hexagon Socket Head Cap	F81000-7	4	
21	Bolt, M6 x 12 8.8 Hex Head	088380	1	
22	Bolt, M10x70 - 8.8 Hex Head	F81003-20	1	
23	Nut, M10 -8-B Hex	F81033-3	3	
24	Washer, 6.4	F81053-1	4	
25	Bolt, M6x12 - 8.8 Hex Head	F81001-7	5	
26	Washer, 10.5 Flat	F81055-1	2	
27	Bolt, M10x35 - 8.8 Hex Head	F81003-17	1	
28	Washer, 10.2 Split Lock	F81055-2	1	
29	Bolt, M10x45 - 8.8 Hex Head	F81003-3	1	
30	Screw, 12/M10x16 12.9 Bossard Socket Head Shoulder	F81003-64	1	
31	Washer, 5.1 Split Lock	F81052-2	4	

# 6

## Replacement Parts Sharpener Mounting Plate and Blade Clamp Assembly

### 6.4 Sharpener Mounting Plate and Blade Clamp Assembly

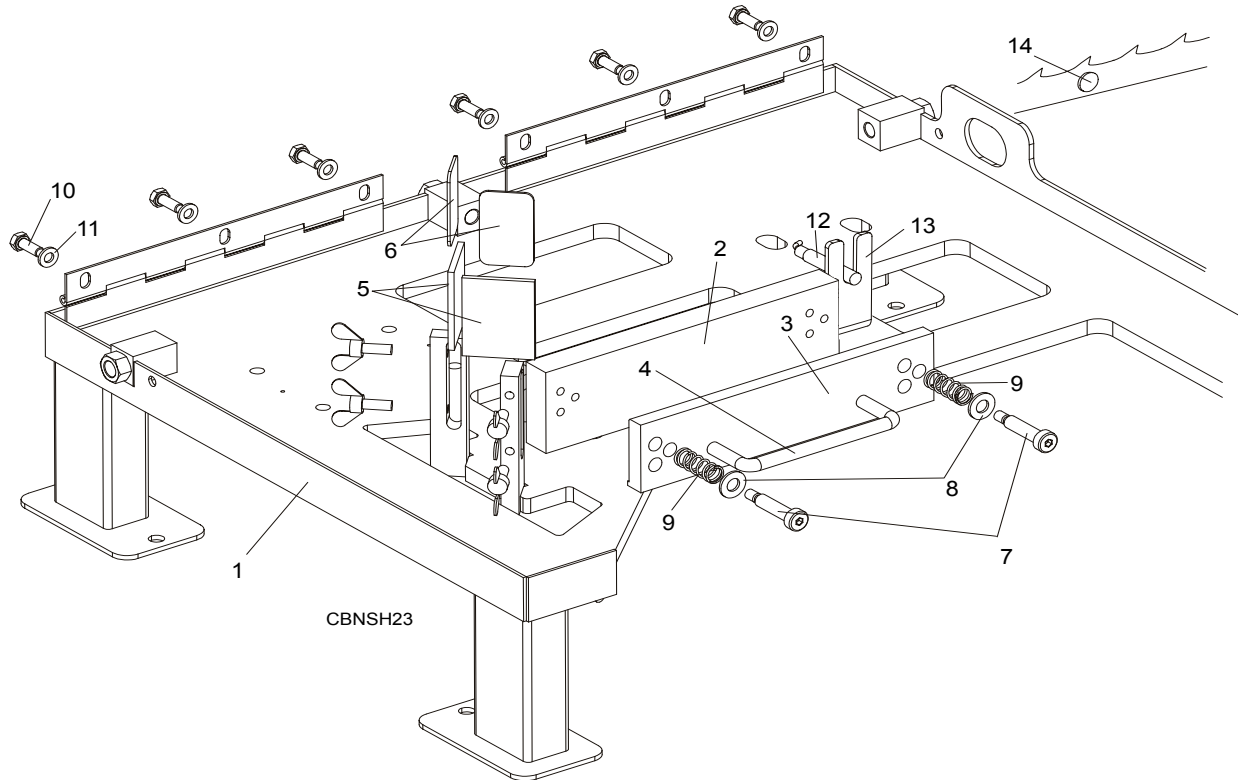

REF	DESCRIPTION (◆ Indicates Parts Available In Assemblies Only)	PART #	QTY.	
1	PLATE SHARPENER MOUNTING	088198-1	1	
2	PLATE, FIXED CLAMP	088235-1	1	
3	PLATE, MOVING CLAMP	088236-1	1	
4	Handle w/Bolts	P08065	1	
5	WIPER, FLEXAM 3T2862 BLADE	087608	2	
6	BRACE, BLADE WIPER	088098-1	2	
7	SCREW, 8/M6X30-12.9 SOCKET HEAD SHOULDER	F081001-18	2	
8	WASHER, 8.4 FLAT	F81054-1	2	
9	SPRING, 9X30X1.2 COMPRESSION	088368	2	
10	BOLT, M6X16 8.8 HEX HEAD	F81001-15	6	
11	WASHER, 6.4 FLAT	F81053-1	6	
12	SENSOR, XS1M08PC410D MAGNETIC SHUTOFF	088268	1	
13	BRACKET, MAGNETIC SHUTOFF SENSOR MOUNT	088366	1	
14	MAGNET, ORANGE SHUTOFF	S10519	1	

## 6.5 Oil Pump/Pan

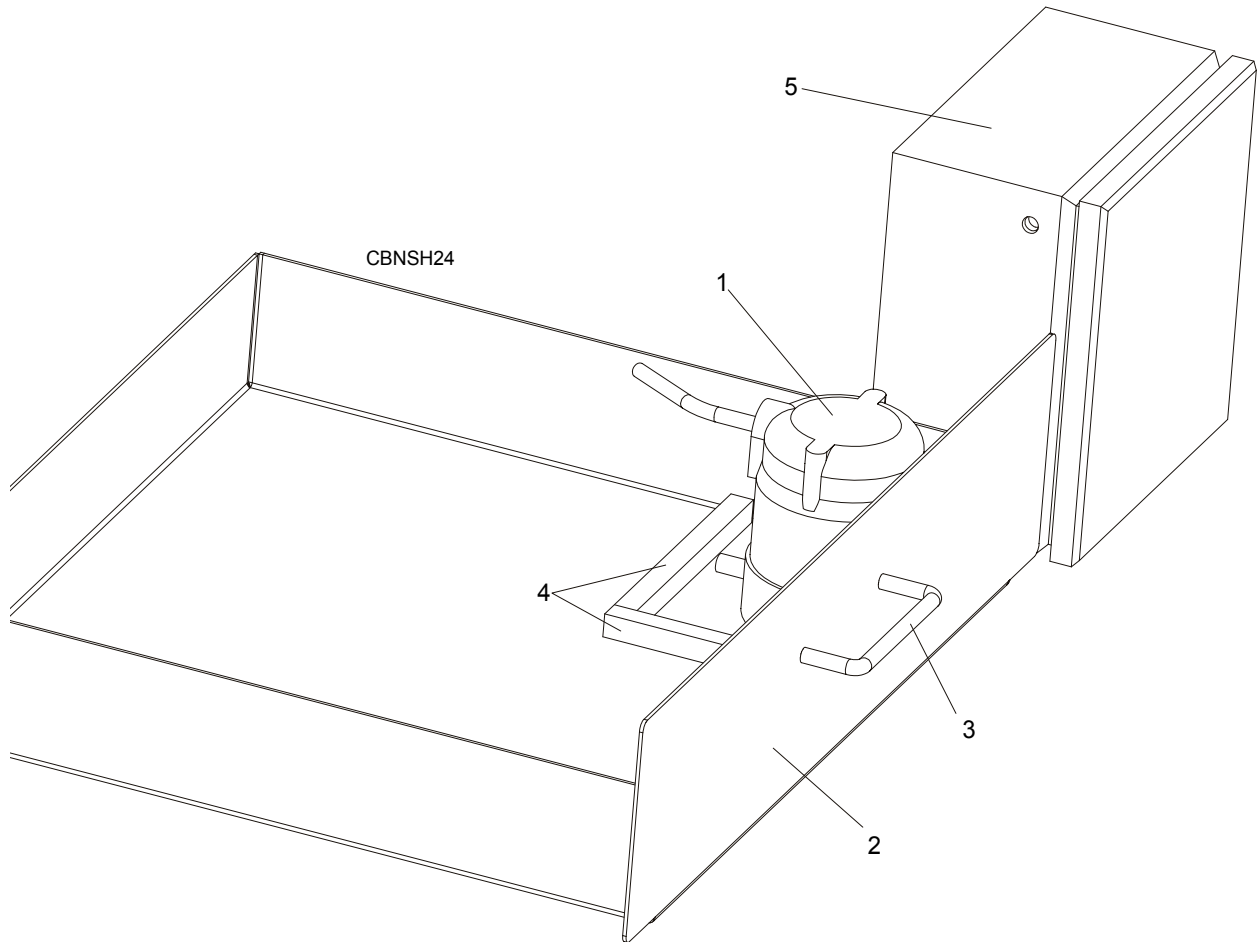

REF	DESCRIPTION (◆ Indicates Parts Available In Assemblies Only)	PART #	QTY.	
1	<b>PUMP, OIL</b>	P09836	1	
2	<b>PAN, OIL</b>	088201	1	
3	Handle w/Bolts	P08065	1	
4	<b>MAGNET, OIL FILTER</b>	P31347	2	
5	<b>BOX, CBN SHARPENER CONTROL</b>	092628	1	

## 6.6 Cam Assembly

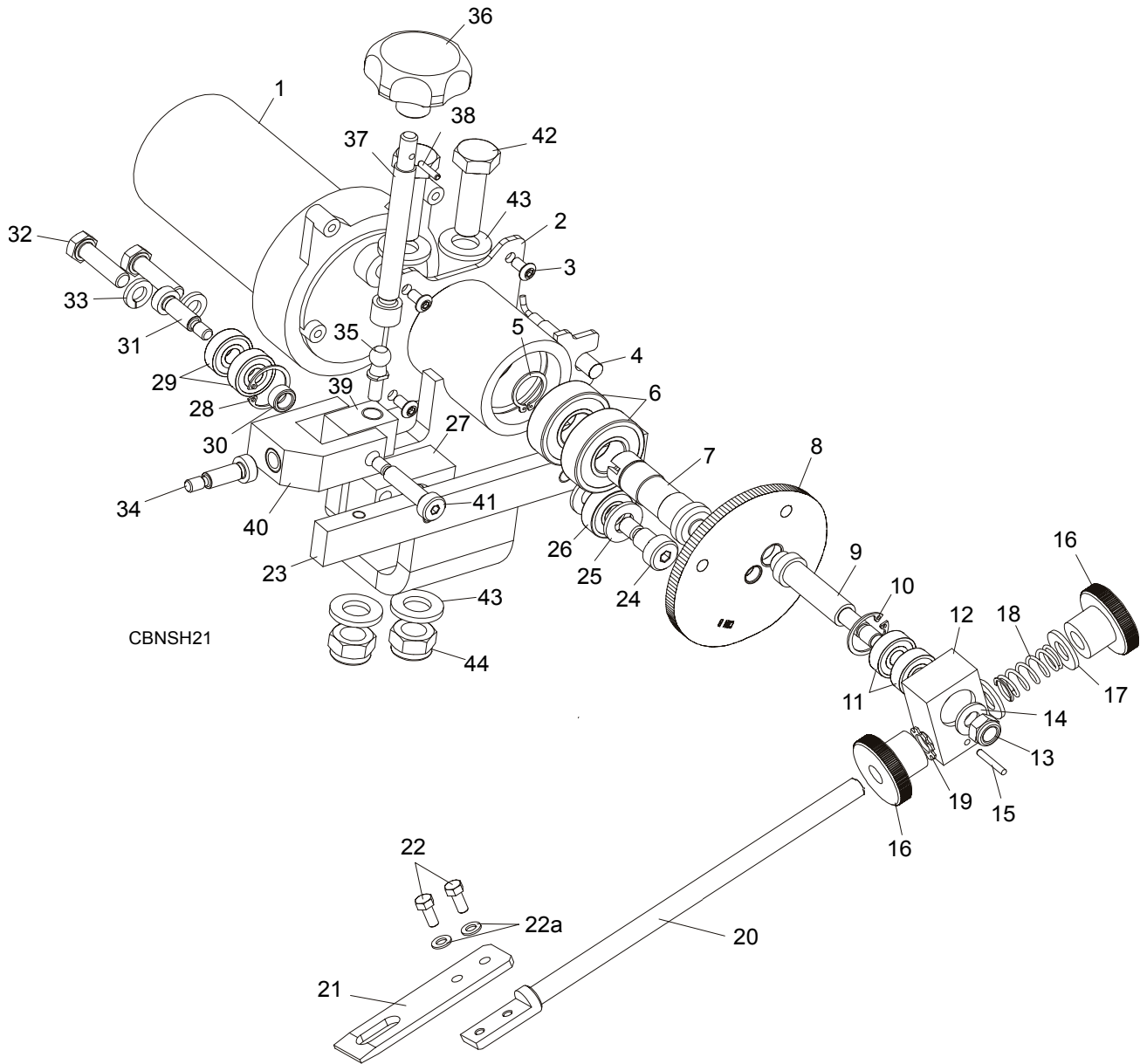

REF	DESCRIPTION (◆ Indicates Parts Available In Assemblies Only)	PART #	QTY.
	<b>INDEXER ASSEMBLY</b>	N/A	1
	Cam Assembly	087369	1
1	Motor, Cam	P09698-1	1
2	Cam Motor Mount	087371	1
3	Screw, Motor Mount	F05004-56	4
4	Sensor, Tooth Counter	087709	1
5	Ring, Z17 Retaining	F81090-21	1
6	Bearing, 6203-2RS Ball	086114	2
7	Shaft, Cam Drive	087366	1

8	Cam, CBN Profile	010741	1	
9	Shaft, Cam Index	087372	1	
10	Ring, W22 Retaining	F81090-7	1	
11	Bearing, 608-2RS Ball	086197	2	
12	Block, Bearing Mounting	087373	1	
13	Nut, M8-8 Hex Nylon Lock	F81032-2	1	
14	Washer, 8.4 Flat	F81054-1	1	
15	Pin, 3 m 6 x 20-A Roll	F81048-2	1	
16	Knob, Index Arm Adjustment	087375	1	
17	Washer, 10.5 Flat	F81055-1	2	
18	Spring	087376	1	
19	Washer, 10.5 External Ring	F81055-3	1	
20	Index Arm, Threaded	087374	1	
21	End, Index Arm	088602-1	1	
22	Bolt, M5x12 -5.8 Hex Head	F81000-5	2	
22a	Washer, 5.3 Flat	F81052-1	2	
	Lever Assembly	087472	1	
23	Block, Lever	087470-1	1	
24	Bolt, M8 x 12-12.9 Socket Head	F81003-62	1	
25	Washer, 10.5 Flat	F81055-1	2	
26	Bearing, 608-2RS Ball	087471	1	
27	Block, Bearing Mounting	087473-1	1	
28	Ring, W22 Retaining	F81090-7	1	
29	Bearing, 608-2RS Ball	086197	2	
30	Spacer	088260	1	
31	Screw, 8/M6 x 20-12.9 Socket Head Shoulder	F81001-25	1	
32	Bolt, M8 x 30-5.8 Hex Head	F81002-2	2	
33	Washer, 8.2 Split Lock	F81054-4	2	
34	Screw, M6 x 20-12.9 Socket Head Shoulder	F81001-25	1	
35	Bolt, 10/M6 Pivot Head	087476	1	
	Depth Knob Assembly	087482	1	
36	Knob, Depth/Back Grind Adjustment	087485	1	
37	Rod, Depth Adjustment	087484	1	
38	Pin, 3 X 14 Roll	F81044-4	1	
39	Block, Small Depth Rod Mounting	087481-1	1	
40	Block, Big Depth Rod Mounting	087483-1	1	
41	Screw, 8/M6 x 30-12.9 Socket Head Shoulder	F81001-18	1	
42	Bolt, M12 x 40 -8.8 Hex Head	F81004-4	2	
43	Washer, 13 Flat	F81056-1	2	
44	Nut, M12-8 Hex	F81034-2	2	

### 6.7 Cover Assembly

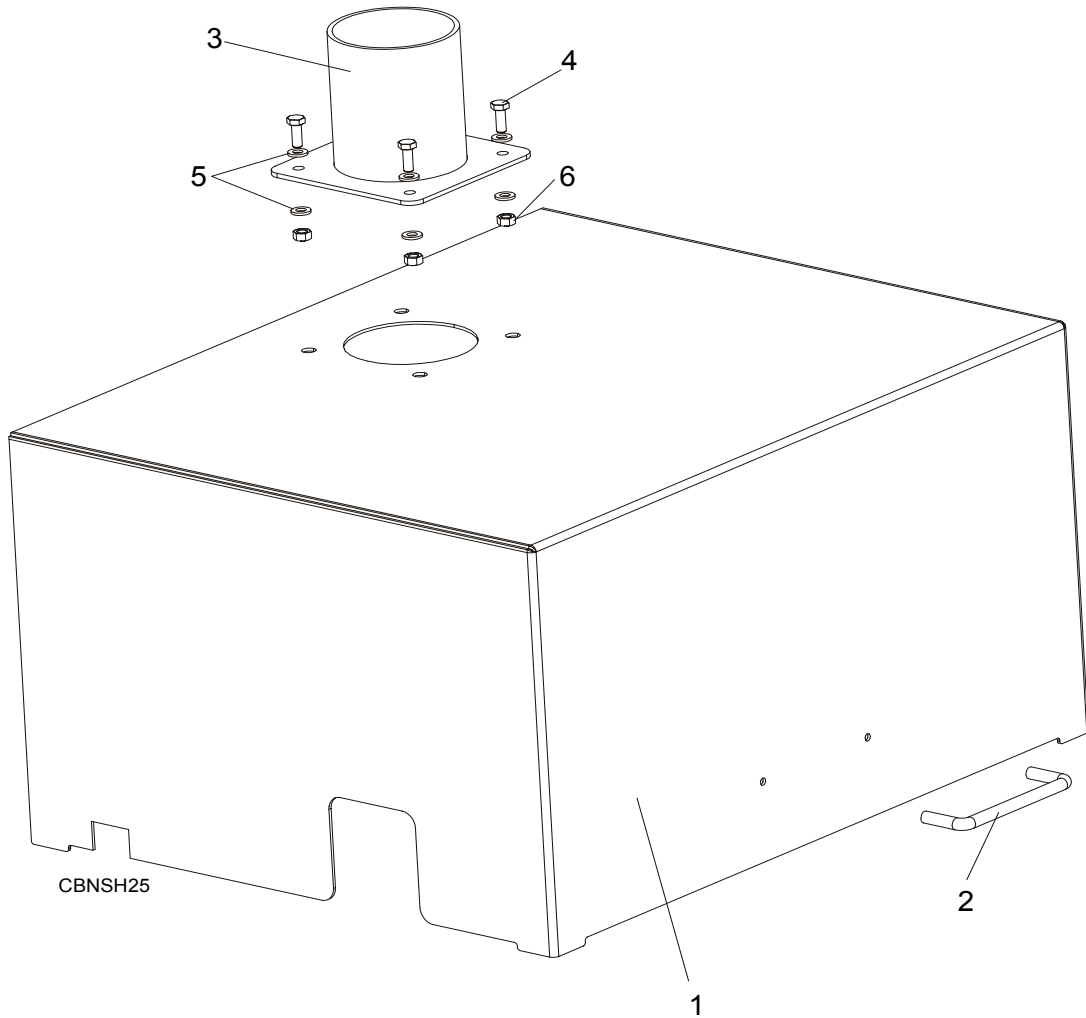

REF	DESCRIPTION (◆ Indicates Parts Available In Assemblies Only)	PART #	QTY.
	<b>SHARPENER COVER, COMPLETE</b>	088302	1
1	Cover Weldment	088254-1	1
2	Handle w/Bolts	P08065	1
3	Pipe, Fume Exhaust Connection	087974-1	1
4	Bolt, M6x16 8.8 Hex Head	F81001-15	4
5	Washer, 6.4 Flat	F81053-1	8
6	Nut, M6 –8 Hex	F81031-1	4

## 6.8 Angled template

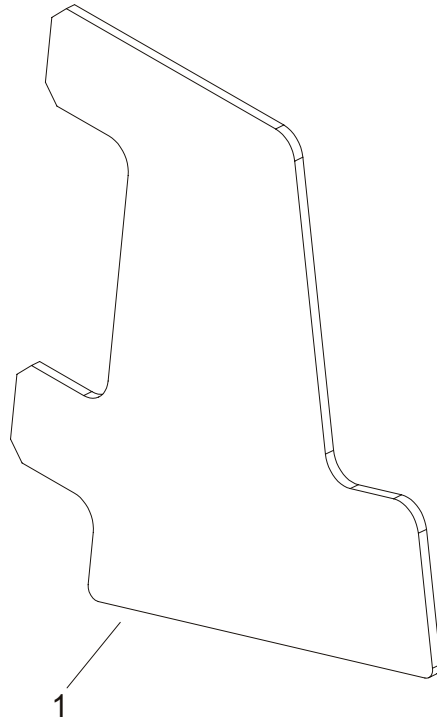

REF.	DESCRIPTION (◆ Indicates Parts Available In Assemblies Only)	PART #	QTY.	
1	ANGLED TEMPLATE FOR 10.30 PROFILE BLADES	088410	1	

**6.9 Alignment tool**

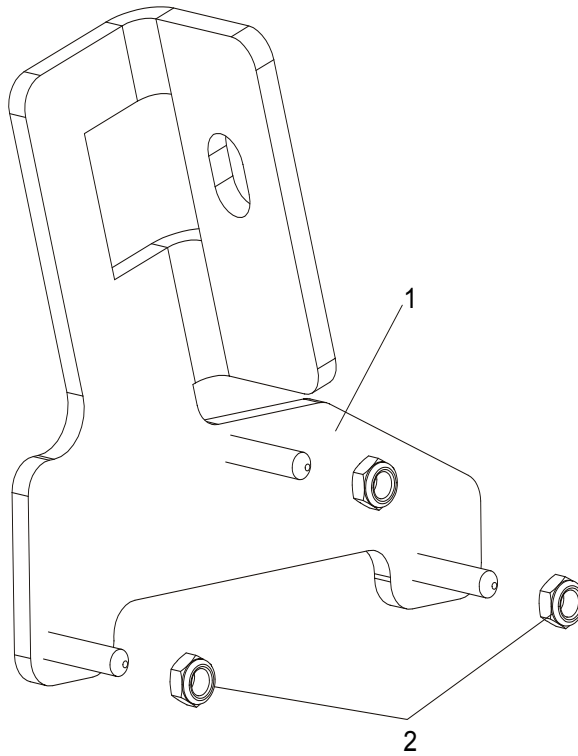

REF.	DESCRIPTION (◆ Indicates Parts Available In Assemblies Only)	PART #	QTY.	
1	ALIGNMENT TOOL	088382	1	
2	Nut M6-8Fe/Zn5	F81031-2	3	



SECTION 7 ELECTRICAL INFORMATION

7.1 Electrical Symbol Diagram

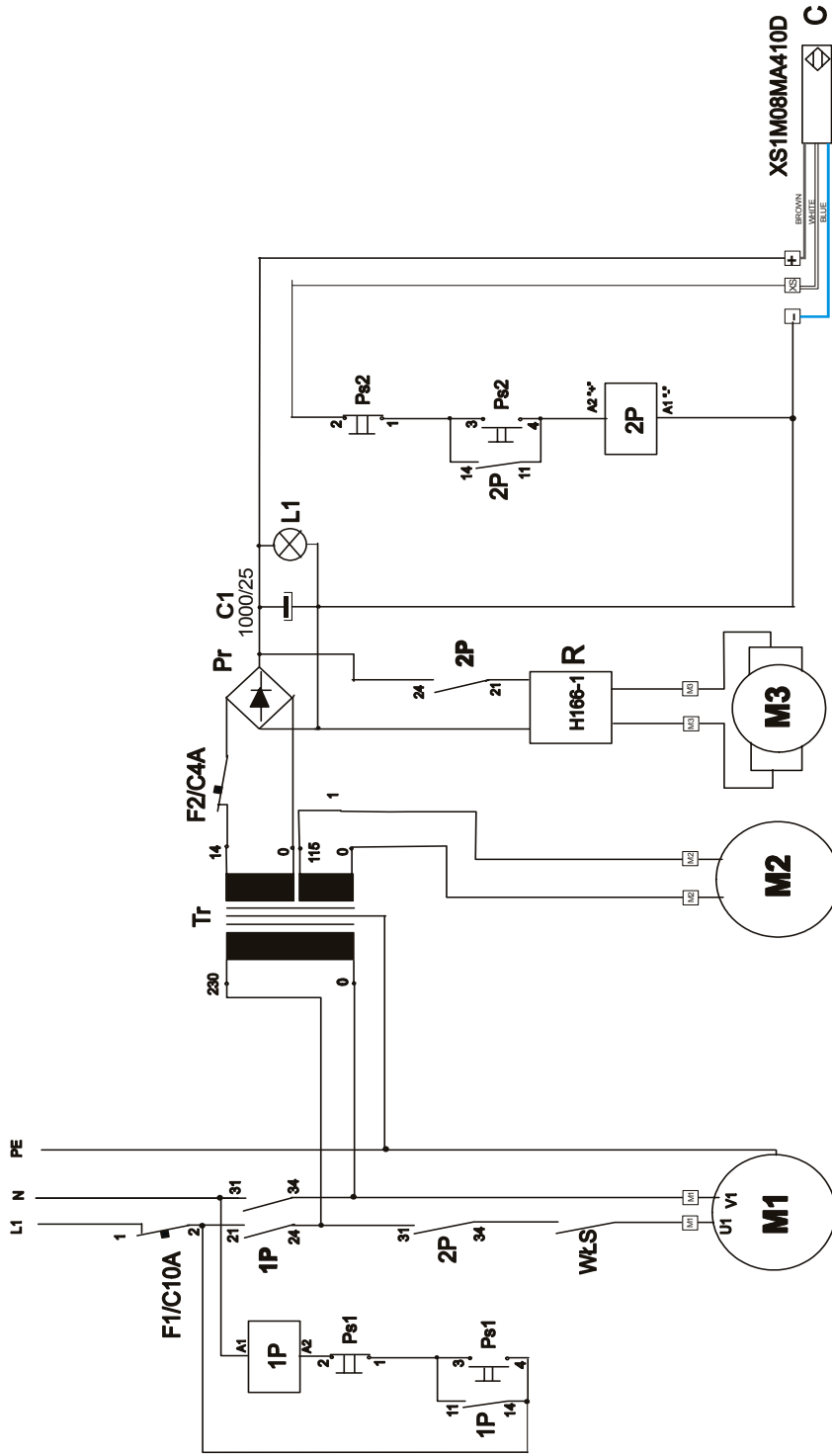
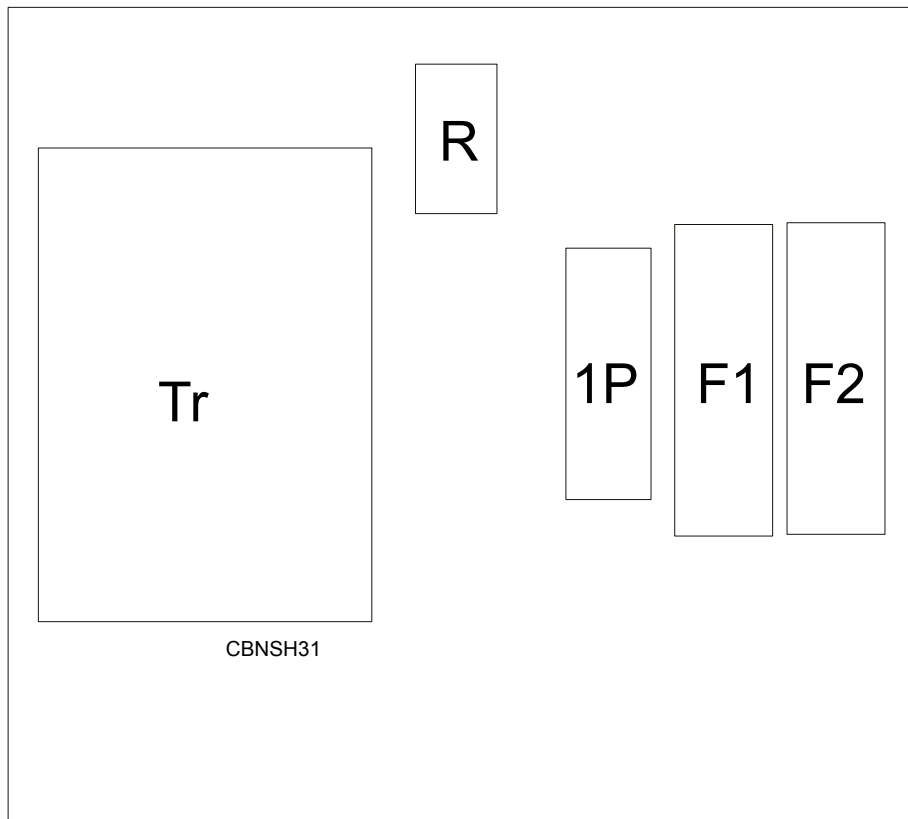

FIG. 7-1

## 7.2 Electrical Component List

Component	Manufacturer	Wood-Mizer Part No.	Description
2P	Finder	091951	Relay, 220V AC type 55.33.9.012.00.10
1P	Finder	090987	Relay, 220V AC type 55.33.8.230.00.10
F1	Schneider	088283	Circuit Breaker, C60N C10 24401
F2	-	E85311	Fuse, 4Amp
Tr	BREVE	090988	Transformer, TMM200/A 230/115/24/14
Pr	-	084318	Bridge-Rectifier, KBPC 3508
WLS	USA	P03027	Grinder Motor Switch
M1	Besel	087769	Grinder Motor, SEKg56 2C2
M2	USA	P09836	Coolant Pump
M3	USA	P09698-1	Motor, Cam (Index)
R	Hybryd	088837	Feed Rate Dial, H166-1
Ps1, Ps2	Schneider	087349	Start-Stop Switch, XB4 BW 84B5
C	Schneider	088268	Magnetic Shutoff Sensor, XS1M08MA410

## 7.3 Component Layout Diagram



**FIG. 7-2**