

LTAGA SHARPENER

Safety, Operation, Maintenance & Parts Manual

LTAGAE	rev. B.00
LTAGAP	rev. B.00



Safety is our #1 concern! Read and understand all safety information and instructions before operating, setting up or maintaining this machine.

August 2001

Form #944

SECTION 1	SAFETY & GENERAL INFORMATION	1-1
1.1	Nomenclature	1-1
1.2	Electrical Safety.....	1-2
1.3	Blade Handling.....	1-2
1.4	Machine Operation	1-2
1.5	Sharpener Components.....	1-4
1.6	Overall Dimensions and Other Technical Data.....	1-4
1.7	Noise Level.....	1-5
1.8	Motor Specifications	1-6
1.9	Coolant Specifications.....	1-6
1.10	Control Panel Components.....	1-7
1.11	Warning Decals Description.....	1-9
SECTION 2	SETUP & OPERATION	2-1
2.1	Machine Start.....	2-1
2.2	Blade Support Installation	2-2
2.3	Blade Height Adjustment	2-2
2.4	Sharpener Alignment.....	2-3
2.5	Grinding Wheel Installation	2-5
2.6	Blade Installation.....	2-6
2.7	Face Grind Adjustment.....	2-7
2.8	Grind Depth Adjustment	2-9
2.9	Oil Flow Adjustment	2-9
2.10	Feed Rate Adjustment	2-9
2.11	Magnetic Shut-off (not in LTAGA-PLCBN EC Version)	2-10
2.12	Blade Rejection	2-10
2.13	Operation Overview	2-11
2.14	Shutoff.....	2-11
SECTION 3	MAINTENANCE	3-1
3.1	Grinding Wheel Replacement	3-1
3.2	Oil Level.....	3-1
SECTION 4	MAINTENANCE & TROUBLESHOOTING	4-1
4.1	Sharpener Maintenance	4-1
4.2	Blade Sharpening Tips	4-2
SECTION 5	ALIGNMENT	5-1
5.1	Sharpener Head Stop Alignment.....	5-1

SECTION 6 REPLACEMENT PARTS 6-1

6.1	How To Use The Parts List	6-1
6.2	Blade Support Assembly	6-2
6.3	Grinder Assembly	6-3
6.4	Sharpener Mounting Plate	6-5
6.5	Blade Clamp Assembly	6-6
6.6	Oil Pump/Pan.....	6-8
6.7	Cam Assembly.....	6-9
6.8	Cover Assembly	6-11
6.9	Alignment tool.....	6-12

SECTION 7 ELECTRICAL INFORMATION 7-1

7.1	Electrical Diagram, LTAGAE-SA 230V 50 Hz.....	7-2
7.2	Electrical Components, LTAGAE-SA 230V 50 Hz	7-3
7.3	Electrical Diagram, LTAGAE-UA 230V 60 Hz	7-4
7.4	Electrical Components, LTAGAE-UA 230V 60 Hz	7-5
7.5	Electrical Diagram, LTAGAE-UM 110V 60 Hz	7-6
7.6	Electrical Components, LTAGAE-UM 110V 60 Hz	7-7
7.7	Electrical Diagram, LTAGAP-SA 230V 50 Hz.....	7-8
7.8	Electrical Components, LTAGAP-SA 230V 50 Hz	7-9
7.9	Electrical Diagram, LTAGAP-UA 230V 60 Hz	7-10
7.10	Electrical Components, LTAGAP-UA 230V 60 Hz	7-11
7.11	Electrical Diagram, LTAGAP-UM 110V 60 Hz.....	7-12
7.12	Electrical Components, LTAGAP-UM 110V 60 Hz	7-13

Manufacturer Data:

Wood-Mizer Industries, Ltd.

Nagórna 114

62-600 Koło

Poland

Tel. +48 63 26 26 000

If You Need To Order Parts...

From Europe call our European Headquarters and Manufacturing Facility in Kolo, Poland at **+48-63-2626000**. Wood-Mizer will accept the following methods of payment:

- Visa, Mastercard, or Select Purchase
- COD
- Prepayment
- Net 15 (with approved credit)

Be aware that shipping and handling charges may apply. Handling charges are based on size and quantity of order. In most cases, items will ship on the day they are ordered. Second Day and Next Day shipping are available at additional cost.

If You Need Service...

From Europe call our European Headquarters and Manufacturing Facility in Kolo, Poland at **+48-63-2626000**. Ask to speak with a Customer Service Representative. Please have your customer number ready when you call. The Service Representative can help you with questions about alignment of your equipment. He also can schedule you for a service call.

Office Hours: All times are Eastern Standard Time.

Country	Monday - Friday	Saturday	Sunday
Poland	7 a.m. to 3 p.m.	Closed	Closed



IMPORTANT! Read the entire Operator's Manual before operating the conveyor. Take notice of all safety warnings throughout this manual and those posted on the equipment. Keep this manual with this equipment at all times, regardless of ownership.

*Wood-Mizer® is a registered trademark of Wood-Mizer Products, Inc.

SECTION 1 SAFETY & GENERAL INFORMATION



This symbol calls your attention to instructions concerning your personal safety. Be sure to observe and follow these instructions. This symbol accompanies a signal word. The word **DANGER** indicates an imminently hazardous situation which, if not avoided, will result in death or serious injury. **WARNING** suggests a potentially hazardous situation which, if not avoided, could result in death or serious injury. **CAUTION** refers to potentially hazardous situations which, if not avoided, may result in minor or moderate injury to persons or equipment. Read all safety instructions before operating this equipment and observe all safety warnings!



Warning stripes are placed on areas where a single decal would be insufficient. To avoid serious injury, keep out of the path of any equipment marked with warning stripes.

Read and observe all safety instructions before operating this equipment! Also read any additional manufacturer's manuals and observe any applicable safety instructions including dangers, warnings, and cautions.

Always be sure that all safety decals are clean and readable. Replace all damaged safety decals to prevent personal injury or damage to the equipment. Contact your local distributor, or call your Customer Service Representative to order more decals.

Always properly dispose of all by-products, including debris, coolant and oil.

Safety instructions are listed in this section by the following operations:

- Electrical Safety
- Blade Handling
- Machine Operation

1.1 Nomenclature

Machine Name	Version		Electric Standards Code		Voltage Code	
LTAGA	P	Professional (standard)	S	50Hz EU standards	A	230V 1ph
	E	Economic class sharpener	U	60Hz UL standards	M	110V 1ph

TABLE 1-1

Possible combinations:

Model	Description
LTAGAP-SA	Sharpener/ standard/ 1x230V 50Hz
LTAGAP-UA	Sharpener/standard/ 1X230V 60Hz UL
LTAGAP-UM	Sharpener /standard/1x110V 60Hz UL
LTAGAE-SA	Sharpener/economic/1x230V 50Hz
LTAGAE-UA	Sharpener/economic/1x230V 60Hz UL
LTAGAE-UM	Sharpener/economic 1x110V 60Hz UL

TABLE 1-2

1.2 Electrical Safety



DANGER! Make sure all electrical installation, service and/or maintenance work is performed by a qualified electrician and is in accordance with applicable electrical codes.

DANGER! HAZARDOUS VOLTAGE can cause shock, burns, or death. SHUT OFF & LOCK OUT POWER before performing service in any area of this machine. DO NOT restore power until all access panels are replaced and secured.



WARNING! Always turn off and disconnect power at control console AND at main supply circuit breaker before performing any service to the machine.

1.3 Blade Handling



WARNING! Always wear gloves and eye protection when handling bandsaw blades. Keep all persons away from area when coiling or carrying a blade (4 meters at least).

1.4 Machine Operation



CAUTION! Read thoroughly the operator's manual before operating the sharpener.



DANGER! Make sure all guards and covers are in place and secured before operating the sharpener. Failure to do so may result in serious injury.

DANGER! Keep all persons away from moving parts when operating this machine (2 meters at least). Failing to do so will result in serious injury.

DANGER! Always keep hands away from moving bandsaw blade. Failure to do so will result in serious injury.



WARNING! Always wear eye, ear, respiration, and foot protection when operating this machine. Failure to do so may result in serious injury.

WARNING! Secure all loose clothing and jewelry before operating this machine. Failure to do so may result in serious injury or death.

WARNING! The sharpener should not be operated by persons allergic to ACP-1 oil or its vapors.



CAUTION! The sharpener's work-stand should be equipped with a 4 kg or bigger dry powder extinguisher.

CAUTION! The machine has to be used only for sharpening blades. Otherwise the warranty will expire.

CAUTION! The machine has to be used only with oil vapour extractor.

1.5 Sharpener Components

The LTAGA-PLCBN sharpener is designed for sharpening only Wood-Mizer blades with 9.29, 10.30, 13.29 and 4.32 profiles.

See **Figure 1-1**. The major components of the sharpener are shown below.

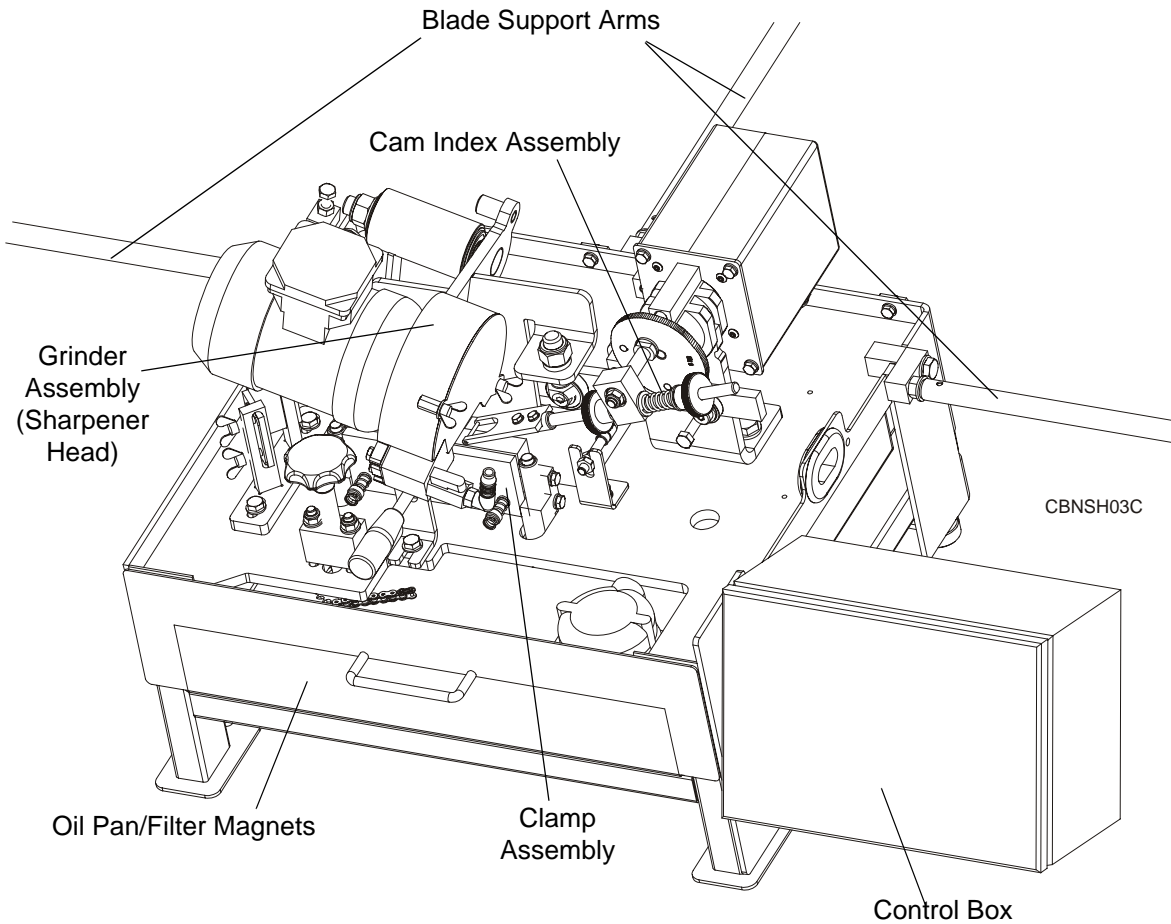

FIG. 1-1

1.6 Overall Dimensions and Other Technical Data

See **Table 1-3**. The overall dimensions and the weight of the PLCBN sharpener (without the blade support arms) are listed below.

	Length	Width	Height	Weight
LTAGA-PLCBN Sharpener	627mm	845mm	590mm	83kg
Sharpener packaged in carton	680mm	960mm	620mm	90kg

TABLE 1-3

See Figure 1-2. The figure below shows the overall dimensions of the PLCBN sharpener with the blade support arms installed.

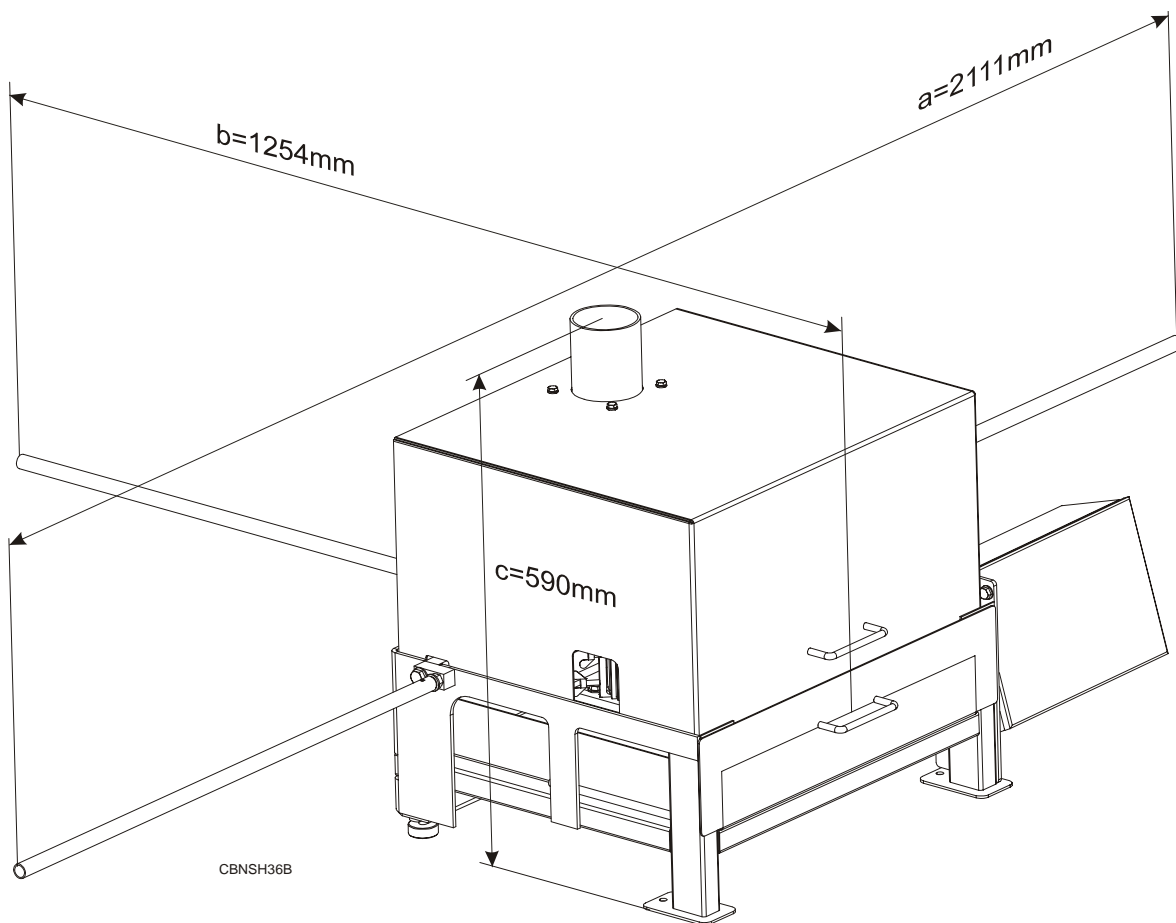

FIG. 1-2

1.7 Noise Level

See Table 1-4. The noise level produced by the LTAGA-PLCBN sharpener is given below ¹.

	Noise Level
LTAGA-PLCBN	74,5 dB (A)

TABLE 1-4

1. The measured values refer to emission levels, not necessarily to noise levels in the workplace. Although there is a relation between emission levels and exposure levels, it is not possible to determine with certainty if preventives are needed or are not needed. The factors affecting a current level of noise exposure during work are inter alia room characteristics and characteristics of other noise sources, e.g. number of machines and machining operations nearby. Also, the permissible exposure level value may vary depending on country. This information enables the machine's user to better identify hazards and a risk .

1.8 Motor Specifications

See Table 1-5. The grinder motor specifications are listed below.

Motor	Manufacturer	Model	Power	Other Data
Electric	Besel, Poland	SEKg 56 2C2	0.18kW	1.5 A, 2800 r.p.m.

TABLE 1-5

1.9 Coolant Specifications

See Table 1-6. The table below lists the coolant specifications.

Oil Type	Manufacturer	Freezing Point	Flash Point	Autoignition Point
ACP-1E ¹	Orlen	-20° C	Above 140° C	250° C

TABLE 1-6

¹ Waste oil must be disposed of in compliance with applicable state and local regulations.

1.10 Control Panel Components

See Figure 1-3. The control panel components and their descriptions are shown below.

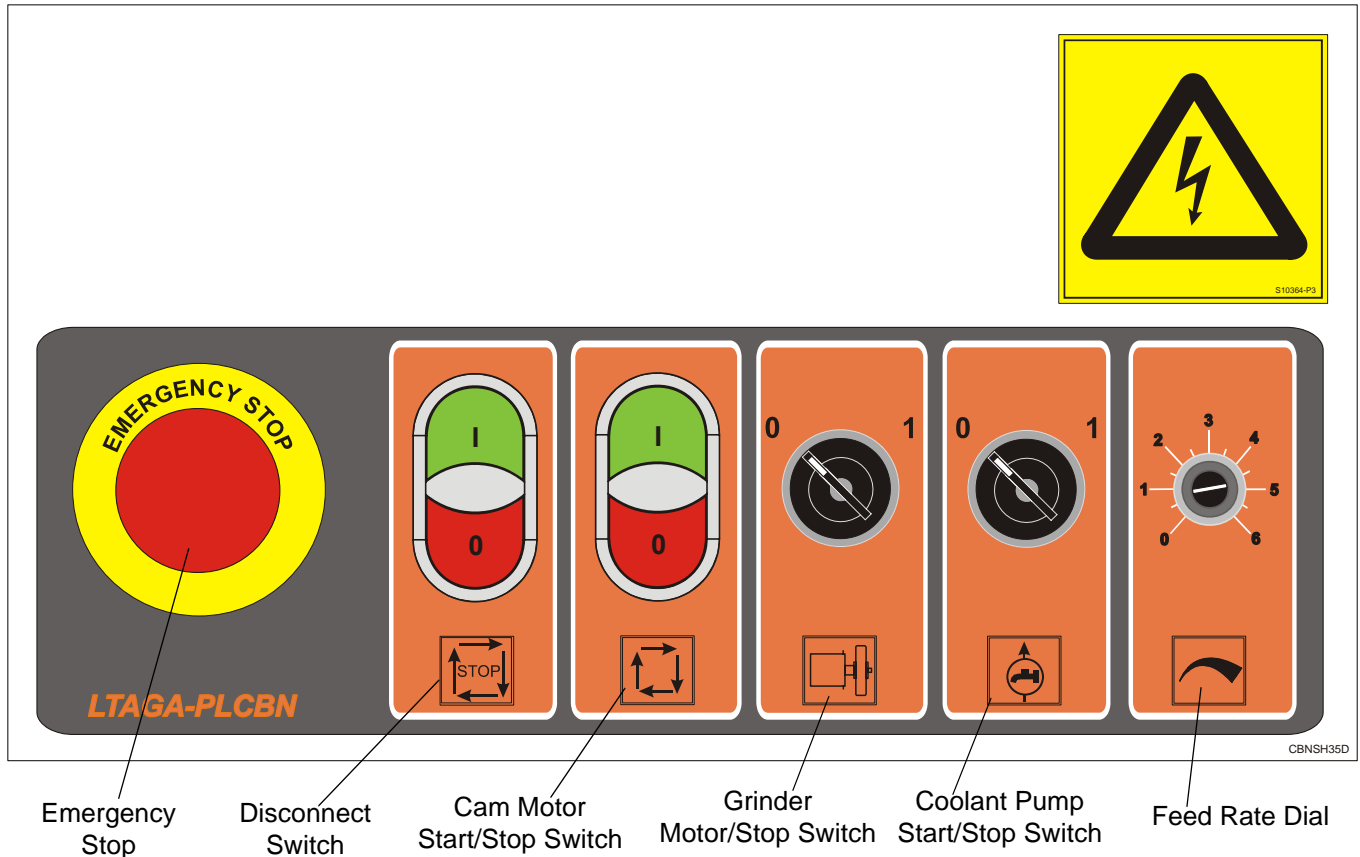

FIG. 1-3

- **Disconnect button**
Turns on/off the sharpener power and the oil pump.

Press the START Button to turn the sharpener power on. Press the STOP Button to turn the sharpener power off.

To reconnect power to equipment, turn switch to the "1", or horizontal, position.

- **Feed Rate Dial**
Controls cam speed.

Rotate dial as necessary to increase or decrease cam speed.

- **Grinder Motor Start/Stop Switch**
Starts/Stops grinder motor.
- **Cam Motor Start/Stop Button**

Press the Cam Motor Start Switch to start the cam motor. **NOTE:** Place the Feed Rate Dial in the "0" position before starting the cam motor.

Press the Cam Motor Stop Switch to turn the cam motor off and unclamp the blade.

- **Coolant Pump Start/Stop Switch**

Starts/Stops coolant pump.

- **Emergency Stop**

Stops the sharpener operation.

In case of any dangerous situation or any incorrectness in the sharpener operation, press the emergency stop button. The button will be locked.

To release the emergency stop button, turn it clockwise.

See Figure 1-4. The control panel components of the **LTAGA-EC** version and their descriptions are shown below.

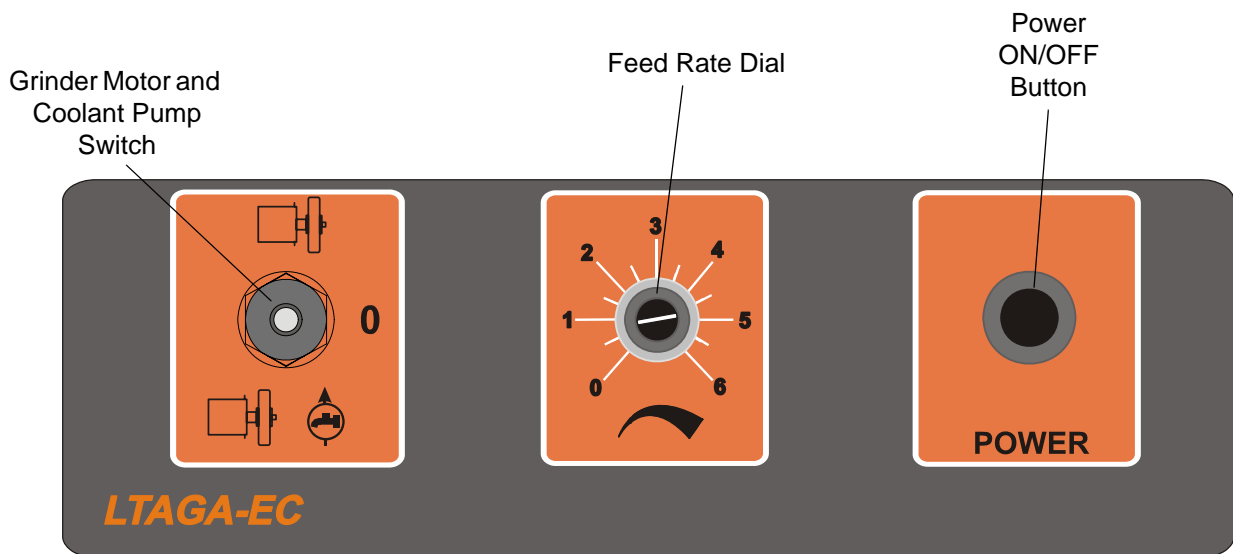

FIG. 1-4

- **Grinder Motor and Coolant Pump Start/Stop Switch**

Starts/Stops grinder motor and coolant pump. Move the switch to upper position to start the grinder motor only (it can be used to adjust the sharpener). Move the switch to lower position to start the grinder motor and the coolant pump.

- **Feed Rate Dial Controls cam speed.**

Rotate dial as necessary to increase or decrease cam speed. Turn the dial to "0" position to stop the cam.

- **Power ON/OFF Button**

Turns on the power to all motors of the sharpener. **NOTE:** Place the Feed Rate Dial in the "0" position before turning on the power.

1.11 Warning Decals Description

See Table 1-7. The pictographic decals that warn and inform the user are shown and described below.

TABLE 1-7







Decal View	Decal No.	Description
	S10364-P3	"Hazardous voltage".
	086362	General warning symbol
	099220	CAUTION! Close all guards and covers before starting the machine.

TABLE 1-7

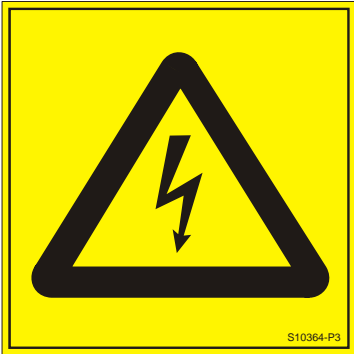
 <p>095961</p>	<p>095961</p>	<p>"Use ACP-1 oil."</p>
	<p>S12004G-1</p>	<p>CAUTION! Always wear safety goggles when operating the sharpener!</p>
 <p>2800 RPM</p> <p>S20097C</p>	<p>S20097C</p>	<p>2800 RPM - Motor rotation direction</p>
	<p>P85070</p>	<p>CE safety certification</p>

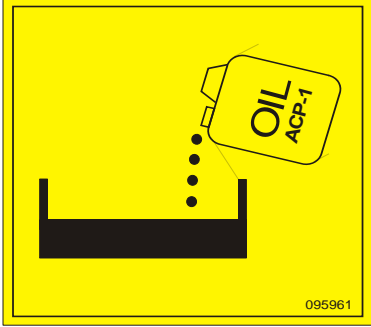
SECTION 2 SETUP & OPERATION

2.1 Machine Start



IMPORTANT! Before starting to use the machine you have to meet the following conditions:

- Fasten the sharpener to a table top using the mounting holes located in the foot plates.
- The sharpener can be operated with a oil vapors exhaust system only.
- The machine can be operated under roof only.
- The sharpener can be operated only in temperature range from 5° C to 40° C, at the humidity of up to 80%.
- The oil for cooling the grinding wheel must meet the specifications listed in Table 1-4 on page 9. Water or other liquids must not be used.
- The position of the sharpener's operator is shown below.

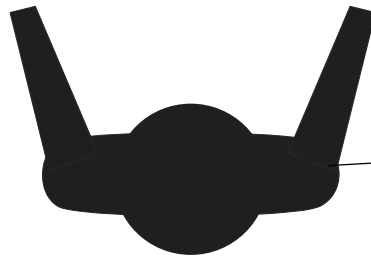
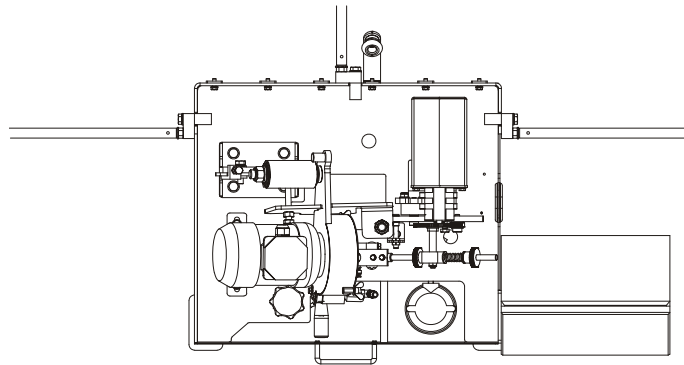

Operator's Position

- Have a qualified electrician make the power supply. The power supply must meet the specifications given below.

2-Phase Volts	Fuse [A]	Suggested Wire Size
230 VAC	10 A	1.5 mm at least ²

TABLE 2-0

2.2 Blade Support Installation

The sharpener includes three blade support arms with guide assemblies.

To install the support arms, lubricate the threaded ends of the arms with grease. Insert one arm into the threaded holes on each side of the sharpener.

1. Each guide assembly consists of a blade support with post, a blade support without post, two bolts, a self-locking nut, and a wing nut.

See Figure 2-1. To install the guides, join one guide assembly around the end of each blade support arm. Face the post outward as shown. Bolt from the hexed side of the guide assembly (these hex-shaped holes will keep the bolts from turning once in place). Secure the top bolt with a self-locking nut. Secure the bottom bolt with a wing nut.

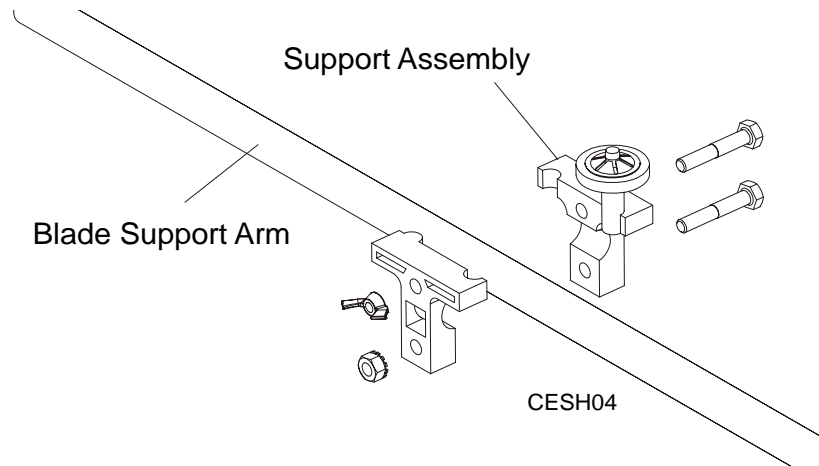

2. Tilt the guides on the left blade support arm slightly backward, toward the rear of the sharpener. Tilt the guides on the right support arm slightly forward, toward the front of the sharpener.

2.3 Blade Height Adjustment

The LTAGA-PLCBN sharpener is equipped with a blade height adjustment assembly that allows smooth height adjustment of 1", 1 1/4", 1 1/2", 1 3/4" and 2" wide blades.

To install the blade, release the blade clamp by pushing the clamp handle down.

See Figure 2-2. Position the blade on the cylindrical rollers of the blade height adjustment screws as

shown below. Use the blade height adjustment knob to adjust the blade height.

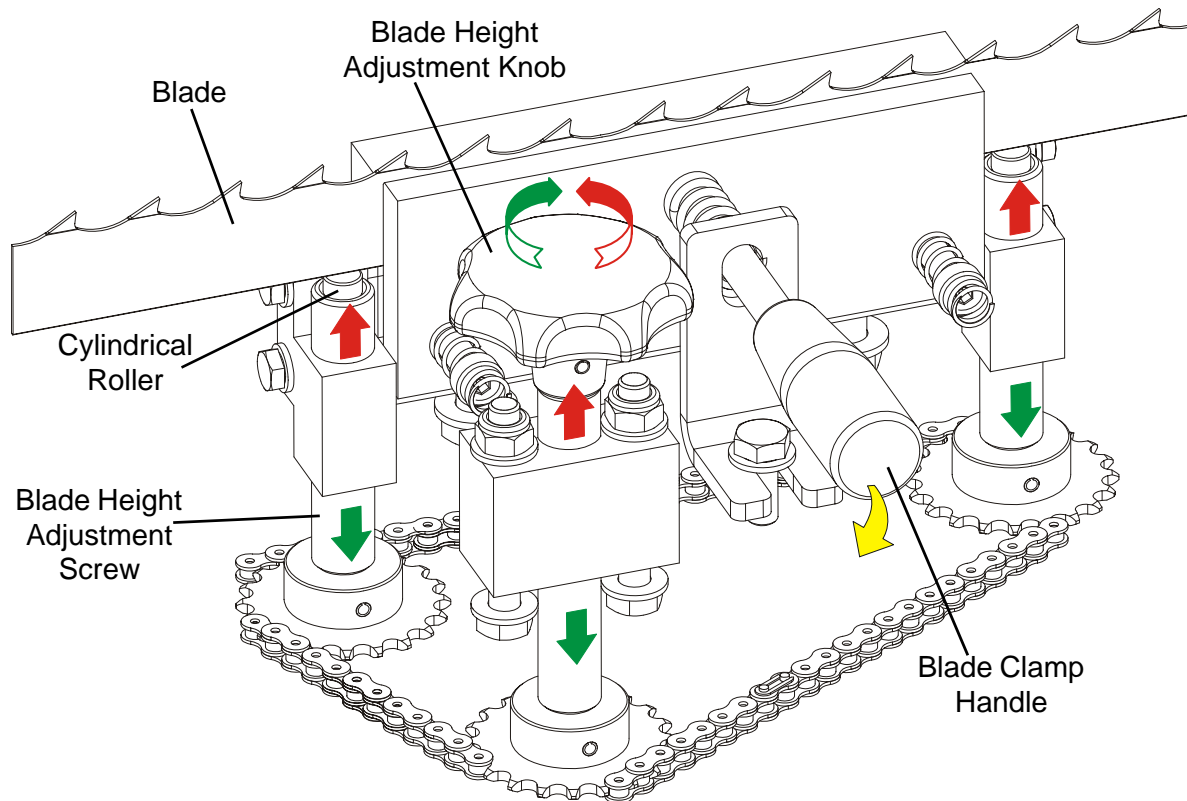

FIG. 2-2

NOTE: After adjusting the blade height, adjust the blade support arms in the vertical plane as necessary so the blade will remain level around its complete length.

2.4 Sharpener Alignment

Use the provided LTAGA-PLCBN sharpener alignment tool as necessary to achieve accurate alignment between the blade clamp and the grinding wheel.

IMPORTANT! Do not adjust the alignment tool bolts. They have been pre-calibrated at the factory to ensure accurate alignment results.

1. **IMPORTANT!** Make sure the grinder motor is OFF. Cycle the cam until the grinding wheel is at the tip of the tooth (about to begin face grind).
2. Remove the grinding wheel cover and sharpener arbor nut. Dismount the oiler. Remove the grinding wheel.
3. Remove the blade rest bolts and moving clamp plate.
4. Install the alignment tool to the grinder motor shaft as shown below.

See **Figure 2-3**. Position the tool so all three gauge points are in line with the front clamp plate. Secure the tool in position with the sharpener arbor nut.

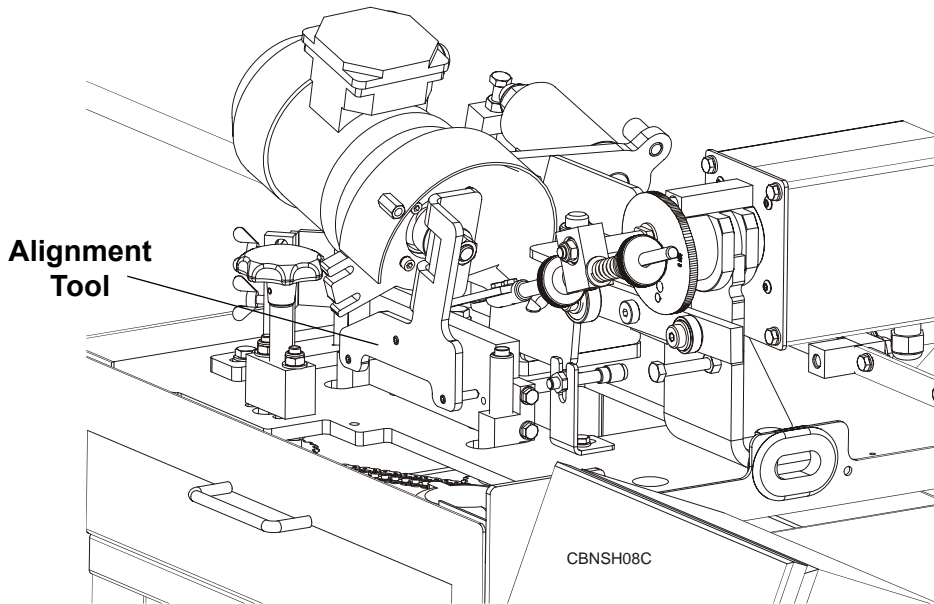

FIG. 2-3

5. Loosen the clamp adjustment bolts.
6. Position the clamp assembly so the front clamp plate touches all three tool gauge points. Secure in position by tightening the clamp adjustment bolts.

See **Figure 2-4**.

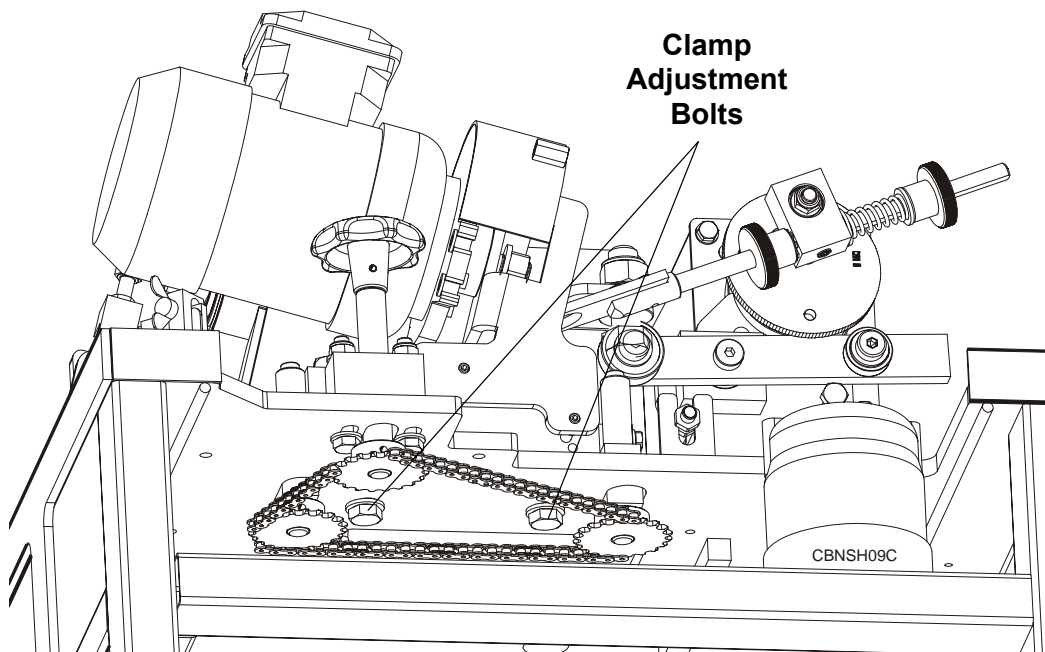

FIG. 2-4

7. Remove the arbor nut and alignment tool.
8. Reinstall the moving clamp plate.
9. Reinstall the grinding wheel and secure in place with the arbor nut.
10. Mount the oiler. Reinstall the grinding wheel cover.

2.5 Grinding Wheel Installation

Use a Wood-Mizer approved grinding wheel. To install:

1. Push the START button on the control box and turn the FEED RATE dial up to rotate the cam.
2. Rotate the cam until the sharpener head is at its highest setting. Turn the FEED RATE all the way down and push the STOP button.
3. Remove the grinding wheel cover.
4. Remove the oiler.
5. Remove the arbor nut.
6. Slide a grinding wheel onto the motor shaft.
7. Reinstall the arbor nut and hand tighten. Reinstall the grinding wheel cover and oiler.



DANGER! Make sure all guards and covers are in place and secured before operating the sharpener. Failure to do so may result in serious injury. Also check that the grinding wheel does not contact the oiler. If it contacts, adjust the oiler out of the way. (The gap between the grinding wheel and the oiler should be .5 – 1 mm.)

8. If the installed grinding wheel is running out axially, unscrew the arbor nut, turn the grinding wheel about 15 degrees and replace the arbor nut. Then check the grinding wheel's rotation. If the axial runout is still present, perform the above-mentioned steps again. Repeat them as necessary until the problem is corrected.
9. After installing and adjusting the grinding wheel, hold the sharpener head up with your hand and turn the back/depth grind knob until you can lower the head and the grinding wheel will not contact the blade. Carefully lower the sharpener head.

2.6 Blade Installation

See **Figure 2-5**. Before installing a blade, push the cam motor START switch and turn the FEED RATE dial until the cam pivot bolt is at the 2 o'clock position.

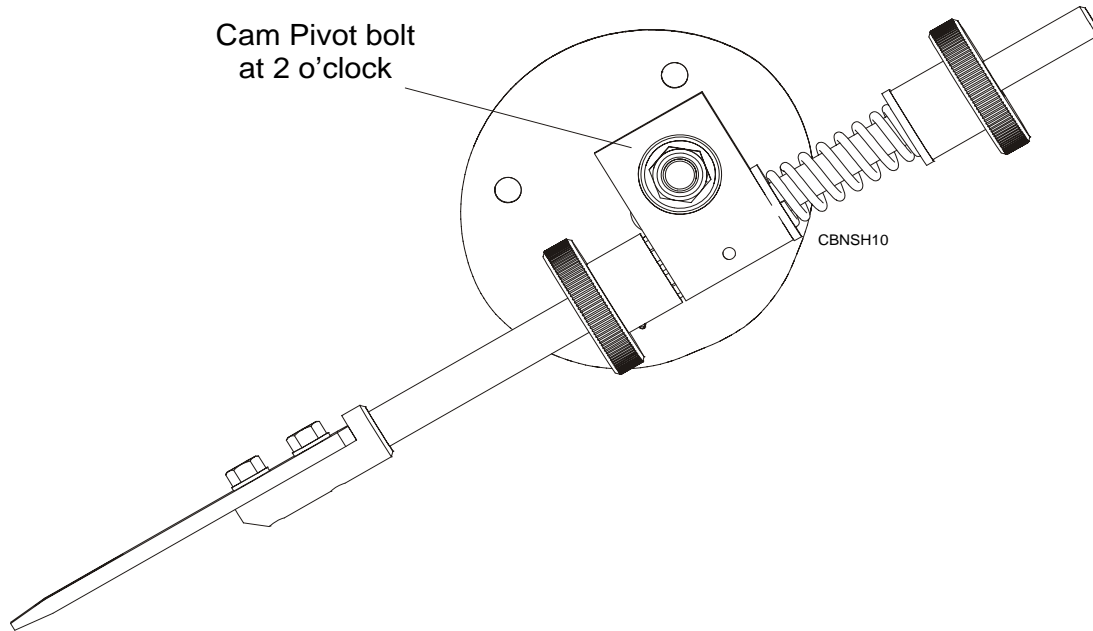

FIG. 2-5

Uncoil a blade and position above the three support assemblies around the sharpener. Check to be sure the teeth on the portion of blade that will be under the grinding wheel point to the right as you face the sharpener. If not, remove the blade and invert it.

See **Figure 2-6**. Position the blade inside the left and rear blade support posts.

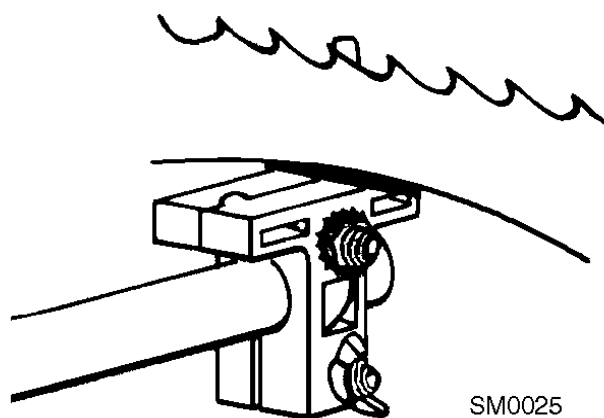

FIG. 2-6

See **Figure 2-7**. Position the blade outside the right blade guide wheel.

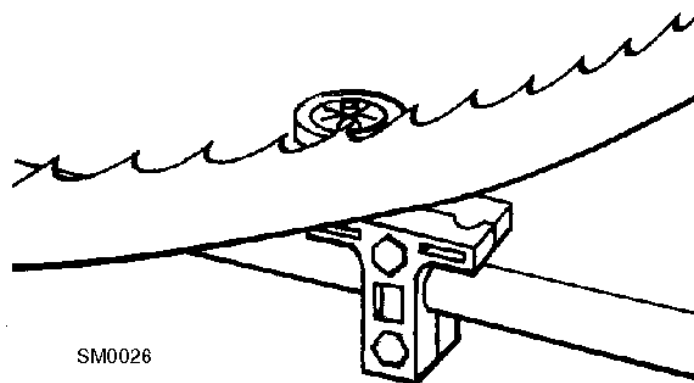

FIG. 2-7

Holding the blade with your left hand, lift the sharpener head. Then raise and hold the indexing arm up, loosen the blade clamping fixture and press the blade between the clamping plates. Lower the indexing arm and the sharpener head.

Make final adjustments to the blade support arms and guide assemblies. Make sure the blade band rests evenly on both blade rest bolts. The blade should not touch the bottom of either side guide assembly. All three guide assemblies should lean slightly in the direction the blade travels through them.

Bend the blade wiper on the left side of the sharpener so that it touches the blade. The wiper will wipe coolant from the blade into the oil pan so it does not drip on the floor.

2.7 Face Grind Adjustment

As you operate the sharpener, the cam will rotate causing the index arm to contact a tooth and push it to a position under the grinding wheel. The index arm can be adjusted to leave the tooth closer to or further from the grinding wheel so the tooth face is ground lighter or heavier.

1. Before adjusting the face grind, make sure the cam and grinder motors are off, the feed rate dial is set at "0" and the Sharpener head is raised.
2. Install the blade.
3. Turn on the cam motor and slowly increase the FEED RATE until the next tooth is underneath the grinding wheel.
4. Lower the Sharpener head and check to make sure the grinding wheel lightly contacts the entire face of the tooth all the way up to the tip.

See Figure 2-8. If the face grind is too light, turn the face grind adjustment knob out away from the other knob. If the face grind is too heavy, turn the adjustment knob in toward the other knob.

5. Recheck the face grind on the next tooth and adjust as needed.

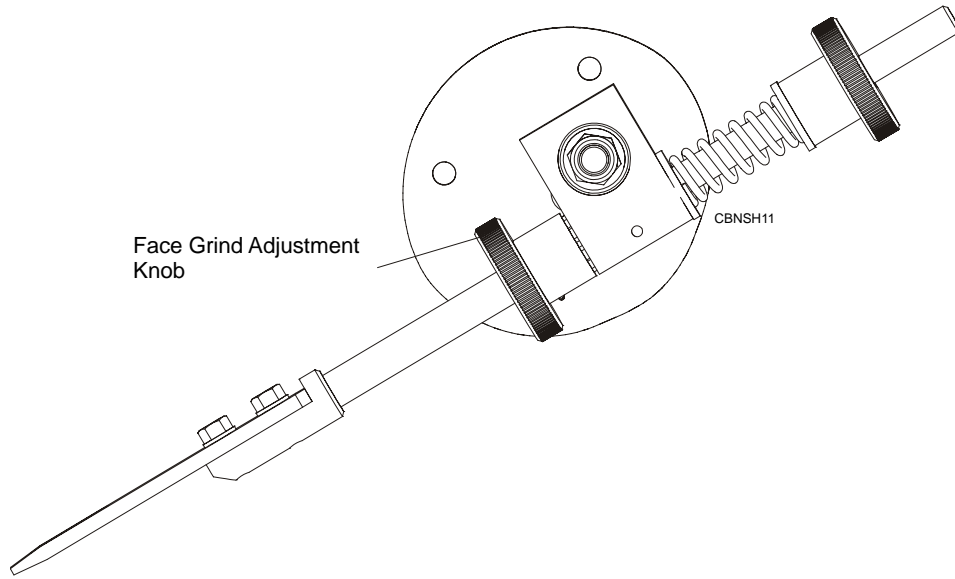

FIG. 2-8

See Figure 2-9. Proper position of the grinding wheel to blade during sharpening is shown on the picture below.

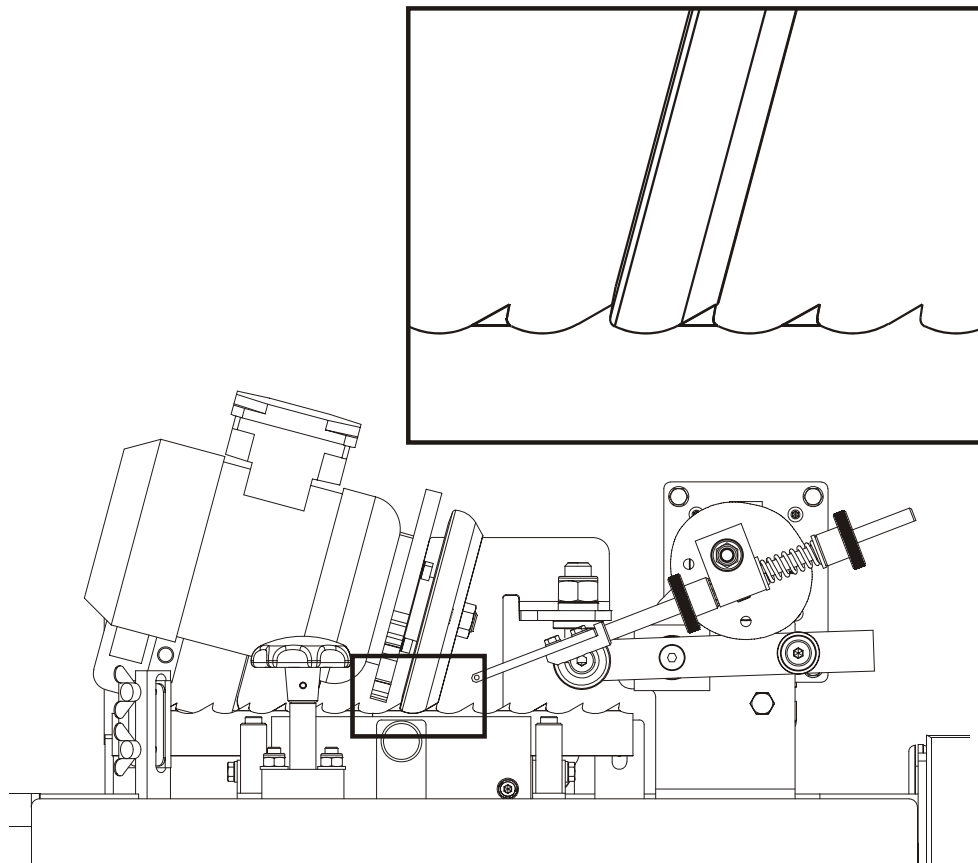

FIG. 2-9

2.8 Grind Depth Adjustment

Tooth height is determined by how much material is removed from the gullet of the blade. The Wood-Mizer sharpener is equipped with a grind depth adjustment bolt that controls how far the grinding head comes down and therefore controls the gullet grind. (See *Figure 2-10.*)

CAUTION! The grind depth adjustment bolt is factory-set and should not need to be readjusted. The gullet grind should be adjusted by setting the blade height with the blade height adjustment knob. (See [Section 2.3.](#))

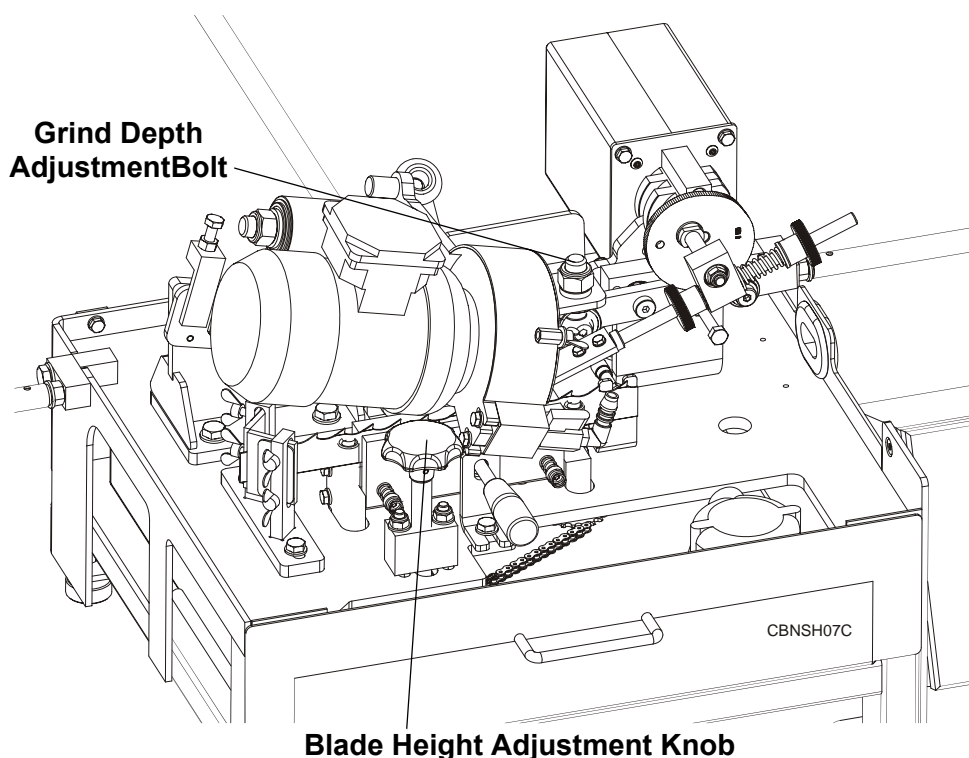

FIG. 2-9

NOTE: Depth grind may be affected as the grinding wheel passes over blade welds.

2.9 Oil Flow Adjustment

To activate blade oiling, open the oil flow control valve located on the oiler.

2.10 Feed Rate Adjustment

The Feed Rate Dial controls cam speed. During the sharpening cycle, adjust cam speed to have as fast of a feed rate as possible without "burning" the blade.

NOTE: All machines should be adjusted by maintenance to a maximum speed of 60 revolutions per minute. [See Section 4.2.](#)

2.11 Magnetic Shut-off (not in LTAGA-PLCBN EC Version)

See **Figure 2-10**. The shut-off sensor is located to the right of the blade clamp assembly. When passed over by a magnet, it automatically shuts down the grinder and cam motors.

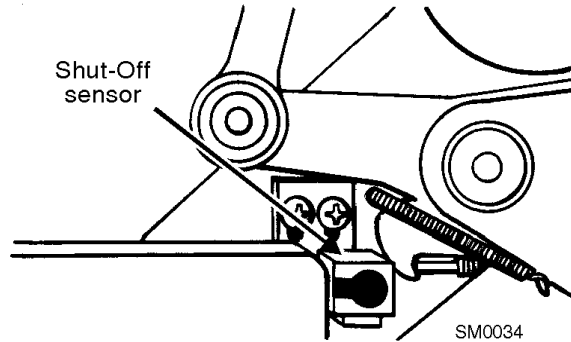

FIG. 2-10

To install, take an orange-painted magnet from the bag assembly. Place the black side of the magnet against the bottom edge of the blade on the inside of the tenth face-ground tooth. After the sensor bracket has shut off the cam and grinder motors, flip the grinder switch into the off position. Remove the magnet.

2.12 Blade Rejection

Sometimes blades cannot be resharpened. Reasons to reject blades for resharpening include:

- the blade is coil set (the blade is over-stressed and will fold on itself),
- the blade is missing 2 or 3 teeth or more in a row,
- the blade band has been twisted,
- the blade band is too low for the grinder (the blade has been sharpened too many times/too much material has already been ground from the blade),
- the blade has no set on one of its sides,
- severe rust is present,
- or the blade has tooth spacing uncommon to Wood-Mizer blades (i.e., a competitor's blade).

2.13 Operation Overview

Use the following steps to guide you through sharpener operation.

1. Adjust the blade clamp for the blade you will be sharpening.
2. Install a grinding wheel if necessary, then install the blade.
3. Adjust face grind and depth grind.
4. Activate the oil flow.
5. Increase the feed rate to a moderate speed. How fast you can grind will be determined by how much material you are removing from the blade. If a heavy grind is required, it is best to go around the blade lightly twice rather than try to grind heavily once.
6. After about ten teeth have been ground, mount the orange-painted magnet right behind the blade wiper. (See Section 2.11.) If you use the LTAGA-PLCBN EC version, mark the start of sharpening with a sticker or marker.
7. Check the depth grind two to three times during the blade sharpening. Adjust as necessary.

IMPORTANT! After any adjustment, always restart the blade and sharpen in its entirety to ensure symmetry.

2.14 Shutoff

The sharpener will automatically shutoff when blade has been entirely sharpened (not in LTAGA-PLCBN EC Version)

Inspect the blade. Repeat sharpening process if necessary. Blades with a bad profile or those which are badly in need of sharpening may have to be ground more than once.

SECTION 3 MAINTENANCE

3.1 Grinding Wheel Replacement

Check the grinding wheel often and change as necessary. Wheels approved for use with the sharpener are available from Wood-Mizer.

The grinding wheel should be in good condition. Replace if worn, the edges look shiny, and/or the wheel is "burning" the blades. **NOTE:** The grinding wheels have a CBN (Cubic Boron Nitride) coating.

1. To replace, shut down and lock out all power to the machine.
2. Remove the grinding wheel cover.
3. Remove the grinding wheel nut, washer plate and grinding wheel.
4. Install the new grinding wheel. Reinstall the washer plate and nut.
5. Reinstall the grinding wheel cover.

3.2 Oil Level

Periodically check the oil level and refill with oil as necessary. The oil level should be kept between 4.5 and 5 litres. Use only Wood-Mizer approved grinding oil.

Filter the oil to remove metal shavings before reusing.

SECTION 4 MAINTENANCE & TROUBLESHOOTING

4.1 Sharpener Maintenance

Daily:

- Wipe the sharpener dry, remove the blade, lower the head, close the cover and unplug the machine after each day's use.
- Keep clean of dirt, rust, and metal filings.
- Remove the clamp regularly and clean out any buildup that might cause it to not clamp the blade firmly. To do so, unscrew the blade rest bolts and remove the moving clamp plate.

Weekly:

- Clean the grinding wheel.
- Clean sediment from the oil pan and filter magnets as needed.
- Keep the oil at such a level that the pump strainer is completely covered with the oil. Replace the oil completely every six months. Oil level should be 40-50mm measured from the bottom of reservoir. Dispose of worn-out oil in compliance with applicable regulations.
- Check sharpener head stop function. [See Section 5.1.](#)

Monthly:

- Check motor and indexer brushes.
- Check plugs and switches.
- Check the axial run-out and the radial run-out on the motor shaft at the place where the grinding wheel is mounted. Do it once a month, using a dial indicator mounted on a magnetic stand. The maximum allowable run-out must be no greater than $\pm .01$ mm.



CAUTION! Regularly clean or replace oil vapors extractor filter (according to manufacturer's recommendation).

4.2 Blade Sharpening Tips

This section covers some of the common problem areas of blade sharpening.

Before removing from the saw, clean the blade by running the waterlube on the blade for 15 seconds. This will remove most of the sap buildup that would otherwise have to be scraped off when it dries. Wipe with a clean dry rag.

Make sure the flow of oil through the oiler assembly is strong.

Sharpen the blade when it first shows signs of dullness. If the blade is extremely dull, due to hitting a rock or some form of foreign matter, sharpen the blade twice lightly, instead of trying to remove too much in one grind. Grinding too much material at once may cause the circuit breaker in the control box to kick out. If this happens, wait 15 seconds. Then turn it on (push circuit breaker down).

SECTION 5 ALIGNMENT

Align the sharpener monthly to ensure quality performance. Also realign the sharpener as necessary (i.e., after the grinding wheel has been impacted by the index pawl).

5.1 Sharpener Head Stop Alignment

Adjust the distance between blade clamp and grinding wheel using the locking bolt, to avoid hitting the blade clamp with the sharpener head (when there is no blade in the clamp).

Distance between grinding wheel and blade clamp should be 2.0-3.0mm.

Repeat the adjustment monthly.

See **Figure 5-1**. Sharpener head stop adjustment is shown below.

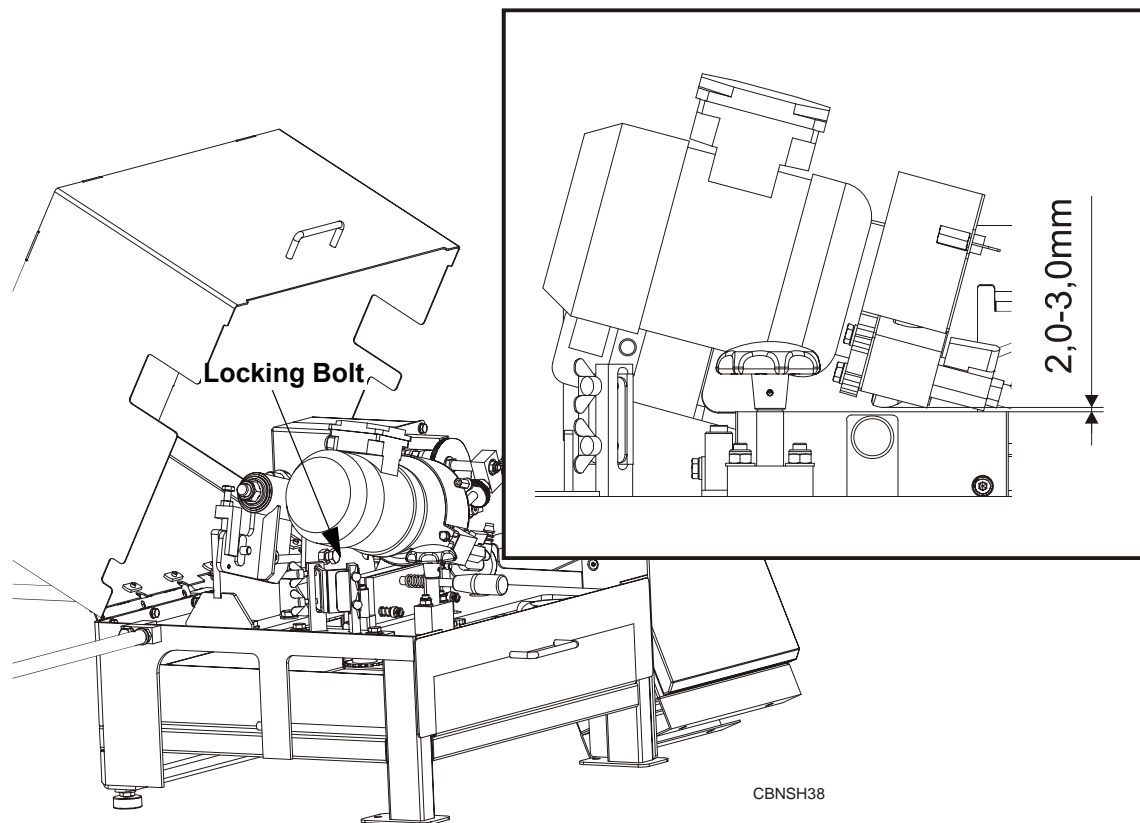

FIG. 5-1

SECTION 6 REPLACEMENT PARTS

6.1 How To Use The Parts List

- Use the table of contents or index to locate the assembly that contains the part you need.
- Go to the appropriate section and locate the part in the illustration.
- Use the number pointing to the part to locate the correct part number and description in the table.
- Parts shown indented under another part are included with that part.
- Parts marked with a diamond (◆) are only available in the assembly listed above the part.

See the sample table below. Sample Part #A01111 includes part F02222-2 and subassembly A03333. Subassembly A03333 includes part S04444-4 and subassembly K05555. The diamond (◆) indicates that S04444-4 is not available except in subassembly A03333. Subassembly K05555 includes parts M06666 and F07777-77. The diamond (◆) indicates M06666 is not available except in subassembly K05555.

Sample Assembly				
REF.	DESCRIPTION (◆ Indicates Parts Available In Assemblies Only)	PART #	QTY.	
	SAMPLE ASSEMBLY, COMPLETE (INCLUDES ALL INDENTED PARTS BELOW)	A01111	1	
1	Sample Part	F02222-22	1	
	Sample Subassembly (Includes All Indented Parts Below)	A03333	1	
2	Sample Part (◆ Indicates Part Is Only Available With A03333)	S04444-4	1	◆
	Sample Subassembly (Includes All Indented Parts Below)	K05555	1	
3	Sample Part (◆ Indicates Part Is Only Available With K05555)	M06666	2	◆
4	Sample Part	F07777-77	1	

To Order Parts:

- From Europe call our European Headquarters and Manufacturing Facility in Kolo, Poland at **+48-63-2626000**. From the continental U.S., call our toll-free Parts hotline at **1-800-448-7881**. Have your customer number, vehicle identification number, and part numbers ready when you call.
- From other international locations, contact the Wood-Mizer distributor in your area for parts.

6.2 Blade Support Assembly

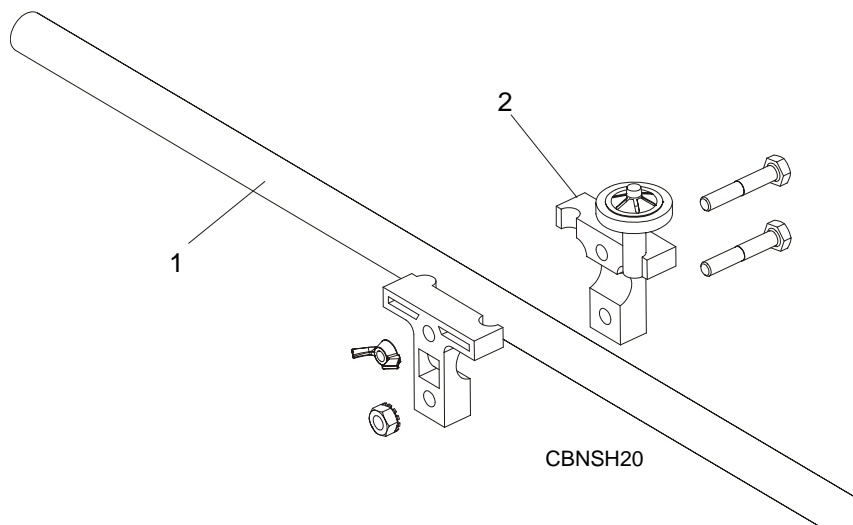

REF.	DESCRIPTION (◆ Indicates Parts Available In Assemblies Only)	PART #	QTY.	
1	BLADE SUPPORT ASSEMBLY, COMPLETE	087518-1	3	
1	GUIDE KIT, BLADE SUPPORT	A10617	1	

6.3 Grinder Assembly

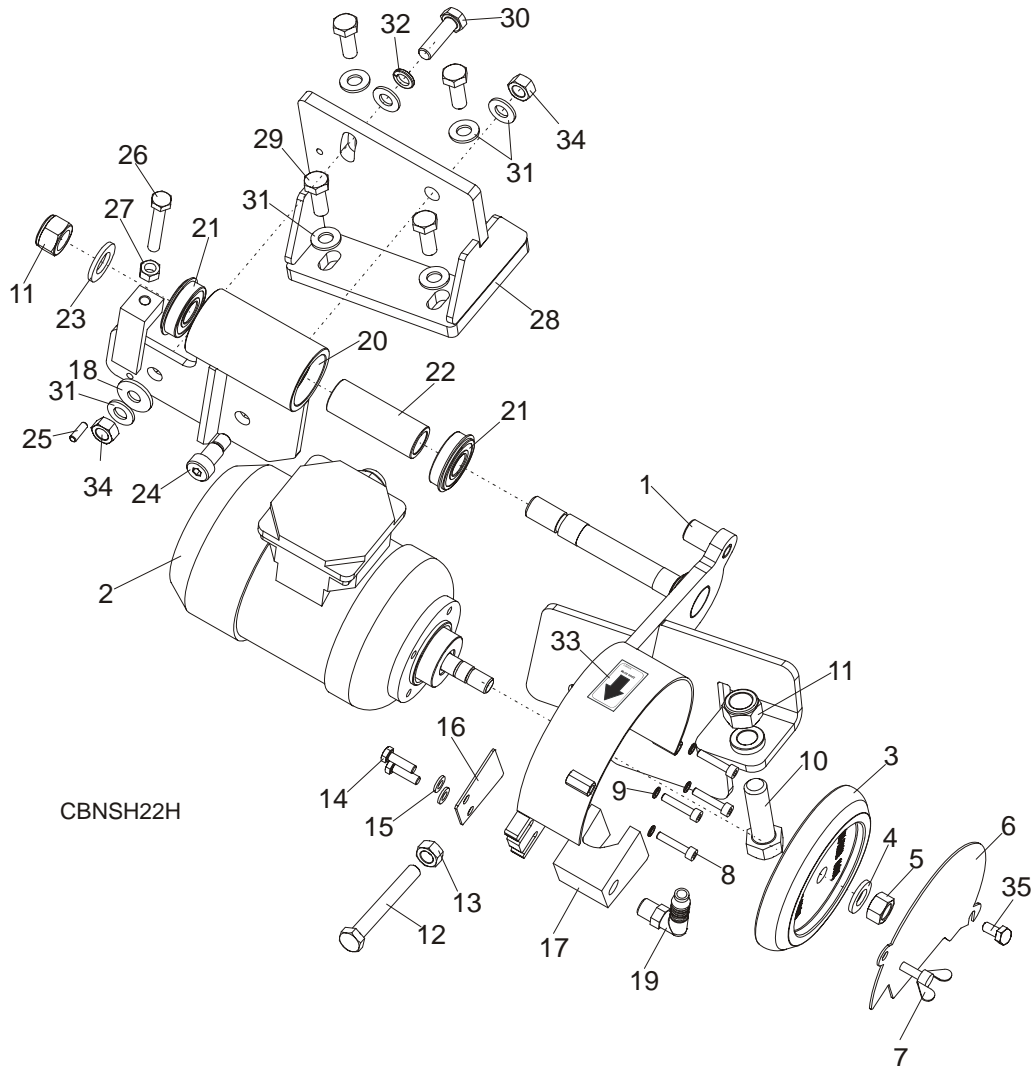

REF.	DESCRIPTION (◆ Indicates Parts Available In Assemblies Only)	PART #	QTY.
	SHARPENER HEAD, PLCBN AC COMPLETE	097030	1
1	Arm, Sharpener Head Weldment	097031-1	1
2	Motor, SEKg 56-2C2/162A 230V 50Hz	089383	1
3	Wheel, 9/29 LTAGA Grinding CBN Profile	030380	1
	Wheel, 10/30 LTAGA Grinding CBN Profile	030381-1	1
	Wheel, 13/29 LTAGA Grinding CBN Profile	030389	1
	Wheel, 4/32 LTAGA Grinding CBN Profile	050145	1
4	Washer, M12 Flat Zinc	F81056-1	1
5	Nut, M12x1,25-8 Hex Zinc	F81034-8	1
6	Cover, Front Guard	088247-1	1
7	BOLT, M6X16 BN276	F81001-16	1
8	Screw, M5x25 -8.8 Hex Socket Head Cap Zinc	F81000-7	4
9	Washer, 10.2 Split Lock Zinc	F81055-2	1
10	Bolt, M16x50-8.8 Hex Flat Head	F81006-38	1
11	Nut, M16-8 Hex Nylon Zinc Lock	F81036-2	2
12	Bolt, M10-80-8.8 Fe/Zn5 Hex Head Full Thread	F81003-76	1

13	Nut, M10 -8-B Hex Zinc	F81033-3	1	
14	Bolt, M6x20-8.8 Hex Head Full Thread Zinc	F81001-2	2	
15	Washer, 6.4 Flat Zinc	F81053-1	2	
16	Washer, Oiler Spacer	094060-1	1	
17	Oiler, Sharpener	093193	1	
18	WASHER,10.5 Zinc Flat Special	F81055-6	1	
19	Stud, WES 10/R 1/4 Elbow	088379	1	
20	Bushing, Sharpener Vertical Pivot	088339-1	1	
21	Bearing w/Ring	086395	2	
22	Bushing, Sharpener Head Spacer	092672	1	
23	Washer, 17 Flat Zinc	F81058-1	1	
24	Screw, 12/M10x16 12.9 Bossard Socket Head Shoulder	F81003-64	1	
25	Pin, 5x16 Roll Fe/Zn Zinc	F81044-3	1	
26	Bolt, M8x50 - 8.8 Hex Head Full Thread Zinc	F81002-19	1	
27	Nut, M8 Hexagon, Grade 5.8 Free Zinc	F81032-1	1	
28	Base Weldment, Sharpener Head	088400-1	1	
29	Bolt, M10X25-8.8-Fe/Zn5	F81003-11	4	
30	Bolt, M10x35 - 8.8 Hex Head Full Thread Zinc	F81003-17	4	
31	Washer, 10.5 Flat Zinc	F81055-1	3	
32	Washer, 5.1 Split Lock Zinc	F81052-2	4	
33	DECAL, 2800 RPM Motor Rotation Direction	S20097C ¹	1	
34	NUT,M10-8-B Nylon Hex Zinc Lock	F81033-1	2	
35	BOLT, M6x12-8.8 Hex Head Full Thread Zinc	F81001-7	1	

¹ Belongs to 088855 - LTAGA-PLCBN Decal Kit.

6.4 Sharpener Mounting Plate

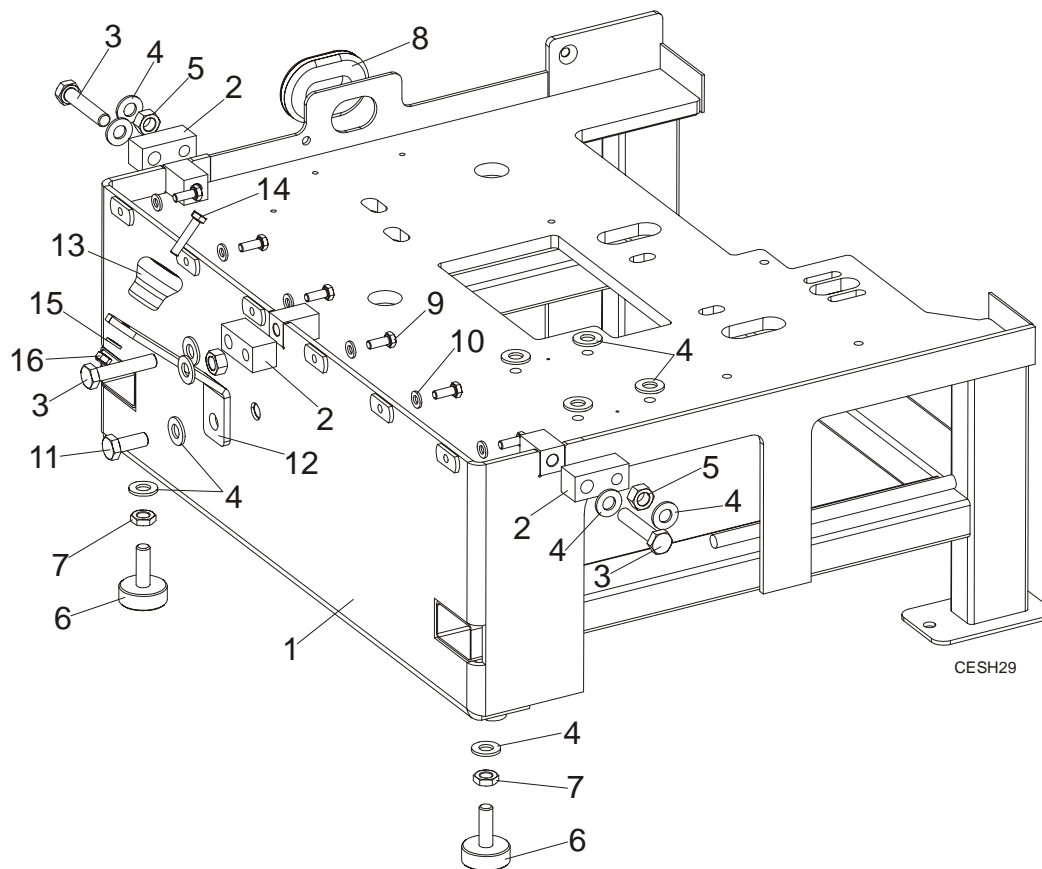

REF.	DESCRIPTION (◆ Indicates Parts Available In Assemblies Only)	PART #	QTY.
1	PLATE, PLCBN AC SHARPENER MOUNTING	097029-1	1
2	ARM, BLADE MOUNTING PTD	093183-1	3
3	BOLT, M10X50MM, HEX HEAD FULL THRD ZINC	F81003-4	3
4	WASHER, 10.5 FLAT ZINC	F81055-1	13
5	NUT, M10-8-B-FE	F81033-3	3
6	FOOT, BASE ADJUST	092839	2
7	NUT, 10MM X 1.25 NYLON	F81033-6	2
8	SEAL RUBBER, WIRE INSIDE DIA 26MM	085613	1
9	BOLT, M6X16 8.8 HEX HEAD FULL THREAD ZINC	F81001-15	6
10	WASHER, 6.4 FLAT ZINC	F81053-1	6
11	BOLT, M10X25-8.8-FE/ZN5	F81003-11	1
	BRACKET, CBN-AC COVER WELDMENT	087824	1
12	Bracket, Cover Weldment	087826-1	1
13	Bumper, Cover Bracket	087825	1
14	Bolt, M6x30 5.8 Hex Zinc	F81001-13	1
15	Washer, 6.4 Flat Zinc	F81053-1	1
16	Nut, M6-8-B Hex Nylon Zinc Lock	F81031-2	1

6.5 Blade Clamp Assembly

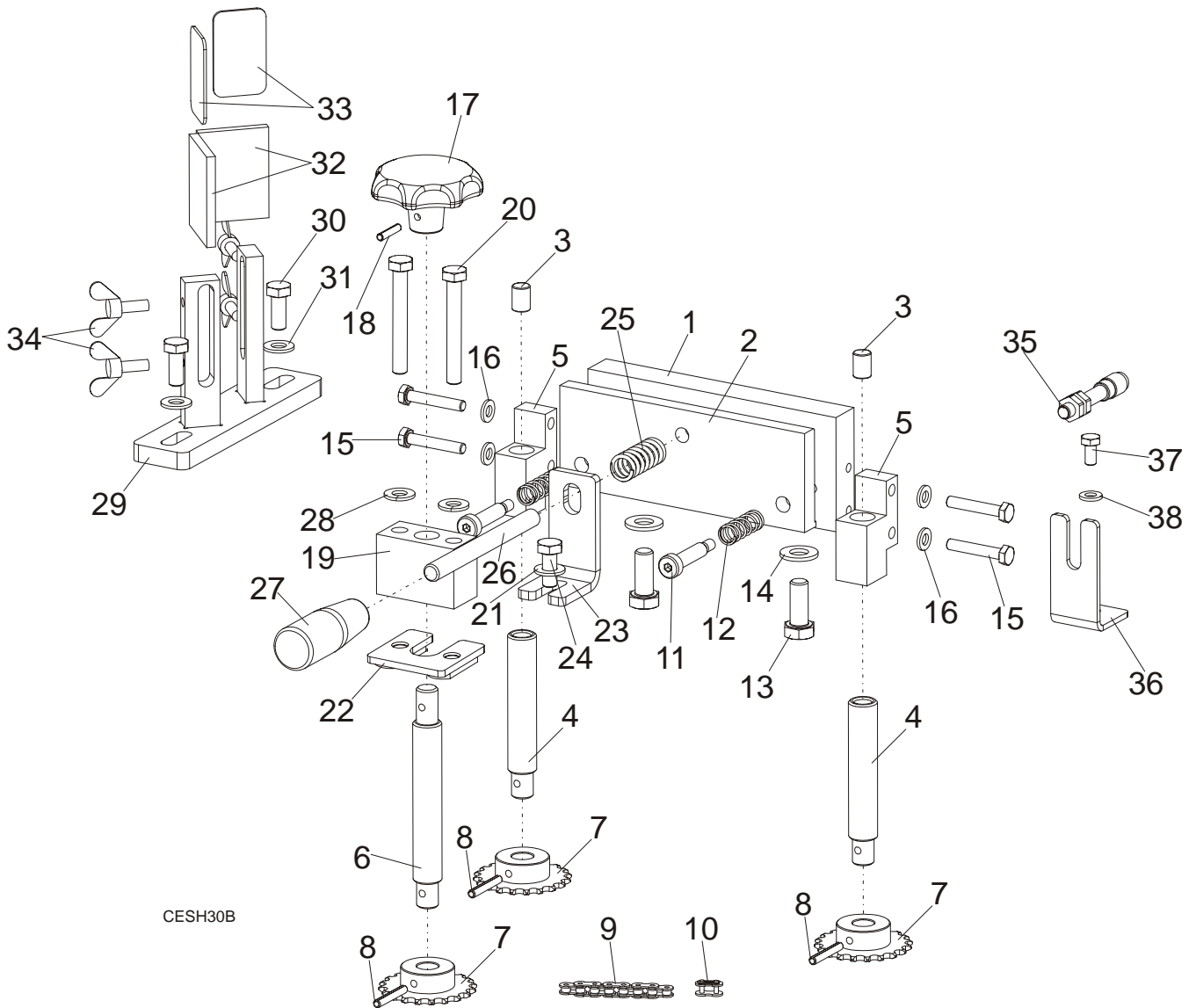

CESH30B

REF.	DESCRIPTION (◆ Indicates Parts Available In Assemblies Only)	PART #	QTY.
	BLADE CLAMP WITH BLADE HEIGHT ADJUSTMENT	098512	1
1	PLATE, FIXED CLAMP ZINC-PLATED	097025-1	1
2	PLATE, MOVING CLAMP ZINC-PLATED	097026-1	1
3	ROLLER, φ10x14 CYLINDRICAL	096864	2
4	SCREW, BLADE HEIGHT ADJUSTMENT ZINC-PLATED	096865-1	2
5	BLOCK, THREADED ZINC-PLATED	096866-1	1
6	SCREW, BLADE HEIGHT ADJUSTMENT DRIVING ZINC-PLATED	096867-1	1
7	SPROCKET, 05B-1 Z20 8x3-12H7 ZINC-PLATED	098513-1	3
8	PIN, 4X30 SPRING-TYPE STRAIGHT ZINC-PLATE	F81044-7	3
	CHAIN, BLADE HEIGHT ADJUSTMENT - COMPLETE	098515	1
9	CHAIN, 05B-1-73 DRIVING	098516	1
10	LINK, QRC05B-1 MASTER	098517	1

11	SCREW, 8/M6X30-12.9 SOCKET HEAD SHOULDER	F081001-18	2	
12	SPRING, 9X30X1.2 COMPRESSION	088368	2	
13	BOLT, M10X25-8.8 HEX HEAD FULL THREAD ZINC	F81003-11	2	
14	WASHER, 10.5 FLAT ZINC	F81055-1	2	
15	BOLT, M6x35 8.8 HEX HEAD ZINC	F81001-71	4	
16	WASHER, 6.4 FLAT ZINC	F81053-1	4	
17	KNOB, DIN6336-GG-63-B12-C BLADE HEIGHT ADJUSTMENT	098514	1	
18	PIN, PN-EN ISO8752-4X20 ST AOP ROLL	F81044-11	1	
19	BLOCK, ADJUSTMENT KNOB MOUNTING ZINC-PLATED	097062-1	1	
20	BOLT, M8X60-8.8 HEX HEAD ZINC	F81002-54	2	
21	WASHER, 8.4 FLAT ZINC	F81054-1	1	
22	NUT, M8 DOUBLE ZINC	503104-1	1	
23	BRACKET, BLADE CLAMP SPRING	097069-1	1	
24	BOLT, M8X20-5.8 HEX HEAD FULL THREAD ZINC	F81002-1	1	
25	SPRING	087376	1	
26	STUD-BOLT, 1M10X90-8.8-FE/ZN5	F81003-85	1	
27	GRIP, L70 THREAD M10 13870M10	089445	1	
28	WASHER, 8.2 SPLIT LOCK ZINC	F81054-4	2	
	COMPLETE BLADE WIPER	098526	1	
29	BRACKET WELDMENT, BLADE WIPER MOUNT	092770-1	1	
30	BOLT, M8X20-5.8 HEX HEAD FULL THREAD ZINC	F81002-1	2	
31	WASHER, 8.4 FLAT ZINC	F81054-1	2	
32	WIPER, FLEXAM 3T2862 BLADE	087608	2	
33	BRACE, BLADE WIPER	088098-1	2	
34	SCREW, M6X16 DIN 316 THUMB	F81001-16	4	
35	INDUCTIVE SENSOR 48VDC 200MA XS+OPTIONS (not in LTAGA-PLCBN EC Version)	088268	1	
36	BRACKET, MAGNETIC SHUTOFF SENSOR MOUNT (not in LTAGA-PLCBN EC Version)	088366-1	1	
37	BOLT, M6X12MM HEX HEAD ZINC (not in LTAGA-PLCBN EC Version)	F81001-7	1	
38	WASHER, 6.4 FLAT ZINC (not in LTAGA-PLCBN EC Version)	F81053-1	1	

6.6 Oil Pump/Pan

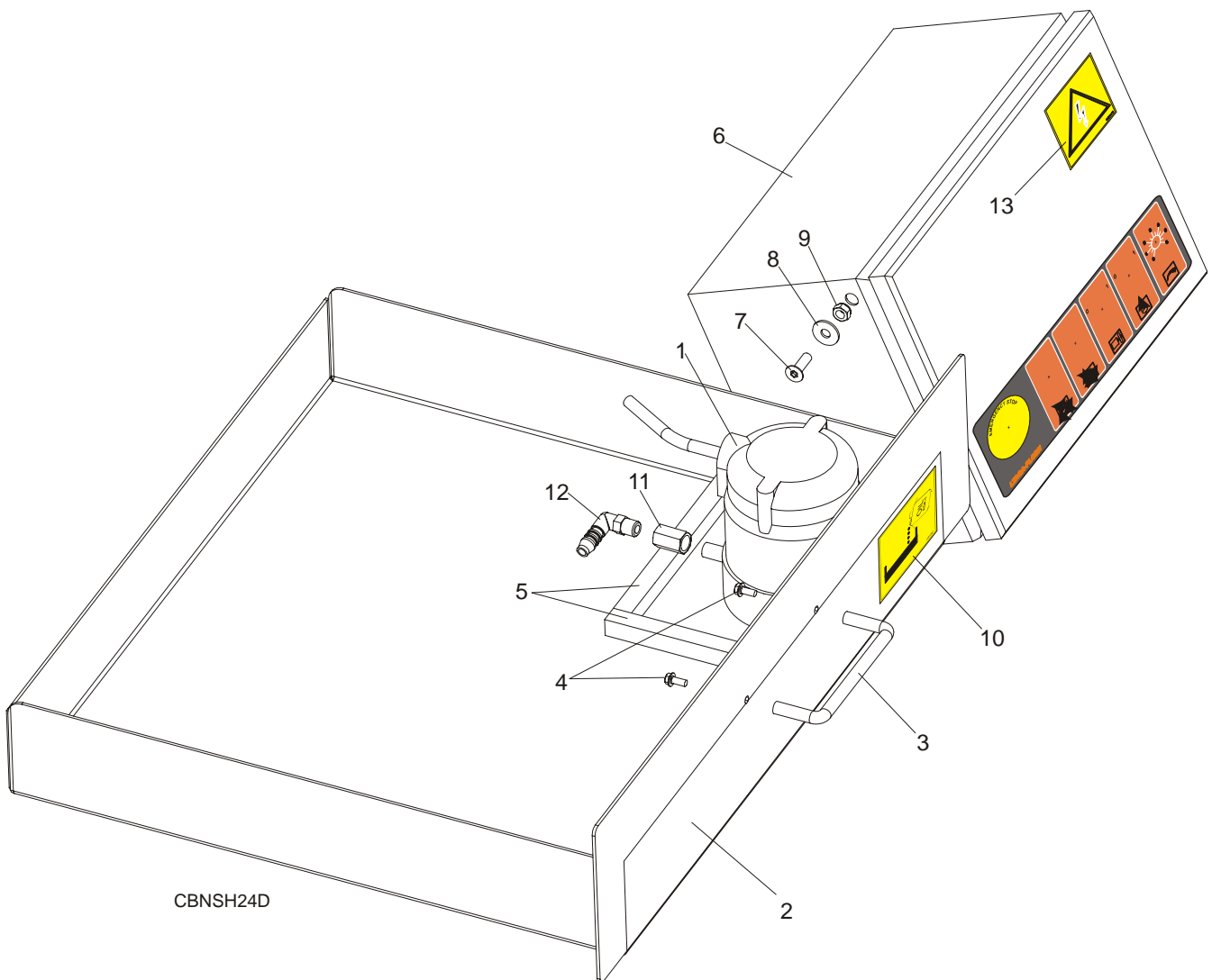

REF.	DESCRIPTION (◆ Indicates Parts Available In Assemblies Only)	PART #	QTY.
1	PUMP, AUTO SHARPENER COOLANT	P09836	1
2	PAN, SHARPENER OIL	088201	1
3	HANDLE, 4" W/BOLTS	P08065	1
4	BOLT, #8-32X3/8	F05018-5	2
5	MAGNET, OIL FILTER	P31347	2
6	BOX, CBN SHARPENER CONTROL	092628	1
	BOX, LTAGA-PLCBN EC SHARPENER CONTROL	507241	1
7	SCREW, M6X20-10.9 FE/ZN5 DIN-7991	F81001-17	2
8	WASHER, 6.5 FLAT ZINC	F81053-11	2
9	NUT, M6-8-B HEX NYLON ZINC LOCK	F81031-2	2
10	DECAL - „OIL" PICTOGRAM	095961 ¹	1
11	FITTING, 1/4 F.TH./1/4 F.TH.893-302-000-4	090808	1
12	STUD, WES 10/R 1/4 ELBOW	088379	1
13	DECAL, ELECTRIC POWER WARNING	S10364-P3 ¹	1

¹ Belongs to 088855 - LTAGA-PLCBN Decal Kit.

6.7 Cam Assembly

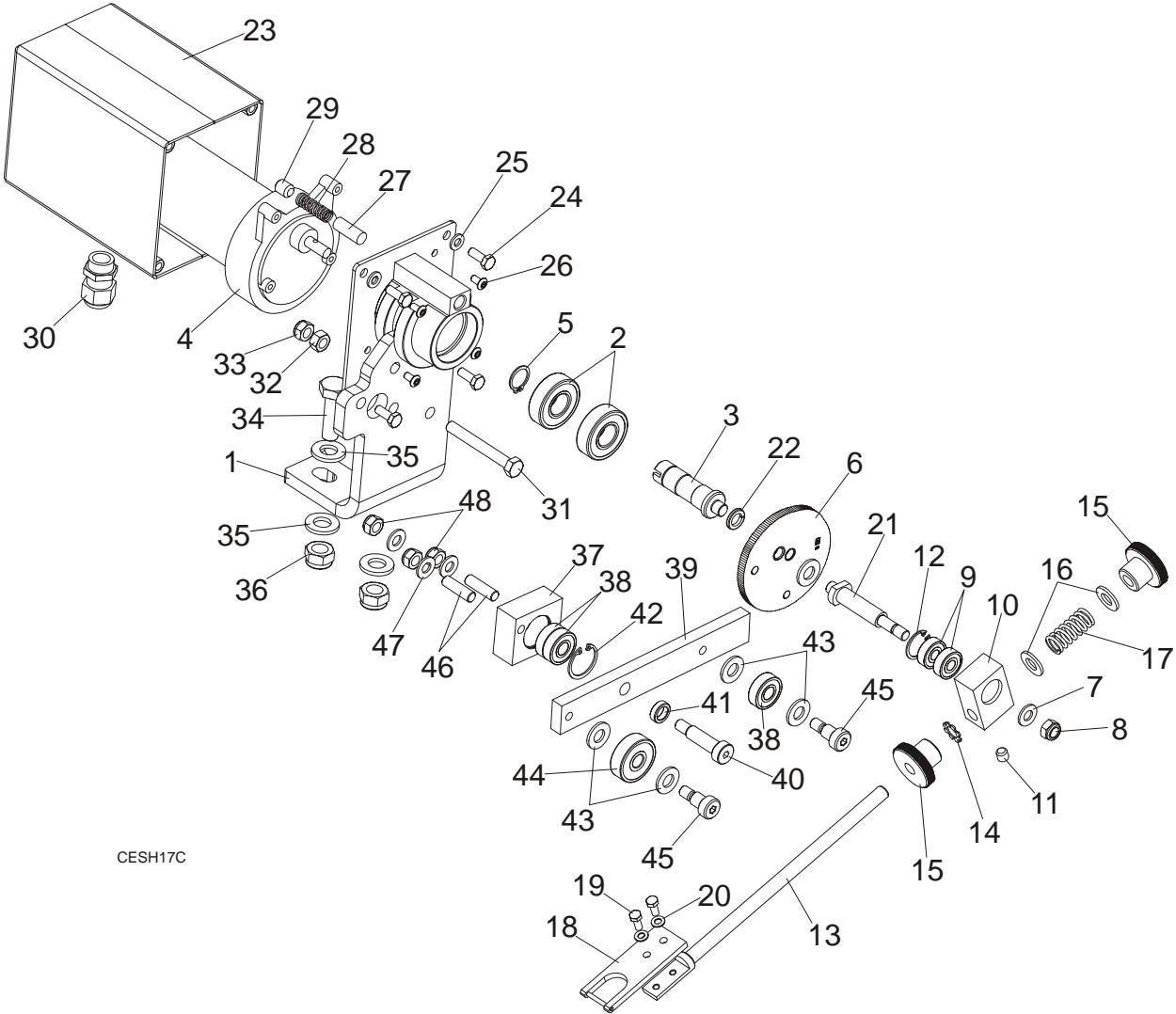

CESH17C

REF.	DESCRIPTION (◆ Indicates Parts Available In Assemblies Only)	PART #	QTY.
	CAM & INDEX ARM DRIVE ASSEMBLY, COMPLETE	098520	1
1	HOUSING WDMT, INDEX CAM DRIVE SHAFT PTD	087371-1	1
2	BEARING, 6203-2RS	086114	2
3	SHAFT, CAM DRIVE	087366	1
4	MOTOR, 1/30HP 62RPM 12VDC 53:1 GEAR	P09698-1	1
5	SNAP RING PN-M/85111	F81090-21	1
6	CAM, AGA PROFILE	010741	1
7	WASHER, 8.4 FLAT ZINC	F81054-1	1
8	NUT, M8-8-B HEX NYLON ZINC LOCK	F81032-2	1
9	REPAIR KIT, SHARPENER INDEXER	097462	1
	BEARING, 608-2RS ROLLER	086197	2

10	BLOCK, INDEX - ZINC	087373-1	1	
11	SCREW, M8X8-33H HEX SOCKET SET FLAT POINT	F81014-1	1	
12	RING, W22 RETAINING	F81090-7	1	
13	PAWL WELDMENT, BLADE INDEX - ZINC	087374-1	1	
14	WASHER, 10.5 EXTERNAL RING	F81055-3	1	
15	WASHER, PUSH PAWL	087375	2	
16	WASHER, 10.5 FLAT ZINC	F81055-1	3	
17	SPRING, INDEX ARM	087376	1	
18	PUSHER, BLADE COMPLETE	093358	1	
19	BOLT, M5 X 12-5.8 HEX HEAD FULL THREAD ZINC	F81000-5	2	
20	WASHER, 5.3 FLAT ZINC	F81052-1	2	
21	SHAFT, INDEX CAM - ZINC	087372-1	1	
22	WASHER, 10.2 SPLIT LOCK ZINC	F81055-2	1	
23	GUARD, INDEX ARM MOTOR	097120-1	1	
24	BOLT, M6 x 16 8.8 Fe/Zn5 PN-M/82105	F81001-15	4	
25	WASHER, 6.4 FLAT ZINC	F81053-1	4	
26	SCREW, 10-32X3/8 SBHC	F05004-56	4	
27	PIN, CAM BRAKE	S10663	1	
28	SPRING, LC-045E-12	P04734	1	
29	SCREW, M12x12-33H HEX SOCKET FLAT POINT	F81004-15	1	
30	GLAND NUT, TRAILER HITCH, DW 11/H	085388	1	
31	BOLT, M8 X 65MM, HH, GRADE 5.8, ZINC	F81002-3	1	
32	NUT, M8 HEXAGON, GRADE 5.8 FREE ZINC	F81032-1	1	
33	NUT, M8-8-B HEX NYLON ZINC LOCK	F81032-2	1	
34	BOLT, M12x40 8.8 HEX HEAD FULL THR.ZINC	F81004-4	2	
35	WASHER, 13 FLAT ZINC	F81056-1	4	
36	NUT, M12-8 HEX NYLON ZINC LOCK	F81034-2	2	
	COMPLETE CAM LEVER	098522	1	
37	HOUSING, CAM LEVER BEARINGS ZINC-PLATED	098523-1	1	
38	BEARING, 6000 . 2RSR FAG	087471	3	
39	LEVER, CAM ZINC-PLATED	098521-1	1	
40	BOLT, 10/M8X30 12.9 ISO 7379 SHOULDER	F81003-81	1	
41	BUSHING, CAM LEVER SPACER ZINC-PLATED	098524-1	1	
42	RING, W26 PN/M-85111 INSIDE RETAINING	F81090-34	1	
43	WASHER, 10.5 FLAT ZINC	F81055-1	4	
44	BEARING, 6300.2 RSR CX	098519	1	
45	BOLT, 10/M8 X 12-12.9 ISO-7379	F81003-62	2	
46	STUD-BOLT, 1 M8X20-8.8 ZINC-PLATED	F81002-38	2	
47	WASHER, 8.4 FLAT ZINC	F81054-1	3	
48	NUT, M8-8-B HEX NYLON ZINC LOCK	F81032-2	3	

6.8 Cover Assembly

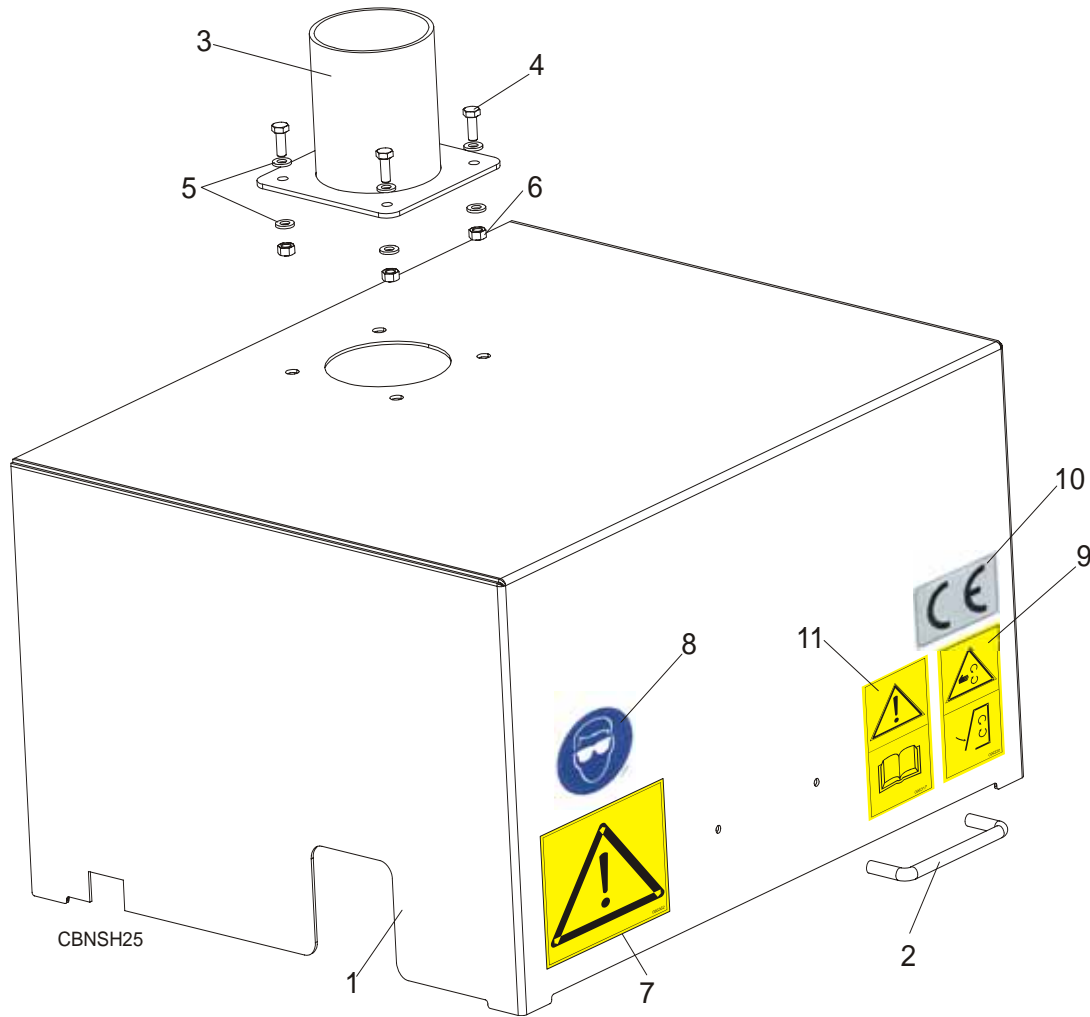

REF.	DESCRIPTION (◆ Indicates Parts Available In Assemblies Only)	PART #	QTY.
	SHARPENER COVER, COMPLETE (not in LTAGA-PLCBN EC Version)	088302	1
1	Cover Weldment	088254-1	1
2	Handle w/Bolts	P08065	1
3	Pipe, Fume Exhaust Connection	087974-1	1
4	Bolt, M6x16 8.8 Hex Head Full Thread Zinc	F81001-15	4
5	Washer, 6.4 Flat Zinc	F81053-1	8
6	Nut, M6 –8 Hex Zinc	F81031-1	4
7	DECAL, GENERAL WARNING	086362 ¹	1
8	DECAL, EYE WARNING, SMALL	S12004G-1 ¹	1
9	DECAL , CLOSE ALL GUARDS BEFORE OPERATING	099220 ¹	1
10	DECAL, CE CERTIFIED SAWMILL - SAMLL	P85070 ¹	1
11	DECAL, READ OPERATOR'S MANUAL (PICTOGRAM)	096317 ¹	1

¹ Belongs to 088855 - LTAGA-PLCBN Decal Kit.

6.9 Alignment Tool

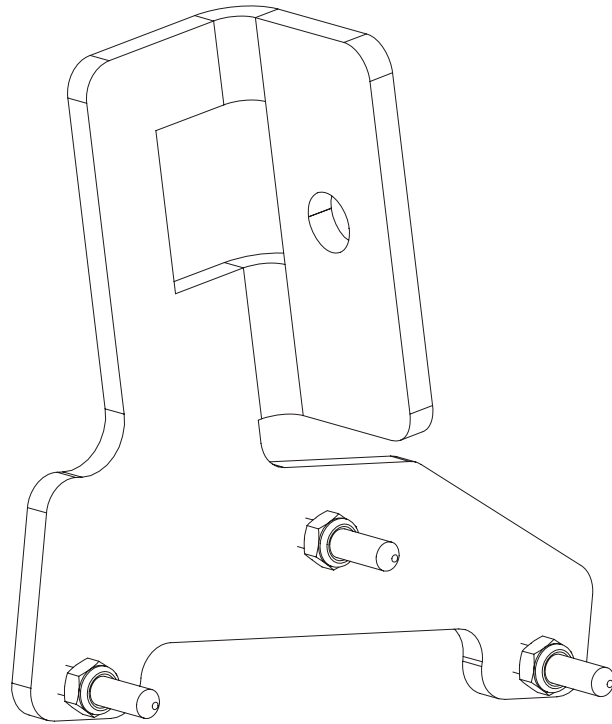

REF.	DESCRIPTION (◆ Indicates Parts Available In Assemblies Only)	PART #	QTY.	
	HOOK ANGLE TEMPLATE, SHARPENER	088382	1	

SECTION 7 ELECTRICAL INFORMATION

7.1 Electrical Diagram, LTAGAE-SA 230V 50 Hz

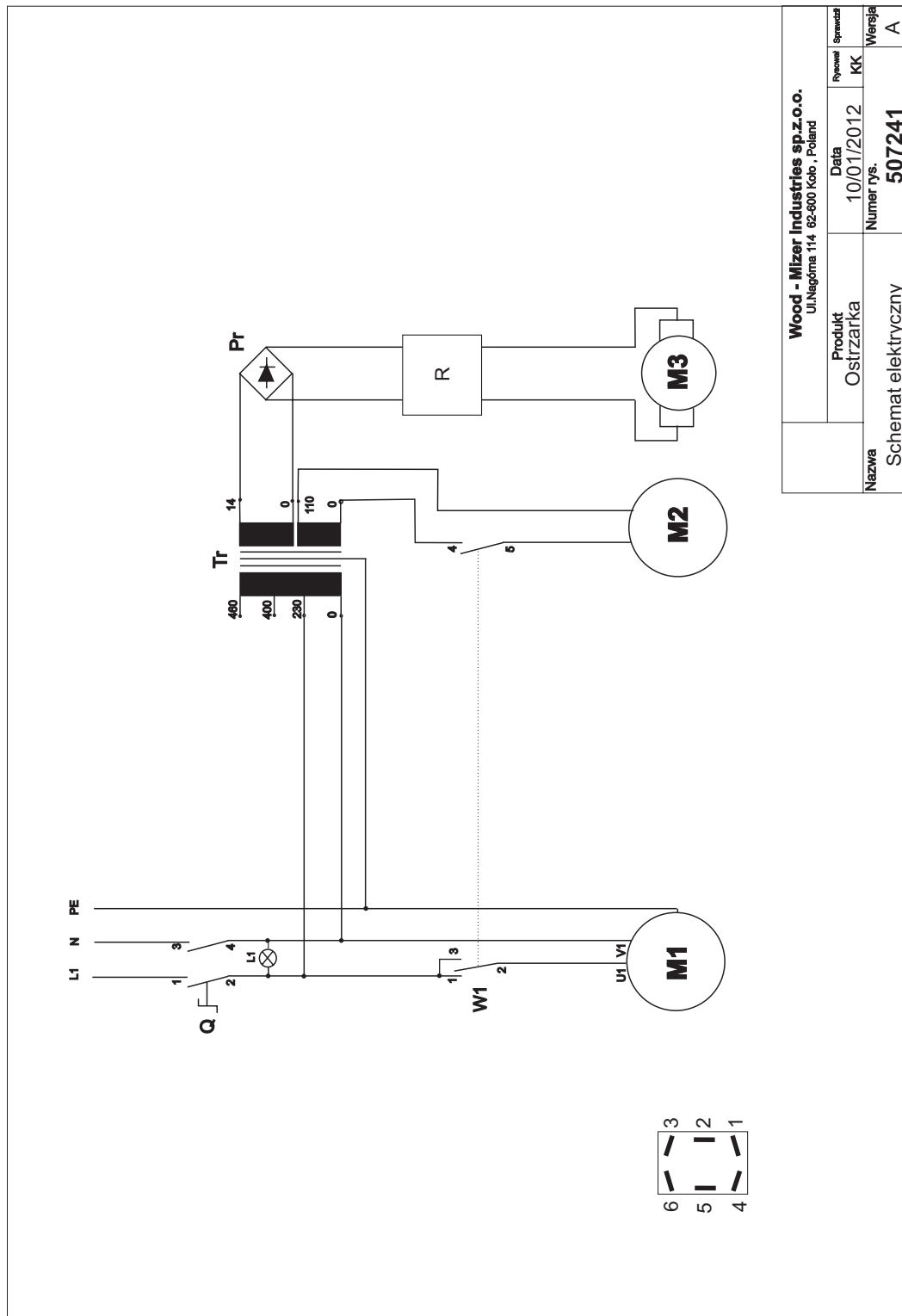

FIG. 7-1

7.2 Electrical Components, LTAGAE-SA 230V 50 Hz

Symbol	Manufacturer	Wood-Mizer Part No.	Description
Q +L1			Switch, Power (Illuminated)
R	Sobanski	088837	Dial, H166-1 Feed Rate
PR		084318	Bridge, KBPC 3508 Rectifier
W1	CARLING	024588	Switch, DPDT ON/OFF/ON 15A Toggle
Tr	Indel	500631	Transformer, SU96C-230311
M1	Besel	087769	Motor, SEKg56 2C2 Grinder
M2	USA	P09836	Pump, Coolant
M3	USA	P09698-1	Motor, 1/30HP 62RPM 12VDC 53:1 Gear

7.3 Electrical Diagram, LTAGAE-UA 230V 60 Hz

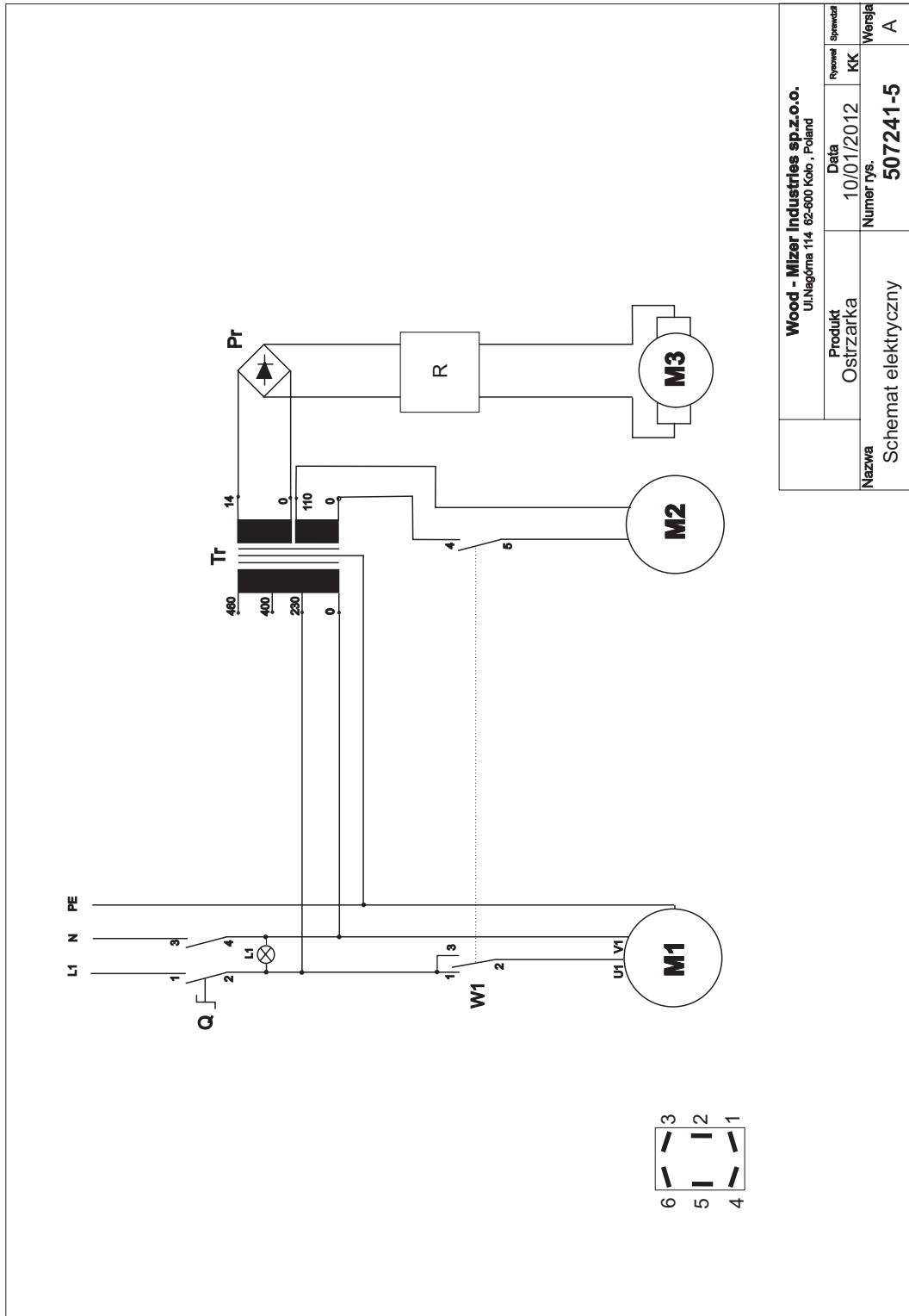

FIG. 7-2

7.4 Electrical Components, LTAGAE-UA 230V 60 Hz

Symbol	Manufacturer	Wood-Mizer Part No.	Description
Q +L1			Switch, Power (Illuminated)
R	Sobanski	088837	Dial, H166-1 Feed Rate
PR		084318	Bridge, KBPC 3508 Rectifier
W1	CARLING	024588	Switch, DPDT ON/OFF/ON 15A Toggle
Tr	NORATEL	500631	Transformer, SU96C-230311
M1	Besel	089383-UL	Motor, SEKg56 2C2 Grinder
M2	USA	P09836	Pump, Coolant
M3	USA	P09698-1	Motor, 1/30HP 62RPM 12VDC 53:1 Gear

7.5 Electrical Diagram, LTAGAE-UM 110V 60 Hz

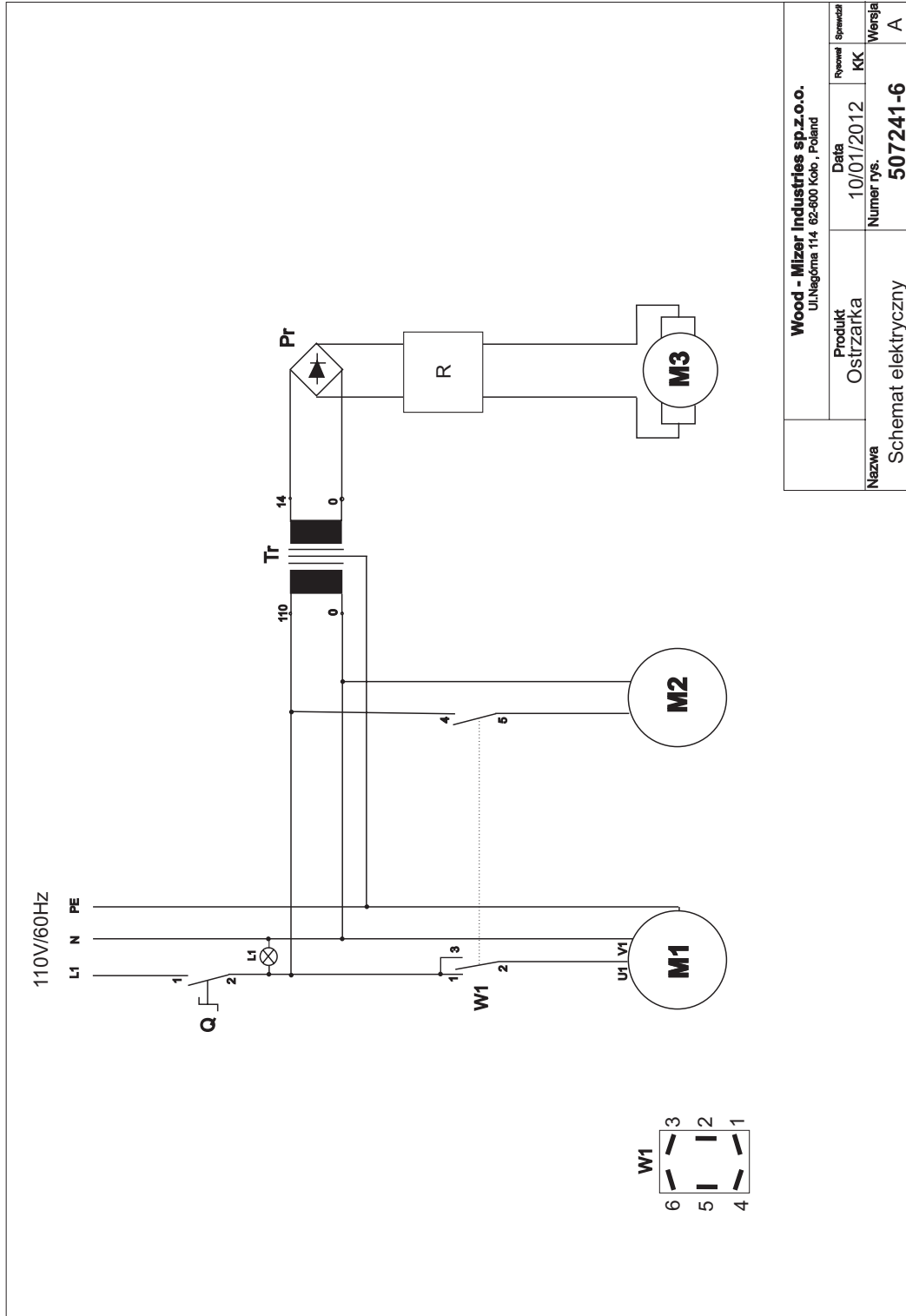

FIG. 7-3

7.6 Electrical Components, LTAGAE-UM 110V 60 Hz

Symbol	Manufacturer	Wood-Mizer Part No.	Description
Q +L1			Switch, Power (Illuminated)
R	Sobanski	088837	Dial, H166-1 Feed Rate
PR		084318	Bridge, KBPC 3508 Rectifier
W1	CARLING	024588	Switch, DPDT ON/OFF/ON 15A Toggle
Tr	Noratel	093491	Transformer, SU78A-11014
M1	Besel	093490-UL	Motor, SEKg56 2C2 Grinder
M2	USA	P09836	Pump, Coolant
M3	USA	P09698-1	Motor, 1/30HP 62RPM 12VDC 53:1 Gear

7.7 Electrical Diagram, LTAGAP-SA 230V 50 Hz

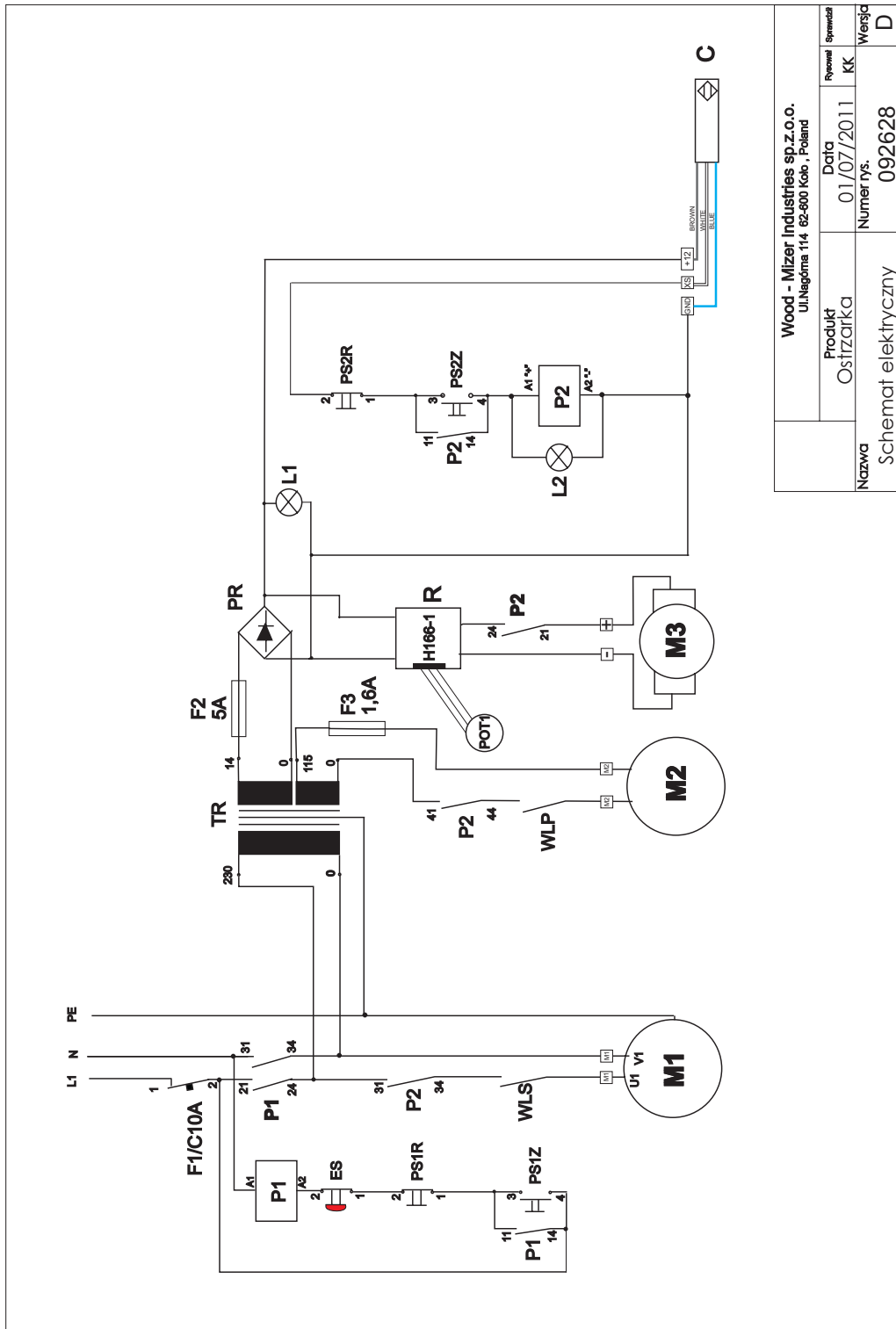
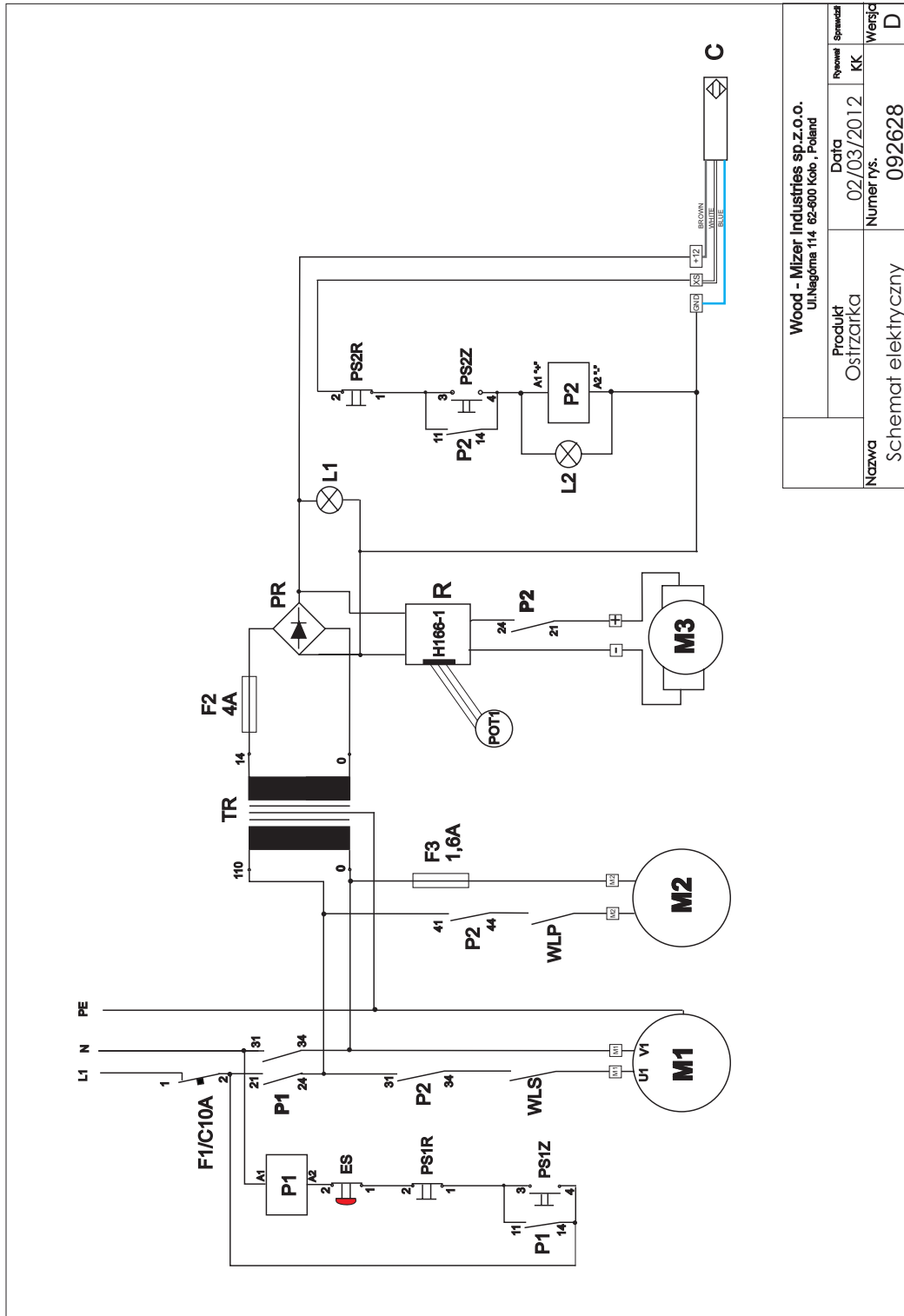

FIG. 7-4

7.8 Electrical Components, LTAGAP-SA 230V 50 Hz

Symbol	Manufacturer	Wood-Mizer Part No.	Description
P2	Finder	091951	Relay, Finder Type 55.33.9.012.00.10
P1	Finder	090987	Relay, Finder Type 55.33.8.230.00.10
F2			Fuse, 5A Glass
F3			Fuse, 1.6A Glass
R+POT1	Sobanski	088837	Dial, H166-1 Feed Rate w/Potentiometer
PR			Bridge, KBPC 1008 Rectifier
C1			Capacitor, 2200uF/25V Electrolytic
PCB	Sobanski	084784	PCB – w/o: P1,P2,F2,F3,R+POT1
F1	Schneider	088283	Breaker, C60N C10 24401 Circuit
ES	Schneider	502315	Button, XB7 ES542P Emergency Stop
WLS	Schneider		Switch, Grinder Motor
WLP	Schneider		Switch, Coolant Pump
PS1, PS2	Schneider		Switch, START – STOP Complete
L1,L2	Schneider		LED, START-STOP Switch
Tr	Indel	090988	Transformer, TMB160/015M/1
M1	Besel	087769	Motor, SEKg56 2C2 Grinder
M2	USA	P09836	Pump, Coolant
M3	USA	P09698-1	Motor, 1/30HP 62RPM 12VDC 53:1 Gear
C	Balluff	088268	Sensor, BES M08EG-POC40F-BV02 Inductive Proximity

7.9 Electrical Diagram, LTAGAP-UA 230V 60 Hz



Wood - Mizer Industries sp.z.o.o. Ul. Nagórna 114 62-800 Koto, Poland		Przebieg	Sprawdz
Produkt	Ostizarka	Data	02/03/2012
Nazwa	Schemat elektryczny	Numer rys.	092628
			Wersja
			D

FIG. 7-5

7.10 Electrical Components, LTAGAP-UA 230V 60 Hz

Symbol	Manufacturer	Wood-Mizer Part No.	Description
P2	Finder	091951	Relay, Finder Type 55.33.9.012.00.10
P1	Finder	090987	Relay, Finder Type 55.33.8.230.00.10
F2			Fuse, 5A Glass
F3			Fuse, 1.6A Glass
R+POT1	Sobanski	088837	Dial, H166-1 Feed Rate w/Potentiometer
PR			Bridge, KBPC 1008 Rectifier
C1			Capacitor, 2200uF/25V Electrolytic
PCB	Sobanski	084784	PCB – w/o: P1,P2,F2,F3,R+POT1
F1	Schneider	088283	Breaker, C60N C10 24401 Circuit
ES	Schneider	502315	Button, XB7 ES542P Emergency Stop
WLS	Schneider		Switch, Grinder Motor
WLP	Schneider		Switch, Coolant Pump
PS1, PS2	Schneider		Switch, START – STOP Complete
L1,L2	Schneider		LED, START-STOP Switch
Tr	NORATEL	500631	Transformer, SU96C-230311
M1	Besel	089383-UL	Motor, SEKg56 2C2 Grinder
M2	USA	P09836	Pump, Coolant
M3	USA	P09698-1	Motor, 1/30HP 62RPM 12VDC 53:1 Gear
C	Balluff	088268	Sensor, BES M08EG-POC40F-BV02 Inductive Proximity

7.12 Electrical Components, LTAGAP-UM 110V 60 Hz

Symbol	Manufacturer	Wood-Mizer Part No.	Description
P2	Finder	091951	Relay, Finder Type 55.33.9.012.00.10
P1	Finder	090987-4	Relay, Finder Type 55.33.8.110.00.10
F2			Fuse, 5A Glass
F3			Fuse, 1.6A Glass
R+POT1	Sobanski	088837	Dial, H166-1 Feed Rate w/Potentiometer
PR			Bridge, KBPC 1008 Rectifier
C1			Capacitor, 2200uF/25V Electrolytic
PCB	Sobanski	084784	PCB – w/o: P1,P2,F2,F3,R+POT1
F1	Schneider	088283	Breaker, C60N C10 24401 Circuit
ES	Schneider	502315	Button, XB7 ES542P Emergency Stop
WLS	Schneider		Switch, Grinder Motor
WLP	Schneider		Switch, Coolant Pump
PS1, PS2	Schneider		Switch, START – STOP Complete
L1,L2	Schneider		LED, START-STOP Switch
Tr	Noratel	093491	Transformer, SU78A-11014
M1	Besel	093490-UL	Motor, SEKg56 2C2 Grinder
M2	USA	P09836	Pump, Coolant
M3	USA	P09698-1	Motor, 1/30HP 62RPM 12VDC 53:1 Gear
C	Balluff	088268	Sensor, BES M08EG-POC40F-BV02 Inductive Proximity

EC declaration of conformity according to EC Machinery Directive 2006/42/EC

We herewith declare,

Wood-Mizer Industries sp. Z O.O.
114 Nagorna street, 62-600 Kolo; Poland.

That the following described machine in our delivered version complies with the appropriate basic safety and health requirements of the EC Machinery Directive 2006/42/EC based on its design and type, as brought into circulation by us. In case of alteration of the machine, not agreed by us, this declaration is no longer valid.

Designation of the machine: **INDUSTRIAL SHARPENER**

TYPE: LTAGA-PLCBN

No. of manufacturer:

Applicable EC Directives: EC Machinery Directive 2006/42/EC
EC Low-Voltage Directive 73/23/EEC
EC Electromagnetic Compatibility Directive
2004/108/EC

Used harmonized standards: EN 291-1, EN 292-2, EN 294, EN 563,
EN 60204-1, EN 61000-6-3

Responsible for Technical Documentation: Roman Frontczak / R&D Director

Date/Authorized Signature: 29. 12. 2009



Title : R&D Director