

Wood-Mizer®

Safety, Operation, Maintenance and Parts Manual

Industrial Sharpener

BMS500 Rev. A1.05

BMS600 Rev. A1.04



Safety is our #1 concern! Read and understand all safety information and instructions before operating, setting up and/or maintaining this machine.

May 2009

Table of Contents

Section-Page

SECTION 1	SAFETY & GENERAL INFORMATION	1-1
1.1	Electrical Safety.....	1-2
1.2	Blade Handling.....	1-2
1.3	Machine Operation	1-2
1.4	Sharpener Components.....	1-3
1.5	Overall Dimensions	1-4
1.6	Noise Level.....	1-5
1.7	Motor Specifications	1-5
1.8	Technical Data.....	1-6
1.9	Control Panel Components.....	1-7
1.10	Safety Decals Description	1-10
SECTION 2	SETUP & OPERATION	2-1
2.1	Starting the Machine.....	2-1
2.2	Blade Support Arms Installation	2-3
2.3	Blade Height Adjustment	2-4
2.4	Sharpener Alignment.....	2-6
2.5	Drive Belt Tension	2-8
2.6	Grinding Wheel Installation	2-9
2.7	Blade Installation.....	2-9
2.8	Face Grind Adjustment.....	2-10
2.9	Grind Depth Adjustment	2-12
2.10	Index Arm Stroke Adjustment.....	2-13
2.11	Oil Flow Adjustment	2-14
2.12	Feed Rate Adjustment	2-14
2.13	Blade Rejection	2-14
2.14	Sharpener Operation.....	2-15
2.15	Shutoff	2-15
2.16	3" Blade Support Setup (Option).....	2-16
SECTION 3	REPLACEMENT OF COMPONENTS	3-1
3.1	Grinding Wheel Replacement	3-1
3.2	Oil Level.....	3-1
3.3	Grinding Wheel Shaft Bearings.....	3-1
SECTION 4	MAINTENANCE & TROUBLESHOOTING	4-1
4.1	Sharpener Maintenance	4-1
4.2	Blade Sharpening Tips	4-2
SECTION 5	ALIGNMENT	5-1
5.1	Saw Head Stop Adjustment.....	5-1

Table of Contents

Section-Page

SECTION 6 BLADE HANDLING

6-1

6.1	Coiling The Blade.....	6-1
6.2	Uncoiling The Blade.....	6-3
6.3	Inverting The Blade.....	6-5
6.4	Storing Blades.....	6-7

SECTION 7 REPLACEMENT PARTS

7-1

7.1	How to use the Parts List.....	7-1
7.2	Sample Assembly.....	7-1
7.3	Stand Assembly.....	7-2
7.4	Cover Assembly.....	7-4
7.5	Blade Support Assembly.....	7-6
7.6	Additional Blade Support Assembly (Option).....	7-7
7.7	Electric Box.....	7-8
7.8	Control Panel.....	7-9
7.9	Coolant Tank.....	7-10
7.10	Mounting Plate.....	7-11
7.11	Sharpener Head.....	7-12
7.12	Cam & Index Arm Drive Assembly.....	7-15
7.13	Sharpener Head Lever.....	7-17
7.14	Clamp and Coolant Wiper.....	7-18
7.15	Deburr Assembly.....	7-20
7.16	Magnetic Filter.....	7-22
7.17	Magnetic Filter (Sharpener BMS600).....	7-24
7.18	Alignment Tool&Blade ProfileTemplate.....	7-25
7.19	Decal Kit.....	7-26
7.20	3" Blade Supports Kit (Option).....	7-27
7.21	Table Extensions Kit (BMS600 Option).....	7-30

SECTION 1 SAFETY & GENERAL INFORMATION



This symbol calls your attention to instructions concerning your personal safety. Be sure to observe and follow these instructions. This symbol accompanies a signal word. The word **DANGER** indicates an imminently hazardous situation which, if not avoided, will result in death or serious injury. **WARNING** suggests a potentially hazardous situation which, if not avoided, could result in death or serious injury. **CAUTION** refers to potentially hazardous situations which, if not avoided, may result in minor or moderate injury to persons or equipment. Read all safety instructions before operating this equipment and observe all safety warnings!



Warning stripes are placed on areas where a single decal would be insufficient. To avoid serious injury, keep out of the path of any equipment marked with warning stripes.

Read and observe all safety instructions before operating the sharpener! Also read any additional manufacturer's manuals and observe any applicable safety instructions including dangers, warnings, and cautions.

Always be sure that all safety decals are clean and readable. Replace all damaged safety decals to prevent personal injury or damage to the equipment. Contact your local distributor, or call your Customer Service Representative to order more decals.

Always properly dispose of all by-products, including debris, coolant and oil.

Safety instructions are listed in this section by the following operations:

- Electrical Safety
- Blade Handling
- Machine Operation

1.1 Electrical Safety



DANGER! Make sure all electrical installation, service and/or maintenance work is performed by a qualified electrician and is in accordance with applicable electrical codes.

DANGER! HAZARDOUS VOLTAGE can cause shock, burns, or death. SHUT OFF & LOCK OUT POWER before performing service in any area of this machine. DO NOT restore power until all access panels are replaced and secured.



WARNING! Before performing any service to the machine, always turn off power supply using the disconnect switch on the electrical box and remove the plug from the power socket.

1.2 Blade Handling



WARNING! Always wear gloves and eye protection when handling bandsaw blades. Keep all persons away from area when coiling or carrying a blade (4 meters at least).

1.3 Machine Operation



DANGER! Make sure all guards and covers are in place and secured before operating the sharpener. Failure to do so may result in serious injury.

DANGER! Keep all persons at a safe distance from moving parts when operating this machine. Failure to do so may result in serious injury.

DANGER! Always keep hands away from moving bandsaw blade. Failure to do so will result in serious injury.



WARNING! Always wear eye, ear, respiration, and foot protection when operating this machine. Failure to do so may result in serious injury.

WARNING! Secure all loose clothing and jewelry before operating this machine. Failure to do so may result in serious injury or death.

WARNING! The sharpener should not be operated by persons allergic to ACP-1 oil or its vapors.

1.4 Sharpener Components

See **Figure 1-1**. The major components of the BMS500/BMS600 Industrial Sharpener are shown below.

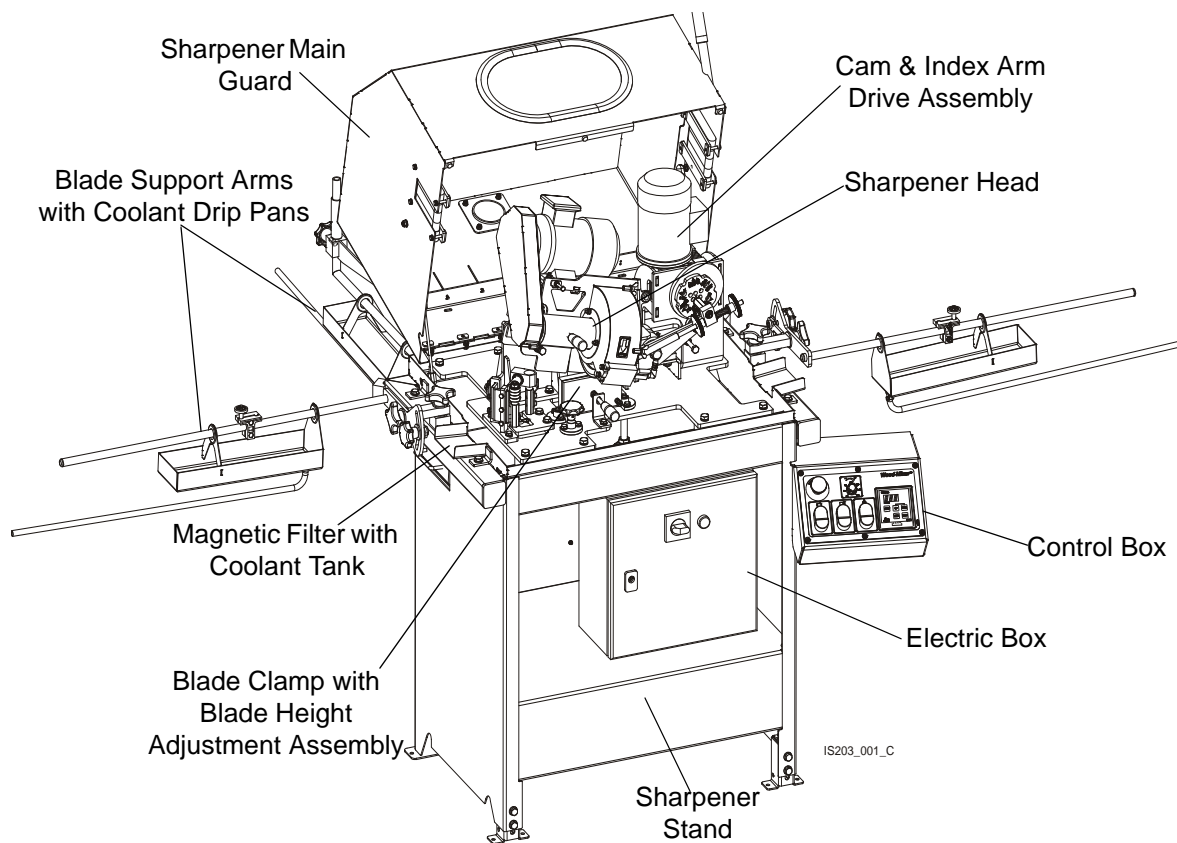

FIG. 1-1

1.5 Overall Dimensions

See Table 1-1. The overall dimensions of the BMS500/BMS600 sharpener (without the blade support arms) are listed below.

Model	Length	Width	Height
BMS500/BMS600	865mm (34")	1202mm (47.32")	1476mm (58.11")

TABLE 1-1

See Figure 1-2. The figure below shows overall dimensions of the BMS500/BMS600 sharpener with the blade support arms installed.

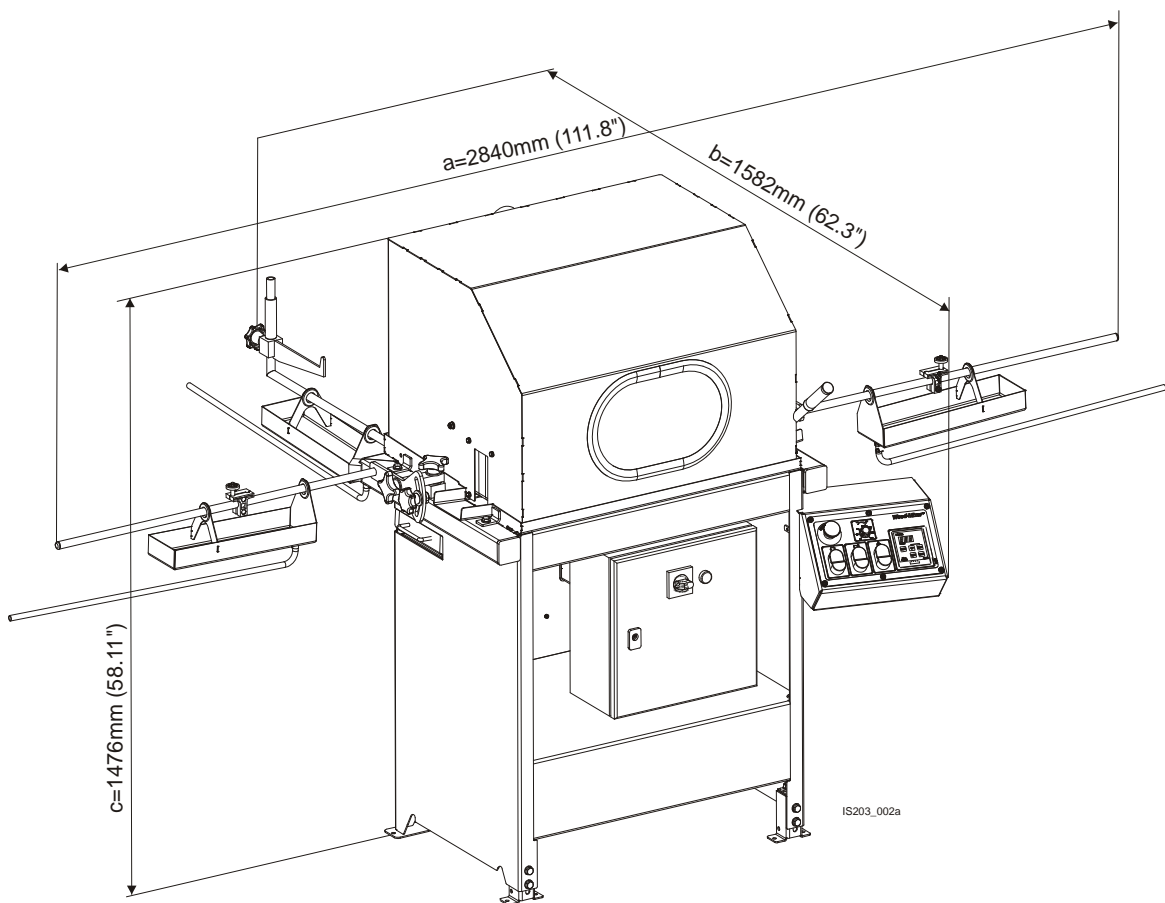

FIG. 1-2

1.6 Noise Level

See Table 1-2. The level of noise generated by the BMS500/BMS600 sharpener is given in the table below¹.

	Max. Noise Level
BMS500/BMS600	80 dB (A)

TABLE 1-2

1.7 Motor Specifications

See Table 1-3. The grinder motor specifications are listed below.

Type	Manufacturer	Model	Power	Other Data
Electric Motor	Besel, Poland	Sh7IX-2C	.75 kW	2820 r.p.m.

TABLE 1-3

See Table 1-4. See the table below for the supply voltage specifications.

Sharpener Type	Voltage	Current/Frequency
BMS500AU BMS600AU	1 x 230V [L1+N (L1=230V, N-neutral)] 1 x 230V [L1+L2 (230V phase-to-phase voltage)]	18A @ 50/60Hz 22A @ 50/60Hz
BMS500B(S/U) BMS600B(S/U)	3 x 230V	12A @ 50/60Hz 16A @ 50/60Hz
BMS500C(S/U) BMS600C(S/U)	3 x 460V	5,5A @ 50/60Hz 8,5A @ 50/60Hz
BMS500H(S/U) BMS600H(S/U)	3 x 400V	10,5A @ 50/60Hz 11,5A @ 50/60Hz

TABLE 1-1

1. The measured values refer to emission levels, not necessarily to noise levels in the workplace. Although there is a relation between emission levels and exposure levels, it is not possible to determine with certainty if preventives are needed or are not needed. The factors affecting a current level of noise exposure during work are inter alia room characteristics and characteristics of other noise sources, e.g. number of machines and machining operations nearby. Also, the permissible exposure level value may vary depending on country. This information enables the machine's user to better identify hazards and a risk.

1.8 Technical Data

See Table 1-5. See the table below for technical data on the BMS500/BMS600 sharpener.

Maximum Blade Width	76 mm (3")
Grinding Wheel Main Shaft Speed	4280 rpm
Feed Rate	0-64 teeth / min
Coolant Tank Capacity	10 l (2.64 gallon)
Cam Motor Power	.25 kW
Total Power	1.2 kW
Sharpener Weight	270 kg (595 lb)

TABLE 1-5

See Table 1-6. See the table below for coolant specifications.

Oil Type	Manufacturer	Freezing Point	Flash Point	Autoignition Point	Viscosity
ACP-1E ¹	Orlen ²	-20° C (-4° F)	Above 140° C (284° F)	250° C (482° F)	18-20 cST (1,8-2*10 ⁻⁵ m ² /s) at 40°C (5.905 ft/s at 104° F)

TABLE 1-6

¹ Waste oil must be disposed of in compliance with applicable national and local regulations.

² You may use oil of different manufacturer, but it must meet specification shown above.

1.9 Control Panel Components

See Figure 1-3. The control panel components and their descriptions are given below.

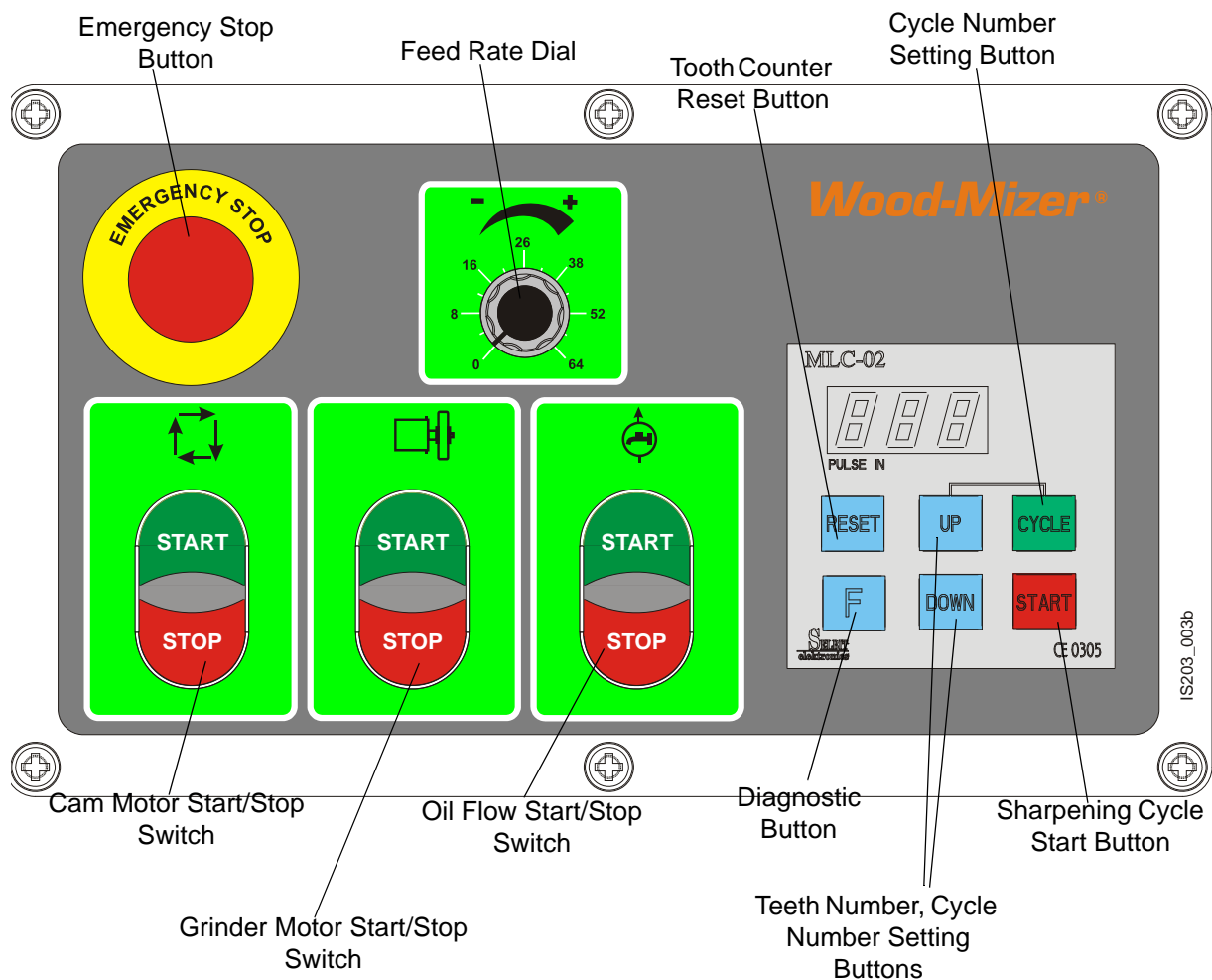

FIG. 1-3

- **Emergency Stop Button**
Shuts off all sharpener operations.

Press this button to shut off all machine operations. **NOTE:** After being activated, the emergency stop button must be reset before the sharpener can be operated again. To reset, rotate the button counterclockwise and release.

- **Feed Rate Dial**
Controls cam rotational speed, i.e. number of sharpened teeth per minute.

Rotate the dial as necessary to increase or decrease the cam speed.

- **Cam Motor Start/Stop Switch**

Press "START" on the Cam Motor Start/Stop Switch to start the cam and index arm motor.

NOTE: Before starting the cam motor, place the Feed Rate Dial in the "0" position.

To turn off the cam motor and unclamp the blade, press "STOP" on the Cam Motor Start/Stop Switch.

- **Grinder Motor Start/Stop Switch**
Starts/stops the grinder motor.
- **Oil Flow Start/Stop Switch**
Starts/stops the coolant pump motor.
- **Tooth Counter**
Sets/keeps track of number of teeth to be sharpened and sharpening cycles.

The display shows a preset number of blade teeth to be sharpened. To set this number, use the "UP" and "DOWN" buttons located under the display window. When sharpening cycle is started (with the Sharpening Cycle Start Button), the display will be showing current number of teeth that have been sharpened. After reaching the set number of teeth, "End" will be displayed and the tooth counter has to be reset before the sharpener can be operated again. To reset, press the "RESET" button. If you need to sharpen the blade more than once, before starting set the cycles number using the "CYCLE" button (for ex. if you want to set three cycles, press "CYCLE" button three times). The diagnostic button "F" is used to check the outputs of the counter. Press and hold the "F" button to start the diagnostic process. When it is finished, the counter will go back to normal operation.

- **Disconnect Switch (located on the main electric box)**
Disconnects/connects power to the machine.

Turn the switch to the horizontal position ("0" - OFF) to lock out all electrical power during service or when the sharpener is not in use. **NOTE:** Place the disconnect switch in the "0" position before opening the electric box door.

To reconnect power to the machine, turn the switch to the vertical position ("1" - ON).

1 Safety & General Information

Control Panel Components

See Figure 1-4. The disconnect switch on the sharpener electric box is shown below.

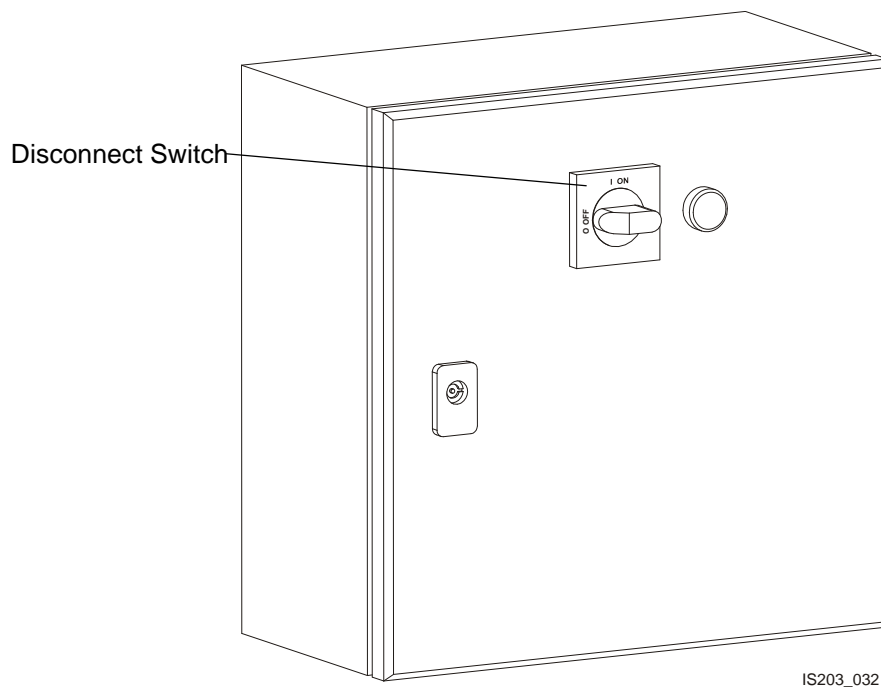

FIG. 1-4

1.10 Safety Decals Description

See Table 1-7. See the table below for descriptions of the pictographic warning and informative decals placed on the BMS500/BMS600 sharpener.

TABLE 1-7









Decal View	Decal No.	Description
	S10364-P2	"Hazardous voltage"
	086362	General warning symbol
	096317	CAUTION! Read thoroughly the manual before operating the machine. Observe all safety instructions and rules when operating the sharpener.

TABLE 1-7

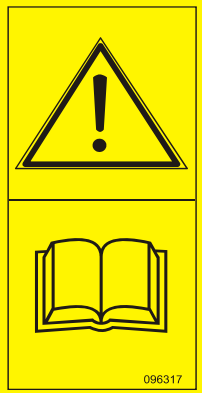
	<p>099220</p>	<p>Close all guards and covers before starting the machine.</p>
	<p>095961</p>	<p>Use ACP-1 oil.</p>
	<p>S12004G-1</p>	<p>Always wear safety goggles when operating the sharpener!</p>
	<p>S20097K</p>	<p>Direction of motor revolutions - 4280 r.p.m.</p>
	<p>P85070</p>	<p>CE safety certification</p>

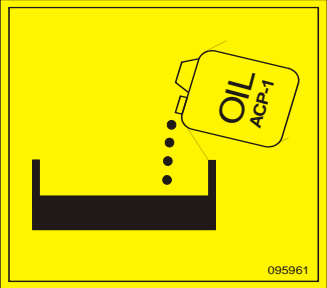
SECTION 2 SETUP & OPERATION

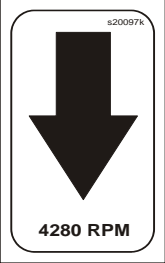
2.1 Starting the Machine



IMPORTANT! Before starting to use the sharpener, perform the following steps:

- Remove the machine from the pallet.

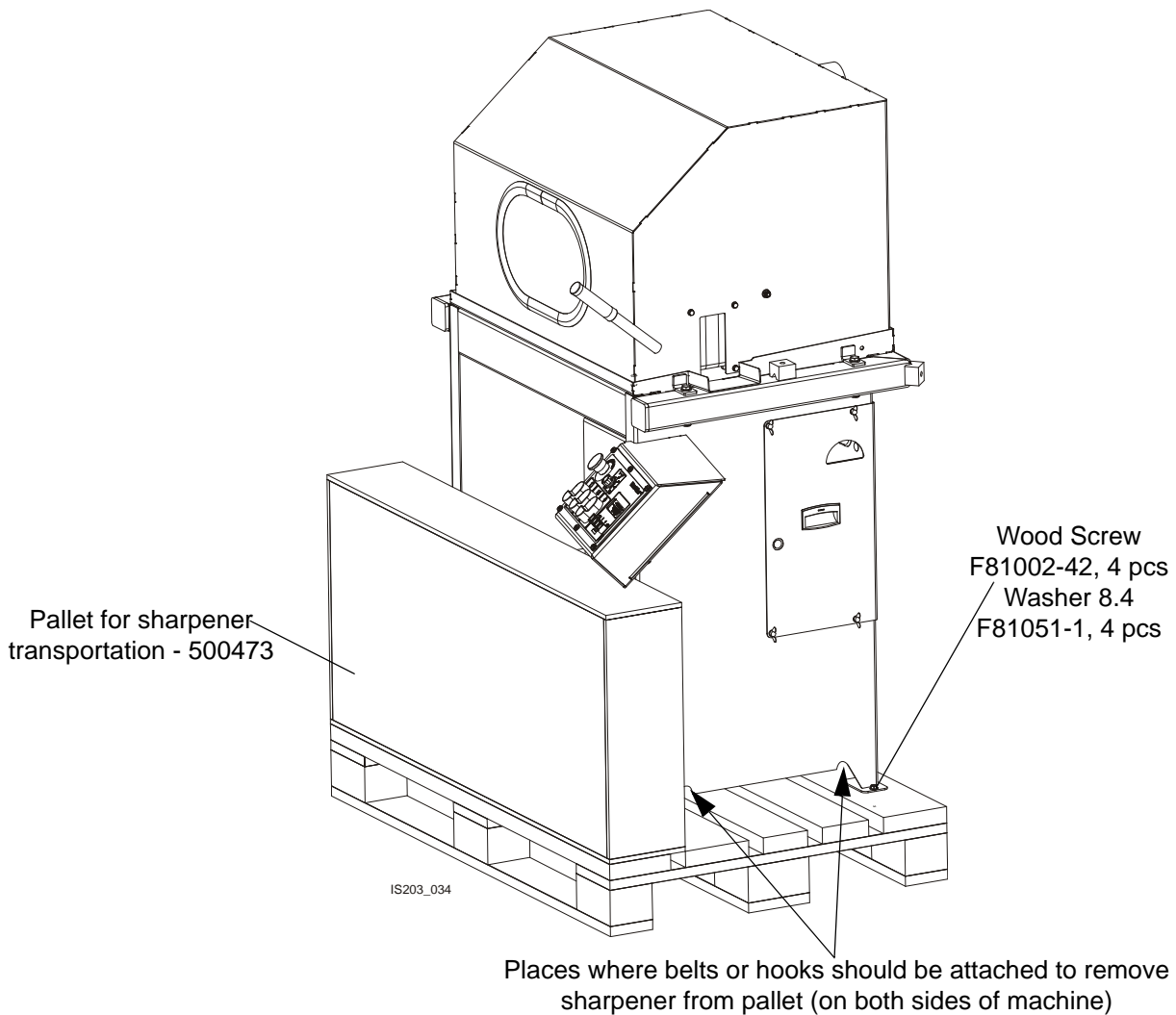

- Fasten the sharpener to the floor using the mounting holes in the feet.
- The sharpener can be operated with an oil mist exhaust system only.
- The machine can be operated under roof only.
- The machine can be operated at the temperature range of 5° C to 40° C (41°F to 104°F) and at the humidity of up to 80 percent.

2 SETUP & OPERATION

Starting the Machine

- For cooling the grinding wheel, use only oil meeting the specifications: [See Table 1-2](#). Do not use any other liquids, e.g. water.
- The position of the sharpener operator is shown below.

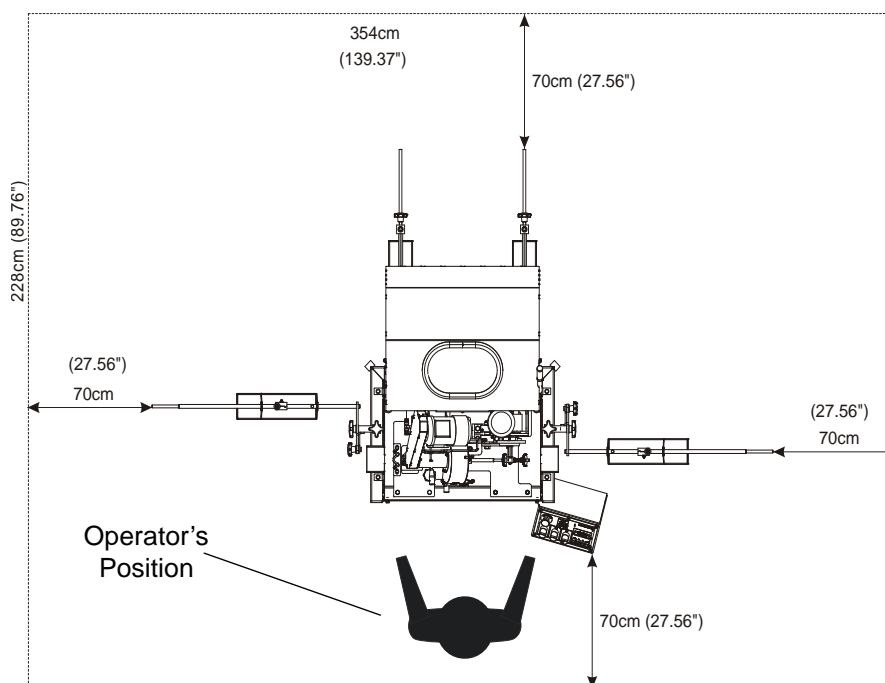

- The operator must always wear safety goggles and protective gloves when operating the sharpener.
- There must be at least 70cm (27.56") of free space around the sharpener.
- Have a qualified electrician install the power supply. The power supply should meet the specifications given in the table below.

Sharpener Type	Voltage	Fuse Disconnect [A]	Recommended Wire Size
BMS500AU BMS600AU	230V [L1+N (L1=230V, N-neutral)] 230V [L1+L2 (230V phase-to-phase voltage)]	10 Amp	minimum 1.5 mm ² (min. 15 AWG)
BMS500B(S/U) BMS600B(S/U)	3 x 230V	10 Amp	minimum 1.5 mm ² (min. 15 AWG)
BMS500C(S/U) BMS600C(S/U)	3 x 460V	10 Amp	minimum 1.5 mm ² (min. 15 AWG)
BMS500H(S/U) BMS600H(S/U)	3 x 400V	10 Amp	minimum 1.5 mm ² (min. 15 AWG)

TABLE 2-1



DANGER! It is recommended that a 30mA GFI (Ground Fault Interrupter) be used.

2.2 Blade Support Arms Installation

The industrial sharpener is equipped with two side blade support arms with guide assemblies.

To install the support arms, first apply grease to their threaded ends. Then insert the arms into the threaded holes on both sides of the sharpener.

1. Each guide assembly includes a blade support with post, a blade support without post, two bolts, a locking nut and a wing nut.

See Figure 2-1. To install the guide assemblies, join each of them around one blade support arm. Face the post outward as shown. Connect the both parts of the assembly using the provided hex head bolts. Bolt from the hexed side of the guide assembly (these hex-shaped holes will keep the bolts from turning once in place). Secure the bottom bolt with a locking nut. Secure the top bolt with a wing nut.

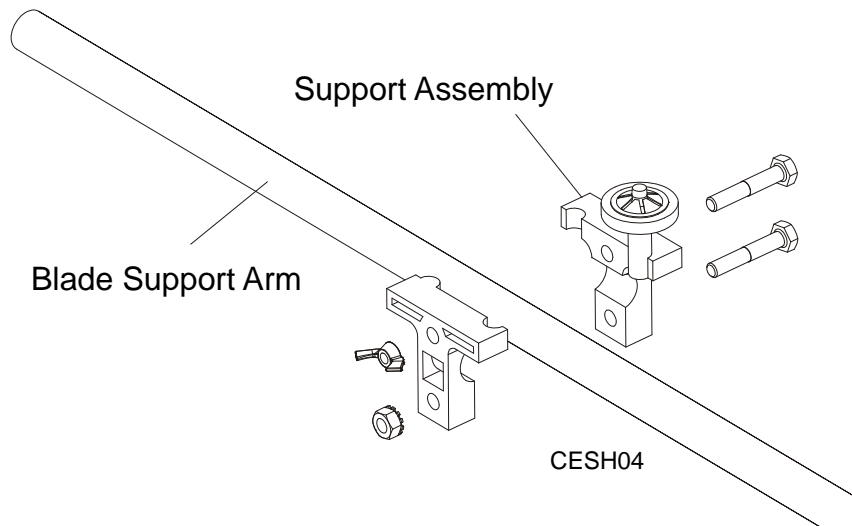

2. Tilt the guides on the left blade support arm slightly backward, toward the rear of the sharpener. Tilt the guides on the right support arm slightly forward, toward the front of the sharpener.
3. The guide assembly can be positioned at any location on the blade guide arm, depending on the blade length. The side blade support arms can be adjusted horizontally if necessary. All blade

2 SETUP & OPERATION

Blade Height Adjustment

support arms can be adjusted up or down, depending on the blade width.

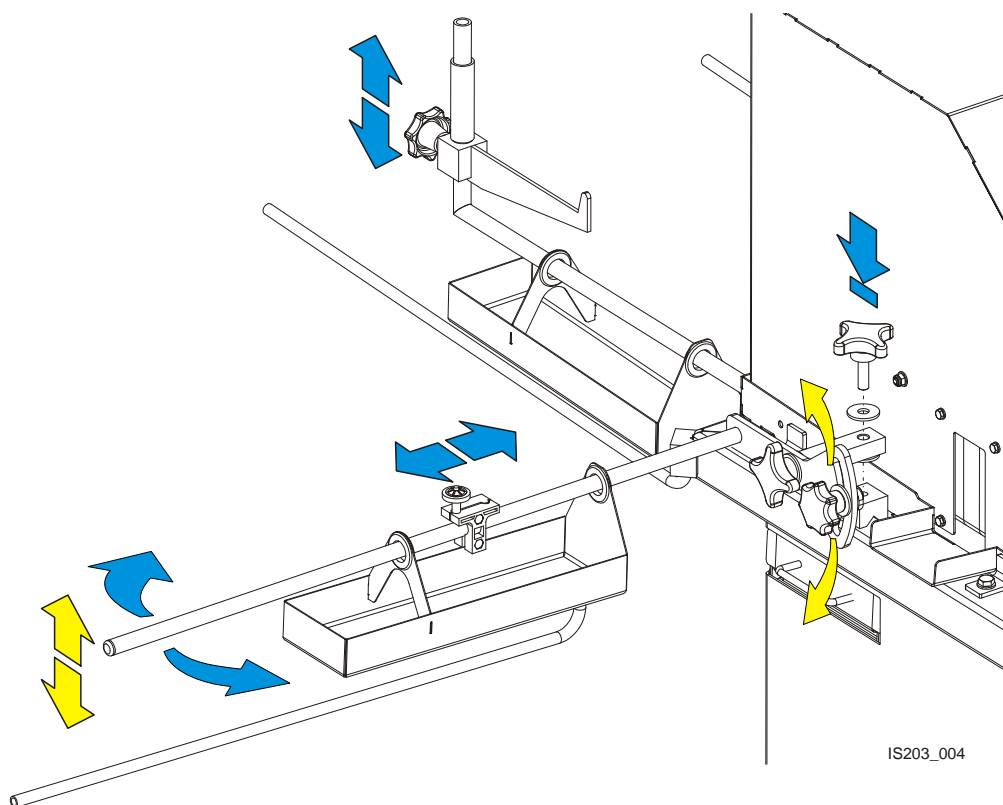

2.3 Blade Height Adjustment

The BMS500/BMS600 sharpener is equipped with a blade height adjustment assembly that allows smooth height adjustment of 1" (25 mm), 1 1/4" (31.25 mm), 1 1/2" (37.5 mm), 1 3/4" (43.75 mm), 2" (50mm) and 3" (75mm) wide blades.

To install the blade, release the blade clamp by pushing the clamp handle down.

See Figure 2-2. Position the blade on the cylindrical rollers of the blade height adjustment screws as

shown below. Use the blade height adjustment knob to adjust the blade height.

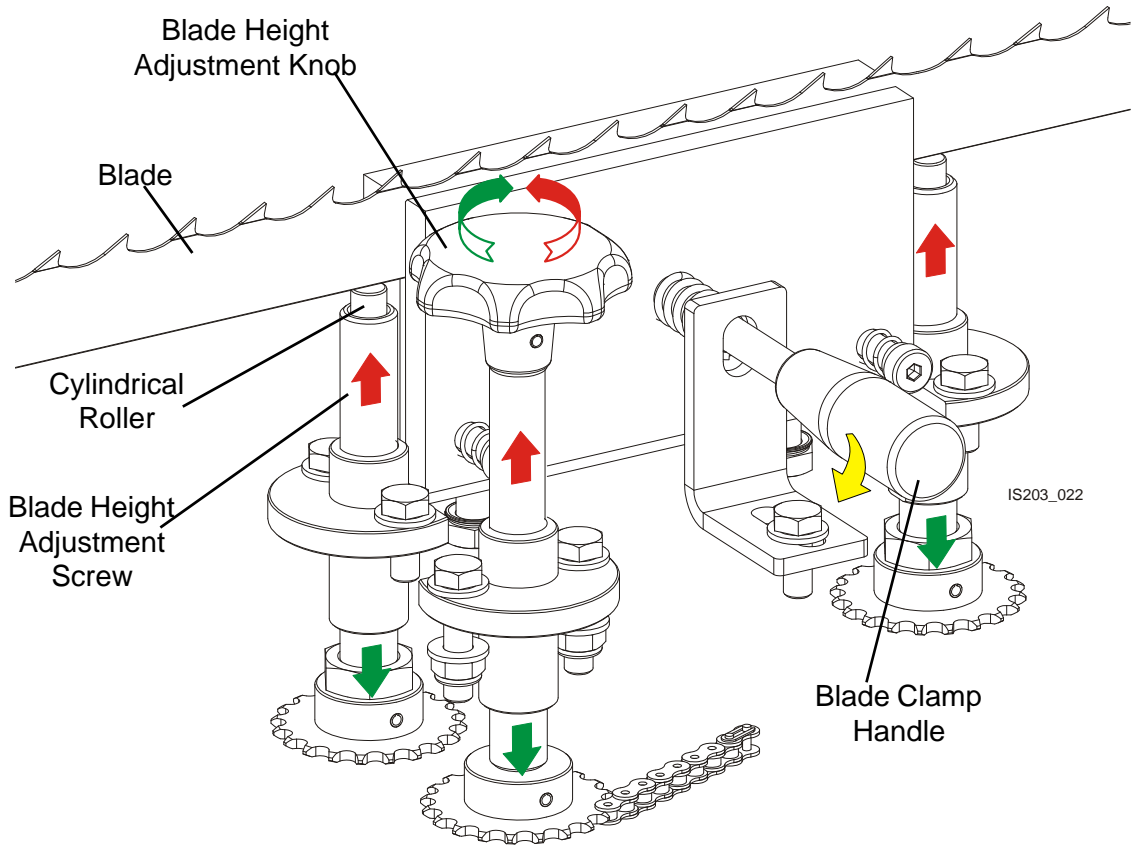

FIG. 2-1



IMPORTANT! After adjusting the blade height, adjust the blade support arms in the vertical plane as necessary so the blade will remain level around its complete length.

2.4 Sharpener Alignment

Use the provided alignment tool as necessary to achieve accurate alignment between the blade clamp and the grinding wheel.



IMPORTANT! Do not attempt to adjust the set screws of the tool. They have been adjusted at the factory to ensure accurate alignment results.



CAUTION! Make sure the grinder motor is OFF.

1. Cycle the cam until the grinding wheel is at the tip of the tooth (about to begin face grind).
2. Remove the grinding wheel side guard and the grinding wheel mounting nut. Dismount the oiler. Remove the grinding wheel.
3. Remove the moving blade clamp plate.
4. Install the alignment tool to the spindle main shaft (Nr WM#505190) as shown below.

See **Figure 2-3**. Position the tool so that all three set screws touch the fixed blade clamp plate. Reinstall the grinding wheel mounting nut and tighten to secure in place.

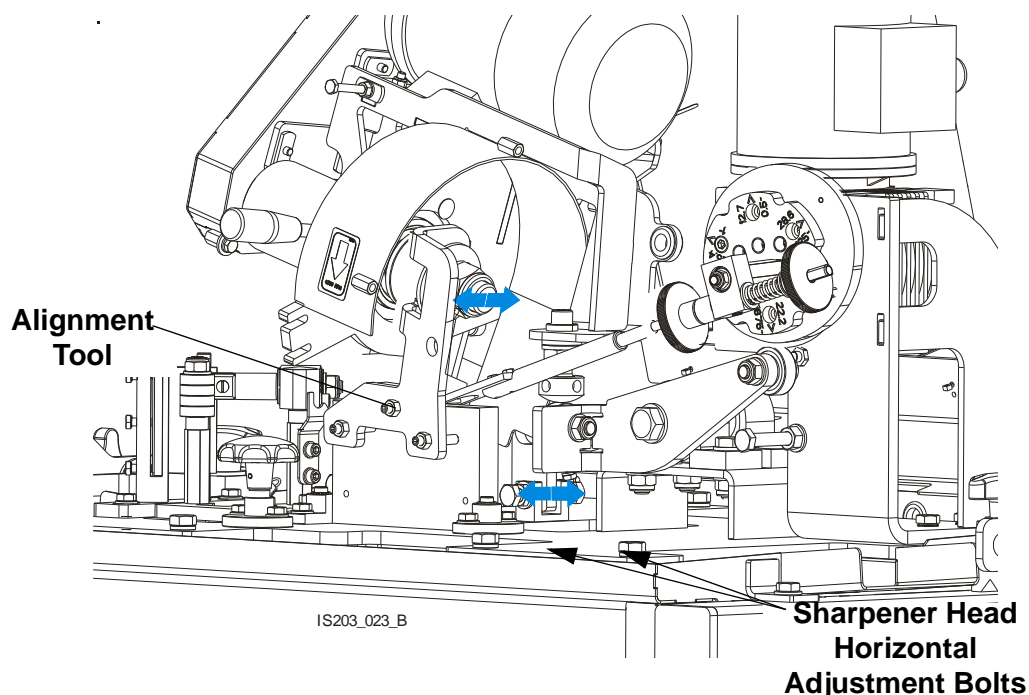

FIG. 2-1

5. If any of the tool set screws does not touch the fixed clamp plate, loosen the sharpener head mounting bolts shown in the figure below.

- Using the adjustment bolts, adjust the sharpener head in the horizontal plane so that all three alignment tool set screws touch the fixed clamp plate. Secure in position by tightening the sharpener head mounting bolts.

See Figure 2-4.

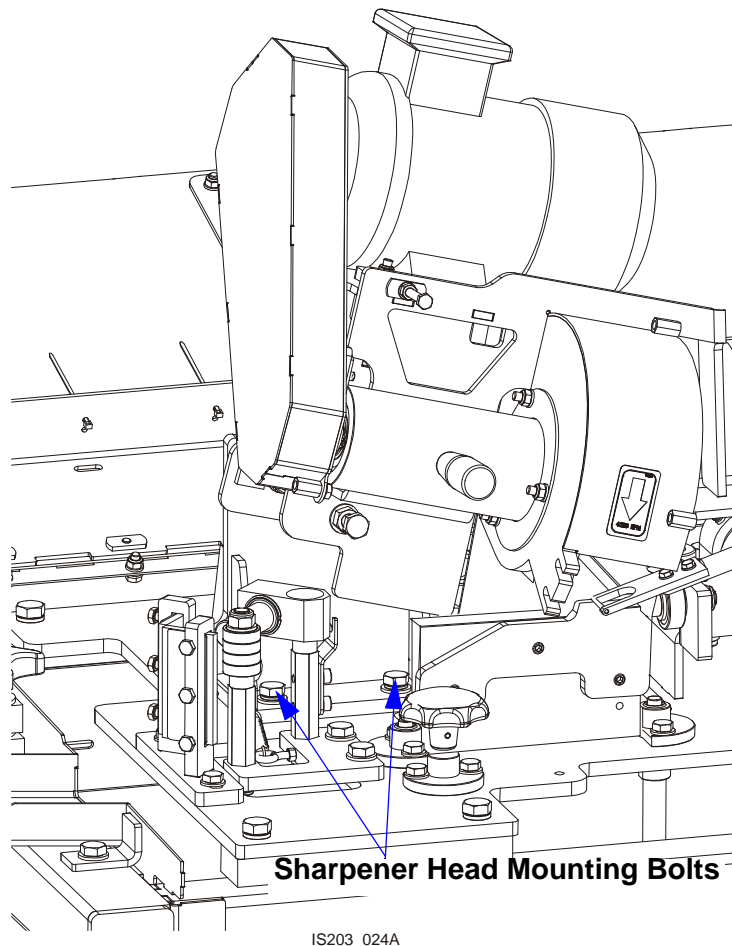

FIG. 2-2

- Remove the grinding wheel mounting nut and the alignment tool.
- Install the moving blade clamp plate.
- Install the grinding wheel and secure in place with the mounting nut.
- Mount the oiler. Install the grinding wheel side guard.

2.5 Drive Belt Tension

The drive belt should be tightened to 0.33" (8.5 mm) deflection with 4.5 pounds (20N) of deflection force.

See Figure 2-5.

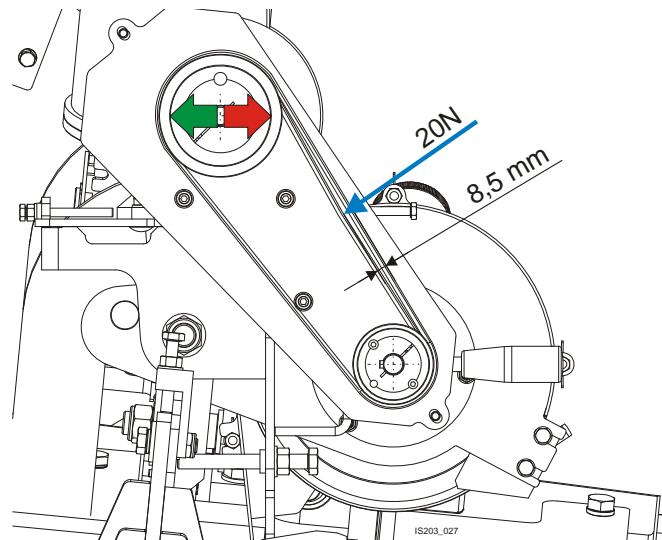

FIG. 2-1

See Figure 2-6. Loosen the nuts on the grinder motor mounting bolts. Turn the lower tensioning bolt clockwise and the upper tensioning bolt counterclockwise to tighten the drive belt. Turn the upper tensioning bolt clockwise and the lower tensioning bolt counterclockwise to loosen the drive belt.

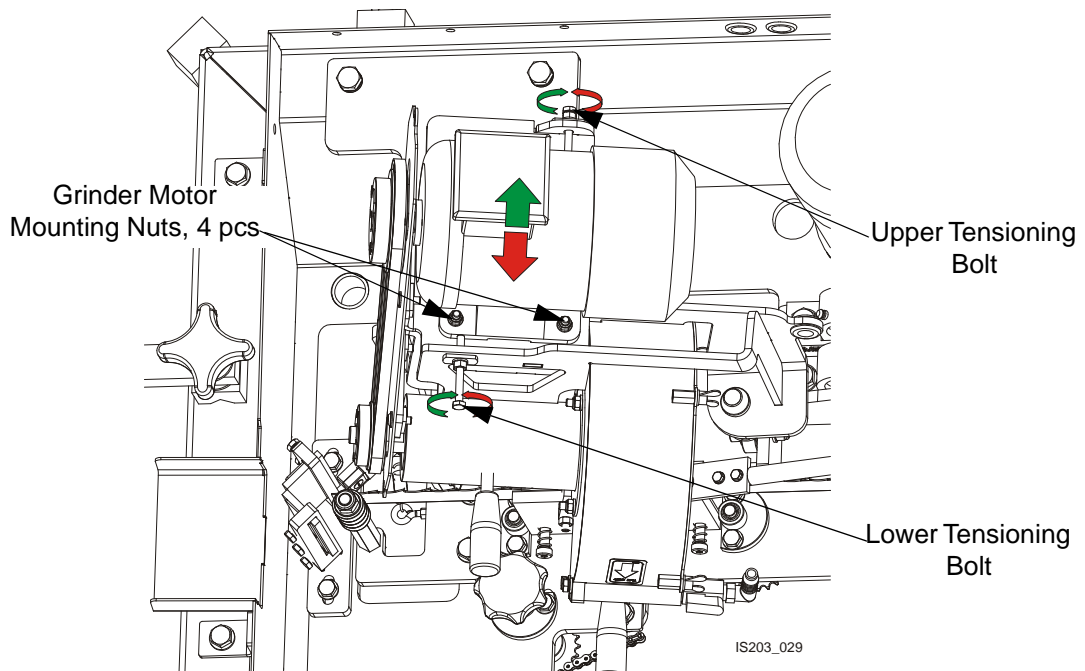



FIG. 2-2

2.6 Grinding Wheel Installation

Use a Wood-Mizer approved grinding wheel. To install the grinding wheel, perform the following steps:

1. Push the START button  on the control box and turn the feed rate dial clockwise to rotate the cam.
2. Rotate the cam until the sharpener head is raised all the way up. Turn the feed rate dial all the way down and push the STOP button .
3. Remove the grinding wheel side guard.
4. Dismount the oiler.
5. Remove the nut and the grinding wheel clamping plate from the spindle shaft.
6. Slide a grinding wheel onto the spindle shaft.
7. Install the grinding wheel clamping plate.
8. Tighten the nut to 44.2 ft-lbs (60Nm) torque.
9. Mount the oiler.
10. Install the grinding wheel side guard.



DANGER! Make sure all guards and covers are in place and secured before operating the sharpener. Failure to do so may result in serious injury.

2.7 Blade Installation

1. Uncoil a blade and position it on the inside of the rear support arms and on the outside of the guide posts located on the side support arms.
2. Place the blade between the blade wiper plates and the blade clamp plates.
3. Make any final adjustments to the support arms and guide assemblies to ensure the blade band rests evenly on both, the right and left blade clamp cylindrical rollers. Make sure the blade does not touch the bottom of either side guide assembly.

Make sure the guide assemblies lean slightly in the direction the blade travels through them.

4. Rotate the pivot arm of the deburr assembly so that the carbide cutting plate touches the blade.

2.8 Face Grind Adjustment

As you operate the sharpener, the cam will rotate causing the index arm to contact a tooth and push it to a position under the grinding wheel. The index arm can be adjusted to leave the tooth closer to or further from the grinding wheel so the tooth face is ground lighter or heavier.

1. Before adjusting the face grind, make sure the cam and grinder motors are off and the feed rate dial is set at "0".
2. Manually raise the sharpener head.
3. Turn on the cam motor. Slowly increase the FEED RATE until the next tooth is underneath the grinding wheel.
4. Lower the sharpener head and make sure the grinding wheel lightly contacts the entire face of the tooth all the way up to the tip.
5. Turn on the grinder motor.

See Figure 2-7. If the face grind is too light, turn the face grind adjustment knob out, away from the other knob. If the face grind is too heavy, turn the adjustment knob in, toward the other knob.

6. Check the face grind on the next tooth and adjust as needed.

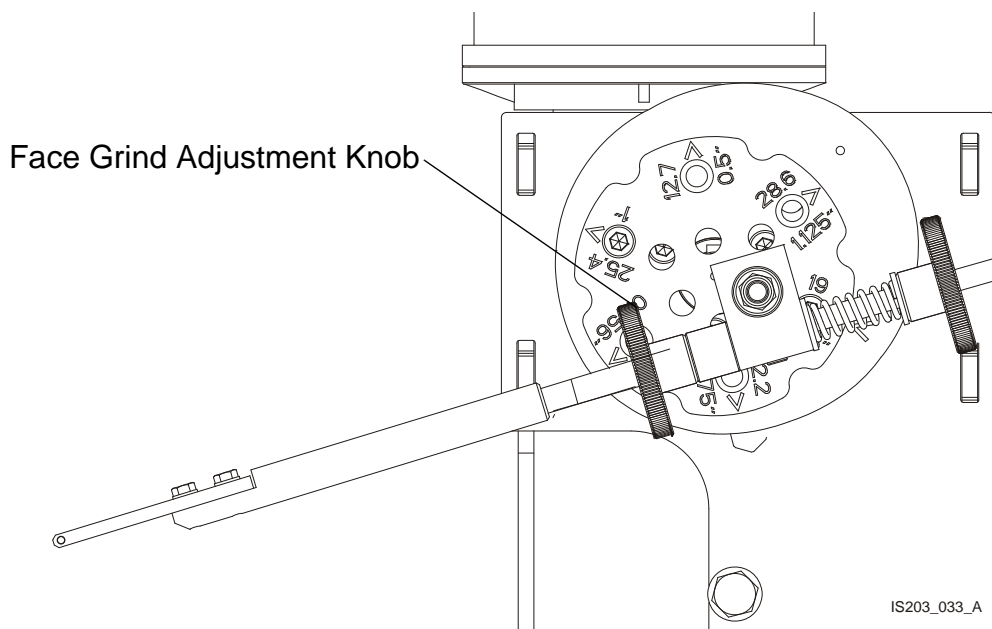

FIG. 2-1

The figure below shows proper position of the grinding wheel in relation to the blade being sharpened.

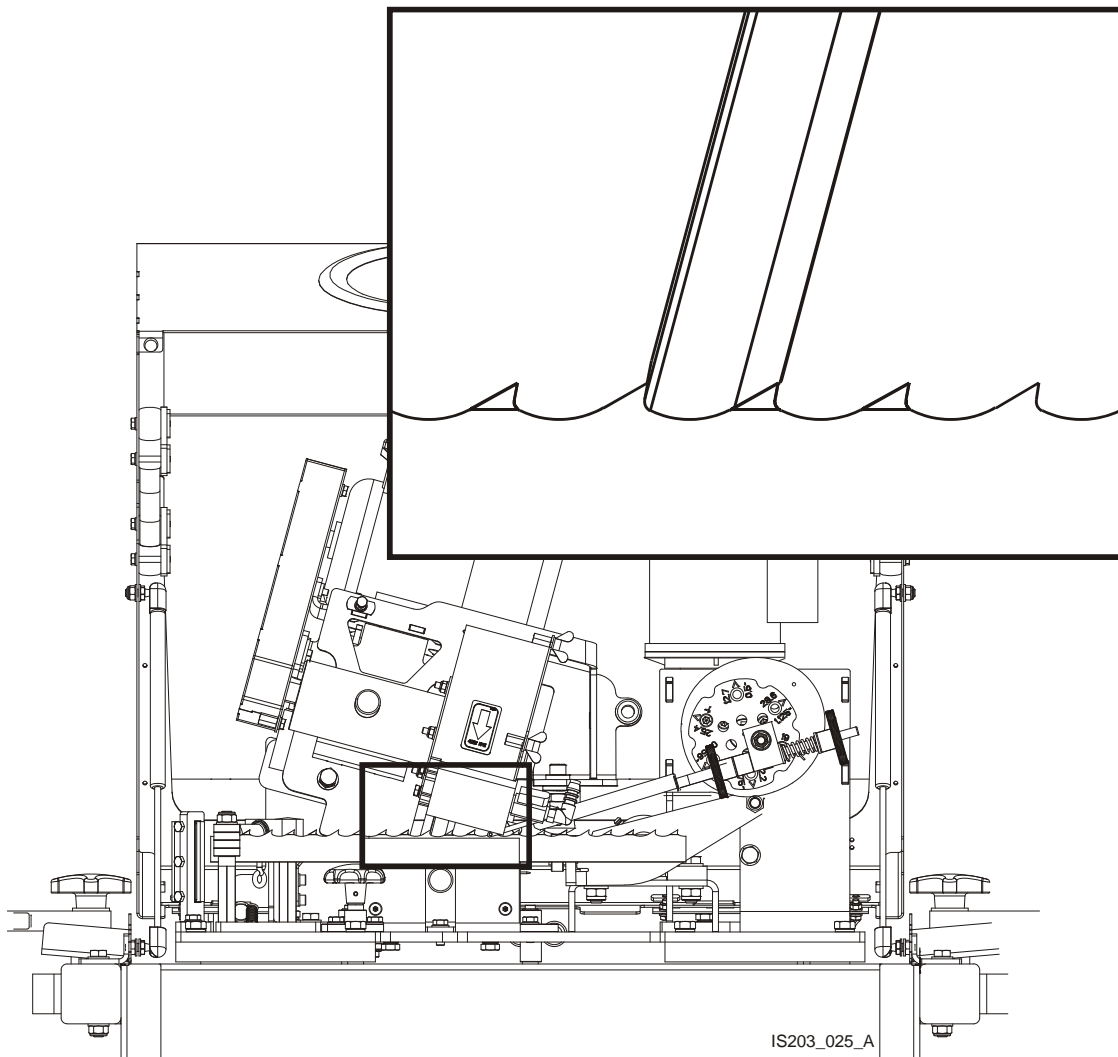

FIG. 2-2

2.9 Grind Depth Adjustment

Tooth height is determined by how much material is removed from the gullet of the blade. The sharpener head is factory-set so that the grinding wheel is at the height of **2.0 to 3.0 mm (0.079" - 0.12")** above the blade clamp. To adjust the gullet grind depth, use the blade height adjustment knob shown below.

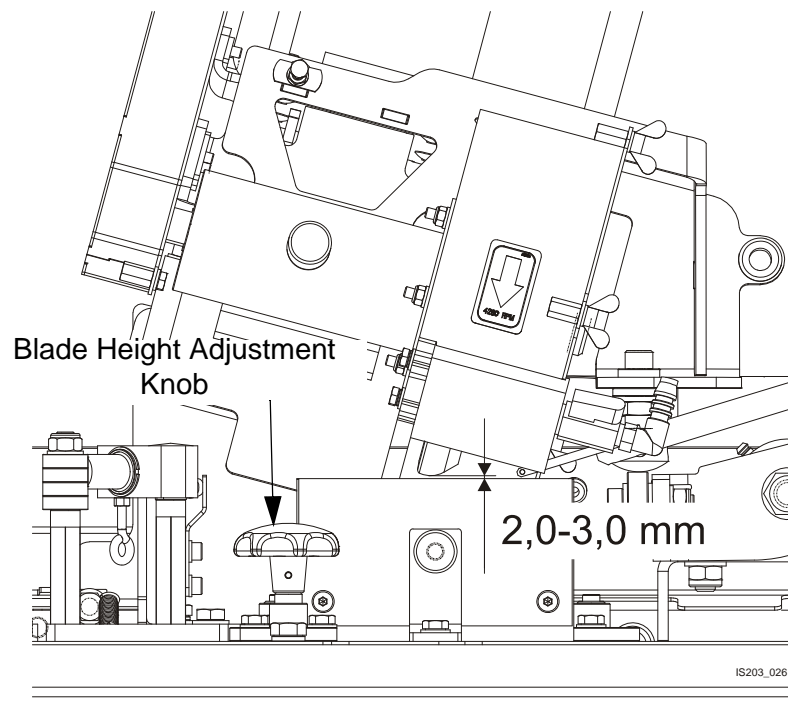

FIG. 2-1

During sharpening, inspect the gullet depth two or three times. You should see clean metal across the entire gullet of the sharpened tooth. If you do not see clean metal, stop the sharpener operation and adjust the grind depth as necessary.

IMPORTANT! After any adjustment, always restart the blade and sharpen in its entirety to ensure symmetry.

NOTE: The grind depth may be affected as the grinding wheel passes through a blade weld.

2.10 Index Arm Stroke Adjustment

The sharpener indexer can be adjusted depending on the tooth spacing of the blade. To perform this adjustment, position appropriately the adjustment plate located on the indexer cam. Unscrew the hex socket head screws mounting the plate to the cam, unscrew the indexer shaft, rotate the cam so that a given indicator on the plate is aligned with the indicator on the cam, replace the adjustment plate mounting screws and install the indexer shaft in the hole nearest to the indicator/adjustment plate mounting screw. The index arm can be adjusted for the following tooth spacings:

Tooth Spacing
.5" / 12.7mm
.656" / 16.7mm
.75" / 19mm
.875" / 22.2mm
1" / 25.4mm
1.125" / 28.6mm

TABLE 2-1

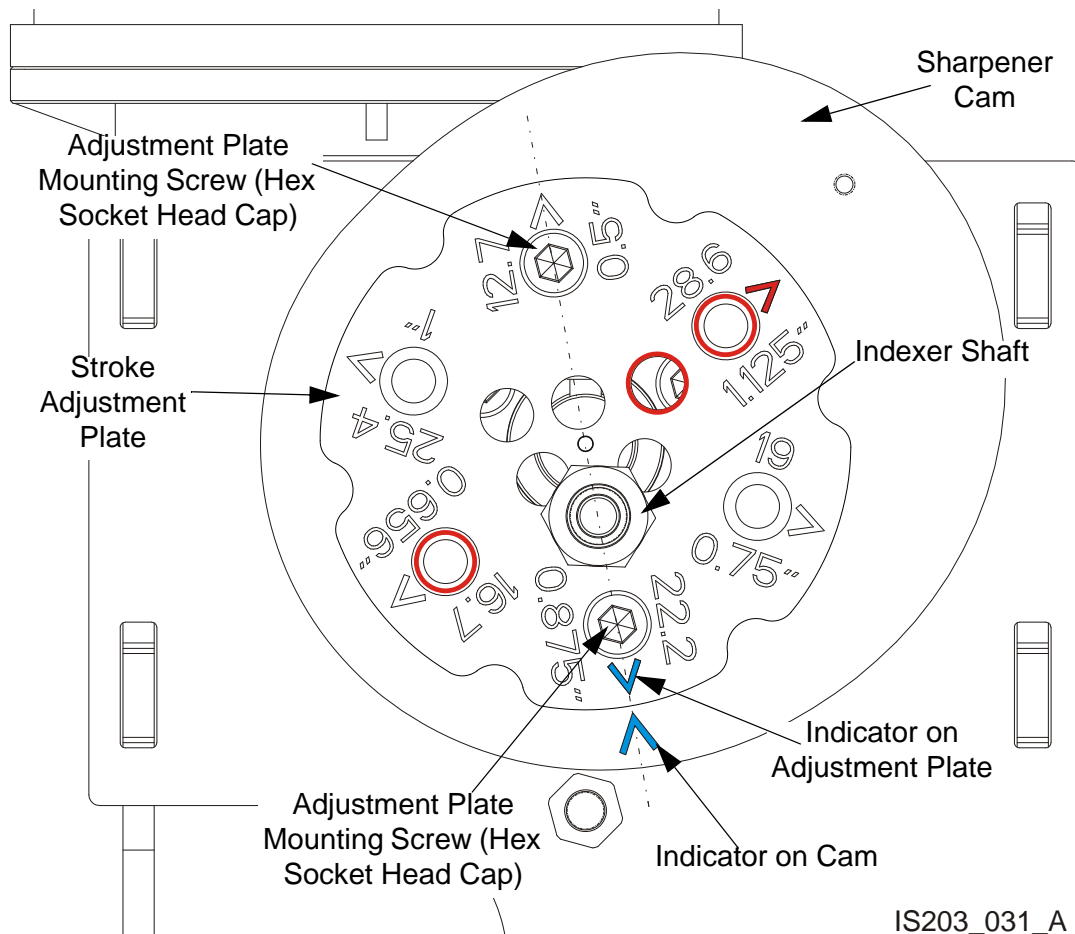

FIG. 2-2

The figure above shows proper positioning of the adjustment plate for blades with .875" (22.2 mm) tooth spacing. (The indicator on the adjustment plate is in line with the indicator on the cam.)

The exemplary indicator and holes marked with red should be used for blades with 1.125" (28.6 mm) tooth spacing.



CAUTION! The indicator located on the cam is a reference point for setting the adjustment plate on the cam depending on tooth spacing of the blade.

2.11 Oil Flow Adjustment

To start oil flow to the blade, use the Oil Flow Start/Stop Switch.

2.12 Feed Rate Adjustment

The cam speed can be adjusted with the Feed Rate Dial located on the control panel (see Figure 1-2). During the sharpening cycle, adjust the cam speed so that it is as high as possible without "burning" the blade.

NOTE: All machines should be adjusted by maintenance to a maximum speed of 40 revolutions per minute. [See Section 4.2.](#)

2.13 Blade Rejection

Sometimes blades cannot be resharpened. Reasons to reject blades for resharpening include:

- the blade is coil set (the blade is over-stressed and will fold on itself),
- the blade is missing two or more teeth in a row,
- the blade band has been twisted,
- the blade band is too low for the sharpener (the blade has been sharpened too many times/too much material has already been ground from the blade),
- the blade has no set on one of its sides,
- severe rust is present,
- the blade has tooth spacing uncommon to Wood-Mizer blades (i.e., a competitor's blade)

2.14 Sharpener Operation

Before starting the sharpening cycle, perform the following steps:

1. Adjust the blade clamp for the blade you will be sharpening.
2. Install a grinding wheel if necessary and then install a blade.
3. Using the Teeth Number Setting Buttons, set the number of teeth in the blade and number of cycles you will be sharpening.
4. Adjust face grind and gullet grind.
5. Be sure to reset the preset number of teeth (by pressing the tooth counter reset button).
6. Turn on the oil flow.
7. Increase the feed rate to a moderate speed. How fast you can grind will be determined by how much material you are removing from the blade. If a heavy grind is required, it is best to go around the blade lightly twice rather than try to grind heavily once.
8. Check the gullet grind two or three times during sharpening. Adjust as necessary.

IMPORTANT! After any adjustment, always restart the blade and sharpen in its entirety to ensure symmetry.

IMPORTANT! After adjustment always close the guard.

2.15 Shutoff

The sharpener will automatically shut off when the blade has been entirely sharpened.

Inspect the blade. Repeat the sharpening process if necessary. Blades with a bad profile or those which are badly in need of sharpening may have to be ground more than once.

2.16 3" Blade Support Setup (Option)

1. Install the 3" blade guide assembly (1) on the sharpener mount plate (2) using the washers (3,4) and the bolts shown below (5).

See Figure 2-8.

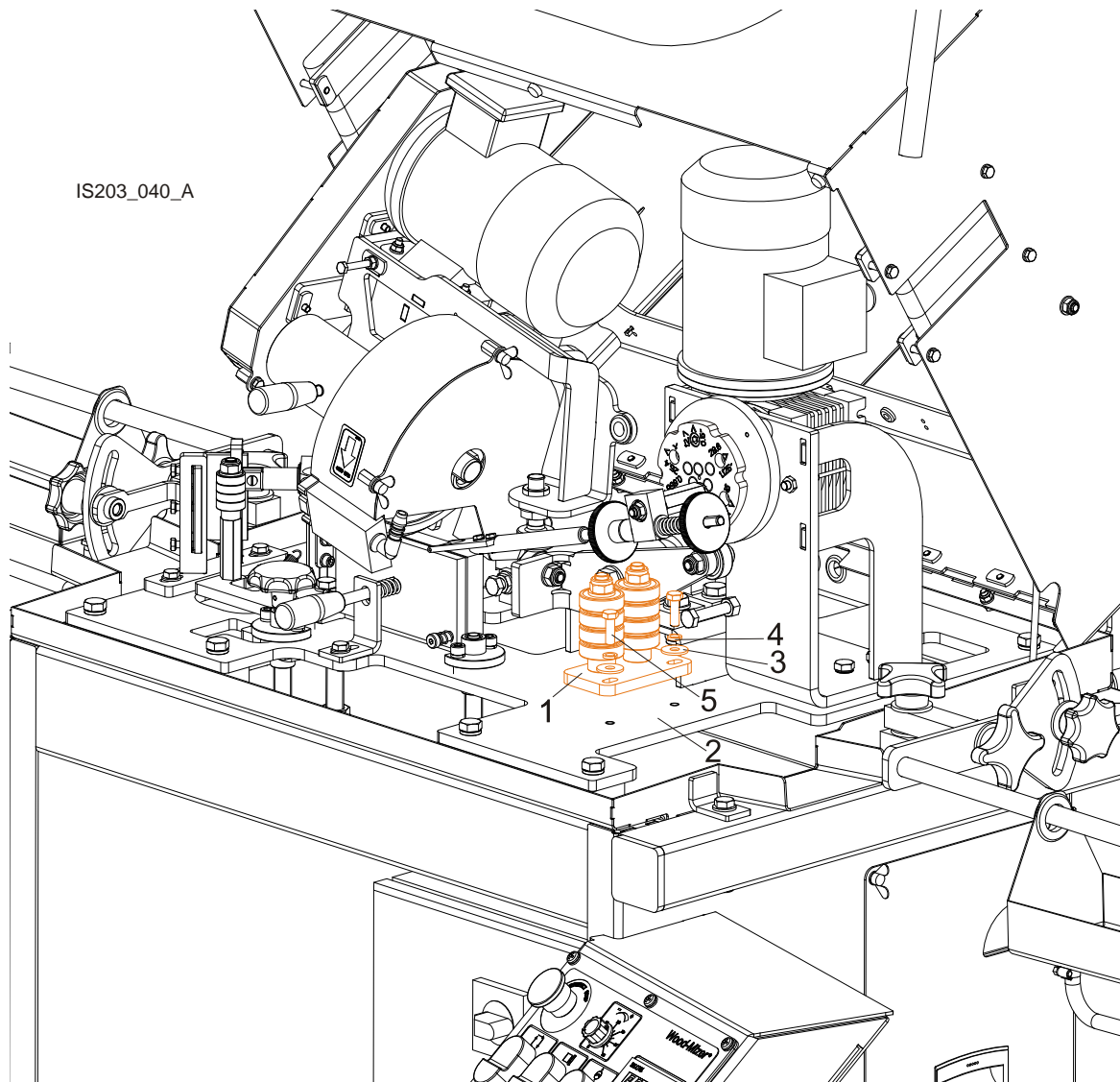

FIG. 2-1

2. Position the blade supports on the right and left side of the sharpener. Using the connector (1), connect the blade support equipped with three rollers with the sharpener.

See Figure 2-9.

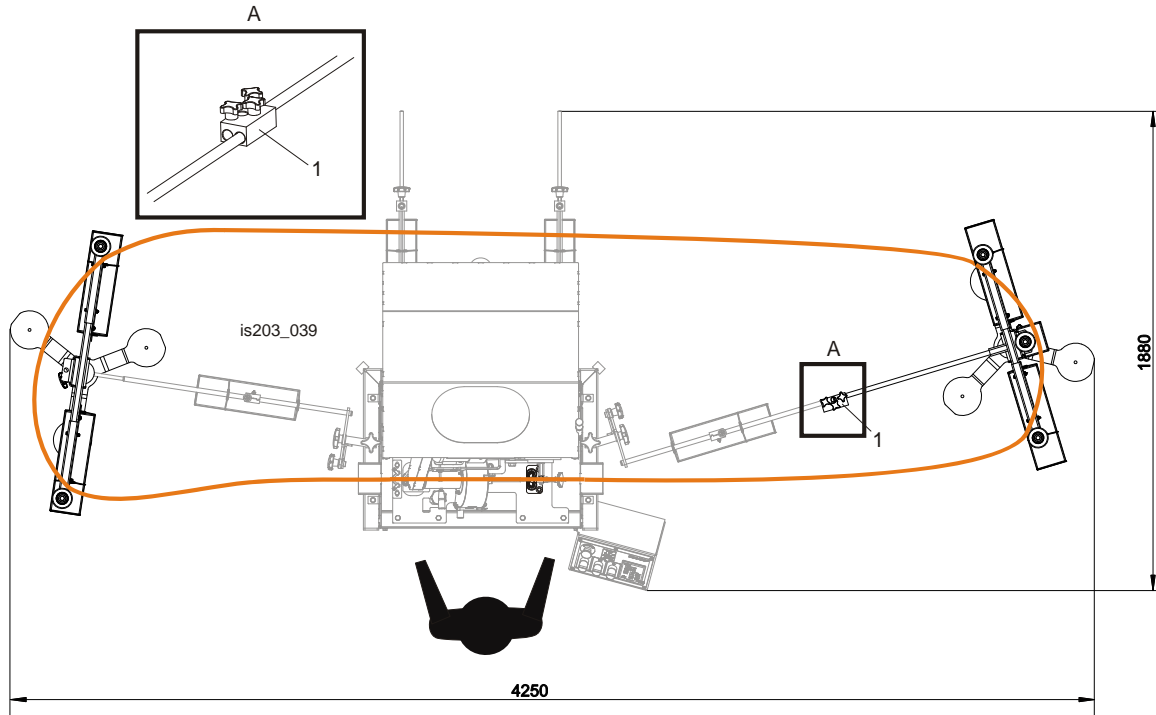

FIG. 2-2

3. Position the blade support kits so that the blade is not too loose and moves freely during the sharpening operation.
4. The blade supports should be adjusted vertically so that the bottom of the blade is at the same height along entire length of the blade.

SECTION 3 REPLACEMENT OF COMPONENTS

3.1 Grinding Wheel Replacement

Check the grinding wheel often and change as necessary. Wheels approved for use with the industrial sharpener are available from Wood-Mizer.

The grinding wheel should be in good condition. Replace if worn, the edges look shiny and/or the wheel is "burning" the blades. **NOTE:** The grinding wheels have a CBN (Cubic Boron Nitride) coating.

1. Before replacing the grinding wheel, shut down and lock out all power to the machine.
2. Raise the cutting head.
3. Remove the grinding wheel side guard.
4. Unscrew the oiler.
5. Remove the grinding wheel nut, washer and the grinding wheel.
6. Mount the new grinding wheel. Install the grinding wheel washer and nut and tighten to 44.2 ft-lbs (60Nm).
7. Install the oiler. **NOTE:** If the machine is equipped with a 1 3/16" (30.2 mm) wide grinding wheel, mount the oiler No. 101235. If it has a 1" (25.4 mm) wide grinding wheel, use the oiler No. 100805.
8. Install the grinding wheel side guard.

3.2 Oil Level

Periodically check the oil level. Add oil as necessary. The oil level should be kept between 8.5 and 10 litres. Use only Wood-Mizer approved oil.

Filter the oil to remove metal shavings before reusing.

3.3 Grinding Wheel Shaft Bearings

Periodically check the grinding wheel shaft bearings for wear and replace as necessary. To replace:



IMPORTANT! Before servicing, shut down and lock out the power supply.

See Figure 3-1.

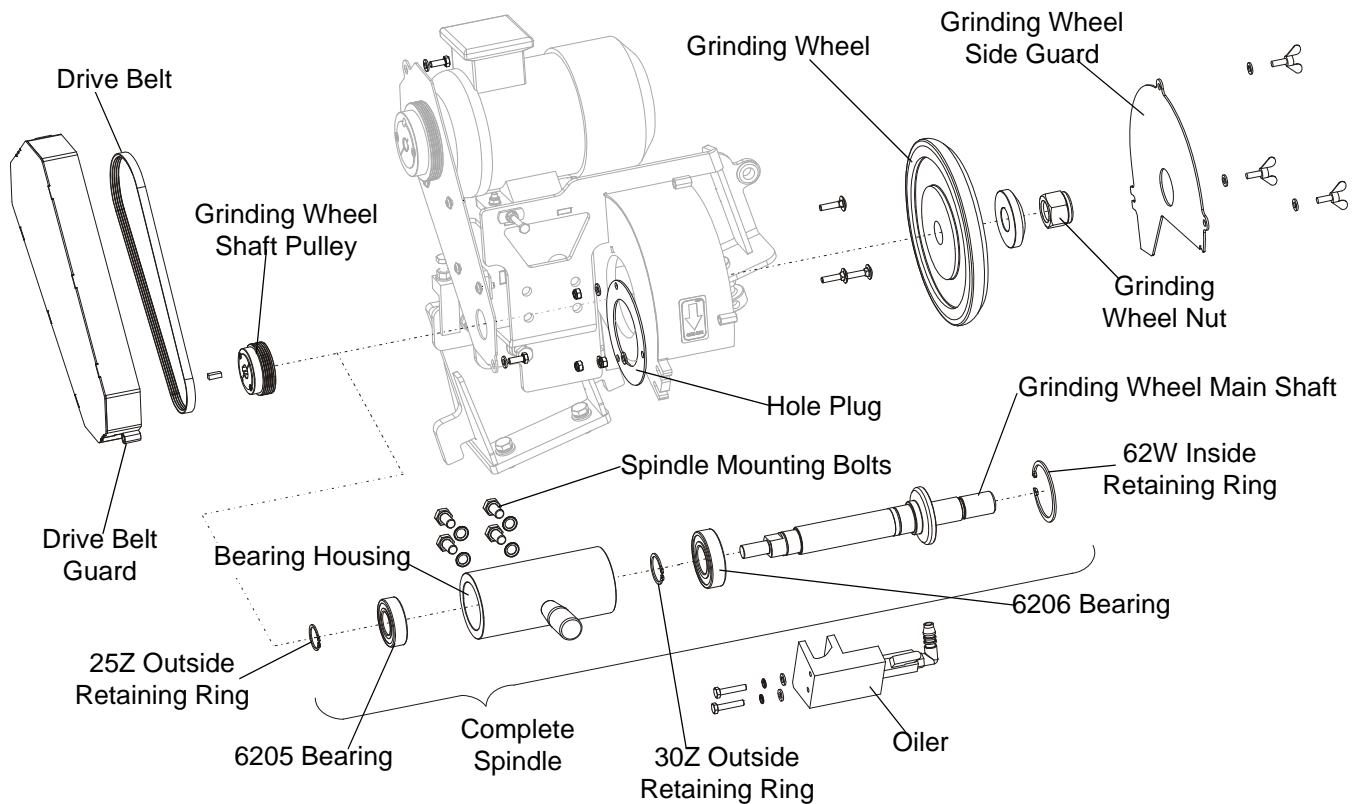

FIG. 3-1

TO DISMOUNT THE BEARINGS:

1. Remove the grinding wheel side guard.
2. Dismount the oiler.
3. Remove the grinding wheel nut.
4. Remove the grinding wheel.
5. Unbolt the drive belt guard.
6. Loosen the drive belt by moving the motor towards the spindle.
7. Remove the multi-groove drive belt.
8. Remove the pulley from the spindle.
9. Remove the hole plug mounting nuts.
10. Remove the bolts mounting the spindle to the machine body.
11. Dismount the complete sharpener spindle.

3 Replacement of Components

Grinding Wheel Shaft Bearings

12. Remove the hole plug from the spindle.
13. Remove the 25Z outside retaining ring.
14. Remove the 62W inside retaining ring.
15. Dismount the main shaft from the bearing housing.
16. Remove the 6205 bearing.
17. Remove the 30Z outside retaining ring.
18. Remove the 6206 bearing from the main shaft.

TO INSTALL THE BEARINGS:

19. Mount the new 6206 bearing on the main shaft.
20. Install the 30Z outside retaining ring.
21. Mount the main shaft, along with the bearing, in the bearing housing.
22. Install the 62W inside retaining ring.
23. Install the 6205 bearing.
24. Secure with the 25Z outside retaining ring.
25. Slide the hole plug onto the bearing housing, from the grinding wheel's side.
26. Mount the complete spindle to the sharpener head. Tighten the spindle mounting bolts to 29.5 ft-lbs (40Nm) torque.
27. Secure the hole plug with the mounting nuts.
28. Install the pulley.
29. Install and tension the drive belt. [See Section 2.5.](#)
30. Mount the drive belt guard.
31. Install the grinding wheel and tighten the mounting nut to 44.2 fl-lbs (60Nm) torque.
32. Mount and set the oiler.
33. Mount the grinding wheel side guard.

Once bearing replacement is complete, be sure to check head alignment.

SECTION 4 MAINTENANCE & TROUBLESHOOTING

4.1 Sharpener Maintenance

Daily:

- Remove the blade, wipe the sharpener dry, lower the head, close the guard and unplug the machine after each day's use.
- Clean the sharpener. Remove any rust and metal filings.
- Regularly unbolt the moving clamp plate and clean out any buildup that might cause the clamp to not clamp the blade firmly.

Weekly:

- Clean the viewfinder window and the diode lamp.
- Remove any buildup and metal filings from the oil filter pan and magnets.
- Clean any sediment from the coolant drip pans.
- Keep the oil at such a level that the pump strainer is completely covered with the oil. The oil level should be 120-150mm (4.724" - 5.905") measured from the bottom of the tank. Replace the oil completely every six months. Dispose of worn-out oil in compliance with applicable regulations.
- Check the sharpener head stop function (stop bolt). [See Section 5.1.](#)

Monthly:

- Inspect the bearings of the grinder motor, spindle, cam and indexer drive assembly, sharpener head lever.
- Check motor and indexer brushes.
- Check all plugs and switches.
- Check the radial run-out and the axial run-out of the spindle shaft at the location where the grinding wheel is mounted. Do it once a month with a dial indicator mounted on a magnetic stand. The maximum allowable run-out must be no greater than +/- .01mm (0.000393").
- Inspect the carbide cutting plate of the deburr assembly.



CAUTION! Regularly clean or replace the filter of the oil vapours exhaust system (according to the manufacturer's recommendations).

4.2 Blade Sharpening Tips

This section covers some of the common problem areas of blade sharpening.

Before removing from the sawmill, clean the blade by running the water lube on it for 15 seconds. This will remove most of the sap buildup that would otherwise have to be scraped off when it dries. Then wipe the blade with a clean, dry rag.

Make sure the flow of oil through the oiler assembly is strong.

Sharpen the blade when it first shows signs of dullness. If the blade is extremely dull, due to hitting a rock or some form of foreign matter, sharpen the blade twice lightly instead of trying to remove much in one grind. Grinding too much material at once may cause the circuit breaker in the control box to kick out. If this happens, wait 15 seconds. Then turn the circuit breaker on (push it down).

SECTION 5 ALIGNMENT

Align the sharpener monthly to ensure quality performance. Besides, realign the sharpener whenever it is necessary (i.e., after the grinding wheel has been impacted by the index arm).

5.1 Saw Head Stop Adjustment

To prevent the saw head from hitting the blade clamp, when there is not blade in the clamp, adjust the distance between the grinding wheel and the clamp. To do that, lower the sharpener head all the way down by rotating the cam. Then use the adjustment bolt shown below to perform the adjustment.

The distance from the grinding wheel to the clamp should be **2.0-3.0 mm (0.079" - 0.12")**.

Check this distance once a month and adjust if necessary.

See Figure 5-1. The figure below shows adjustment of the saw head stop bolt.

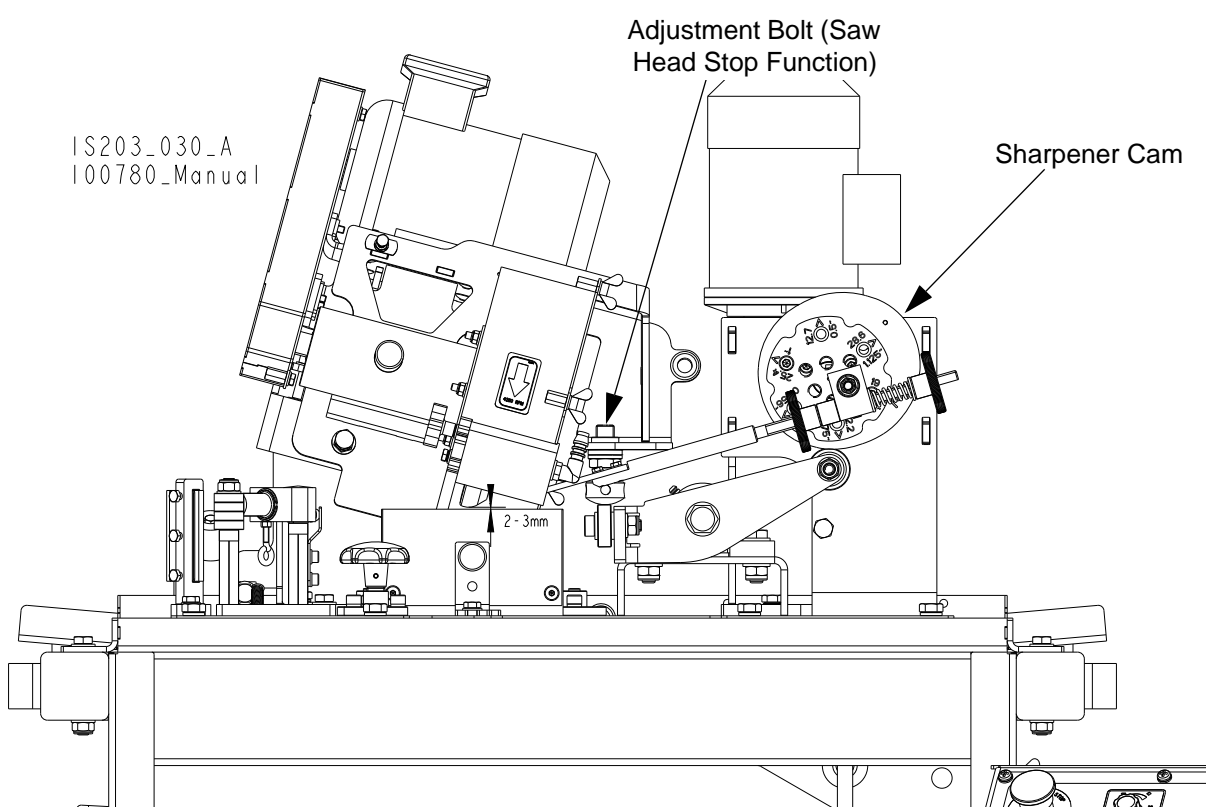

FIG. 5-1



ALIGNMENT

Saw Head Stop Adjustment

SECTION 6 BLADE HANDLING

This section covers coiling the blade, uncoiling the blade and inverting the blade.



WARNING! Always wear gloves and eye protection when handling bandsaw blades. Keep people away from work area when coiling or moving blades.

6.1 Coiling The Blade

See Figure 6-1. Raise the blade in front of you, with the teeth pointed upward. (About 1/3 to 1/4 of the blade should be between your hands.) Hold your hands about shoulder-width apart. Place your thumbs on the outside of the blade and your fingers on the inside of the blade. Squeeze the blade inward, making it oval-shaped.



FIG. 6-1

6 Blade Handling

Coiling The Blade

See Figure 6-2. Keeping your wrists locked in position, turn your forearms upward and inward. (The teeth will rotate inward and the bottom of the blade will rotate outward.)



FIG. 6-2

See Figure 6-3. Bring your hands together. The blade will form three loops. Snap the bottom loop upward and catch the three-loop coil in your hands.



FIG. 6-3

6.2 Uncoiling The Blade

See Figure 6-4. Take the three-loop coil in your right hand. Place the band against your palm with the blade teeth pointing outward toward your fingers. Slide the top loop off and let drop.



FIG. 6-4

See Figure 6-5. The remaining two loops of the blade will form a cross. Hold this crossed section out in front of you with the blade teeth pointing toward you. If the right side is crossed OVER the left, hold the crossed section with your right hand. (If the left side of the blade is crossed OVER the right, hold the crossed section with your left hand.)



FIG. 6-5

6

Blade Handling *Uncoiling The Blade*

See Figure 6-6. Keeping the blade in its crossed position, take hold of the side crossed UNDER with your other hand. Use your right (or left) hand to hold only the side crossed OVER. Place your thumbs on the top side of the blade. Put your fingers on the underneath side of the blade.

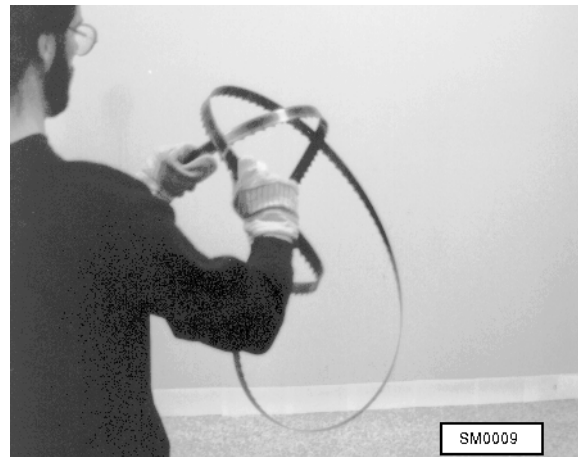

FIG. 6-6

See Figure 6-7. Hold the blade out and away from you. Slowly move your hands apart while rotating your forearms down and outward.



FIG. 6-7

6.3 Inverting The Blade

See Figure 6-8. Hold the blade in front of you. Let one side rest on the ground, teeth pointing toward you. Place your thumbs on the outside of the blade. Put your fingers on the inside of the blade.



FIG. 6-8

See Figure 6-9. Hold the blade with your hands a little farther than shoulder-width apart. Then bring your hands toward each other while rotating your thumbs downward. This causes the middle of the blade to curve downward.

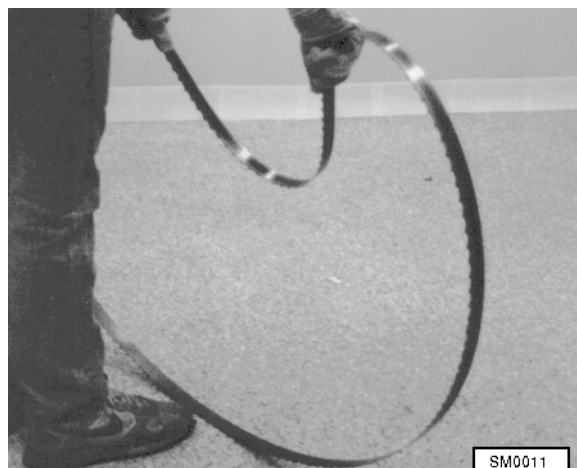

FIG. 6-9

6 Blade Handling

Inverting The Blade

See Figure 6-10. Keeping your hands close together, rotate the curved section of the blade up and away from you. The blade will be in an oval shape, but twisted.



FIG. 6-10

See Figure 6-11. Slowly move your hands apart, allowing the blade to untwist.

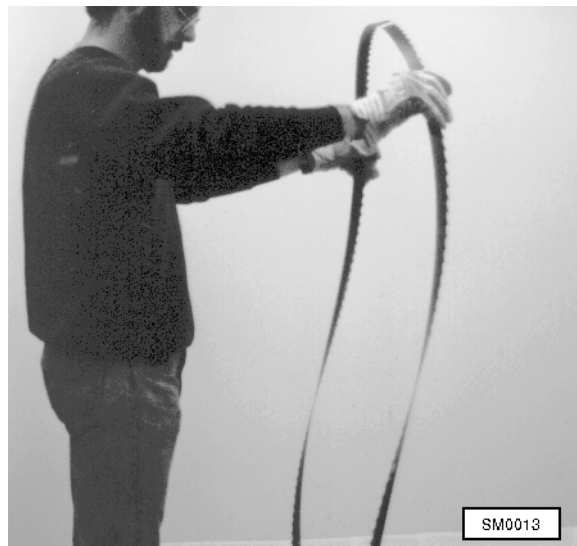

FIG. 6-11

6.4 Storing Blades

Use care when moving, storing, or handling blades. When blades are stacked or thrown together, the tips can be dulled or the set changed.

Stack two blades back-to-back using dividers between each set of blades to prevent the teeth from contacting each other.

SECTION 7 REPLACEMENT PARTS

7.1 How to use the Parts List

- Use the table of contents or index to locate the assembly that contains the part you need.
- Go to the appropriate section and locate the part in the illustration.
- Use the number pointing to the part to locate the correct part number and description in the table.
- Parts shown indented under another part are included with that part.
- Parts marked with a diamond (◆) are only available in the assembly listed above the part.

See the sample table below. Sample Part #A01111 includes part F02222-2 and subassembly A03333. Subassembly A03333 includes part S04444-4 and subassembly K05555. The diamond (◆) indicates that S04444-4 is not available except in subassembly A03333. Subassembly K05555 includes parts M06666 and F07777-77. The diamond (◆) indicates M06666 is not available except in subassembly K05555.

7.2 Sample Assembly				
REF.	DESCRIPTION (◆ Indicates Parts Available In Assemblies Only)	PART #	QTY.	
	SAMPLE ASSEMBLY, COMPLETE (INCLUDES ALL INDENTED PARTS BELOW)	A01111	1	
1	Sample Part	F02222-22	1	
	Sample Subassembly (Includes All Indented Parts Below)	A03333	1	
2	Sample Part (◆ Indicates Part Is Only Available With A03333)	S04444-4	1	◆
	Sample Subassembly (Includes All Indented Parts Below)	K05555	1	
3	Sample Part (◆ Indicates Part Is Only Available With K05555)	M06666	2	◆
4	Sample Part	F07777-77	1	

To Order Parts:

- From Europe call your local distributor or our European Headquarters and Manufacturing Facility in Kolo, Nagórna 114 St, Poland at **+48-63-2626000**. From the continental U.S., call our U.S. Headquarter 8180 West 10th St.Indianapolis, IN 46214, toll-free at **1-800-525-8100**. Have your customer number, vehicle identification number, and part numbers ready when you call.
- From other international locations, contact the Wood-Mizer distributor in your area for parts.

Office Hours:

Country	Monday - Friday	Saturday	Sunday
Poland	7 a.m.- 3 p.m.	Closed	Closed
US	8 a.m.- 5 p.m.	8 a.m.- 5 p.m	Closed

7.3 Stand Assembly

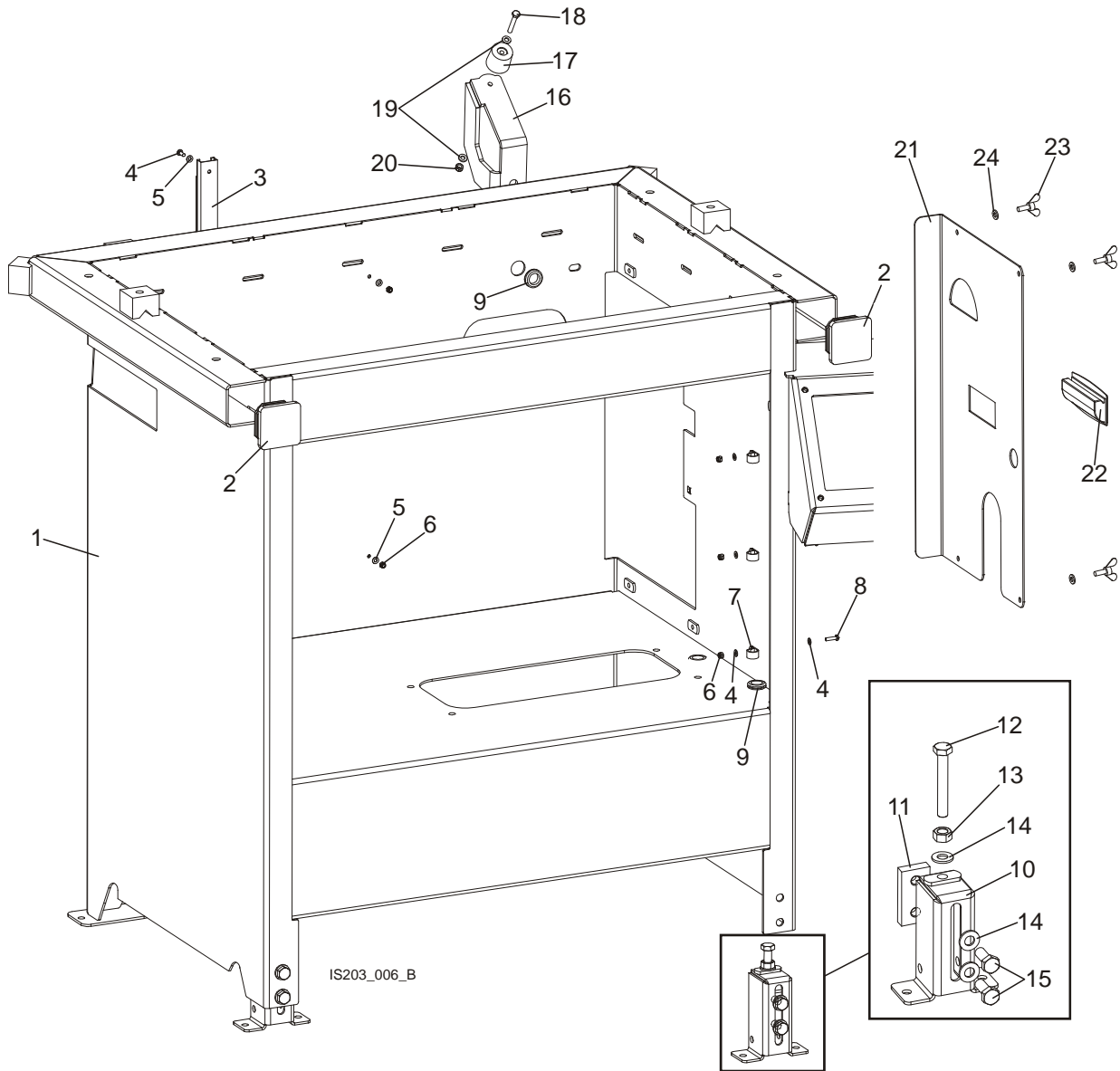

REF.	DESCRIPTION (◆ Indicates Parts Available In Assemblies Only)	PART #.	QTY.
	SHARPENER STAND BMS500/600-COMPLETE	101264	1
1	STAND, SHARPENER BMS500/600	101265-1	1
2	CAP, SR 1540 OUTRIGGER LEG	089710	2
3	WIRE HOUSING, SHARPENER BASE	500465	1
4	SCREW, M4x12 -5,8-B- CROSS RECESSED PAN	F81011-43	8
5	WASHER 4,3 FLAT ZINC	F81051-2	14
6	NUT, M4-B HEX NYLON ZINC LOCK	F81029-1	7
7	CLAMP, #3307 HEYMAN WIRE	F05114-1	3
8	SCREW, M4x16 5,8-B CROSS RECESSED PAN	F81011-42	3
9	GROMMET, 5/8" ID RUBBER	P11764	4
	FOOT, ADJUSTABLE COMPLETE	101237	2



REPLACEMENT PARTS

Stand Assembly

10	FOOT, ADJUSTABLE SHARPENER	101238-1	1	
11	PLATE, CLAMPING M10-ZINC	101242-1	1	
12	BOLT, M10x70-8.8-HEX HEAD FULL THREAD ZINC	F81003-20	1	
13	NUT, M10-8-B-HEX ZINC	F81033-3	1	
14	WASHER, 10,5 FLAT ZINC	F81055-1	3	
15	BOLT, M10x25-8.8-HEX HEAD FULL THREAD ZINC	F81003-11	2	
	SUPPORT, HEAD COVER COMPLETE	500468	1	
16	SUPPORT, HEAD COVER	500461-1	1	
17	BUMPER. COVER BRACKET	087825	1	
18	BOLT, M6x40-8.8-HEX HEAD FULL THREAD ZINC	F81001-5	1	
19	WASHER, 6,4 FLAT ZINC	F81053-1	2	
20	NUT, M6-8-B-HEX NYLON ZINC LOCK	F81031-2	1	
	COVER, SIDE COMPLETE	101280	1	
21	COVER, SIDE	101281-1	1	
22	HANDLE, EPR.90-PF-C1(261051-C1) FLUSH PULL	100012	1	
23	BOLT, M6x16 BN276 DIN 316	F81001-16	4	
24	WASHER, 6,4 FLAT ZINC	F81053-1	4	

7.4 Cover Assembly

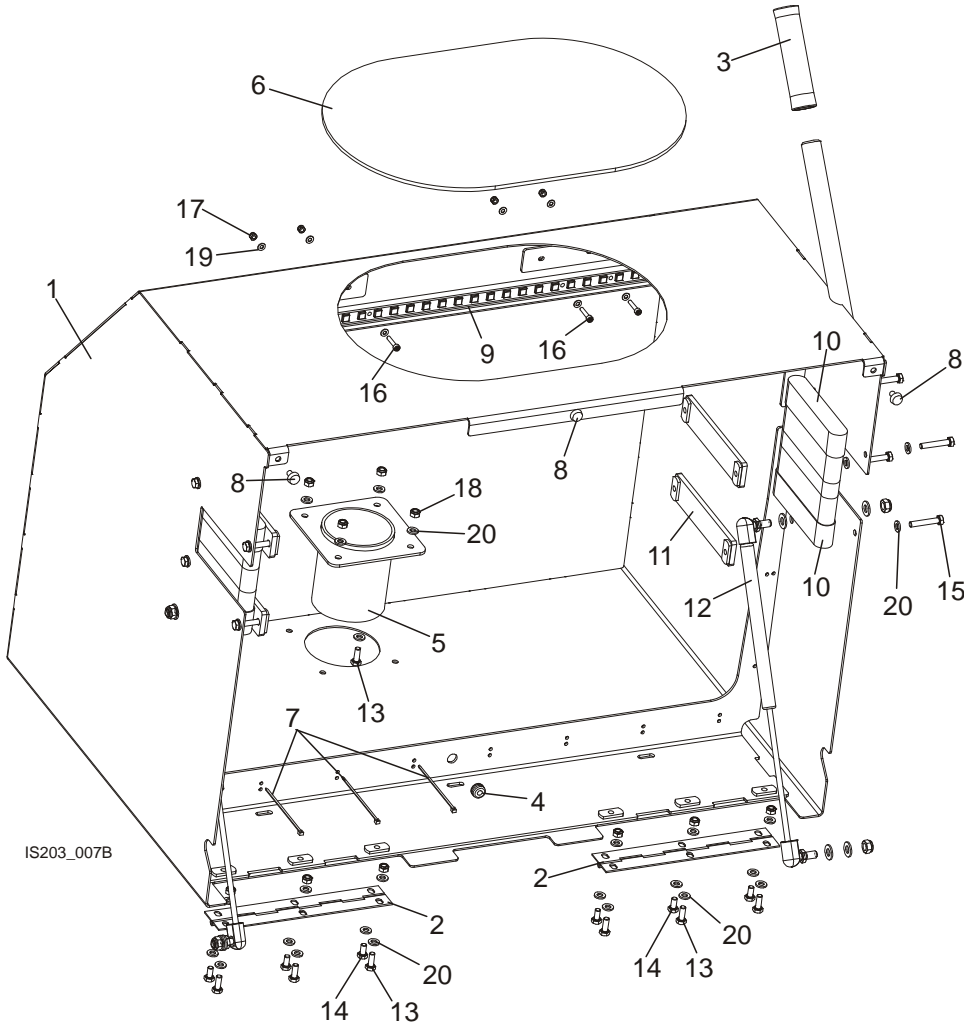

REF.	DESCRIPTION (◆ Indicates Parts Available In Assemblies Only)	PART #.	QTY.
	SHARPENER COVER, COMPLETE	100850	1
1	SHARPENER COVER	100851-1	1
2	HINGE, COVER	088257	2
3	GRIP, LONG HANDLE	086164	1
4	SEAL WIRE, GH6	085338	1
5	PIPE, FUME EXHAUST CONNECTION	087974-1	1
6	VIEWFINDER, TOP COVER	505180	1
7	CABLE TIE, TKUV 9/3	F81082-4	11
8	FEET, SRI591 12X6 GROMMET	101279	3
9	STRIP, SUPERFLUX24 LED LLSFW-24-3WC	101283	1
10	CLEANER, BLADE	101284	4
11	BRACKET, BLADE CLEANER PTD	101285-1	4
12	SPRING, 150N - COMPLETE GAS LIFTING	500464	2
13	BOLT, M6x16 8.8 HEX HEAD FULL THREAD ZINC	F81001-15	10
14	BOLT, M6x12-8.8-HEX HEAD FULL THREAD ZINC	F81001-7	6

7 REPLACEMENT PARTS

Cover Assembly

15	BOLT, M6x35 8.8 HEX HEAD ZINC	F81001-71	8	
16	SCREW, M4x20 8,8 HEX SOCKED HEAD ZINC	F81011-31	4	
17	NUT, M4-B HEX NYLON ZINC LOCK	F81029-1	4	
18	NUT, M6-8-B-HEX NYLON ZINC LOCK	F81031-2	10	
19	WASHER, 4,3 FLAT ZINC	F81051-2	8	
20	WASHER, 6,4 FLAT ZINC	F81053-1	34	

7.5 Blade Support Assembly

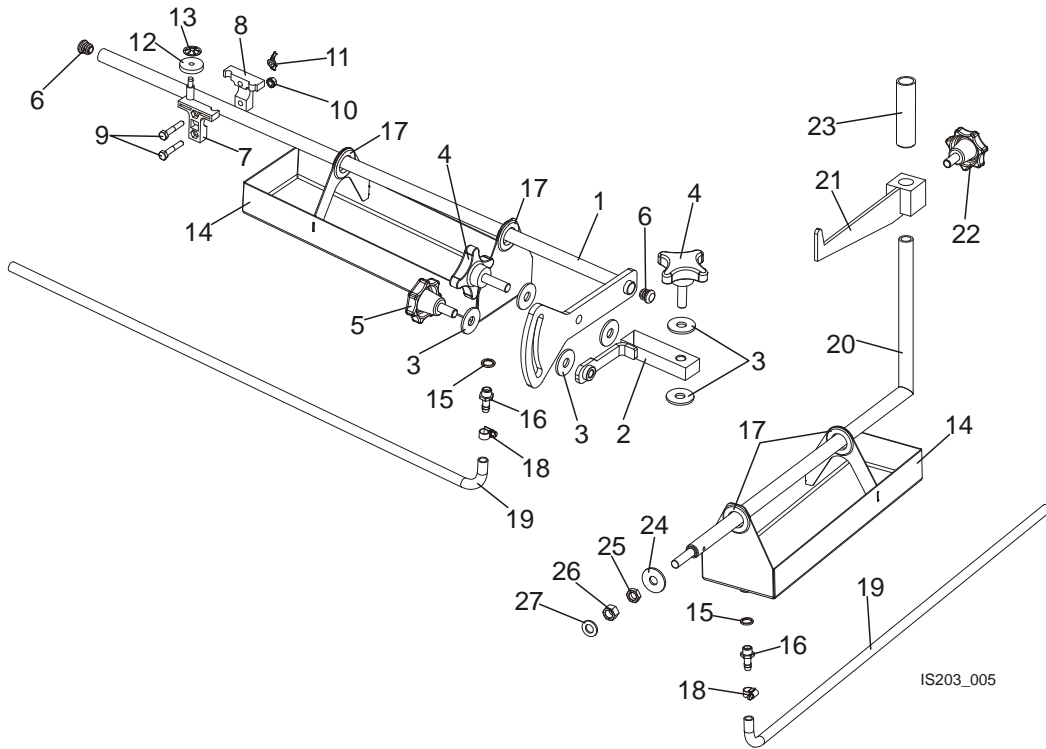

IS203_005

REF.	DESCRIPTION (◆ Indicates Parts Available In Assemblies Only)	PART #.	QTY.
	BLADE SUPPORT, SIDE COMPLETE	101261	2
1	SUPPORT, BLADE SIDE ZINC	100844-1	1
2	BRACKET, BLADE SIDE SUPPORT	101247-1	1
3	WASHER, 13 SPECIAL FLAT	F81056-14	6
4	KNOB, SR1580, 80X40 M12	100848	2
5	KNOB, SR1580 63x25 M12	500460	1
6	CAP, SR1530 18x2	100847	2
	SUPPORT ASSEMBLY, BLADE REPLACEMENT	A10617	1
7	Guide, Blade Support w/Post	S10611	1
8	Guide, Blade Support w/o Post	S10612	1
9	Bolt, 1/4-20 x 1 1/2" Hex Head Zinc	F05005-5	2
10	Nut, 1/4-20 Self-locking zinc	F05010-9	1
11	Nut, 1/4-20 Wing	F05010-13	1
12	Wheel, Blade Support	S10539	1
13	Nut, 1/4" Push	P10614	1
	PAN, COOLANT DRIP COMPLETE	101256	2
14	PAN, COOLANT DRIP	101257-1	1
15	SEAL, G1/4 PD13	090809	1
16	BUSHING, GT13/09 NR 13539	092783	1
17	GROMMET, RUBBER 1" ID	P11765	2
18	CLAMP, 8-12mm PLASTIC HOSE	F81080-1	1
19	HOSE, OIL FLOW	101260	1
	SUPPORT, BLADE COMPLETE BACK	101262	2

7 REPLACEMENT PARTS

Additional Blade Support Assembly (Option)

20	PIPE, SUPPORT	087584-1	1	
21	REST WELDMENT, BLADE	101243-1	1	
22	KNOB, 63mm M12x25 SR 1580	500460	1	
23	PIPE, BLADE WEAR REAR	087590	1	
24	WASHER, 13 SPECIAL FLAT ZINC	F81056-14	1	
25	NUT, M12-04-A HEX THIN ZINC	F81034-6	1	
26	NUT, M12-8-B HEX ZINC	F81034-1	1	
27	WASHER, 13 FLAT ZINC	F81056-1	1	

7.6 Additional Blade Support Assembly (Option)

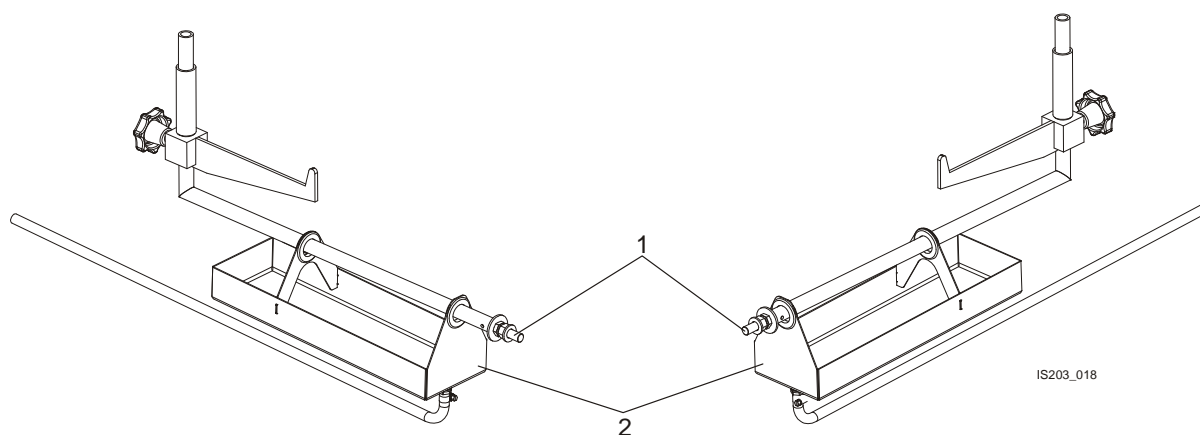

REF.	DESCRIPTION (◆ Indicates Parts Available In Assemblies Only)	PART #.	QTY.	
	ADDITIONAL BLADE SUPPORT ASSEMBLY, COMPLETE	500469	1	
1	SUPPPORT, BLADE REAR COMPLETE	101262	2	
2	PAN, COOLANT DRIP	101256	2	

7.7 Electric Box

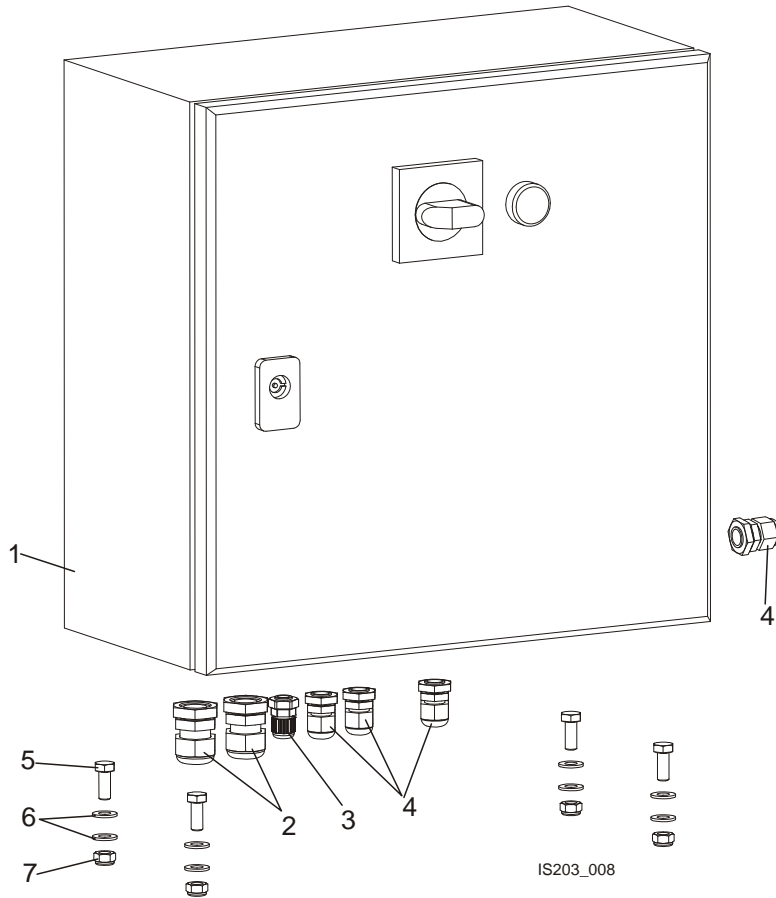

REF.	DESCRIPTION (◆ Indicates Parts Available In Assemblies Only)	PART #.	QTY.
	CONTROL BOX, SHARPENER BMS500AU	101141-M21 ¹	1
	CONTROL BOX, SHARPENER BMS500BS	101141-M2 ²	1
	CONTROL BOX, SHARPENER BMS500CU	101141-M4 ³	1
	CONTROL BOX, SHARPENER BMS500HS	101141-M ⁴	1
	CONTROL BOX, SHARPENER BMS600AU	101141-M21 HD ⁵	1
	CONTROL BOX, SHARPENER BMS600BU	101141-M2 HD ⁶	1
	CONTROL BOX, SHARPENER BMS500HS	101141-M4 HD ⁷	1
1	BOX, SHARPENER CONTROL	101141	1
2	GLAND, DP 16/H SEAL	F81096-7	2
3	GLAND, DP7/H SEAL	F81096-11	1
4	GLAND, DP 9/H SEAL	F81096-2	4
5	BOLT, M8x20-8.8-B-HEX HEAD FULL THREAD ZINC	F81002-4	4
6	WASHER, 8,4-FLAT ZINC	F81054-1	8
7	NUT, M8-8-B-HEX NYLON ZINC LOCK	F81032-2	4

¹ Includes components listed in [8.2 Electrical Component List, BMS500A](#).
² Includes components listed in [8.8 Electrical Component List, BMS500BS](#).
³ Includes components listed in [8.10 Electrical Component List, BMS500C](#).
⁴ Includes components listed in [8.14 Electrical Component List, BMS500HS](#).
⁵ Includes components listed in [8.16 Electrical Component List, BMS600AU](#).
⁶ Includes components listed in [8.18 Electrical Component List, BMS600BU](#).

7 REPLACEMENT PARTS

Control Panel

⁷ Includes components listed in [8.20 Electrical Component List, BMS600CU](#).

7.8 Control Panel

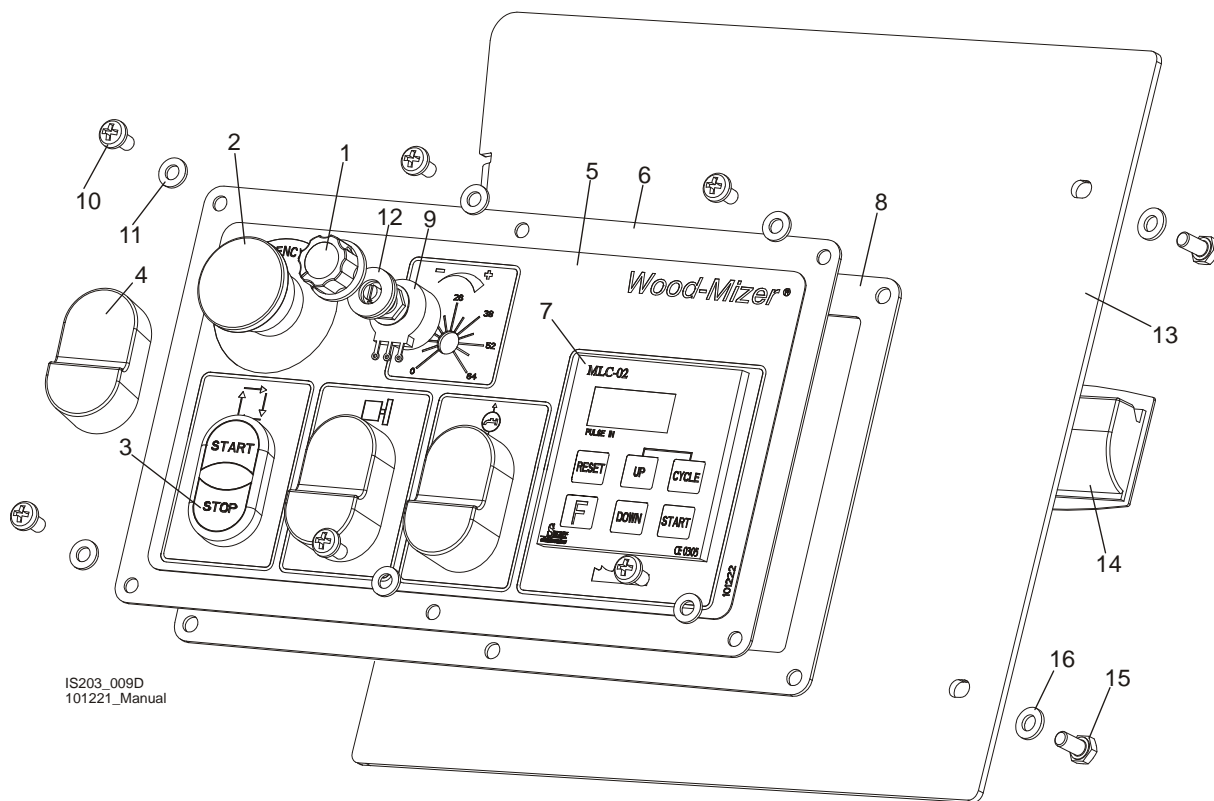

IS203_009D
101221_Manual

REF.	DESCRIPTION (◆ Indicates Parts Available In Assemblies Only)	PART #.	QTY.
	CONTROL PANEL, SHARPENER	101221	1
	CONTROL PANEL, SHARPENER, BMS 500/600 BU	513418	1
	CONTROL PANEL, SHARPENER, BMS 500/600 CU	513419	1
	CONTROL PANEL, SHARPENER, BMS 500/600 AU	513420	1
1	KNOB, 1/4"ID FLUTED ROUIND PLASTIC	033478	1
2	SWITCH, XB4 BS542 EMERGENCY	086556	1
3	SWITCH, 24V START/STOP	090452	3
4	MEMBRANE M22-T-DD	090462	3
5	DECAL, SHARPENER CONTROL PANEL	101222	1
6	COVER, CONTROL PANEL FRONT	101288-1	1
7	CONTROLLER, MLC-02 SHARPENER	098692	1
8	GASKET, SHARPENER CONTROL PANEL	101289	1
9	POTENTIOMETER, 1k	E20519	1
10	SCREW, ISO 7045-M6x12-4.8	F81001-40	6
11	WASHER, M6, FLAT,ZINC	F81053-1	6
12	WASHER, 10.5 FLAT ZINC	F81055-1	2
	COVER, CONTROL PANEL REAR COMPLETE	101291	1
13	COVER, CONTROL PANEL REAR	101290-1	1
14	HANDLE, EPR.90-PF-C1(261051-C1) FLUSH PULL	100012	1
15	BOLT, M6x12-8.8-HEX HEAD FULL THREAD ZINC	F81001-7	3
16	WASHER, 6,4 FLAT ZINC	F81053-1	3

7.9 Coolant Tank

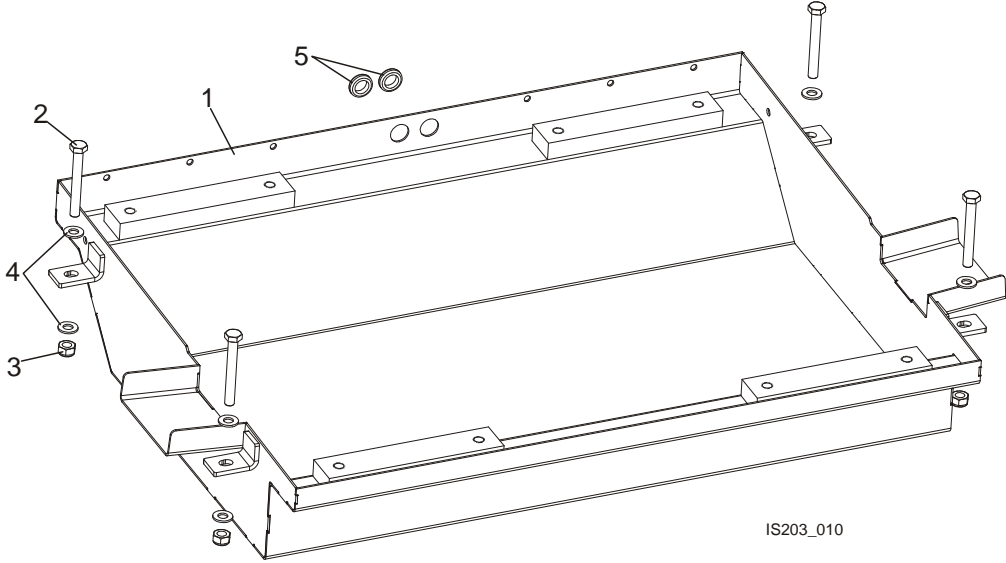

IS203_010

REF.	DESCRIPTION (◆ Indicates Parts Available In Assemblies Only)	PART #.	QTY.
	TANK, COOLANT BMS500/600, SHARPENER COMPLETE	101245	1
1	TANK, COOLANT	100839-1	1
2	BOLT, M10x80 -8.8- HEX HEAD ZINC	F81003-50	4
3	NUT, M10-8-B -HEX NYLON ZINC LOCK	F81033-1	4
4	WASHER, 10,5 FLAT ZINC	F81055-1	8
5	GROMMET, 5/8" ID RUBBER	P11764	2

7.10 Mounting Plate

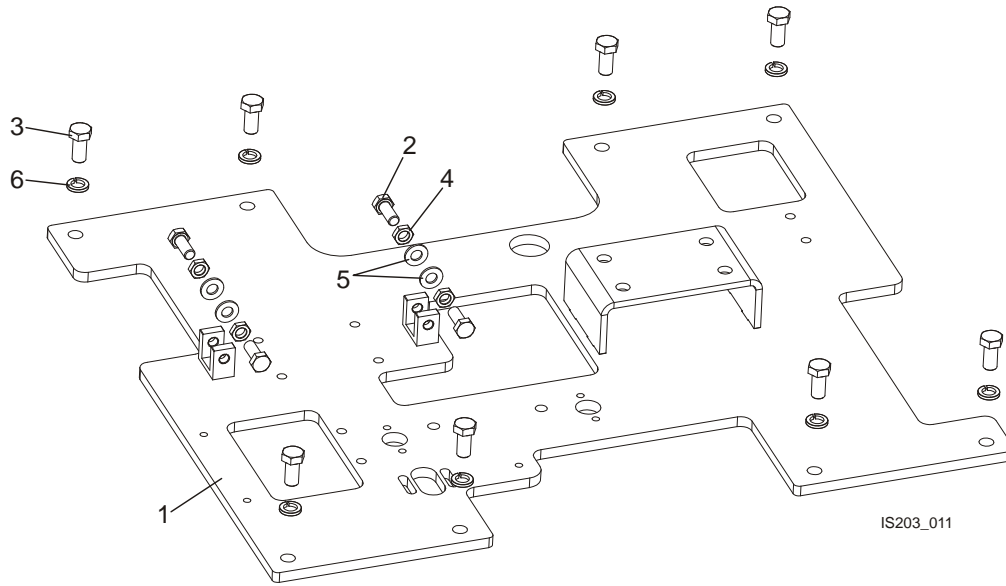

REF.	DESCRIPTION (◆ Indicates Parts Available In Assemblies Only)	PART #.	QTY.	
	PLATE, SHARPENER MOUNTING - COMPLETE	100843	1	
1	PLATE, MOUNTING ZINC	100837-1	1	
2	BOLT, M10x1x25 DIN 933	F81003-28	4	
3	BOLT, M12x25-8.8-HEX HEAD FULL THREAD ZINC	F81004-31	8	
4	NUT, M10x1-04-ST-A2 ISO 8675 THIN	F81033-10	4	
5	WASHER, 10,5 FLAT ZINC	F81055-1	4	
6	WASHER Z12,2 SPLIT LOCK ZINC	F81056-2	8	

7.11 Sharpener Head

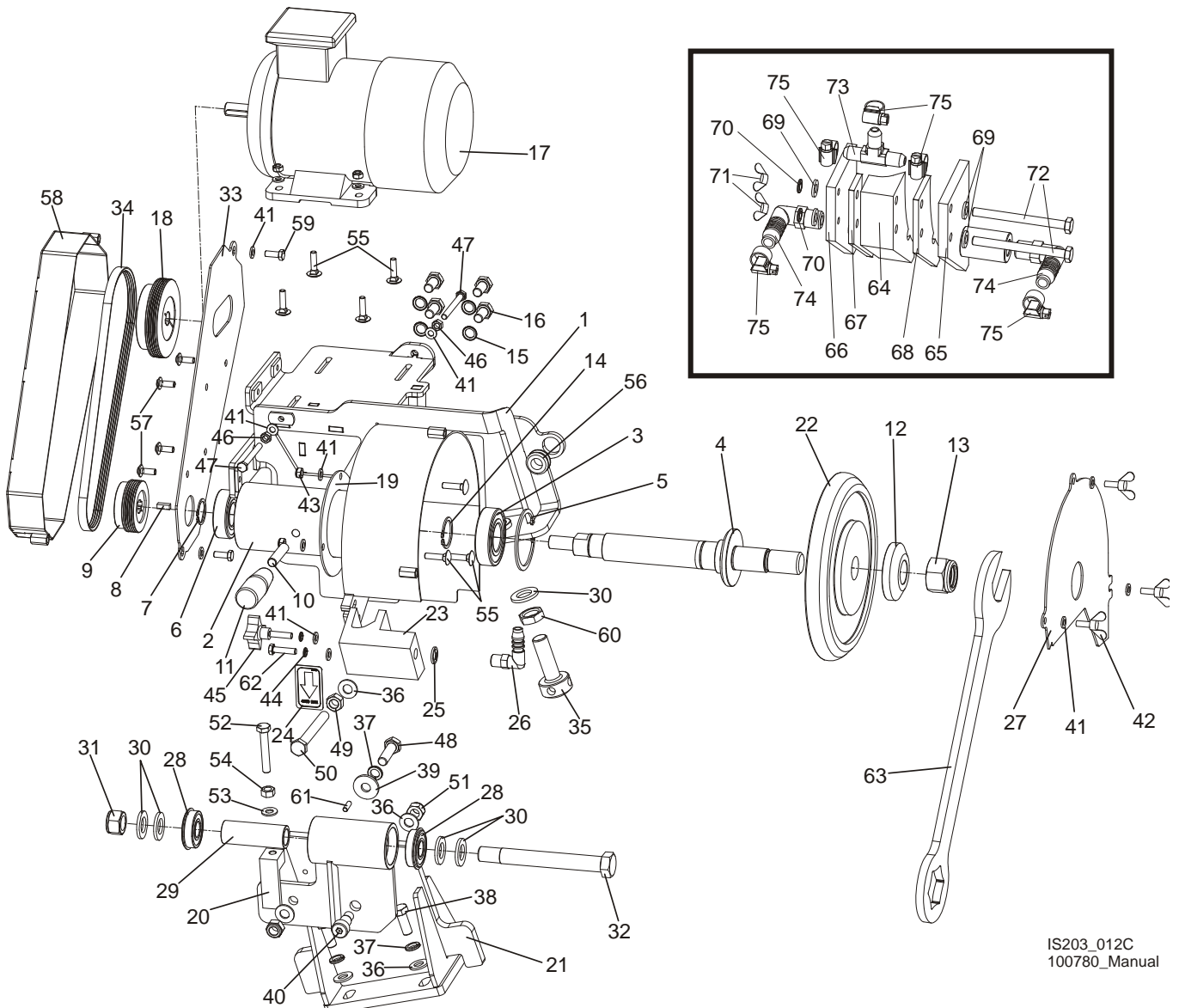

IS203_012C
 100780_Manual

REF.	DESCRIPTION (◆ Indicates Parts Available In Assemblies Only)	PART #.	QTY.
	SHARPENER HEAD BMS500, COMPLETE	100781	1
	SHARPENER HEAD BMS600 COMPLETE	100781-RS	1
1	HOUSING, SHARPENER HEAD	100782-1	1
	SPINDLE, BMS500/600 SHARPENER COMPLETE	100785	1
2	SLEEVE, BEARING ZINC	100783-1	1
3	BEARING, 6206 2RSR P6 ROLLING	100787	1
4	SHAFT, SPINDLE COMPLETE	100784	1
5	RING, W62 SPRING RETAINING	F81090-1	1
6	BEARING, 6205 2RSR P6 ROLLER	087353	1
7	RING, Z25 OUTSIDE RETAINING	F81090-22	1
8	KEY, B 5x5,1x14	087365	1



REPLACEMENT PARTS

Sharpener Head

9	PULLEY, PYB 56-4J TAPER-LOCK 14	100811	1	
10	BOLT, M10x35-8.8 ZINC	F81003-9	1	
11	GRIP, L70 THREAD M10 13870M10	089445	1	
12	PLATE, GRINDING WHEEL CLAMPING, ZINC	100806-1	1	
13	NUT, M24x2-8-B-Fe/Zn5 PN/M-82144	F81039-11	1	
14	RING, Z30 SPRING RETAINING	F81090-23	1	
15	WASHER, 791 M10/10.5 RIBBED LOCK	F81055-7	4	
16	BOLT, ISO4017-M10x20-8.8-A2E HEX HEAD	F81003-53	4	
17	MOTOR, Sh7IX-2C BESEL	087358	1	
18	PULLEY, PYB 85-4J TAPER-LOCK 14	100788	1	
19	PLUG	100803-1	1	
20	BUSHING, SHARPENER VERTICAL PIVOT	088339-1	1	
21	BRACKET, SHARPENER HEAD	100794-1	1	
22	WHEEL, 8" 10°/30° 7/8" TS .250TH- BACK ANG GRINDING	030310	1	
	WHEEL, 8" 13°/29° 7/8TS .300TH GRINDING	030388	1	
	WHEEL, 8" 12°/28° .656TS .200TH GRINDING	030394	1	
	WHEEL, 8" 4°/32° 7/8TS .250TH GRINDING	050145	1	
	WHEEL, 8" 7°/34° 7/8" TS .295TH GRINDING	053096	1	
	WHEEL, 8" 10°/30° 3/4TS .260TH GRINDING	053359	1	
	WHEEL, 8" 10°/30° 1/2TS .160TH GRINDING	053412	1	
	WHEEL, 8" 7°/34° 1-1/8TS .330TH GRINDING	053447	1	
	WHEEL, 8" 7°/39.5° 7/8" TS .33TH GRINDING	066267	1	
	WHEEL, 8" 9°/29° 7/8TS .220TH GRINDING	P30188	1	
	WHEEL, 8" 10°/30° 1-1/8TS .330TH GRINDING	052861	1	
	WHEEL, 8" 13°/29° 1-1/8TS .330TH GRINDING	052672	1	
23	OILER,CBN 8" - SHARPENER STANDARD	100805	1	
	OILER, CBN 8" 1.125" SHARPENER	101235	1	
24	DECAL KIT, GRINDING WHEEL ROTATION	S20097K ¹	1	
25	SEAL, G1/4 PD13	090809	1	
26	FITTING, WES 10/R 1/4 ELBOW	088379	1	
27	COVER, SIDE GUIDE	100807-1	1	
28	BEARING, 6203 DDUNR NSK W/SNAP RING	086395	2	
29	BUSHING, SHARPENER HEAD SPACER	092672	1	
30	WASHER, 17 FLAT ZINC	F81058-1	5	
31	NUT, M16-8-HEX	F81036-2	1	
32	SCREW, M16d1f6 x140-8.8- SHOULDER Zinc	F81006-33	1	
33	GUARD, SIDE BELT GRINDER	100808-1	1	
34	BELT, 4PJ660 (OPTIBELT)	100804	1	
35	BOLT, M16X50, MUSHROOM ZINC	101219-1	1	
36	WASHER, 10,5 FLAT ZINC	F81055-1	7	
37	WASHER, 10.2 SPLIT LOCK ZINC	F81055-2	5	
38	BOLT, M10x25-8.8-HEX HEAD FULL THREAD ZINC	F81003-11	4	
39	WASHER, 10,5 ZINC FLAT SPECIAL	F81055-6	1	
40	SCREW, 12/M10X16 12.9 BOSSARD SHOULDER	F81003-64	1	
41	WASHER, 6,4 FLAT ZINC	F81053-1	16	
42	BOLT, M6x16 BN276 DIN 316	F81001-16	3	
43	NUT, M6-8-B-HEX NYLON ZINC LOCK	F81031-2	7	
44	WASHER, Z 6,1 SPLIT LOCK ZINC	F81053-3	2	

45	KNOB, STAR.SR38/M6x25(493936 MOSS)	515275	1	
46	NUT, M6-8-HEX ZINC	F81031-1	2	
47	BOLT, M6x60-8.8-HEX HEAD FULL THREAD ZINC	F81001-9	2	
48	BOLT, M10x35-8.8 HEX HEAD FULL THREAD ZINC	F81003-17	1	
49	NUT, M10-8-B-HEX ZINC	F81033-3	1	
50	BOLT, M10X90-8.8 HEX HEAD FULL THREAD ZINC	F81003-90	1	
51	NUT, M10-8-B -HEX NYLON ZINC LOCK	F81033-1	2	
52	BOLT, M8X50-8.8-HEX HEAD FULL THREAD ZINC	F81002-19	1	
53	WASHER, 8,4-FLAT ZINC	F81054-1	1	
54	NUT, M8-8-B-HEX ZINC	F81032-1	1	
55	BOLT, M6x25-8.8-MUSHROOM HEAD SQUARE NECK ZINC	F81001-20	4	
56	GROMMET, 20/13 RUBBER	086188	1	
57	BOLT, M6x16 BN 11252 "BOSSARD"	F81001-24	4	
58	GUARD, BELT GRINDER	100798-1	1	
59	BOLT, M6x16 8.8 Fe/Zn5 PN-M/82105	F81001-15	2	
60	NUT, M16 THIN ZINC	F81036-4	1	
61	PIN, 5x16 Fe/Zn ROLL	F81044-3	1	
62	BOLT, M6X25MM,HEX HEAD,GR 8.8,ZINC	F81001-3	1	
63	WRENCH, 36 OPEN/BOX-END ZINC-PLATED	502968-1	1	
	OILER ASSEMBLY	505670 ²	1	
64	BLOCK, OILER INSIDE	505672	1	
65	PLATE WLDMT, OILER BRACKET - RIGHT	505677	1	
66	PLATE WLDMT, OILER BRACKET - LEFT	505676	1	
67	WASHER, OILER RIGHT	505673-1	1	
68	WASHER, OILER LEFT	505674-1	1	
69	WASHER, 6.4 FLAT ZINC	F81053-1	4	
70	WASHER, Z6.1 SPLIT LOCK ZINC	F81053-3	2	
71	NUT, M8,HEX, SWAGED LOCK ZINC	F81032-3	2	
72	BOLT, M6 X 80 5.8 Fe/Zn5, PN-M/85105	F81001-61	2	
73	FITTING, 3/8 BARB TEE	015485	1	
74	FITTING WES 10/R 1/4 ELBOW	088379	2	
75	CLAMP, PLASTIC HOSE	F81080-1	5	

¹ Belongs to Sharpener Decal Kit BMS500 - 500467.

² Belongs to BMS600 Only.

7.12 Cam & Index Arm Drive Assembly

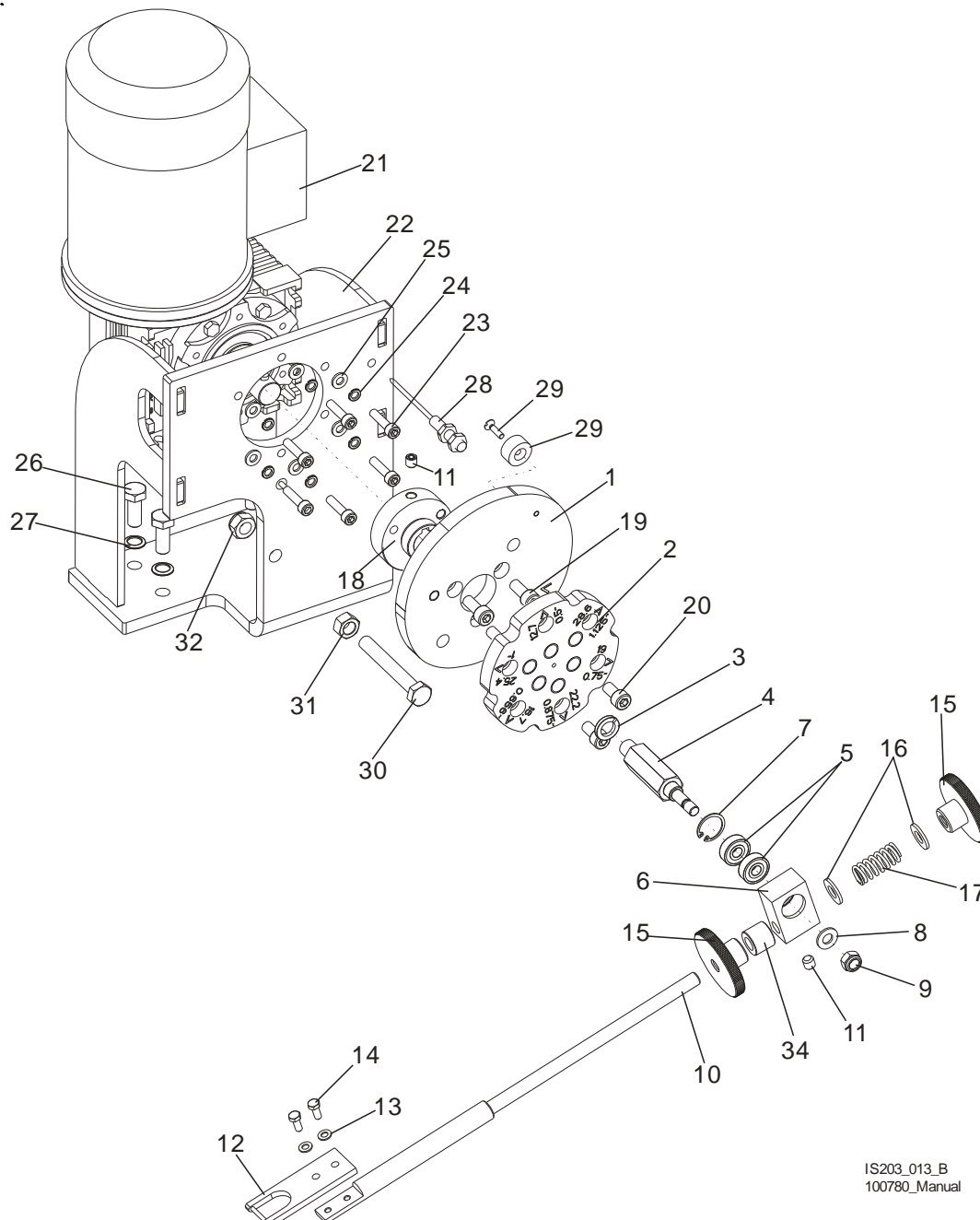

REF.	DESCRIPTION (◆ Indicates Parts Available In Assemblies Only)	PART #.	QTY.
	CAM & INDEX ARM DRIVE ASSEMBLY, COMPLETE	100820	1
1	CAM, SHARPENER BMS500/600- ZINC	509734-1	1
2	PLATE, STROKE ADJUSTMENT ZINC	511878-1	1
3	WASHER, Z12,2 SPLIT LOCK ZINC	F81056-2	1
4	SHAFT, INDEX CAM - ZINC	100821-1	1
5	BEARING, 608-2RS FLT ROLLER	086197	2
6	BLOCK, INDEX ZINC	087373-1	1

REPLACEMENT PARTS

Cam & Index Arm Drive Assembly

7

7	RING, W22 RETAINING	F81090-7	1	
8	WASHER, 8,4-FLAT ZINC	F81054-1	1	
9	NUT, M8-8-B-HEX ZINC	F81032-1	1	
10	PAWL WELDMENT, BLADE INDEX - ZINC	100814-1	1	
11	SCREW, M8x8 45H HEX SOCKET SET FLAT POINT	F81014-1	2	
12	PUSHER, BLADE COMPLETE	093358	1	
13	WASHER, 5,3 FLAT ZINC	F81052-1	2	
14	BOLT, M5x12-5.8-HEX HEAD FULL THREAD ZINC	F81000-5	2	
15	KNOB, 55xM10x1, ZINC	100813-1	1	
16	WASHER, 10,5 FLAT ZINC	F81055-1	2	
17	SPRING, BLADE PUSHER	087376	1	
18	HUB, CAM - ZINC	100822-1	1	
19	BOLT, M8x20 -8.8- SOCKET HEAD ZINC	F81002-30	3	
20	SCREW, M8x16 -8.8- HEX SOCKET HEAD CAP ZINC	F81002-39	2	
21	MOTOREDUCER, MR-40/21/0,25-1400/F4/V5	100810	1	
22	BRACKET, MOTOREDUCER	100834-1	1	
23	SCREW, M6x25 -8.8-HEX SOCKET HEAD CAP ZINC	F81001-41	6	
24	WASHER, Z 6,1 SPLIT LOCK ZINC	F81053-3	6	
25	WASHER, 6,4 FLAT ZINC	F81053-1	6	
26	BOLT, M10x25-8.8-HEX HEAD FULL THREAD ZINC	F81003-11	4	
27	WASHER, 791 M10/10.5 RIBBED LOCK	F81055-7	4	
28	SENSOR, SMC08S MAGNETIC	101252	1	
29	MAGNET, M20 SENSOR	101253	1	
30	BOLT, M10x75-8.8- HEX HEAD ZINC	F81003-15	1	
31	NUT, M10-8-B-NUT ZINC	F81033-3	1	
32	NUT, M10-8-B -HEX NYLON ZINC LOCK	F81033-1	1	
33	SCREW, M4x16 5.8-B SLOTTED	F81011-4	1	
34	BUSHING, ZINC-PLATED SPACER	094255-1	1	

7 REPLACEMENT PARTS

Sharpener Head Lever

7.13 Sharpener Head Lever

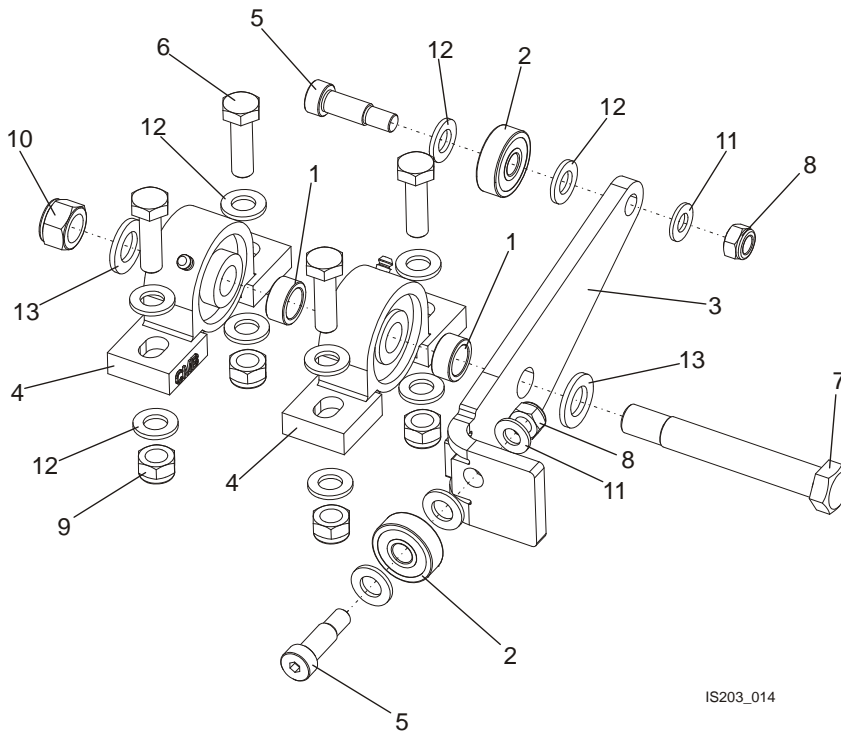

IS203_014

REF.	DESCRIPTION (◆ Indicates Parts Available In Assemblies Only)	PART #.	QTY.
	SHARPENER HEAD LEVER, COMPLETE	100809	1
1	SPACER	087965-1	2
2	BEARING, 6301-DDU (NSK) ROLLING	100816	2
3	LEVER, ANGLE ZINC-PLATED	100817-1	1
4	BEARING ASSEMBLY, UCP 203 CX	101108	2
5	BOLT, 12/M10x25 12.9 ISO7379	F81003-84	2
6	BOLT, M12x40-8.8-HEX HEAD FULL THREAD ZINC	F81004-4	4
7	BOLT, M16d1f6 x120-8.8-SHOULDER ZINC	F81006-34	1
8	NUT, M10-8-B -HEX NYLON ZINC LOCK	F81033-1	2
9	NUT, M12-8 HEX NYLON ZINC LOCK	F81034-2	4
10	NUT, M16-8-HEX NYLON ZINC LOCK	F81036-2	1
11	WASHER, 10,5 FLAT ZINC	F81055-1	2
12	WASHER, 13 FLAT ZINC	F81056-1	12
13	WASHER, 17 FLAT ZINC	F81058-1	2

7.14 Clamp and Coolant Wiper

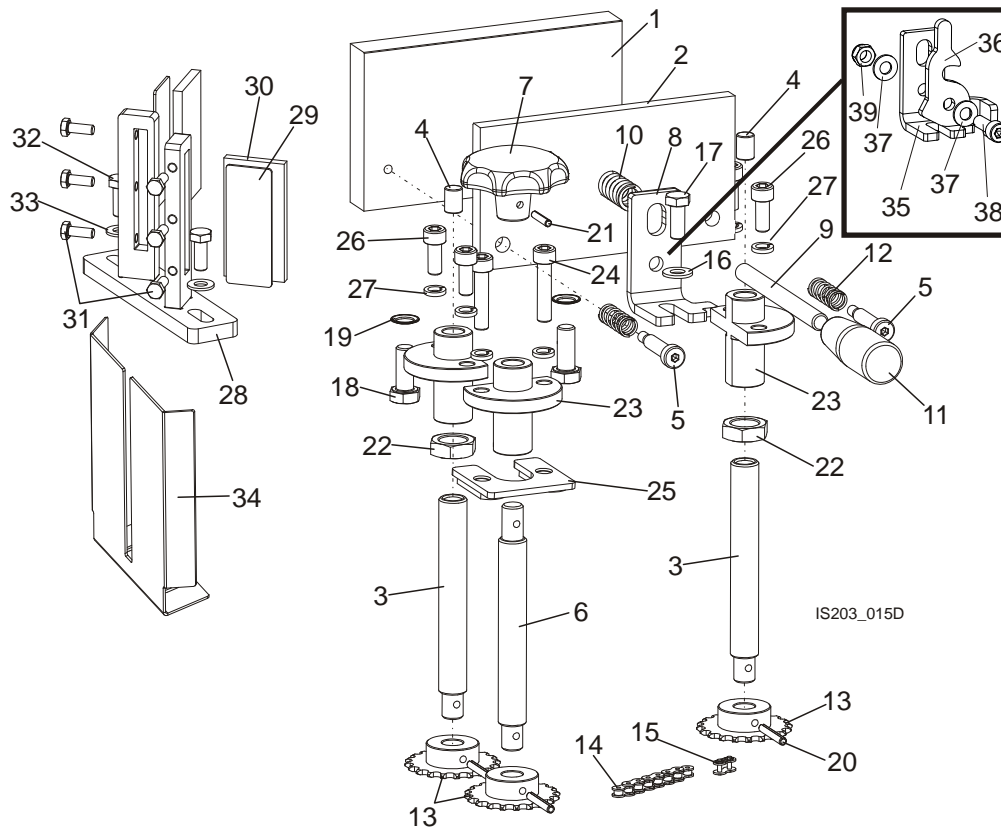

REF.	DESCRIPTION (◆ Indicates Parts Available In Assemblies Only)	PART #.	QTY.
	CLAMP ASSEMBLY WITH HEIGHT ADJUSTMENT, COMPLETE BMS500	101225	1
	CLAMP ASSEMBLY WITH HEIGHT ADJUSTMENT, COMPLETE BMS600	101225-RS	1
1	PLATE, FIXED CLAMP, ZINC	101229-1	1
2	PLATE, MOVING CLAMP, ZINC	101228-1	1
3	SCREW, BLADE HEIGHT ADJUSTMENT COMPLETE	101226-1	2
4	ROLLER, Ø10x14 CYLINDRICAL	096864	2
5	BOLT, 8/M6x30-12.9 ISO-7379	F81001-18	2
6	SCREW, BLADE HEIGHT ADJUSTMENT DRIVING ZINC	101227-1	1
7	KNOB, DIN6336-GG-63-B12-C BLADE HEIGHT ADJUSTMENT	098514	1
8	BRACKET, BLADE CLAMP SPRING	097069-1 ¹	1
9	STUD-BOLT, 1M10X90-8.8-ZINC	F81003-85	1
10	SPRING, BLADE PUSHER	087376	1
11	GRIP, THREAD M10 13870M10	089445	1
12	SPRING, 9x30x1.2 COMPRESSION	088368	2
13	SPROCKET, 05B-1 Z20 8X3-12H7, ZINC-PLATED	098513-1	3
	CHAIN, BLADE HEIGHT ADJUSTMENT - COMPLETE	098515	1
14	CHAIN, 05B-1-73 DRIVING	098516	1
15	LINK, QRC05B-1 MASTER	098517	1
16	WASHER, 8,4-FLAT ZINC	F81054-1	1
17	BOLT, M8x20-8.8-B-HEX HEAD FULL THREAD ZINC	F81002-4	1

7 REPLACEMENT PARTS

Clamp and Coolant Wiper

18	BOLT, M10x25-8.8-HEX HEAD FULL THREAD ZINC	F81003-11	2	
19	WASHER, 791 M10/10.5 RIBBED LOCK	F81055-7	2	
20	PIN, 4x30 SPRING-TYPE STRAIGHT ZINC-PLATE	F81044-7	3	
21	PIN, PN-EN ISO8752-4X20 ST AOP ROLL	F81044-11	1	
22	NUT, M16x1,5-08-B-ZINC HEX THIN	F81036-6	2	
23	NUT, BLADE HEIGHT ADJUSTMENT	101254	3	
24	BOLT, M8x30-8.8 SOCKET HEAD	F81002-31	2	
25	NUT, M8 DOUBLE ZINC	503102-1	1	
26	BOLT, M8 X 20-8.8 SOCKET HEAD	F81002-30	4	
27	WASHER 8,2 SPLIT ZINC	F81054-4	6	
	COMPLETE BLADE WIPER	101230	1	
28	BRACKET, BLADE WIPER MOUNT	101231-1	1	
29	BRACE, BLADE WIPER ZINC-PLATED	101233-1	2	
30	WIPER, BLADE	101234	2	
31	BOLT, M6x16 8.8 HEX HEAD FULL THREAD ZINC	F81001-15	6	
32	BOLT, M8x20-8.8-HEX HEAD FULL THREAD ZINC	F81002-4	2	
33	WASHER, 8,4-FLAT ZINC	F81054-1	2	
34	COVER OIL PAINTED	505978-1²	1	
	BRACKET, BLADE CLAMP SPRING SHARPENER COMPLETE	508842³	1	
35	BRACKET, BLADE CLAMP SPRING	097069-1	1	
36	TRIGGER, BLADE CLAMP SPRING	508841-1	1	
37	WASHER, 8.4 FLAT,ZINC	F81054-1	2	
38	SCREW,M8x25-8.8 HEX SOCKET HEAD CAP ZINC	F81002-21	2	
39	NUT, M8-8-B HEX NYLON ZINC LOCK	F81032-2	1	

¹ Element belongs to 101225

² Element is available only in BMS600 Sharpener

³ Element is available only in BMS600 Sharpener

7 REPLACEMENT PARTS

Deburr Assembly

16	BOLT, M5x15 BN1006 (BOSSARD) TURNED EYE	F81000-30	1	
17	NUT, M5-8-HEX ZINC	F81030-1	1	
18	WASHER, 10,5 FLAT ZINC	F81055-1	6	
19	BOLT, M10x25-8.8-HEX HEAD FULL THREAD ZINC	F81003-11	2	
20	NUT, M10-8-B -HEX NYLON ZINC LOCK	F81033-1	3	
21	SPRING, 1,6x12x38 EXTENSION	092208	1	
22	RING, Z10 OUTSIDE RETAINING	F81090-13	1	
23	BRACKET, PIVOT ARM ZINC-PLATED	101255-1	1	
24	PLUG, SR1086 NA OT.22,2	093544	1	
25	WASHER, 6,4 FLAT ZINC	F81053-1	2	
26	SHAFT, BEARING ZINC-PLATED	500459-1	1	
27	BEARING, 6000 2RSR	087471	4	

7.16 Magnetic Filter

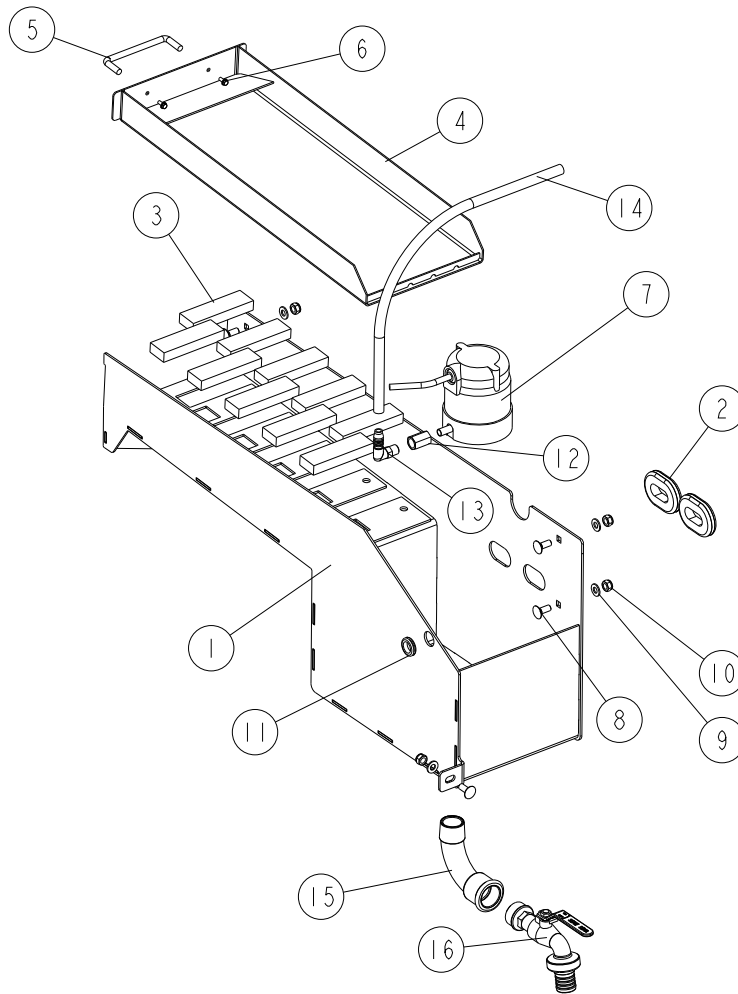

IS203_016_A
100780_Manual

REF.	DESCRIPTION (◆ Indicates Parts Available In Assemblies Only)	PART #.	QTY.
	FILTER, MAGNETIC SHARPENER BMS500, COMPLETE	101269	1
1	TANK, MAGNETIC FILTER	101270-1	1
2	SEAL RUBBER, WIRE INSIDE DIA 26MM	085613	2
3	MAGNET, FILTER 100X30X15	516192	10
	PAN, SHARPENER FILTER BMS500/600, COMPLETE	101249	1
4	PAN, SHARPENER FILTER BMS500/600, WELDED	101251	1
5	HANDLE, 4" W/BOLTS	P08065	1
6	BOLT, #8-32X3/8 SELF TAP	F05015-8	2
7	PUMP, AUTO SHARPENER COOLANT	P09836	1
8	BOLT, M8 X 20 FE/ZN5, PN-M/82406	F81002-11	5
9	WASHER, 8.4 FLAT ZINC	F81054-1	5
10	NUT, M8-8-B HEX NYLON ZINC LOCK	F81032-2	5
11	GROMMET, 5/8 ID RUBBER	P11764	1
12	FITTING, 1/4 F.TH./1/4 F.TH.893-302-	090808	1
13	FITTING WES 10/R 1/4 ELBOW	088379	1
14	HOSE, COOLANT MAGNETIC FILTER	500466	1



REPLACEMENT PARTS

Magnetic Filter

REF.	DESCRIPTION (◆ Indicates Parts Available In Assemblies Only)	PART #.	QTY.	
15	TUBE 90\$ Z GW BSP/GZ BSPT 1", OCYNK, (EE-1/13-16 TUBES).	517294	1	
16	VALVE, BALL, SENA PN 25 RHGC3.	517293	1	

7.17 Magnetic Filter (Sharpener BMS600)

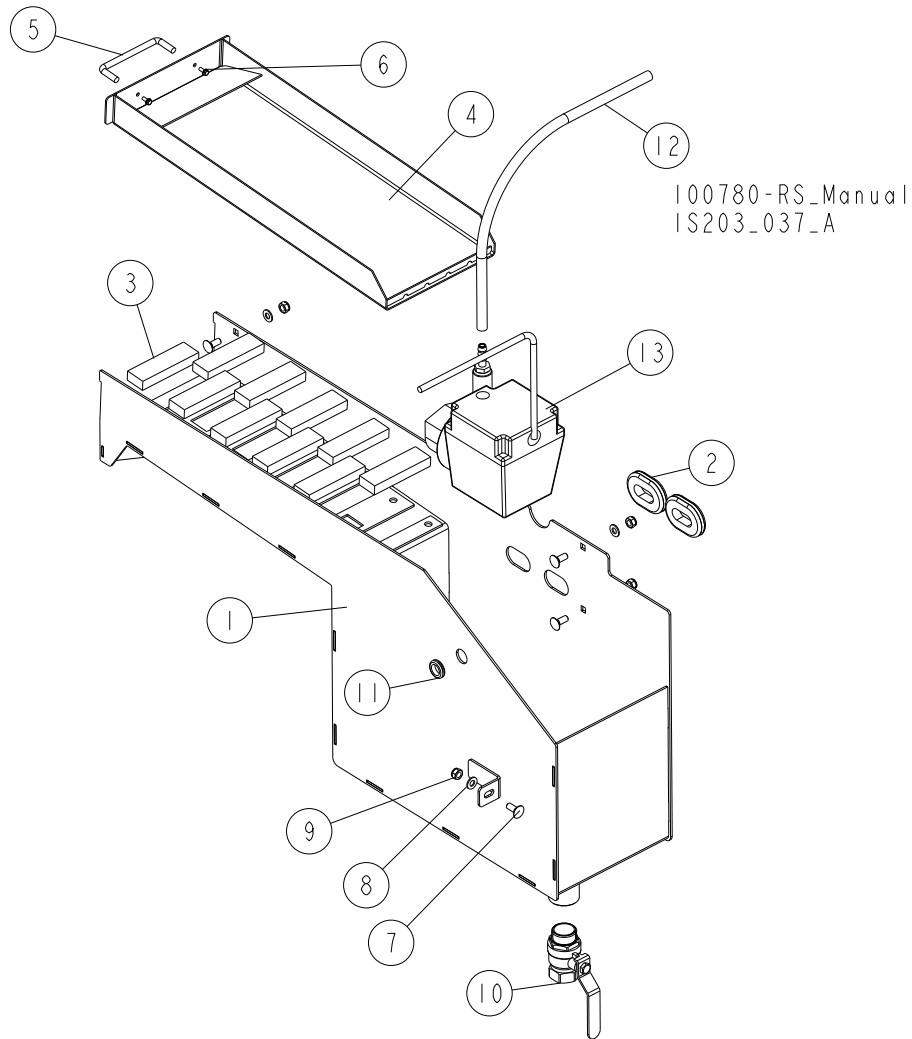

REF.	DESCRIPTION (◆ Indicates Parts Available In Assemblies Only)	PART #.	QTY.
	FILTER, MAGNETIC SHARPENER BMS600, COMPLETE	101269-RS	1
1	TANK, MAGNETIC FILTER	505665-1	1
2	SEAL RUBBER, WIRE INSIDE DIA 26MM	085613	2
3	MAGNET, FILTER 1 00X30X15	516192	10
	PAN, SHARPENER FILTER BMS500/600, COMPLETE	101249	1
4	PAN, SHARPENER FILTER BMS500/600, WELDED	101251	1
5	HANDLE, 4" W/BOLTS	P08065	1
6	BOLT, #8-32X3/8 SELF TAP	F05015-8	2
7	BOLT, M8 X 20 FE/ZN5, PN-M/82406	F81002-11	5
8	WASHER, 8.4 FLAT ZINC	F81054-1	5
9	NUT, M8-8-B HEX NYLON ZINC LOCK	F81032-2	5
10	BALL VALVE 1" WZ SENNA RH018	506596	1
11	GROMMET, 5/8 ID RUBBER	P11764	1
12	HOSE, COOLANT MAGNETIC FILTER	500466	1
13	PUMP ASSY, INDUSTRIAL SHARPENER OIL	030346	1

7.18 Alignment Tool&Blade ProfileTemplate

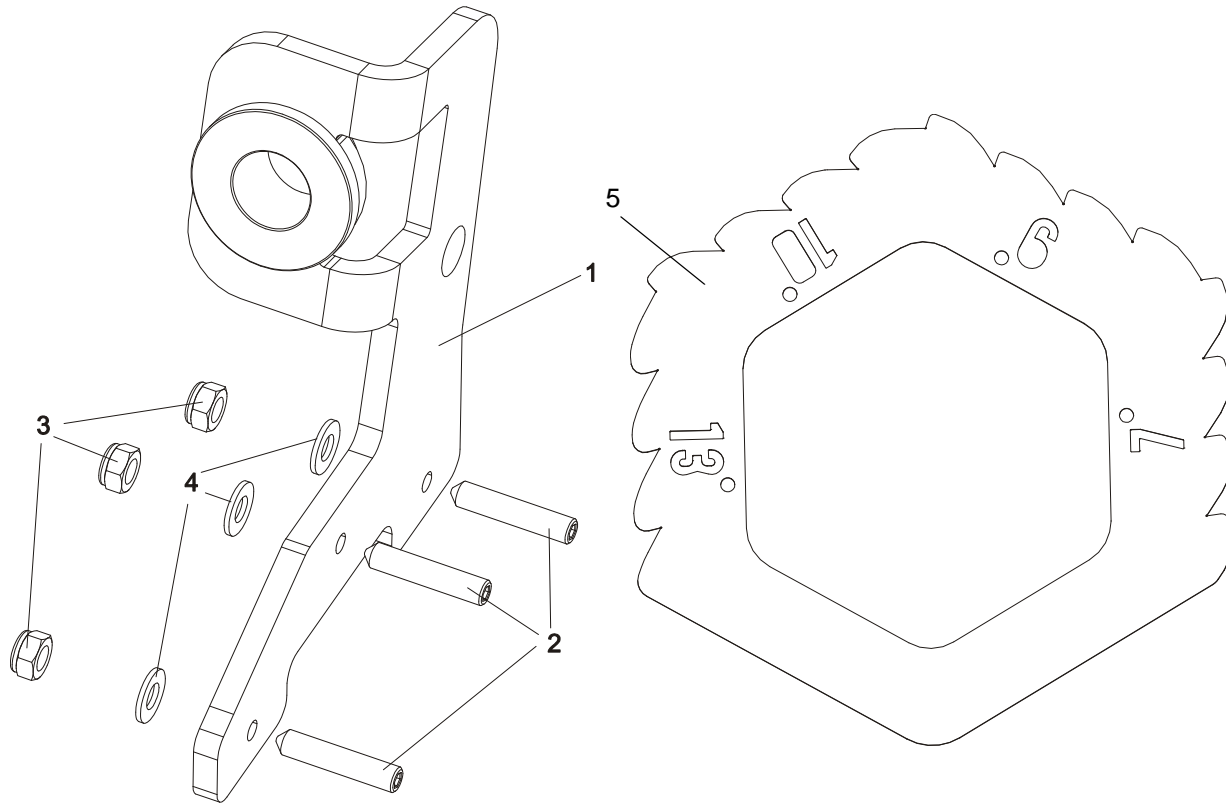

REF.	DESCRIPTION (◆ Indicates Parts Available In Assemblies Only)	PART #.	QTY.	
	ALIGNMENT TOOL, SHARPENER BMS500/600	505190	1	
1	BODY, ALIGNMENT TOOL BMS500/600, ZINC-PLATED	504890-1	1	
2	SCREW,M8x40-45H HEX SOCK.SET CONE POINT	F81002-52	3	
3	NUT, M8-8-B HEX NYLON ZINC LOCK	F81032-2	3	
4	WASHER, 8.4 FLAT ZINC	F81054-1	3	
5	TEMPLATE, BLADE PROFILE	514846-1	3	

7.19 Decal Kit



REF.	DESCRIPTION (◆ Indicates Parts Available In Assemblies Only)	PART #.	QTY.	
	DECAL KIT, SHARPENER BMS500	500467	1	
1	DECAL, SHARPENER BMS500	500801	1	
2	DECAL, GENERAL WARNING	086362	1	
3	DECAL, EYE WARNING, SMALL	S12004G-1	1	
4	DECAL, ELECTRIC POWER SIGN	S10364-P2	1	
5	DECAL, READ OPERATOR'S MANUAL	096317	1	
6	DECAL , SHARPENER COVERS CAUTION	099220	1	
7	DECAL - PICTOGRAM,,OIL"	095961	1	
8	DECAL, CE - CERTIFIED SAWMILL (SMALL)	P85070	1	
	DECAL, SHARPENER ROTATION (7.11 Sharpener Head)	S20097K	1	

7.20 3" Blade Supports Kit (Option)

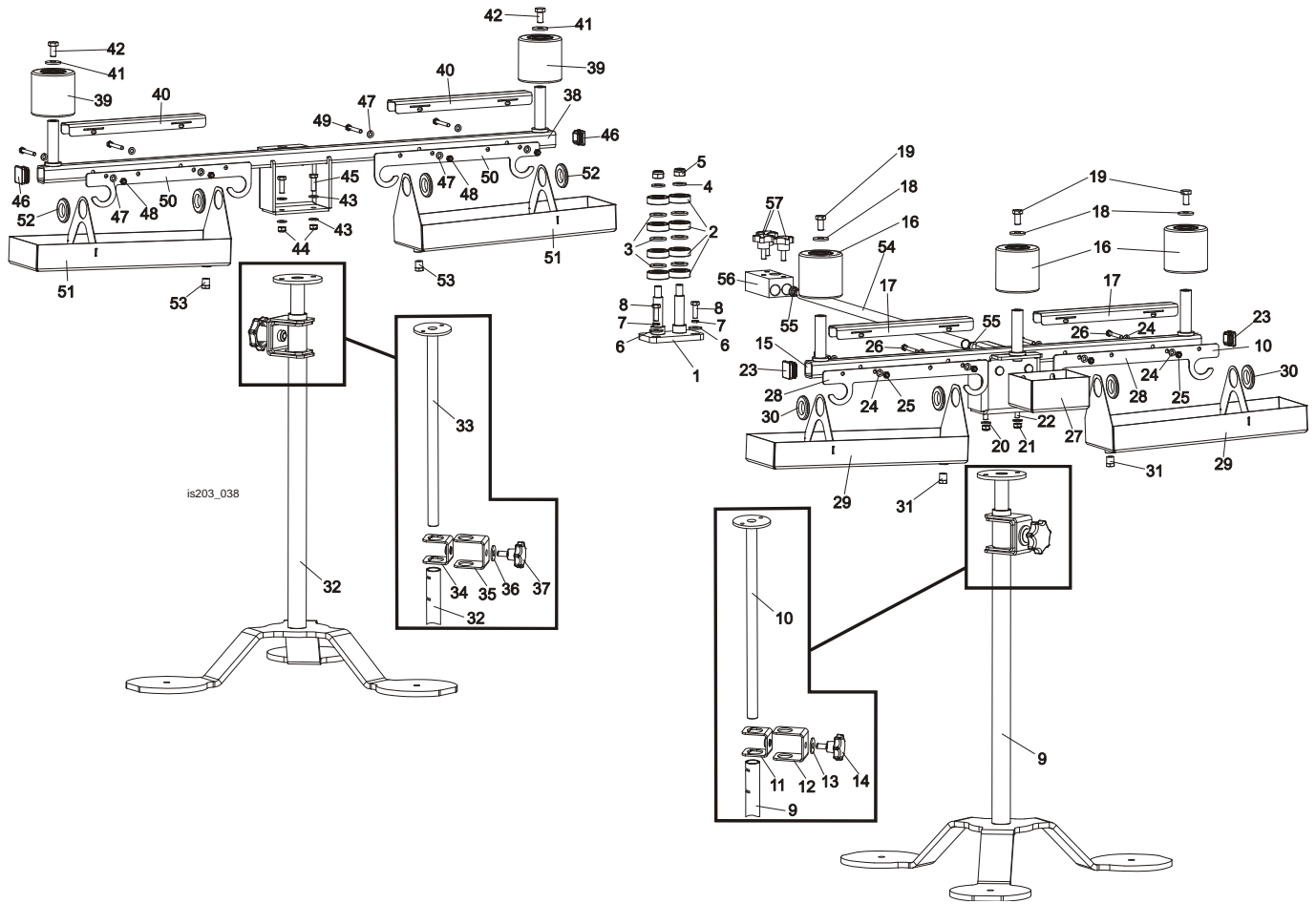

REF.	DESCRIPTION (◆ Indicates Parts Available In Assemblies Only)	PART #.	QTY.
	SUPPORTS KIT, BMS500/600 3" BLADE	505584	1
	GUIDE, 3" BLADE COMPLETE	503790	1
1	PLATE, 3" BLADE GUIDE ZINC-PL.	503791-1	1
2	BEARING, 6203 2RS CX	086114	8
3	WASHER, 17 FLAT ZINC	F81058-1	6
4	WASHER, 13 FLAT ZINC	F81056-1	2
5	NUT, M12-8 HEX NYLON ZINC LOCK	F81034-2	2
6	WASHER, 8.5 SPECIAL FLAT ZINC	F81054-11	2
7	WASHER, 8.2 SPLIT LOCK ZINC	F81054-4	2
8	BOLT, M8x25-8.8-B HEX HEAD FULL THREAD ZINC	F81002-5	2
	SUPPORT, 3" BLADE COMLETE - ENTRY SIDE	504402	1
	STAND, 690-1100 KP BLADE SUPPORT ADJUSTABLE	504401	1
9	TUBE WLDMT, STAND BASE PTD	504392-1	1
10	TUBE WLDMT, STAND ADJUSTMENT ZINC-PL.	504398-1	1
11	CHANNEL, INNER CLAMPING ZINC-PL.	504394-1	1
12	CHANNEL, STAND OUTER ZINC-PL.	504400-1	1
13	WASHER, 13 SPECIAL FLAT ZINC	F81056-14	1
14	KNOB, 1580 DIA. 63x25 M12	500460	1
	COVER, ENTRY-SIDE BLADE SUPPORT COMPLETE	505568	1

REPLACEMENT PARTS

3" Blade Supports Kit (Option)

7

15	ARM, ENTRY-SIDE BLADE SUPPORT PTD	505571-1	1	
16	ROLLER, R-80-80 W/BEARING	099429	3	
17	COVER, BLADE SUPPORT ARM STAINLESS STEEL	505575	2	
18	WASHER, 10.5 SPECIAL FLAT ZINC	F81055-6	3	
19	BOLT, ISO4017-M10x20-8.8-A2E HEX HEAD	F81003-53	3	
20	WASHER, 8.4 FLAT ZINC	F81054-1	4	
21	NUT, M8-8-B HEX NYLON ZINC LOCK	F81032-2	2	
22	BOLT, M8x25-8.8-B HEX HEAD FULL THREAD ZINC	F81002-5	2	
23	CAP, 30x30x3 1540 DIA.	099463	2	
24	WASHER, 6.4 FLAT ZINC	F81053-1	8	
25	NUT, M6-8-B HEX NYLON ZINC LOCK	F81031-2	4	
26	BOLT, M6x50-8.8 HEX HEAD ZINC	F81001-62	4	
27	PAN, OIL DRIP PTD	505579-1	1	
28	PLATE, OIL DRIP PAN HANGER PTD	505582-1	2	
	PAN, OIL DRIP COMPLETE	505583	2	
29	PAN WLDMT, OIL DRIP PTD	101257-1	1	
30	GROMMET, 1" ID RUBBER	P11765	2	
31	PLUG, B-1/4-KU (BST R 1/4")	087605	1	
	SUPPORT, 3" BLADE COMPLETE - EXIT SIDE	504403	1	
	STAND, 690-1100 KP BLADE SUPPORT ADJUSTABLE	504401	1	
32	TUBE WLDMT, STAND BASE PTD	504392-1	1	
33	TUBE WLDMT, STAND ADJUSTMENT ZINC-PL.	504398-1	1	
34	CHANNEL, INNER CLAMPING ZINC-PL.	504394-1	1	
35	CHANNEL, STAND OUTER ZINC-PL.	504400-1	1	
36	WASHER, 13 SPECIAL FLAT ZINC	F81056-14	1	
37	KNOB, 1580 DIA. 63x25 M12	500460	1	
	COVER, EXIT-SIDE BLADE SUPPORT COMPLETE	505569	1	
38	ARM, EXIT-SIDE BLADE SUPPORT PTD	505566-1	1	
39	ROLLER, R-80-80 W/BEARING	099429	2	
40	COVER, BLADE SUPPORT ARM STAINLESS STEEL	505575	2	
41	WASHER, 10.5 SPECIAL FLAT ZINC	F81055-6	3	
42	BOLT, ISO4017-M10x20-8.8-A2E HEX HEAD	F81003-53	3	
43	WASHER, 8.4 FLAT ZINC	F81054-1	4	
44	NUT, M8-8-B HEX NYLON ZINC LOCK	F81032-2	2	
45	BOLT, M8x25-8.8-B HEX HEAD FULL THREAD ZINC	F81002-5	2	
46	CAP, 30x30x3 1540 DIA.	099463	2	
47	WASHER, 6.4 FLAT ZINC	F81053-1	8	
48	NUT, M6-8-B HEX NYLON ZINC LOCK	F81031-2	4	
49	BOLT, M6x50-8.8 HEX HEAD ZINC	F81001-62	4	
50	PLATE, OIL DRIP PAN HANGER PTD	505582-1	2	
	PAN, OIL DRIP COMPLETE	505583	2	
51	PAN WLDMT, OIL DRIP PTD	101257-1	1	
52	GROMMET, 1" ID RUBBER	P11765	2	
53	PLUG, B-1/4-KU (BST R 1/4")	087605	1	
	TUBE, BLADE SUPPORT SPACER COMPLETE	505576	1	
54	TUBE, BMS500/600 SIDE EXTENSION ZINC-PL.	502405-1	1	
55	CAP, 1530 DIA. 18x2	100847	2	
	BLOCK, SPACER TUBE CONNECTION COMPLETE	505577	1	

7**REPLACEMENT PARTS***3" Blade Supports Kit (Option)*

56	BLOCK, SPACER TUBE CONNECTION ZINC-PL.	505578-1	1	
57	HANDWHEEL, 40 DIA./M8x20 (462053 MOSS)	500973	3	

7.21 Table Extensions Kit (BMS600 Option)

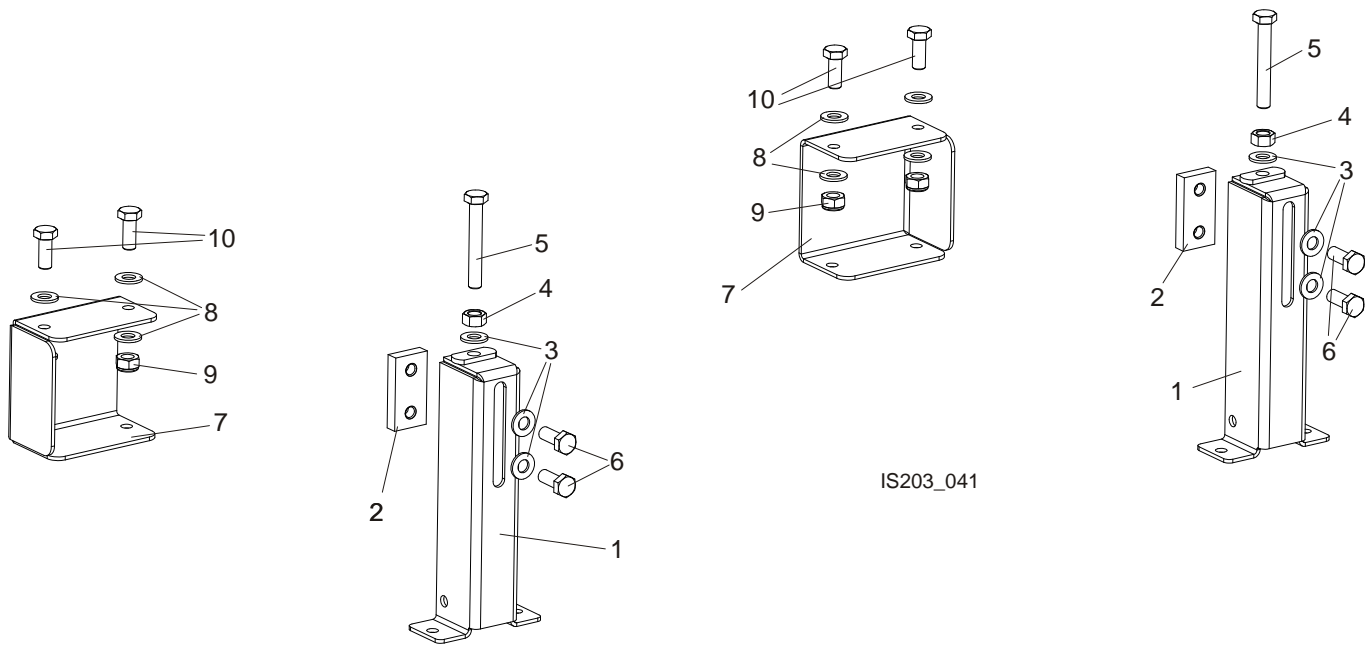

REF.	DESCRIPTION (◆ Indicates Parts Available In Assemblies Only)	PART #.	QTY.
	TABLE EXTENSIONS KIT BMS600 OPTION	508838	1
	ADJUSTABLE LEG HIGH, COMPLETE	508845	2
1	ADJUSTABLE LEG HIGH, PAINTED	508844-1	1
2	PLATE, M10 ZINC	101242-1	1
3	WASHER, 10.5 FLAT ZINC	F81055-1	3
4	NUT, M10-8-B-FE	F81033-3	1
5	BOLT, M10 X 70-8.8 Fe/Zn5, PN-M/82105	F81003-20	1
6	BOLT, M10X25-8.8-FE/ZN5	F81003-11	2
7	FOOT EXTENSION, SHARPENER	508846-1	2
8	WASHER, 10.5 FLAT ZINC	F81055-1	8
9	NUT,M10-8-B NYLON HEX ZINC LOCK	F81033-1	4
10	BOLT, M10X25-8.8-FE/ZN5	F81003-11	4

EC declaration of conformity according to EC Machinery Directive 2006/42/EC

We herewith declare,

Wood-Mizer Industries Sp. z o.o.
114 Nagórna street, 62-600 Koło; Poland.

That the following described machine in our delivered version complies with the appropriate basic safety and health requirements of the EC Machinery Directive 2006/42/EC based on its design and type, as brought into circulation by us. In case of alteration of the machine, not agreed by us, this declaration is no longer valid.

Designation of the machine: **Industrial Sharpener**

TYPE: BMS500, BMS600

No. of manufacturer:

Applicable EC Directives: EC Machinery Directive 2006/42/EC
EC Electromagnetic Compatibility Directive
2004/108/EC

Used harmonized standards: PN-EN 12100:2010
PN-EN 894-1+A1:2010, PN-EN 1037+A1:2010,
PN-EN 894-2+A1:2010, PN-EN 60204-1:2010
PN-EN 894-3+A1:2010, PN-EN 13849-1:2008,
PN-EN 894-4:2010, PN-EN 953+A1:2009,
PN-EN 01310-2:2010, PN-EN 01310-3:2010,
PN-EN 01310-1:2010

Responsible for Technical Documentation: Adam Kubiak / R&D Manager
Wood-Mizer Industries Sp. z o.o.
62-600 Koło, ul. Nagórna 114
Tel. +48 63 26 26 000

Date/Authorized Signature: 05. 11. 2012 **Adam Kubiak**

Title : R&D Manager