

Wood-Mizer®

Parts Manual

LT40L AH

rev. D4.00



Safety is our #1 concern! Read and understand all safety information and instructions before operating, setting up or maintaining this machine.

May 2002

Form #941

Table of Contents

Section-Page

SECTION 1	GENERAL INFORMATION	1-1
1.1	How To Use The Parts List	1-1
1.2	Sample Assembly	1-1
SECTION 2	BLADE GUIDE ROLLERS & ARM	2-1
2.1	Blade Guide Assembly, Idle Side (Standard).....	2-1
2.2	Idle Side Blade Guide Assembly, Optional (LMS).....	2-3
2.3	Blade Guide Assembly, Drive Side.....	2-5
2.4	Blade Guide Arm & Rollers	2-7
2.5	Blade Guide Arm Drive Assembly.....	2-8
SECTION 3	BLADE WHEELS & TENSIONER	3-1
3.1	Blade Drive Assembly, LT40 Series AH	3-1
3.2	Idle Blade Wheel Assembly	3-3
3.3	Hydraulic Blade Tensioner Assembly.....	3-4
SECTION 4	SAW HEAD	4-1
4.1	Middle Throat Screw	4-1
4.2	Water Lube Solenoid Valve	4-1
4.3	Board Return Assembly	4-2
4.4	Water Lube Assembly	4-4
4.5	LT40AC Saw Head Decals	4-6
4.6	Blade Housing Covers.....	4-8
4.7	Drive Belt Covers	4-10
4.8	Sawdust Chute.....	4-11
SECTION 5	CONTROL & BATTERY BOXES	5-1
5.1	Control Assembly, LT40 Series AH	5-1
5.2	Drum Switches	5-3
5.3	Circuit Breakers.....	5-4
SECTION 6	UP/DOWN SYSTEM	6-1
6.1	Saw Head V-Brace Mount.....	6-1
6.2	Blade Height Scale	6-2
6.3	Up/Down Chain & Sprockets.....	6-4
6.4	Up/Down Motor Assembly, LT40 Series AH.....	6-6
6.5	Up/Down Drive Assembly	6-7
SECTION 7	POWER FEED & TRACK ROLLERS	7-1
7.1	Upper Track Rollers And Wipers.....	7-1
7.2	Power Feed Assembly, LT40 Series AH.....	7-2
7.3	Feed Chain/Stop	7-4
7.4	Lower Track Rollers	7-6

Table of Contents

Section-Page

SECTION 8 BED FRAME ASSEMBLY

8-1

8.1	Bed Rail Assembly, Front and Rear	8-1
8.2	Leg, Stationary	8-3
8.3	Pivot Bed Rail Assembly.....	8-4
8.4	Log Side Support Assembly (Manual)	8-5
8.5	Bed Frame Decals.....	8-6
8.6	LT70 L Saw Head Support Assembly.....	8-7
8.7	Tie Down Chain Assembly	8-8

SECTION 9 HYDRAULIC SYSTEM

9-1

9.1	Hydraulic hoses, LT40/70L AH	9-1
9.2	Hydraulic Control Box, LT40/70 AH15/14	9-3
9.3	Hydraulic Control Box	9-5
9.4	Hydraulic Power Supply Strip.....	9-6
9.5	Hydraulic Log Loader	9-7
9.6	Hydraulic Log Turner.....	9-8
9.7	Hydraulic Log Clamp,Front and Rear	9-10
9.8	Hydraulic Log Clamp	9-12
9.9	Hydraulic Toe Board, Middle.....	9-13
9.10	9-14
9.11	Hydraulic Log Side Supports (L Type Frame).....	9-15
9.12	Hydraulic Log Clamp - main.....	9-17
9.13	Hydraulic Toe Board	9-19



SECTION 1 GENERAL INFORMATION

1.1 How To Use The Parts List

- Use the index above to locate the assembly that contains the part you need.
- Go to the appropriate section and locate the part in the illustration.
- Use the number pointing to the part to locate the correct part number and description in the table.
- Parts shown indented under another part are included with that part.
- Parts marked with a diamond (◆) are only available in the assembly listed above the part.

See the sample table below. Sample Part #A01111 includes part F02222-2 and subassembly A03333. Subassembly A03333 includes part S04444-4 and subassembly K05555. The diamond (◆) indicates that S04444-4 is not available except in subassembly A03333. Subassembly K05555 includes parts M06666 and F07777-77. The diamond (◆) indicates M06666 is not available except in subassembly K05555.

1.2 Sample Assembly				
REF	DESCRIPTION (◆ Indicates Parts Available In Assemblies Only)	PART #	QTY.	
	Sample Assembly, Complete (Includes All Indented Parts Below)	A01111	1	
1	Sample Part	F02222-22	1	
	Sample Subassembly (Includes All Indented Parts Below)	A03333	1	
2	Sample Part (◆ Indicates Part Is Only Available With A03333)	S04444-4	1	◆
	Sample Subassembly (Includes All Indented Parts Below)	K05555	1	
3	Sample Part (◆ Indicates Part Is Only Available With K05555)	M06666	2	◆
4	Sample Part	F07777-77	1	

To Order Parts:

- From Europe call our European Headquarters and Manufacturing Facility in Kolo, Poland at **+48-63-2626000**. From the continental U.S., call our toll-free Parts hotline at **1-800-448-7881**. Have your customer number, vehicle identification number, and part numbers ready when you call.
- From other international locations, contact the Wood-Mizer distributor in your area for parts.

SECTION 2 BLADE GUIDE ROLLERS & ARM

2.1 Blade Guide Assembly, Idle Side (Standard)

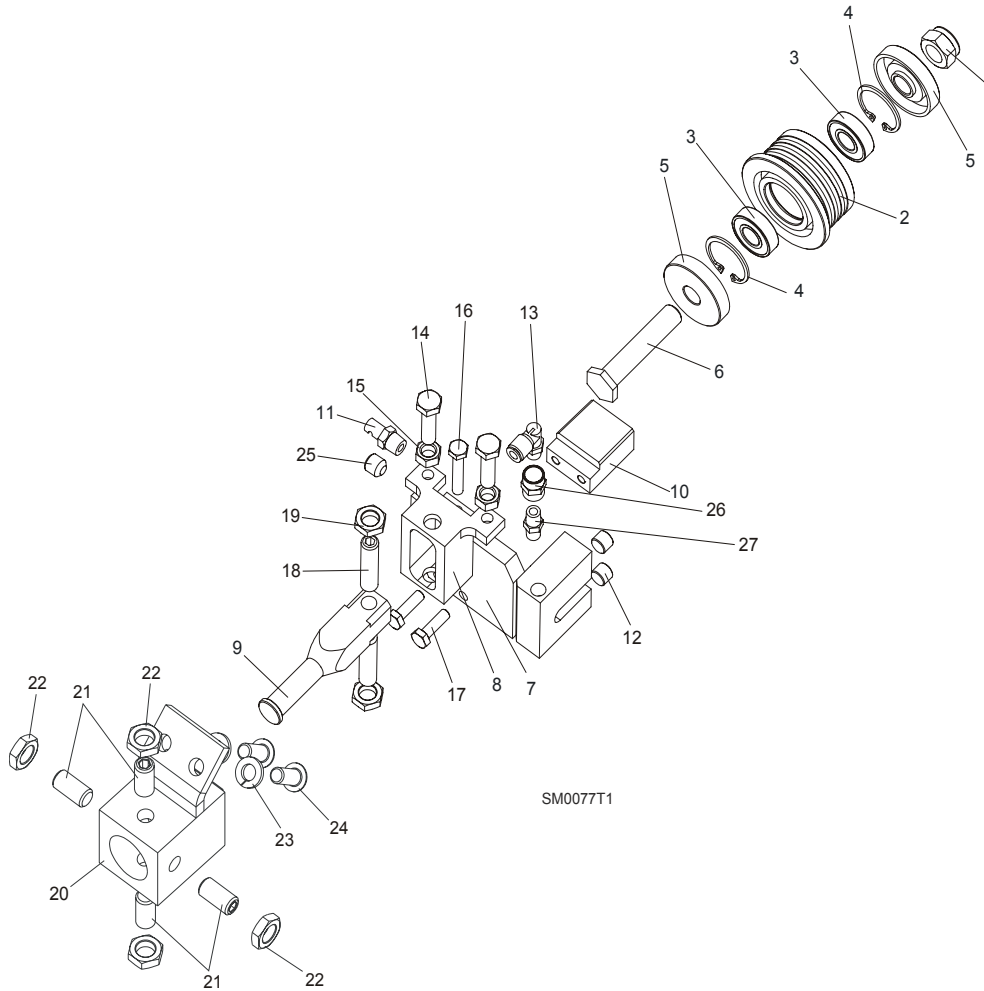

REF	DESCRIPTION (◆ Indicates Parts Available In Assemblies Only)	PART#	QTY.
	BLADE GUIDE ASSEMBLY, IDLE SIDE	092523	1
	Roller, Blade Guide Narrow W/Bearings	088261	1
	Roller, Blade Guide W/Bearings Extended (for optional use with 1 1/2" blades)	092939	1
1	Nut, M12-8 Hex Nylon Zinc Lock	F81034-2	1
2	Roller, Blade Guide Narrow	087889	1
	Roller, Blade Guide Extended (for optional use with 1 1/2" blades)	087890	1
3	Bearing, 6001 2RSR NACHI	087893	2
4	Ring, W28 Inside Retaining	F81090-9	2
5	Washer, Spacer	087891	2 (1)
	Washer, Spacer (used with the Extended Roller only) ¹	087892-1	1
6	Bolt, Blade Guide Roller Zinc-Plated	087761-1	1
	Bolt, Blade Guide Roller Zinc Plated (used with the Extended Roller only)	092940-1	1
7	Block Weldment, Nozzle Zinc-Plated	087750-1	1
8	Block, Zinc-Plated Roller Guide Adjuster	087756-1	1
9	Shaft, Zinc-Plated Blade Guide Mount	088255-1	1

2

Blade Guide Rollers & Arm*Blade Guide Assembly, Idle Side (Standard)*

10	Block, Blade Guide Zinc	096956-1	1	
11	Nozzle, Blade Water Lube Spray	016637	1	
12	Plug, M10x1 DIN 906 BN40 "BOSSARD"	F81015-3	2	
13	Fitting, 90° Elbow 1/8NPT-1/4 Tube Swivel	P09736	1	
14	Bolt, M8x30 DIN933 A2-70 Stainless Steel	F81002-27	2	
15	Nut, M8 DIN934 A2-70 Stainless Steel	F81032-7	2	
16	Bolt, M6x30 DIN933 A2-70 Stainless Steel	F81001-37	1	
17	Bolt, M6x20-8.8 Hex Head Full Thread Zinc	F81001-2	2	
18	Screw, M10x1x40 DIN913 Stainless Steel Set	F81015-2	2	
19	Nut, M10x1-04-ST-A2 ISO 8675 Thin	F81033-10	2	
20	BLOCK WELDMENT, PAINTED BLADE GUIDE MOUNT	088292-1	1	
21	SCREW, M10X1X20 DIN913 STAINLESS STEEL SET	F81015-1	4	
22	NUT, M10x1-04-ST-A2 ISO 8675 THIN	F81033-10	4	
23	WASHER, 8.2 SPLIT LOCK ZINC	F81054-4	2	
24	BOLT, 5/16-18X3/4 SOCKET HEAD	F05006-102	2	
25	FITTING, 1/8 NPT SOCKET PIPE PLUG	P30127	1	
26	FITTING, 1/8FPT COUPLING	P05748	1	
27	NIPPLE, 1/8 DRY SEAL	P02764	1	

¹ Used only from the flanged side of the roller

2.2 Idle Side Blade Guide Assembly, Optional (LMS)

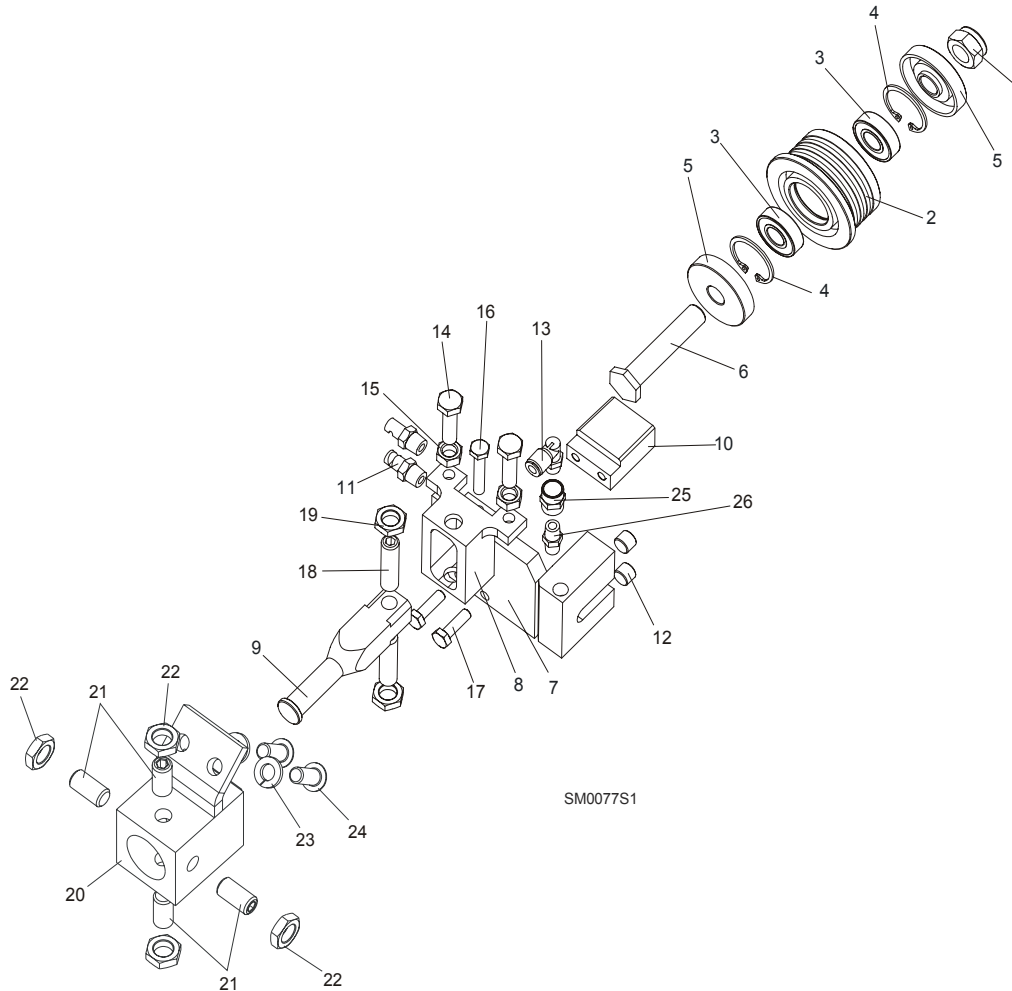

REF	DESCRIPTION (◆ Indicates Parts Available In Assemblies Only)	PART#	QTY.
	BLADE GUIDE ASSEMBLY, IDLE SIDE	087749	1
	Roller, Blade Guide Narrow W/Bearings	088261	1
	Roller, Blade Guide W/Bearings Extended (for optional use with 1 1/2" blades)	092939	1
1	Nut, M12-8 Hex Nylon Zinc Lock	F81034-2	1
2	Roller, Blade Guide Narrow	087889	1
	Roller, Blade Guide Extended (for optional use with 1 1/2" blades)	087890	1
3	Bearing, 6001 2RSR NACHI	087893	2
4	Ring, W28 Inside Retaining	F81090-9	2
5	Washer, Spacer	087891	2 (1)
	Washer, Spacer (used with the Extended Roller only) ¹	087892-1	1
6	Bolt, Blade Guide Roller Zinc-Plated	087761-1	1
	Bolt, Blade Guide Roller Zinc Plated (used with the Extended Roller only)	092940-1	1
7	Block Weldment, Nozzle Zinc-Plated	087750-1	1
8	Block, Zinc-Plated Roller Guide Adjuster	087756-1	1
9	Shaft, Zinc-Plated Blade Guide Mount	088255-1	1
10	Block, Blade Guide Zinc	096956-1	1

2

Blade Guide Rollers & Arm*Idle Side Blade Guide Assembly, Optional (LMS)*

11	Nozzle, Blade Lube Spray	033479	2	
12	Plug, M10x1 DIN 906 BN40 "BOSSARD"	F81015-3	2	
13	Fitting, 90° Elbow 1/8NPT-1/4 Tube Swivel	P09736	1	
14	Bolt, M8x30 DIN933 A2-70 Stainless Steel	F81002-27	2	
15	Nut, M8 DIN934 A2-70 Stainless Steel	F81032-7	2	
16	Bolt, M6x30 DIN933 A2-70 Stainless Steel	F81001-37	1	
17	Bolt, M6x20-8.8 Hex Head Full Thread Zinc	F81001-2	2	
18	Screw, M10x1x40 DIN913 Stainless Steel Set	F81015-2	2	
19	Nut, M10x1-04-ST-A2 ISO 8675 Thin	F81033-10	2	
20	BLOCK WELDMENT, PAINTED BLADE GUIDE MOUNT	088292-1	1	
21	SCREW, M10X1X20 DIN913 STAINLESS STEEL SET	F81015-1	4	
22	NUT, M10x1-04-ST-A2 ISO 8675 THIN	F81033-10	4	
23	WASHER, 8.2 SPLIT LOCK ZINC	F81054-4	2	
24	BOLT, 5/16-18X3/4 SOCKET HEAD	F05006-102	2	
25	FITTING, 1/8FPT COUPLING	P05748	1	
26	NIPPLE, 1/8 DRY SEAL	P02764	1	

¹ Used only from the flanged side of the roller

2.3 Blade Guide Assembly, Drive Side

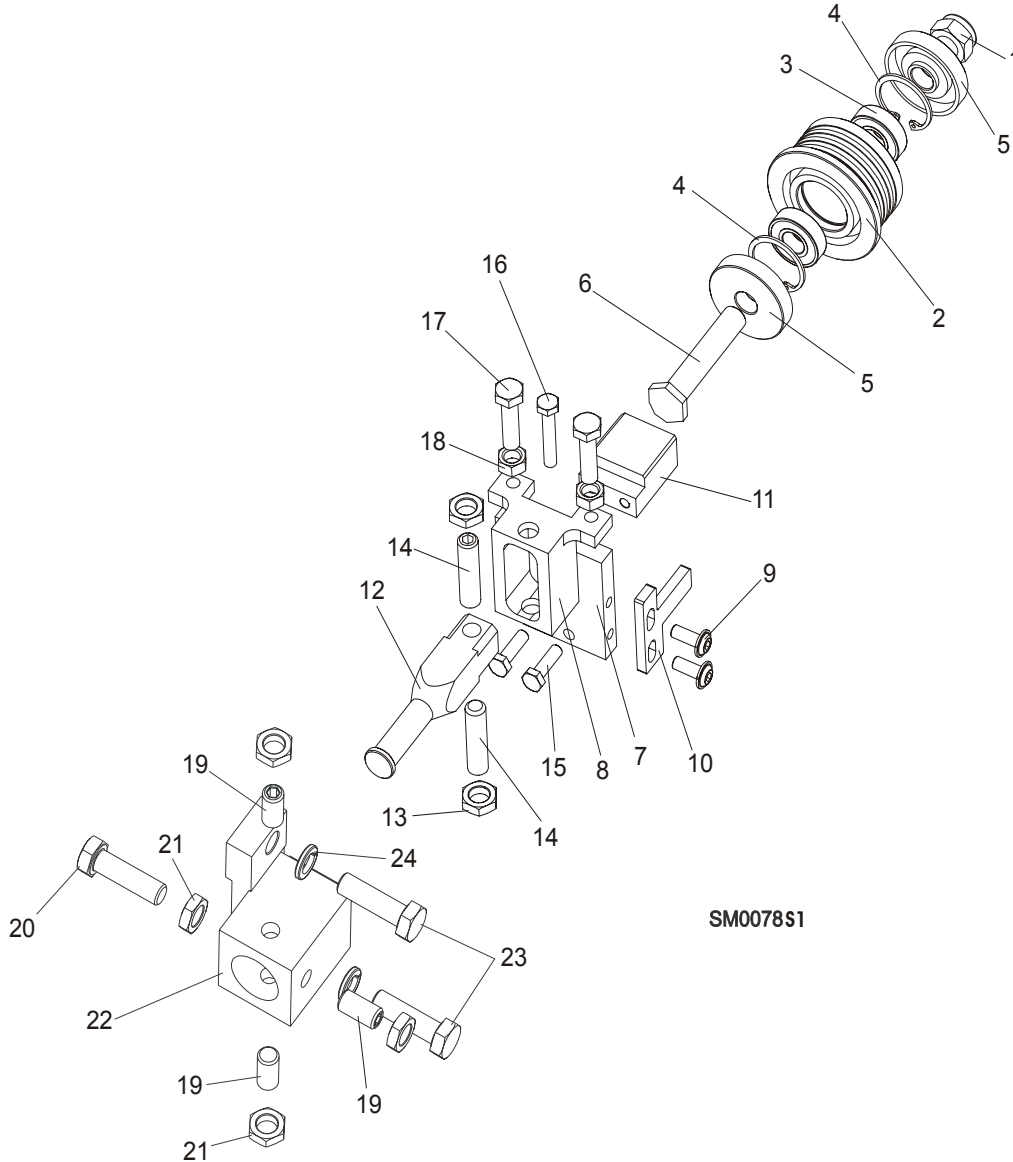

REF	DESCRIPTION (◆ Indicates Parts Available In Assemblies Only)	PART#	QTY.
	BLADE GUIDE ASSEMBLY, DRIVE SIDE	087748	1
	Roller, Blade Guide Narrow W/Bearings	088261	1
	Roller, Blade Guide W/Bearings Extended (for optional use with 1 1/2" blades)	092939	1
1	Nut, M12-8 Hex Nylon Zinc Lock	F81034-2	1
2	Roller, Blade Guide Narrow	087889	1
	Roller, Blade Guide Extended (for optional use with 1 1/2" blades)	087890	1
3	Bearing, 6001 2RSR NACHI	087893	2
4	Ring, W28 Inside Retaining	F81090-9	1
5	Washer, Spacer	087891	2 (1)
	Washer, Spacer (used with the Extended Roller only) ¹	087892-1	1

2

Blade Guide Rollers & Arm*Blade Guide Assembly, Drive Side*

6	Bolt, Blade Guide Roller Zinc-Plated	087761-1	1	
	Bolt, Blade Guide Roller Zinc Plated (used with the Extended Roller only)	092940-1	1	
7	Plate, Zinc-Plated Blade Guide Mounting	087753-1	1	
8	Block, Zinc-Plated Roller Guide Adjuster	087756-1	1	
9	Screw, M6x16 BN 11252 "BOSSARD"	F81001-24	2	
10	Wiper, Blade Zinc-Plated	087757-1	1	
11	Block, Blade Guide Zinc	096956-1	1	
12	Shaft, Zinc-Plated Blade Guide Mount	088255-1	1	
13	Nut, M10x1-04-ST-A2 ISO 8675 Thin	F81033-10	2	
14	Screw, M10x1x40 DIN913 Stainless Steel Set	F81015-2	2	
15	Bolt, M6x20-8.8 Hex Head Full Thread Zinc	F81001-2	2	
16	Bolt, M6x30 DIN933 A2-70 Stainless Steel	F81001-37	1	
17	Bolt, M8x30 DIN933 A2-70 Stainless Steel	F81002-27	2	
18	Nut, M8 DIN934 A2-70 Stainless Steel	F81032-7	2	
19	Screw, M10X1X20 DIN913 Stainless Steel Set	F81015-1	3	
20	BOLT, M10X1X25 DIN 933 STAINLESS STEEL	F81003-28	1	
21	NUT, M10x1-04-ST-A2 ISO 8675 THIN	F81033-10	4	
22	BLOCK WELDMENT, BLADE GUIDE MOUNT	087744	1	
23	BOLT, M10X35-8.8 HEX HEAD FULL THREAD ZINC	F81003-17	2	
24	WASHER, 10.2 SPLIT LOCK ZINC	F81055-2	2	

¹ Used only from the flanged side of the roller

2.4 Blade Guide Arm & Rollers

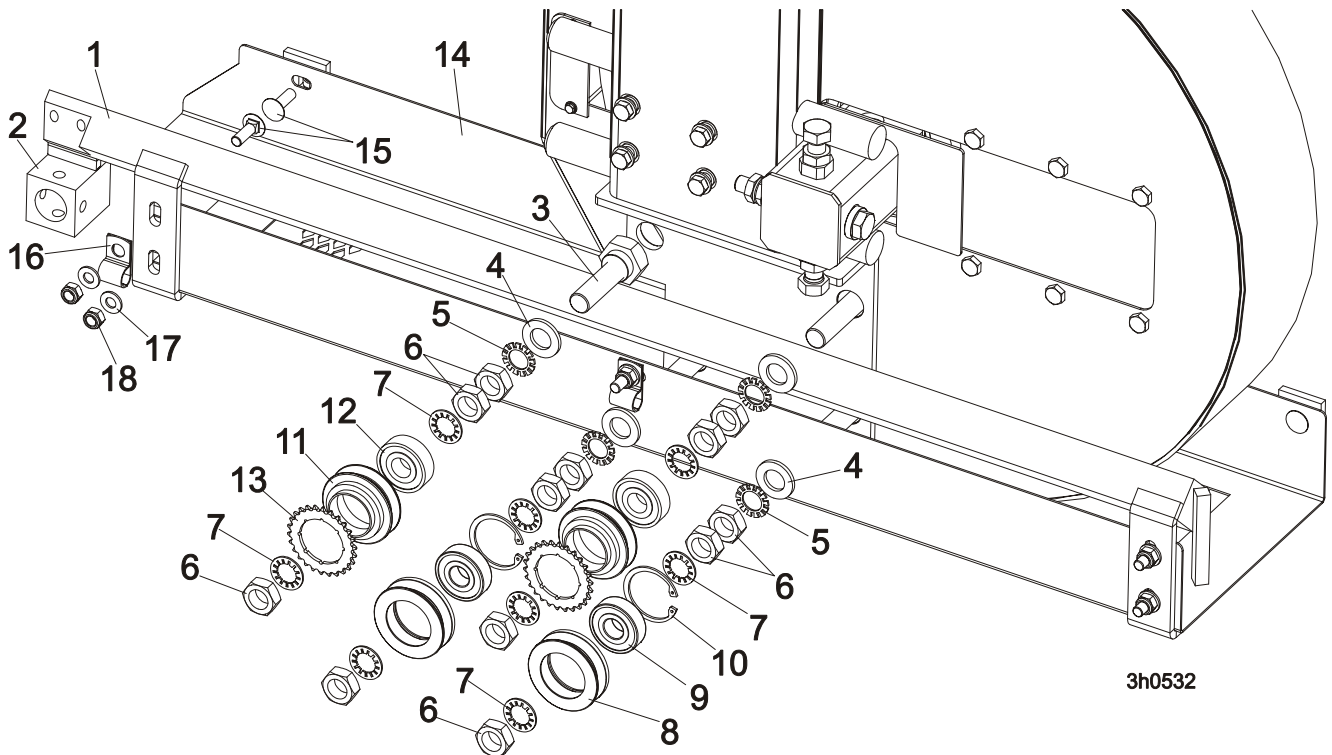

REF	DESCRIPTION (◆ Indicates Parts Available In Assemblies Only)	PART #	QTY.	
1	BLADE GUIDE ARM WELDMENT	087018-1	1	
2	BLOCK WELDMENT, PAINTED BLADE GUIDE MOUNT	088292-1	1	
3	BOLT, BLADE GUIDE ARM ROLLER CAM	086508-1	4	
4	WASHER, 17 FLAT	F81058-1	4	
5	WASHER, 5/8" EXTERNAL STAR	F05011-26	4	
6	NUT, 5/8-18 HEX JAM	F05010-11	12	
7	WASHER, 5/8" INTERNAL STAR	F05011-25	8	
	ROLLER ASSEMBLY, BLADE GUIDE ARM WITH BEARING	093855	2	
8	Roller, Blade Guide Arm V-Groove	093856-1	1	◆
9	Bearing, 6203-2RSP6-5/8 CX	095087	1	
10	Ring, W40 Retaining	F81090-3	1	
	ROLLER ASSEMBLY, BLADE GUIDE ARM WITH BEARING AND SPROCKET	A09932	2	
11	Roller, Blade Guide Arm Drive	S09930	1	◆
12	Bearing, 6203-2RSP6-5/8 CX	095087	1	
13	Sprocket, #25 26-Tooth	015939	1	◆
14	GUIDE, BLADE	087042-1	1	
15	BOLT, M8x20-8.8 Fe/Zn5 PN-M/82406	F81002-11	7	
16	CLAMP, 1/2EMT COATED	P07584	2	
17	WASHER, 8.4 FLAT ZINC	F81054-1	7	
18	NUT, M8-8-B HEX NYLON ZINC LOCK	F81032-2	7	

2.5 Blade Guide Arm Drive Assembly

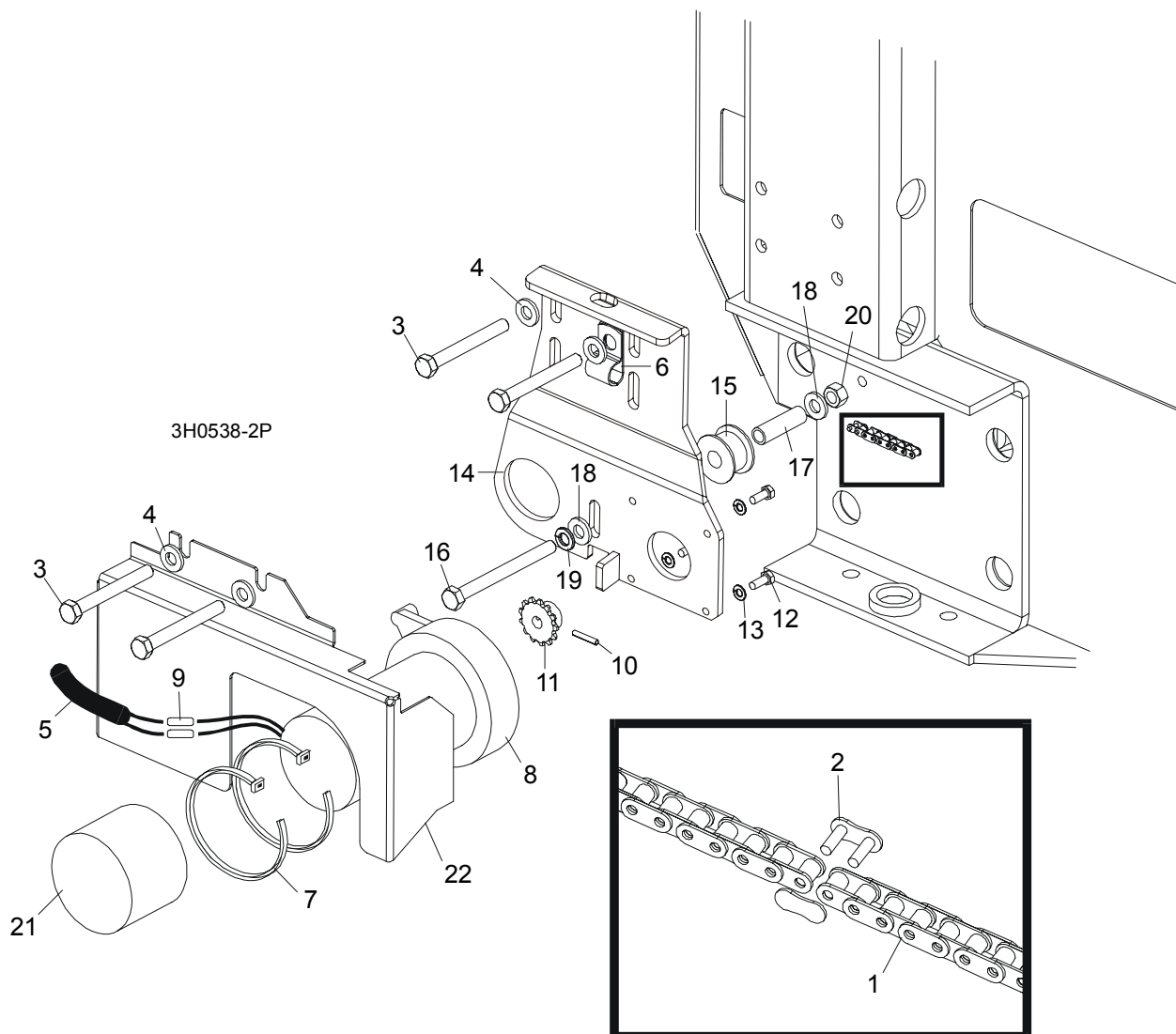

REF	DESCRIPTION (◆ Indicates Parts Available In Assemblies Only)	PART #	QTY.
1	CHAIN, #25 X 20 1/4"	P09984	1
2	LINK, #25 MASTER	P09983	1
3	BOLT, 5/16-18 X 2 3/4" HEX HEAD GRADE 5	F05006-28	4
4	WASHER, 8.4 FLAT	F81054-1	4
5	TUBE, 3/8" X 1/2" NEOPRENE	R01897	0,75 m
6	CLAMP, 1/2" COATED EMT	P07584	2
7	WRAP, 1/4" X 6" TIE	F05089-1	2
	DRIVE ASSEMBLY, BLADE GUIDE ARM	091005	1
	Motor Assembly, Blade Guide Arm Replacement	A10365	1
8	Motor, Blade Guide Arm 53:1 Gear	P09698-1	1
	Housing, Klauber Motor End	P12756	1
	Gear Kit, Klauber Motor Replacement	P12569	1
	Brush Kit, Gear Motor Replacement	P12800	1

	Shaft Kit, Klauber Gear Motor Replacement	009695	1	
9	Connector, 14 Gauge Butt	F04875-1	2	
10	Pin, 1/8" X 3/4" Roll	F05012-6	1	
11	Sprocket, Gear Motor #25 14-Tooth	P09970	1	
12	Screw, #10-32 x 1/2" Hex Head	F05004-60	4	
13	Washer, 4.1 Split Lock	F81051-4	4	
	Instruction Sheet, Blade Guide Arm Motor	A10353-296	1	
14	Bracket, Blade Guide Arm Motor Mount	087994-1	1	
15	Roller, Blade Guide Arm Chain Idler	S09999	1	
16	Bolt, 5/16-18 X 3 1/2" Hex Head Full Thread	F05006-3	1	
17	Spacer, 5/16" I.D. X 1 1/2"	S09996	1	
18	Washer, 5/16" SAE Flat	F81054-1	2	
19	Washer, 8.4 Split Lock	F05011-13	1	
20	Nut, 8.2 Hex Lock	F81054-4	1	
21	Boot, Gear Motor Weather	023720	1	
22	COVER, BLADE GUIDE ARM MOTOR	093460-1	1	

SECTION 3 BLADE WHEELS & TENSIONER

3.1 Blade Drive Assembly, LT40 Series AH

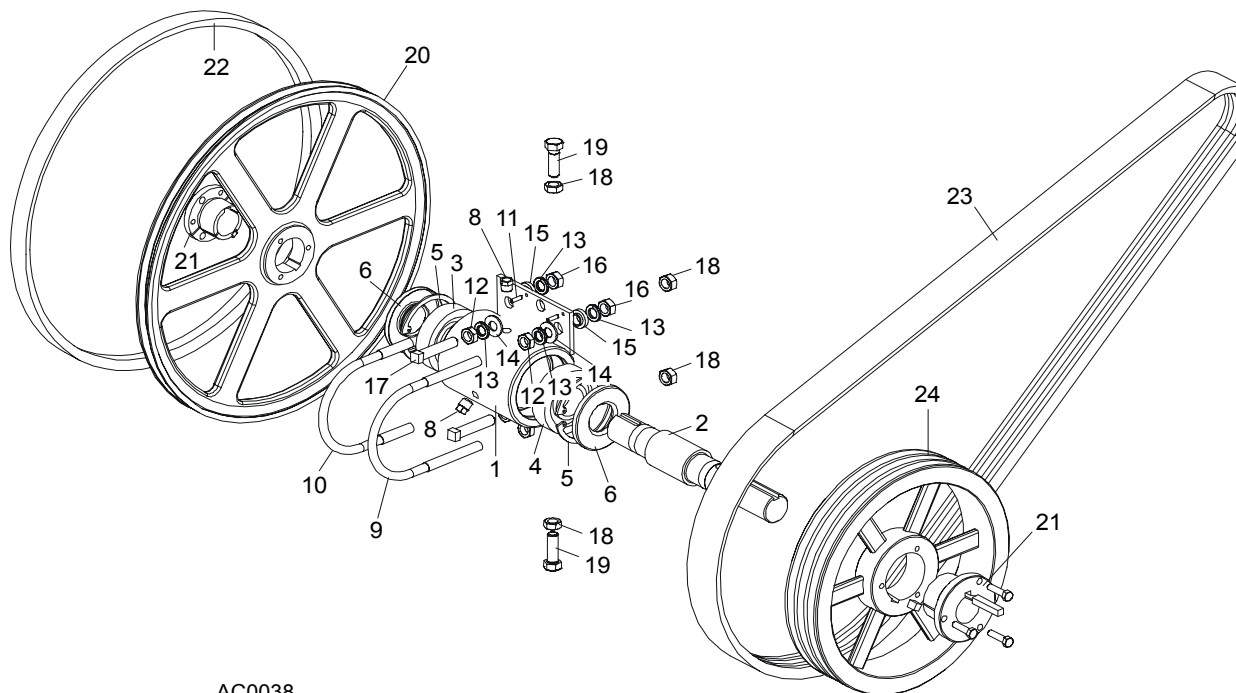

AC0038

REF	DESCRIPTION (◆ Indicates Parts Available In Assemblies Only)	PART #	QTY.
	BEARING ASSEMBLY, BLADE WHEEL DRIVE	086291	1
1	Housing, Blade Wheel Drive Bearing	086293	1
2	Shaft, Blade Wheel Drive	086292	1
3	Bearing, Blade Wheel Drive NJ308	085939	1
4	Bearing, Blade Wheel Drive #6308	085940	1
5	Ring, 90mm Interior Retaining #117	F04254-17	2
6	Seal, Drive Bearing #CR15890	P10206	2
7	Plug, 1/4" NPT Square Head	P05498	1
8	Plug, 1/4" NPT Vented	P12868	1
9	Bolt, 1/2-13 Long U	S10207-1P	1
10	Bolt, 1/2-13 Short U	S10207-2P	1
11	Pin, 3/16" X 5/8" Roll	F05012-22	2
12	Nut, 1/2-20 Hex Jam	F05010-16	4
13	Washer, 12.2 Split Lock	F81056-2	8
14	Washer, 13 SAE Flat	F81056-1	4
15	Spacer, .510" x .937" x .34"	S04253	4
16	Nut, 1/2-13 Hex	F05010-35	4
17	Screw, 1/2-20 x 2 1/2" Square Head Full Thread Set	F05008-110	2
18	Nut, M12-8 Hex Nylon Lock	F81034-2	4
19	Bolt, 1/2-20 x 1 1/2" Hex Head Grade 5	F05008-53	2
	Decal, Bearing End-Play	S12750	1

	Instruction Sheet, Bearing Retrofit	K10200-275	1	
	WHEEL KIT, DRIVE SIDE BLADE	014562	1	
20	Wheel, Drive Side Blade	016284	1	
21	Bushing, Modified 1 9/16" P1	087214	1	
	Instruction Sheet, Drive Side Blade Wheel Replacement	K12987-488	1	
22	BELT, BLADE WHEEL B57	P04185	1	
23	BELT, 3BX72 DRIVE (EA20, EA25)	014249	1	
24	PULLEY, 3B124 SK SPECIAL (EA20, EA25)	087203-1	1	

3 Blade Wheels & Tensioner

Idle Blade Wheel Assembly

3.2 Idle Blade Wheel Assembly

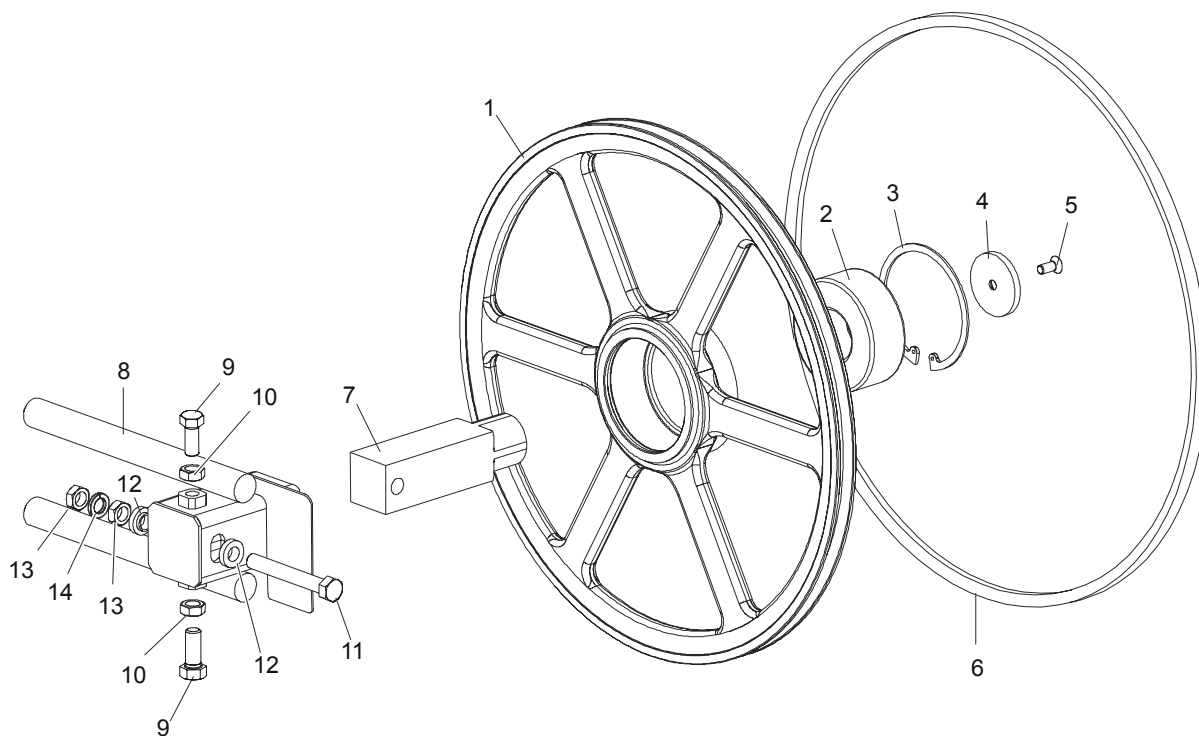

SM0241C

REF	DESCRIPTION (◆ Indicates Parts Available In Assemblies Only)	PART #	QTY.	
	WHEEL ASSEMBLY, IDLE SIDE BLADE	016120	1	
1	Wheel, Idle Side Blade	016013	1	◆
2	Bearing, Idle Side Blade Wheel 3309 B.2RSR TVH FAQ	086428	1	
3	Ring, 100mm Internal Retaining Beveled	F04254-28	1	
4	RETAINER, ZINC	095929-1	1	
5	BOLT, M10x25 -10.9- Fe/Zn5 DIN 7991	F81003-82	1	
6	BELT, BLADE WHEEL B57	P04185	1	
7	SHAFT, IDLE BLADE WHEEL	095732	1	
8	HOUSING, IDLE BLADE WHEEL SHAFT	016103	1	
9	BOLT, 1/2-20 X 1 1/2" HEX HEAD GRADE 5	F05008-53	2	
10	NUT, 1/2-20 HEX JAM	F05010-16	2	
11	BOLT, M12x1,25x100-8.8 HEX HEAD FULL THREAD GRADE 2	F81004-41	1	
12	SPACER, 1/2" I.D. FLANGED	086769-1	2	
13	NUT, M12x1,25 8.8 HEX JAM	F81034-5	2	
14	WASHER, 12.2 SPLIT LOCK	F81056-2	1	

3.3 Hydraulic Blade Tensioner Assembly

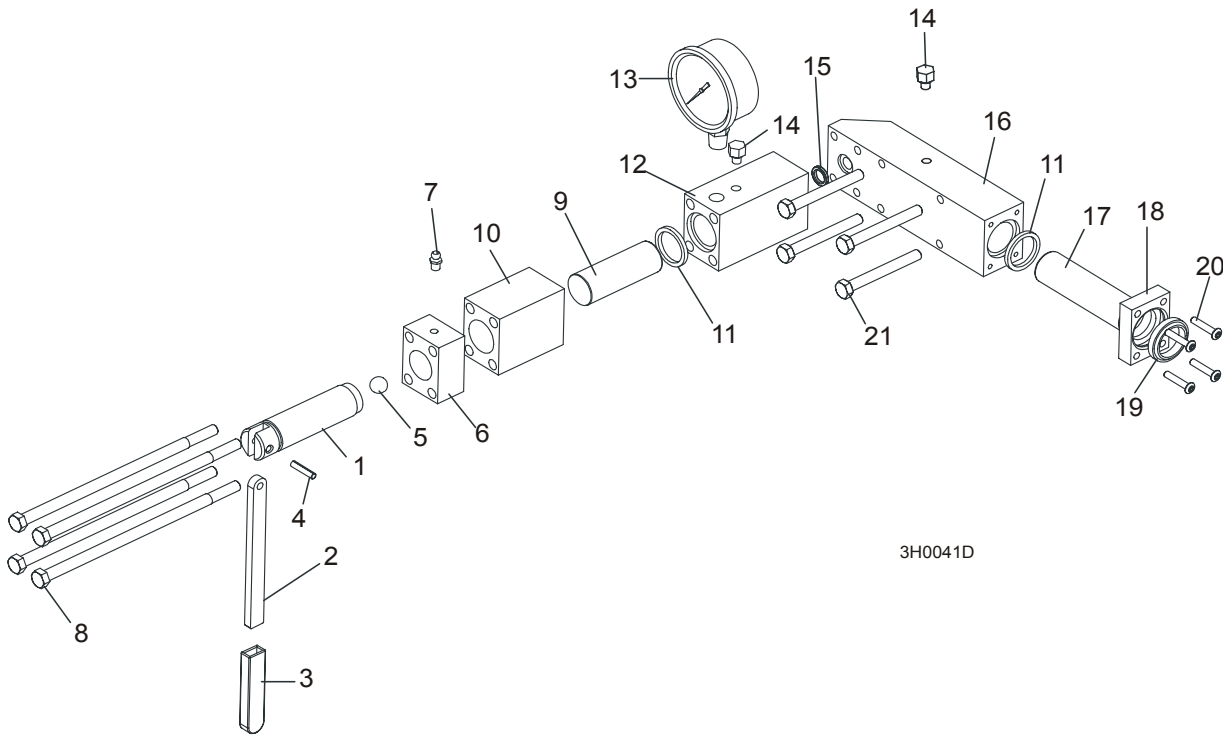

REF	DESCRIPTION (◆ Indicates Parts Available In Assemblies Only)	PART #	QTY.	
	HYDRAULIC BLADE TENSIONER ASSEMBLY	A10054	1	
	Handle Assembly, Hydraulic Blade Tensioner Screw	A12294	1	
1	Screw, Hydraulic Blade Tensioner	S10056	1	
2	Handle, Hydraulic Tensioner Screw	095930	1	
3	Sleeve, Plastic Handle	P08072	1	
4	Pin, 3/16" x 7/8" Roll	F05012-19	1	
5	Ball, 1/2" Steel	P02720	1	
6	Block, Threaded Tensioner End	S10062	1	
7	Fitting, 1/4-28 Grease	P05060	1	
	Instruction Sheet, Tensioner Screw	A12294-518	1	
8	Bolt, 5/16-18 X 7 1/2" Hex Head Grade 5	F05006-43	4	
9	Piston, Hydraulic Tensioner Front 2 3/4" Long	S10060	1	
10	Block, Piston Guide	S10061	1	
11	Seal, 1" Diameter	P10051	2	
12	Block, Hydraulic Tensioner Gauge Mounting	S10140	1	
13	Gauge, 3000 PSI	090552	1	
14	Plug, Hydraulic Tensioner Fill	P10065	1	
15	Ring, 5/8" X 3/32" Square "O"	P10377	1	
16	Block, Rear Tensioner Piston	S10142	1	
17	Piston, Hydraulic Tensioner Rear 3 5/8" Long	S10059	1	
18	Block, Rear Piston End	S10089	1	
19	Wiper, 1" Diameter	P10053	1	
20	Bolt, #10-24 X 1" Socket Button Head	F05004-43	4	
21	Bolt, 5/16-18 X 2 3/4" Hex Head Grade 5	F05006-28	4	
	Instruction Sheet, Hydraulic Tensioner Installation	A10136-272	1	



Blade Wheels & Tensioner

Hydraulic Blade Tensioner Assembly

SECTION 4 SAW HEAD

4.1 Middle Throat Screw

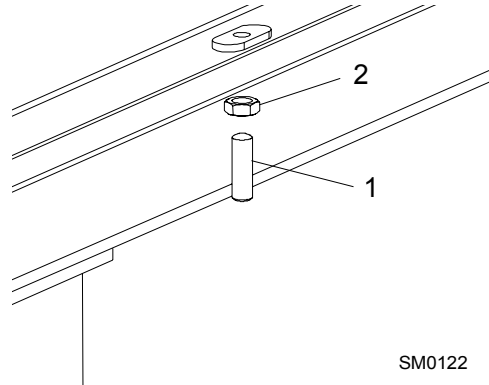

REF	DESCRIPTION (◆ Indicates Parts Available In Assemblies Only)	PART #	QTY.	
1	SCREW, 3/8-16 X 1 1/4" OVAL POINT SOCKET SET	F05007-18	1	
2	NUT, 3/8-16 HEX JAM	F05010-29	1	

4.2 Water Lube Solenoid Valve

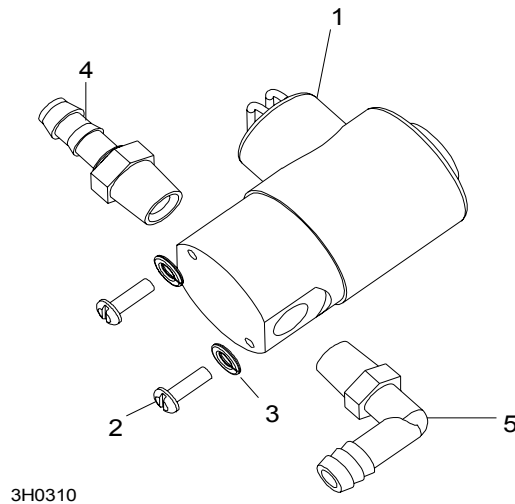

REF	DESCRIPTION (◆ Indicates Parts Available In Assemblies Only)	PART #	QTY.	
1	VALVE, WATER LUBE SOLENOID	016140	1	
2	SCREW, 4MM X 12 CROSS SLOT ROUND HEAD	F05004-74	2	
3	WASHER, 4MM SPLIT LOCK	F05011-57	2	
4	FITTING, 1/4" MALE NPT 3/8" HOSE BARB	P04682	1	
5	FITTING, 1/4" MALE NPT 3/8" HOSE BARB ELBOW	P04730	1	

4.3 Board Return Assembly

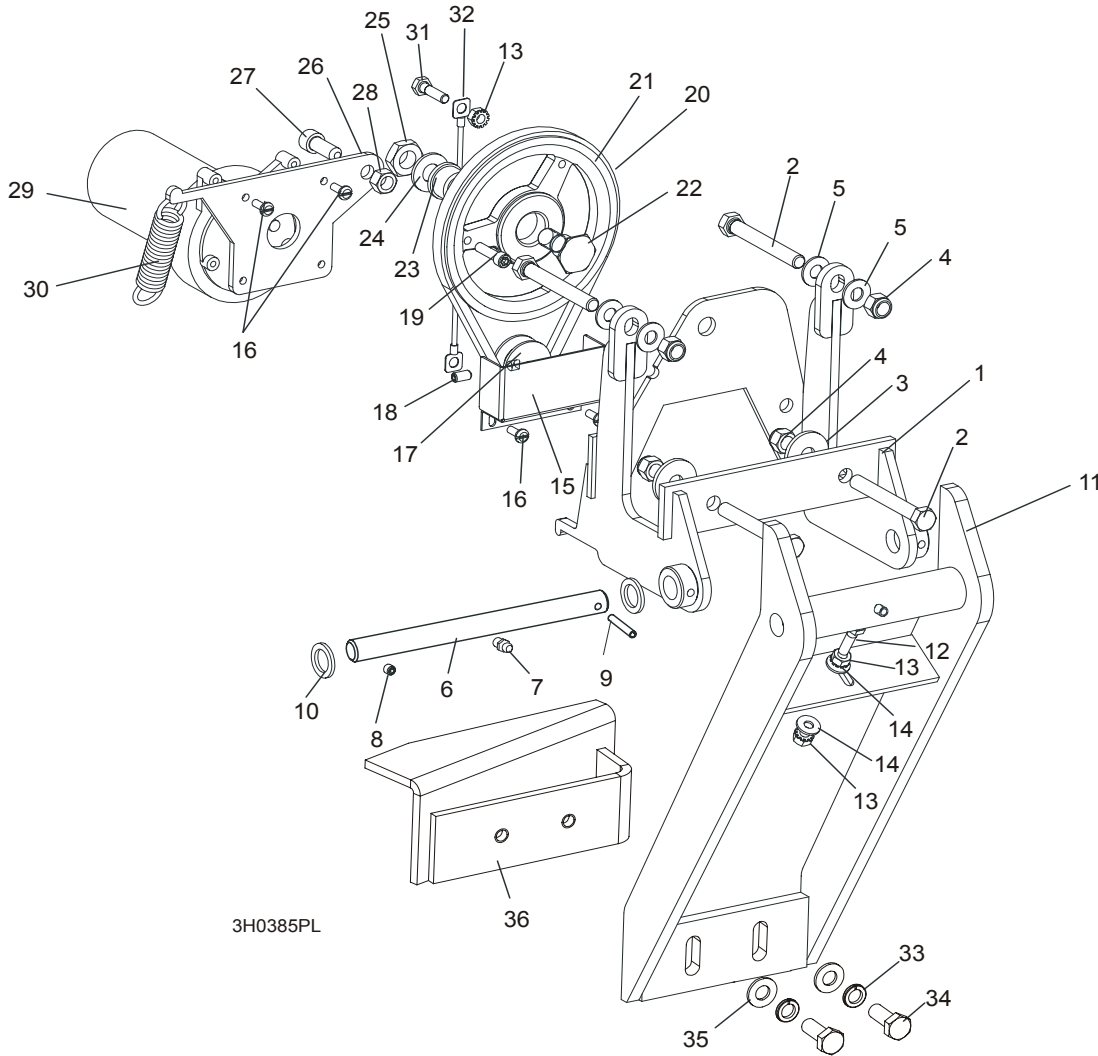

REF	DESCRIPTION (◆ Indicates Parts Available In Assemblies Only)	PART #	QTY.
	RETURN ASSEMBLY, BOARD	087839-1	1
1	Mount Weldment, Board Return	087788-1	1
2	Bolt, 3/8-16 x 3" Full Thread Hex Head	F05007-1	4
3	Washer, 1/8" x 1 1/4"	015336	2
4	Nut, 3/8-16 Hex Nylon Lock	F05010-10	4
5	Washer, 10.5 Flat	F81055-1	4
6	Pin Kit, Board Return Replacement Pivot	087837	1
7	Fitting, M6 Grease	086280	1
8	Screw, M6 X 8 Black Oxide Socket Head Set Cup Point	F81013-1	1
9	Pin, 5 X 30 Roll	F81044-21	1
10	Washer, 5/8" x 15/16" x .094 Nylon	F05011-19	2
11	Arm Weldment, Board Return	087838-1	1
12	Screw, 1/4-20 x 3/4" Full Thread Hex Head Cap	F05005-101	1
13	Nut, 1/4-20 Self Locking	F05010-9	3

4

Saw Head*Board Return Assembly*

14	Washer, 7.4 Flat	F81056-11	2	
15	Guard, Board Return Belt	015007	1	
16	Screw, 10-32 x 1/2" Hex Head Machine	F05004-55	4	
17	Sheave, 1.42 x .32	015074	1	
18	Screw, 1/4-20 Socket Head Set Cup Point Nylon	F05005-55	1	
19	Screw, 1/4-20 x 1" Socket Head Cap	F05005-89	1	
20	Belt, 3L190	015477	1	
21	Sheave, OK50 x 1/2" Modified	015224	1	
22	Bolt, Idler Pulley Pivot	015221	1	
23	Bushing, 5/8" x 7/8" x 1/2" Bronze	P05135	1	
24	Washer, 13 Flat	F81056-1	1	
25	Nut, 1/2-20 Jam Nylon Lock	F05010-79	1	
26	Plate, Motor Pivot	087871	1	
27	Screw, M10 x 25-8.8 Black Oxide Socket Head Cap	F81003-32	1	
28	Nut, 3/8-16 Self Locking	F05010-25	1	
29	Motor, 53:1 ASA Gear	P09698-1	1	
30	Spring, 3/4" x 2 7/8" x 12 Gauge	015479	1	
31	Bolt, 1/4-20 x 1" Hex Head Grade 5	F05005-101	1	
32	Cable, Board Return	016090	1	
33	Washer, 10.2 Split	F81055-2	2	
34	Bolt, 3/8-16 x 3/4" Hex Head	F81003-1	2	
35	Washer, 10.5 Flat	F81055-1	2	
36	Angle, Board Return	087835-1	1	

4.4 Water Lube Assembly

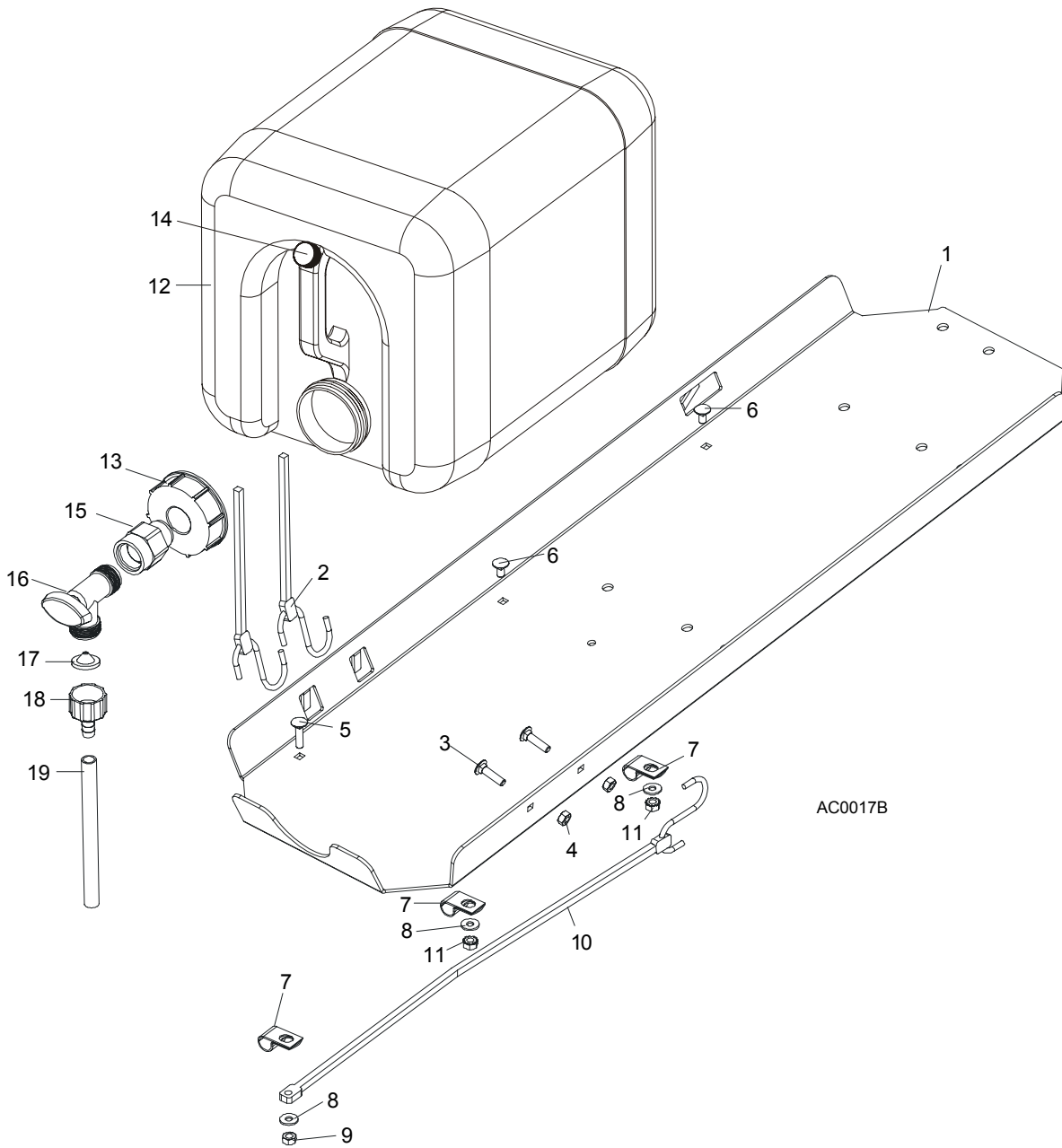

REF	DESCRIPTION (◆ Indicates Parts Available In Assemblies Only)	PART #	QTY.	
1	TRAY, ELECTRIC BOX/WATER BOTTLE	086528-1	1	◆
2	STRAP, 20" RUBBER	P11668	2	
3	BOLT, 1/4-20 X 1" CARRIAGE HEAD	F05005-34	4	
4	NUT, 1/4-20 HEX LOCK	F05010-21	4	
5	BOLT, 1/4-20 X 1" CARRIAGE HEAD	F05005-34	1	
6	BOLT, 1/4-20 X 1/2" CARRIAGE HEAD	F05005-33	2	
7	CLAMP, 1/2" EMT HOSE	P07584	3	
8	WASHER, 7.4 FLAT	F81056-11	3	
9	NUT, 1/4-20 HEX LOCK	F05010-21	1	

4

Saw Head*Water Lube Assembly*

10	STRAP, 15" RUBBER	P07461	1	
11	NUT, 1/4-20 SELF-LOCKING	F05010-9	2	
	BOTTLE, 5-GALLON WATER COMPLETE	014637-1	1	
12	BOTTLE, 5-GALLON WATER	101295	1	
13	CAP, 5-GALLON WATER BOTTLE	036745	1	
14	CAP, VENT VALVE	061742	1	
15	FITTING, 3/4FPT X 3/4MPT	014636	1	
16	FITTING, WATER LUBE SHUTOFF VALVE	014100	1	
17	FILTER, WATER LUBE	016086 ¹	1	
18	FITTING, 5/8" NPT TO 3/8" HOSE BARB	014113	1	
19	TUBING, WATER LUBE 3/8" I.D.	R01885	2,1 m	

¹ Filter recommended for Super models to prevent debris from entering water lube solenoid valve.

4.5 LT40AC Saw Head Decals

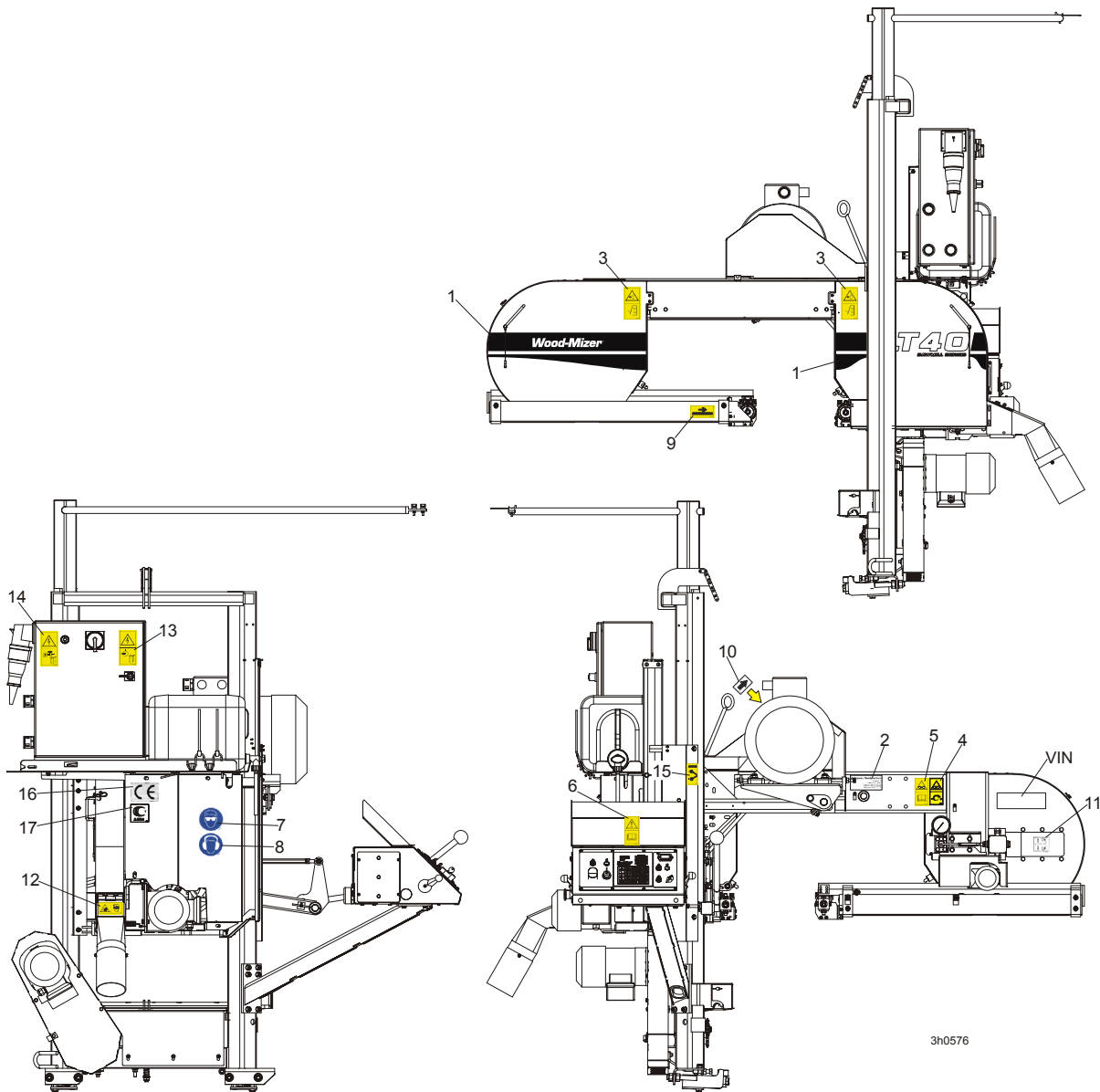

3h0576

REF	DESCRIPTION (◆ Indicates Parts Available In Assemblies Only)	PART #	QTY.
1	DECAL, LT40 SERIES SAWMILL	092763	1
	PICTOGRAPHIC DECAL KIT, LT40AC	099516	1
2	DECAL, EUROPEAN HEADQUARTERS ADDRESS	015841	1
3	DECAL, SAWMILL COVERS CAUTION	099220	2
4	DECAL, BLADE TENSION (PICTOGRAM)	099219	1
5	DECAL, BLADE TENSION - INSTRUCTIONS (PICTOGRAM)	099223	1
6	DECAL, READ OPERATOR'S MANUAL (PICTOGRAM)	096317	1
7	DECAL, EYE PROTECTION WARNING (PICTOGRAM)	S12004G	1
8	DECAL, EAR PROTECTION WARNING (PICTOGRAM)	S12005G	1
9	DECAL, BLADE MOVEMENT DIRECTION (PICTOGRAM)	096321	1
10	DECAL, MOTOR ROTATION DIRECTION	S20097	1
11	DECAL, BLADE ALIGNMENT	P11789	1

4**Saw Head***LT40AC Saw Head Decals*

12	DECAL, SAWDUST CHUTE WARNING (PICTOGRAM)	099222	1	
13	DECAL, HIGH VOLTAGE INSIDE THE ELECTRIC BOX (PICTOGRAM)	096316	1	
14	DECAL, REMOVE THE PLUG BEFORE OPENING THE BOX (PICTOGRAM)	096319	1	
15	DECAL, BLADE DRIVE WARNING (PICTOGRAM)	096315	1	
16	DECAL, CE CERTIFIED SAWMILL (SMALL)	P85070	1	
17	DECAL, RUSSIAN SAFETY CERTIFICATION	099401	1	

4.6 Blade Housing Covers

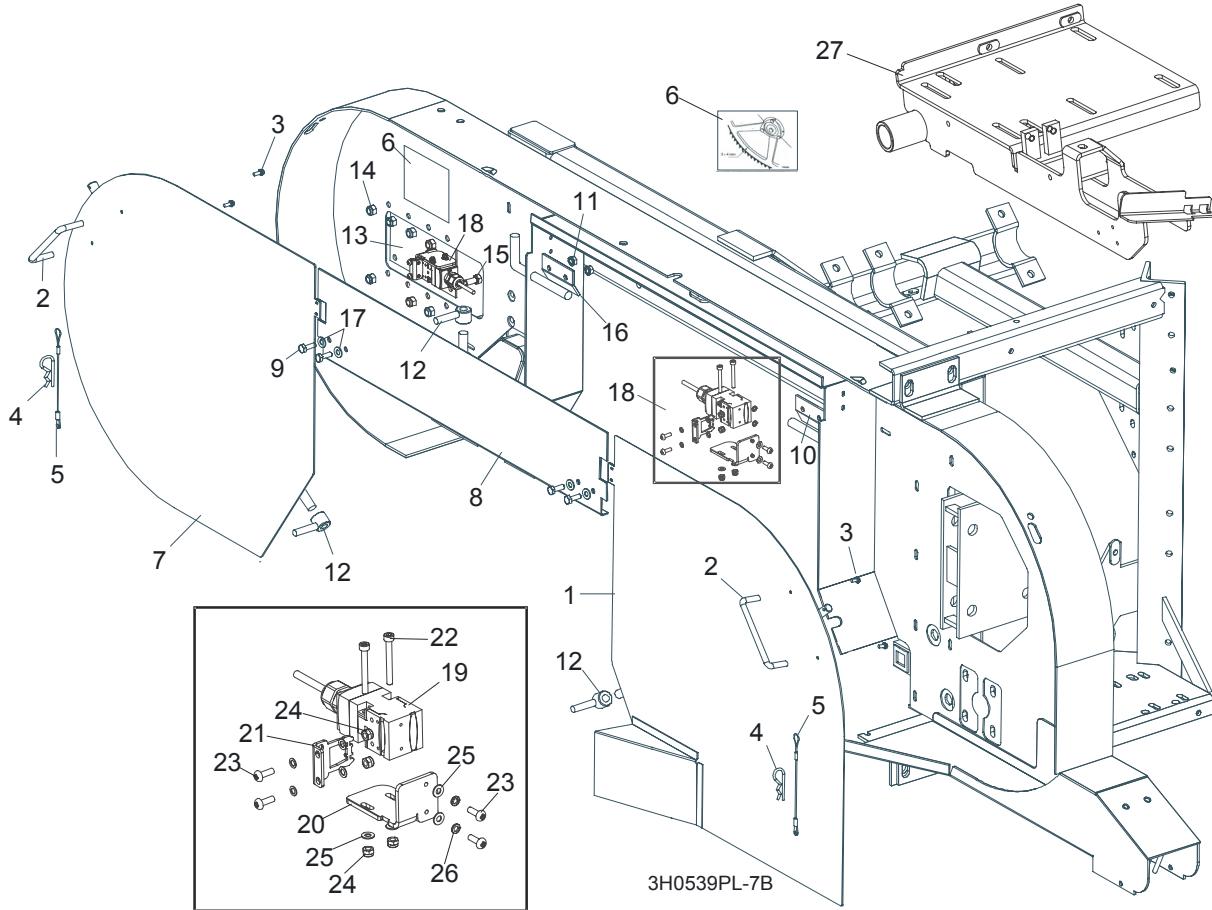

REF	DESCRIPTION (◆ Indicates Parts Available In Assemblies Only)	PART #	QTY.
	COVER ASSEMBLY, DRIVE SIDE BLADE HOUSING WITH HANDLE	086195	1
1	Cover Weldment, Drive Side Blade Housing	087159-1	1 ◆
2	Handle, Blade Housing Cover	P08065	1
3	Screw, #8-32 x 3/8"	F05015-8	2
	Pin Assembly, Cover Retainer	A11881	1
4	Pin, Safety Retainer	N/A	1
5	Cable, 3/64" x 6" Lanyard	N/A	1
6	DECAL, BLADE SETTING	P85066	1
	COVER, IDLE SIDE BLADE HOUSING WITH HANDLE	086431	1
7	Cover, Idle Side Blade Housing	086430-1	1 ◆
2	Handle, Blade Housing Cover	P08065	1
3	Screw, #8-32 X 3/8" Self-Tap	F05015-8	2
	Pin Assembly, Cover Retainer	A11881	1
4	Pin, Safety Retainer	N/A	1
5	Cable, 3/64" x 6" Lanyard	N/A	1
8	COVER, MIDDLE BLADE HOUSING	087326-1	1
9	BOLT, 1/4-20 X 3/4" HEX HEAD	F05005-1	4

4

Saw Head*Blade Housing Covers*

10	HINGE, MIDDLE BLADE HOUSING COVER	S07522	1	
11	NUT, 1/4-20 SELF-LOCKING HEX	F05010-9	4	
12	NUT, COVER TURN	086365-1	2	
13	PLATE, IDLE BLADE WHEEL GUARD	086230	1	
14	NUT, 5/16-18 HEX NYLON LOCK	F05010-58	6	
15	BOLT, 5/16-18 X 3/4" HEX HEAD GRADE 2	F05006-5	6	
16	HINGE, MIDDLE BLADE HOUSING COVER	085336-1	1	
17	WASHER 6.4 ZINC	F81053-1	4	
18	SWITCH ASSEMBLY, SAFETY SHUT-OFF	094301	2	
19	Safety Switch, AZ17-11ZRK	094232	2	
20	Bracket, Safety Switch Mount Painted	094300-1	2	
21	Key, AZ17/170-B5 Safety Switch	094422	2	
22	Bolt, M4 x 35-8.8 Socket Head	F81011-34	4	
23	Screw, M4 x 12-5.8	F81011-43	8	
24	Nut, M4 Hex	F81029-1	8	
25	Washer, M4 Split Lock Zinc	F81051-1	4	
26	Washer, 4.3	F81051-2	8	
27	MOUNT WELDMENT E15,E20,E25	087736-1	1	

4.7 Drive Belt Covers

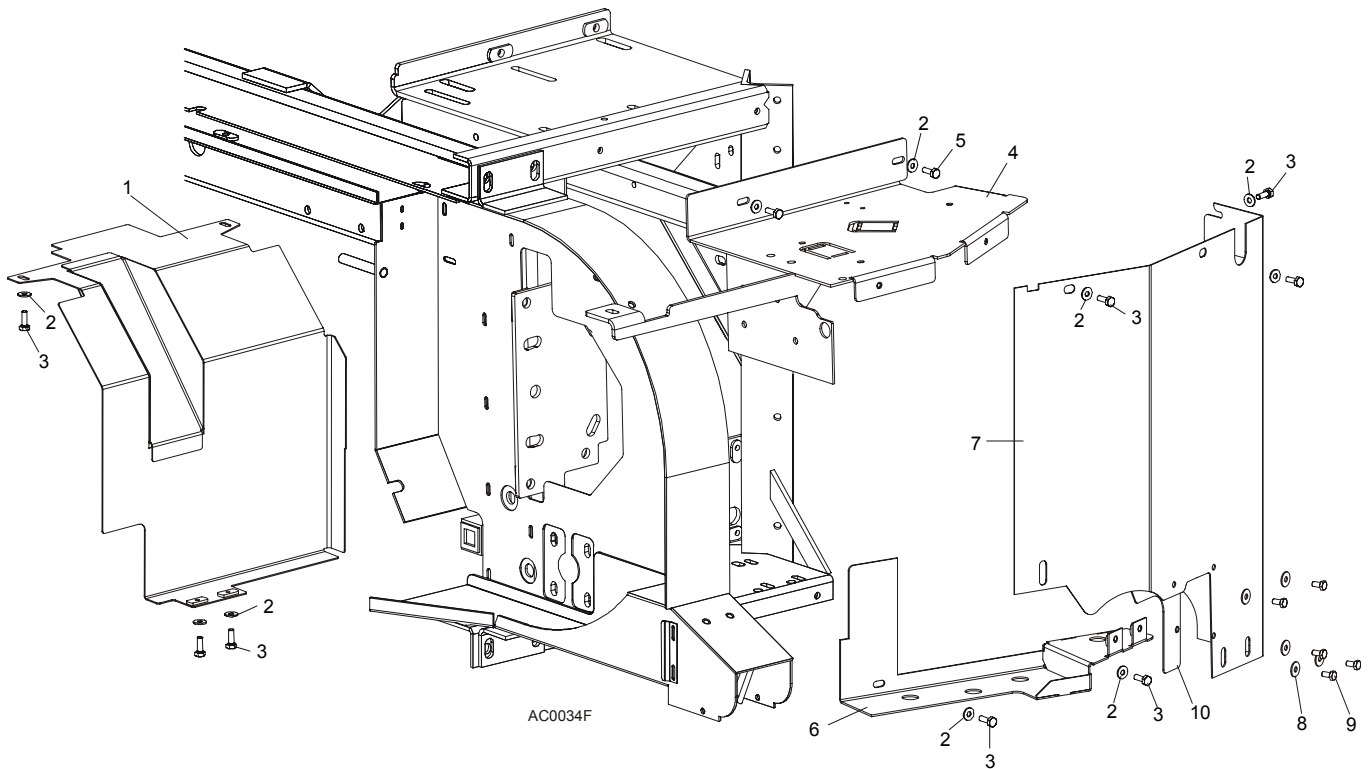

REF	DESCRIPTION (◆ Indicates Parts Available In Assemblies Only)	PART #	QTY.
1	GUARD, E15/E20/E25 BELT LOWER PAINTED	087660-1	1
2	WASHER, 6.5 SPECIAL FLAT ZINC	F81053-11	11
3	BOLT, M6 X 20-8.8 HEX HEAD FULL THREAD ZINC	F81001-2	9
4	GUARD WELDMENT, AC SAW HEAD UPPER PAINTED	086621-1	1
5	BOLT, M6 X 12-8.8 HEX HEAD FULL THREAD ZINC	F81001-7	2
	GUARD, AC SIDE PAINTED COMPLETE (WITHOUT BRAKE)	100621	1
	GUARD, AC SIDE PAINTED COMPLETE (WITH BRAKE)	100622	1
6	GUARD, AC LOWER	087525-1	1
7	GUARD, AC SIDE PAINTED (WITHOUT BRAKE)	086420-1	1
	GUARD, AC SIDE PAINTED (WITH BRAKE)	087333-1	1
8	WASHER, 6.5 SPECIAL FLAT ZINC	F81053-11	5
9	BOLT, M6 X 12-8.8 HEX HEAD FULL THREAD ZINC	F81001-7	5
10	PLATE, CAP COMPLETE	501393-1	1

4.8 Sawdust Chute

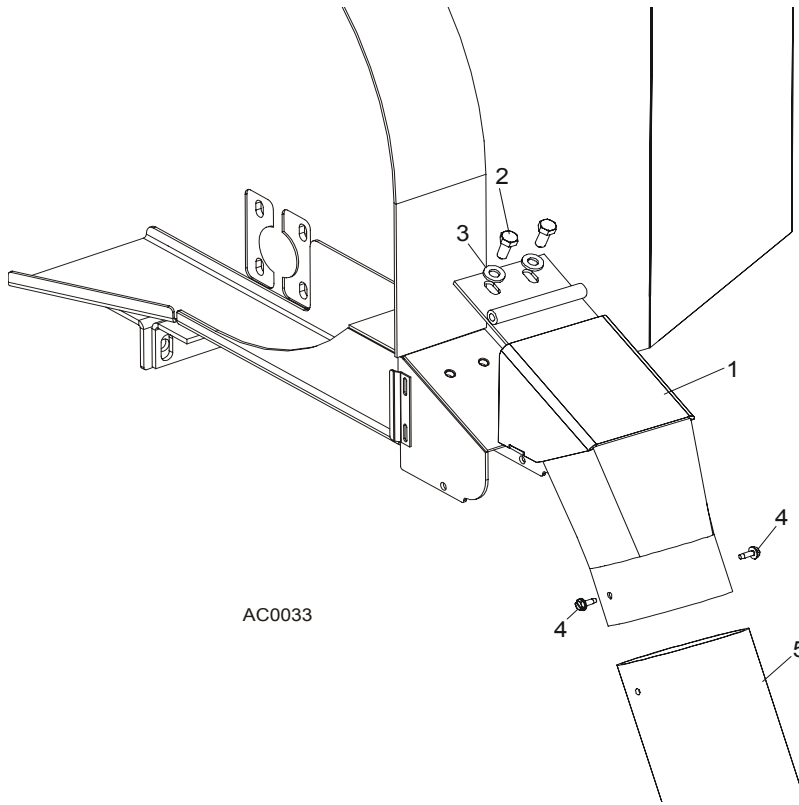

REF	DESCRIPTION (◆ Indicates Parts Available In Assemblies Only)	PART #	QTY.	
1	CHUTE WELDMENT, SAWDUST	100903-1	1	
2	BOLT, M8x16	F81002-20	2	
3	WASHER, 8.4 FLAT	F81054-1	2	
4	BOLT, #10-24 X 1/2" SELF-TAPPING	F05015-7	2	
5	TUBING, 4" I.D. RUBBER	086364	0.6 m	
	STRAP, 20" RUBBER W/HOOK	P11668	1	
	BOLT, 1/4-20 X 1 1/4" HEX HEAD FULL THREAD	F05005-3	1	
	WASHER, 7.4 FLAT	F81056-11	1	
	NUT, 1/4-20 LOCK	F05010-21	1	

SECTION 5 CONTROL & BATTERY BOXES

5.1 Control Assembly, LT40 Series AH

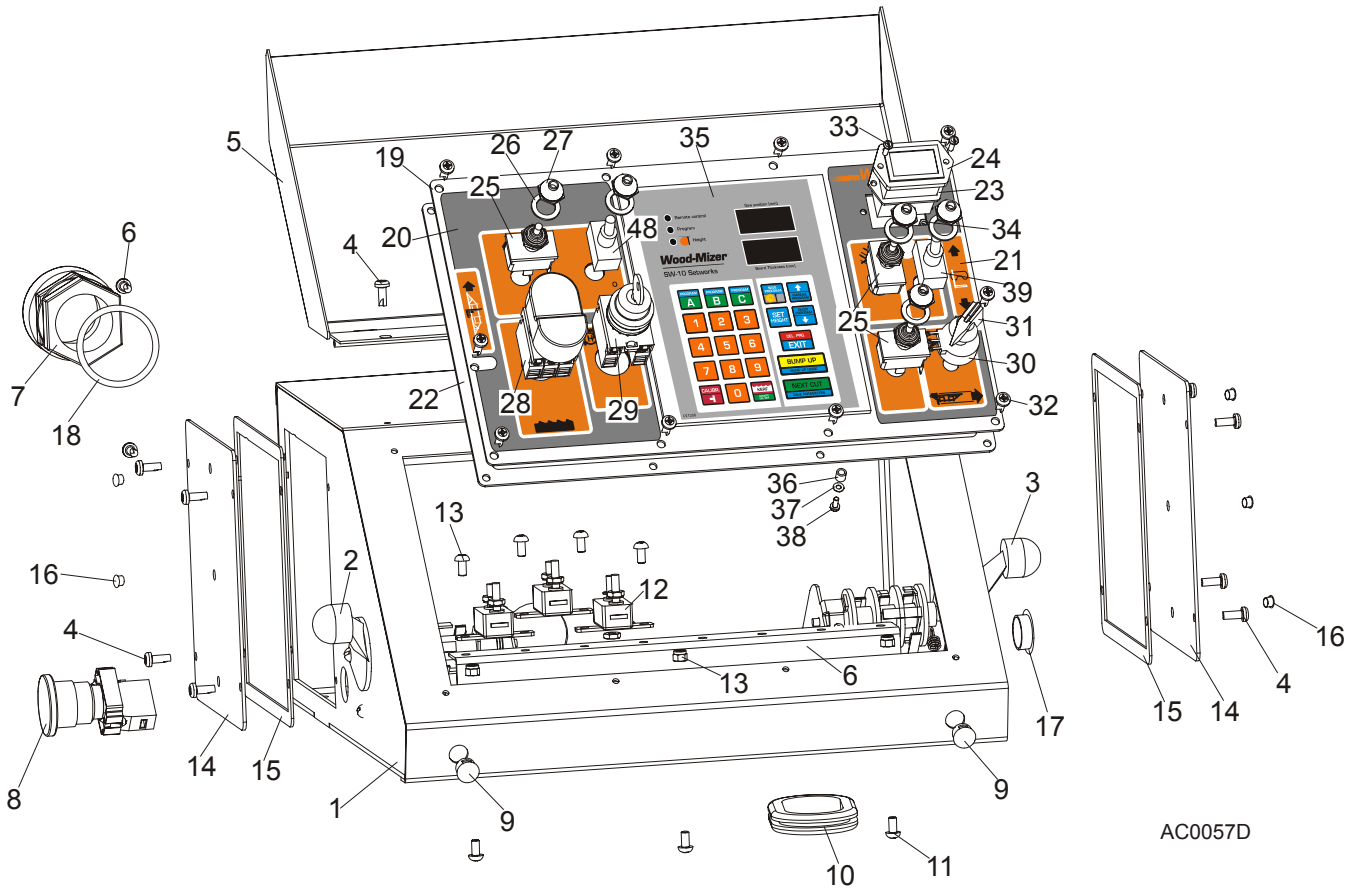

REF	DESCRIPTION (◆ Indicates Parts Available In Assemblies Only)	PART #	QTY.
	CONTROL BOX ASSEMBLY, LT40 AC	098690	1
1	Control Box, LT40AC	099622-1	1
2	Switch, 1992GS Pwr/Feed (Service Package)	E20438	1
3	Switch, 1992 Up/Down (Service Package)	E20440	1
4	Bolt, #10-24x1/2 Ph Pan Hd, Type 23	F05015-17	12
5	Cover Weldment, LT20/40 Complete	097135-1	1
6	Rail, Circuit Breaker	015310	1
7	Connector, 1 1/4 Straight Metal Conduit	024402	1
8	Switch, XB2 BS542 Emergency	086556	1
9	Switch, Speed Control	086773	2
10	Grommet, Rubber	087065	1
11	Screw, H M5x10 8.8 Zinc	F81000-13	7
12	Breaker, 15A Manual Reset	E20430	3
13	Nut, M5-8 Zinc	F81030-2	3
	Cover, Control Box Side Complete	086700	2
14	Cover, Control Box Side	086699-1	1
15	Gasket, Control Box Side	015274	1

16	Cap, SR1086 6.4 Dia. Hole	099700	6	
17	Cap, SR1086 22.2 Dia. Hole	093544	1	
18	Seal, 1 1/4 Ring LQTI w/Retainer	015430	1	
	Panel, LT40 AC Front Control Complete	098689	1	
19	Panel, LT20/40 AC Front Control	100572-1	1	
	Panel, LT40 AC Front Control	098586-1 ¹	1	
20	Decal, LT20/40 AC Control Box Left	099594	1	
21	Decal, LT40 DC Control Box Right	099596	1	
22	Gasket, LT20/40 Control Box	097132	1	
23	Gasket, Hour Meter	093346	1	
24	Meter, Hour	093166	1	
25	Switch, Toggle	024000	3	
26	Washer, 1/2x3/4x1/16 Nylon	P05251-1	5	
27	Boot, Toggle Switch	P02575	5	
28	Button, 24V Start/Stop	090452	1	
	Membrane M22-T-DD	090462	1	
29	Switch, M22 3-position Key	091361	1	
30	Potentiometer, 1k Feed Rate	E20519	1	
31	Knob, Speed Control	P06257	1	
32	Bolt, #10-24x1/2 Ph Pan Hd, Type 23	F05015-17	10	
33	Bolt, M3x12-8.8 Zinc	F81000-12	2	
34	Nut, M3-6 Nylon Zinc Lock	F81028-2	2	
35	Controller, SW-10 Setworks	500628	1	
36	Spacer, 4.2x6mm Idler	R80671-4	6	
37	Washer, 3.2 Flat Zinc	F81050-2	6	
38	Screw, M3x8-4.8 Zinc	F81000-83	6	
39	Switch, SPST On/Off 15A .25 TABS Toggle	P03027	2	

¹ Use in African version only.

5.2 Drum Switches

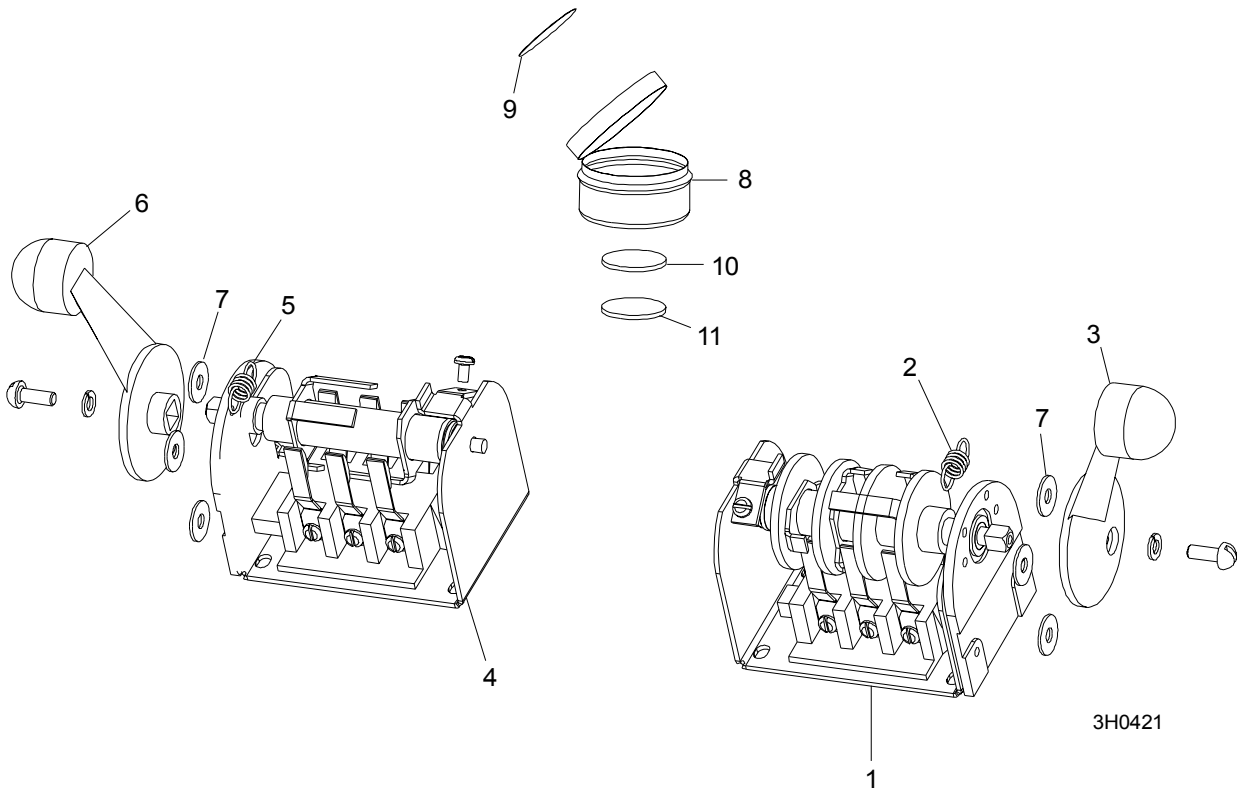

REF	DESCRIPTION (◆ Indicates Parts Available In Assemblies Only)	PART #	QTY.	
	SWITCH ASSEMBLY, UP/DOWN DRUM	E20440	1	
1	Switch, S12 Bulk Drum	E20440-B	1	◆
2	Spring, Drum Switch	P12570	1	
3	Handle, Drum Switch Replacement	P12500	1	
	SWITCH ASSEMBLY, POWER FEED DRUM	E20438	1	
4	Switch, S10 Bulk Drum	E20438-B	1	◆
5	Spring, Drum Switch	P12570	1	
6	Handle, Drum Switch Replacement	P12500	1	
7	WASHER, #8 SAE FLAT	F05011-41	6	
	CUP ASSEMBLY, DRUM SWITCH GREASE	A20463	1	
8	Cup, Plastic Container	P20464	1	◆
9	Decal, Grease Cup Label	P20467	1	
10	Pad, Velcro Loop	P20466	1	◆
11	Pad, Velcro Hook	P20465	1	◆
	Grease, High Temp Drum Switch	P20468	.011ml	◆

5.3 Circuit Breakers

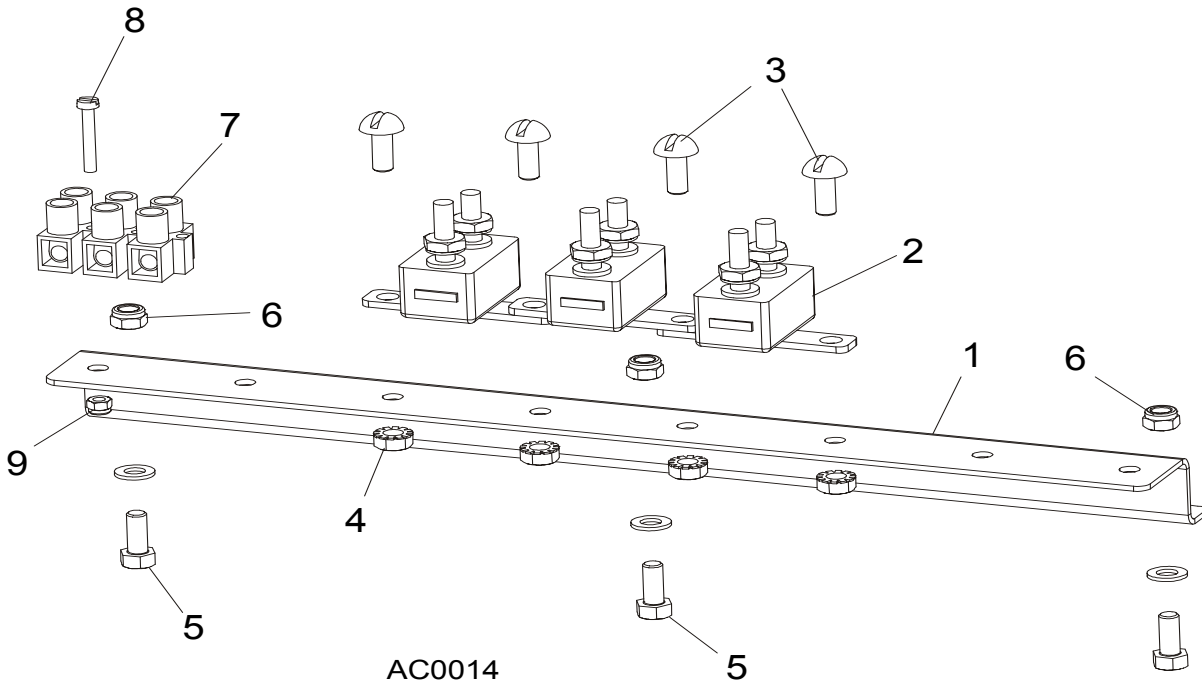

REF	DESCRIPTION (◆ Indicates Parts Available In Assemblies Only)	PART #	QTY.
1	RAIL, CIRCUIT BREAKER	015310	1
2	BREAKER, 15 AMP MANUAL RESET	E20430	5
3	SCREW, H M5X10 8.8 ZINC	F81000-13	4
4	NUT, M5-8 ZINC HEX SELF-LOCKING	F81030-2	4
5	SCREW, M5X12-5.8 ZINC	F81000-5	3
6	NUT, M5-8 ZINC HEX SELF-LOCKING	F81030-2	3
7	STRIP, ELECTRIC WIRE	F81086-1	1
8	SCREW, M3 X 20-5.8	F81000-8	1
9	NUT, M3	F81028-2	1

SECTION 6 UP/DOWN SYSTEM

6.1 Saw Head V-Brace Mount

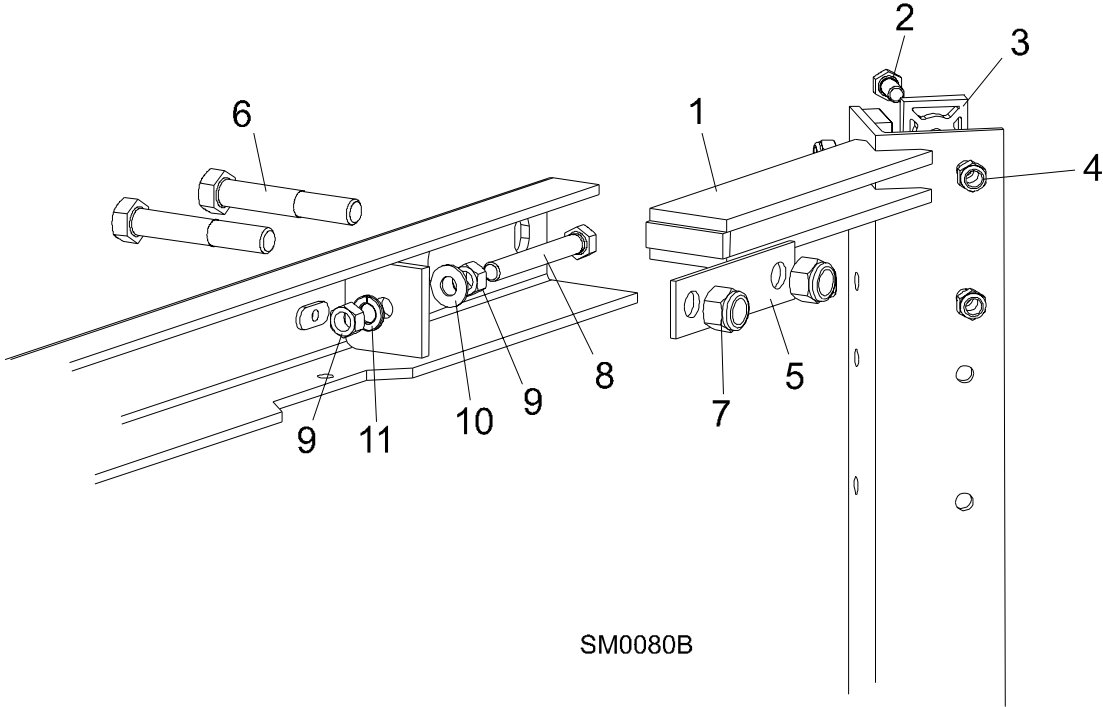

REF	DESCRIPTION (◆ Indicates Parts Available In Assemblies Only)	PART #	QTY.
1	V-BRACE, SAW HEAD MOUNT	086308	1
2	BOLT, 5/16-18 X 3/4" HEX HEAD GRADE 5	F05006-5	19
	BOLT, 5/16-18 X 1 1/4" HEX HEAD FULL THREAD	F05006-18	5
3	PAD, PLASTIC SLIDE	M04096	12
4	NUT, 5/16-18 NYLON LOCK	F05010-58	19
	NUT, 5/16-18 HEX	F05010-17	5
5	PLATE, V-BRACE WASHER	091247	4
6	BOLT, M12 X 40 - 8.8 HEX HEAD	F81004-1	4
7	NUT, M12 - 8 NYLON LOCK	F81034-2	4
8	BOLT, 3/8-16 X 3" FULL THREAD	F05007-1	2
9	NUT, 3/8-16 HEX	F05010-1	4
10	WASHER, 10.5 FLAT	F81055-1	2
11	WASHER, 10.2 SPLIT LOCK	F81055-2	2

6.2 Blade Height Scale

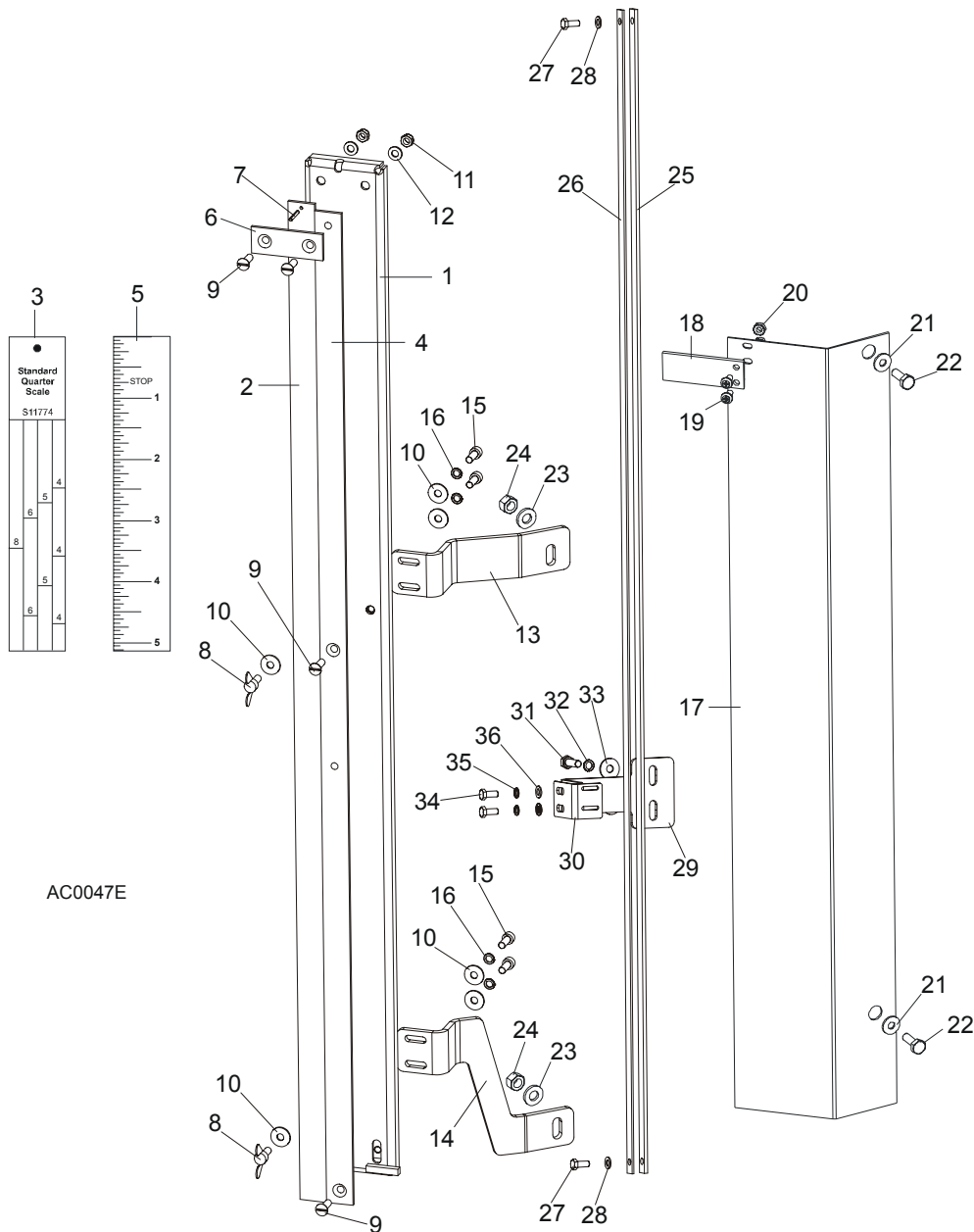

AC0047E

REF	DESCRIPTION (◆ Indicates Parts Available In Assemblies Only)	PART #	QTY.
	SCALE, BLADE HEIGHT W/SCANNER	098882	1
1	Bracket, Scale Mounting	098890-1	1
2	Scale, 35" Quarter	093342	1
3	Decal, 35" Standard Quarter Scale	090716	1
	Decal, 35" Grade Hardwood Quarter Scale	090717	1
4	Scale, 35" Inch	093341	1
5	Decal, 35" Inch	090709	1
6	Strap, Scale Hold-Down	093134	1
7	Pin, 3x20 Roll	F81044-5	1
8	Screw, M6x16 Wing	F81001-16	2
9	Screw, M6x20- 4.8-B	F81001-31	4

10	Washer, 6.5 Flat	F81053-11	7	
11	Nut, M6, Hex, Nylon Lock Zinc	F81031-2	2	
12	Washer, M6, Flat, Zinc	F81053-1	2	
13	Bracket, Scale Upper	098880-1	1	
14	Bracket, Scale Lower	098881-1	1	
15	Bolt, M6x16-8.8 Socket Head	F81001-21	4	
16	Washer, M6 Split Lock Zinc	F81053-3	4	
	Pointer Assembly, Fixed Scale	A12023	1	
17	Bracket, Fixed Scale Pointer Mount	087044-1	1	◆
18	Indicator, Blade Height Scale	094821	1	
19	Screw, M4x12 -5,8-B- Fe/Zn5	F81011-43	2	
20	Nut, M4-B Fe/Zn5	F81029-1	2	
21	Washer, 6.5 Flat	F81053-11	2	
22	Bolt, M6x12-8.8-Zinc	F81001-7	2	
23	Washer, 8.4 Flat	F81054-1	2	
24	Nut, M8-8-B Hex Lock	F81032-2	2	
	MAGNETIC STRIP ASSY	097774	1	
	Bar with Magnetic Strip	098173-1	1	
25	Magnetic Strip MB320 (1m)	096014-1	1	
26	Bar, Magnetic Strip	098173	1	
27	Bolt, M5 X 12-5.8-Fe/Zn5	F81000-5	2	
28	Washer, M5, Flat zinc	F81052-1	2	
	BRACKET, SENSOR COMPLETE	100620	1	
29	Bracket, Sensor	100599-1	1	
30	Bracket, Sensor	100619-1	1	
31	Bolt, M6x20-8.8 Hex Head Full Thread Zinc	F81001-2	2	
32	Washer, Z6.1 Split Lock Zinc	F81053-3	2	
33	Washer, 6.5 Flat Zinc	F81053-11	2	
34	Bolt, M5 X 12-5.8-Fe/Zn5, PN-M/82105	F81000-5	2	
35	Washer, 5.1 Split Lock Zinc	F81052-2	2	
36	Washer, 5.3 Flat Zinc	F81052-1	2	
	DECAL KIT, METRIC SCALE	K12064	1	
	Decal, Metric	S11711	1	
	Decal, Metric 16-40mm	P12040-1	1	
	Decal, Metric 45-63mm	P12040-2	1	

6.3 Up/Down Chain & Sprockets

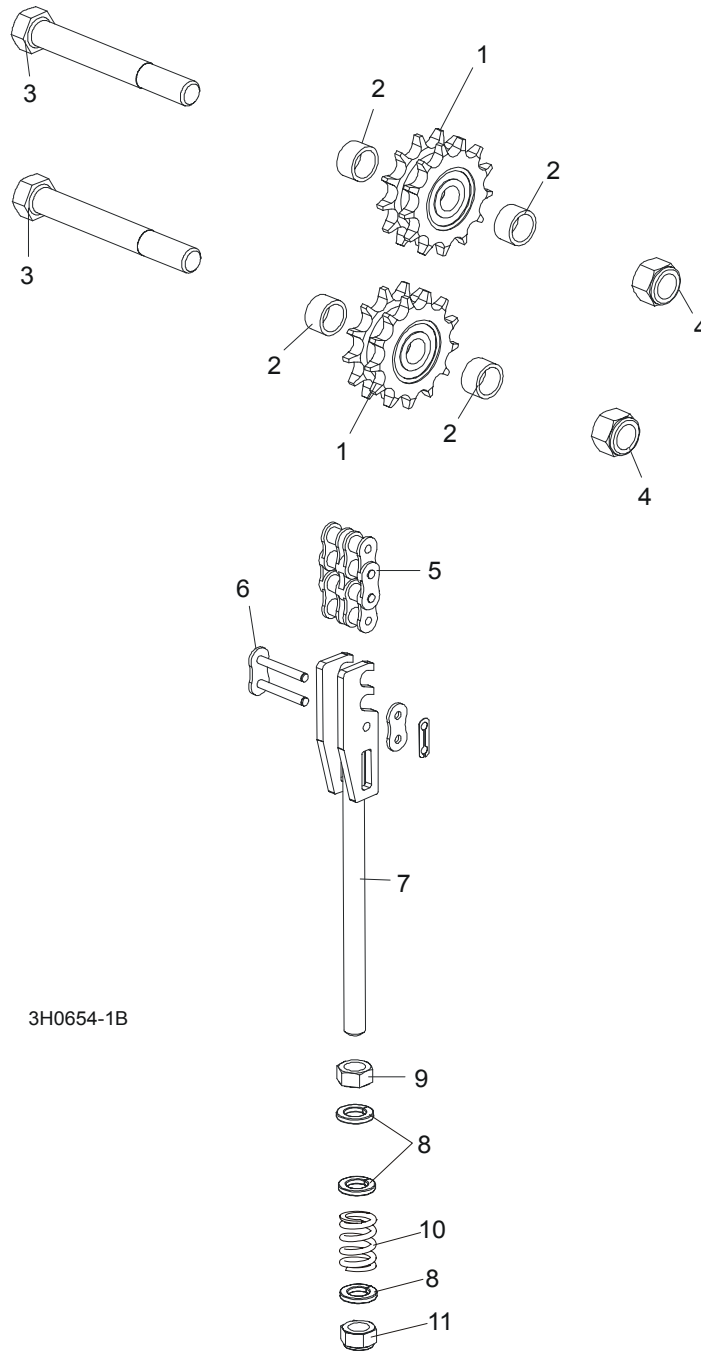

REF	DESCRIPTION (◆ Indicates Parts Available In Assemblies Only)	PART #	QTY.
	SPROCKET KIT, UP/DOWN IDLER #50-2	016020	1
1	Sprocket, Up/Down Idler '98	016019	2
2	Washer, Sprocket Spacer	095927-1	4
	Instruction Sheet, Up/Down Idler Retrofit	016020-541	1
3	BOLT, 5/8-11 X 5" HEX HEAD GRADE 2	F05009-6	2
4	NUT, 5/8-11 HEX NYLON LOCK	F05010-34	2
5	CHAIN, #50-2 X 75.625" UP/DOWN	015259	1
6	LINK, #50-2 MASTER	015258	2
	TENSIONER ASSEMBLY, UP/DOWN CHAIN	094283	1

7	Bracket, Up/Down Chain Tensioner	094281-1	1	◆
8	Washer, M12, Flat, Zinc	F81056-1	3	
9	Nut, M12-8-B Hex	F81034-1	1	
10	Spring, 14x30x3.2	090797	1	
11	Nut, M12, Hexagon, Nylon, Zinc, Lock	F81034-2	1	

6.4 Up/Down Motor Assembly, LT40 Series AH

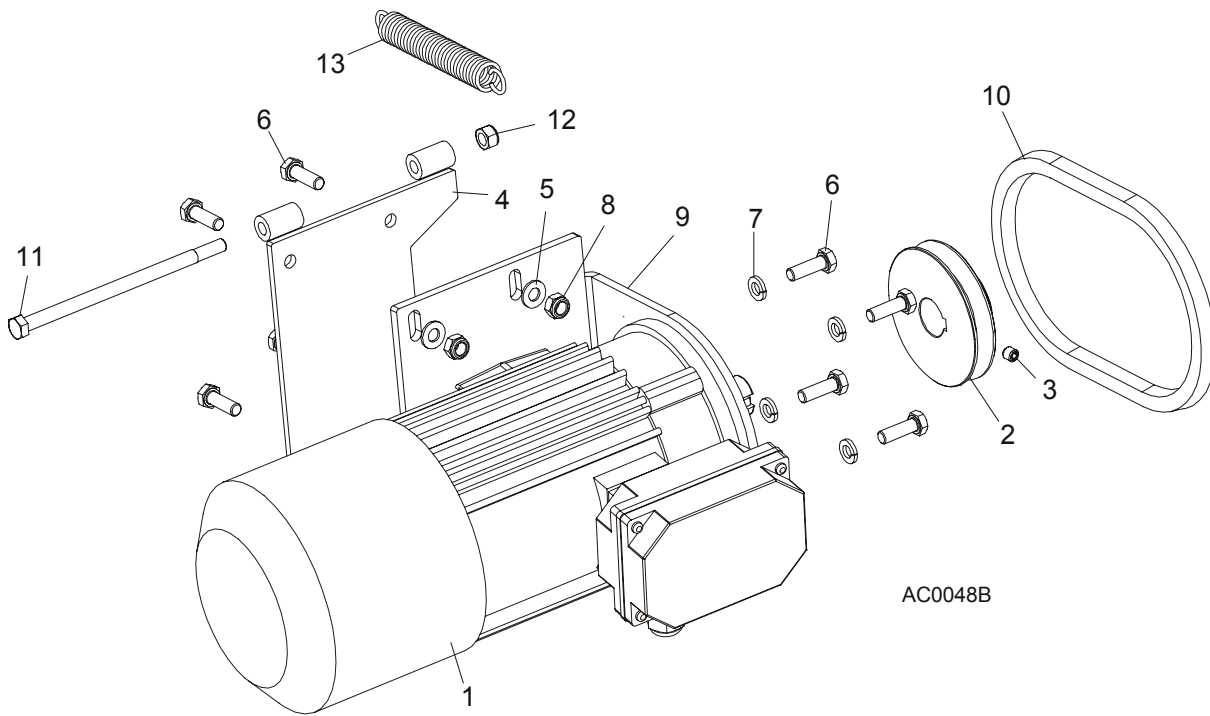

REF	DESCRIPTION (◆ Indicates Parts Available In Assemblies Only)	PART #	QTY.
	UP/DOWN MOTOR ASSEMBLY, LT40AC	093023	1
1	Motor, SKh90-4S2 HPS 1,1kW, 1380obr./min 400V (w/brake)	098901	1
2	Pulley, AC Up/Down Motor Painted	086378-1	1
3	Screw, M8 x 8-33H Hex Socket Set Flat Point Zinc	F81014-1	1
4	Bracket Wdmt, Up/Down Motor	095738-1	1
5	Washer, 8.4 Split Lock	F81054-1	4
6	Bolt, M8 x 25 8.8 B Hex Head	F81002-4	8
7	Washer, 8.2 Split Lock	F81054-4	4
8	Nut, M8 8 B Hex	F81032-2	4
9	Bracket, AC Up/Down Motor Mount	086376-1	1
10	BELT, AX23	015257	1
11	BOLT, M8X160-8.8-B ZINC	F81002-22	1
12	NUT, M8-8-B NYLON LOCK HEX ZINC	F81032-2	1
13	SPRING, 3/4x 5x.095 EXTENSION	015569	1

6.5 Up/Down Drive Assembly

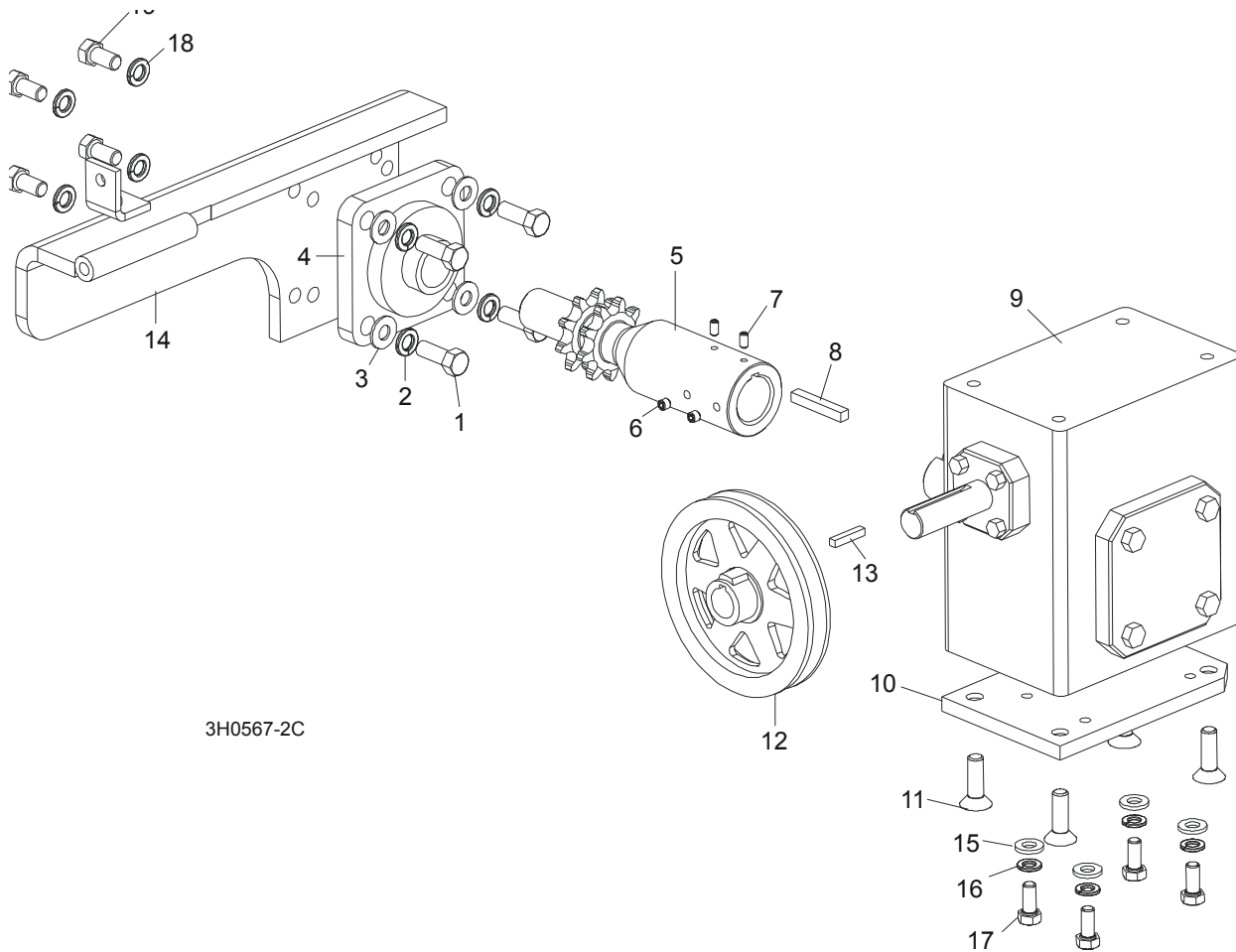

3H0567-2C

REF	DESCRIPTION (◆ Indicates Parts Available In Assemblies Only)	PART #	QTY.
	UP/DOWN DRIVE ASSEMBLY	092817	1
1	Bolt, 3/8-16 x 1" Hex Head	F05007-7	4
2	Washer, 10.2 Split Lock	F81055-2	4
3	Washer, 10.5 Flat	F81055-1	4
4	Bearing, Flanged Up/Down	014090	1
5	Shaft, Up/Down Sprocket	092816-1	1
6	Screw, M8 x 8-33H	F81014-1	2
7	Key, 1/4" Square x 1 11/16" Long	S04124	1
8	Spacer, Up/Down Shaft	016032	1
9	Reducer, Gear Box	014074	1
10	Plate, Gear Box Spacer	095894-1	1
11	Bolt, 3/8-16 x 1" Flat Socket Head	F05007-110	4
12	Pulley, Up/Down	015256	1
13	Key, 3/16" Square x 1" Long	S31027	1
14	Bracket Wdmt, Up/Down Bearing	095893-1	1
15	WASHER, 8.4 FLAT	F81054-1	4
16	WASHER, 8.2 SPLIT LOCK	F81054-4	4
17	BOLT, 5/16-18 X 1" HEX HEAD	F05006-5	4

6**Up/Down System***Up/Down Drive Assembly*

18	WASHER, 10.2 SPLIT LOCK	F81055-2	4	
19	BOLT, 3/8-16 X 3/4" HEX HEAD	F05007-27	4	
	OIL, 8 OZ. MOBIL SHC634 BOTTLED SYNTHETIC GEAR	L04869-4	1	

SECTION 7 POWER FEED & TRACK ROLLERS

7.1 Upper Track Rollers And Wipers

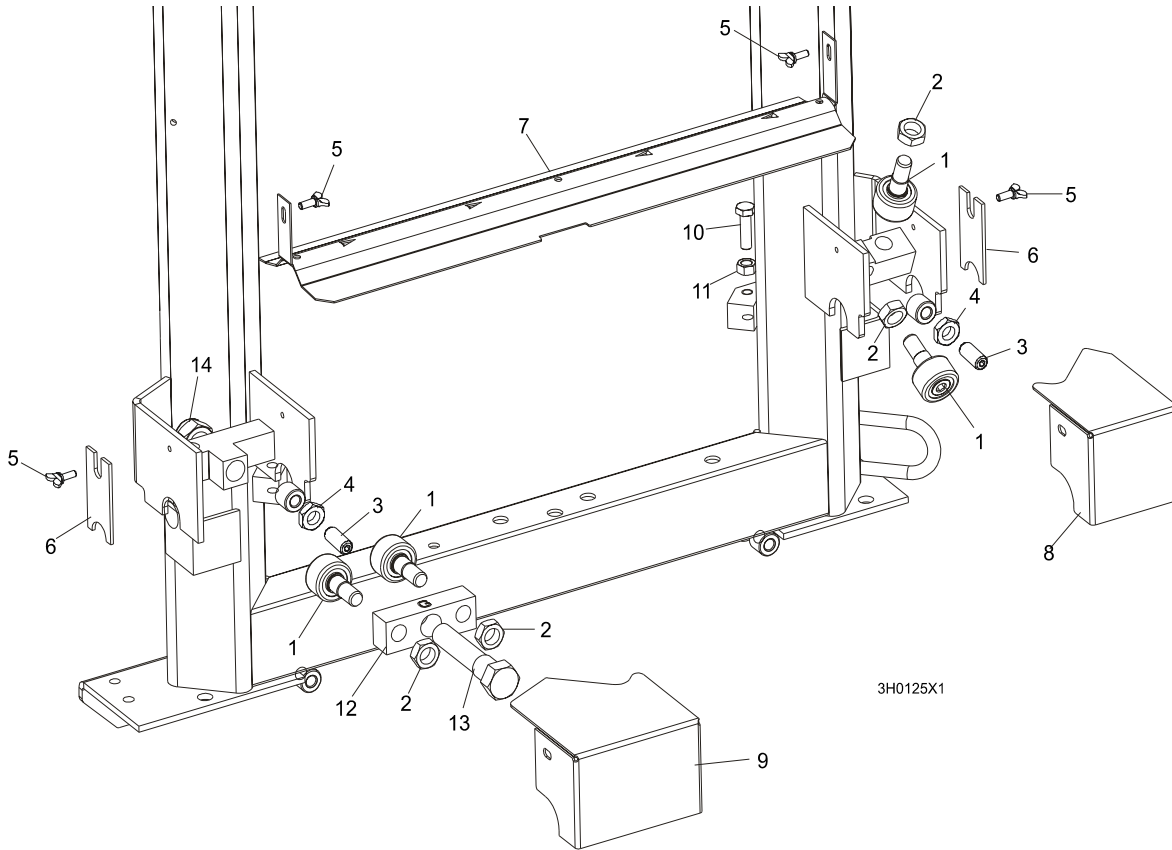

REF	DESCRIPTION (◆ Indicates Parts Available In Assemblies Only)	PART #	QTY.
1	ROLLER, TRACK CAM BEARING	P12843	4
2	NUT, 5/8-18 HEX JAM	F05010-11	4
3	SCREW, M12 X 30 OVAL POINT SET	F81004-14	2
4	NUT, M12-8-B HEX JAM	F81034-1	2
5	SCREW, M6 X 16 THUMB	F81001-16	4
6	WIPER, PLASTIC TRACK	M04113	2
7	COVER, LT40/70 MIDDLE TRACK - SERVICE	092868-S	1
	Cover, LT40/70 Middle Track Ptd	092868-1	1
	Strip, 3/16 X 2 X 23 Felt	S09915	1
8	HOUSING, UPPER TRACK ROLLER REAR	086913-1	1
9	HOUSING, UPPER TRACK ROLLER FRONT	086914-1	1
10	BOLT, M10 X 35-8.8 HEX HEAD	F81003-17	2
11	NUT, M10-8 HEX JAM	F81033-3	2
12	BRACKET, UPPER TRACK ROLLER	086859-1	1
13	BOLT, HEX HEAD	086911	1
14	NUT, M20-8 HEX	F81037-2	1

7.2 Power Feed Assembly, LT40 Series AH

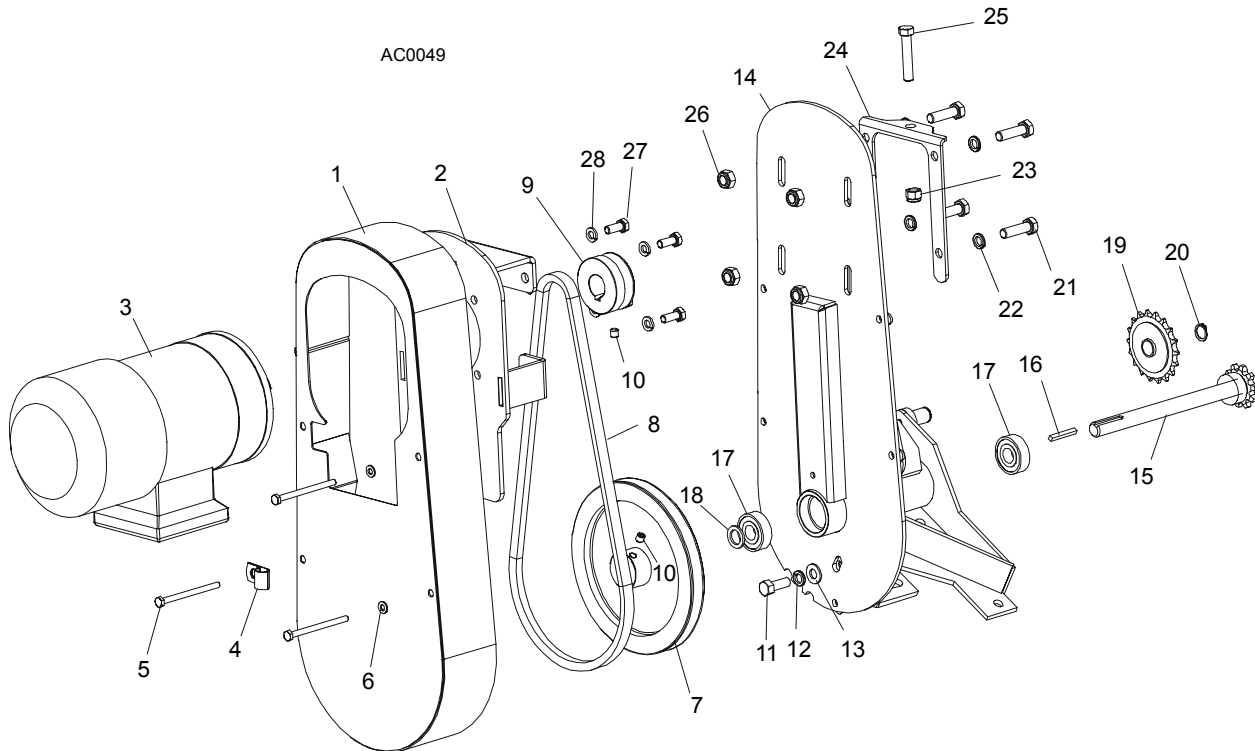

REF	DESCRIPTION (◆ Indicates Parts Available In Assemblies Only)	PART #	QTY.	
	POWER FEED ASSEMBLY, AC SUPER	086522	1	
1	Cover Weldment, Top Power Feed	015128	1	
2	Plate, Power Feed Motor	086390	1	
3	Motor, 1100 W Power Feed Painted, AC Super	086530	1	
4	Clamp, 1/2" EMT Coated	P07584	1	
5	Bolt, M6 x 80 5.8 Hex Head Grade	F81001-61	4	
6	Washer, 6.4 Flat	F81053-1	4	
7	Sheave, Power Feed	086410-1	1	
8	Belt, Power Feed	086532	1	
9	Sheave, Feed Motor	086388-1	1	
10	Screw, M8 X 8-33H Hex Socket Set Flat Point Zinc	F81014-1	2	
11	Bolt, 3/8-16 x 1" Hex Head	F05007-7	1	
12	Washer, 3/8" Split Lock	F05011-4	5	
13	Washer, 3/8" Flat	F05011-3	5	
14	Bracket, Power Feed Mount	015162	1	
15	Shaft Weldment, Power Feed	015129	1	
16	Key, 3/16" Square x 1 3/8" Long	016108	1	
17	Bearing, 6203-2RSP6-5/8 CX	095087	2	
18	Washer, 5/8" x 15/16" x .094" Nylon	F05011-19	1	
19	Sprocket, 40 Idler 18T 5/8" ID	P04333	1	
20	Ring, Z15	F81090-2	1	
21	Bolt, M10x35-8.8 Hex Head Full Thread Zinc	F81003-17	4	
22	Washer, 10.2 Split Lock Zinc	F81055-2	1	◆
23	Nut, 3/8-16 Hex Nylon Lock	F05010-10	1	

24	Bracket, Power Feed Mount	015162-1	1	
25	Bolt, 3/8-16 x 2" Hex Head Full Thread Zinc	F05007-16	1	
26	Nut, M10-8-B Hex Nylon Zinc Lock	F81033-1	1	
27	Bolt, M8x20-8.8-B Hex Head Full Thread Zinc	F81002-4	4	
28	Washer, 8.2 Split Lock Zinc	F81054-4	4	

7.3 Feed Chain/Stop

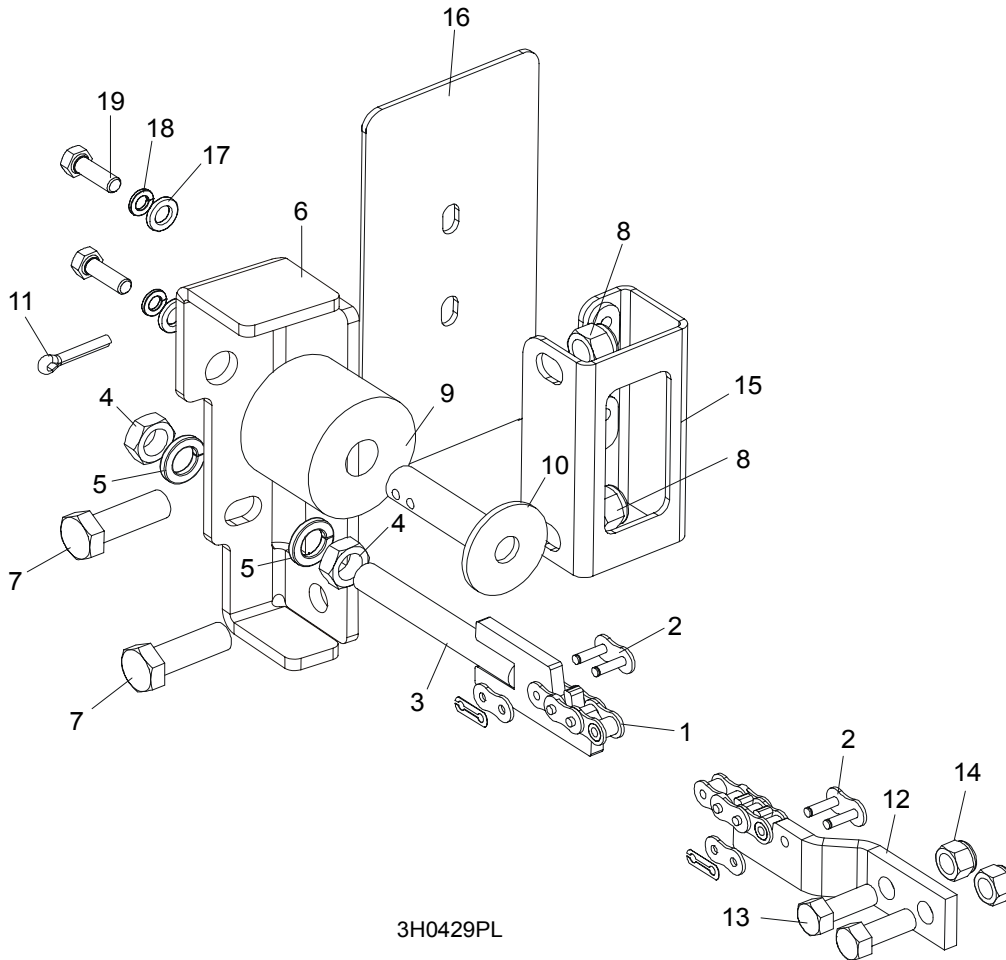

3H0429PL

REF	DESCRIPTION (◆ Indicates Parts Available In Assemblies Only)	PART #	QTY.
	CHAIN KIT, LT30 FEED	K10408	1
	CHAIN KIT, LT40 FEED	K10410	1
1	Chain, #40 X 215" LT30 Feed	014744	1
	Chain, #40 X 267.5" LT40 Feed	014475	1
2	Link, #40 Master	P04200	2
3	Tensioner Weldment, Power Feed Chain	086818-1	1
4	Nut, M12-5 Hex Jam	F81034-4	2
5	Washer, 12.2 Split Lock	F81056-2	2
6	BRACKET, FEED CHAIN REAR MOUNT	087628-1	1
7	BOLT, M12 X 40 8.8 HEX HEAD GRADE 5	F81004-4	2
8	NUT, M12-8 HEX NYLON LOCK	F81034-2	2
	STOP KIT, RUBBER CARRIAGE	K09630	2
9	Stop, Rubber Carriage	P12165	1
10	Pin, Rubber Carriage Stop	W09293	1
11	Pin, 3/16" X 1" Cotter	F05012-21	1
12	BRACKET, FRONT FEED CHAIN MOUNT	095733-1	1
13	BOLT, 3/8-16 X 1" HEX HEAD	F05007-7	2
14	NUT, 3/8-16 HEX NYLON LOCK	F05010-10	2
15	BRACKET WELDMENT, REAR MAIN TUBE COVER MOUNT	087105-1	1

16	COVER, REAR MAIN TUBE	015023	1	
17	WASHER, 8.4 FLAT	F81054-1	2	
18	WASHER, 8.2 SPLIT LOCK	F81054-4	2	
19	BOLT, 5/16-18 X 1" HEX HEAD	F05006-1	2	

7.4 Lower Track Rollers

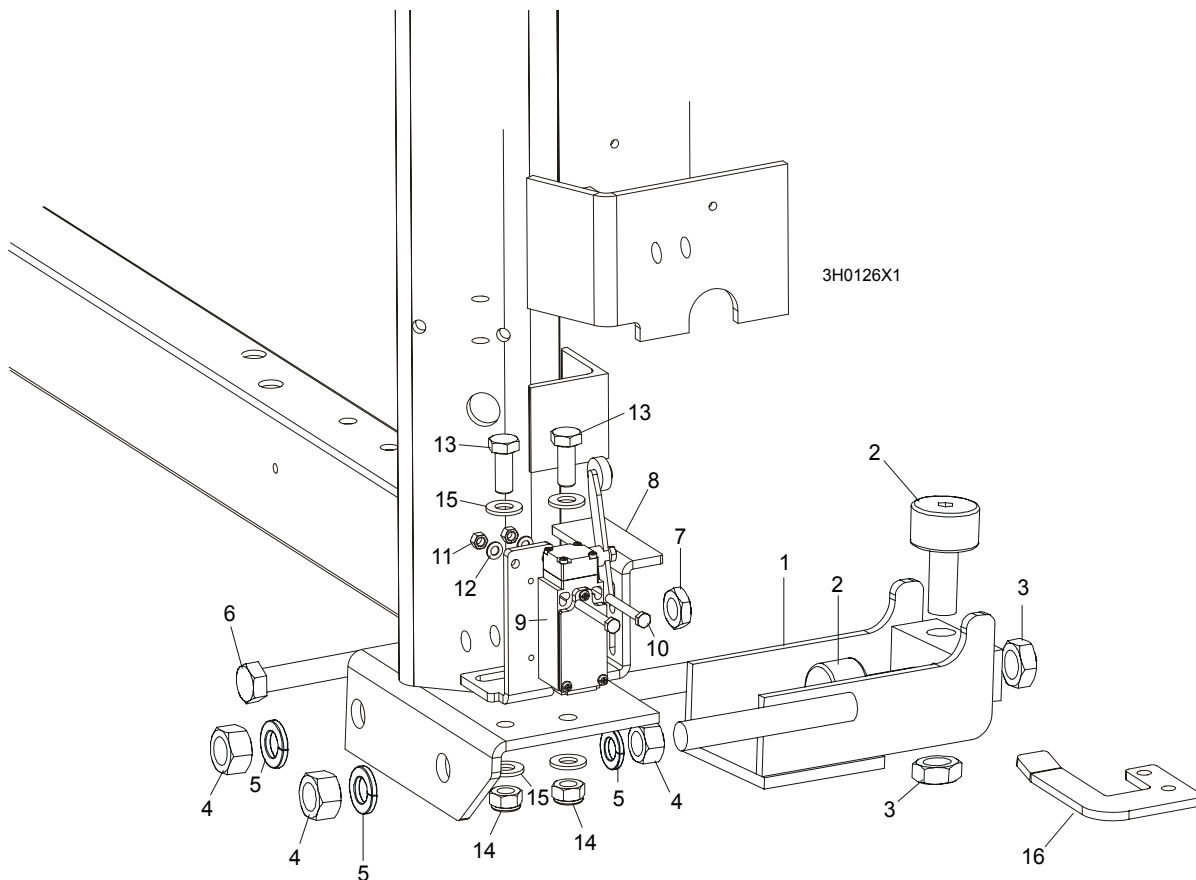

REF	DESCRIPTION (◆ Indicates Parts Available In Assemblies Only)	PART #	QTY.
	ROLLER ASSEMBLY, LOWER TRACK	098741	2
1	Bracket, Lower Track Roller Mounting	098740-1	1
2	Roller, Track Cam Bearing (McGill)	012797	2
3	Nut, 5/8-18 Hex Jam	F05010-11	2
4	Nut, M16, Hexagon, Grade 5.8 Plain	F81036-1	4
5	Washer, 16.3 Split Lock	F81058-2	4
6	BOLT, M12 X 55-8.8 HEX HEAD FULL THREAD	F81004-12	2
7	NUT, M12-8-B HEX JAM	F81034-1	2
8	BRACKET, POWER SUPPLY STRIP AND LIMIT SWITCH	086380-1	1
9	SWITCH, GLCB01A2B LIMIT	086469	1
10	BOLT, M5 X 40 8.8 HEX HEAD	F810000-11	2
11	NUT, M5-8	F81030-1	2
12	WASHER, 5.3 FLAT	F81052-1	2
13	BOLT, M10 X 25 8.8	F81003-11	2
14	NUT, M10 NYLON	F81033-1	2
15	WASHER, 10.5 FLAT	F81055-1	2
16	BRACKET, LIMIT SWITCH	091852-1	1

SECTION 8 BED FRAME ASSEMBLY

8.1 Bed Rail Assembly, Front and Rear

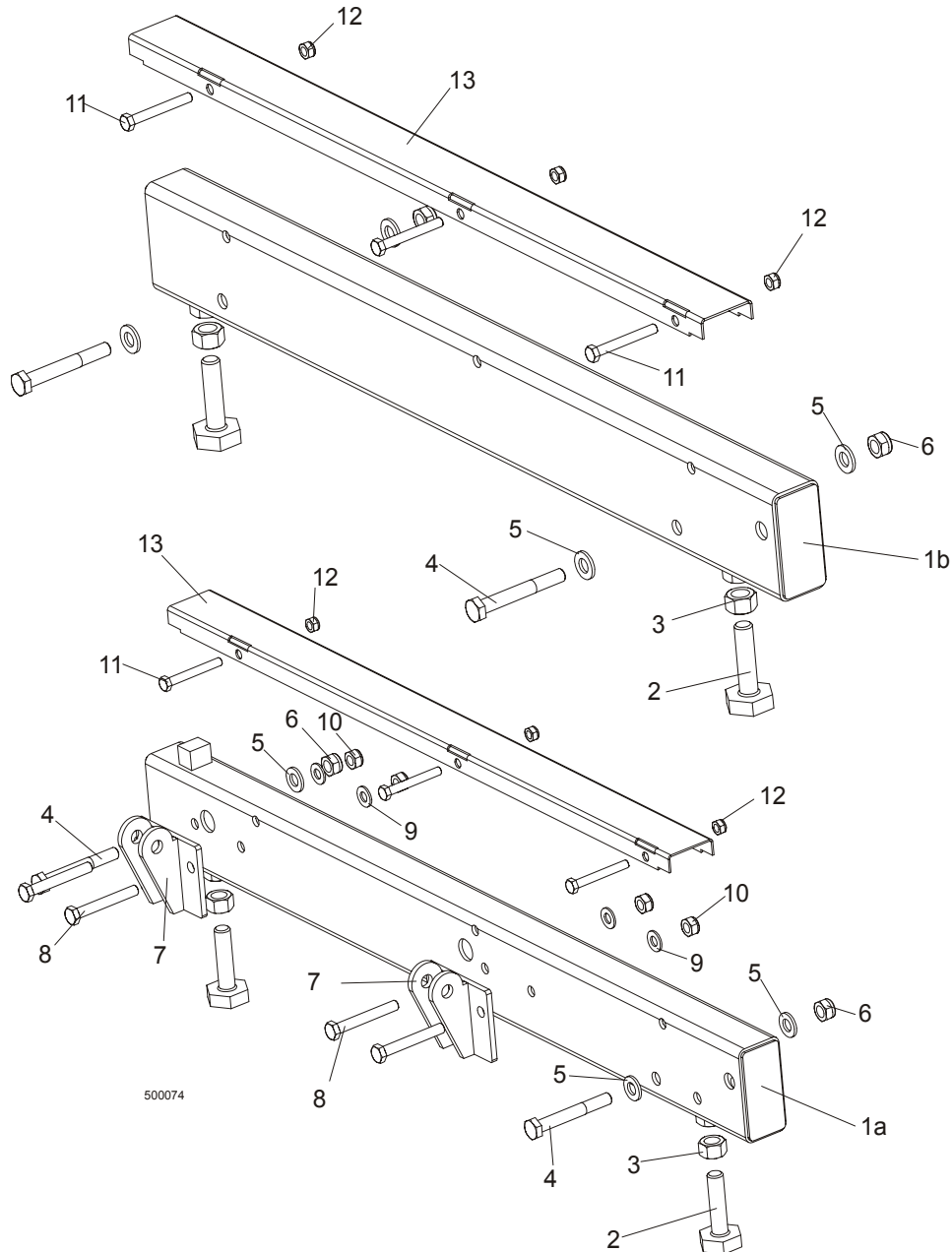

REF	DESCRIPTION (◆ Indicates Parts Available In Assemblies Only)	PART #	QTY.
1a	BED RAIL ASSEMBLY 1, "L" FRAME	100680	1
	Bed Rail Bolt, Complete (M16 Bolt + 2xNut)	093710	1
2	Bolt, M16 Bed Rail Adjustment	086809	1
3	Nut, M16-5-B Hex	F81036-5	2

BED FRAME ASSEMBLY*Bed Rail Assembly, Front and Rear*

	BED RAIL ASSEMBLY, LONG	089385	4	
1a	Bed Rail Tube, Long	087433	1	◆
	Bed Rail Bolt, Complete (M16 Bolt + 2xNut)	093710	1	
2	Bolt, M16 Bed Rail Adjustment	086809	1	
3	Nut, M16-5-B Hex	F81036-5	2	
	BED RAIL ASSEMBLY, POWER ROLLER	095650	1	
1a	Bed Rail Tube, Power Roller	096994	1	◆
	Bed Rail Bolt, Complete (M16 Bolt + 2xNut)	093710	3	
2	Bolt, M16 Bed Rail Adjustment	086809	1	
3	Nut, M16-5-B Hex	F81036-5	2	
	BED RAIL ASSEMBLY, SHORT	089386	2	
1b	Bed Rail Tube, Short	087878	1	◆
	Bed Rail Bolt, Complete (M16 Bolt + 2xNut)	093710	1	
2	Bolt, M16 Bed Rail Adjustment	086809	1	
3	Nut, M16-5-B Hex	F81036-5	2	
4	BOLT, M12x90-8.8 ZINC HEX HEAD	F81004-2	2	
5	WASHER, 13 FLAT ZINC	F81056-1	4	
6	NUT, M12-8 HEX NYLON ZINC LOCK	F81034-2	2	
7	BRACKET, TOE BOARD ROLLER MOUNT	087903-1	2	
8	BOLT, M10x75-8.8 ZINC HEX HEAD	F81003-15	4	
9	WASHER, 10.5 FLAT ZINC	F81055-1	4	
10	NUT, M10-8-B HEX NYLON ZINC LOCK	F81033-1	4	
11	BOLT, M8 x 65-5.8 ZINC HEX HEAD	F81002-3	3	
12	NUT, M8-8-B HEX NYLON ZINC LOCK	F81032-2	3	
13	COVER, STAINLESS STEEL BED RAIL	099124	1	

8.2 Leg, Stationary

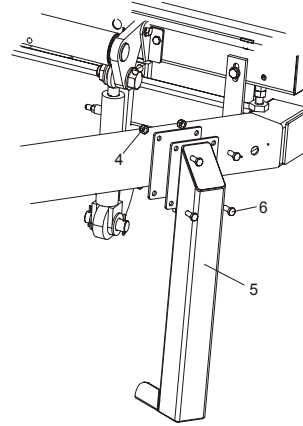
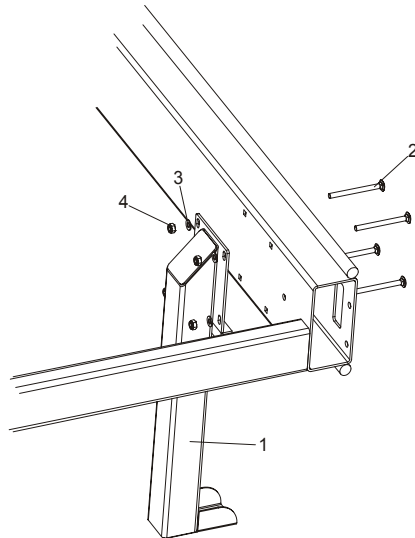
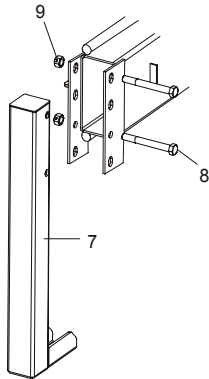

500082

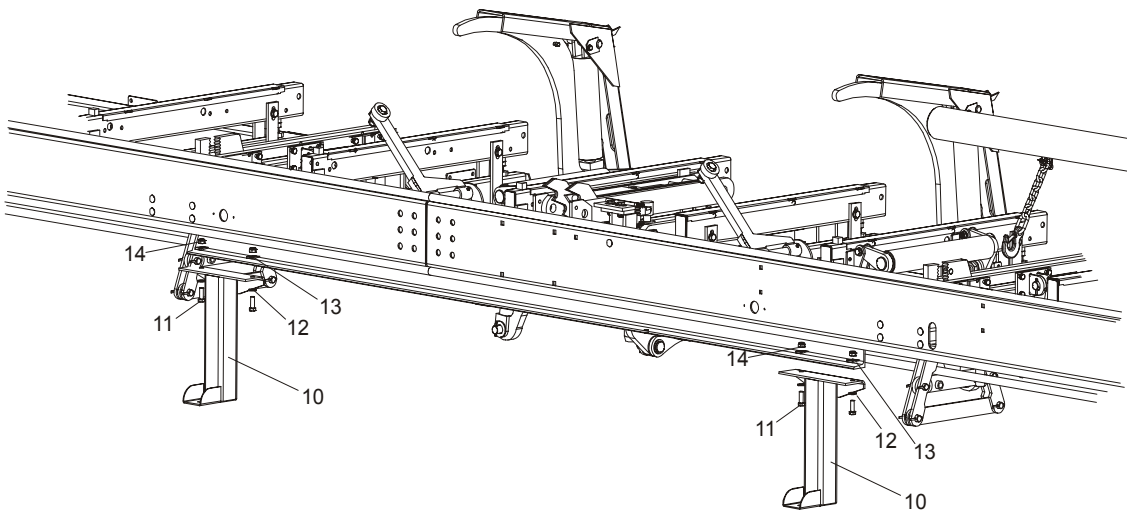

REF	DESCRIPTION (◆ Indicates Parts Available In Assemblies Only)	PART #	QTY.
1	LEG, LONG STATIONARY	087451-1	1
2	BOLT, M10X120 8.8 ZINC MUSHROOM HEAD SQUARE NECK	F81003-33	4
3	WASHER, 10.5 FLAT ZINC	F81055-1	4
4	NUT, M10-8-B HEX NYLON ZINC LOCK	F81033-1	32
5	LEG, LEFT STATIONARY	087450-1	7

6	BOLT, M10X25-8.8 ZINC HEX HEAD	F81003-11	28	
7	LEG, FRONT STATIONARY	087452-1	1	
8	BOLT, M16 X 140 - 8.8 HEX HEAD	F81006-4	2	
9	NUT, M16-8 HEX NYLON LOCK	F81036-2	2	
10	LEG, MIDDLE STATIONARY	087093-1	2	
11	BOLT, M12X35-8.8	F81004-24	4	
12	WASHER, 13 FE/ZN5	F81056-1	4	
13	WASHER, 14 SQUARE TAPER	F81055-13	4	
14	NUT, M12-8 HEX NYLON ZINC LOCK	F81034-2	4	

8.3 Pivot Bed Rail Assembly

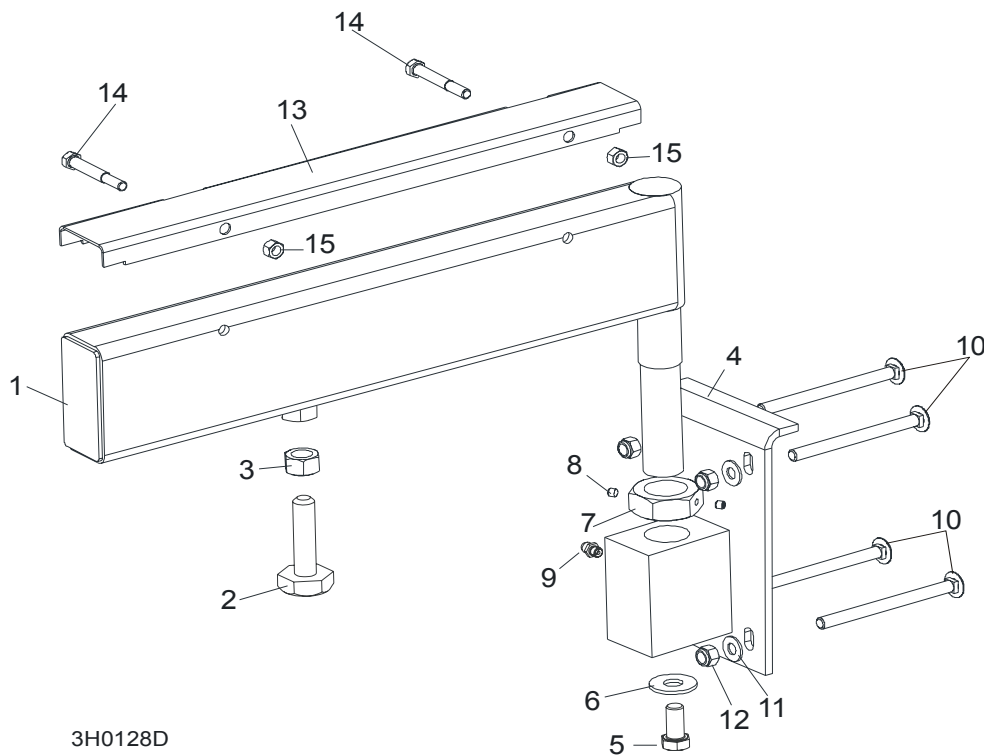

REF	DESCRIPTION (◆ Indicates Parts Available In Assemblies Only)	PART#	QTY.	
	PIVOT BED RAIL, COMPLETE	087855	2	
1	Pivot Bed Rail Assembly	087848-1	1	
	Bolt Assembly, Bed Rail Adjustment		1	
2	Bolt, Pivot Bed Rail Adjustment	086809	1	
3	Nut, M16-5.8 Zinc Hex	F81036-1	1	
4	Bracket, Pivot Bed Rail Mounting	087841-1	1	
5	Bolt, M12x25-8.8 Hex Head Full Thread Zinc	F81004-31	1	
6	Washer, 9/16" Zinc Flat	F05011-52	1	
7	Nut, M32x2-04-B Zinc	087975	1	

8	Screw, M6x8 Hex Socket Set Cone Point Zinc	F81013-1	2	
9	Fitting, 3/16" Straight Grease	086280	1	
10	BOLT, M10X125 8.8 MUSHROOM HEAD SQUARE NECK ZINC	F81003-34	4	
11	WASHER, 10.5 FLAT	F81055-1	8	
12	NUT, M16-8 HEX NYLON ZINC LOCK	F81036-2	8	
	COVER KIT, STAINLESS STEEL PIVOT BED RAIL	N/A	2	
13	Cover, Pivot Bed Rail	099123	1	
14	Bolt, M8x65-5.8 Hex Head Zinc	F81002-3	2	
15	Nut, M8-8-B Hex Nylon Zinc Lock	F81032-2	2	
	WRENCH, BED RAIL ADJUSTMENT (Patrz rozdział 8.3)	015970	1	

8.4 Log Side Support Assembly (Manual)

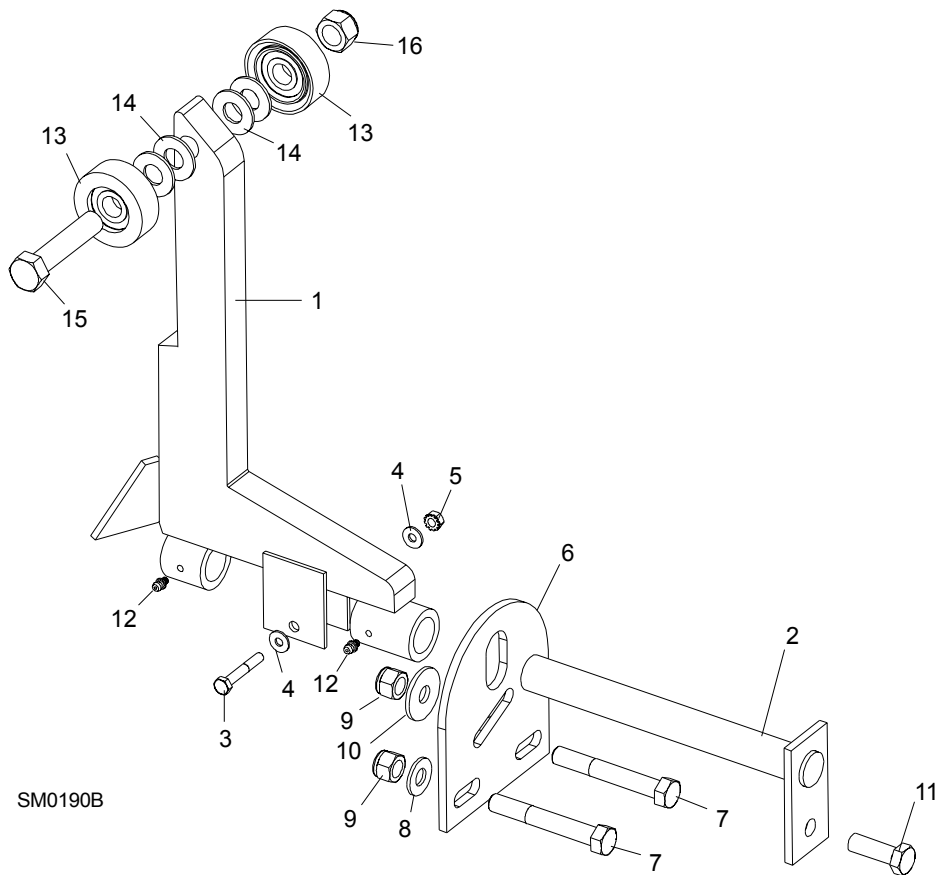

REF	DESCRIPTION (◆ Indicates Parts Available In Assemblies Only)	PART #	QTY.	
1	SUPPORT, LOG SIDE W/GUARD	099785-1	1	
2	PIN, LOG SIDE SUPPORT PIVOT	091549-1	1	
3	BOLT, M8X45 - 8.8 HEX HEAD GRADE 5	F81002-14	1	
4	WASHER, 8.4 FLAT	F81054-1	2	
5	NUT, M8-8-B SELF LOCKING	F81032-2	1	
6	PLATE, LOG SIDE SUPPORT END	091591-1	1	

8

BED FRAME ASSEMBLY

Bed Frame Decals

7	BOLT, M12 X 90-8.8 HEX HEAD	F81004-2	2	
8	WASHER, 13 FLAT	F81056-1	2	
9	NUT, M12-8 HEX NYLON LOCK	F81034-2	3	
10	WASHER, .5" X 1.63" X 11" GA.	086184	1	
11	BOLT, M12 X 35-8.8 HEX HEAD	F81004-24	1	
12	FITTING, 3/16" GREASE	P04107	2	
13	ROLLER ASSEMBLY, SIDE SUPPORT	015014-1	2	
14	WASHER, 17 FLAT	F81058-1	2	
15	BOLT, M16X65-8.8-B HEX HEAD GRADE 5	F81006-1	1	
16	NUT, M16-8 NYLON LOCK	F81036-2	1	
	INSTRUCTION SHEET, SIDE SUPPORT ROLLER	015109-526	1	

8.5 Bed Frame Decals

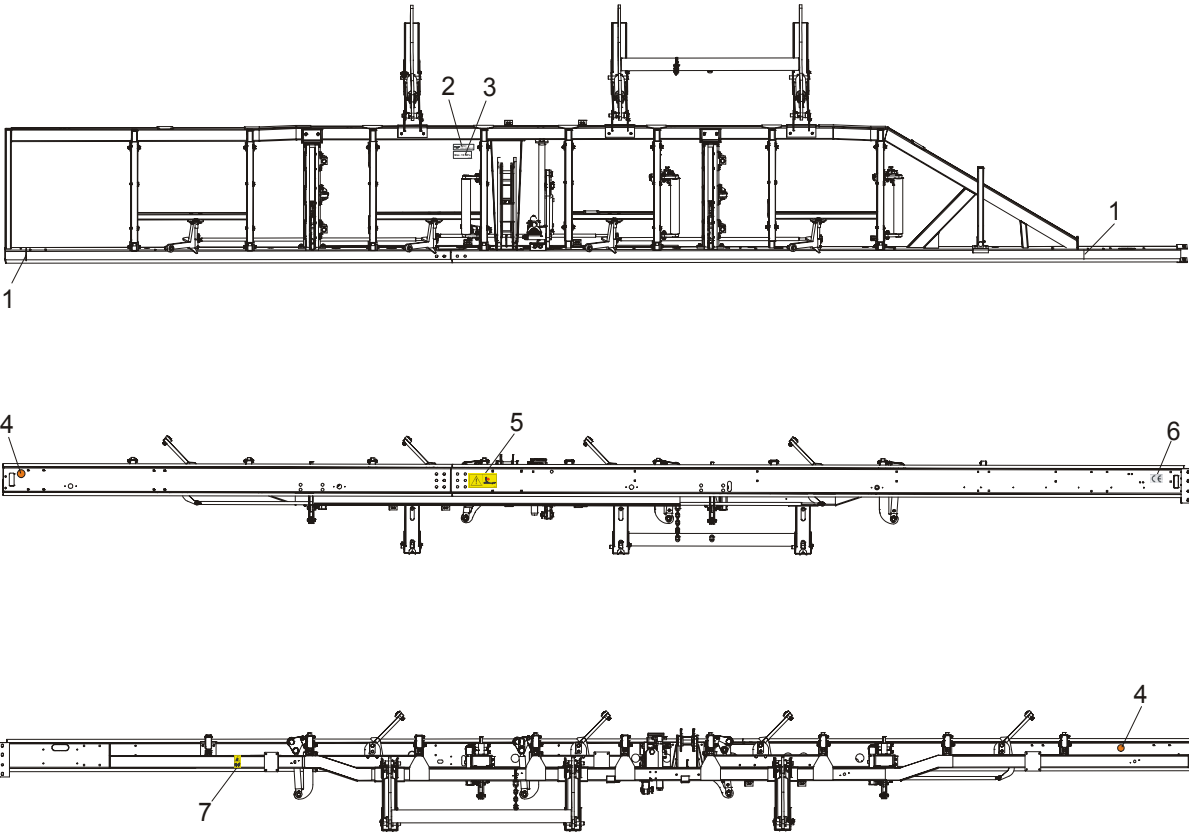

REF	DESCRIPTION (◆ Indicates Parts Available In Assemblies Only)	PART #	QTY.	
1	DECAL, LOG LENGTH LIMIT	S12051	2	
2	DECAL, HYDRAULIC OIL TYPE	096323	1	
3	DECAL, HYDRAULIC WORKING PRESSURE	099524	1	
4	DECAL, AMBER REFLECTIVE 2" ROUND	P07453	2	
5	DECAL, PINCH POINT DANGER, PICTOGRAM	099542	1	

6	DECAL, CE CERTIFIED SAWMILL, SMALL	P85070	1	
7	DECAL, KEEP AWAY DANGER, PICTOGRAM	099221	1	

8.6 LT70 L Saw Head Support Assembly

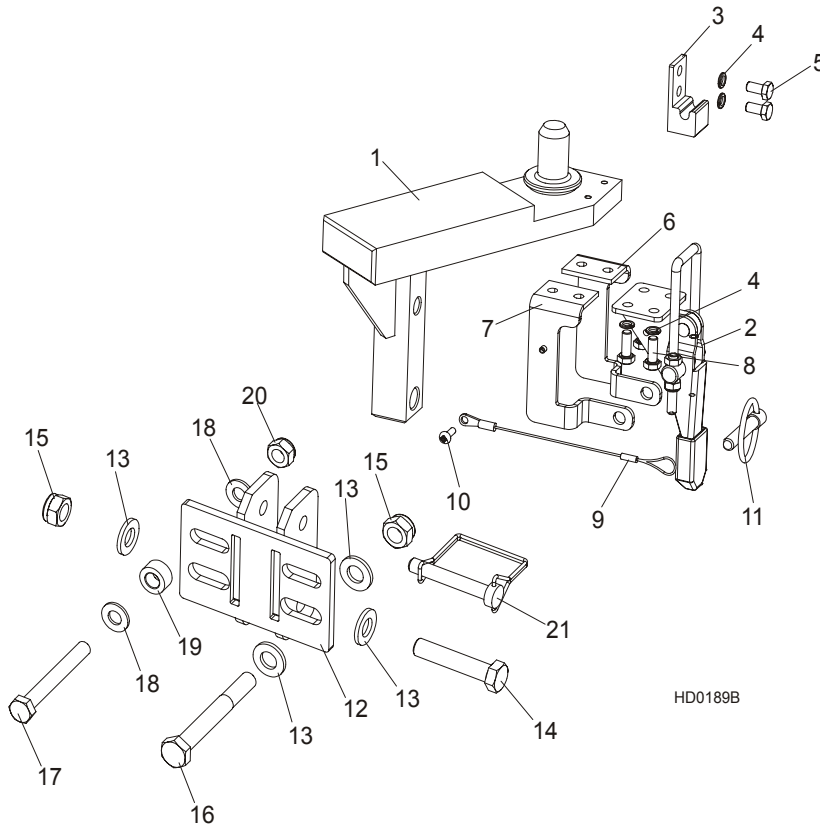

L.P.	OPIS (◆ wskazuje części dostępne jedynie w zespołach)	NUMER KAT.	SZT.	
	SAW HEAD REST PIN W/LATCH CLAMP, LT70L	094657	1	
1	Pin Weldment, LT70L Saw Head Rest	094655-1	1	
2	Clamp, GN851.2-320-T4 Latch	094656	1	
3	Latch Bracket, GN851.2-320-T4 Zinc-plated	094659-1	1	
4	Washer, Z 6.1 Split Lock Zinc	F81053-3	6	
5	Bolt, M6x12-8.8 Hex Head Full Thread Zinc	F81001-7	6	
6	Bracket, Locking Right	097102-1	1	
7	Bracket, Locking Left	097103-1	1	
8	Bolt, M6x16-8.8-Fe/Zn5 PN-85/M-82105	F81001-32	4	
9	Lanyard, 3/64x6"	016030	1	
10	Screw, M4x12 -5,8-B- Fe/Zn5 PN-M/82202	F81011-43	1	
11	Pin, 8 BN914 (BOSSARD 1364650) Clamp Lock	F81046-2	1	
12	BRACKET, LT40 SAW HEAD REST PIN MOUNT PAINTED	092765-1	1	
13	WASHER, 13 FLAT ZINC	F81056-1	4	
14	BOLT, M12 X 60-8.8 HEX HEAD ZINC	F81004-5	1	

8 BED FRAME ASSEMBLY

Tie Down Chain Assembly

15	NUT, M12-8 HEX NYLON ZINC LOCK	F81034-2	2	
16	BOLT, M12x95-8.8 HEX HEAD ZINC	F81004-29	1	
17	BOLT, M10x80-8.8 HEX HEAD ZINC	F81003-50	1	
18	WASHER, 10.5 FLAT ZINC	F81055-1	2	
19	BUSHING, ZINC-PLATED SPACER	090936-1	1	
20	NUT, M10-8-B HEX NYLON ZINC LOCK	F81033-1	1	
21	PIN, 3/8" X 2 1/4" SNAP RETAINER	014151	1	

8.7 Tie Down Chain Assembly

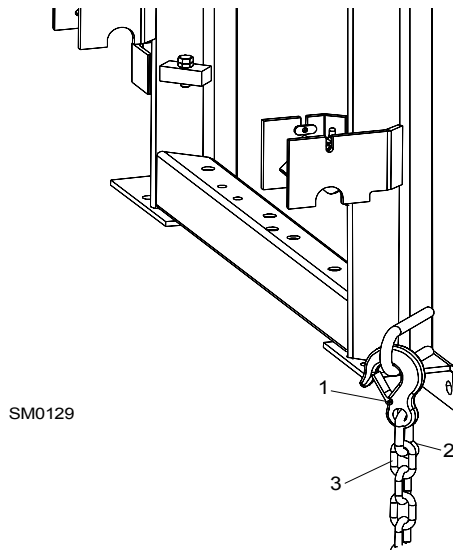

REF	DESCRIPTION (◆ Indicates Parts Available In Assemblies Only)	PART #	QTY.	
	CHAIN ASSEMBLY, TIE DOWN	A04376-1	1	
1	Hook, 5/8" Safety Chain	P12075	1	
2	Screw Closed Chain Link, 10	100767	1	
3	Chain, N-10 x 35, 6 Links	100951	1	

SECTION 9 HYDRAULIC SYSTEM

9.1 Hydraulic Hoses, LT40/70L AH

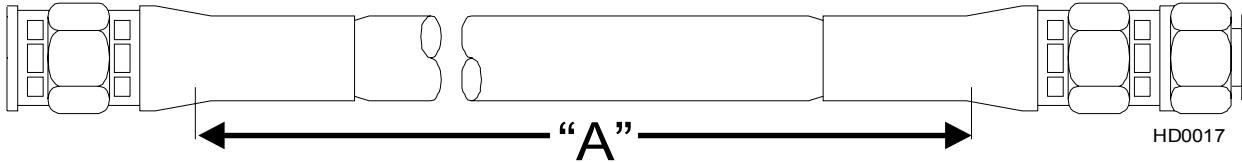

COLOR CODE	LENGT H (m)	DESCRIPTION (◆ Indicates Parts Available In Assemblies Only)	PART #	QTY.
NONE	0,35	3/8" HYDRAULIC PUMP TO HYDRAULIC VALVE	089809	1
NONE	0,65	3/8" VALVE TO VALVE	089844	1
RED	0,43	3/8" SECTION TO OIL FLOW DIVIDER	089845	1
ORANGE	2,80	3/8" MIDDLE LOG CLAMP, IN/OUT CYLINDER (CLAMP OUT)	089846	1
WHITE	3,00	3/8" MIDDLE LOG CLAMP, IN/OUT CYLINDER (CLAMP IN)	089847	1
NONE/PINK	5,40	3/8" HYDRAULIC VALVE TO LOG SIDE SUPPORT CYLINDER	089848	2
BROWN/LILAC	4,10	3/8" LOG SIDE SUPPORT VALVE TO LOG TURNER	089849	2
YELLOW	1,80	3/8" 3RD LOG LOADER CYLINDER (SINGLE LOADING ARM) BOTTOM TO OIL FLOW DIVIDER	089850	1
BLUE	0,72	3/8" HYDRAULIC VALVE TO 1ST TEE CONNECTOR (NEXT TO LOG TURNER)	089851	1
GREEN/YEL- LOW GREEN	1,20	3/8" 3RD TEE CONNECTOR TO 2ND LOG LOADER CYLINDER TOP/BOTTOM 3/8" 1ST TEE CONNECTOR TO 3RD LOG LOADER CYLINDER TOP	089852	3
RED	2,00	3/8" OIL FLOW DIVIDER TO 2ND TEE CONNECTOR	089853	1
YELLOW	2,10	3/8" 2ND TEE CONNECTOR TO 1ST LOG LOADER CYLINDER BOTTOM	089854	1
BLUE	1,60	3/8" 1ST TEE CONNECTOR TO 3RD TEE CONNECTOR	089855	1
GREEN	1,90	3/8" 3RD TEE CONNECTOR TO 1ST LOG LOADER CYLINDER TOP	089856	1
LILAC/BLACK	2,55	1/4" 3RD TOE BOARD	089859	2
LILAC/BLACK	0,85	1/4" 2ND TOE BOARD	089860	2
BROWN/SIL- VER	4,10	1/4" 1ST TOE BOARD	089861	2
YELLOW	3,85	1/4" MIDDLE LOG CLAMP, UP/DOWN CYLINDER BOTTOM	089862	1
GREEN	3,95	1/4" MIDDLE LOG CLAMP, UP/DOWN CYLINDER TOP	089863	1
ORANGE	4,20	1/4" 1ST LOG CLAMP IN/OUT (CLAMP OUT)	089864	1
WHITE	4,40	1/4" 1ST LOG CLAMP IN/OUT (CLAMP IN)	089865	1
BLUE/RED	4,90	1/4" 1ST LOG CLAMP UP/DOWN	089866	2
WHITE/ORAN GE	2,70	1/4" 3RD LOG CLAMP IN/OUT	089867	2
BLUE/RED	0,60	1/4" 3RD LOG CLAMP UP/DOWN	089868	2

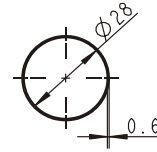
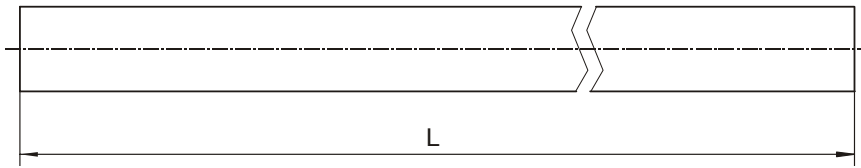
Protective Conduits, LT70 Series A/DH Hydraulic Hoses

LENGTH "L"	DESCRIPTION (◆ Indicates Parts Available In Assemblies Only)	PART #	QTY.
0,70	PROTECTIVE CONDUIT, LOG TURNER HOSE	099761	2
0,28	PROTECTIVE CONDUIT, IN/OUT CYLINDER HOSE - BOTTOM	099762	1
0,45	PROTECTIVE CONDUIT, IN/OUT CYLINDER HOSE - TOP	099763	1
1,35	PROTECTIVE CONDUIT, UP/DOWN CYLINDER HOSE - BOTTOM	099764	1
1,65	PROTECTIVE CONDUIT, UP/DOWN CYLINDER HOSE - TOP	099765	1

9.2 Hydraulic Control Box, LT40/70 AH15/14

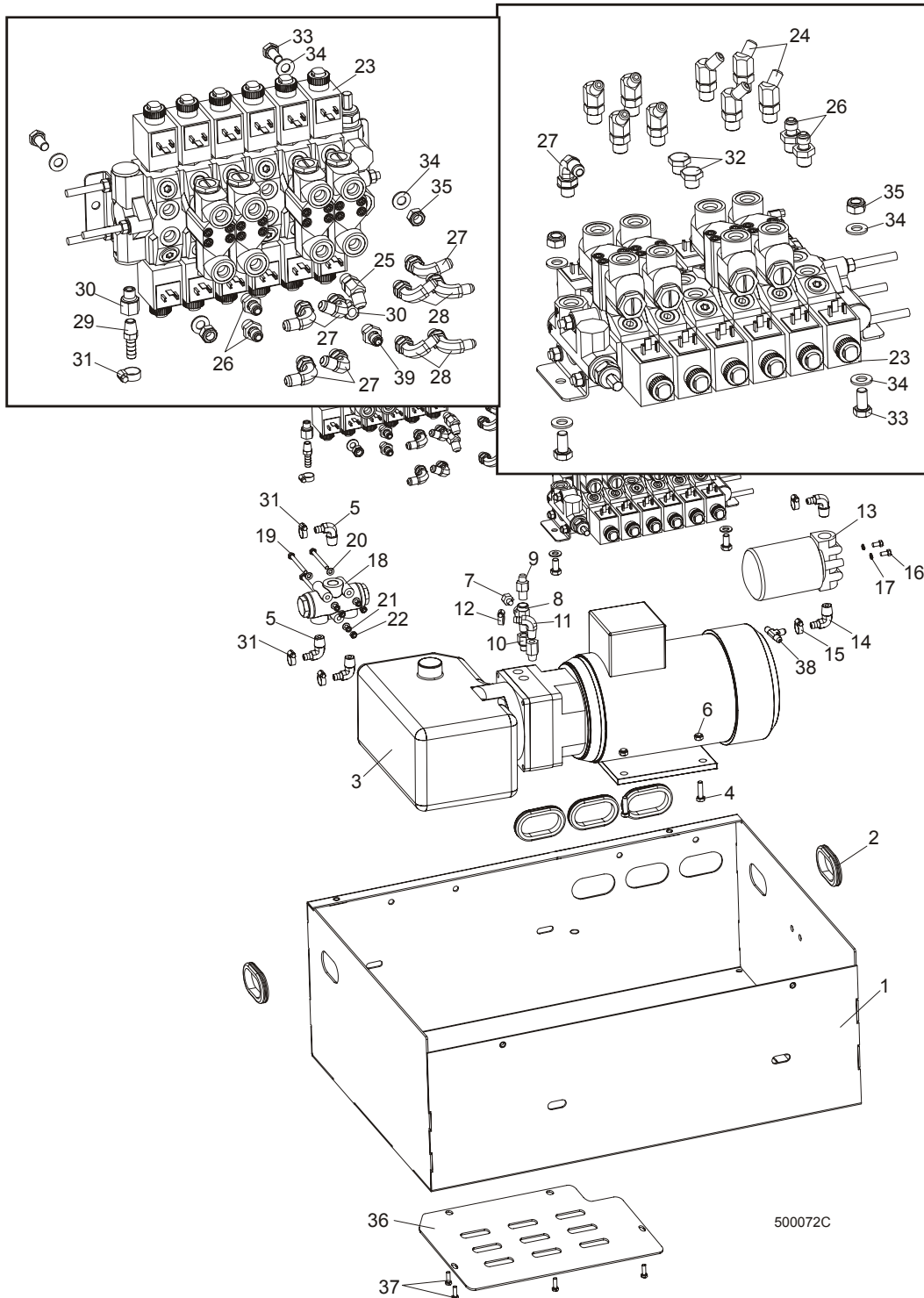

REF	DESCRIPTION (◆ Indicates Parts Available In Assemblies Only)	PART #	QTY.
	HYDRAULIC CONTROL BOX, LT40/70 AH15	093732 ¹	1
	HYDRAULIC CONTROL BOX, LT40/70 AH14	093734	1
	HYDRAULIC CONTROL BOX, LT40/70 AH13	093736	1
1	Box Weldment, 9.5 M AC Hydraulic Control	089636-1	1
2	Grommet, FM54 Rubber	087065	5
3	HYDRAULIC PUMP W/MOTOR, 4KW 14.5 L/MIN. AC	500958	1

4	Bolt, M8X25-8.8-B Zinc Hex Head	F81002-5	4	
5	Fitting, 90 18x1,5 9/16-18 JIC Elbow	089992	3	
6	Nut, M8-8-B Zinc Hex Nylon Lock	F81032-2	4	
7	Plug, 1/4" NPT Blank	096221	1	
8	Fitting, C3759X4 Tee Connector	P09141	1	
9	Fitting, 1/4" NPT - 1/4" NPT Male	P09143	1	
10	Fitting, #6SEA MALE - 1/4NPT Female	014686	1	
11	Fitting, #6-6 (3/8" NPT) - 3/8" Elbow	P12708	1	
12	Clamp, 11/16 Hose	P12739	1	
13	BRANCH-JOINT, HYDRAULIC WITH 1.2" FILTER	P22683	1	
14	Fitting, 1/2" NPT - 3/8" Elbow	P12707	2	
15	Clamp, 11/16 Hose	P12739	4	
16	Bolt, 1/4-20 X 1/2" Zinc Hex Head Grade 2	F05005-15	2	
17	Washer, Z 6.1 Split Lock Zinc	F81053-3	2	
18	DIVIDER, MTD A 08-016M 1/3 / 2/3 OIL FLOW	088190 ²	1	
19	Bolt, M6X65-8.8 Zinc Hex Head	F81001-81	3	
20	Washer, 6.4 FLAT ZINC	F81053-1	6	
21	Washer, Z 6.1 Split Lock Zinc	F81053-3	2	
22	Nut, M6-8-B Hex Nylon Lock Zinc	F81031-2	3	
23	HYDRAULIC VALVE, HDS11 6K01-151/MOD 6/062Z0 HYDRAULIC VALVE, HDS11 6K01-151/MOD 6/063Z0	088188 088189	1 1	
24	Fitting, #4 SAE - #6 SAE 45° Elbow	015488	8	
25	Fitting, #6 SAE 45° Elbow 45ST #6SAE	015489	1	
26	Fitting, 3/8" O-ring - 1/4" JIC	P26284	4/2	
27	Fitting, #6 SAE 3/8" JIC Elbow	P12704	6	
28	Fitting, 90 9/16-18 JIC 7/16-20 JIC Elbow	089642	4	
29	Fitting, L" NPT X 3/8" Hose Barb	014685	2	
30	Fitting, #6SEA MALE - 1/4NPT Female	014686	2	
31	Clamp, 11/16 Hose	P12739	2/4	
32	Plug, 9/16-18 JIC Hydraulic Valve	089647	2	
33	Bolt, M10X20-5.8 Zinc Hex Head	F81003-1	4	
34	Washer, 10.5 Flat Zinc	F81055-1	8	
35	Nut, M10-8-B Hex Nylon Lock Zinc	F81033-1	4	
36	COVER WELDMENT, LT80 HYDRAULIC BOX BOTTOM PAINTED	090962-1	1	
37	BOLT, M6x16 8.8 ZINC HEX HEAD	F81001-15	4	
38	FITTING, 3/8 BARB TEE	015485	1	
39	FITTING, 3/8JIC-1/4NPT STRAIGHT	015560	1	
	MATRIX, DIODE HYDRAULIC	096963	2	

¹ Depending on type of sawmill.

² Not included with AH14 hydraulic kit.

9.3 Hydraulic Control Box

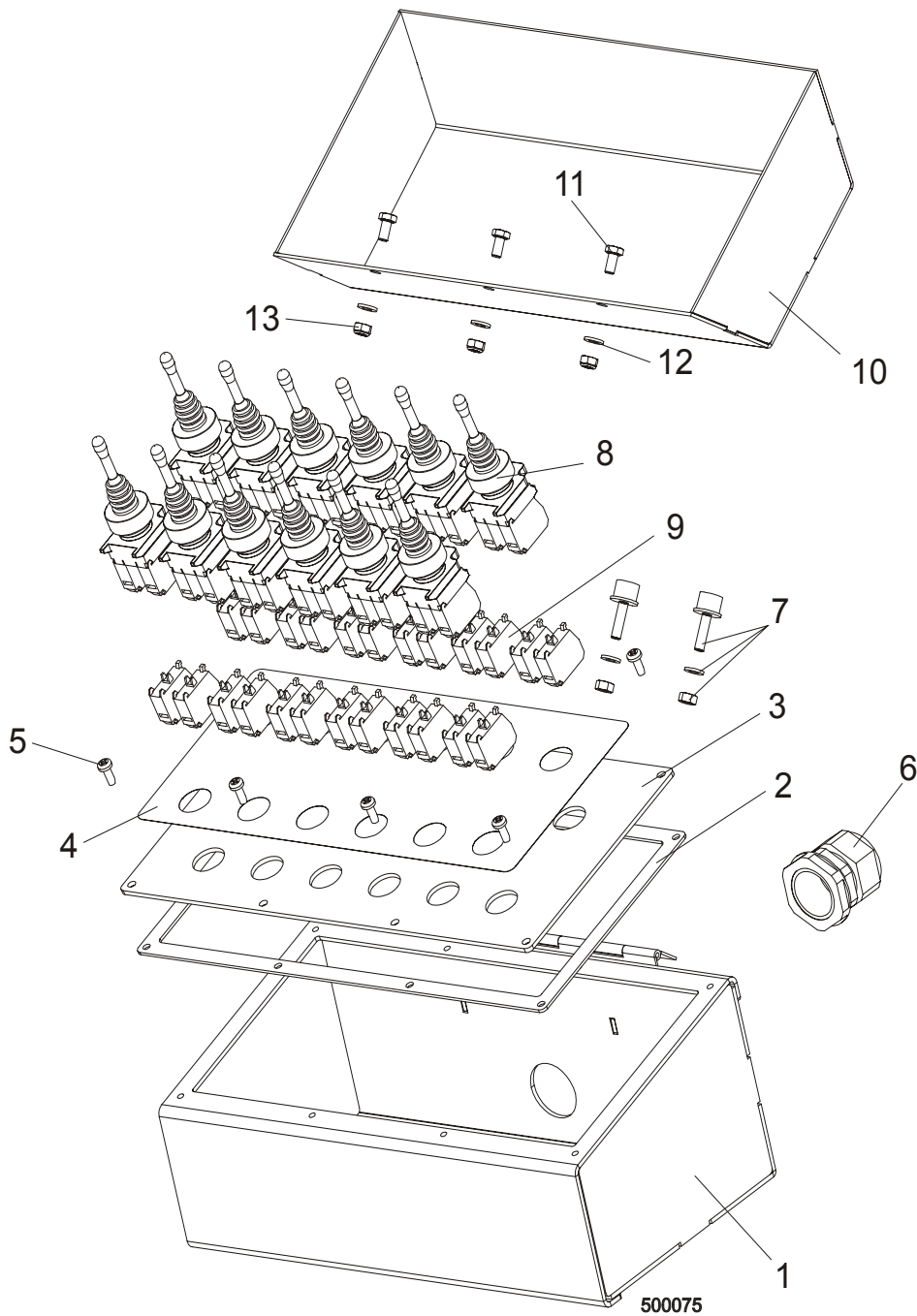

REF	DESCRIPTION (◆ Indicates Parts Available In Assemblies Only)	PART #	QTY.
	BOX, 9.5 M FRAME HYDRAULIC CONTROL	088164	1
1	Box Weldment, Hydraulic Control	088163-1	1
2	Gasket, 9.5 m Frame	089998	1
3	Panel, Hydraulic Control Box Front 9.5 m	089997-1	1
4	Decal, Hydraulic Control Box (9 m Frame)	088159	1
5	Screw, #10-24 x 1/2 Pan Head	F05015-17	8
6	Seal, DP 29/H Gland	F81096-1	1
7	Bumper, A/022 Rubber	088376	2
8	Joystick, PMJN8T3	096928	12
9	Contact, 1NO PL004002	096929	24
10	Cover, Hydraulic Control Box (9.5 m Frame)	088172-1	1

11	Bolt, M6X12-8.8 Zinc Hex Head	F81001-7	3	
12	Washer, 6.4 Flat Zinc	F81053-1	3	
13	Nut, M6-8-B Hex Nylon Lock Zinc	F81031-2	3	

9.4 Hydraulic Power Supply Strip

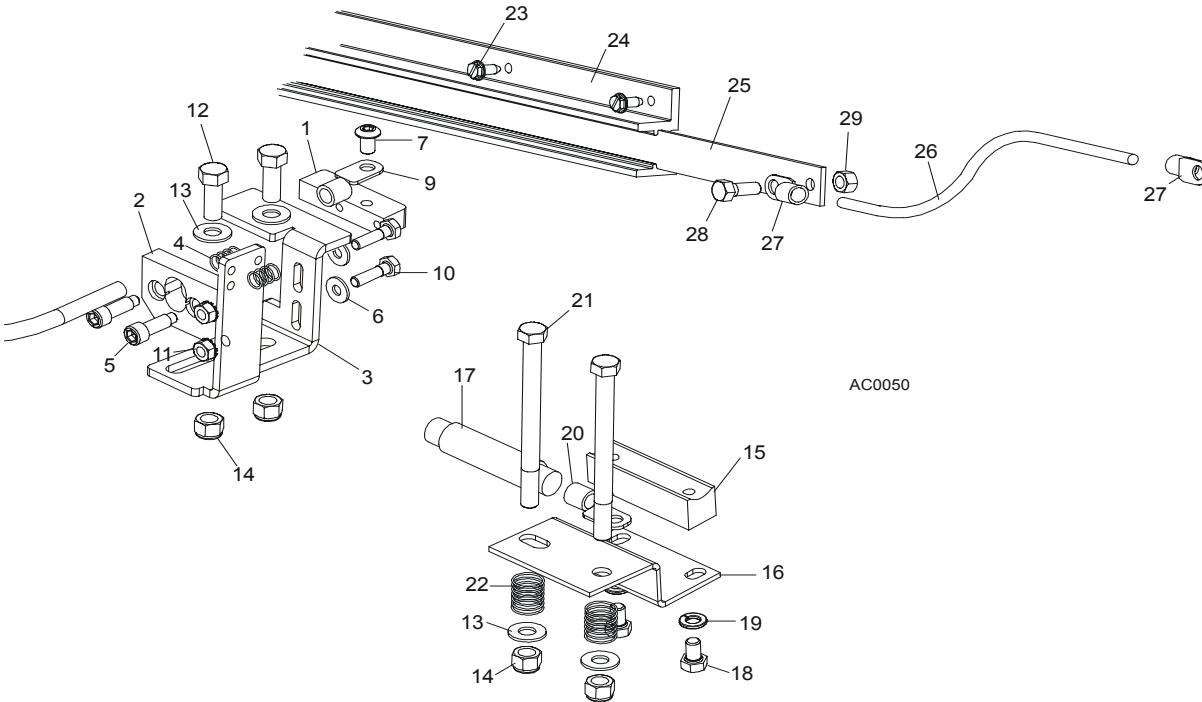

REF	DESCRIPTION (◆ Indicates Parts Available In Assemblies Only)	PART #	QTY.	
	CONTACT KIT, HYDRAULIC 6' POWER SUPPLY	A12042-N	1	
	Contact Hardware Kit	A10073-N	1	◆
	Contact Assembly, Hydraulic Power Supply (Positive)	085968	1	
1	Contact, Hydraulic Power Supply (Positive)	015253	1	
2	Insulator, Positive Contact	S10072	1	
3	Bracket, Positive Contact Mounting	086380-1	1	
4	Spring, Positive Contact	P10077	2	
5	Bolt, 5/16" X 3/4" Shoulder (1/4-20 Thread)	F05006-44	2	
6	Washer, 7.4 Flat	F81056-11	2	
7	Bolt, 5/16-18 x 1/2" Socket Button Head	F05006-20	1	
8	Cable Assy, Hydraulic Positive Contact	015885	1	
8	Cable, #1 Weld	R01948	0.75m	◆
9	Terminal, 35 Ring #2 Gauge	F81066-3	2	
10	Bolt, 1/4-20 X 1" Hex Head Grade 2	F05005-38	2	
11	Nut, 1/4-20 Hex Self-Locking	F05010-9	2	
12	Bolt, 3/8-16 X 1" Hex Head Grade 5	F05007-87	2	
13	Washer, 10.5 Flat	F81055-1	4	
14	Nut, 3/8-16 Hex Nylon Lock	F05010-10	4	
	Contact Assembly, Hydraulic Power Supply (Ground)	A10066	1	
15	Contact, Hydraulic Power Supply (Ground)	015264	1	
16	Bracket, Ground Contact Mounting	015265	1	
17	Cable, #1 Weld	R01948	.63m	◆
18	Bolt, 5/16-18 X 1/2" Hex Head Grade 5	F05006-15	2	

19	Washer, 8.2 Split Lock	F81054-4	2	
20	Terminal, 35 Ring #2 Gauge	F81066-3	1	
21	Bolt, 3/8-16 X 4 1/2" Hex Head Grade 2	F05007-35	2	
22	Spring, Ground Contact	P04282	2	
23	Screw, 1/4-20 X 1/2" Slotted Hex Head	F05015-1	14	
	Strip Assembly, 6' Hydraulic Power Supply w/3 ft. Cable	A11977	1	
24	Housing, 6' Contact Strip	P11976	1	
	Strip, 6' Contact With Cable	A12043-N	1	
25	Strip, 6' Contact	S10075	1	◆
26	Cable, #2 Weld	R80583-21		◆
27	Terminal, 35 Ring #2 Gauge	F81066-3	2	
28	Bolt, 5/16-18 X 3/4" Hex Head Black Nylon	F05006-45	1	
29	Nut, 5/16-18 Hex Black Nylon	F05010-86	1	
	Tube, 5/8" Heat Shrink	R01950-5	.03m	◆
	Grommet, 5/8" Wire	P04137	1	

9.5 Hydraulic Log Loader

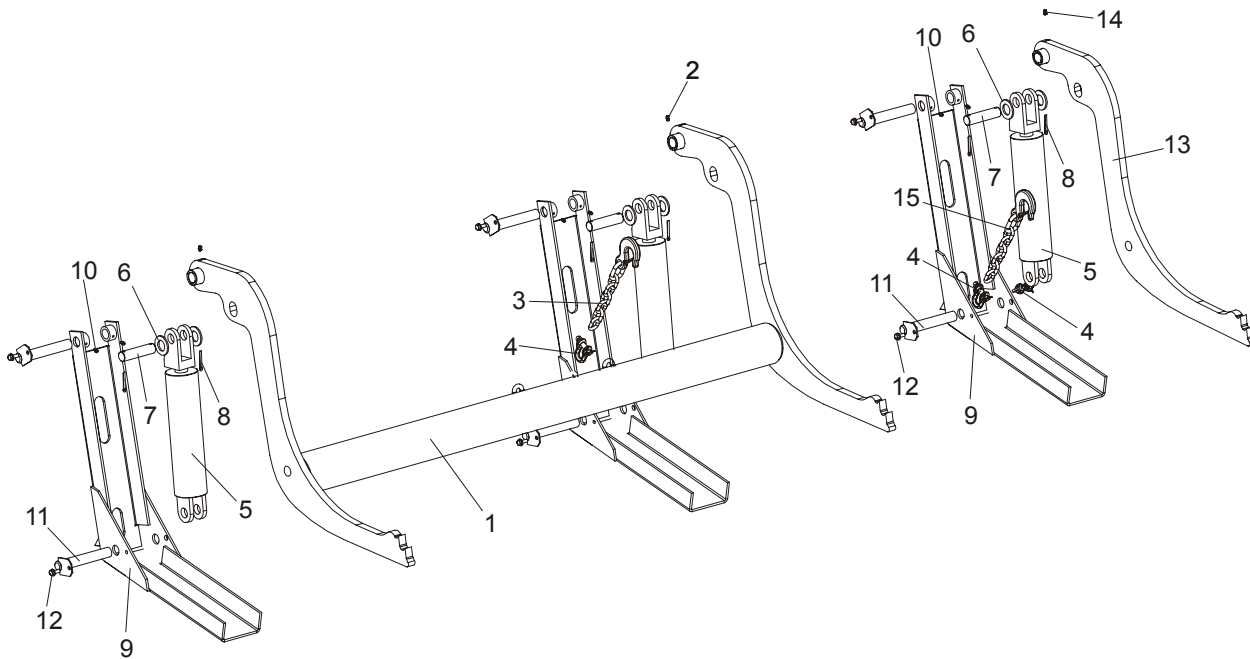

REF	DESCRIPTION (◆ Indicates Parts Available In Assemblies Only)	PART #	QTY.
	HYDRAULIC LOG LOADER, COMPLETE	090044	1
1	Log Loader	090006-1	1
2	Fitting, 3/16" Straight Grease	P04107	2
3	CHAIN, LOG LOADER SAFETY	A04376-1	1
4	SHACKLE, M-D .63	086540	2
5	CYLINDER, CJ-S95-16-70/32/203 HYDRAULIC	088680	3
6	WASHER, 28 FLAT ZINC	F81061-1	6
7	PIN, LOADING ARM CYLINDER MOUNT ZINC	086979-1	3
8	PIN, S-Zn 5x40 COTTER	F81043-31	6
9	Foot, Log Loader	090048-1	3
10	Fitting, 3/16" Straight Grease	P04107	6
11	PIN, LOADER FOOT MOUNT	099127-1	6

12	SCREW, 5/16-18 x 3/4 SELF-TAPPING	F05015-30	6	
	ARM, LOG LOADING SINGLE - COMPLETE	090051	1	
13	Rarm, hydraulic log loading	089657-1	1	
14	Fitting, 3/16" Straight Grease	P04107	1	
15	CHAIN, SINGLE LOG LOADER ARM, 9,5M FRAMES	090090-1	1	

9.6 Hydraulic Log Turner

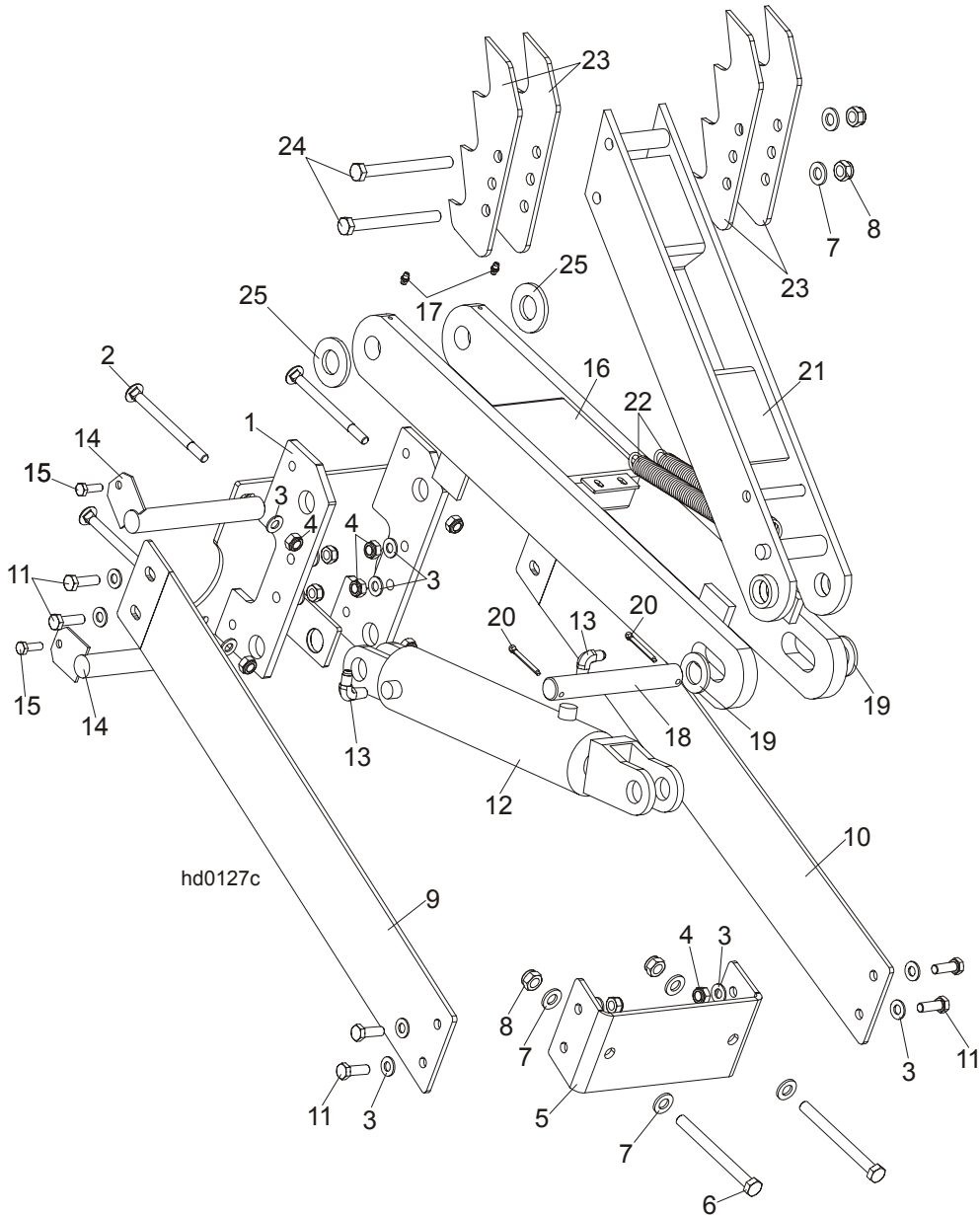

REF	DESCRIPTION (◆ Indicates Parts Available In Assemblies Only)	PART #	QTY.	
	HYDRAULIC LOG TURNER, 9.5 M, COMPLETE	088073	1	
1	Bracket, Hydraulic Log Turner Mount	088710-1	1	
2	Bolt, M10x120 8.8 Mushroom Head Square Neck Zinc	F81003-33	4	
3	Washer, M10 Flat Zinc	F81055-1	20	
4	Nut, M10 Nylon Hex Zinc Lock	F81033-1	12	

5	Bracket, Log Turner Front Mount	094363-1	1	
6	Bolt, M12x130-8.8 Hex Head Zinc	F81004-36	2	
7	Washer, M12 Flat Zinc	F81056-1	6	
8	Nut, M12 Hex Nylon Zinc Lock	F81034-2	4	
9	Plate, Short Log Turner Left Brace	094364-1	1	
10	Plate, Short Log Turner Right Brace	094365-1	1	
11	Bolt, M10x30mm Hex Head Grade 5.8 Zinc	F81003-2	8	
	Cylinder Assy, Log Turner Super	015563	1	
12	Cylinder, CJ-S305-16-63/28/203 Hydraulic	088679	1	
13	Fitting, 1/4NPTx1/4JIC Male Elbow	P09142	2	
14	Pin, Log Turner Mount	088667-1	2	
15	Bolt, M8 x 25mm Hex Head Grade 5.8 Zinc	F81002-5	2	
16	Arm, Hydraulic Log Turner Link	088060-1	1	
17	Fitting, M6 Straight Grease	086280	2	
18	Pin, 25 x 180	088664	1	
19	Washer, 25 Flat Zinc	F81061-3	2	
20	Pin, 5x40 Cotter Zinc	F81043-31	2	
21	Arm, Hydraulic Log Turner Painted	088067-1	1	
22	Spring, 7/8x81/2x1/8 Extension	P09136	2	
23	Claw, Hydraulic Log Turner	088082-1	4	
24	Bolt, M12x130-8.8 Hex Head Zinc	F81004-36	2	
25	Washer, GTM-2644-015	093359	2	



HYDRAULIC SYSTEM

Hydraulic Log Clamp, Front and Rear

9.7 Hydraulic Log Clamp, Front and Rear

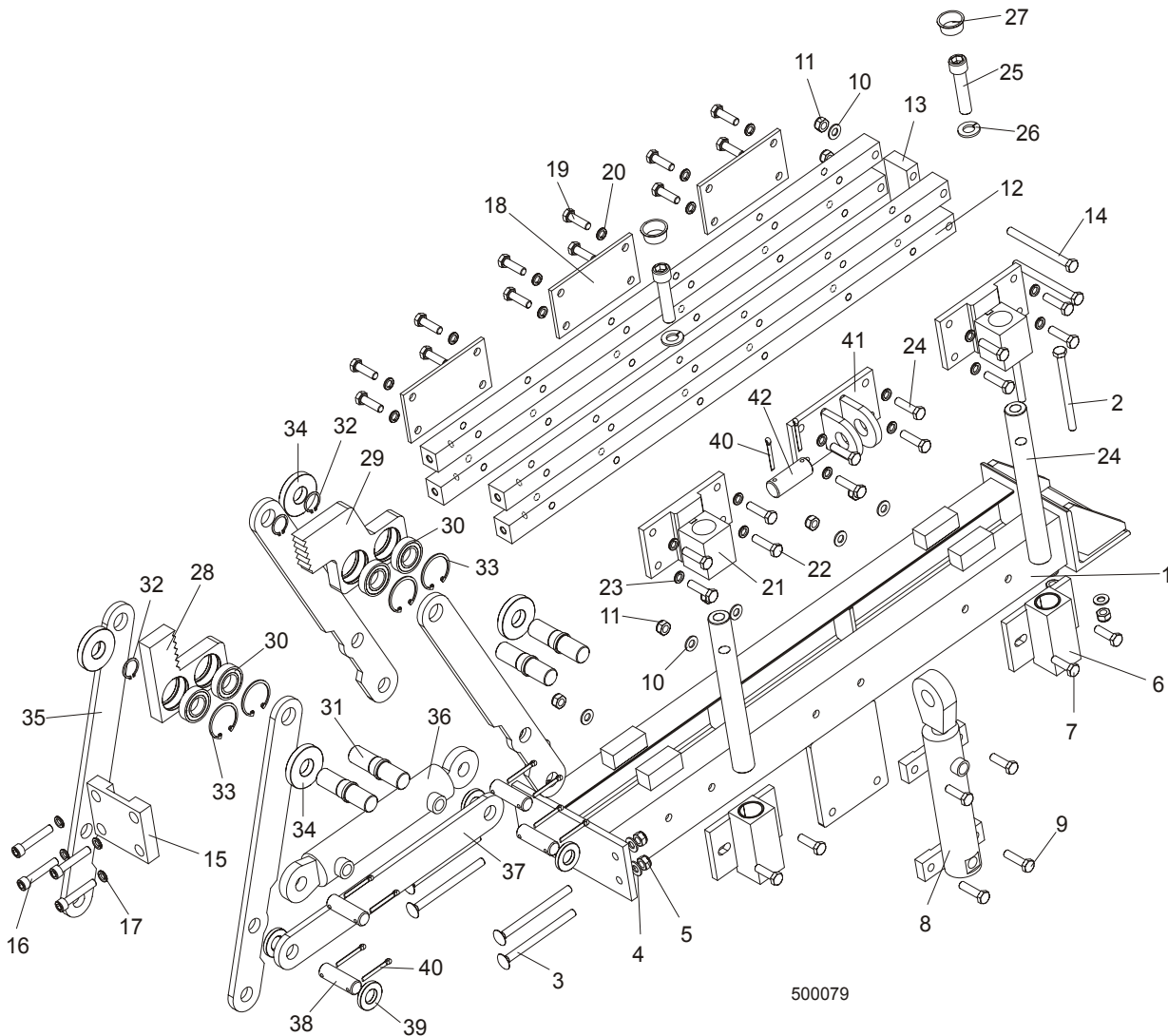

REF	DESCRIPTION (◆ Indicates Parts Available In Assemblies Only)	PART #	QTY.
	CLAMP ASSEMBLY, HYDRAULIC	089545	2
1	Mount Weldment, Hydraulic Log Clamp	088654-1	1
2	Bolt, M10x125-8.8 Zinc Hex Head	F81003-18	2
3	Bolt, M10x130-8.8 Zinc Mushroom Head Square Neck	F81003-36	4
4	Washer, 10.5 Flat Zinc	F81055-1	6
5	Nut, M10-8-B Hex Nylon Zinc Lock	F81033-1	6
6	Block, Guide Pin	089835-1	2
7	Bolt, M10x35-8.8 Zinc Hex Head Full Thread	F81003-17	4
8	Cylinder, CJ7F-16-40/22 + UE2-40W Hydraulic	088662	1
9	Bolt, M10x40-8.8 Zinc Hex Head	F81003-16	4
10	Washer, M10 Flat Zinc	F81055-1	6
11	Nut, M10-8-b Hex Nylon Zinc Lock	F81033-1	10
12	Bar, Clamp Up/Down	089537-1	4
13	Plate, Connecting	088645-1	1
14	Bolt, M10x140-8.8 Zinc Hex Head	F81003-5	2
15	Plate, Connecting	089533-1	1
16	Bolt, M10x55-8.8 Zinc Hex Socket Head Cap	F81003-55	4

17	Washer, 10.2 Split Lock Zinc	F81055-2	4	
18	Plate, Log Clamp Rear	089538-1	3	
19	Bolt, M10x35-8.8 Zinc Hex Head Full Thread	F81003-17	12	
20	Washer, 10.2 Split Lock Zinc	F81055-2	12	
21	Bracket, Guide Pin Mount	089536-1	2	
22	Bolt, M10x40-8.8 Zinc Hex Head Full Thread	F81003-16	8	
23	Washer, 10.2 Split Lock Zinc	F81055-2	8	
24	Pin, Clamp Up/Down Guide	088631	2	
25	Screw, M16x55-8.8 Zinc Hex Socket Head Cap	F81006-18	2	
26	Washer, 16.3 Split Lock Zinc	F81058-2	2	
27	Plug, M33 Thread	089839	2	
	Jaw, Log Clamp Left - Complete	094700	1	
28	Jaw, Log Clamp Left	093464-1	1	
30	Bearing, 6005 2RS CX	089652	4	
31	Shaft, Clamp Jaw Guide	088620-1	4	
32	Ring, Z24 Spring Retaining	089654	4	
33	Ring, W47 Spring Retaining	089653	4	
	Jaw, Log Clamp Right - Complete	094701	1	
29	Jaw, Log Clamp Right	093465-1	1	
30	Bearing, 6005 2RS CX	089652	4	
31	Shaft, Clamp Jaw Guide	088620-1	4	
32	Ring, Z24 Spring Retaining	089654	4	
33	Ring, W47 Spring Retaining	089653	4	
34	Washer, Clamp Jaw Spacer	089542	4	
35	Bar, Clamp In/Out Side	088622-1	4	
36	Cylinder, SJ2F-40/22/145 Hydraulic	088661	1	
37	Bar, Clamp In/Out Lower	088623-1	1	
38	Pin, 20X75	088657-1	4	
39	Spacer, Lower	089541	4	
40	Pin, S-Zn 5x40 Cotter	F81043-31	10	
41	Bracket, Vertical Cylinder Mount Upper	089540-1	1	
42	Pin, 25X75	088659-1	1	

9.8 Hydraulic Log Clamp

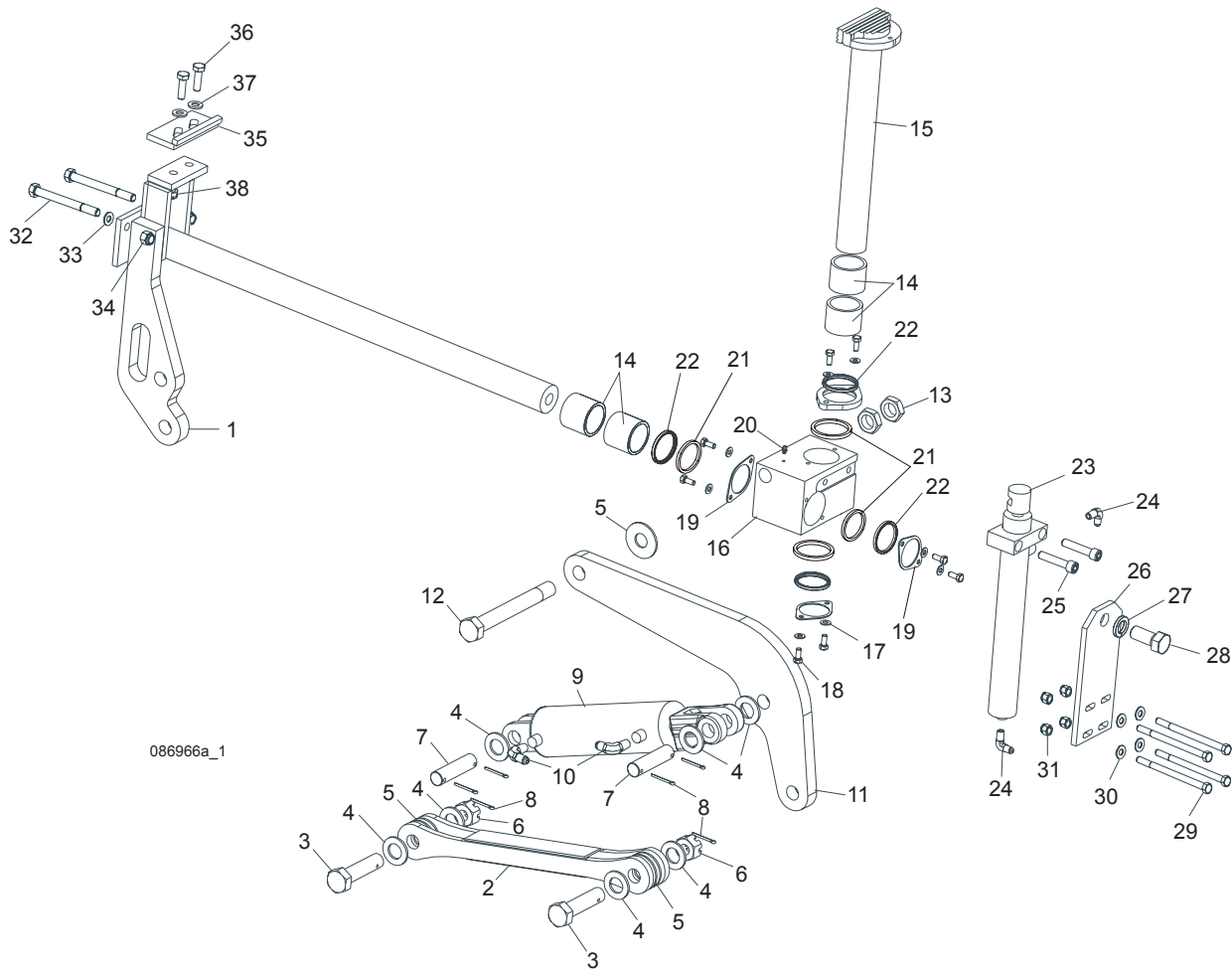

REF	DESCRIPTION (◆ Indicates Parts Available In Assemblies Only)	PART #	QTY.
	CLAMP ASSEMBLY, SUPER HYDRAULIC	088658	1
1	Mount Weldment, Super Clamp Tube	086967-1	1
2	Arm, Clamp Link	086963-1	1
3	Bolt, B 24x95/85 Hex Head Grade 8	F81049-2	1
4	Washer, 25 Flat	F81061-3	8
5	Washer, 25X63 Hardened	088585-1	5
6	Nut, M20-8-B Slotted Hex	F81037-3	2
7	Pin, Cylinder Mount	086979-1	2
8	Pin, 6,3x45 Cotter	F81045-2	6
9	Cylinder, CJ-S96-16-70/32/178 Hydraulic	088589	1
10	Fitting, 1/4" NPT - 3/8" JIC Elbow	P09142	2
11	Link Weldment, Super '99 Clamp	086974-1	1
12	Bolt, M24x217/39 -8.8-B Hex Head Grade 8	088586-1	1
13	Nut, M24 -04-B Hex Jam	F81039-3	2
14	Bushing, Clamp Slide 5040BS	088660	2
15	Clamp Weldment, Vertical Super	088582-1	1
16	Block, Vertical Clamp Mount	088591-1	1
17	Washer, 8.4 Flat	F81054-1	8
18	Bolt, M8x20-8.8-B Hex Head	F81002-4	8
19	Spacer, Log Clamp	088887-1	3

20	Fitting, 3/16" Grease	P04107	1	
21	Spacer, Log Clamp	089324	1	
22	Wiper, Up/Down Rod ZZ 50x60x7	088587	1	
23	Cylinder, CJ-S169-16-40/22/254 Hydraulic	088590	1	
24	Fitting, 1/4" NPT - 1/4" JIC Elbow	P09142	2	
25	Screw, M12x55 -8.8-B Socket Head	F81004-23	2	
26	Plate, Super Log Clamp Mount	086975-1	1	
27	Washer, Z 22,5 Split Lock	F81059-4	1	
28	Bolt, M22x1,5x40 -8.8-B Hex Head Grade 5	F81009-1	1	
29	Bolt, M10 x 125-8.8 Hex Head	F81003-18	4	
30	Washer, 10.5 Flat	F81055-1	4	
31	Nut, M10-8-B Hex Nylon Lock	F81033-1	4	
32	Bolt, M10 x 140-8.8 Hex Head	F81004-37	2	
33	Washer, 13 Flat	F81056-1	2	
34	Nut, M12-8 Hex Nylon Lock	F81034-1	2	
	CLAMP STOP KIT, HYDRAULIC LOG	K09485	1	
35	Plate, Clamp Stop	086980-1	1	
36	Bolt, M12 x 40-8.8 Hex Head	F81004-4	2	
37	Washer, 13 Flat	F81056-1	2	
38	Nut, M12-8 Hex Nylon Lock	F81034-2	2	

9.9 Hydraulic Toe Board, Middle

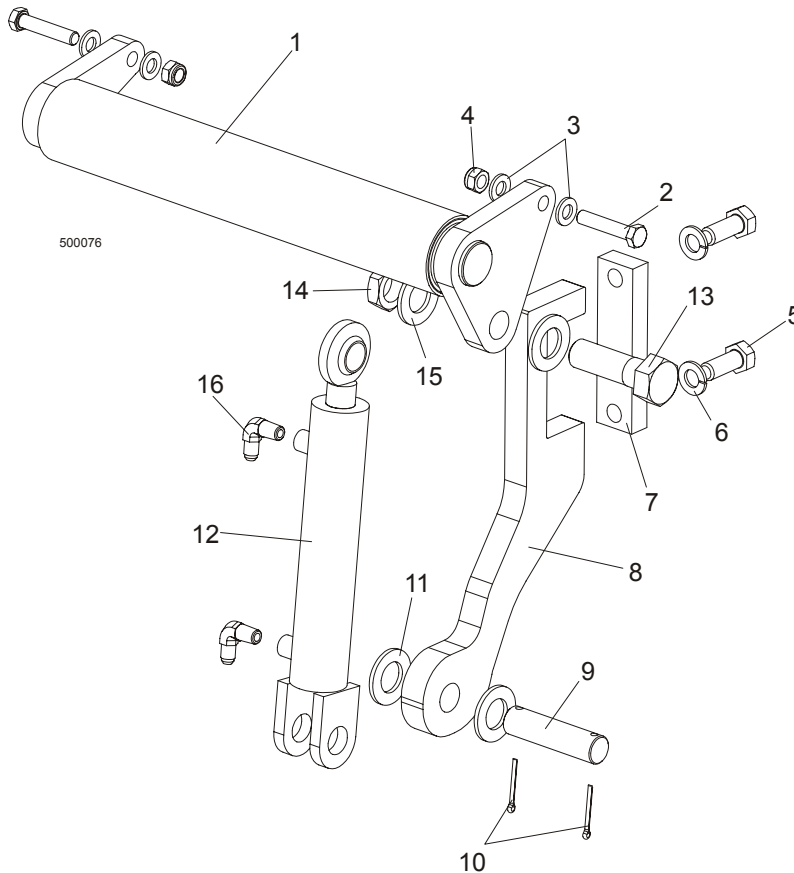

REF	DESCRIPTION (◆ Indicates Parts Available In Assemblies Only)	PART #	QTY.	
	HYDRAULIC TOE BOARD ASSEMBLY, MIDDLE	090055		
1	Toe Board Weldment, Hydraulic	086253-1	1	

9

HYDRAULIC SYSTEM

2	Bolt, M12x60-8.8 Zinc Hex Head	F81004-5	1	
3	Washer, 13 Zinc Flat	F81056-1	4	
4	Pin, S-Zn 2.5x20 Cotter	F81043-1	2	
5	Bolt, M16X40-8.8 Zinc Hex Head Full Thread	F81006-13	2	
6	Washer, 16.3 Zinc Split Lock	F81058-2	2	
7	Plate, Hydraulic Toe Board Mount	090086-1	1	
8	Bracket, Hydraulic Toe Board Mount	089990-1	1	
9	Pin, Hydraulic Cylinder Mount Zinc	086979-1	1	
10	Pin, S-Zn 3/16 X 1 1/2" Cotter	F05012-23	2	
11	Washer, 28 Zinc Flat	F81061-1	2	
12	Cylinder, CJ-S170-16-40/25/152 Hydraulic	088681	1	
	Seal Kit, 1 1/2" x 6" Hydraulic Cylinder	014547	1	
13	Bolt, 1-8 X 3 1/4 HH Hex Head Grade 5	F05009-51	1	
14	Nut, 1"-14	F05010-117	1	
15	Washer, 28 Zinc Flat	F81061-1	1	
16	Fitting, C5205x4x4 Male	P09143	2	

9.10

9.11 Hydraulic Log Side Supports (L Type Frame)

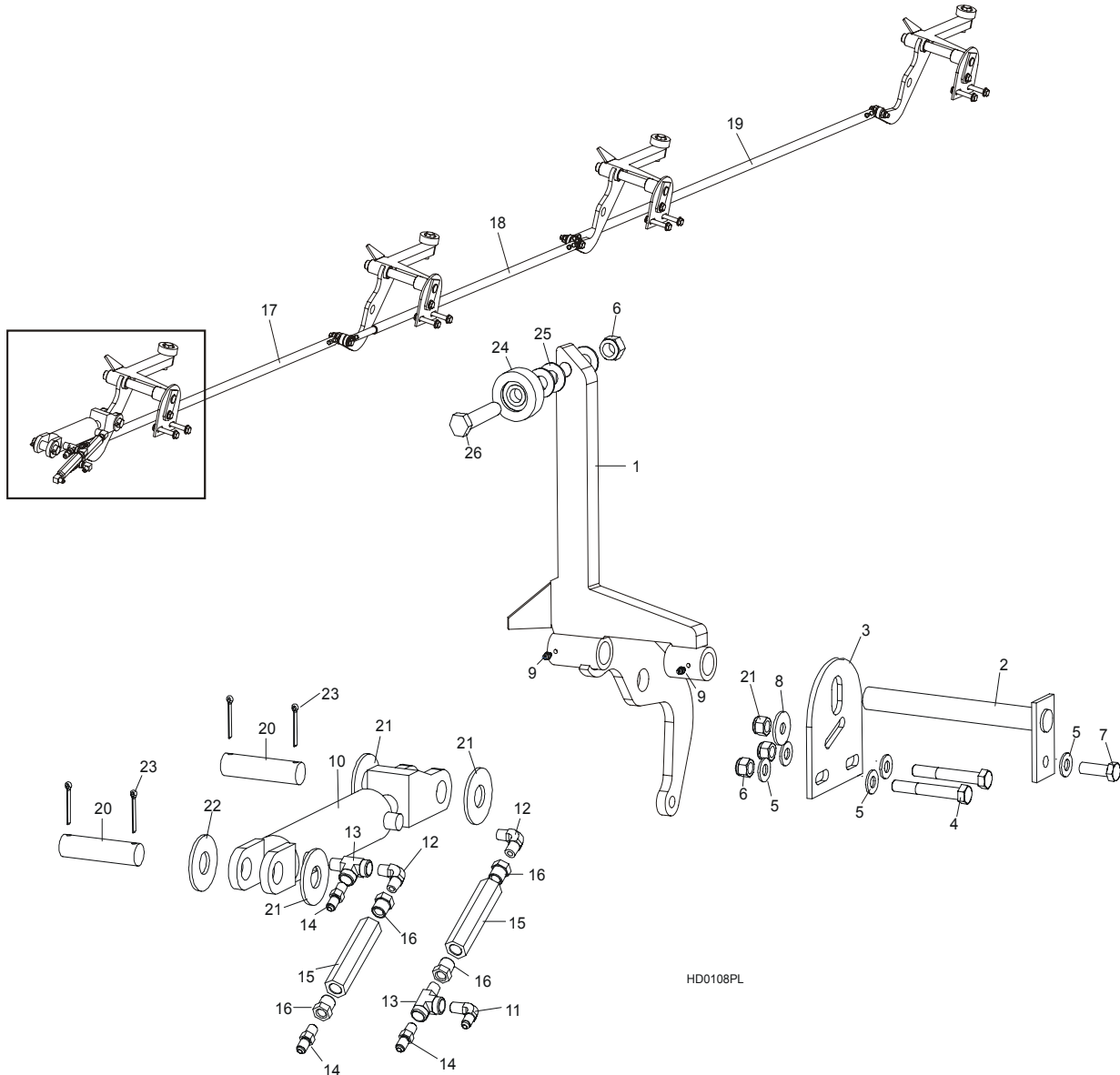

REF	DESCRIPTION (◆ Indicates Parts Available In Assemblies Only)	PART #	QTY.
	HYDRAULIC LOG SIDE SUPPORTS (L TYPE FRAME)	093746	1
1	SUPPORT, HYDRAULIC LOG SIDE	091653-1	4
2	PIN, LOG SIDE SUPPORT PIVOT	091549-1	4
3	PLATE, LOG SIDE SUPPORT END	091591-1	4
4	BOLT, M12X75-8.8 HEX HEAD ZINC	F81004-21	8
5	WASHER, 13 FLAT ZINC	F81056-1	20
6	NUT, M12-8 HEX NYLON ZINC LOCK	F81034-2	12
7	BOLT, M12 X 35-8.8 HEX HEAD FULL THREAD ZINC	F81004-24	4
8	WASHER, 15 SPECIAL FLAT ZINC	F81057-3	4
9	FITTING, 3/16" GREASE	P04107	8
	CYLINDER ASSY, 2x6 SIDE SUPPORT SUPER	015561	1
10	Cylinder, CJ-S270-16-50/28/152 Hydraulic	088678	1
	Seal Kit, 6" x 2" Hydraulic Cylinder	P12954	1

HYDRAULIC SYSTEM*Hydraulic Log Side Supports (L Type Frame)*

11	Fitting, 3/8JIC-1/4NPT 90L	015491	2	
12	Fitting, C3529x4 90° Pipe	P09140	4	
13	Fitting, C3759x4 Male 'T'	P09141	2	
14	Fitting, 3/8JIC-1/4NPT Str	015560	2	
15	Valve, Hydraulic Sequence	015484	2	
16	Fitting, 3/8" NPT - 1/4" NPT Reducer	015490	4	
17	ROD, HYDRAULIC SIDE SUPPORT LINK L-1675 COMPLETE	089842	1	
18	ROD, HYDRAULIC SIDE SUPPORT LINK L-1480 COMPLETE	089376	1	
19	ROD, HYDRAULIC SIDE SUPPORT LINK L-1960 COMPLETE	089377	1	
20	PIN, CYLINDER MOUNT	086979-1	2	
21	WASHER, 28 FLAT ZINC	F81061-1	3	
22	WASHER, 26 FLAT ZINC DIN 1440	F81054-8	1	
23	PIN, 5 X 40 COTTER	F81043-31	4	
	ROLLER KIT, SIDE SUPPORT	015109	4	
24	ROLLER ASSEMBLY, SIDE SUPPORT	015014-1	4	
25	WASHER, 17 FLAT ZINC	F81058-1	12	
26	BOLT, M16x65MM, HH F/THRD, GRADE 5.8, ZINC	F81006-1	4	
	Instruction Sheet, Side Support Roller	015109-526	1	

9.12 Hydraulic Log Clamp - main

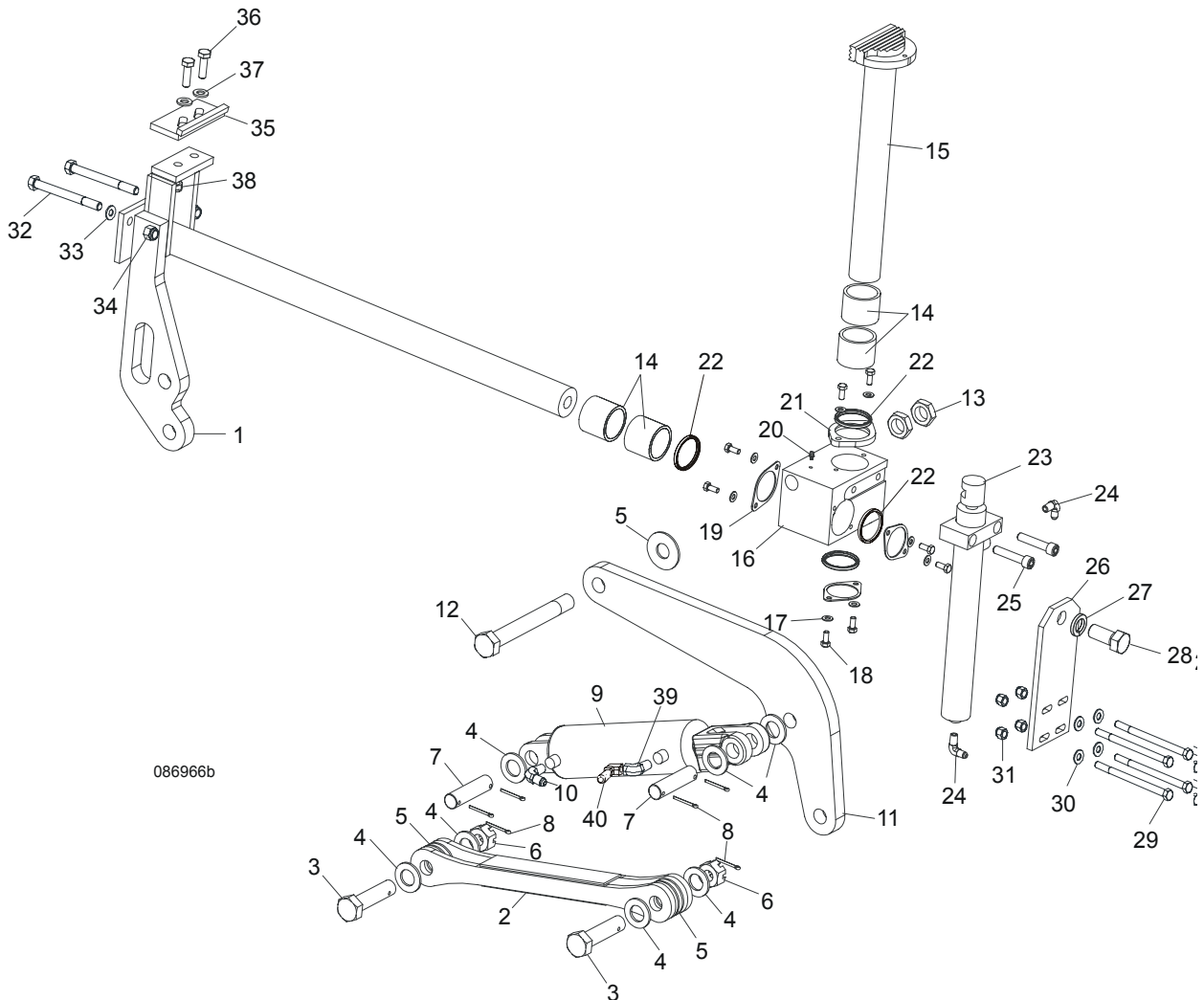

L.P.	OPIS (◆ wskazuje części dostępne jedynie w zespołach)	NUMER KAT.	SZT.
	HYDRAULIC LOG CLAMP ASSEMBLY	088658	1
1	Rod Weldment, Log Clamp Slide Ptd	086967-1	1
2	Arm Weldment, Hydraulic Clamp Link Ptd	086963-1	1
3	Pin, B 24x95/85-Clevis Zinc	F81049-2	1
4	Washer, 25 Flat Zinc	F81061-3	8
5	Washer, 25X63 Zinc-Plated	088585-1	5
6	Nut, Z M20-8-B-Slotted Castle Zinc	F81037-3	2
7	Pin, Hydraulic Cylinder Zinc-Plated	086979-1	2
8	Pin, S-Zn 6,3x45 Cotter	F81045-2	6
9	Cylinder, CJ-S96-16-70/32/178 Hydraulic	088589	1
10	FITTING, 3/8JIC-1/4 NPT STR	015560	1
11	Arm, Hydraulic Log Clamp Link Ptd	086974-1	1
12	Bolt, M24x217/39 -8.8-B- Hex Head Zinc	088586-1	1
13	Nut, M24 -04-B- Hex Thin Zinc	F81039-3	2

14	Bushing, 5040BS Self-Lubricating	088660	2	
15	Rod Weldment, Log Clamp Vertical Painted	088582-1	1	
16	Block, Log Clamp Steel Ptd	088591-1	1	
17	Washer, 8.4 Flat Zinc	F81054-1	8	
18	Bolt, M8x20-8.8-B-Hex Head Full Thread Zinc	F81002-4	8	
19	Flange, Clamp Rod Wiper Ptd	088887-1	3	
20	Fitting, 3/16" Straight Grease	P04107	1	
21	Flange, Clamp Rod Wiper Ptd	088887-1	1	
22	Wiper, ZZ 50x60x7 Log Clamp Rod	088587	1	
23	Cylinder, CJ-S169-16-40/22/254 Hydraulic	088590	1	
24	Fitting, 1/4" NPT - 1/4" JIC Male Elbow	P09142	2	
25	Screw, M12x55 -8.8-B-Hex Socked Head Cap Zinc	F81004-23	2	
26	Plate, Log Clamp Mount Ptd	086975-1	1	
27	Washer, Z 22,5 Split Lock	F81059-4	1	
28	Bolt, M22x1,5x40 -8.8-B-Hex Head Full Thread Zinc	F81009-1	1	
29	Bolt, M10 x 125-8.8 Hex Head Zinc	F81003-18	4	
30	Washer, 10.5 Flat Zinc	F81055-1	8	
31	Nut, M10-8-B Hex Nylon Zinc Lock	F81033-1	4	
32	Bolt, M12x130-8.8-Hex Head Zinc	F81004-36	2	
33	Washer, 13 Flat Zinc	F81056-1	2	
34	Nut, M12-8 Hex Zinc	F81034-1	2	
	STOP KIT, CLAMP	K09485	1	
35	Stop Wldmt, Hydraulic Log Clamp Ptd	086980-1	1	
36	Bolt, M12 x 40 8.8 Hex Head Full Thread Zinc	F81004-4	2	
37	Washer, 13 Flat Zinc	F81056-1	2	
38	NUT, M12-8 HEX NYLON ZINC LOCK	F81034-2	4	
39	FITTING, M/F-90-9/16 JIC ELBOW	500597	1	
40	FITTING, 3/8JIC-1/4NPT 90L	015491	1	

9.13 Hydraulic Toe Board

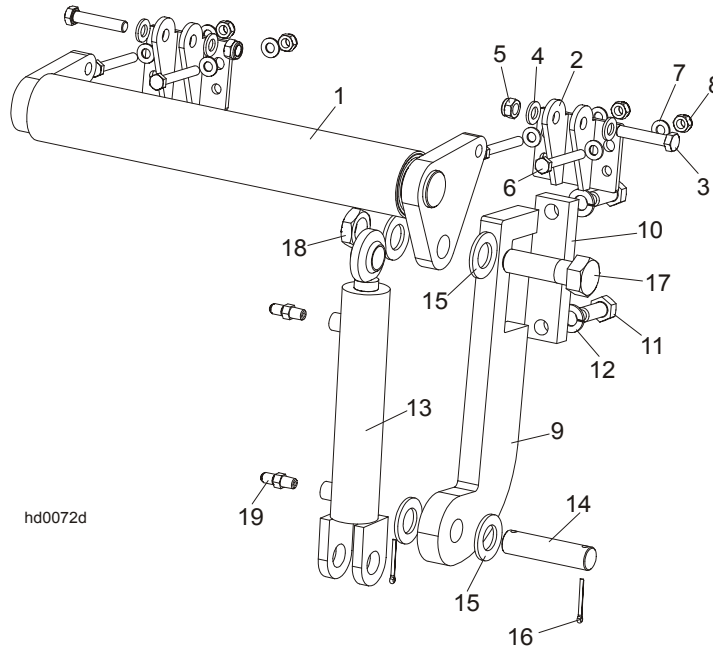

REF	DESCRIPTION (◆ Indicates Parts Available In Assemblies Only)	PART #	QTY.
	HYDRAULIC TOE BOARD - REAR	092634	1
1	Toe Board Weldment, Hydraulic - Rear	086253-1	1
2	Bracket, Hydraulic Toe Board	087903-1	2
3	Bolt, M12x60mm Hex Head Zinc Grade 8.8	F81004-5	4
4	Washer, M12 Flat Zinc	F81056-1	8
5	Nut, M12 Hex Nylon Zinc Lock	F81034-2	4
6	Bolt, M10x75-8.8 Hex Head Zinc	F81003-15	8
7	Washer, M10 Flat Zinc	F81055-1	16
8	Nut, M10 Hex Nylon Zinc Lock	F81033-1	8
9	Bracket, Hydraulic Toeboard Mount	087729-1	2
10	Plate, Hydraulic Toeboard Mount	090086-1	2
11	Bolt, M16x40mm Hex Head Full Thread Zinc Grade 5.8	F81006-13	4
12	Washer, 16.3 Split Lock Zinc	F81058-2	4
13	Cylinder, CJ-S170-16-40/25/152 Hydraulic	088681	2
14	Pin, Cylinder Mount	086979-1	2
15	Washer, 28 Flat Zinc	F81061-1	8
16	Pin, 3/16x1.5 Cotter Zinc	F05012-23	4
17	Bolt, 1-8x3 1/4 Hex Head Grade 5	F05009-51	2
18	Nut, 1-14 Hex Jam Unplated	F05010-117	2
19	Fitting, 1/4NPTx1/4JIC Male	P09143	4