



## user manual

Instrukcja obsługi | Руководство пользователя  
Manuel de l'Utilisateur | Betriebsanweisung  
Bruksanvisning | Manual del Usuario  
Betjeningsvejledning | Gebruikershandleiding  
Käyttöohjeet | Manual de utilizare | Bruksanvisning  
Manuale d'uso | Příručka uživatele | Navodila  
za uporabo

Retain for future use  
Zachować do przyszłego użytku  
Сохраните для последующего  
использования  
A conserver pour une utilisation future  
Für zukünftige Benutzung aufbewahren  
Behold for senere bruk  
Säilytä nämä käyttöohjeet tulevaa tarvetta marten  
Opbevar manualen til fremtidig brug  
Bewaren voor gebruik in de toekomst  
Conservare il presente manuale a l'uso futuro  
Păstrați acest manual pentru utilizare viitoare  
Conservar para futuras consultas  
Behall för framtida användning  
Uchovejte pro další použití  
Hranite za prihodnje uporabo



# **Wood-Mizer®**

## **Sawmill**

### **Safety, Setup, Operation & Maintenance Manual**

---

**LT20L AH**

**rev. D9.04**

---



**Safety is our #1 concern!** Read and understand all safety information and instructions before operating, setting up or maintaining this machine.

*April 2003*

**This is the original language  
for the manual.**

*General Contact Information  
Branches & Authorized Sales Centers*

<b>SECTION 1</b>	<b>SAFETY &amp; GENERAL INFORMATION</b>	<b>1-1</b>
1.1	Blade Handling.....	1-2
1.2	Sawmill Setup.....	1-3
1.3	Sawmill Operation.....	1-4
1.4	Sawmill Maintenance .....	1-6
1.5	Belt Sizes .....	1-7
1.6	Blade Sizes .....	1-7
1.7	Cutting Capacity .....	1-8
1.8	Engine/Motor Specifications .....	1-9
1.9	Overall Dimensions .....	1-10
1.10	Chains .....	1-10
1.11	Hydraulic System .....	1-10
1.12	Sawdust Extractor Specifications .....	1-11
1.13	Components .....	1-12
1.14	Electrical Symbol Diagrams.....	1-13
<b>SECTION 2</b>	<b>SETUP &amp; OPERATION</b>	<b>2-1</b>
2.1	Sawmill Setup.....	2-1
2.2	Stationary Sawmill Setup .....	2-2
2.3	Middle Track Cover .....	2-4
2.4	Replacing The Blade .....	2-5
2.5	Tensioning The Blade.....	2-5
2.6	Tracking The Blade .....	2-7
2.7	Starting The Motor .....	2-9
2.8	Hydraulic Control Operation.....	2-11
2.9	Loading, Turning, And Clamping Logs .....	2-13
2.10	Up/Down Operation .....	2-16
2.11	Blade Guide Arm Operation.....	2-17
2.12	Power Feed Operation .....	2-18
2.13	Cutting The Log .....	2-21
2.14	Edging.....	2-22
2.15	Additional operation for Super sawmills.....	2-23
2.16	Blade Height Scale .....	2-24
2.17	Water Lube Operation .....	2-26
2.18	Preparing The Sawmill For Towing .....	2-28
<b>SECTION 3</b>	<b>MAINTENANCE</b>	<b>3-1</b>
3.1	Wear Life.....	3-1

# Table of Contents

# Section-Page

3.2	Blade Guides .....	3-2
3.3	Sawdust Removal .....	3-2
3.4	Carriage Track, Wiper & Scrapers .....	3-3
3.5	Vertical Mast Rails .....	3-4
3.6	Miscellaneous .....	3-4
3.7	Blade Tensioner .....	3-5
3.8	Blade Wheel Belts .....	3-5
3.9	Drive Belt Adjustment.....	3-6
3.10	Hydraulic System .....	3-8
3.11	Up/Down System.....	3-9
3.12	Power Feed System .....	3-12

## **SECTION 4 TROUBLESHOOTING GUIDE**

**4-1**

4.1	Sawing Problems .....	4-1
4.2	Electrical Problems.....	4-3
4.3	Power Feed Problems .....	4-4
4.4	Hydraulic Problems .....	4-6
4.5	Engine/Motor and Drive Pulleys Alignment.....	4-9
4.6	Hydraulic Pressure Test.....	4-10

## **SECTION 5 SAWMILL ALIGNMENT**

**5-1**

5.1	Pre-Alignment Procedures.....	5-1
5.2	Frame Setup.....	5-2
5.3	Blade Installation And Alignment.....	5-2
5.4	Blade Wheel Alignment .....	5-6
5.5	Adjusting The Lower Track Rollers.....	5-11
5.6	Adjusting Bed Rails To The Blade.....	5-13
5.7	Blade Guide Arm Vertical Adjustment .....	5-15
5.8	Carriage Backlash Removal .....	5-17
5.9	Blade Guide Rope Adjustment.....	5-19
5.10	Blade Guide Arm Horizontal Adjustment.....	5-20
5.11	Aligning the Blade Guides .....	5-22
5.12	Blade Deflection.....	5-23
5.13	Blade Guide Vertical Tilt Adjustment.....	5-24
5.14	Blade Guide Spacing .....	5-26
5.15	Horizontal Tilt Adjustment.....	5-27
5.16	<b>Horizontal Adjustment of Side Supports .....</b>	<b>5-28</b>
5.17	<b>Vertical Adjustment of Side Supports.....</b>	<b>5-29</b>
5.18	Saw Head Tilt.....	5-30
5.19	Blade Height Scale Adjustment.....	5-32

This manual is to replace or to be used with all previous information received on the Wood-Mizer® sawmill. All future mailings will be an addition to or a revision of individual sections of this manual as we obtain new information.

The information and instructions given in this manual do not amend or extend the limited warranties for the equipment given at the time of purchase.

### ***If You Need To Order Parts...***

From Europe call our European Headquarters and Manufacturing Facility in Kolo, Poland at **+48-63-2626000**. Please have the vehicle identification number and your customer number ready when you call. Wood-Mizer will accept these methods of payment:

- Visa, Mastercard, or Select Purchase
- COD
- Prepayment
- Net 15 (with approved credit)

Be aware that shipping and handling charges may apply. Handling charges are based on size and quantity of order. In most cases, items will ship on the day they are ordered. Second Day and Next Day shipping are available at additional cost.

### ***If You Need Service...***

From Europe call our European Headquarters and Manufacturing Facility in Kolo, Poland at **+48-63-2626000**. Ask to speak with a Customer Service Representative. Please have your vehicle identification number and your customer number ready when you call. The Service Representative can help you with questions about alignment of your mill, blade sharpening, or cutting a particular species of wood. He also can schedule you for a service call.

**Office Hours:** All times are Eastern Standard Time. Please remember that Indiana does not go on Daylight Savings Time in the summer.

Country	Monday - Friday	Saturday	Sunday
U.S., Indiana	8 a.m. to 5 p.m.	8 a.m. to 4 p.m.	Closed
Poland	7 a.m. to 3:00 p.m.	Closed	Closed



**IMPORTANT!** Read the entire Operator's Manual before operating the sawmill. Take notice of all safety warnings throughout this manual and those posted on the machine. Keep this manual with this machine at all times, regardless of ownership.

\*Wood-Mizer® is a registered trademark of Wood-Mizer Products, Inc.

## Sawmill and Customer Identification

Each Wood-Mizer sawmill has a 17-digit Vehicle Identification Number (VIN). See the figure below for VIN locations. See the chart for VIN description.

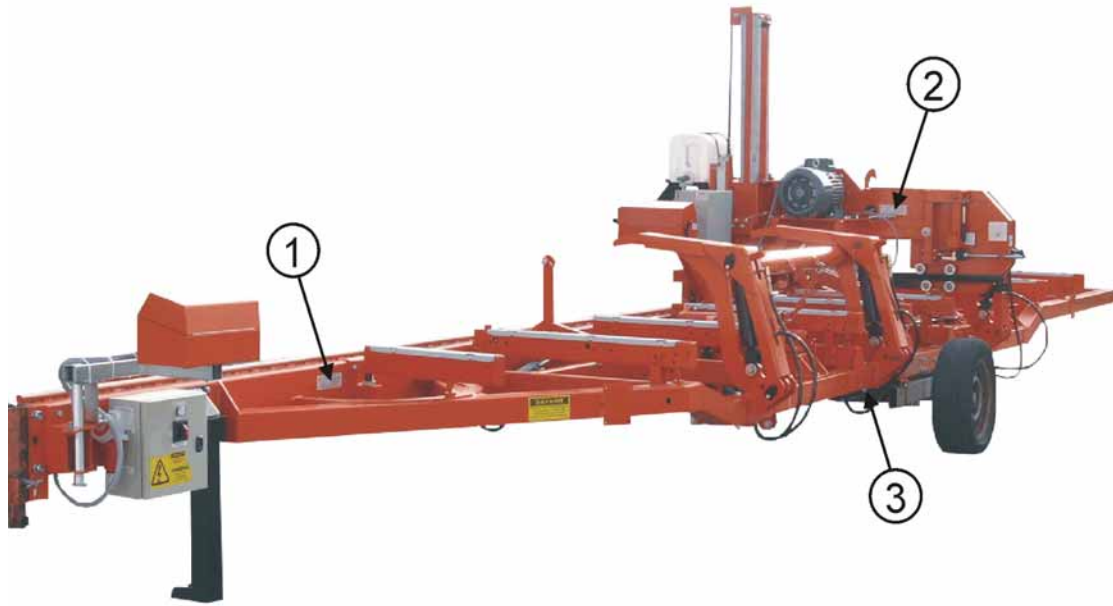

**V.I.N. LOCATIONS.**

<b>456</b>	Company Identification Number 456=Wood-Mizer Indiana		Weight Class; A=Under 1361 kg, B=1361-1814 kg, C=1814-2268 kg, D=2269-3000kg	Product No.; 1=LT10/15, 2=LT20 Series, 4=LT40 Series, 7=LT70 Series	Length of the Trailer; 20= 20' (6 m), 24=24' (7 m), 35=35' (11 m)	Number of axles on the trailer	Check Digit Add all the number and divide by 11	Year of Manufacture; G=2009, H=2010, J=2011, K=2012, L=2013, M=2014	State of Manufacture N=Indiana, P=Poland	Month of Manufacture A=January, B=February, C=March, etc...	Revision Level	Sequence Number Ranging from 000-999	End of 17-Digit VIN	Revision Level (Repeated)	Two-Digit Minor Revision Level
<b>A</b>	<b>4</b>	<b>24</b>	<b>1</b>	<b>X</b>	<b>H</b>	<b>P</b>	<b>A</b>	<b>F9</b>	<b>017</b>	<b>F9</b>	<b>.01</b>				

**V.I.N. DESCRIPTION**

Each sawmill is also identified with a model number which includes the base model and the engine/motor configuration. See the figure for a description of the model number.

**LT20**  
Basic Sawmill I.D.

**E15**  
Engine/Motor  
Configuration

***MODEL NUMBER DESCRIPTION.***

When you pick up your mill, you will receive a customer number. Both the VIN and your customer number expedite our service to you. Please write these numbers below so you have quick, easy access to them.

Customer No.	Model No.	V.I.N.	Revision



# Table of Contents

# Section-Page

<b>SECTION 1</b>	<b>SAFETY &amp; GENERAL INFORMATION</b>	<b>1-1</b>
1.1	Blade Handling.....	1-2
1.2	Sawmill Setup.....	1-3
1.3	Sawmill Operation.....	1-4
1.4	Sawmill Maintenance .....	1-6
1.5	Belt Sizes .....	1-7
1.6	Blade Sizes .....	1-7
1.7	Cutting Capacity .....	1-8
1.8	Engine/Motor Specifications .....	1-9
1.9	Overall Dimensions .....	1-10
1.10	Chains .....	1-10
1.11	Hydraulic System .....	1-10
1.12	Sawdust Extractor Specifications .....	1-11
1.13	Components .....	1-12
1.14	Electrical Symbol Diagrams.....	1-13
<b>SECTION 2</b>	<b>SETUP &amp; OPERATION</b>	<b>2-1</b>
2.1	Sawmill Setup.....	2-1
2.2	Stationary Sawmill Setup .....	2-2
2.3	Middle Track Cover .....	2-4
2.4	Replacing The Blade .....	2-5
2.5	Tensioning The Blade.....	2-6
2.6	Tracking The Blade .....	2-7
2.7	Starting The Motor .....	2-9
2.8	Hydraulic Control Operation .....	2-11
2.9	Loading, Turning, And Clamping Logs .....	2-13
2.10	Up/Down Operation .....	2-16
2.11	Blade Guide Arm Operation.....	2-17
2.12	Power Feed Operation .....	2-18
2.13	Cutting The Log .....	2-21
2.14	Edging.....	2-22
2.15	Additional operation for Super sawmills.....	2-23
2.16	Blade Height Scale .....	2-24
2.17	Water Lube Operation .....	2-26
2.18	Preparing The Sawmill For Towing .....	2-28
<b>SECTION 3</b>	<b>MAINTENANCE</b>	<b>3-1</b>
3.1	Wear Life.....	3-1
3.2	Blade Guides .....	3-2
3.3	Sawdust Removal .....	3-2
3.4	Carriage Track, Wiper & Scrapers .....	3-3
3.5	Vertical Mast Rails .....	3-4
3.6	Miscellaneous .....	3-4

# Table of Contents

# Section-Page

3.7	Blade Tensioner.....	3-5
3.8	Blade Wheel Belts .....	3-5
3.9	Drive Belt Adjustment.....	3-6
3.10	Hydraulic System .....	3-8
3.11	Up/Down System.....	3-9
3.12	Power Feed System .....	3-12
<b>SECTION 4 TROUBLESHOOTING GUIDE</b>		<b>4-1</b>
4.1	Sawing Problems .....	4-1
4.2	Electrical Problems.....	4-3
4.3	Power Feed Problems .....	4-4
4.4	Hydraulic Problems .....	4-6
4.5	Engine/Motor and Drive Pulleys Alignment .....	4-9
4.6	Hydraulic Pressure Test.....	4-10
<b>SECTION 5 SAWMILL ALIGNMENT</b>		<b>5-1</b>
5.1	Pre-Alignment Procedures.....	5-1
5.2	Frame Setup.....	5-2
5.3	Blade Installation And Alignment.....	5-2
5.4	Blade Wheel Alignment .....	5-6
5.5	Adjusting The Lower Track Rollers.....	5-11
5.6	Adjusting Bed Rails To The Blade.....	5-13
5.7	Blade Guide Arm Vertical Adjustment .....	5-15
5.8	Carriage Backlash Removal .....	5-17
5.9	Blade Guide Rope Adjustment.....	5-19
5.10	Blade Guide Arm Horizontal Adjustment.....	5-20
5.11	Aligning the Blade Guides .....	5-22
5.12	Blade Deflection .....	5-23
5.13	Blade Guide Vertical Tilt Adjustment.....	5-24
5.14	Blade Guide Spacing .....	5-26
5.15	Horizontal Tilt Adjustment.....	5-27
5.16	<b>Horizontal Adjustment of Side Supports .....</b>	<b>5-28</b>
5.17	<b>Vertical Adjustment of Side Supports.....</b>	<b>5-29</b>
5.18	Saw Head Tilt.....	5-30
5.19	Blade Height Scale Adjustment.....	5-32



# 1 Introduction

## General Contact Information

---

### Getting Service

Wood-Mizer is committed to providing you with the latest technology, best quality and strongest customer service available on the market today. We continually evaluate our customers' needs to ensure we're meeting current wood-processing demands. Your comments and suggestions are welcome.

### General Contact Information

From Europe call your local distributor or our European Headquarters and Manufacturing Facility in Kolo, Nagórna 114 St, Poland at **+48-63-2626000**. From the continental U.S., call our U.S. Headquarter 8180 West 10th St. Indianapolis, IN 46214, toll-free at **1-800-525-8100**. Ask to speak with a Customer Service Representative. Please have your machine identification number and your customer number ready when you call. The Service Representative can help you with questions about the operation and maintenance of your machine. He also can schedule you for a service call.

### Office Hours:

Country	Monday - Friday	Saturday	Sunday
Poland	7 a.m.- 3 p.m.	Closed	Closed
US	8 a.m.- 5 p.m.	8 a.m.- 12 p.m	Closed

Please have your vehicle identification number and your customer number ready when you call.

Wood-Mizer will accept these methods of payment:

- Visa, Mastercard, or Discover
- COD
- Prepayment
- Net 15 (with approved credit)

Be aware that shipping and handling charges may apply. Handling charges are based on size and quantity of order.

**Branches & Authorized Sales Centers**

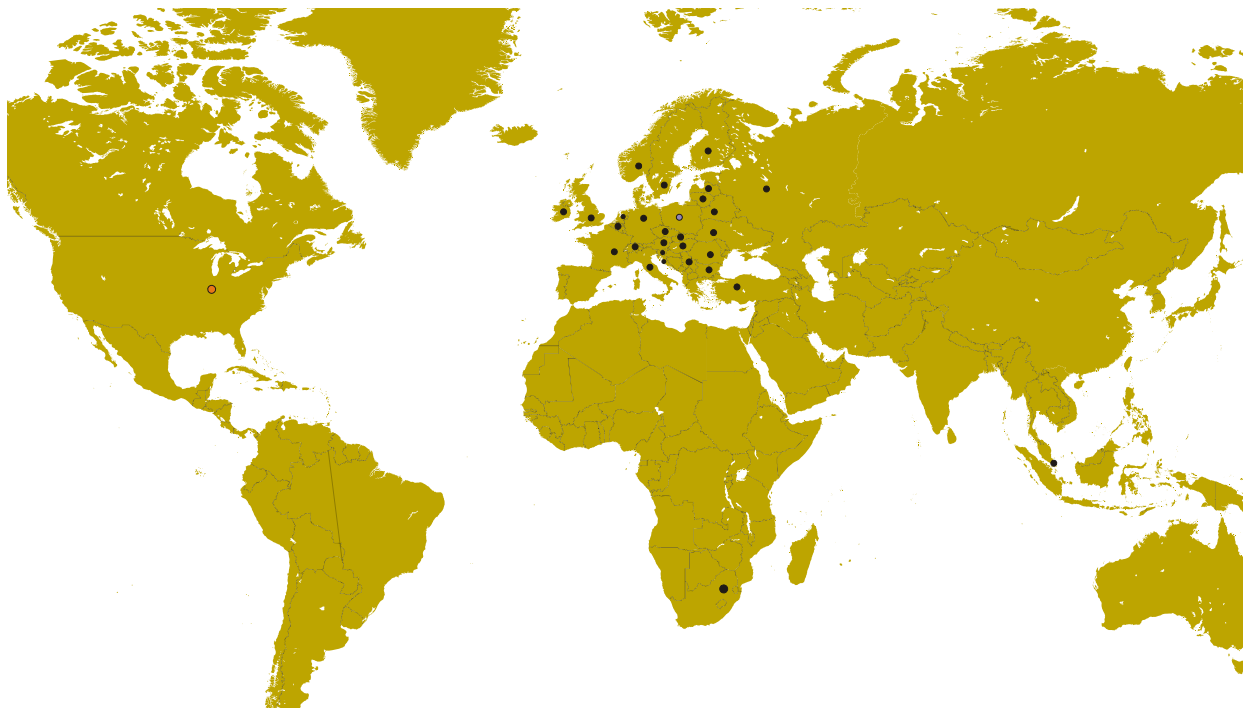

EUROPE		UNITED STATES
<p><b>European Headquarters</b>  <b>Wood-Mizer Industries Sp. z o.o.</b>                      Nagórna 114, 62-600 Koło, Poland                      Tel.: +48-63-26-26-000                      Fax: +48-63-27-22-327  <a href="http://www.woodmizer.eu">www.woodmizer.eu</a></p>		<p><b>World Headquarters</b>  <b>Wood-Mizer LLC</b>                      8180 West 10th Street                      Indianapolis, Indiana 46214-2400,                      USA                      Tel.: +1-317-271-1542                      Fax: +1-317-273-1011  <a href="http://www.woodmizer.com">www.woodmizer.com</a></p>
<p><b>BELARUS</b>  <b>MOST-GRUPP</b>                      Siemashko 15, k.3                      Minsk 2200116                      Tel.: +375-17-270-90-08                      Fax: +375-17-270-90-08                      GSM: +375-29-649-90-80                      e-mail: <a href="mailto:most-by@mail.ru">most-by@mail.ru</a></p>	<p><b>SWITZERLAND Bruno Steiner</b>                      Striegelgasse 2                      CH-6214 Schenkon                      Tel.: +41-41-921-13-01                      Fax: +41-41-922-18-87                      e-mail: <a href="mailto:info@mobilsaegen.ch">info@mobilsaegen.ch</a></p>	<p><b>RUSSIA Dariusz Mikołajewski</b>  <b>OOO WOOD-MIZER INDUSTRIES</b>                      141031, Moscow                      Reg., Mytishenski raj., pos. Veshki,                      Zavodskaja str., 3B                      Tel.Fax: +7(495) 788-72-35                      Tel.Fax: +7(495) 641-51-60                      e-mail: <a href="mailto:dariuszm@woodmizer-moscow.ru">dariuszm@woodmizer-moscow.ru</a></p>



## Introduction

### Branches & Authorized Sales Centers

<p><b>BULGARIA Kalin Simeonov</b> <b>Ecotechproduct</b> 38 Star Lozenski pat str. Sofia 1186 Tel.: +359-2-462-7035 Tel.: +359-2-963-1656 Tel./Fax : +359-2-979-1710 <b>Kalin Simeonov</b> GSM: +3592-963-2559 e-mail: <a href="mailto:office@ecotechproduct.com">office@ecotechproduct.com</a></p>	<p><b>HUNGARY Wiktor Turoczy</b> <b>Wood-Mizer Hungary K.F.T.</b> Szonyi Ut 67., 2921 Komárom Tel./Fax: +36-34-346-255 e-mail: <a href="mailto:woodmizer@woodmizer.hu">woodmizer@woodmizer.hu</a></p>	<p><b>RUSSIA Far East Wladimir Glazaczew</b> <b>"WM Service"</b> Krasnoretchenskaya Str.111 680006 Khabarovsk Tel./Fax: +7-914-541-1183 e-mail: <a href="mailto:wms-khv@mail.ru">wms-khv@mail.ru</a></p>
<p><b>CROATIA Krešimir Pregernik</b> <b>Pregimex d.o.o.</b> S. Batušića 31, 10090 Zagreb Tel./Fax: +3851-38-94-668 <b>Krešimir Pregernik</b> GSM: +3851-98-207-106 e-mail: <a href="mailto:Kresimir.Pregernik@gmail.com">Kresimir.Pregernik@gmail.com</a></p>	<p><b>ITALY Felice Pasquale</b> <b>Wood-Mizer Italia Srl</b> <b>Cda. Capoiaccio SN</b> 86012 Cercemaggiore Campobasso Tel./Fax: +39-0874-798-357 GSM: +39-333-281-03-79 e-mail: <a href="mailto:wmitaliasrl@gmail.com">wmitaliasrl@gmail.com</a></p>	<p><b>SERBIA Dragan Markov</b> <b>Wood-Mizer Balkan d.o.o.</b> Svetosavska GA 3/3; P. Fah 25 23 300 Kikinda Tel./Fax: +381-230-25-754 Tel./Fax: +381-230-23-567 GSM: +381-63-568-658 e-mail: <a href="mailto:office@woodmizer.co.yu">office@woodmizer.co.yu</a></p>
<p><b>CZECH REPUBLIC Miroslaw Greill</b> <b>Wood-Mizer CZ s.r.o.</b> Osvaldova 91 339 01 Klatovy-Luby Tel./Fax: +420-376-312-220 Fax: +420-376-319-011 <b>Miroslaw Greill</b> GSM: +420-723-580-799 e-mail: <a href="mailto:greill@woodmizer.cz">greill@woodmizer.cz</a></p>	<p><b>Subagent:</b> <b>ITALY Franz Josef Reichsigl</b> Muls 21, 39058 Samnthein Tel./Fax: +39-471-627-264 GSM: +39-335-824-88-05</p>	<p><b>SLOVAKIA Wiktor Turoczy</b> <b>Wood-Mizer Danubia s.r.o.</b> Hadovce 5, 94501 Komárno Tel.: +421-35-77-40-316 Fax: +421-35-7740-326 GSM: +421-905-930-972 e-mail: <a href="mailto:woodmizer@woodmizer.sk">woodmizer@woodmizer.sk</a></p>
<p><b>CZECH REPUBLIC Lubomir Kudlik</b> <b>Wood-Mizer Moravia</b> Sovadinova 6 69002 Breclav Tel./Fax: +420-519-322-443 <b>Lubomir Kudlik</b> GSM: +420-602-734-792 e-mail: <a href="mailto:info@wood-mizer.net">info@wood-mizer.net</a></p>	<p><b>LATVIA Vilmars Jansons</b> <b>OBERTS Ltd</b> Gaujas str. 32/2 LV-2167 Marupe, Rigas Raj. Tel.: +371-7-810-666 Fax: +371-7-810-655 <b>Vilmars Jansons</b> GSM: +371-92-06-966 <b>Andris Orols</b> GSM: +371-28-33-07-90 e-mail: <a href="mailto:andris@oberts.lv">andris@oberts.lv</a></p>	<p><b>TURKEY</b> <b>Er-Ka Ahsap Profil Kerestecilik San. ve Tic. Ltd. Sti.</b> Adana Keresteciler Sitesi 191 sk No.41 ADANA Tel.: +90-322-346-15-86 Fax: +90-322-345-17-07 GSM: +90-533-363-18-44 e-mail: <a href="mailto:info@erkaahsap.com.tr">info@erkaahsap.com.tr</a></p>
<p><b>FINLAND Howard Blackbourn</b> <b>Oy Falkberg Jordbruk Ab</b> Falkintie 220 25610 Ylonkyla Tel.: +358-2732-2253 Fax: +358-2732-2263 <b>Howard Blackbourn</b> GSM: +358-440-424-339 e-mail: <a href="mailto:falkberg@woodmizer.fi">falkberg@woodmizer.fi</a></p>	<p><b>LITHUANIA Andrius Zuzevicius</b> <b>UAB Singlis</b> Savanoriu pr. 187, 2053 Vilnius Tel.: +370-5-2-32-22-44 Fax: +370-5-2-64-84-15 GSM: +370-620-28-645 e-mail: <a href="mailto:andrius.z@singlis.lt">andrius.z@singlis.lt</a></p> <p><b>Dmitrij Gaiduk</b> GSM: +370-69-84-51-91 e-mail: <a href="mailto:dmitrijus.g@singlis.lt">dmitrijus.g@singlis.lt</a></p>	<p><b>UKRAINE Ivan Vinnicki</b> <b>MOST UKRAINA</b> bul. Myru 3, Bajkivtsi Ternoplskyj r-j Ternopolska oblast 47711 Ukraine Tel/Fax: +38 (0352) 52 37 74 GSM: +38 (067) 352 54 34 GSM: +38 (067) 674 50 68 E-mail: <a href="mailto:most-ukraine@ukr.net">most-ukraine@ukr.net</a></p>

<p><b>FRANCE Laurence Serrurier</b> Wood-Mizer France Zac du Prè Marechal Route de Fruges 62560 Fauquembergues Tel: +33-321-930-544 Fax: +33-321-930-990 GSM: +33-607-025-282 Mail: <a href="mailto:lserrurier@woodmizer.fr">lserrurier@woodmizer.fr</a></p>	<p><b>NORWAY Odd Edvoll</b> <b>Wood-Mizer Nordic AS</b> Vardelia 17, 2020 Skedsmokorset Tel.: +47-63-87-49-89 Fax: +47-63-87-37-66 GSM: +47-930-42-335 e-mail: <a href="mailto:odd.edvoll@woodmizer.no">odd.edvoll@woodmizer.no</a>  e-mail: <a href="mailto:firmapost@woodmizer.no">firmapost@woodmizer.no</a></p>	<p><b>UNITED KINGDOM &amp; IRELAND</b> <b>Wood-Mizer UK</b> Hopfield Barn Kenward Road, Yalding Kent ME18 6JP, UK Tel.: +44-1622-813-201 Fax: +44-1622-815-534 e-mail: <a href="mailto:info@woodmizer.co.uk">info@woodmizer.co.uk</a></p>
<p><b>SLOVENIA Jan Fale</b> <b>FAMTEH d.o.o.</b> Gacnikova pot 2, 2390 Ravne na Koroskem Tel.: +386-2-62-04-232 Fax: +386-2-62-04-231 <b>Jan Fale</b> GSM: +386-2-62-04-230 e-mail: <a href="mailto:jan.fale@famteh.si">jan.fale@famteh.si</a></p> <p><b>Matjaz Kolar</b> Tel.: +386-2-62-04-232 GSM: +386-31-775-999 e-mail: <a href="mailto:matjaz.kolar@famteh.si">matjaz.kolar@famteh.si</a></p>		<p>David Darnell 10 Tennyson Avenue Southend on Sea Essex, SS2 5HD David Darnell GSM: +44 7799 063 497</p> <p>Stephan Cull Cembrandy Gardens, Manorwen Fishguard, Pembrokeshire SA659PT Tel.: +44-1348-873-179 GSM: +44-7887-544-333</p>
<p><b>GERMANY Klaus Longmuss</b> <b>Wood-Mizer Sägewerke GmbH</b> Dorfstraße 5, 29485 Schletau Tel.: +49-5883-9880-10 Fax: +49-5883-9880-20 e-mail: <a href="mailto:info@woodmizer.de">info@woodmizer.de</a></p> <p><b>Klaus Longmuss</b> Tel.: +49-5883-9880-12 GSM: +49-17-298-55-892 e-mail: <a href="mailto:KLongmuss@woodmizer.de">KLongmuss@woodmizer.de</a></p>	<p><b>Subagent:</b> <b>SWEDEN Kjell Larsson</b> <b>Mekwood AB</b> Slingan 14, 812 41 Gästrike-Hammarby Tel.: +46-290-515-65 <b>Kjell Larsson</b> GSM: +46-706-797-965 e-mail: <a href="mailto:kjell.larsson@mekwood.se">kjell.larsson@mekwood.se</a></p>	<p><b>IRELAND</b> <b>Wood-Mizer Ireland</b> Stephen Brennan Cum Lahardane Ballina County Mayo Tel:+353 96 51345  E-mail: <a href="mailto:brennanmill@ericom.net">brennanmill@ericom.net</a></p>
<p><b>Subagents:</b> <b>DENMARK Brian Jensen</b> Arnborgvej 9, 7330 Brande- Fasterholt Tel.: +45-971-88-265 Fax: +45-971-88-266 <b>Brian Jensen</b> GSM: +45-23-49-5828 e-mail: <a href="mailto:Fasterholt-Savvaerk@Mail.Tele.dk">Fasterholt-Savvaerk@Mail.Tele.dk</a></p>	<p><b>ROMANIA Adrian Echert</b> <b>SC WOOD-MIZER RO SRL</b> TRANSILVANIEI Nr. 5 Sibiu, Cismadie 555300 Tel./Fax: : +40-369-405-433 GSM: +40-745-707-323 e-mail: <a href="mailto:aechert@woodmizer.ro">aechert@woodmizer.ro</a></p>	<p>Regional Manager - Asia Wood-Mizer Asia Pte Ltd. James Wong Tel: +65 81216910 Fax: +65 6283 8636 WWW: <a href="http://www.woodmizerasia.com">www.woodmizerasia.com</a> E-mail: <a href="mailto:jwong@woodmizerasia.com">jwong@woodmizerasia.com</a></p>
<p><b>Netherlands Chris Dragt</b> Lange Brink 77d, 7317 BD Apeldoorn Tel.: +31-55312-1833 Fax: +31-55312-2042 e-mail: <a href="mailto:Info@dragtbosbouw.nl">Info@dragtbosbouw.nl</a></p>	<p><b>Subagent:</b> <b>ROMANIA M. Echert</b> <b>S.C. Echert Comprod s.r.l</b> Str. Schitului Nr. 6, Apt.7 etajul-1 725 70 Vatra Dornei, Romania Tel./Fax: +40-230-374-235 Tel. : +40-740-35-35-74</p>	<p>Regional Manager - Africa Wood-Mizer Africa Jean-Jacques Oelofse UNIT 3, LEADER PARK, NO: 20 CHARIOT ROAD STORMILL, EXT 5, Roodepoort, Johannesburg Tel: +27 011 473 1313 Fax: +27 011 473 2005 Jean-Jacques Oelofse E-mail: <a href="mailto:jjoelofse@woodmizerafrika.com">jjoelofse@woodmizerafrika.com</a> Jean-Jacques Oelofse Skype:jean.jacques.pierre.oelofse</p>

## SECTION 1 SAFETY & GENERAL INFORMATION



This symbol calls your attention to instructions concerning your personal safety. Be sure to observe and follow these instructions. This symbol accompanies a signal word. The word **DANGER** indicates an imminently hazardous situation which, if not avoided, will result in death or serious injury. **WARNING** suggests a potentially hazardous situation which, if not avoided, could result in death or serious injury. **CAUTION** refers to potentially hazardous situations which, if not avoided, may result in minor or moderate injury to persons or equipment. Read all safety instructions before operating this equipment and observe all safety warnings!



Warning stripes are placed on areas where a single decal would be insufficient. To avoid serious injury, keep out of the path of any equipment marked with warning stripes.

Read and observe all safety instructions before operating this equipment! Also read any additional manufacturer's manuals and observe any applicable safety instructions including dangers, warnings, and cautions.

Always be sure that all safety decals are clean and readable. Replace all damaged safety decals to prevent personal injury or damage to the equipment. Contact your local distributor, or call your Customer Service Representative to order more decals.

**IMPORTANT!** It is always the owner's responsibility to comply with all applicable federal, state and local laws, rules and regulations regarding the ownership, operation and towing of your Wood-Mizer sawmill. All Wood-Mizer mill owners are encouraged to become thoroughly familiar with these applicable laws and comply with them fully while using or towing the mill.

Always properly dispose of all sawing by-products, including sawdust and other debris, coolant, oil, fuel, oil filters and fuel filters.

Safety instructions are listed in this section by the following operations:

- Blade Handling
- Sawmill Setup
- Sawmill Operation
- Sawmill Maintenance



## 1.1 Blade Handling



**DANGER!** Always disengage the blade and shut off the sawmill engine before changing the blade. Failure to do so will result in serious injury.



**WARNING!** Always wear gloves and eye protection when handling bandsaw blades. Changing blades is safest when done by one person! Keep all other persons away from area when coiling, carrying or changing a blade. Failure to do so may result in serious injury.



**WARNING!** Do not spin the blade wheels by hand. Spinning the blade wheels by hand may result in serious injury.

## 1.2 Sawmill Setup



**WARNING!** Chock the trailer wheels to prevent movement before unhitching it from the towing vehicle. Failure to do so may result in serious injury or death.

**WARNING!** Failure to put front outrigger down before moving cutting head from the rest position may result in serious injury.

**WARNING!** Securely fasten the feet of a stationary sawmill to the floor before operating the sawmill. Failure to do so may result in serious injury or death.

**WARNING!** Always make sure the trailer is supporting the sawmill frame when operating a sawmill with adjustable outriggers. Failure to do so may result in serious injury or death. The adjustable outriggers are intended to support the saw frame with assistance from the trailer.

**WARNING!** Do not set up the mill on ground with more than a 10 degree incline. If setup on an incline is necessary, put blocks under one side of the mill or dig out areas for outrigger legs to keep mill level. Setting up the mill on an incline could cause it to tip over, resulting in serious personal injury.



**CAUTION!** Changes in temperature could cause increased pressure in the blade tensioner and loss of fluid from the gauge. Release the blade tension when the mill is not in use to avoid damage to the tensioner.

## 1.3 Sawmill Operation



**DANGER!** Make sure all guards and covers are in place and secured before operating or towing the sawmill. Failure to do so may result in serious injury.

Be sure the blade housing and pulley covers are in place and secure. Use the safety retainer pin and cable to fasten blade housing covers.

**DANGER!** Always keep hands away from moving bandsaw blade. Failure to do so will result in serious injury.

**DANGER!** Stay clear of the area between the trailer axle and saw carriage. Failure to do so will result in serious injury.

**DANGER!** Keep all persons out of the path of moving equipment and logs when operating sawmill or loading and turning logs. Failure to do so will result in serious injury.

**DANGER!** Maintain a clean and clear path for all necessary movement around the mill and lumber stacking areas. Failure to do so will result in serious injury.

**DANGER!** Always be sure the blade is disengaged and all persons are out of the path of the blade before starting the engine or motor. Failure to do so will result in serious injury.

**DANGER!** Keep all persons out of the path of returning boards. Failure to do so will result in serious injury.



**WARNING!** Always disengage the clutch/brake mechanism whenever the sawmill is not cutting. Failure to do so may result in serious injury.

**WARNING!** Always wear eye, ear, respiration, and foot protection when operating the sawmill. Failure to do so may result in serious injury.



**WARNING!** Secure all loose clothing and jewelry before operating the sawmill. Failure to do so may result in serious injury or death.

**WARNING!** Always make sure log is clamped securely before sawing. Failure to do so may result in serious injury or death.

**WARNING!** Use ONLY water with the water lube accessory. Never use flammable fuels or liquids. If these types of liquids are necessary to clean the blade, remove it and clean with a rag. Failure to do so may result in serious injury or death.



**CAUTION!** Be sure the pivot rails, turning arm, clamp, and toe boards are below bed level before loading a log onto the bed. Failure to do so may result in machine damage or cause misalignment.

**CAUTION!** Before loading a log, be sure the cutting head is moved far enough forward so the log does not hit it. Failure to do so may result in machine damage.

**CAUTION!** Do not try to force the saw head beyond its upper and lower travel limits. Damage to the up/down system may result.

**CAUTION!** Do not use the blade guide arm knob to move the carriage head forward and backward. Damage to the blade guide arm may result.

**CAUTION!** Be sure to stop the blade when returning the carriage. This will not only prevent the blade from being pulled off and ruined by a wood sliver, but also will increase the life of the blade.

## 1.4 Sawmill Maintenance



**WARNING!** Always secure the cutting head with a chain or a brace before adjusting the up/down chain. The cutting head may fall, causing severe injury or death.

**WARNING!** Always secure the cutting head with a chain or a brace before adjusting the mast pads. The cutting head may fall, causing severe injury or death.

**CAUTION!** Reinstall the track wiper so that it lightly touches the track rail. If the wiper presses too firmly against the rail, it can cause the power feed to bind.

**CAUTION!** Never use grease on the mast rails as it will collect sawdust.

**CAUTION!** Do not use chain lube. It causes sawdust buildup in chain links.

**CAUTION!** Due to variations in the vertical mast, the pad spacing may vary throughout the travel of the saw head. Check the pad spacing at the top and bottom ends of the mast only. Pads adjusted too tight will cause premature up/down motor failure.

**CAUTION!** It is important that the lower stop bolts are properly adjusted to secure the carriage on the track rail. Failure to properly adjust the stop bolts can cause saw head damage, especially during mill transportation.



**WAŻNE!** With all screw joint without split lock washer or lock nylon nut, use the „Loctite 243” (blue, of average durability, for screw joints.)

# 1 Safety & General Information

## Belt Sizes

### 1.5 Belt Sizes

See Table 1-1. Belt sizes for the LT20 Series sawmill are shown.

Description	Belt Size	Wood-Mizer Part #
Motor Drive Belt E11 & E15 <sup>1</sup>	BX81	014819
Engine Drive Belt D22 & G18	2BX84	092697
Blade Pulley Belts	B57 <sup>2</sup>	P04185

TABLE 1-1

<sup>1</sup> E11 motor uses one, but E15 motor uses two BX81 belts.

<sup>2</sup> To insure proper blade tracking, use Goodyear, Dayco Super II, or Browning belts only.

### 1.6 Blade Sizes

See Table 1-2. Wood-Mizer TRU•SHARP™ offers three types of blades to provide efficient sawing for all models of sawmills. The engine/motor size of your sawmill and the type of wood you saw should determine which blade you choose for optimum performance.

Engine/Motor Size	Recommended Blade Type		
	Softwood	Medium Hardwood	Frozen Timber or Dense Hardwood
5 HP - 15 HP	B275IH1030 B275IH741030	B375IH929	B375IH929 <sup>1</sup>
16 HP or more	B376IH1030 B376IH741030	B275IH1030 B275IH741030 B376IH1030 B376IH741030 <sup>2</sup>	B375IH929 <sup>1</sup>
Electric Motor	B376IH1030 B376IH741030	B275IH1030 B275IH741030 B376IH1030 B376IH741030 <sup>2</sup>	B375IH929 <sup>1</sup>

<sup>1</sup> TRU•SHARP™ "F" 9° blades use a 9/29 profile (9° hook angle and 29° back angle) and are designed to cut frozen and/or extremely dense, hard-to-cut wood. Standard TRU•SHARP™ blades use a 10/30 profile.

<sup>2</sup> Customer may choose preferred blade.

TABLE 0-0

See *The Blade Handbook* for blade hook angle, tooth height, and tooth set specifications.

## 1.7 Cutting Capacity

See Table 1-3. The log size capacities of the LT20 series sawmill are listed below.

	Max. Diameter <sup>1</sup>	Max. Length <sup>1</sup>
LT20 S	71 cm	5.1 m (16' 8")
LT20 M	71 cm	6.4 m (21')
LT20 L	71 cm	8,4m

TABLE 1-3

<sup>1</sup> Maximum log capacity for a basic mill is 2000 Kg.

See Table 1-4. The performance capacity of the LT20 series sawmill is listed below. Peak cutting rates are measured in 12" (30 cm) wide red oak and represent the capability of the sawmill only. Rates based on using Tru-Sharp 1 1/4" x .042 blades.

Model	Linear Blade Speed	Maximum Cutting Speed
LT20 S/M G15	---	5.2 m/min.

TABLE 1-4

# 1 Safety & General Information

## Engine/Motor Specifications

### 1.8 Engine/Motor Specifications

See table 1-5. The power options available for the LT20 Series sawmill are listed below.

Engine/Motor Type	Manufacturer	Model No.	Power	Other Specifications
11HP Electric	Indukta	Sg 132S 2B HM	7,5kW	13,9A, 2800 RPM
15HP Electric	Indukta	PSg 132S-2 HM	11kW	20,2A, 2800 RPM
22HP Diesel	Kubota		22HP	3600 RPM

TABLE 0-0

See Table 1-6. The noise levels of the Wood-Mizer sawmills are listed below.

	Idle	Engaged
Sawmill Equipped With Gas Engine	95 dB (A)	98 dB (A)
Sawmill Equipped With Electric Motor	77.1 dB (A)	80.8 dB (A)

TABLE 1-6



## 1.9 Overall Dimensions

See table 1-7. The overall dimensions of the Wood-Mizer sawmills are listed below.

Model	Length <sup>1</sup>	Width <sup>2</sup>	Width Operating Position (Loading Arms Raised)	Height <sup>3</sup>	Weight	Weight w/Trailer
LT20SG15 w/Trailer	6,7 m	2 m	3,5 m	2,5 m	923 kg	1068 kg
LT20MG15	8 m	2 m	3,5 m	2,5 m	1013 kg	1158 kg
LT20LE15	10,8 m	2,3 m		2,3 m		2780 kg

TABLE 0-0

<sup>1</sup> Length from hitch to chain bracket.

<sup>2</sup> Width from fender to fender.

<sup>3</sup> Height from ground to mast. Placing head in maximum position will add to total height.

## 1.10 Chains

See Table 1-8. The load capacity of the chains is listed below.

	Load Capacity According to ISO Nr 08A-1
Up/Down Chain	2270KG

TABLE 1-8

## 1.11 Hydraulic System

See table 1-9. The specifications of the hydraulic system are shown below.

Hydraulic Pump	HYDROIRMA
Pressure Rating	15 MPa

TABLE 0-0

## 1.12 Sawdust Extractor Specifications

See table 1-10. The dust extractor specifications are given below.

<b>Maximum Capacity</b>	2300 m <sup>3</sup> /h
<b>Collector Inlet Diameters (in front of fan)</b>	2x140 mm
<b>Motor Power</b>	3 kW
<b>Number of Sacks for Waste</b>	2 pcs
<b>Total Capacity of Sacks</b>	0.25 m <sup>3</sup>
<b>Weight</b>	110 kg
<b>Conveying Speed When 10 m Long Hose Is Used</b>	20 m/s

**TABLE 0-0**

### 1.13 Components

See Figure 1-1. The major components of the Wood-Mizer LT20LAH are shown below.

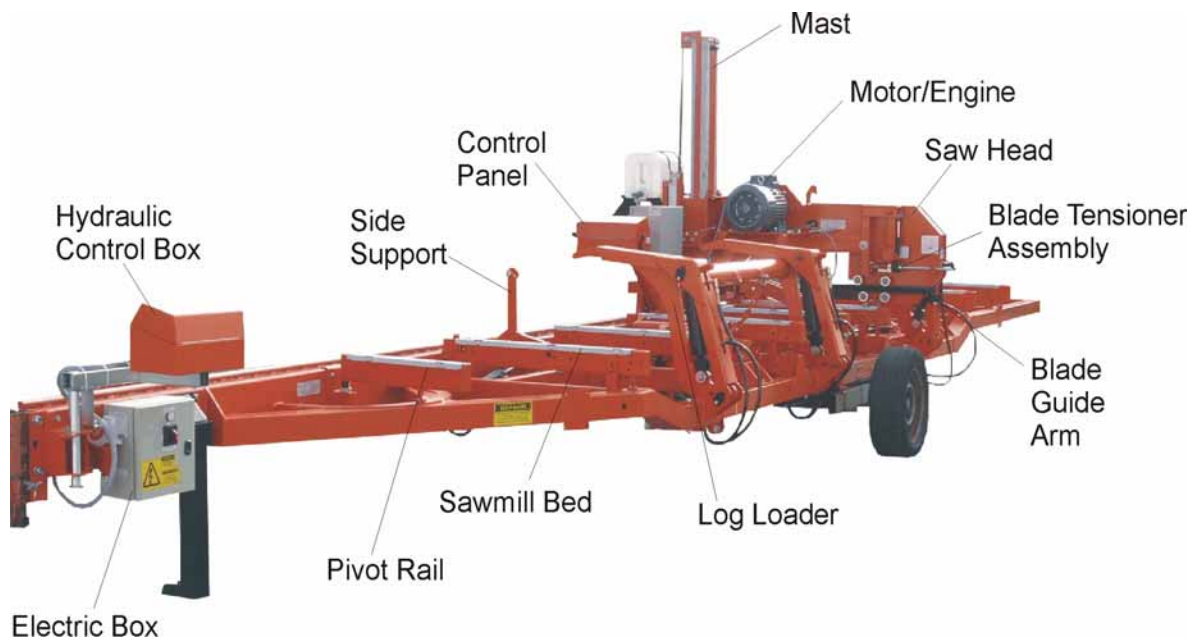

**FIG. 1-1**

## 1.14 Electrical Symbol Diagrams

See Figure 1-2. Electrical Symbol Diagram of the LT20LAH is shown below:

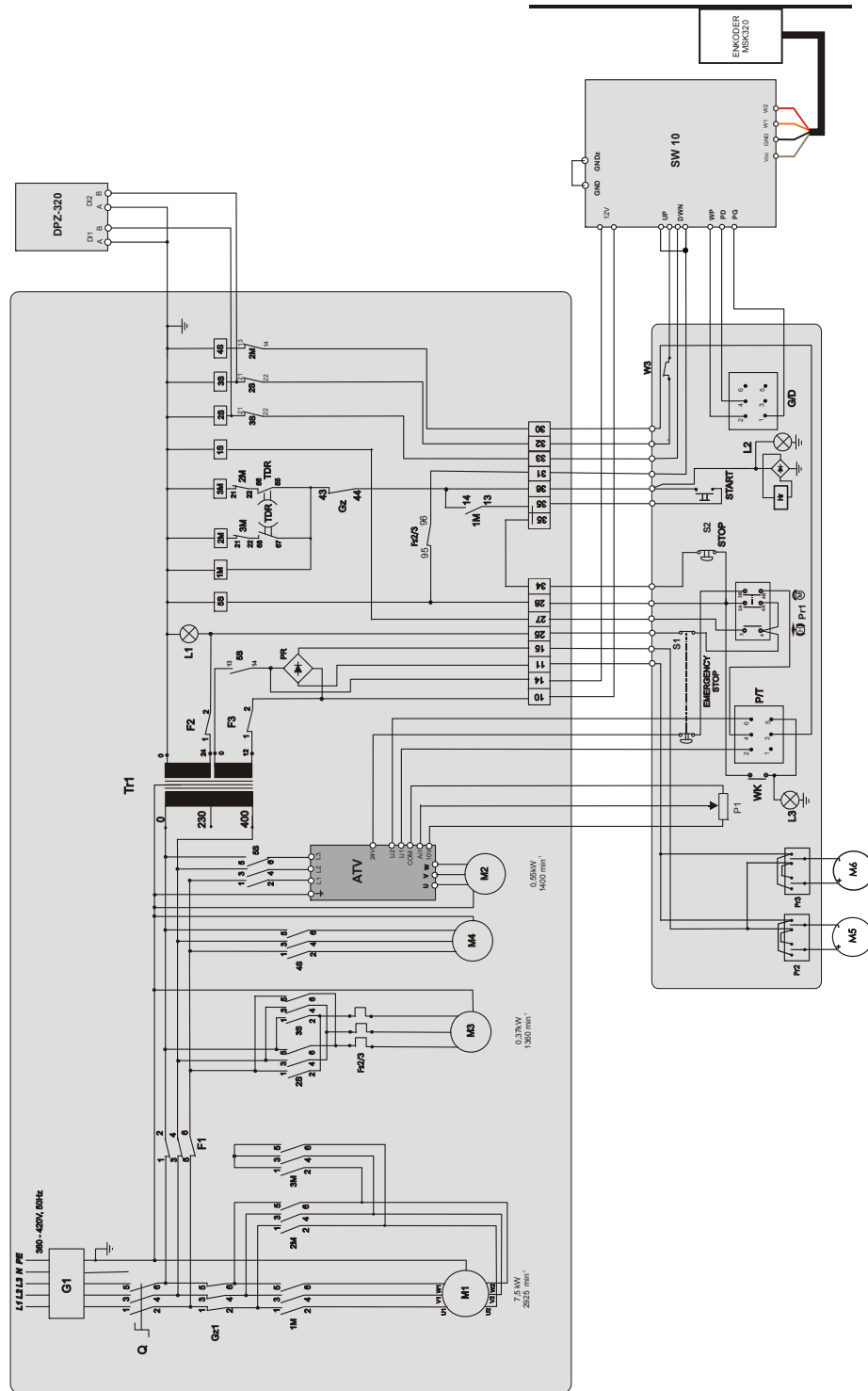

**FIG. 1-2**

**Diagram elements descriptions (See figure above):**

**Main electric box**

REF	Symbol	Name - type	Wood-Mizer Part No.
1	Q	Switch, ABB OT32 E3	088265
2	Gz1	Motor Circuit Breaker, Gz1 M21	084330
3	1M, 2M	Contactor, LC1 D18 B7	084306
4	3M	Contactor, LC1 D09 B7	084305
5	1S	Contactor, LC1 D0610 B7	084308
6	2S, 3S	Contactor, LC1 D0610 B7	084309
7	Fs2/3	Relay, Thermal LR2K 0308	084312
8	F1	Circuit Breaker, C60N C3P 6A 24348	091554
9	F2	Circuit Breaker, C60N 2A 24396	088278
10	TR1	Transformer, TMM63/A 240/380/415/24	088279
11	TDR1	Relay, Time Delay LAD S2	084037
12	L1	Control Light, M22 LED24V White	090448
13	Gz	Contact, GZ1-AN11 auxiliary	091611
14	IC5	Speed Controller, LG STARVERT SV008 IC5-1F	096226
15	S1	Emergency Stop Button, XB4 BS542	086556

# 1 Safety & General Information

## Electrical Symbol Diagrams

See Figure 1-3. Hydraulic electric diagram, LT20LAH.

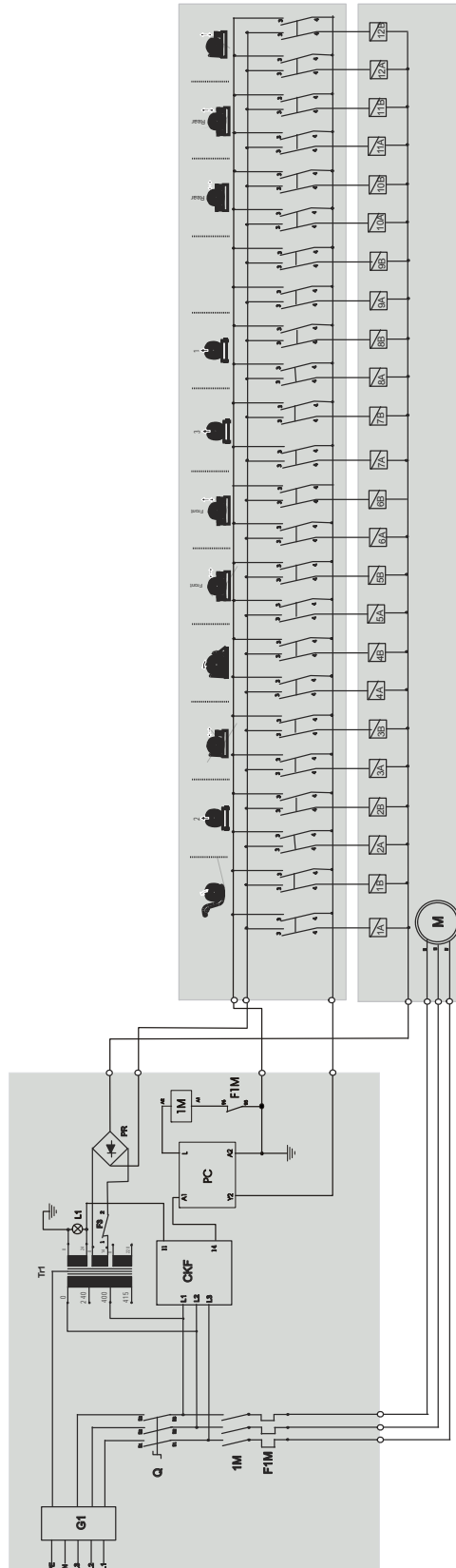

Re f	Symbol	Name - type	Syte-line number
1	1M	Contactator, LC1 K0910 P7	092736
2	L1	Light, white XB4-BVM1	084310
3	CKF	Phase Supply Control Relay, RM4TG20	084452
4	PC	Time relay, RE9 RA 11MW7	084453
5	F1	Switch, C60N1P 1A	084454
6	F1M	Thermal Overload Relay, LR2 K0316	084456
7	Q	Switch, ABB OT16E3	089801
8	G1	Plug, 16A 5P	E85239
9	W1	SWITCH, 2A 125V R-LEVER NO/NC/COM	014765
10	W2	Limit Switch, EVN2000 A	091742

## SECTION 2 SETUP & OPERATION

### 2.1 Sawmill Setup



**IMPORTANT!** Before starting to use the sawmill you have to meet the following conditions:

- Set up the sawmill on firm, level ground and level the sawmill. Secure the sawmill to the ground to prevent moving during operation. A concrete foundation or pads (rated to support 31 T/m<sup>2</sup> at each sawmill foot position) and 16mm anchored bolts are recommended.
- Under roof, the sawmill should always be operated with the sawdust collection system.
- The sawmill can be operated under roof only.
- The sawmill can be operated in temperature range from -15° C to 40° C only.
- The illumination at the operator's position should be at least 300lx.
- The sawmill operator's position is shown below.

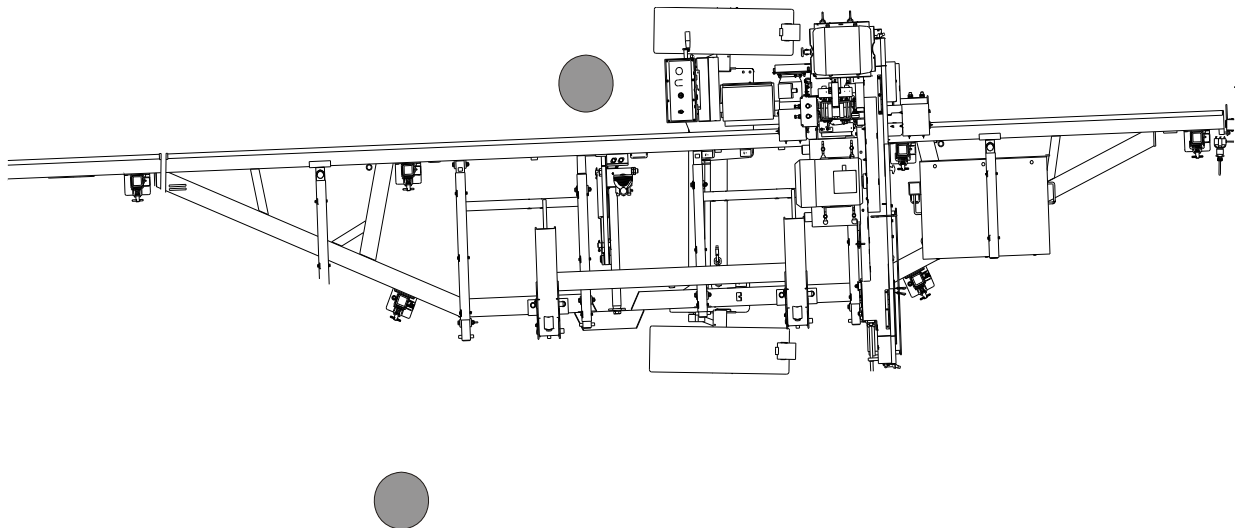



## 2.2 Stationary Sawmill Setup

See Figure 2-1. Set up the mill on firm footing and level by eye. Fasten the mill to the floor to prevent any creep after prolonged use.

**NOTE:** Make sure the unit is level before securing. It is possible to twist the mill frame by jacking one foot higher than the others.

 **WARNING!** Do not operate a stationary sawmill without the feet securely fastened to the floor.

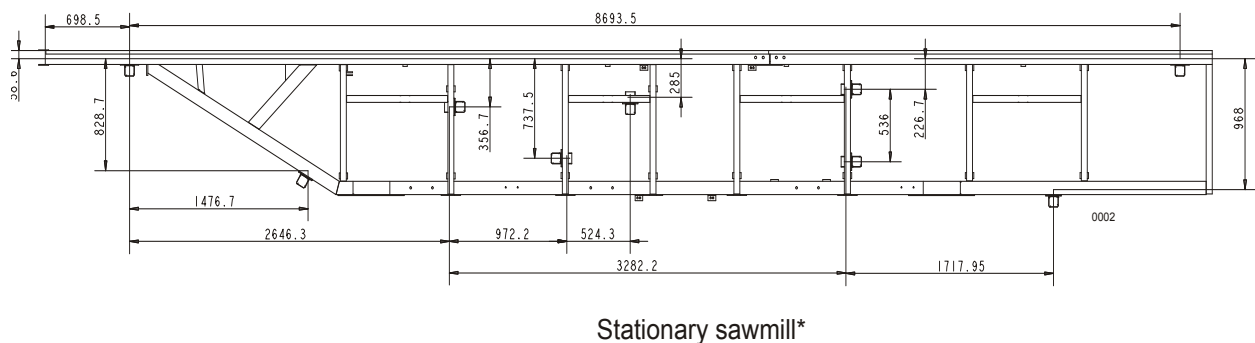

\*all diameters in millimeters

FIG. 2-1

1. Unhook the carriage safety chain, located at the bottom of the vertical mast.
2. Turn the key to the #2 position, to activate supply circuits. Use the up/down switch,  located on the right side of the control panel, to raise the saw head from the saw head rest pin. Pull the travel lock pin out, and swing the rest pin below bed level.
3. Use the power feed switch to move the cutting head toward the front end of the mill. Raise the two side supports that will prevent a log from falling off the side of the mill when loaded.



See Figure 2-2.

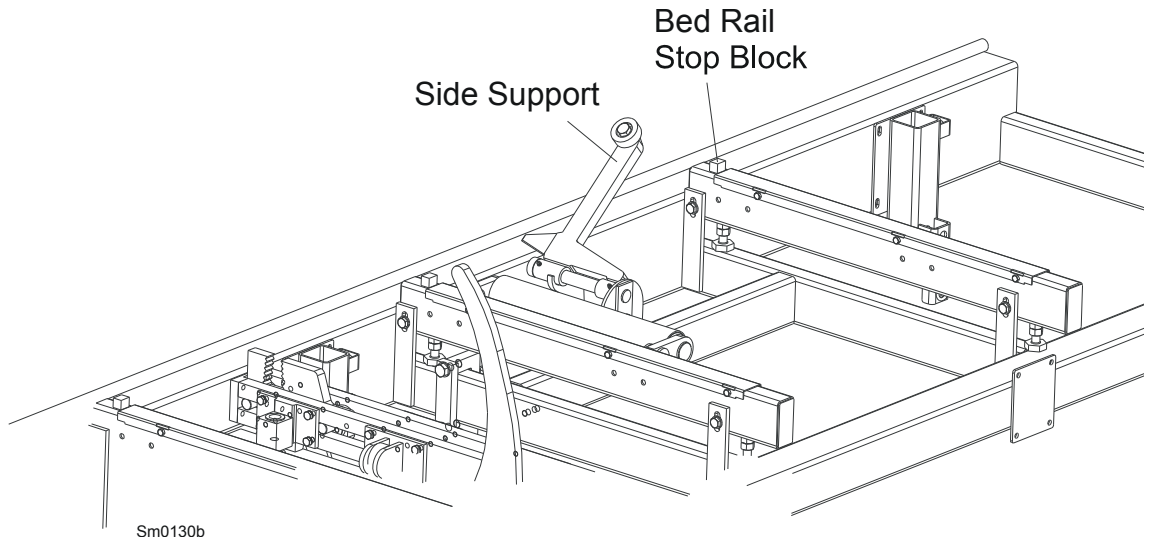

**FIG. 2-2**

## 2.3 Middle Track Cover

Before operating the sawmill do as follows:

1. Clean the upper and lower rails to remove any sawdust and rust preventives.
2. Unbolt and remove the middle track cover from its storage position.
3. Soak the felt wiper with Dexron III transmission fluid, 10W30 motor oil or 3-in-1 turbine oil.
4. Install the middle track cover so it fits against the rail and secure with two thumb screws.

See Figure 2-3.

Install the middle track cover and  
and secure with two thumb screws.

**FIG. 2-3**



**CAUTION!** Install the track cover so that it lightly touches the track rail. If the wiper presses too firmly against the rail, it can cause the power feed to bind.

## 2.4 Replacing The Blade



**DANGER!** Always shut off the sawmill motor before changing the blade. Failure to do so may result in serious injury.



**WARNING!** Always wear gloves and eye protection whenever handling bandsaw blades. Changing blades is safest when done by one person! Keep all other persons away from work area when changing blades. Failure to do so may result in serious injury.

Remove the blade housing cover(s) that are over the drive wheels. Turn the blade tension handle to release the blade tension until the wheel is pulled in and the blade is lying loose in the blade housing. Lift the blade out of the blade housing.

When installing a new blade, make sure the teeth are pointing the correct direction. The teeth should be pointing toward the operator side of the mill when you are looking at the blade below the blade guides. Install the blade so it is lying around the wheels.

Position 1 1/4" wide blades on the wheels so the gullet is 3.0 mm ( $\pm$  1.0 mm) out from the front edge of the wheel.

Close the middle blade housing cover.

Next, turn the tension handle until the blade is tensioned correctly.



**CAUTION!** Should you need to adjust the blade position, never grab the wheel arms to spin the idle-side blade wheel as your fingers can get pinched.

## 2.5 Tensioning The Blade

**See Figure 2-4.** Turn the blade tension handle clockwise until the tension gauge indicates the recommended tension. Check the blade tension occasionally when adjusting the cant control or while cutting. As the blade and belts heat up and stretch, the blade tension will change. Also, ambient temperature changes can cause tension to

change.

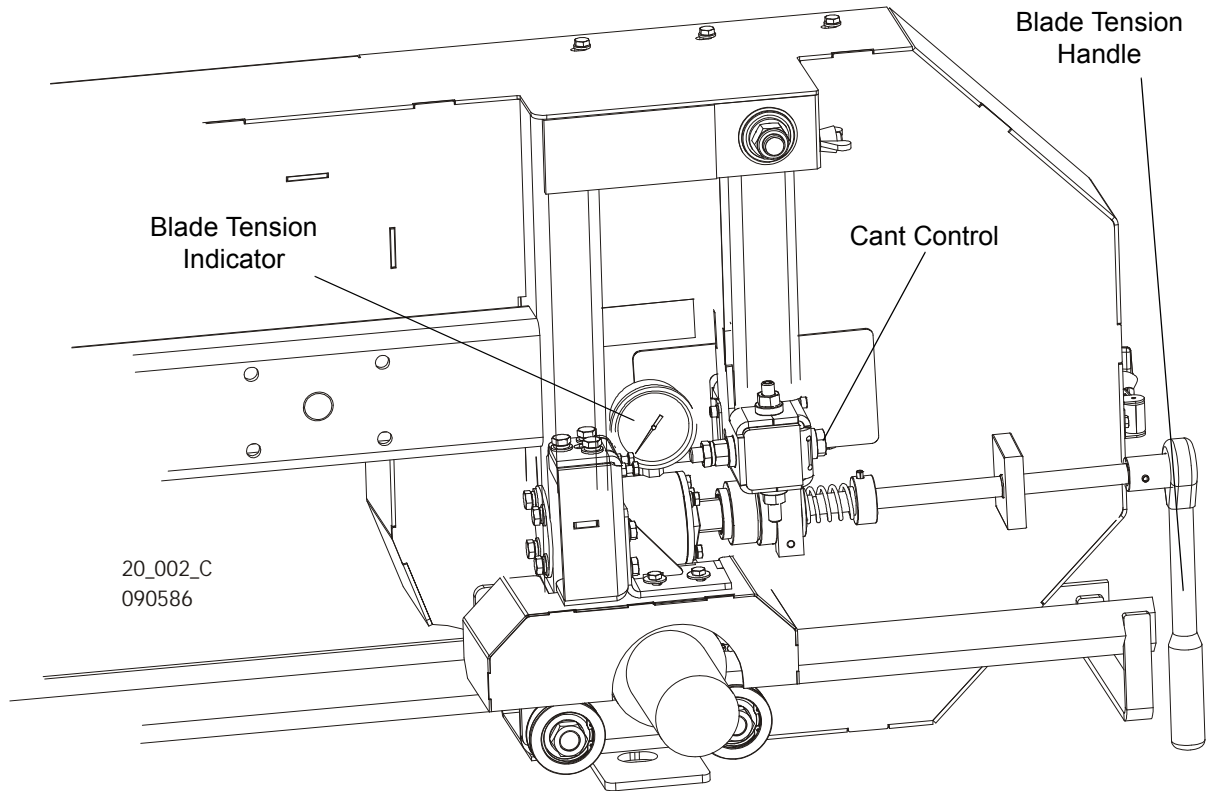

**FIG. 2-5**

**CAUTION!** Release the blade tension when the mill is not in use.

See **Table 2-1**. The recommended tension for different blades is shown below.

Blade Type	Blade Dimensions		Tension range	
	Width (mm)	Height (mm)	PSI	Bar
275	1.07	32	1015-1088	70-75
375	1.14	32	1088-1160	75-80
2735	1.07	35	1160-1233	80-85

**TABLE 2-1**

## 2.6 Tracking The Blade

1. Open the blade housing cover.
2. Turn the key switch to the "H" position.



3. Manually spin one of the blade wheels until the blade positions itself on the blade wheels.
4. Check if the blade is properly positioned on the blade wheels.

See **Figure 2-6**. Position 1 1/4" wide blade on the wheels so the gullet is 3.0 mm (0.12")  $\pm$  1.0 mm (0.04") out from the front edge of the wheel.

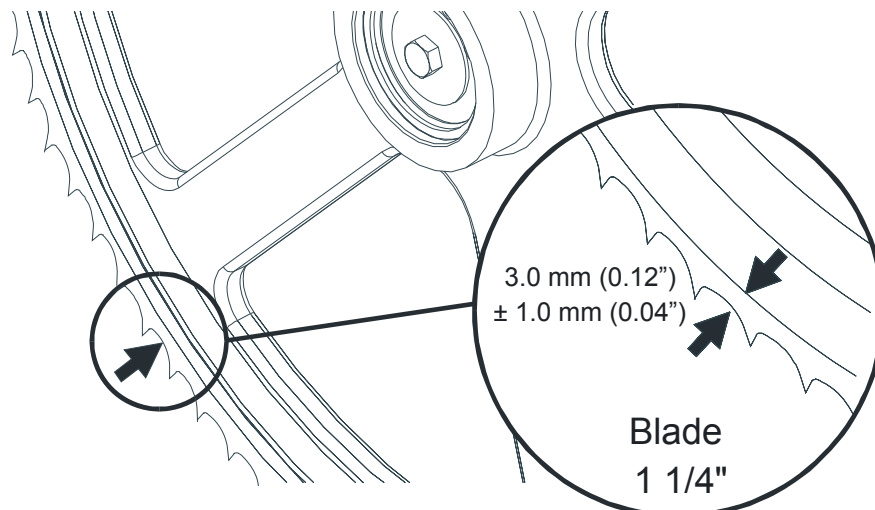

**FIG. 2-6**

5. Use the cant adjustment bolt, shown in **Figure 2-5** to adjust where the blade travels on the blade wheels.

To move the blade out on the blade wheel, turn the cant adjustment bolt clockwise. To move the blade in on the blade wheel, turn the bolt counterclockwise.

6. After adjusting the tilt of the blade wheels with the cant adjustment bolt, tension the blade properly.
7. Close the blade housing cover.



**DANGER!** Make sure all guards and covers are in place and secured before operating or towing the sawmill. Failure to do so may result in serious injury. Be sure the blade

housing and pulley covers are in place and secured. To secure, use the detent pin and wire supporting the blade covers.

**CAUTION!** After aligning the blade on the wheels, always check the blade guide spacing and location. (See Section 5 for more information.)

## 2.7 Starting The Motor

See the appropriate manual supplied with your specific motor configuration for starting and operating instructions.



**IMPORTANT!** For safe operation of the sawmill, one person is sufficient, however in case of manual collection of sawn material, at least two persons shall be assigned to these activities in order to not exceed the manual load lifting standard.



**CAUTION!** Before starting the machine, the operator must warn the people who are nearby about the intention of starting the machine.



**IMPORTANT NOTE!** The sawmill shall be operated only by a person of age, who has adequate training and is in good health condition confirmed by a medical certificate.



**IMPORTANT!** When starting the machine for the first time, check that main motor rotation direction is as indicated by the arrow located on the motor body (fan guard). If the rotation direction is incorrect, invert the phases in the phase inverter located in the power socket (electric box). Setting the phases in the phase inverter correctly will ensure correct rotation directions of all sawmill motors.



**DANGER!** Make sure all guards and covers are in place and secured before operating or towing the sawmill. Failure to do so may result in serious injury. Be sure the blade housing cover is in place and secured.

**DANGER!** Do not start the motor when the clutch/brake lever is in the engaged position. Always be sure the blade is disengaged and all persons are out of the path of the blade before starting the motor.



**WARNING!** Always wear eye, ear, respiration and foot protection when operating the machine. Secure all loose clothing and jewelry before operating the sawmill. Failure to do so may result in serious injury.



**CAUTION!** The sawdust extractor (according to the specification given in [Section 1.12 Sawdust Extractor Specifications](#)) must be connected to the sawdust chute and started before operating the sawmill.



Before starting the machine in a new location, at least once a year or after each repair, checks of insulation resistance and electric shock protection of the electrical system shall be performed. Performance of electrical systems checks and adequate measurements shall be ordered to an electrician having appropriate measurement qualifications.

The electric box should be protected from the dust. Regularly disconnect power and clean the electric box inside from the sawdust. Do not operate or leave sawmill with electric box door open.



**CAUTION!** Hazardous voltage inside electric box (even disconnected with the main disconnect switch) and at the electric motor, can cause shock, burns or death. Always disconnect power supply before servicing!

## 2.8 Hydraulic Control Operation

The hydraulic control levers become operational when contacts located at the bottom of the carriage touch the power strip on the frame tube. The hydraulic control levers will only work when the cutting head is close enough to the front end of the mill to touch the power strip.

**See Figure 2-7.** Sawmills with hydraulic control have eleven control levers to load, clamp, turn and level logs.

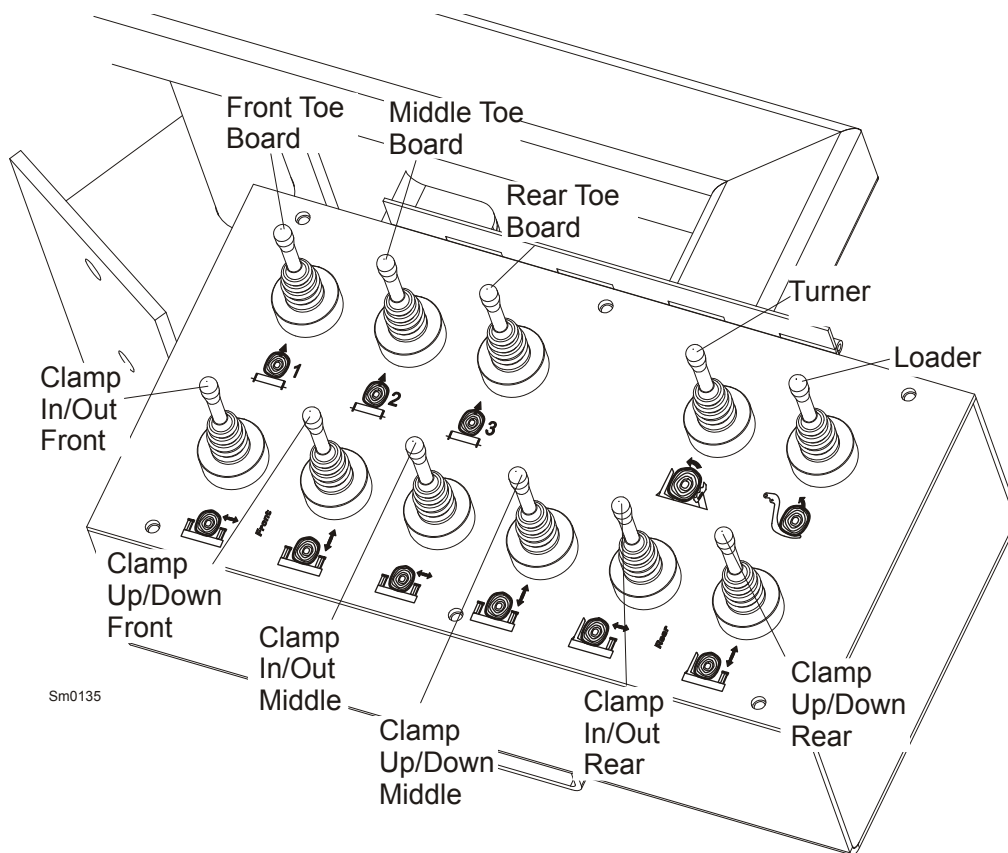

FIG. 2-7

Use the hydraulic control levers to get the mill ready to load a log.



**DANGER!** Keep all persons out of the path of moving equipment and logs when operating sawmill or loading and turning logs.

1. Move the clamp out and down so it will not get in the way of logs being loaded onto the bed.



Lower the clamp in/out lever to move the clamp out toward the loading side of the sawmill.



Lower the clamp up/down lever to lower the clamp below bed level.

2. Raise the log loader lever to extend the legs of the log loader out as far as they will go.



3. The chain securing the log loading arm to the log turner arm will be tight. Raise the log turner lever to raise the turner arm until there is slack in the chain.



4. Unchain the loading arm from the turner arm.

5. Lower the turner lever to completely lower the turner arm. Notice that after the turner arm is all the way down, the side support braces will begin to lower. Release the turner lever after the turner arm is lowered, but before the side supports begin to lower. This stops the log being loaded from damaging the turner and/or falling off the side of the sawmill.



6. When raising the turner lever, the side supports rise first. After reaching a fully vertical position, the turner arm will engage and start to rise.

7. Manually lower the log loader so the legs rest on the ground.



**CAUTION!** Be careful when manually lowering the log loader. Do not drop the loader onto the ground or perform any action which might break the velocity fuse valves on the loader cylinders. These valves control hydraulic flow and are necessary to prevent the loading arm from collapsing during use.

8. Lower the loader lever to lower the loading arm as far as it will go. Logs must be rolled onto the loading arm one at a time for loading onto the bed of the mill.



9. The front and rear toe boards should be below bed level. Once a tapered log has been loaded, the front or rear end of the log may be lifted to parallel the heart of the log to the path of the blade.



The front toe board is raised by lifting the front toe board lever up. The rear toe board is raised by lifting the rear toe board lever up. Once a flat has been made and the log is ready to be turned, push the appropriate toe board lever down to lower either toe board until it falls below the level of the bed.

## 2.9 Loading, Turning, And Clamping Logs



**CAUTION!** Be sure the pivot rails, turning arm, clamp, and toe boards are below bed level before loading a log onto the bed. Make sure that the log is placed on the bed in a way precluding destruction of the manual winch during loading. Also, be sure the cutting head is moved far enough forward so the log does not hit it.

### To Load Logs:

1. Move a log up to the loading arm. Use cant hooks or loading equipment to move the logs to the foot of the loading arms.
2. Roll the log onto the loader so that it is approximately centered with the sawmill bed. The log turner will operate much easier if the log is centered on the sawmill bed.
3. Raise the loader lever to raise the log onto the sawmill bed. Simply let the loader rise until the log rolls onto the mill bed.



4. Lower the loading arm. Leave the loading arm about halfway up while squaring the log. This will stop the log from rolling off the side of the mill.



**WARNING!** Always leave loading arm halfway up while log is on sawmill bed. Failure to do so may result in serious injury or death.

**NOTE:** Logs also may be loaded onto the mill with a tractor or other equipment specifically designed for that purpose.

5. Raise the clamp up to prevent the log from rolling off the bed.
6. Raise the clamp up/down lever.



### To Turn Logs:

1. Raise the turner lever to engage the log turner arm. Let the arm rise until it touches the log and starts to turn it.



2. Spin the log against the side supports until it is turned the way you want it for the first cut. If you want to turn the log more, do the following steps.

3. Engage the clamp by raising the clamp in/out lever. Clamp the log against the side supports.



4. Lower the turner lever to lower the turner arm below the log.



5. Raise the turner arm to get a new bite on the log.
6. Disengage the clamp.
7. The log can be turned now. Repeat steps 4 through 7 until the log is turned as desired.

#### **To Turn Logs (Optional Procedure For Hydraulic Mills Only)**

If you are turning a small cant on a Super Series mill, you may opt to use the clamp to turn the cant.

1. Lower the clamp up/down lever to lower the clamp below bed level.
2. Raise the clamp in/out lever to move the clamp in, beneath the edge of the cant.
3. Raise the clamp up/down lever to raise the clamp and flip the cant.

#### **To Clamp Logs**

1. Raise the clamp in/out lever and clamp the log against the side supports.



2. Lower the turner lever until the turner arm falls below the bed.



3. When the turner arm is lowered all the way, the side supports will begin to lower. Back the clamp off slightly, and let the side supports come down until they are positioned below the level of your first few cuts.

## 2

## SETUP & OPERATION

### *Loading, Turning, And Clamping Logs*

---

#### **To Level A Tapered Log**

Use the toe board lever(s) to raise either end of a tapered log, if desired.



Raise the appropriate lever to raise the front or rear toe board until the heart of the log measures the same distance from the bed rails at each end of the log.

## 2.10 Up/Down Operation

1. Install a blade and check for correct blade tension. ([See Section 2.4](#)).
2. Set the cutting head to the desired height. (The blade height scale shows the height of the blade above the bed rails.)



**See Figure 2-8.** The up/down switch is located on the right side of the control panel. Push the switch up to raise the cutting head; push the switch down to lower the cutting head. Hold the switch in position until the cutting head reaches the desired height, then release.

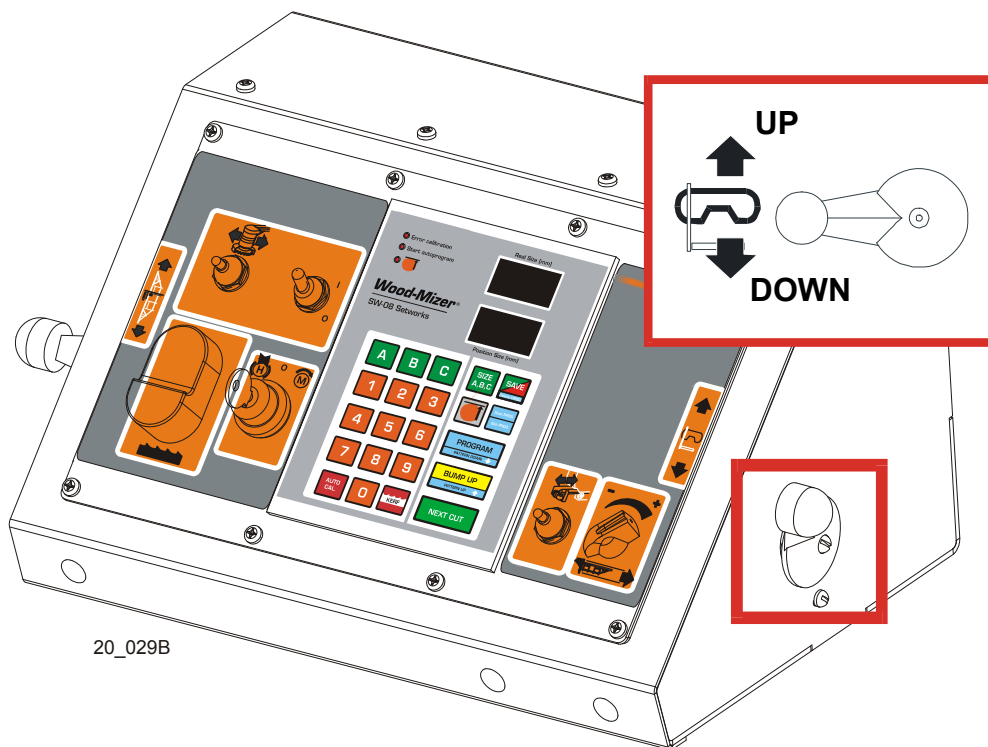

**FIG. 2-8**

**See Figure 2-9.** The up/down switch is designed to return to the neutral position when released. If the switch remains engaged, manually move it to the neutral position. Repair the switch. ([See Section 4.2](#)).



**CAUTION!** DO NOT try to force the carriage above the 35" (88 cm) mark or below the 1" (2.54 cm) mark. Damage to the up/down system may result.

## 2.11 Blade Guide Arm Operation

1. The outer blade guide should be adjusted so that it is about 1" (25.4 mm) from the log.
2. If necessary, use the blade guide arm crank to adjust the outer blade guide. Turn the crank clockwise to move the blade guide arm in, counterclockwise to move the arm out.

See Figure 2-10.

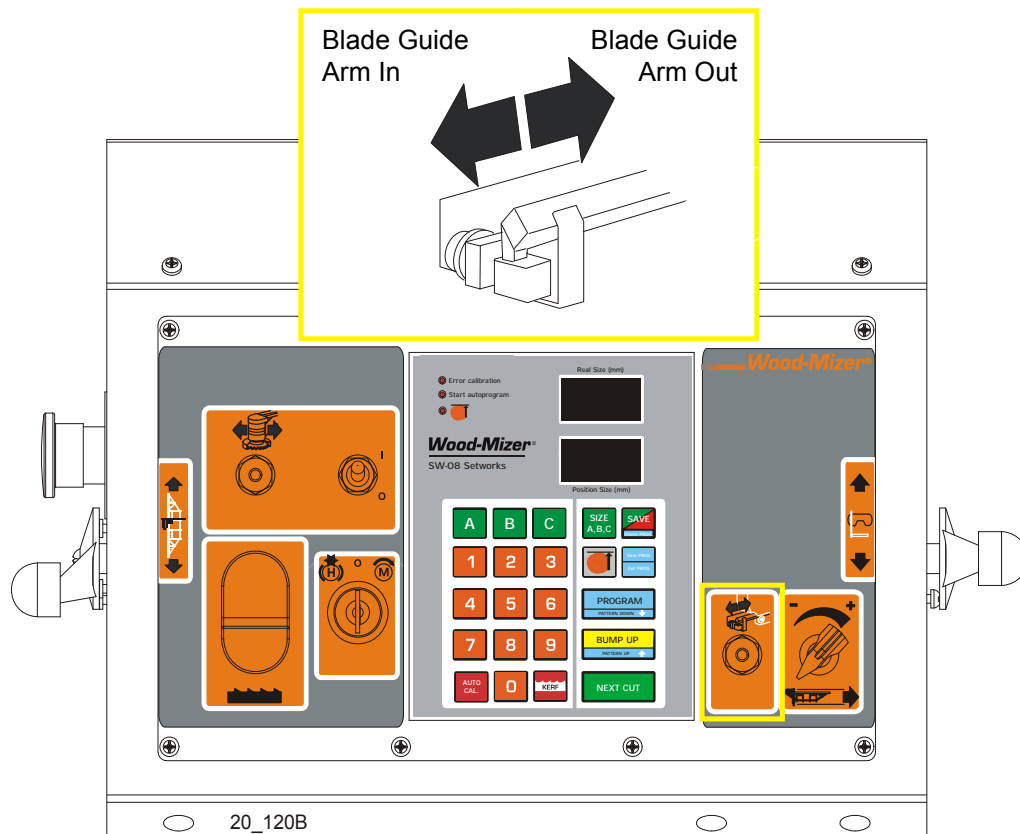
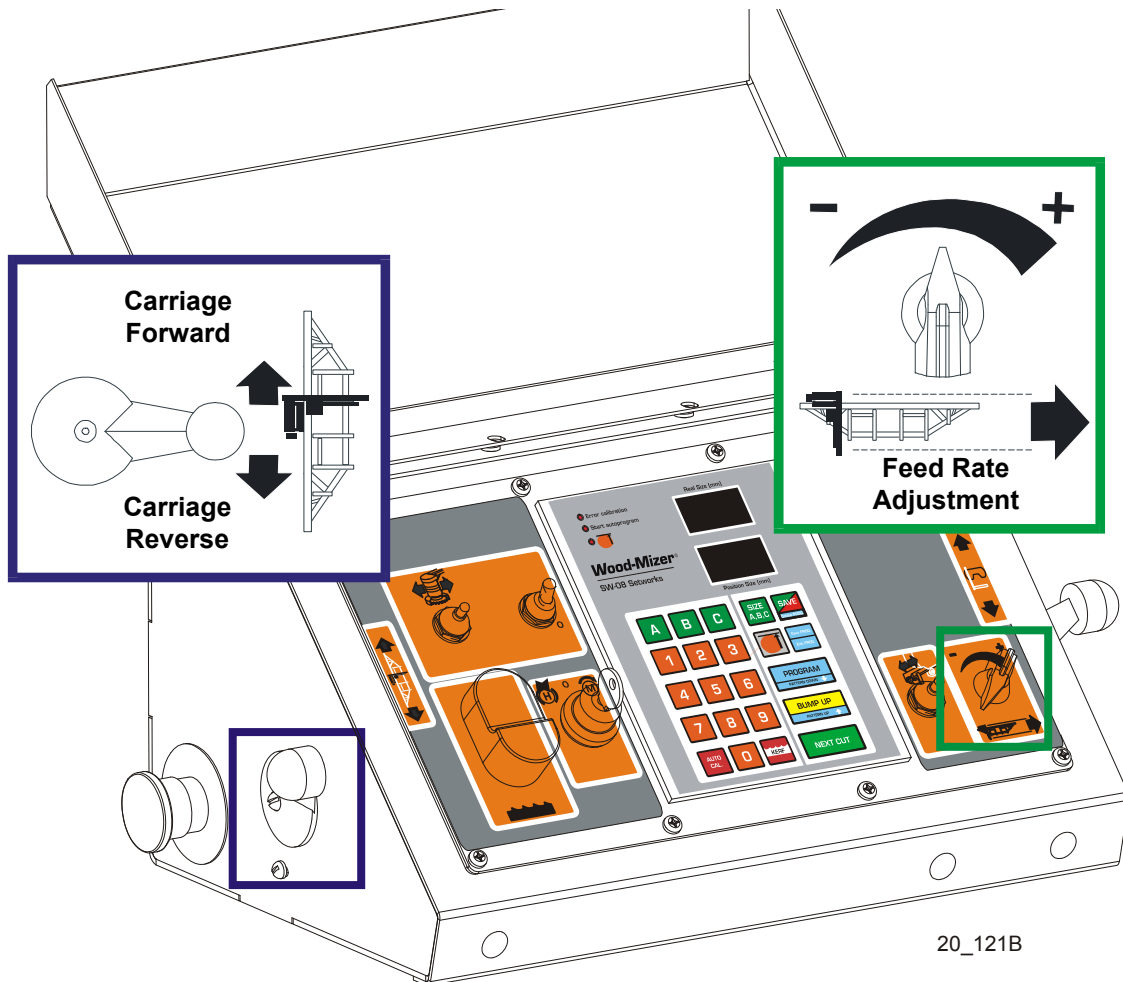

FIG. 2-10



## 2.12 Power Feed Operation

See Figure 2-11. The power feed system moves the carriage forward and backward by using two switches on the control panel.



20\_121B

FIG. 2-11

### See Figure 2-12. Carriage Feed Rate



The carriage feed rate switch controls the speed at which the carriage travels forward. Turn the switch clockwise to increase speed. Turn it counterclockwise to reduce speed.

Carriage Forward and Reverse

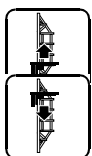

The power feed switch controls the direction in which the carriage travels. Turn the switch upward to move the carriage forward. Turn the switch down to move the carriage backward.

**NOTE:** Always disengage the blade before returning the carriage and raise the carriage slightly to make sure the blade clears the log.

The middle position (shown in the figure above) is the neutral position. The power feed switch is designed to return to the neutral position when released. If the switch remains engaged, manually move it to the neutral position. Repair the switch ([See Section 4.2](#)).



**WARNING!** Be sure the power feed switch is in the neutral position before turning the key switch to the ON position (#1 or #2). This prevents accidental carriage movement which may cause serious injury or death.

### Feed Rate

**HINT:** To get a straight cut in the first part of the log, feed the blade into the log at a slow speed. This stops the blade from flexing. Turn the carriage feed rate switch to a slow speed until the whole width of the blade has entered the cut. Then use the carriage feed rate switch to increase the feed rate as desired. Maximum feed rate varies with width and hardness of the wood. Over-feeding results in motor and blade wear, and also produces a wavy cut.



1. Always disengage the blade before returning the carriage and raise the carriage slightly over the log.



Stop the carriage at the end of the cut by turning the carriage feed rate switch counterclockwise until the carriage stops moving.

2. ( **Sawmills with gas engines** ) Using the clutch/brake lever, disengage the blade. This will stop the blade and drop the motor to idle. Remove the board from the log.
3. ( **Electric sawmills** ) Using the STOP button, disengage the blade. This will stop the blade. Remove the board from the log.



**CAUTION!** Be sure to stop the blade when returning the carriage. This will not only prevent the blade from being pulled off and ruined by a wood sliver, but also will increase the life of the blade. [See Section 2.14](#) for additional operation for Super Sawmills.



Return the carriage to the front of the mill by turning the power feed switch down. The power feed motor will bypass the carriage feed rate switch and the carriage will automatically return at the fastest speed available. **Always disengage the blade before returning the carriage for the next cut.**



**CAUTION!** Do not use the blade guide arm crank to move the carriage forward and backward. Damage to the blade guide arm may result.

5. Make sure that the blade does not catch on the end of the log. Raise the carriage slightly to make sure the blade clears the log when returned. **HINT:** Try to stop the blade while the heel of the blade is still on the log. Then bring the carriage back without adjusting the blade up. This lets you keep the blade at the current height setting so you can make the next blade height adjustment more quickly.



**DANGER!** Stay clear of the area between the trailer axle and saw carriage. Failure to do so will result in serious injury.

## 2.13 Cutting The Log

The following steps guide you through normal operation of the Wood-Mizer sawmill.

1. Once the log is placed where you want it and clamped firmly, position the blade close to the end of the log.
2. Use the blade height scale to determine where to make your first cut ([See Section 2.16](#)). Set the blade to the desired height with the up/down switch. Make sure that the blade will clear both side supports and the clamp.
3. Adjust the outer blade guide to clear the widest section of the log using the blade guide arm crank.



Make sure all guards and covers are in place. Engage the blade. To do this, turn the key switch to the "M" position and press the START button.

5. To prevent sap buildup on the blade, open the water bottle valve so that water flow to the blade. [See Section 2.19](#).
6. Feed the blade into the log slowly ([See Section 2.12](#)). Once the blade completely enters the log, increase the feed rate as desired. Always try to cut at the fastest speed you can while keeping an accurate cut. Cutting too slowly will waste blade life and lower production!
7. As you get to the end of the log, slow down the feed rate. When the teeth exit the end of the log, turn the power feed switch to the neutral position. Then disengage the blade using the STOP button. Remove the board that you have just cut from the log.
8. Use the power feed switch to move the carriage to the front of the mill. Always disengage the blade before returning the carriage for the next cut.
9. Repeat until the first side of the log is cut as desired. Set aside the usable flitches (boards with bark on one or both sides). You can edge them on the mill later.
10. Lower the toe boards, if they were used. Remove the clamp and turn the log 90 or 180degrees. Make sure the flat on the log is placed flat against the side supports if turned 90degrees. Make sure it is placed on bed rails if turned 180 degrees. If the log was turned 90degrees and you are using toe boards to compensate for taper in the log, raise the front or rear toe board again on the second side of the log until the heart is parallel with the bed.
11. Repeat the steps used to cut the first side of the log until the log is square. Cut boards from the remaining cant by adjusting the blade height for the thickness of boards that you want.

**Example:** Remember that the blade cuts a 1/16 - 1/8" (1.5-3.0 mm) wide kerf. If you want 1" (25.4 mm) thick boards, lower the carriage 1 1/16 - 1 1/8" (27-28.6 mm) for each board.

## 2.14 Edging

The following steps guide you through edging boards on the Wood-Mizer sawmill.

1. Raise the side supports to ~ the height of the flitches, or the boards that need to be edged.
2. Stack the flitches on edge against the side supports.
3. Clamp the flitches against the side supports. (Wider flitches should be placed to the clamp side. When they are edged, flip them over to edge the second side without disturbing the other flitches or without having to pull them from the middle of the stack.)
4. Adjust the blade height to edge a few of the widest boards.
5. Loosen the clamp and turn the edged boards over to edge the other side.
6. Repeat steps 2-4.
7. Loosen the clamp and remove the boards that have good clean edges on both sides. Clamp the remaining flitches and repeat steps 2-5.

## 2.15 Additional operation for Super sawmills

In order to increase effectiveness of operation, it may be required to leave the blade turned on when returning the saw head. (The standard procedure of sawmill operation requires turning the blade off when returning the saw head, in order to increase the strength of the blade and to save fuel.)



**CAUTION!** When leaving the sawmill with the blade turned on for a moment to increase the production, it should be checked whether the people are in a safe distance.



**CAUTION!** When leaving the sawmill with the blade turned on, the saw head must be raised above the log before returning the saw head.

## 2.16 Blade Height Scale

See Figure 2-13. The blade height scale is attached to the cutting head frame. It includes:

- a blade height indicator
- metric scale
- an inch scale.

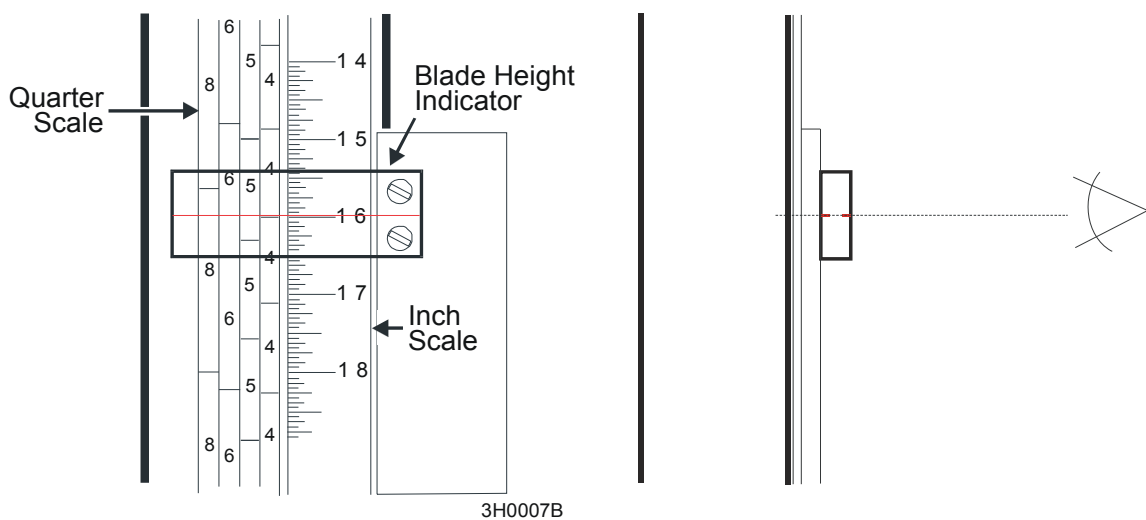

FIG. 2-13

Scales are fastened to the saw head, and moving up and down with the saw head. Blade height indicator is fixed.

### Blade Height Indicator

The blade height indicator has two horizontal, red lines on both sides. Readings should be taken with eyes level with the indicator, when the two red lines are in line. This will allow to avoid the parallax error (different scale readings depending on the angle of vision).

### The Inch Scale

The horizontal red line on the blade height indicator shows how many inches the bottom of the blade is above the bed of the mill. If you know the height of your blade at each cut, you can determine the thickness of lumber you are sawing.

# 2

## SETUP & OPERATION

### Blade Height Scale

**Example:** You want to cut 1" (25 mm) random width boards from a log. Position the blade for the first cut. Move the carriage to an even measurement on the inch scale. Make a trim cut. Return the carriage for the second cut and lower it 1 1/8" (28 mm) below the original measurement. (The extra 1/8" (3 mm) allows for saw kerf and shrinkage of the lumber.)

The yellow area on the scale identifies where the blade could encounter a side support or log clamp. Check that these items are below the blade level before sawing.

### The Quarter Scale

**See Figure 2-2.** The quarter scale is provided with four sets of marks. Each set represents a specific lumber thickness. Saw kerf and shrinkage allowance are included, but actual board thickness will vary slightly depending on blade thickness and tooth set.

To choose which scale to use, determine what finished thickness you want to end up with. The Grade Hardwood Quarter Scale provides thicker finished boards usually required by commercial buyers. The Standard Quarter Scale allows for kerf and shrinkage of finished boards suitable for most custom applications. Always check with your customer before you saw to determine what actual finished thickness is required.

Standard Quarter Scale	
Scale	Actual Board Thickness
4/4	25 mm (1")
5/4	32 mm (1 1/4")
6/4	38 mm (1 1/2")
8/4	51 mm (2")

Grade Hardwood Quarter Scale	
Scale	Actual Board Thickness
4/4	29 mm (1 1/8")
5/4	35 mm (1 3/8")
6/4	41 mm (1 5/8")
8/4	54 mm (2 1/8")

TABLE 0-0

To use the quarter scale, look at the blade height indicator. Line up the horizontal red line on the indicator with the nearest mark on the scale you want to use. Make a trim cut. When you return the carriage for a second cut, lower the carriage to the next mark on the scale. This mark shows where the blade should be positioned to cut a certain thickness of lumber, without having to measure on the inch scale.

**Example:** You want to cut 1" (25 mm) (4/4) random width boards from a log. Position the blade for the first cut. Adjust the quarter scale so a 4/4 mark is aligned with the red line on the indicator. Make a trim cut. Return the carriage for the second cut. Now, instead of having to measure down 1 1/8" (29 mm) on the inch scale, you can simply lower the blade so the indicator is aligned with the next 4/4 mark on the quarter scale. Turn the log 90 degrees and repeat.



## 2.17 Water Lube Operation

The Water Lube System keeps the blade clean. Water flows from a 5-gallon (18.9 liter) bottle through a hose to the blade guide where the blade enters the log. A valve in the bottle cap controls the amount of water flow.

**See Figure 2-14.** Open the valve on the water bottle to start water flow. A stream of water flow to the blade only when the main motor is turned on.

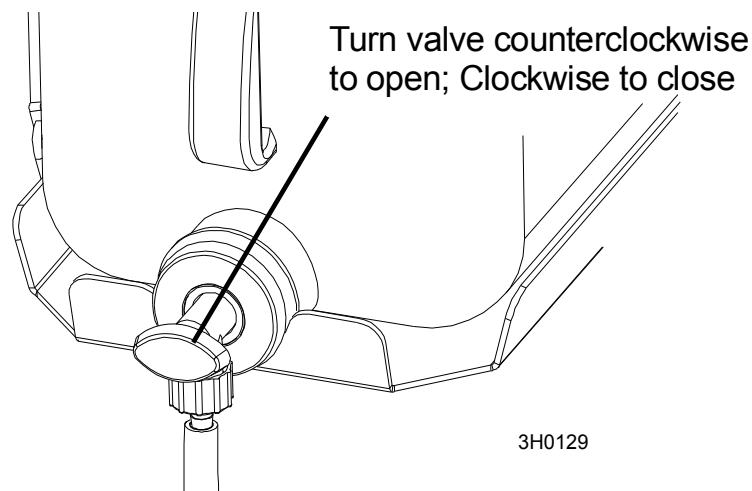

FIG. 2-14

Super sawmills are supplied with solenoid valve which automatically activates water flow when the saw head is moving forward. The water flow stops when the power feed switch moves to the neutral position.

Not all types of wood require the use of the Water Lube System. When it is needed, use just enough water to keep the blade clean. This saves water, and lowers the risk of staining the boards with water. Usual flow will be 1-2 gallons (3.8-7.6 liters) per hour. A squirt of liquid dishwashing detergent in the water bottle will help clean the blade when cutting wood with a high sap content.



**WARNING!** Use ONLY water with the water lube accessory. Never use flammable fuels or liquids. If these types of liquids are necessary to clean the blade, remove it and clean with a rag. Failure to do so may result in serious injury or death.

Before removing the blade, start the motor with the START button. Let the blade spin with water running on it for about 15 seconds. This will clean the blade of sap buildup. Wipe the blade dry with a rag before storing or sharpening.

If you are sawing in freezing temperatures, remove the water lube bottle from the sawmill when done sawing and store it in a warm place. Blow any remaining water from the water

# 2

## SETUP & OPERATION

### *Water Lube Operation*

---

lube hose.

To remove water from the water valve in sawmills of the Super series, turn the key to the (#2) position, turn the feed rate dial to the "0" position and set the forward/backward switch to the forward direction. Blow any remaining water from the hose and valve. Set the forward/backward switch to the neutral position and turn the key switch to the (#0) position.

## 2.18 Preparing The Sawmill For Towing

The Wood-Mizer trailer package makes transporting your sawmill easy and convenient. To get your sawmill ready for towing, follow these instructions.

1. Move the cutting head to the front end of the sawmill. Raise the rear outriggers.
2. Move the cutting head to the travel position over the rear bed rail.
3. Position the hole in the cutting head over the travel rest pin.
4. Lower the cutting head until it is seated firmly on the rest pin.
5. Continue lowering the head 3/4" (19 mm) until it contacts the stop bolt located on the mast.



**CAUTION!** It is important that the stop bolt is properly adjusted to secure the carriage on the track rail. Failure to properly adjust the stop bolt can cause cutting head damage, especially during mill transportation.

6. Engage the clutch/brake lever. This will stiffen the drive belt and will prevent the motor from vibrating during transporting the sawmill. After reaching the target location, disengage the clutch to avoid deformations of the drive belt.
7. Hook the carriage safety chain attached to the main bed tube, behind the trailer to the bracket located near the lower track roller.
8. Manually lift the log loader and secure it with the safety chain.

See Figure 2-15.

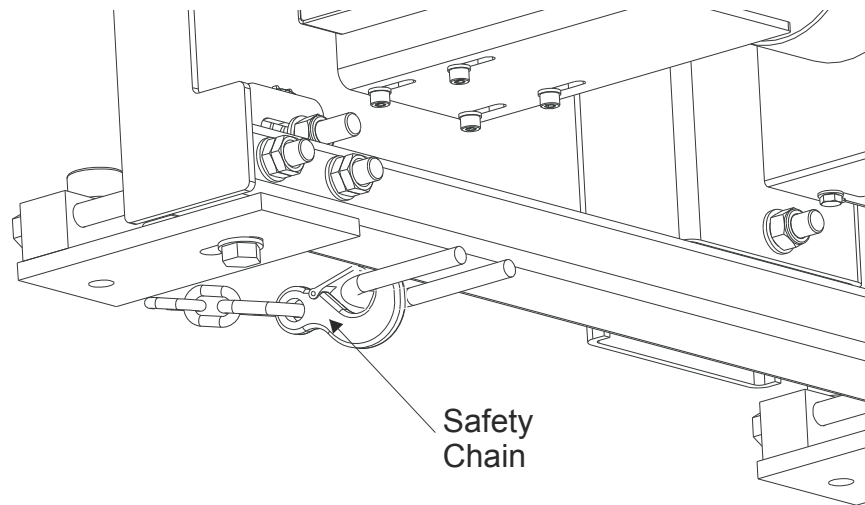

FIG. 2-15



**CAUTION!** Check to be sure that the carriage safety chain is secured before towing the sawmill. Failure to properly secure the cutting head can result in severe machine damage. Be sure the blade housing and pulley covers are in place and secured. To secure, use the detent pin and wire supporting the blade covers.

9. Remove all loose objects from the bed of the mill. Store the cranks for toe boards in the brackets provided at the rear of the mill. Wind the winch cable. Remove the crank.
10. Place both fenders in the slots located behind the trailer tires. Raise all but the very front outrigger.

See the trailer operator's manual for specific information regarding hitch operation and towing the sawmill.

## SECTION 3 MAINTENANCE

This section lists the maintenance procedures that need to be performed.

*The Short Interval Maintenance Schedule* lists procedures that need to be performed every 4, 8 or 24 hours. *The Maintenance Log* lists procedures that need to be performed every 50, 100, 200, or 1000 hours. Keep track of machine maintenance by filling in the machine hours and the date you perform each procedure.



**This symbol** identifies the interval (hours of operation) at which each maintenance procedure should be performed.

Be sure to refer to option and engine manuals for other maintenance procedures.

### 3.1 Wear Life

**See Figure 3-1.** This chart lists estimated life expectancy of common replacement parts if proper maintenance and operation procedures are followed. Due to the many variables which exist during sawmill operation, actual part life may vary significantly. This information is provided so that you may plan ahead in ordering replacement parts.

Part Description	Estimated Life
B57 Blade Wheel Belts	500 hours
Up/Down Motor	2000 hours
Hydraulic Pump Solenoid	750 hours
Drum Switch, Up/Down Motor	1000 hours
Blade Guide Rollers	1000 hours
Power Feed Drum Switch	1200 hours
Drive Belt	1250 hours
Power Feed Motor	1500 hours
Power Feed Belt	2000 hours
Up/Down Belt	2000 hours

TABLE 0-0

### 3.2 Blade Guides

1. Check the rollers for performance and wear every blade change. Make sure the rollers are clean and spinning freely. If not, rebuild them. Replace any rollers which have worn smooth or have become cone shaped. See The LT20 Parts manual for blade guide rebuild kits and complete roller assemblies.

See Figure 3-1.

2. Make sure the blade screw in the top center of the C-frame is 1/16" (1.5 mm) below the bottom of the blade. If not, loosen the nut and adjust the screw as necessary. Failing to maintain this adjustment will lead to early blade breakage.

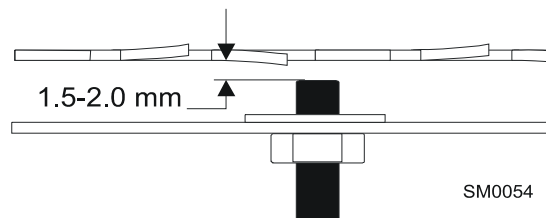

FIG. 3-1

### 3.3 Sawdust Removal

1. Remove the excess sawdust from the blade wheel housing and sawdust chute every blade change.

### 3.4 Carriage Track, Wiper & Scrapers

See Figure 3-2.

- 8 1. Clean the upper and lower track rails to remove any sawdust and sap buildup every eight hours of operation. Lubricate the lower track rail by wiping it with Dexron III ATF.
- 8 2. Remove sawdust from the upper cam housings. Loosen the thumb screws on the upper cam housing covers and open. Brush any sawdust buildup from the housings.
3. Check the track scrapers as needed. Make sure the scrapers fit firmly against the rail. If a track scraper needs to be adjusted, loosen the thumb screw, push the scraper downward until it fits firmly against the rail, and retighten the thumb screw.

25 Clean and lubricate the upper track wiper every twenty-five hours of operation. Unbolt the wiper, remove it from the sawmill, and remove any sawdust buildup. Soak the felt wiper with Dexron III transmission fluid, 10W30 motor oil or 3-in-1 turbine oil.



**CAUTION!** Reinstall the track wiper so that it lightly touches the track rail. If the wiper presses too firmly against the rail, it can cause the power feed to bind.

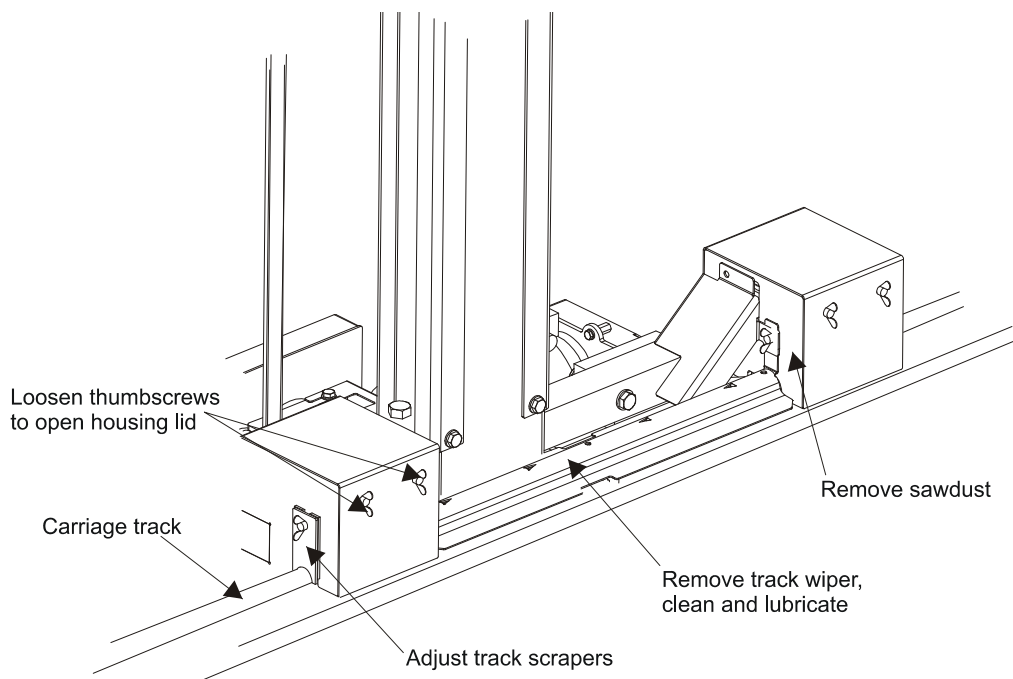

FIG. 3-2

### 3.5 Vertical Mast Rails

Lubricate the vertical mast rails with WD40, clean and wipe them dry every 50 hours of operation.



**CAUTION!** Never use grease on the mast rails as it will collect sawdust.

### 3.6 Miscellaneous

1. Apply a thin film of a lithium grease to the blade guide arm to help prevent it from rusting.



2. Lubricate the log turner (if equipped) with a lithium grease every fifty hours of operation. Lubricate the turner pivot points (e.g. with WD-40).



3. Grease the clamp mechanism, loading arm, and side supports with a NLGI No. 2 grade lithium grease every fifty hours of operation.



4. Oil all chains with an easily penetrating oil such as WD-40.



**CAUTION!** Do not use chain lube. It causes sawdust buildup in chain links.

5. Lubricate the board return pivot every fifty hours of operation with a NLGI No. 2 grade lithium grease. Apply grease to the grease fitting on the board return pivot tube.



6. Check the mill alignment every setup. See Section 5, Alignment.

7. Make sure all safety warning decals are readable. Remove sawdust and dirt. Replace any damaged or unreadable decals immediately. Order decals from your Customer Service Representative.



### 3.7 Blade Tensioner

1. Grease the tensioner handle screw with a lithium grease every fifty hours of operation, but at least once a week.

See Figure 3-3.

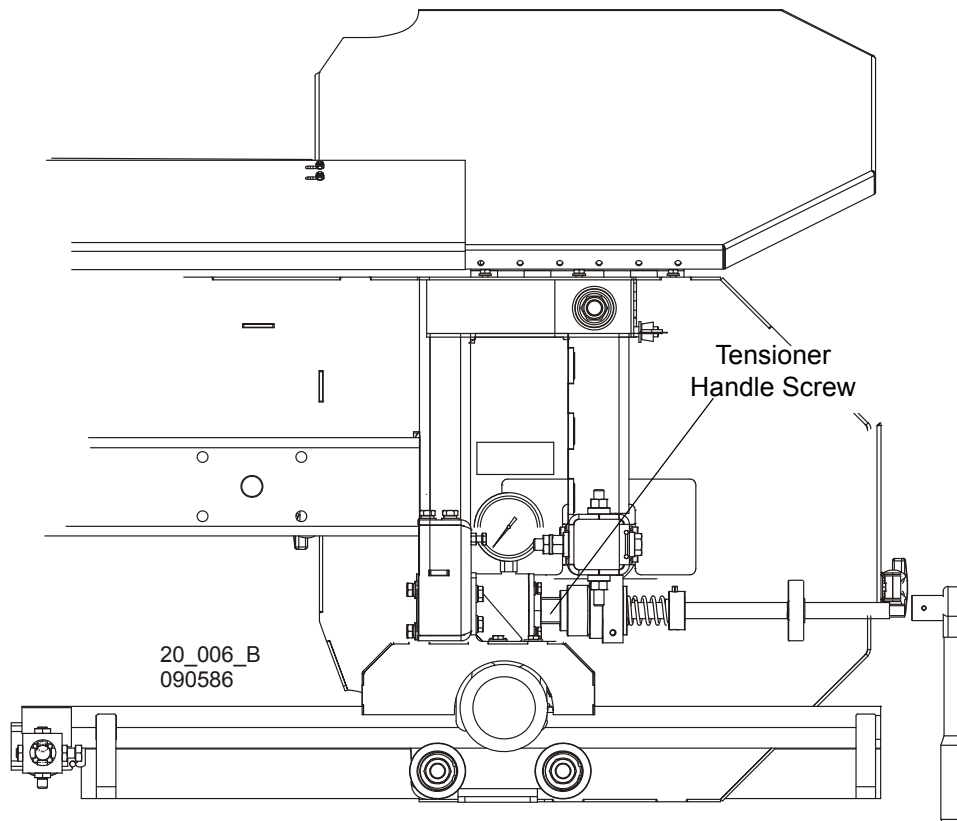



FIG. 3-3

### 3.8 Blade Wheel Belts

1. Check the blade wheel belts for wear every 50 hours of operation. Replace as needed.
2. Periodically check all belts for wear. Replace any damaged or worn belts as needed.

### 3.9 Drive Belt Adjustment

 **WARNING!** Do not for any reason adjust the drive belts with the motor running. Doing so may result in serious injury.

 See **Figure 3-2**. Check the drive belt tension after the first 20 hours, and every 50 hours thereafter. See the table below for drive belt tension specifications for your sawmill.

Motor/Engine	Belt Tension
E11, G13	7/16" (11mm) deflection with 8 lbs. (3.6 KG) of deflection force
E15, G15, D17, D22	7/16" (11mm) deflection with 16 lbs. (7,2 KG) of deflection force (double belt)

TABLE 0-0

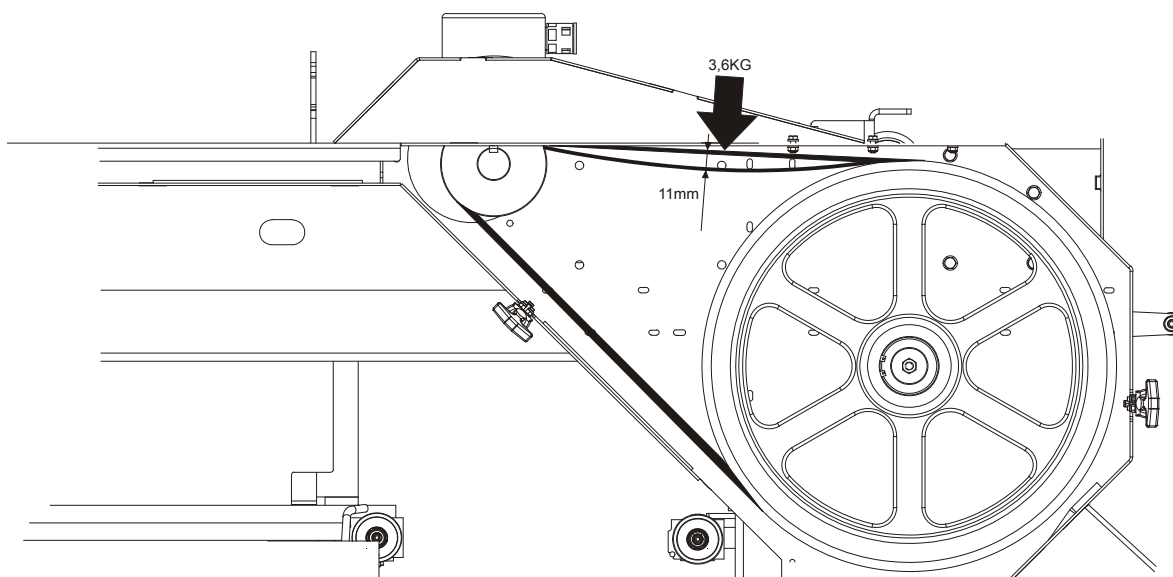

FIG. 3-4

To adjust the drive belt tension:

1. Raise the blade housing cover.

#### AC Sawmills

2. Loosen the four mounting bolts.
3. Loosen one of the adjustment nuts and using the other one adjust the drive belt(s) tension according to the specifications given in Table 3-2.

4. **Gas/Diesel Engines Only:** Tighten the four mounting bolts.

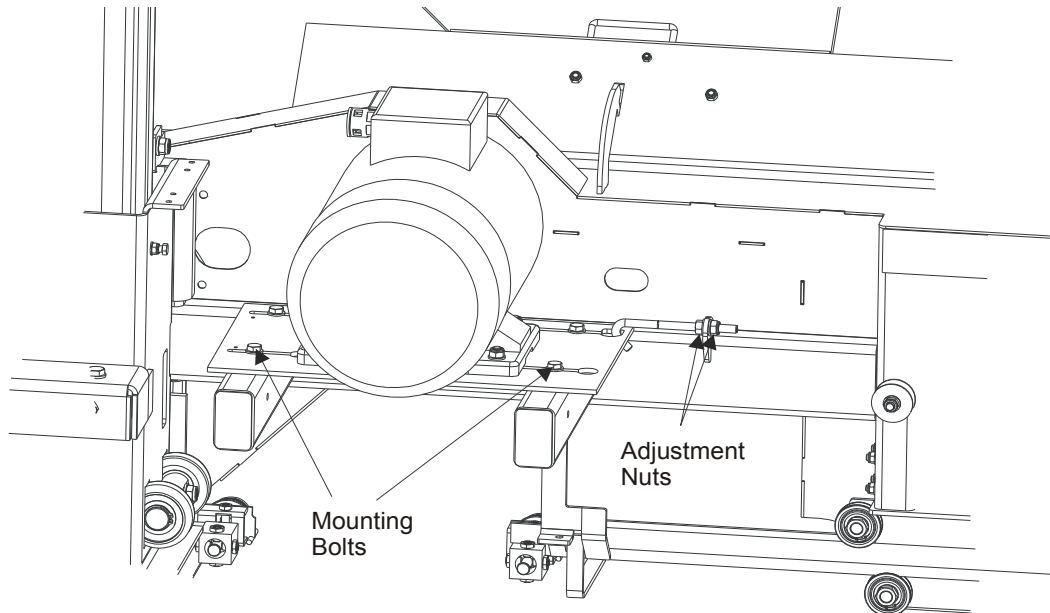
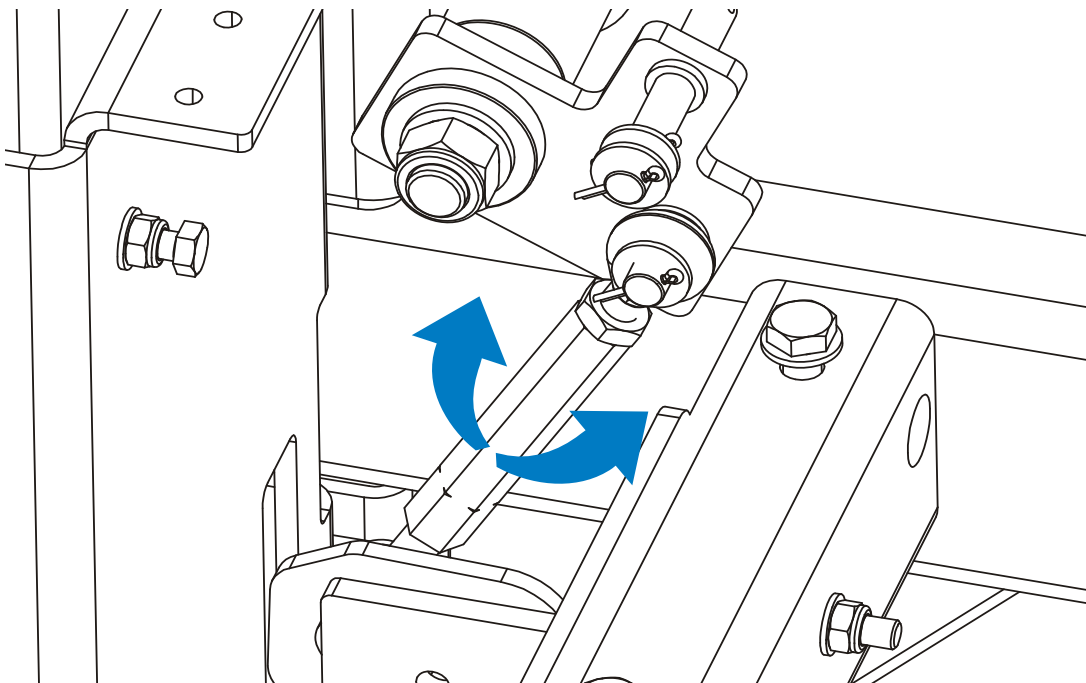

FIG. 3-5

**DC Sawmills**



To tighten - turn the bolt clockwise, and to loosen - turn it counter-clockwise.



Periodically check the belts for wear. Replace if the belt is damaged or worn.

### 3.10 Hydraulic System

1. Check the hydraulic fluid level every 50 hours of operation. Add fluid as necessary. The level in the hydraulic pump should be 3/4" (19mm) from the top with all cylinders collapsed.

If humidity is a problem or the mill is used outside in humid weather, drain and replace two quarts (.95 liters) of fluid every six months. This will drain any accumulated water and help prevent pump failure due to water ingestion. It also will prevent excessive fluid wear and allow the fluid to maintain its hot end performance. If humidity is not a problem, drain and replace one gallon (3.8 liters) of fluid every year to prevent fluid wear.

**See Figure 3-6.** If you are operating in temperatures -20° to 100° F (-29° to 38° C), use an all-weather hydraulic fluid such as Exxon Unavis J26. For alternate fluids and/or other temperature ranges, refer to the chart below. Operating above the recommended temperature range of a fluid could result in excessive pump wear. Operating below the recommended temperature range could result in reduced hydraulic cylinder speed. To change fluid types, replace one gallon of the current fluid with four liters of the alternate fluid.

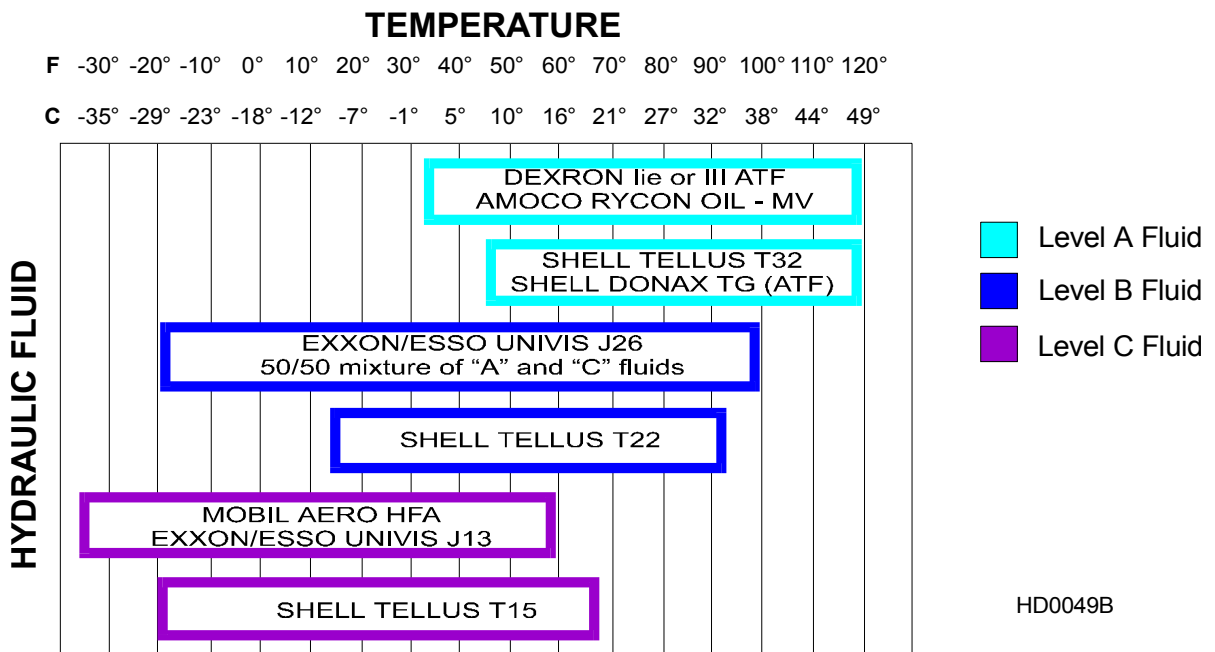

**FIG. 3-6**

2. Replace the hydraulic system cartridge filter every 500 hours of operation.
3. Periodically check all hydraulic lines and fitting as needed. Replace as necessary.

### 3.11 Up/Down System

1. Adjust the up/down chain tension as needed. Measure chain tension with the cutting head all the way to the top of the vertical mast. Secure the carriage with a chain at the top, or shim it underneath. Using the adjustment nut shown in Figure 3-7, adjust the chain tension so that there is 1" (2.5 cm) deflection in the center of the chain with a 5 lbs. (2.3 KG) deflection force.

 **WARNING!** Always secure the cutting head with a chain or a brace before adjusting or inspecting the up/down system. The cutting head may fall, causing severe injury or death.

See Figure 3-7. Use the adjustment nut shown below to tension the chain.

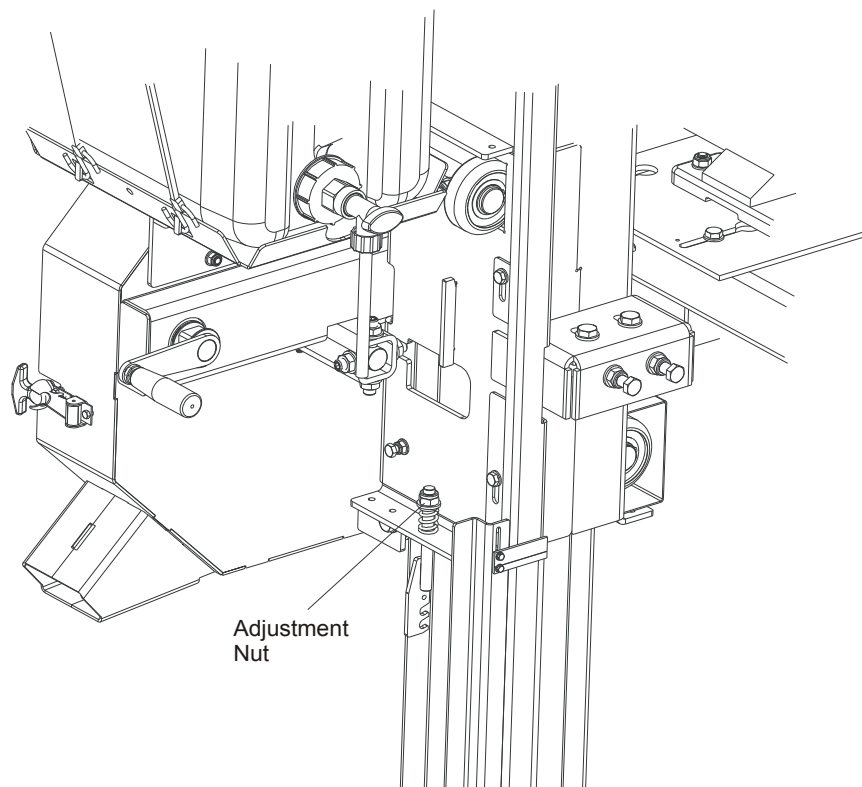

FIG. 3-7

500

Every 500 hours of operation, check the upper up/down sprocket and chain for wear or mis-alignment.

See Figure 3-8. Upper up/down sprocket alignment. The vertical axis of the sprocket must be perpendicular to the mast and the sprocket must be located in the centre of its bracket.

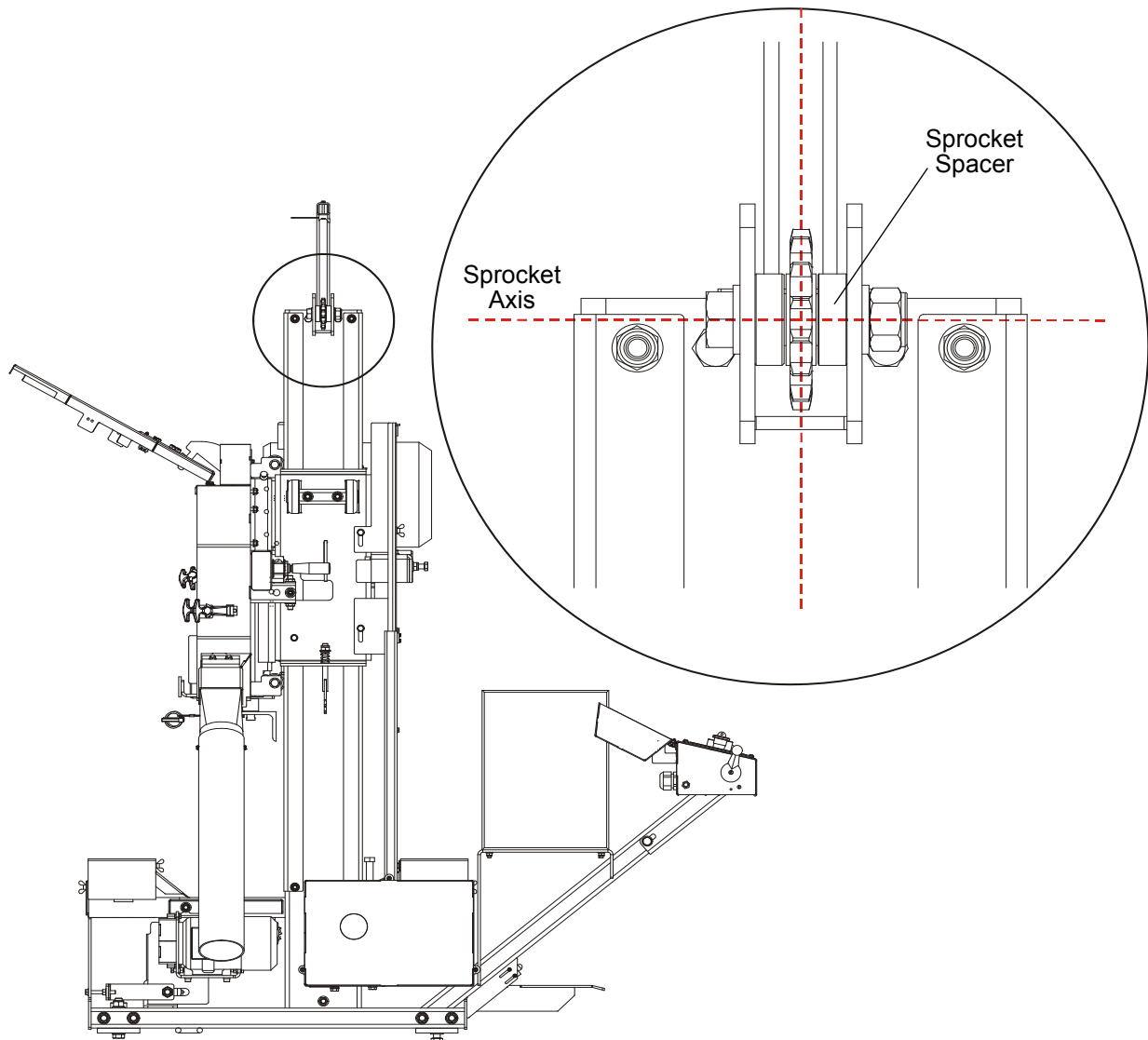

FIG 3-9.



**WARNING!** If you noticed the upper up/down system sprocket mis-alignment or wear of the up/down system chain, sprocket or sprocket bracket immediately stop the work and contact Wood-Mizer Customer Service. Failure to do so will result in serious injury or death.

2. Adjust the up/down gear belt tension as needed (option).



**WARNING!** Before adjusting, always remove the key from the key switch. Failure to do so may result in serious injury.

3. Loosen the four adjustment bolts shown below. Adjust the belt tension and tighten

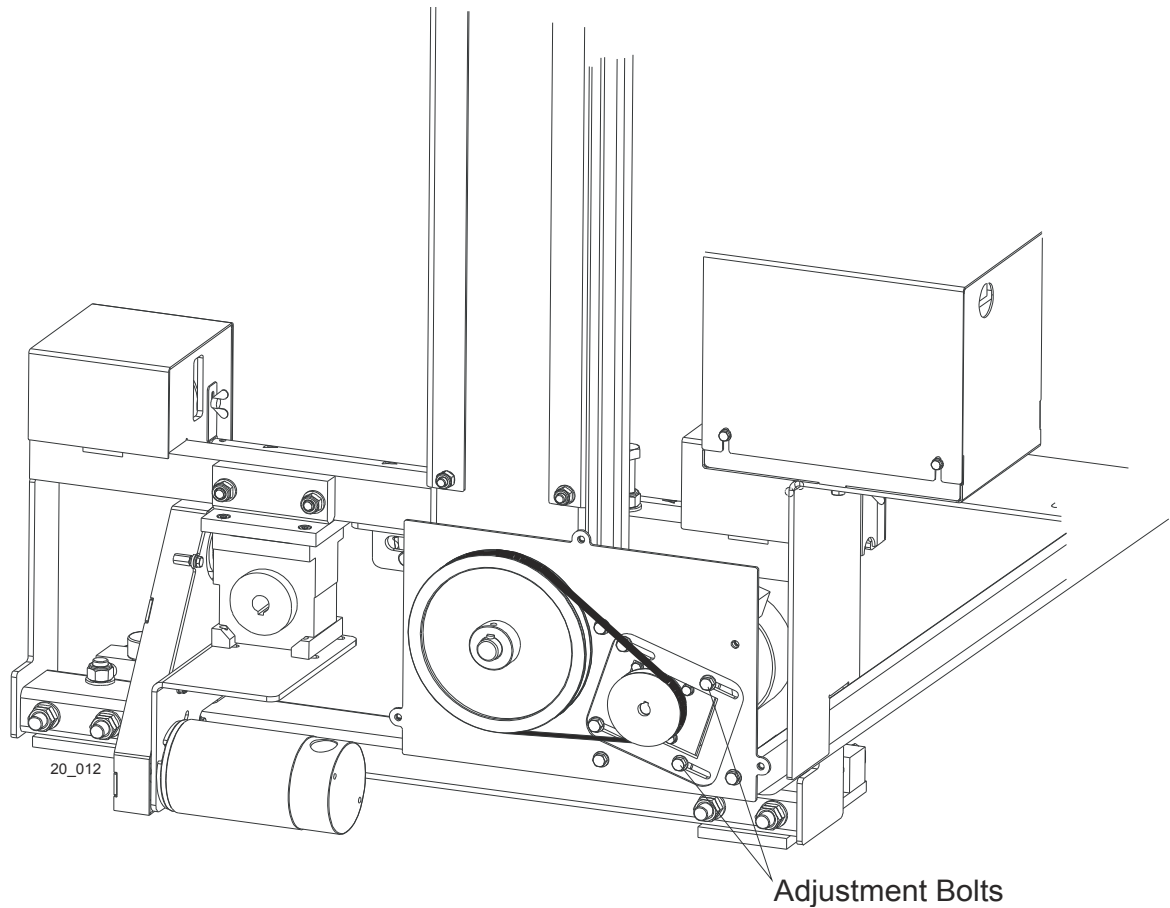

**FIG. 3-10**

the adjustment bolts.

### 3.12 Power Feed System

1. Adjust the power feed chain as needed.



**WARNING!** Always remove the key from the key switch before adjusting the chain. Failure to do so may result in serious injury.

See Figure 3-11. Loosen the sprocket nut. To tighten the chain, move the sprocket to the

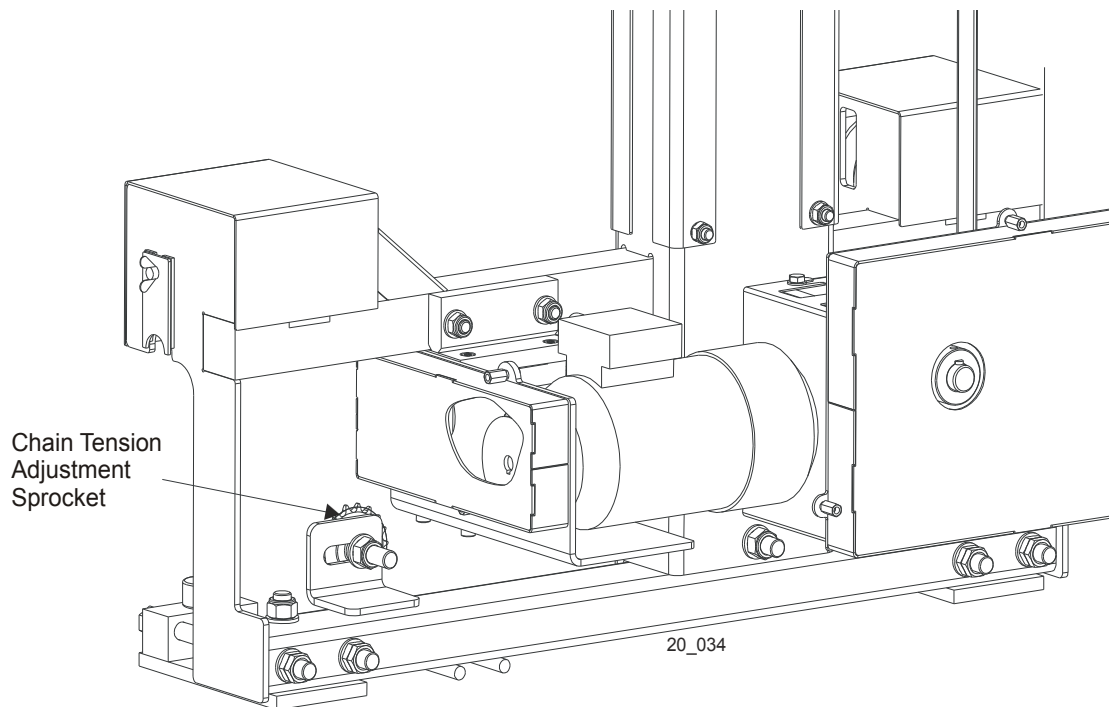

**FIG. 3-11**

left. To loosen the chain, move the sprocket to the right (towards the front end of the mill).



2. If necessary, align the power feed motor pulley with the gear reducer pulley.



**UWAGA! WARNING!** Remove the key from the key switch before adjusting the pulleys. Failure to do so may result in serious injury.

See Figure 3-12. Keep the pulleys aligned to avoid premature V-belt and pulleys wear. To

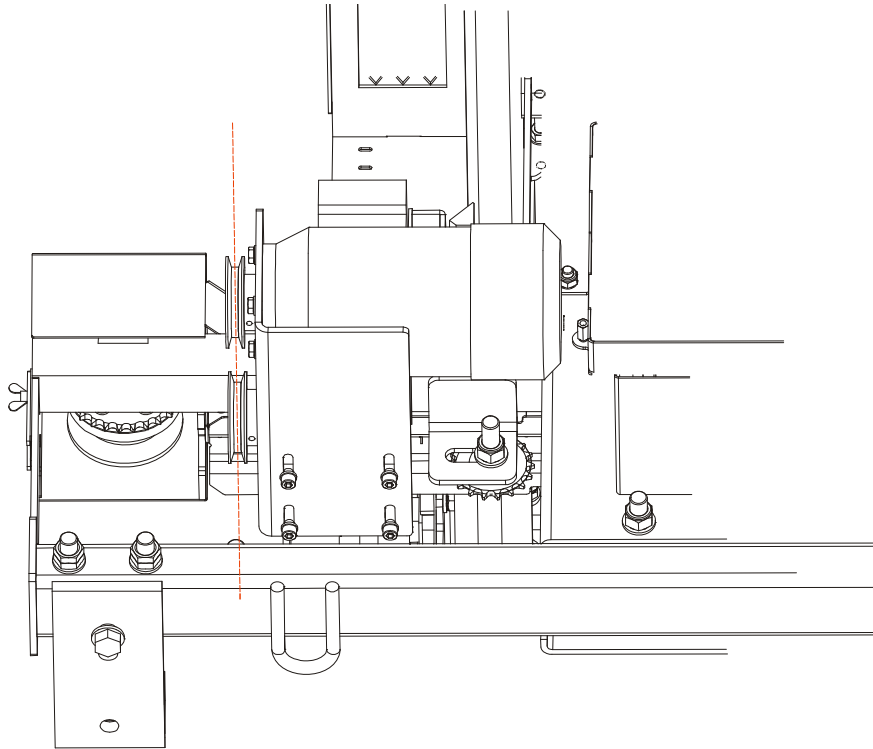

FIG. 3-12

align the pulleys, slide one of them on the shaft appropriately.

## SECTION 4 TROUBLESHOOTING GUIDE

### 4.1 Sawing Problems

<b>PROBLEM</b>	<b>CAUSE</b>	<b>SOLUTION</b>
<b>Blades Dull Quickly</b>	Dirty logs	Clean or debark logs, especially on entry side of the cut
	When grinding teeth, heating too much and causing teeth to soften	Grind just enough metal to restore sharpness to the teeth. Use water/coolant while sharpening blade
	Poor sharpening techniques	Make sure the tip is being sharpened completely (See Sharpener Manual)
<b>Blades Break Prematurely</b>	Rubber belts on blade wheels worn to a point that blade contacts metal pulley - look for shiny spots on edge of wheels	Change blade wheel belts (B-57)
	Poor sharpening techniques	See Sharpener Manual
	Tension too tight	Tension blade to recommended specifications
<b>Blade Does Not Track Right on Drive Wheel</b>	Cant adjustment is incorrect	Readjust
	Flat/worn belts	Replace B-57 belts
<b>Blade Guides Do Not Spin While Cutting</b>	Frozen bearings	Replace bearings
	Stiff bearings	Grease bearings
<b>Blade Does Not Stop Immediately After Disengaging</b>	Brake strap too loose	Adjust brake strap
<b>Drive Belts Come Off Pulleys When Disengaging Blade</b>	Brake strap too loose	Adjust brake strap
	Brake drum misaligned	Realign on drive shaft
	Brake strap tightened with one edge too loose and one edge too tight	Adjust brake strap
<b>Drive Belts Wear Prematurely or Jump</b>	Engine/motor and drive pulleys out of alignment	Align pulleys <a href="#">See Section 4.5 Engine/Motor and Drive Pulleys Alignment.</a>

<b>PROBLEM</b>	<b>CAUSE</b>	<b>SOLUTION</b>
<b>Boards Thick Or Thin On Ends Or Middle Of Board.</b>	Stress in log which causes log to not lay flat on the bed.	After log has been squared, take equal cuts off opposing sides. Take a board off the top. Turn the log 180 degrees. Make a cut. Repeat, keeping the heart in the middle of the cant, and making it your last cut.
	Set in teeth.	Resharpen and reset blade.
<b>Height Adjustment Jumps or Stutters When Moving Up or Down.</b>	Bed rails misaligned.	Realign sawmill.
	Mast needs lubrication.	Lubricate mast track surface.
	Up/down chain improperly adjusted.	Adjust up/down chain.
<b>Lumber Is Not Square</b>	Vertical wear pads are too tight.	Adjust pads.
	Drive belt(s) loose.	Adjust belts.
	Vertical side supports not square to bed	Adjust side supports.
<b>Sawdust Builds Up On Track</b>	Blade not parallel to bed rails	Adjust bed rails parallel to blade.
	Sawdust or bark between cant and bed rails	Remove particles
	Tooth set problems	Resharpen and reset blade
<b>Wavy Cuts</b>	Excessive oiling	Do not oil track
	Track wipers worn	Adjust wipers to firmly contact track
<b>Wavy Cuts</b>	Track is sticky	Clean track with solvent and apply silicone spray
	Excessive feed	Slow feed rate
	Improperly sharpened blade (This will be the problem 99% of the time!)	Resharpen blade (See Sharpener Manual - read entire manual!)
<b>Wavy Cuts</b>	Blade guides improperly adjusted	Adjust blade guides.
	Sap buildup on blade	Use Water Lube.
	Tooth set problem	Resharpen and reset blade

## 4.2 Electrical Problems

<b>PROBLEM</b>	<b>CAUSE</b>	<b>SOLUTION</b>
<b>Up/down Excessively Slow.</b>	Vertical wear pads too tight.	Adjust pads.
	Up/down belt loose.	Adjust belt to be as loose as possible without slipping
<b>Up/down Or Power Feed Motors Do Not Work.</b>	Worn/dirty contacts in drum switch.	Replace switch or remove control panel cover and clean contacts.
	Bad key switch.	Replace key switch.
	Burned-out motor.	Replace motor.
<b>Up/Down Or Power Feed Switches Remain Engaged When Switch Is Released.</b>	Worn or dirty contacts in drum switch.	Manually move the power feed or up/down switch back to neutral or "off" position. Replace drum switch or remove control panel cover and clean and lubricate contacts NOTE: Use only contact grease supplied by Wood-Mizer.
	Drum switch spring broken.	Manually move the power feed or up/down switch back to neutral or "off" position. Replace drum switch spring.
<b>Up/Down Or Power Feed Motors Overheat And Loose Power.</b>	System overload or bind occurred.	Correct problem. <a href="#">See Section 4.3 Power Feed Problems</a> . Allow motor to cool before restarting.
	Normal operation factors exceeded (eg: up/down control jockeyed excessively).	Allow motor to cool before restarting.
<b>Everything Works And Then Cuts Out - Works Again.</b>	Bad fuse, or ground connection.	Check and tighten connections.
<b>Nothing Works Electrically.</b>	Blown fuse.	Replace.

### 4.3 Power Feed Problems

<b>PROBLEM</b>	<b>CAUSE</b>	<b>SOLUTION</b>
<b>Power Feed Is Jerky At Low Speeds Or Does Not Move Until Speed Is Above Halfway Mark.</b>	Drum switch is dirty.	Clean drum switch and lubricate with contact grease supplied by Wood-Mizer.
	Drum switch contacts are bad	Check that contacts are in good condition and positively close circuit.
	Components are loose or wires are broken.	Check the control panel. Repair the control panel.
	Speed switch is worn.	Replace the speed switch.
<b>Power Feed Is Jerky, But Power Feed Motor Runs Properly At All Speeds.</b>	Speed switch is blocked.	Turn off the power for 20 seconds and turn it back on.
	Problem is mechanical.	Refer to the Mechanical Test.

## 4 Troubleshooting Guide

### Power Feed Problems

<b>PROBLEM</b>	<b>CAUSE</b>	<b>SOLUTION</b>
<b>Power Feed Motor Overheats.</b>	Middle track oiler is dragging.	Clean middle track oiler and lubricate with 30-weight oil or ATF (Automatic Transmission Fluid) such as Dexron II. Allow motor to cool before restarting.
	Ground is not level.	Level mill with carpenter's level. Allow motor to cool before restarting.
	Track roller bearing drag is excessive.	Lubricate bearings; Replace tight bearings. Allow motor to cool before restarting.
	Lower track rollers are not aligned properly.	Check stop block clearance from lower bed rail. Allow motor to cool before restarting.
	Chain is dragging.	Make sure chain is centered on cam follower bearing; Clean and lubricate chain; Adjust chain tension. Allow motor to cool before restarting.
	Chain is improperly tensioned.	Adjust chain tension. Allow motor to cool before restarting.
	Seat load is excessive.	Check seat bearings for freedom of movement; Loosen clamping screw 1/4 turn. Allow motor to cool before restarting.
	Power feed is binding.	Adjust belt tension; Check condition of belt, pulleys, bearings, and sprocket; Check motor for ground fault. Allow motor to cool before restarting.
	Saw head load is excessive.	Avoid unnecessary modifications to saw heads that would give them extra weight. Allow motor to cool before restarting.
	Blade is dull or improperly set.	Use proper blade maintenance procedures (See Sharpener or Toothsetter manual). Allow motor to cool before restarting.

## 4.4 Hydraulic Problems

PROBLEM	CAUSE	SOLUTION
You Can Actuate Any Hydraulic Handle, But Get No Response From The Pump.	Carriage not positioned properly to provide power to the pump	Make sure carriage contact bracket is adjusted far enough forward for battery positive contact to touch 6ft. strip on main tube. Check contact and strip for tarnish or loose wires. Clean as necessary
	Hydraulic feeder does not work	<p>Turn on the power switch on the front side of the electric box mounted on the front side of the hydraulic box. Check whether the power is on (in position "1")</p> <p>Check whether the key switch is in ACC position</p> <p>Disconnect the plug on the left side of the electric box and change the phases using a screwdriver</p> <p>Check whether the emergency switch is off</p>
	One phase lacks power	Check fuses in the electric connector
	Pump motor relay damaged	Have a qualified electrician change it
	Hydraulic pump motor is overheated	Let the motor cool. When the motor is off, reset the thermal motor breaker located in the electric box mounted in the hydraulic box
	The hydraulic feeder works despite the release of the hydraulic control lever	<b>Standard situation.</b> Hydraulic feeder assembly should keep working for 5-8 seconds after the hydraulic lever is released (in the neutral position)
	Poor ground connection	Check ground connection between pump and saw frame. Check contact and rail for tarnish or loose wires. Clean as necessary
You Can Get Response From the Pump By Actuating All But One or Two Handles	Valve assembly switch contacts are not properly adjusted	<p>Locate the valve switch at the bottom of the valve assembly. Use a 3MM allen wrench to loosen the set screw on each of the five switch contacts. Press each contact to the valve block and tighten the contact set screw to secure in place. <b>CAUTION!</b> Do not overtighten!</p> <p><b>NOTE:</b> Do not adjust the valve switch or switch spring; they have been preset at the factory.</p>

## 4

## Troubleshooting Guide

## Hydraulic Problems

<b>PROBLEM</b>	<b>CAUSE</b>	<b>SOLUTION</b>
<b>Pump Motor Runs With Little Or No Response From The Cylinders</b>	Low fluid level	Check fluid level. Add an all-season hydraulic fluid such as Amoco Rycon Oil MV or Mobil Multipurpose ATF (automatic transmission fluid) until level is 4 - 4 1/2" from bottom of reservoir with all cylinders retracted
	Pressure relief valve moved from proper setting	Adjust pressure relief valve.
	Low air temperature causing fluid to thicken	Allow fluid to warm up. Synthetic fluids are available that allow for hydraulic operation in cold weather conditions (Mobil SHC 526)
<b>Pump Motor Runs Continuously When Power Contact Is Made</b>	Closed contacts of the pump motor relay	Tapping the solenoid may solve this problem temporarily. Replace the solenoid.
<b>Fluid Leaks From Around Cylinder Piston Ram</b>	Worn seals	Replace seals in cylinder. Check piston ram for abrasive weld that may be causing premature seal failure
<b>Fluid Leak Around Pump Box</b>	Loose seal or fitting	Wipe pump off completely to locate cause of leak. You may have to unbolt the pump to wipe behind it. <b>NOTE:</b> Movement of the sawmill can cause fluid to slosh up into the foam filter in the reservoir cap, and subsequently spray out, giving the appearance that fluid is leaking from the pump



<b>PROBLEM</b>	<b>CAUSE</b>	<b>SOLUTION</b>
<b>Hydraulic Side Supports Go Down Before Or At Same Time As Log Turner</b>	Dirt in sequence valve	Remove sequence valves and clean thoroughly with kerosene. <b>NOTE:</b> Be sure to reassemble the valve and install it in its original position on the cylinder
	Retainer in sequence valve worn	Replace sequence valve
	Low air temperature causing fluid to thicken	Allow fluid to warm up. Synthetic fluids are available that allow for hydraulic operation in cold weather conditions (Mobil SHC 526)
<b>Hydraulic Turner Goes Up Before Or At Same Time As Side Supports</b>	Spring weakening in sequence valve	Locate sequence valve at top of turner cylinder. Turn heavy spring in about 1/4 turn
	Dirt in sequence valve	Remove sequence valves and clean thoroughly with kerosene. <b>NOTE:</b> Be sure to reassemble the valve and install it in its original position on the cylinder
	Retainer in sequence valve worn	Replace sequence valve
	Low air temperature causing fluid to thicken	Allow fluid to warm up. Synthetic fluids are available that allow for hydraulic operation in cold weather conditions. (Mobil SHC 526)
	Springs weakening in sequence valve.	Locate sequence valve at bottom of turner cylinder. Turn heavy spring in about 1/4 turn

## 4.5 Engine/Motor and Drive Pulleys Alignment

1. Install the drive belt.
2. Use a straight edge to align the engine/motor pulley to the drive pulley.
3. Check front-to-back movement of the engine does not exceed 1/4". Tighten the motor mount U-bolts if necessary.
4. Engage the clutch handle and adjust the drive belt tension to 7/16" deflection with 10 lb. of force.
5. Recheck the pulley alignment and engine squareness with the clutch handle engaged. Adjust if necessary.
6. Adjust the drive belt support to 8,0 mm from the belt while engaged.

## 4.6 Hydraulic Pressure Test



**CAUTION!** Pressure should not exceed 2000 psi. Pressure above 2000 p.s.i. may also damage the hydraulic hoses.

## SECTION 5 SAWMILL ALIGNMENT

### 5.1 Pre-Alignment Procedures

The Wood-Mizer sawmill is factory aligned. This section includes instructions on how to realign the sawmill completely. Be scrupulous when performing all alignment steps as sawmill alignment determines the accuracy of your cuts. The alignment procedure should be performed approximately every 1500 hours of operation (sooner if you regularly transport the sawmill over rough terrain).

#### **Routine Alignment Procedure:**

1. Install and track the blade ([See Section 5.3](#)).
2. Check the angle of the blade in relation to the bed rails and adjust the lower track rollers if necessary ([See Section 5.18](#)).
3. Check and adjust the vertical alignment of the blade guide arm ([See Section 5.7](#)).
4. Check and adjust the horizontal alignment of the blade guide arm ([See Section 5.10](#)).
5. Check and adjust the vertical angle of the blade guides ([See Section 5.13](#)).
6. Check and adjust the horizontal angle of the blade guides ([See Section 5.15](#)).
7. Check and adjust the spacing between the blade guide flange and the back of the blade ([See Section 5.14](#)).
8. Check and adjust the horizontal angle of the side supports ([See Section 5.16](#)).
9. Check and adjust the vertical angle of the side supports ([See Section 5.17](#)).
10. Check that the blade height scale accurately displays the actual distance from the bottom of the blade to the bed rails and adjust if necessary ([See Section 5.19](#)).

#### **Complete Alignment Procedure:**

Perform all steps in this section to completely realign the sawmill.

## 5.2 Frame Setup

Stationary sawmills should be setup on firm, level ground before proceeding with alignment.

Portable sawmills should also be setup on firm, level ground.

: Adjust the two middle outriggers on the main frame tube down just enough to lift weight from the trailer tire.

: Adjust the two end outriggers on the main frame tube down just enough to lift weight from the trailer tire.

**All Portable Sawmills:** Adjust the two outer outriggers down just so they touch the ground but do not bear weight.

[See SECTION 2 SETUP & OPERATION](#), for additional setup information.

## 5.3 Blade Installation And Alignment

See **Figure 5-1**. Install a blade and apply the appropriate tension. Blade tension is adjusted with the tension handle shown below.

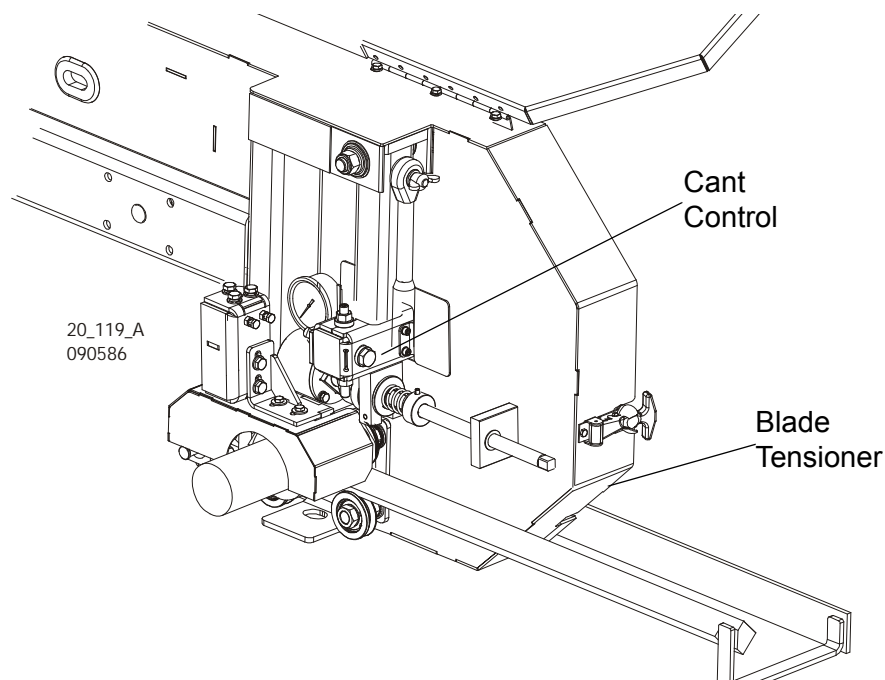

**FIG. 5-1**

**Electric Sawmills:**

1. Turn the key switch to the "H" position.



2. Open the blade housing cover.
3. Manually spin one of the blade wheels until the blade positions itself on the blade wheels.

**Gas Sawmills:**

1. Turn the key switch to the "0" position and remove the key.
2. Open the blade housing cover.
3. Release the locking pin. To do this, pull it outward and rotate.
4. Push the clutch lever up lightly so that the locking pin drops down into the hole. At this position of the lever the blade brake is released and the drive belt is loosened.

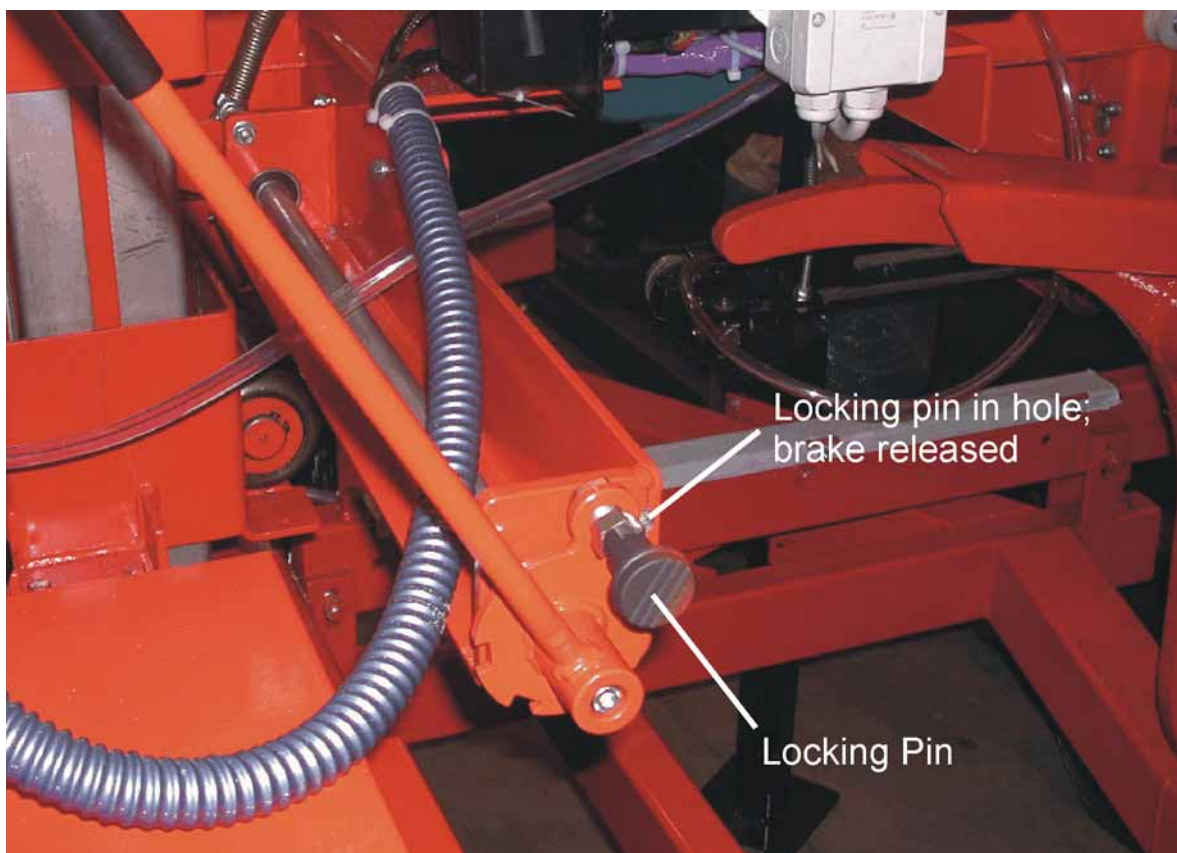
**FIG. 5-2**

5. Spin one of the blade wheels by hand until the blade positions itself on the blade wheels.

Check the vertical alignment of the idle-side blade wheel. The gullet of the blade should ride the same distance from the front edge of the wheel at the top and bottom of the wheel. If it does not, loosen and tighten the appropriate adjustment screws on the wheel shaft.

See **Figure 5-3**. The blade wheels should be adjusted so that the gullet of 1 1/4" blades rides 3.0 mm (0.12") out from the front edge of the wheels ( $\pm 1.0$  mm [0.04"]). The gullet of 1 1/2" blades should ride 4.5 mm (0.18") from the front edge of the wheels ( $\pm 1.0$  mm [0.04"]). Do not let the teeth ride on the belt.

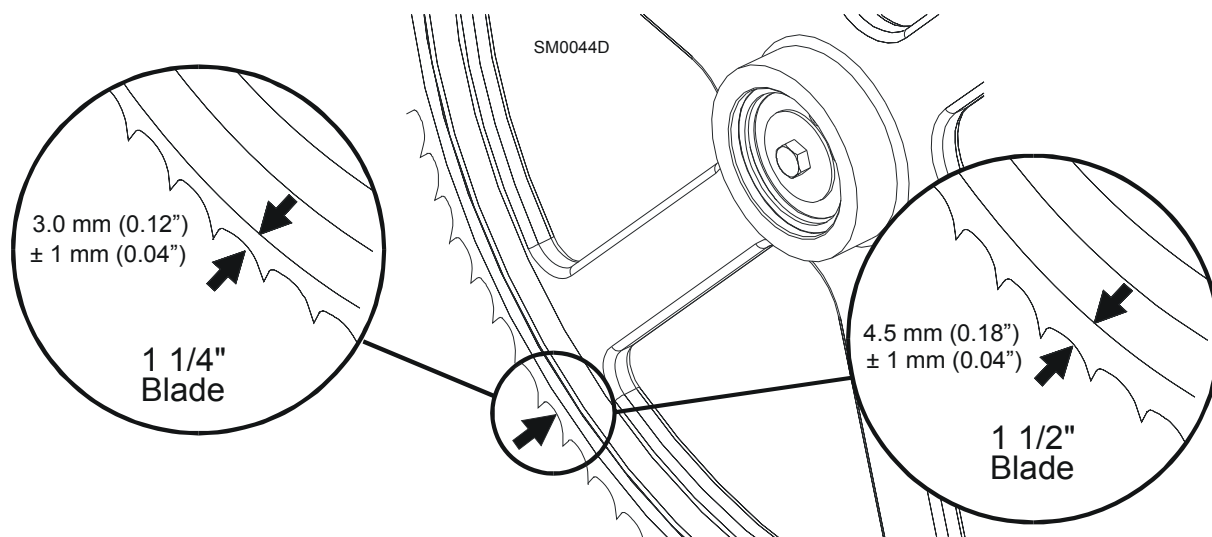

FIG. 5-3

To adjust where the blade travels on the idle-side blade wheel, use the cant control shown in **Figure 5-1**.

To move the blade out on the blade wheel, turn the cant adjustment screw clockwise. To move the blade in on the blade wheel, turn the screw counterclockwise.

Some adjustment in blade tension may be needed to compensate for adjustments made with the cant control.

Adjustment with the cant control is usually all that is required to track the blade properly on both blade wheels. The drive-side blade wheel will usually not have to be adjusted. If necessary, the drive-side wheel can be adjusted as follows:

Locate the nuts and the clamping screws located on the drive-side of the cutting head. If the blade is too far forward on the wheel, turn the screw located on the inside of the head counterclockwise and turn the screw located on the outside of the head clockwise. Make sure to tighten the nuts against the shaft housing when adjustment is complete.



## 5.4 Blade Wheel Alignment

The blade wheels should be adjusted so they are level in the vertical and horizontal planes. If the blade wheels are tilted up or down, the blade will want to travel in the tilted direction. If the blade wheels are tilted horizontally, the blade will not track properly on the wheels.

1. Use the blade guide alignment tool to check the vertical alignment of each blade wheel. Attach the tool to the blade near the inner blade guide mount. Be sure the tool does not rest on a tooth or burr, and is lying flat against the bottom of the blade.

See Figure 5-4.

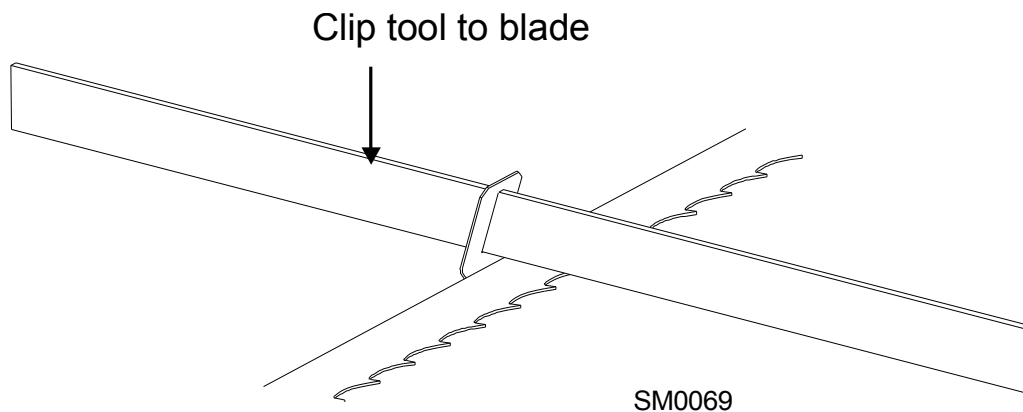

FIG. 5-4

2. Move the saw carriage so the front end of the tool is positioned over the first bed rail. Measure from the bottom of the tool to the top surface of the bed rail.
3. Move the saw carriage so the rear of the tool is positioned over the bed rail. Again, measure from the bottom of the tool to the bed rail.
4. If the two measurements differ by more than ( $\pm 1.0$  mm), adjust the vertical tilt of the drive-side blade wheel.

## 5 SAWMILL ALIGNMENT

### Blade Wheel Alignment

**See Figure 5-5.** Use the vertical adjustment screws to adjust the drive-side blade wheel. To tilt the wheel, loosen the top adjustment screw one quarter turn. Loosen the jam nut on the bottom adjustment screw and tighten the screw. Tighten the top and bottom jam nuts.

To tilt the wheel, loosen the bottom adjustment screw one quarter turn. Loosen the jam nut on the top adjustment screw and tighten the screw. Tighten the top and bottom jam nuts.

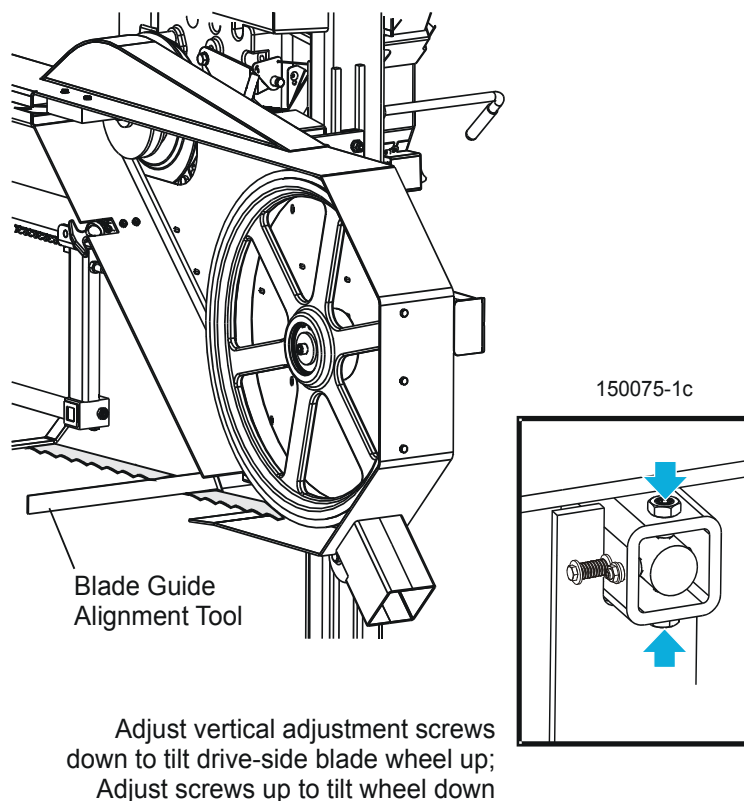
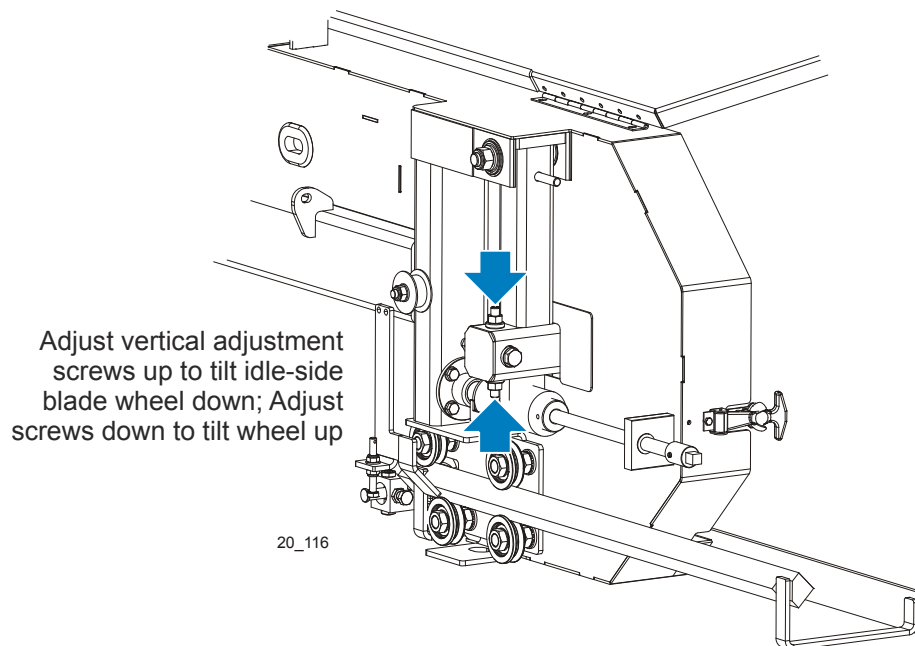

**FIG. 5-5**

5. Recheck the vertical tilt of the drive-side blade wheel with the blade guide alignment tool. Readjust the blade wheel as necessary until the front and rear of the tool are the same distance from the bed rail ( $\pm 1.5$  mm).
6. Remove the tool from the blade and reattach it near the outer blade guide assembly.
7. Measure from the tool to the bed rail at both ends of the tool. If the measurements at the front and rear ends of the tool differ by more than ( $\pm 1.5$  mm), adjust the vertical tilt of the idle-side blade wheel.

**See Figure 5-6.** Use the vertical adjustment screws to adjust the idle-side blade wheel. To tilt the wheel up, loosen the bottom adjustment screw one quarter turn. Loosen the jam nut on the top adjustment screw and tighten the screw. Tighten the top and bottom jam nuts.

To tilt the wheel down, loosen the top adjustment screw one quarter turn. Loosen the jam nut on the bottom adjustment screw and tighten the screw. Tighten the top and bottom jam nuts.

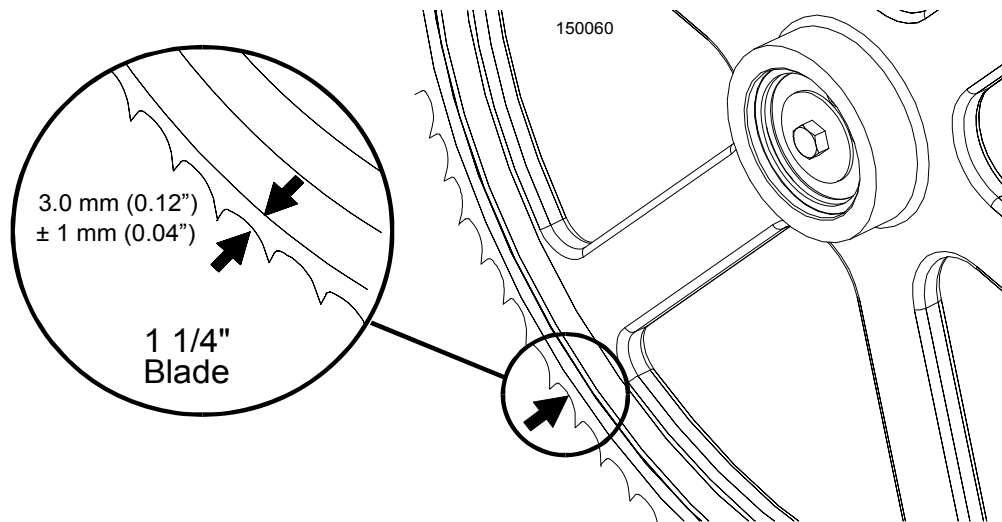

**FIG. 5-6**

8. Recheck the vertical tilt of the idle-side blade wheel with the blade guide alignment tool. Readjust the blade wheel as necessary until the front and rear of the tool are the same distance from the bed rail.

9. Check the position of the blade on the idle-side blade wheel.

See **Figure 5-7**. The horizontal tilt of the blade wheel should be adjusted so that the gullet of an 1-1/4" blade is 3.0 mm out from the front edge of the wheel ( $\pm 1.0$  mm).



**FIG. 5-7**

See **Figure 5-8**. Use the cant control adjustment to adjust the idle-side blade wheel. If the blade is too far forward on the wheel, turn the cant control counterclockwise. If it is too far back on the wheel, turn the cant control clockwise.

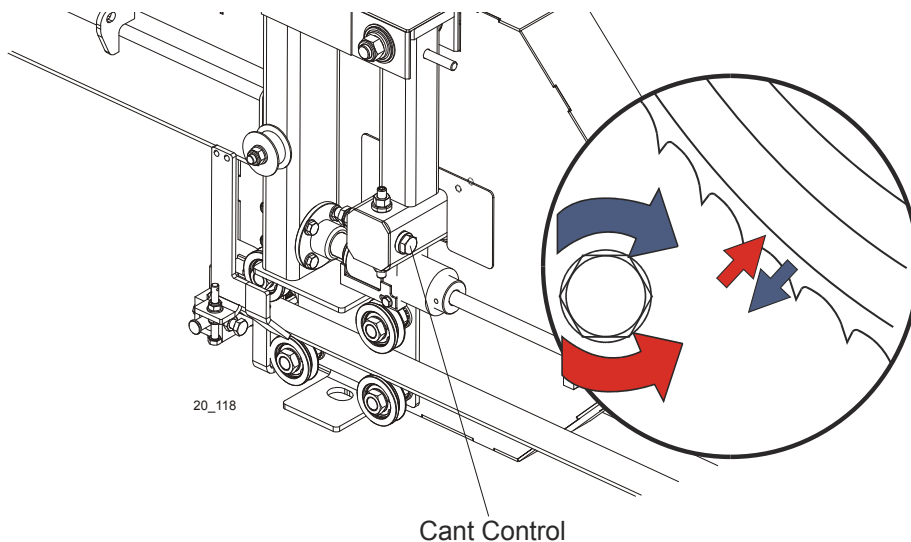

**FIG. 5-8**

10. Check the position of the blade on the drive-side blade wheel. The blade should be positioned on the wheel as described for the idle-side blade wheel. Adjust the drive-side blade wheel if necessary.

**See Figure 5-9.** Use the horizontal adjustment screw to adjust the drive-side blade wheel. Loosen the jam nut on the adjustment screw. Loosen adjustment screw to move blade out on wheel. Tighten adjustment screw to move blade in on wheel. Tighten the jam nut.

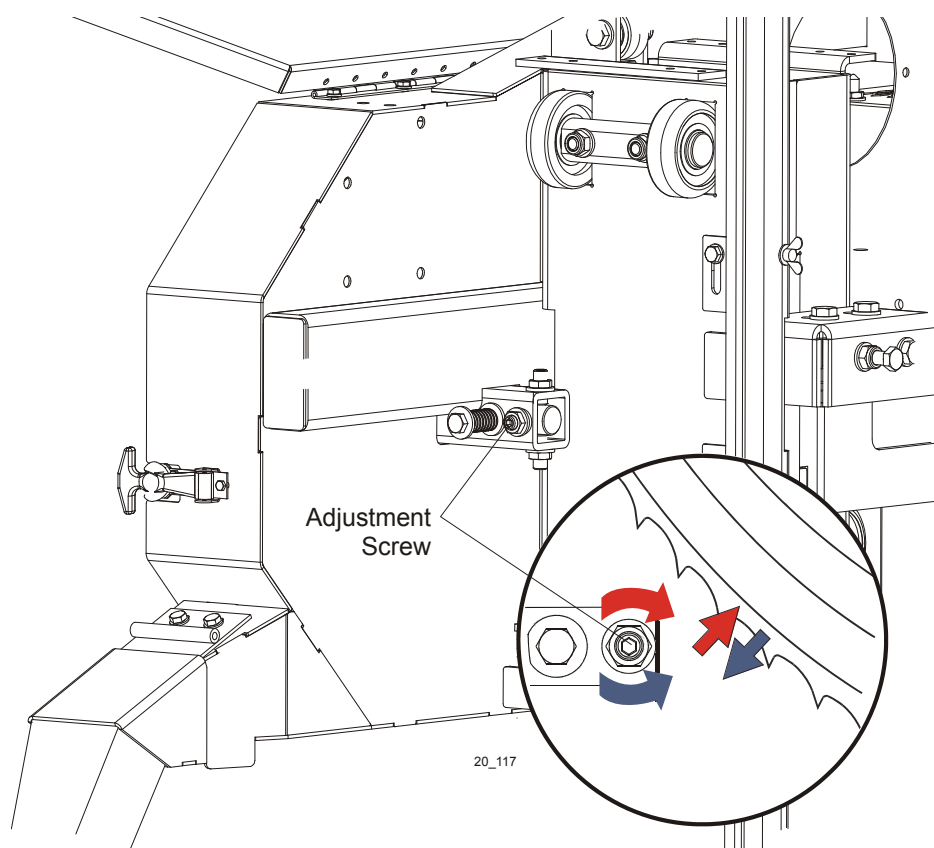
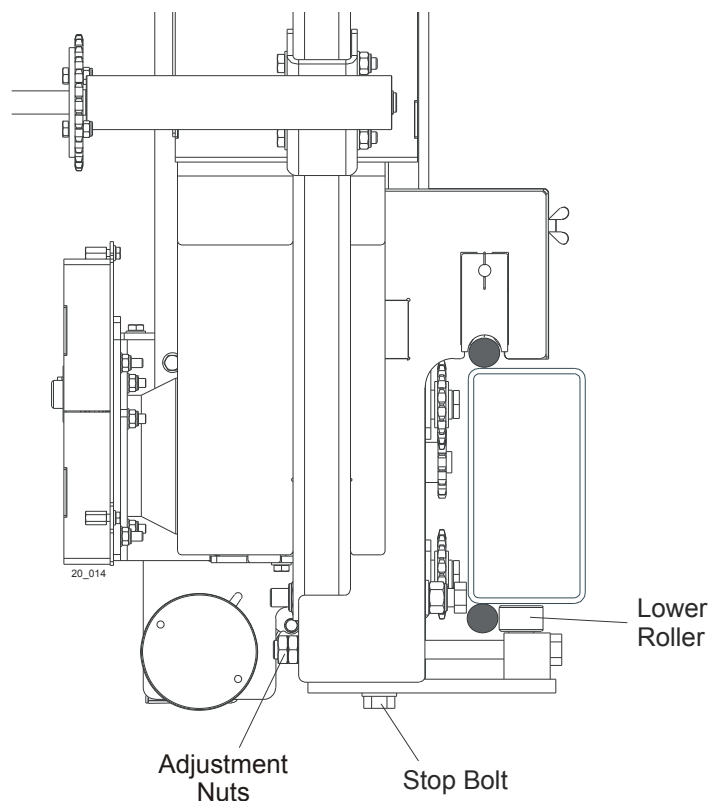

FIG. 5-9

## 5.5 Adjusting The Lower Track Rollers

See **Figure 5-10**. Making these adjustments correctly will give you square cuts and accurate dimensions across the width of your boards

1. Using the power feed switch, move the saw carriage so that the blade is positioned over the front pivot bed rail.
2. Check the lower rollers. Both rollers should touch the rail so that you cannot spin them by hand. If the rollers are not adjusted evenly and you can spin either one, loosen the stop bolt and adjust the adjustment nuts until the roller cannot be spun by hand. Check the other roller and adjust if necessary. Adjust both rollers until each evenly supports the carriage and you cannot spin either by hand.
3. Move the carriage forward until the blade is positioned over the rear pivot bed rail. Repeat the step #2 until the lower rollers are adjusted properly at the front and rear of the sawmill.



**FIG. 5-10**

4. Remove the blade guides, or adjust them so that they do not touch the blade.
5. Open the adjustable blade guide arm to within 1/2" (15 mm) of full open.
6. Move the carriage back to the front pivot bed rail. Raise the cutting head until the bottom

of the blade is 17" (400 mm) above the outside of the pivot rail support by actual measurement with a tape or ruler.

See Figure 5-11.

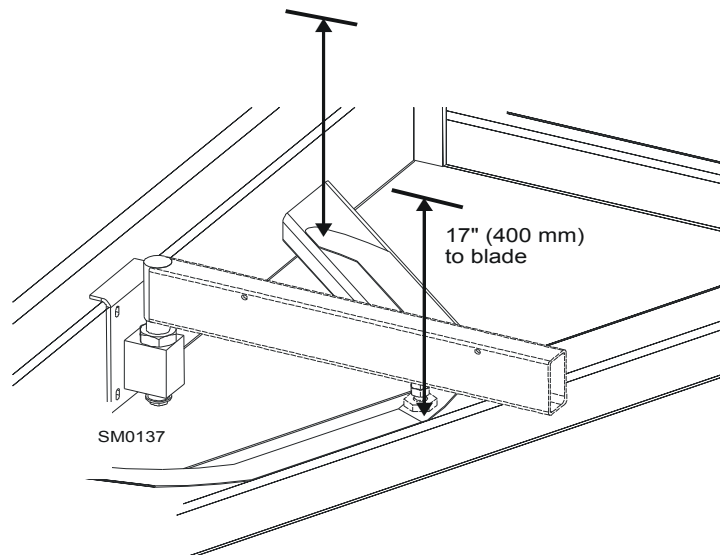

FIG. 5-11

7. Move the carriage forward to check the distance to the blade at the inside of the pivot rail support. Both measurements should be equal within ( $\pm 1.0$  mm [0.04"]).
8. Using the adjustment nuts adjust the lower rollers to tilt the cutting head until the blade is parallel ( $\pm 1.0$  mm [0.04"]) to the pivot rail support.

**NOTE:** Adjustments of the lower track rollers change the angle between the cutting head and sawmill bed rails. Only small adjustments of the lower track rollers should ever be needed.

9. After the lower track rollers are adjusted properly, adjust the stop screw. Tighten the screw until it touches the main bed tube. Then, back the screw off 1/2 turn. The distance from the rail should be 1.0 mm [0.04"].



**CAUTION!** It is important that the stop screw is properly adjusted to secure the carriage on the track rails. Failure to properly adjust the stop screw can cause cutting head damage, especially during mill transportation.

See Figure 5-12.

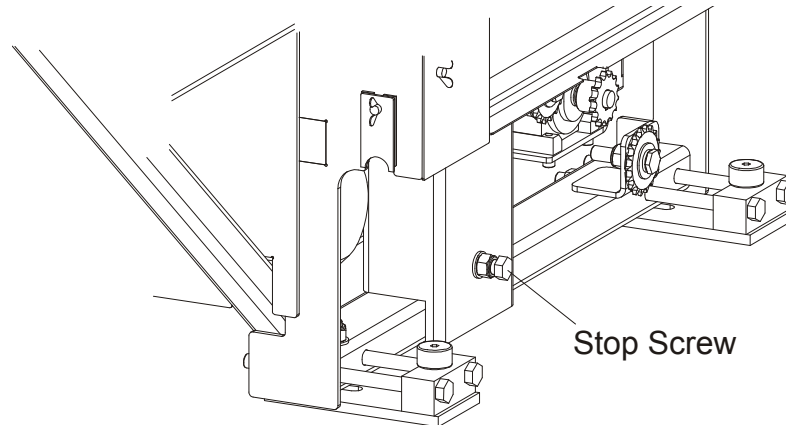

*FIG. 5-12*

## 5.6 Adjusting Bed Rails To The Blade

1. Adjust the front pivot bed rail 90° to the main bed tube.
2. Move the cutting head to center the blade over the front pivot bed rail.
3. Measure the distance from the top of the pivot rail to the bottom of the blade. Make this measurement at each end of the pivot rail.
4. The two measurements should be 15" (375 mm).
5. Loosen the locking set screws and turn the inner height adjustment nut to adjust the height of the inner end of the pivot rail.



See Figure 5-13.

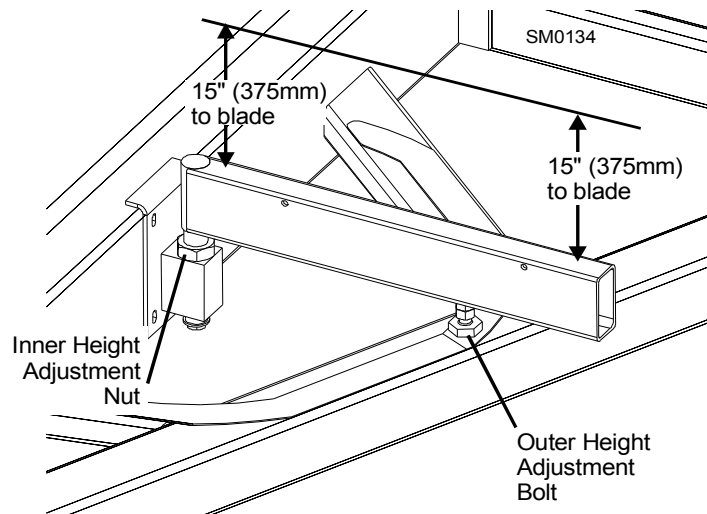

FIG. 5-13

6. Loosen the jam nut and turn the outer height adjustment bolt to adjust the height of the outer end of the pivot rail.
7. Move the cutting head so the blade is positioned over the center of the front main bed rail.
8. Measure the distance between the bottom of the blade and the bed rail at each end of the bed rail. The bed rail should measure 15" (375 mm) (+ 1.0 mm on the outer end) from the blade at each end of the rail.

See Figure 5-14.

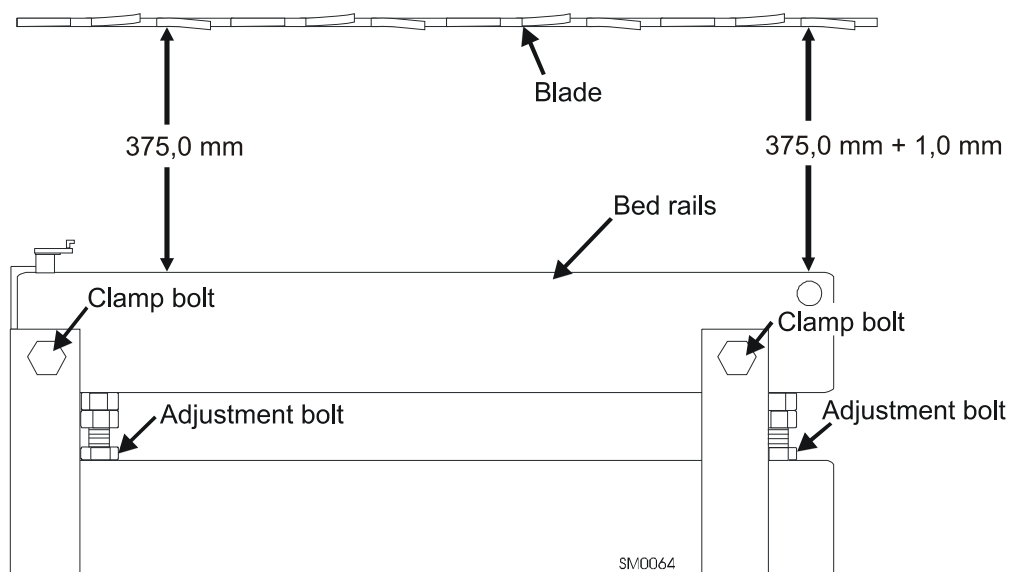

FIG. 5-14

9. Loosen the bed rail clamping bolts and turn the adjustment bolts to move the bed rails to the blade if necessary.
10. Retighten the clamping bolts and adjustment bolts.
11. Without adjusting the cutting head height, check the three remaining main bed rails and the rear pivot rail. Adjust them so that all measure the same distance from the blade at both ends of the bed rail.

## 5.7 Blade Guide Arm Vertical Adjustment

1. Move the cutting head so that the blade guide arm is directly over a bed rail.
2. Adjust the blade guide arm out to within 1/2" (15 mm) of full open.
3. Measure from the top of the bed rail to the arm.

See Figure 5-15.

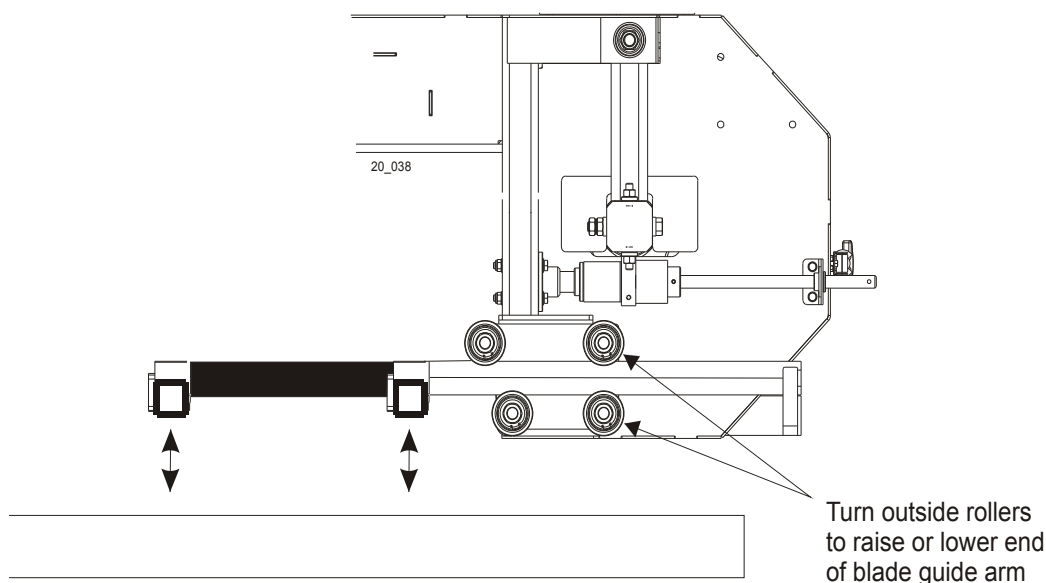

FIG. 5-15

4. Adjust the blade guide arm in to within 1/2" (15 mm) of full closed. Measure again from the top of the bed rail to the arm.
5. Adjust the arm so that the measurement from the top of the bed rail to the arm in the closed position is the same as the measurement from the top of the bed rail to the arm in the open position.

If the arm is too low in the closed position, loosen the lower outside roller and tighten the

upper outside roller ([See step 6.](#))

If the arm is too high in the closed position, loosen the upper outside roller and tighten the lower outside roller ([See step 6.](#))

6. The rollers are mounted on cam bolts that raise or lower the arm when turned.

To adjust the rollers, locate the cam bolt inside the housing and turn until the arm is lowered or raised as needed. Recheck the arm in both the open and closed positions. Repeat adjustments until the arm is the same distance from the bed rail in the open and closed position.

7. The blade guide arm should be snug, but not too tight, in the rollers. You should be able to move it in and out with firm hand pressure. There should be no side-to-side play.

## 5.8 Carriage Backlash Removal

Check the carriage for backlash every 200 hours of operation. If necessary, remove the backlash.

**See Figure 5-16.** To check if the backlash is present, grasp the outside part of the

*FIG. 5-16*

sawhead and move it as shown in the figure below. To remove the backlash, perform the following steps:

1. Loosen the nuts on the adjustment bolts and the set screws shown in Figure 5-17, adjust the mast guide rollers as shown in Figure 5-18.

2. Tighten the two adjustment bolts evenly to remove the backlash.

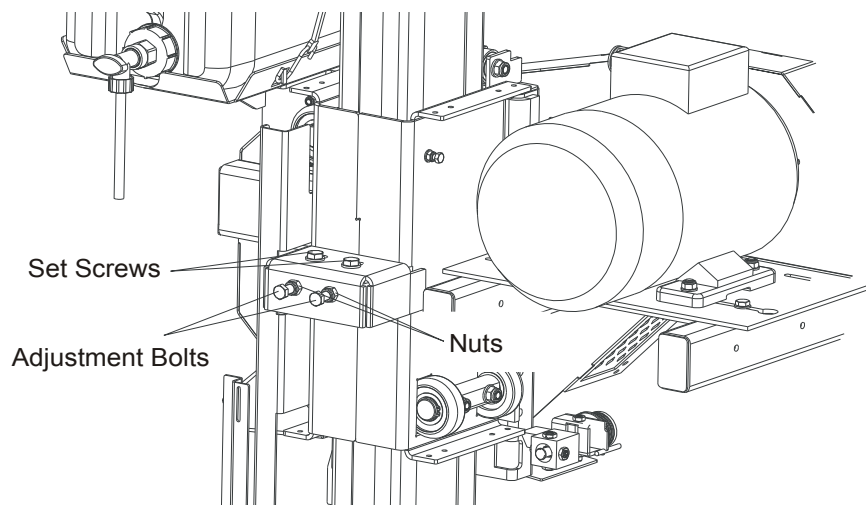

FIG. 5-17

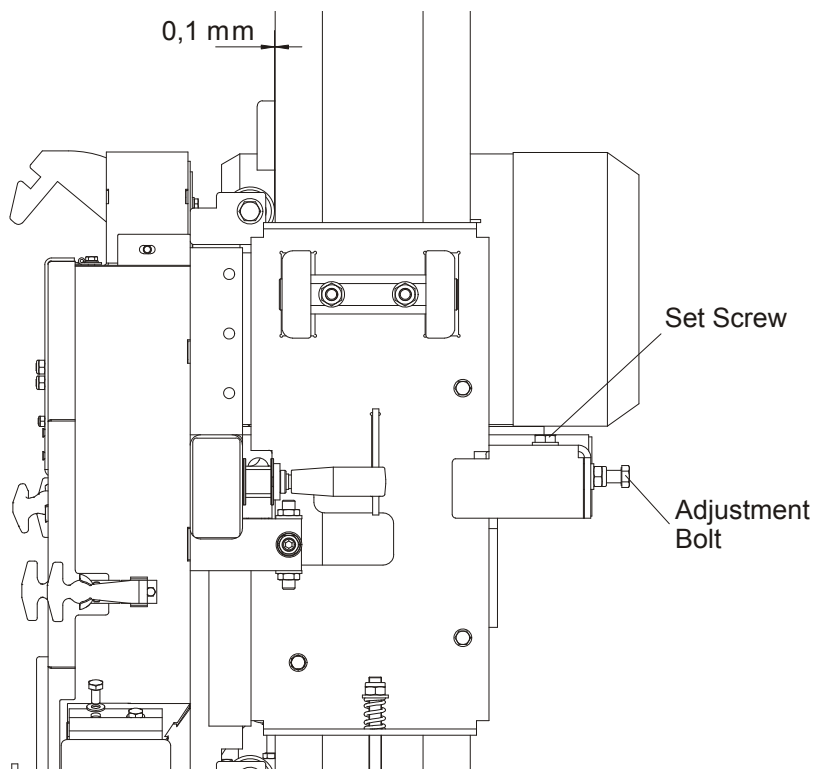

FIG. 5-18

3. Tighten the set screws and the nuts.



**CAUTION!** Do not overtighten the adjustment bolts.  
Damage to the up/down system may result.

## 5.9 Blade Guide Rope Adjustment

Adjust the blade guide rope tension when it gets too loose and begins slipping. To do this, use the adjustment nuts shown in Figure 5-19.

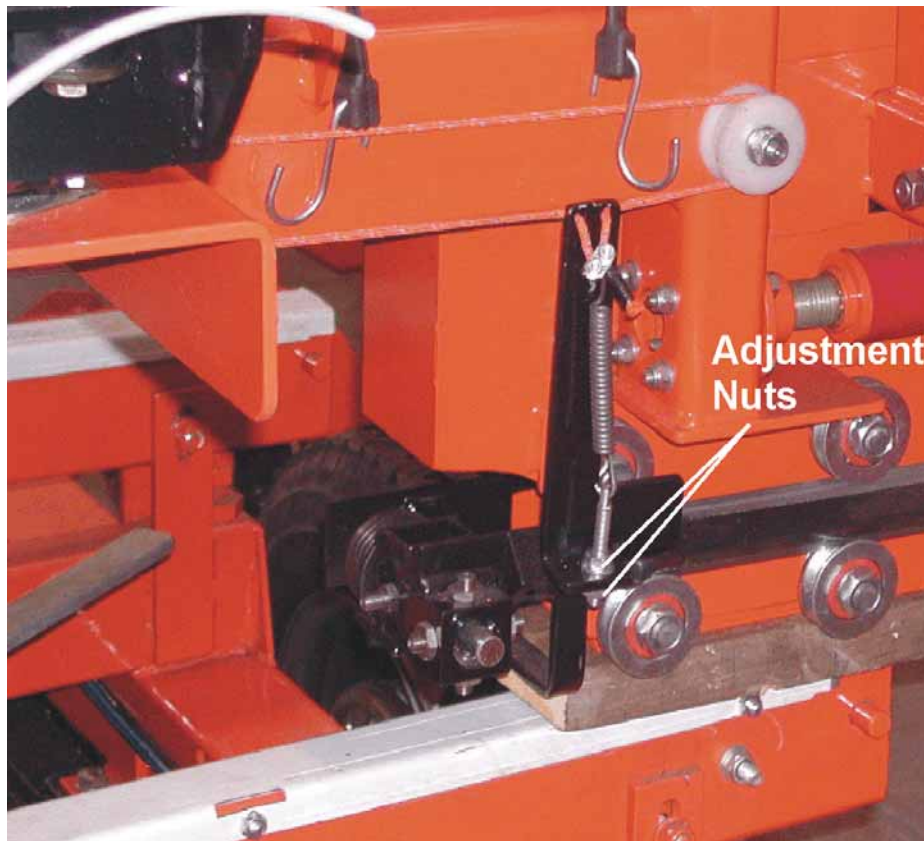

*FIG. 5-19*

## 5.10 Blade Guide Arm Horizontal Adjustment

1. Put the blade guide assembly back in the arm (if you took it out). Put the assembly back so that the flanged collar on the roller is about 3.0 mm (0.04") from the back of the blade when the arm is 15 mm (0.6") from full open.
2. Close the throat to within 15 mm (0.6") from fully closed. Check to see that the flange is the same distance from the back of the blade.

See Figure 5-20.

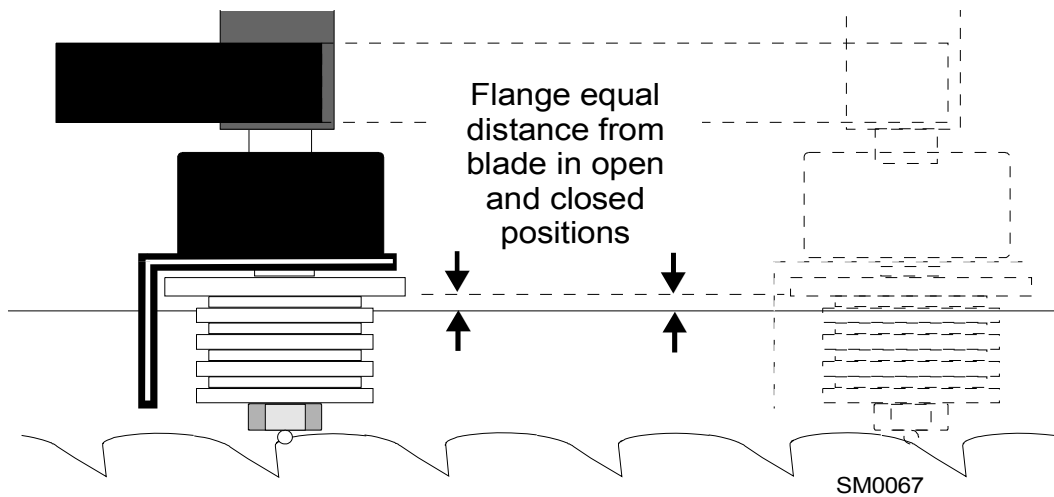

FIG. 5-20

3. If adjustment is needed, the guide rollers can be adjusted in or out on the threaded mounts to open or close the gap.

See Figure 5-21.

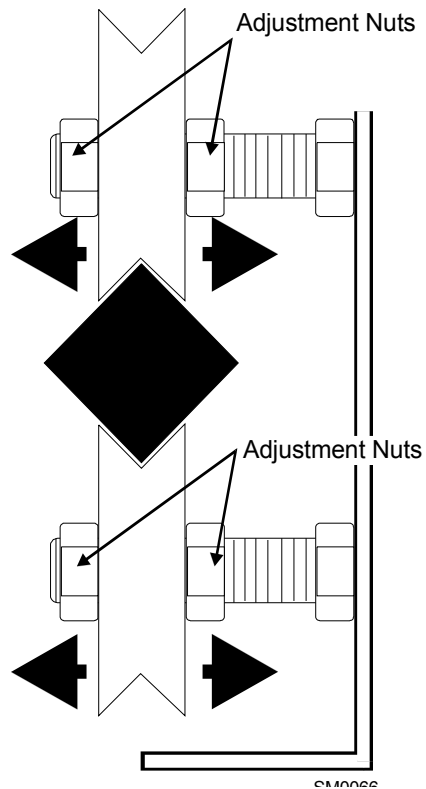

FIG. 5-21

4. Adjusting the outside two rollers (furthest from the arm motor) inward will cause the flange to move away from the blade.
5. Adjusting the two outside rollers outward will cause the flange to move toward the blade.
6. Adjust until the roller flange is the same distance from the back of the blade in the open and closed position.



## 5.11 Aligning the Blade Guides

Each Wood-Mizer sawmill has two blade guide assemblies that help the blade maintain a straight cut. The two blade guide assemblies are positioned on the cutting head to guide the blade on each side of the material being cut.

One blade guide assembly is mounted in a stationary position on the drive side of the cutting head. This assembly is referred to as the "inner" blade guide assembly.

The other blade guide assembly is mounted on the idle side of the cutting head. It is referred to as the "outer" assembly and is adjustable for various widths of materials to be processed.

Blade guide alignment includes four steps:

- Blade Deflection
- Blade Guide Vertical Tilt
- Blade Guide Flange Spacing
- Blade Guide Horizontal Tilt

Perform the blade guide alignment after you have aligned the blade on the wheels and adjusted the blade and blade guide arm parallel to the bed rails. After blade guide alignment, check the scale indicator to make sure it is adjusted properly ([See Section 5.19](#)).

**NOTE:** During blade guide alignment, remove the blade guide adjusting screws and apply a lubricating oil such as 10W30 or Dexron III to each screw. This will prevent the screws and threaded holes from corroding and make screw adjustments easier.

## 5.12 Blade Deflection

Perform the following steps to achieve proper blade deflection with the blade guides.

1. Raise the carriage until the blade is 375 mm (15") above a bed rail. Measure the actual distance with a tape from the top of the rail to the bottom of the blade.
2. Install the blade guides. Make sure the two set screws shown are threaded into the blade guide shaft until they touch each other.

See Figure 5-22.

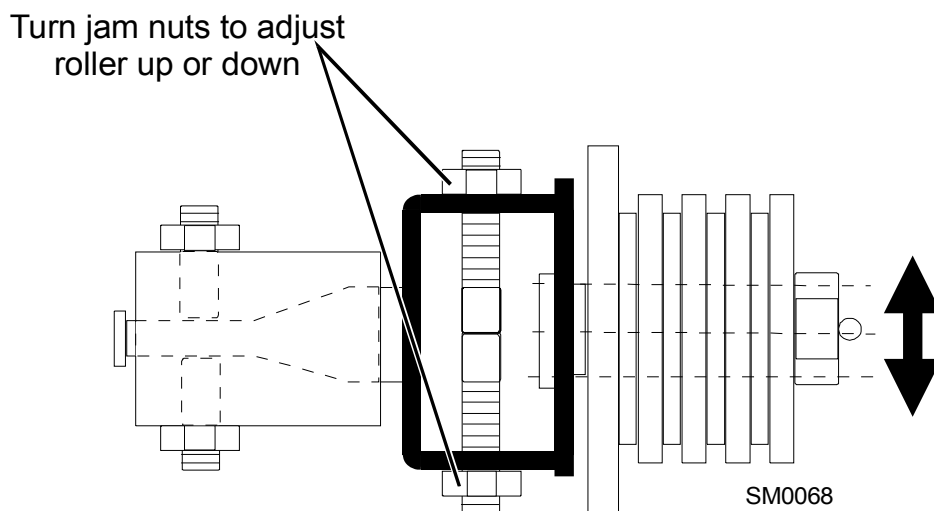

FIG. 5-22

3. Loosen the bottom jam nut and tighten the top jam nut until the blade guide deflects the blade down 6.0 mm (0.24").
4. Repeat for the other blade guide.

**NOTE:** Be sure that the blade guide touches the blade in both guide assemblies. The outer blade guide should be checked with the arm all the way in and all the way out.

### 5.13 Blade Guide Vertical Tilt Adjustment

Check that the blade guide does not tilt the blade up or down. A Blade Guide Alignment Tool (BGAT) is provided to help you measure the vertical tilt of the blade.

1. Open the blade guide arm 15 mm (0.6") from full open.
2. Clamp the alignment tool on the blade. Position the tool close to a blade guide roller. Be sure the tool does not rest on a tooth or burr, and is lying flat on the blade.

See Figure 5-23.

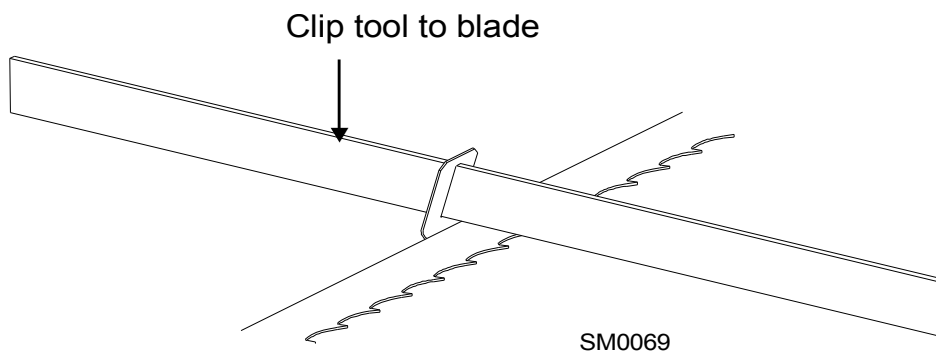
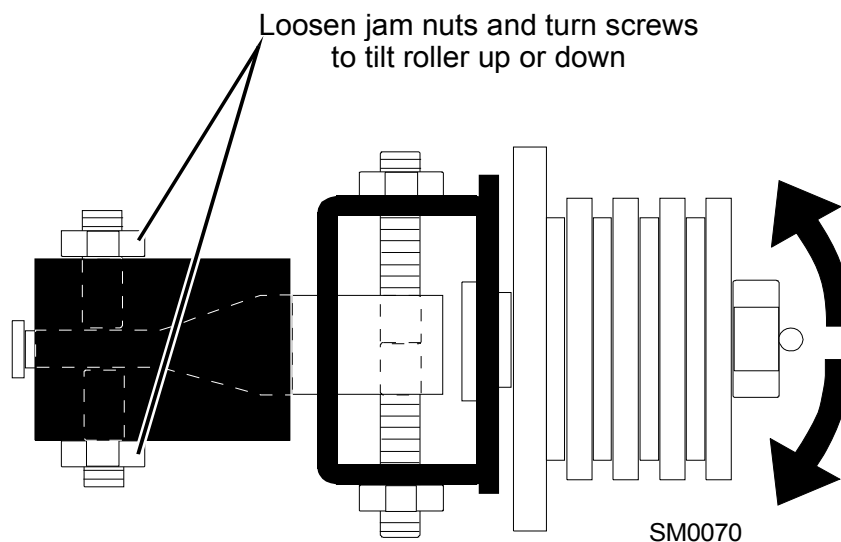

FIG. 5-23

3. Measure the distance from the bed rail to the bottom of the tool.  
**NOTE:** If the sawmill is equipped with stainless steel bed rail covers, be sure to measure from the blade guide alignment tool to the top surface of the cover rather than the bed rail tube.
4. Move the carriage so that the front end of the tool is positioned above the bed rail.
5. Measure the distance from the bed rail to the bottom edge of the tool.
6. Loosen one set screw at the side of the blade guide assembly.
7. Use the set screws shown to tilt the blade guide until the measurement from the bed rail to the tool equals the first measurement taken at the center of the tool.

See Figure 5-24.



*FIG. 5-24*

8. Move the carriage forward so the back end of the tool is over the bed rail.
9. Use the set screws shown to adjust the blade guide tilt until the measurement from the bed rail to the tool equals the other two measurements taken.
10. Move the tool close to the other blade guide and repeat the previous steps.

**NOTE:** If major adjustments to blade guide tilt were made, measure the distance between the blade and the bed rails again to ensure the correct 6.0 mm (0.24") blade guide deflection. Adjust if necessary.

## 5.14 Blade Guide Spacing

**HINT:** When adjusting blade guide spacing, loosen the top set screw and one side set screw only. This will ensure horizontal and vertical tilt adjustments are maintained when the set screws are retightened.

1. Adjust the inner blade guide so the blade guide flange is approximately 1.5 – 3.0 mm (0.06 - 0.12") from the back of the blade.
2. Loosen one side and one top set screw shown. Tap the blade guide forward or backward until properly positioned.

See Figure 5-25.

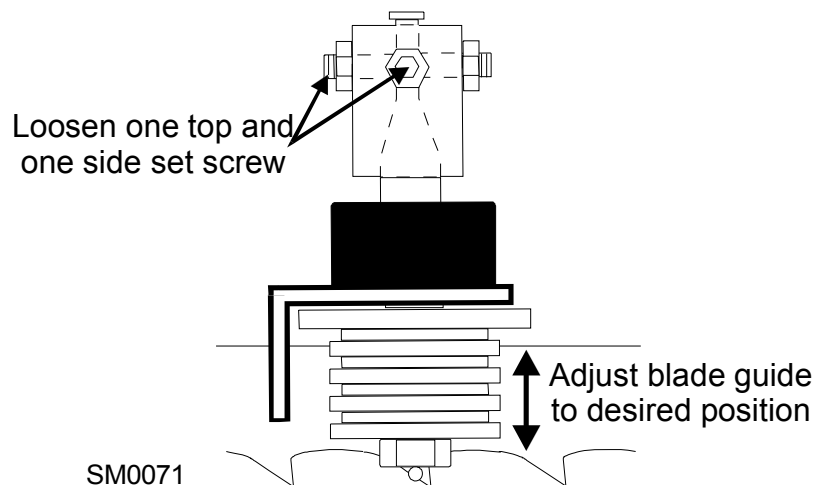

FIG. 5-25

3. Retighten the two set screws.
4. Adjust the outer blade guide in the same way so the blade guide flange is approximately 1.5 – 3.0 mm (0.06 - 0.12") from the back of the blade.

### 5.15 Horizontal Tilt Adjustment

1. Finally, both blade guides must be tilted horizontally. Adjust the blade guide arm halfway in.

See Figure 5-26.

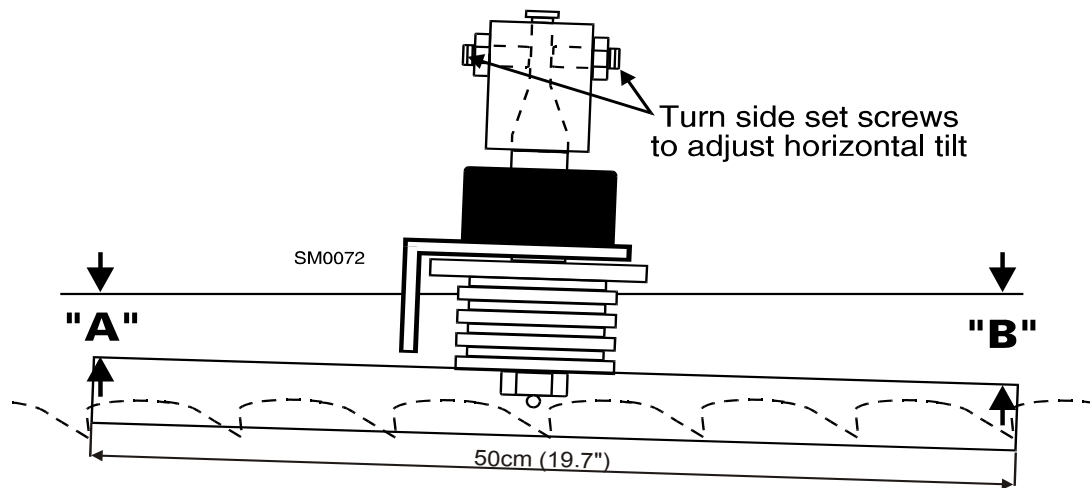

FIG. 5-26

2. Place the Blade Guide Alignment Tool against the face of the outer blade guide roller.
3. Center the tool on the roller and measure between the back edge of the blade and the ruler at the end closest to the inner blade guide ("B").
4. Measure between the back edge of the blade and the other end of the ruler ("A").
5. The roller should be tilted slightly to the left ( $A = B - 6.0 \text{ mm}[0.24"]$ ).
6. Use the side set screws to adjust the horizontal tilt of the roller.
7. Repeat steps 3-7 for the inner blade guide roller.

**NOTE:** Once the blade guides have been adjusted, any cutting variances are most likely caused by the blade. See the **Blade Handbook, Form #600**.

## 5.16 Horizontal Adjustment of Side Supports

Logs and boards are clamped against the side supports when sawing. The sides supports must be square to the bed to ensure square lumber.

1. Swing the side support down.
2. Measure distance between the face of the support and the main bed tube. Make measurements at both ends of the side support to make sure that it is parallel to the rail.

See Figure 5-27.

3. Use the two lower bolts to adjust the side support so  $B=A$ .
4. Repeat for remaining side supports.

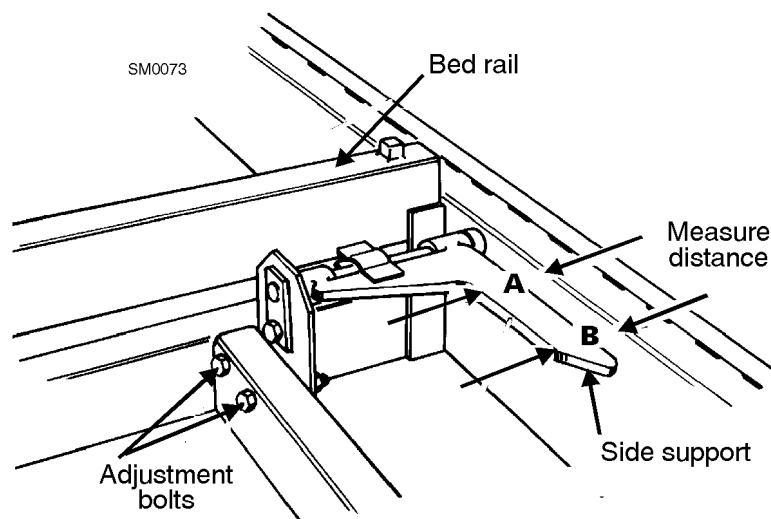
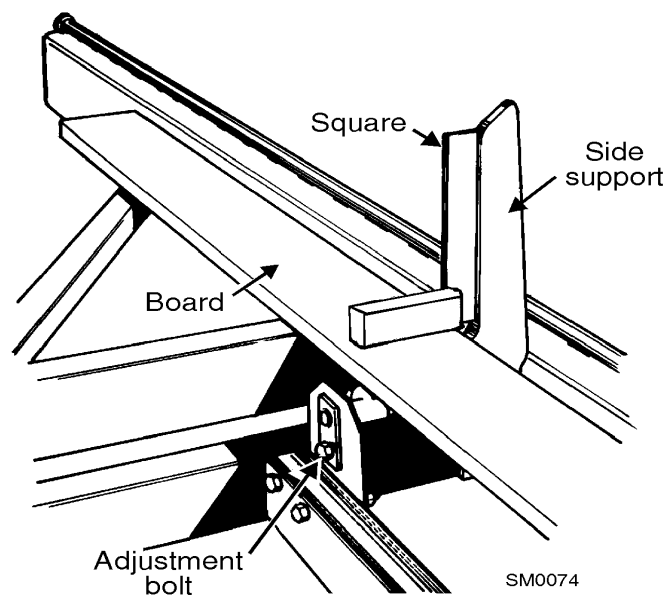

FIG. 5-27

### 5.17 Vertical Adjustment of Side Supports

1. Place a flat board across the bed rails.
2. Swing a side support up so that it is vertical.
3. Pull back at the top of the support to eliminate slack as if a log were being clamped against it.

See Figure 5-28.



*FIG. 5-28*

4. Check the angle of each support with a square on the board.
5. The side support should be 90° to the bed rails. Loosen the top adjustment bolt, adjust the side support, and retighten the bolt.
6. Repeat for the remaining side supports.



## 5.18 Saw Head Tilt

As the blade enters a wide log or cant, the outside of the saw head will drop down slightly. To compensate for the drop, use the lower track roller horizontal nuts to raise the outside of the saw head 1.5 mm (0.06").

1. Move the cutting head so the blade is positioned 375 mm (14.76") above a bed rail.
2. Adjust the lower track roller horizontal nuts until the blade measures 376 mm (14.80") from the bed rail near the outer blade guide.

See Figure 5-29.

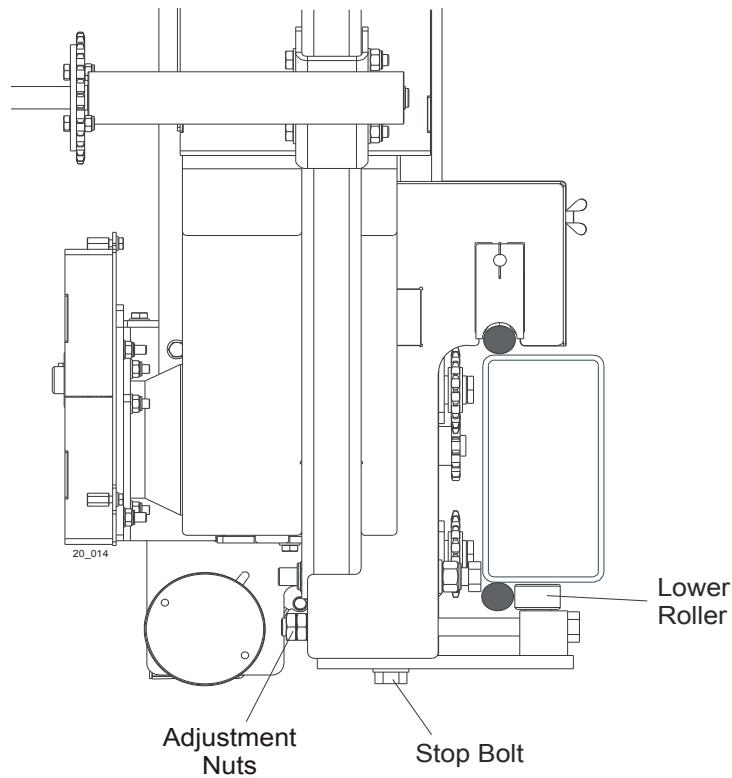
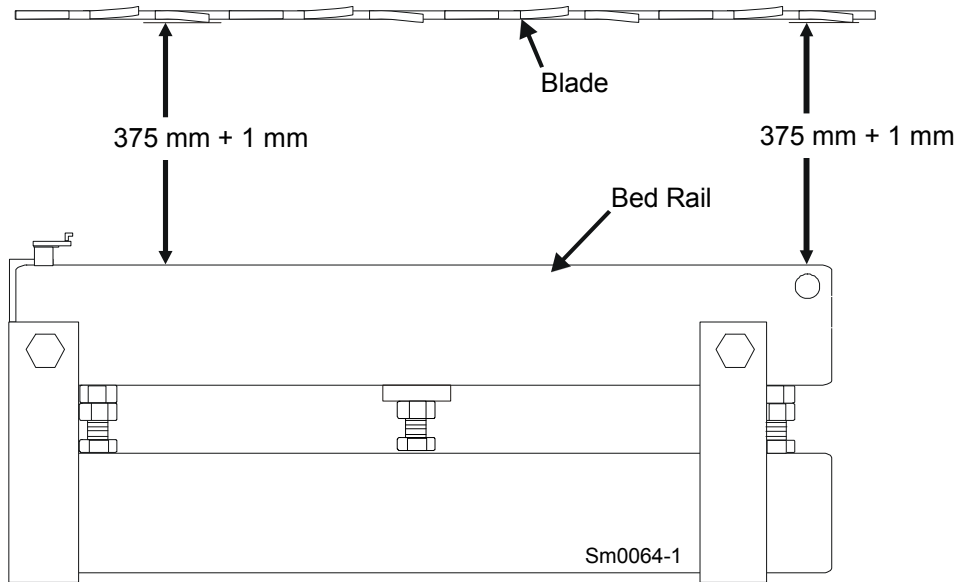

FIG. 5-29

# 5 SAWMILL ALIGNMENT

*Saw Head Tilt*

See Figure 5-30.



**FIG. 5-30**

## 5.19 Blade Height Scale Adjustment

After the entire sawmill has been aligned and all adjustments made, check that the blade height scale indicates the true distance from the blade to the bed rails.

1. Move the saw head so the blade is positioned directly above one of the bed rails. Measure from the bottom edge on a down-set tooth of the blade to the top of the bed rail (or stainless steel sleeve if applicable).

See Figure 5-31.

2. View the blade height scale with eyes level with the indicator.

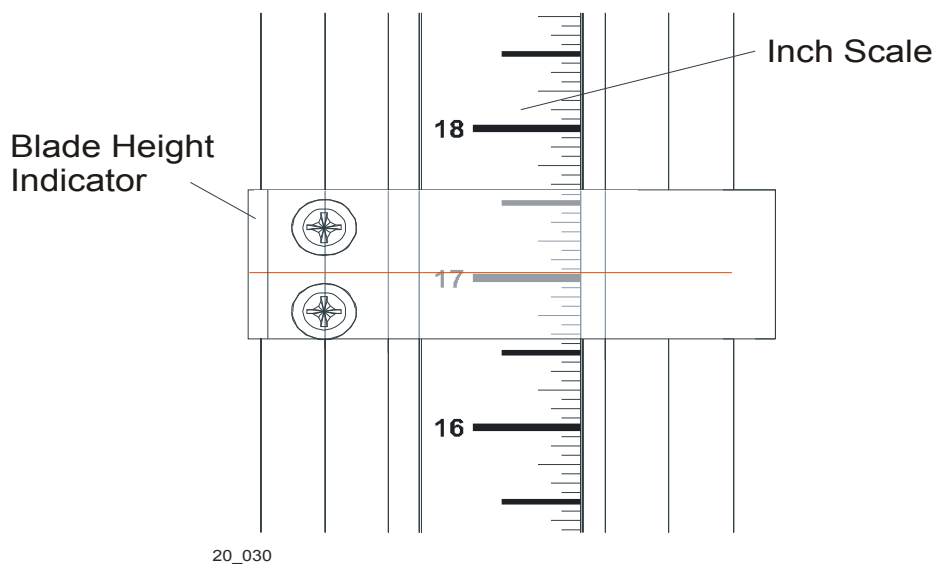

FIG. 5-31

3. Loosen the indicator bracket mounting bolts and adjust the bracket until the indicator is aligned with the correct mark on the scale. Retighten the bracket mounting bolts.

For example, if the measurement from blade to bed rail was 375 mm (14.76"), make sure the indicator reads 375 mm (14.76") on the scale.

## EC declaration of conformity according to EC Machinery Directive 2006/42/EC

We herewith declare,

Wood-Mizer Industries sp. Z O.O.  
114 Nagorna street, 62-600 Kolo; Poland.

That the following described machine in our delivered version complies with the appropriate basic safety and health requirements of the EC Machinery Directive 2006/42/EC based on its design and type, as brought into circulation by us. In case of alteration of the machine, not agreed by us, this declaration is no longer valid.

Designation of the machine:	<b>SAWMILL</b>
TYPE:	LT20
Model:	.....
No. of manufacturer:	.....
Applicable EC Directives:	EC Machinery Directive 2006/42/EC EC Low-Voltage Directive 2006/95/EC EC Electromagnetic Compatibility Directive 2004/108/EC
Applicable Harmonized Standards:	EN ISO 12100 : 2009, EN ISO 13857 : 2008; EN 349 : 2008; EN 1807 : 2009; EN 982 : 2008; EN 60204-1 : 2007.
Notified Body according to annex IV:	PZ.LSV; Pruf- und Zertifizierungsstelle des Spitzenverbandes der landwirtschaftlichen Sozialversicherung
Notification No	2157
Responsible for:	EC type examination
EC type-examination certificate no.	LSV-EG-2010/123
Responsible for Technical Documentation	Roman Frontczak / R&D Director
Date/Authorized Signature:	26.01.2010 
Title:	R&D Director