

# **Wood-Mizer®**

## **Replacement Parts Manual**

---

**HR110**

**rev.A1.00**

---



**Safety is our #1 concern!** Read and understand all safety information and instructions before operating, setting up or maintaining this machine.

*September 2010*

*Form #927*

<b>SECTION 1</b>	<b>GENERAL INFORMATION</b>	<b>1-1</b>
1.1	How To Use The Parts List.....	1-1
1.2	Sample Assembly.....	1-1
<b>SECTION 2</b>	<b>BLADE GUIDE ROLLERS &amp; ARM</b>	<b>2-1</b>
2.1	Blade Guide Assembly, Idle Side .....	2-1
2.2	Blade Guide Assembly, Drive Side .....	2-3
2.3	Blade Guide Roller Guard.....	2-5
2.4	Blade Guide Arm Assembly .....	2-6
<b>SECTION 3</b>	<b>BLADE WHEELS &amp; TENSIONER</b>	<b>3-1</b>
3.1	Blade Wheel Assembly, Drive Side.....	3-1
3.2	Blade Wheel Assembly, Idle Side.....	3-2
3.3	Blade Tensioner Assembly .....	3-3
3.4	Motor.....	3-4
<b>SECTION 4</b>	<b>SAW HEAD &amp; FEED TRACK</b>	<b>4-1</b>
4.1	Blade Housing Cover .....	4-1
4.2	Water Lube Assembly.....	4-3
4.3	Decals, HR110 .....	4-4
4.4	Control Panel, HR110.....	4-6
4.5	Electric Box Decals.....	4-7
4.6	Hold-Down Roller Assembly.....	4-8
4.7	Infeed, Outfeed & Return Tables .....	4-9
4.8	Feed Track Assembly.....	4-11
<b>SECTION 5</b>	<b>UP/DOWN SYSTEM</b>	<b>5-1</b>
5.1	Up/Down Crank Assembly .....	5-1
5.2	Up/Down Drive Sprocket Assembly.....	5-2
5.3	Slide Pads and Blade Height Scale Indicator.....	5-4
5.4	Blade Height Scale (Optional) .....	5-6

## SECTION 1 GENERAL INFORMATION

### 1.1 How To Use The Parts List

- Use the index above to locate the assembly that contains the part you need.
- Go to the appropriate section and locate the part in the illustration.
- Use the number pointing to the part to locate the correct part number and description in the table.
- Parts shown indented under another part are included with that part.
- Parts marked with a diamond (◆) are only available in the assembly listed above the part.

See the sample table below. Sample Part #A01111 includes part F02222-2 and subassembly A03333. Subassembly A03333 includes part S04444-4 and subassembly K05555. The diamond (◆) indicates that S04444-4 is not available except in subassembly A03333. Subassembly K05555 includes parts M06666 and F07777-77. The diamond (◆) indicates M06666 is not available except in subassembly K05555.

1.2 Sample Assembly				
REF	DESCRIPTION (◆ Indicates Parts Available In Assemblies Only)	PART #	QTY.	
	Sample Assembly, Complete (Includes All Indented Parts Below)	A01111	1	
1	Sample Part	F02222-22	1	
	Sample Subassembly (Includes All Indented Parts Below)	A03333	1	
2	Sample Part (◆ Indicates Part Is Only Available With A03333)	S04444-4	1	◆
	Sample Subassembly (Includes All Indented Parts Below)	K05555	1	
3	Sample Part (◆ Indicates Part Is Only Available With K05555)	M06666	2	◆
4	Sample Part	F07777-77	1	

#### To Order Parts:

- From Europe call our European Headquarters and Manufacturing Facility in Kolo, Poland at **+48-63-2626000**. From the continental U.S., call our toll-free Parts hotline at **1-800-448-7881**. Have your customer number, vehicle identification number, and part numbers ready when you call.
- From other international locations, contact the Wood-Mizer distributor in your area for parts.



**CAUTION!** It is strongly recommended to use original spare parts only.



# General Information

*Sample Assembly*

---



**SECTION 2 BLADE GUIDE ROLLERS & ARM**

**2.1 Blade Guide Assembly, Idle Side**

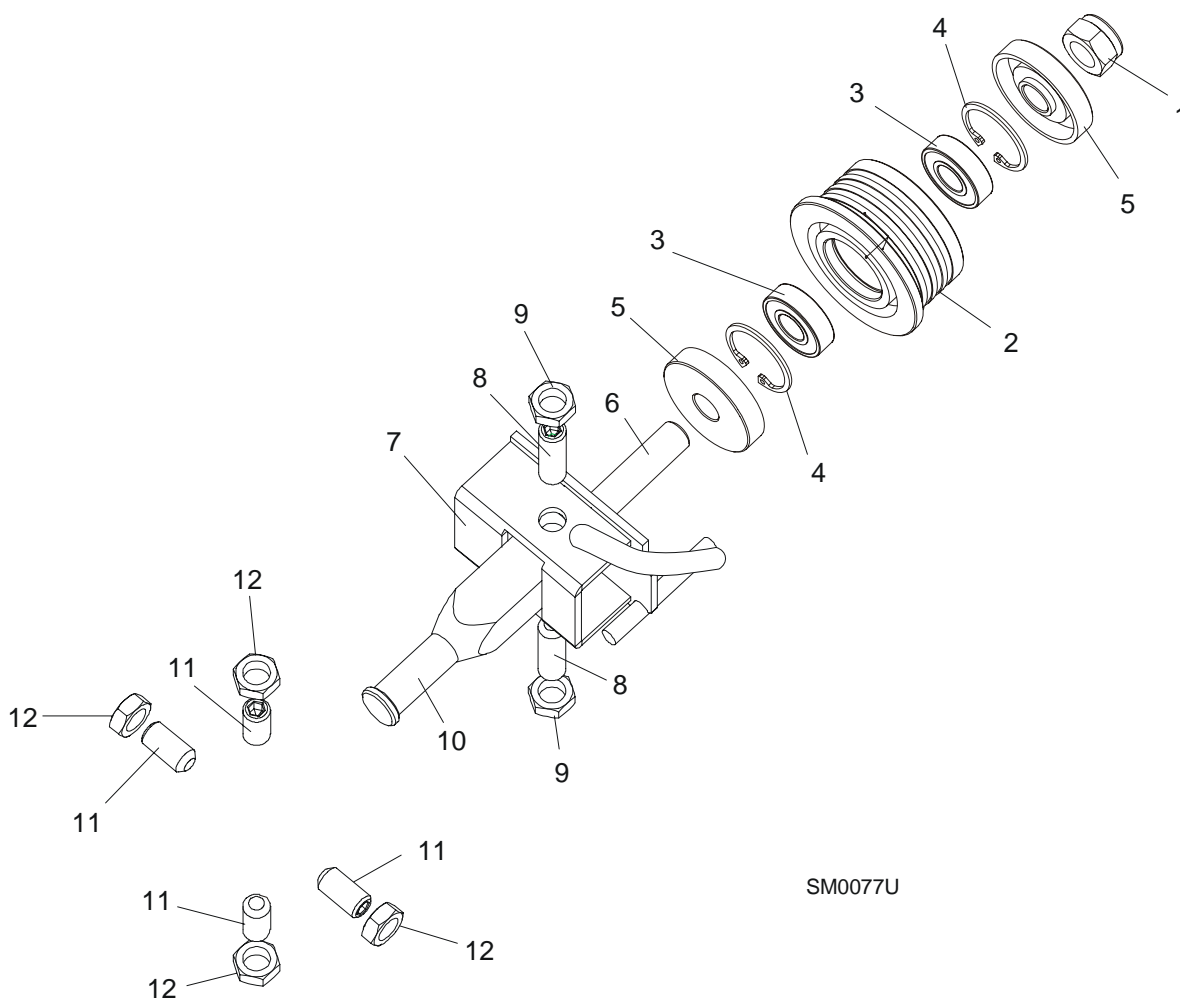

SM0077U

REF	DESCRIPTION (◆ Indicates Parts Available In Assemblies Only)	Part #	Qty.	
	<b>BLADE GUIDE ASSEMBLY, IDLE SIDE</b>	094683	1	
	Roller Assembly, Standard Blade Guide	087887	1	
1	Nut, M12-8 Hex Nylon Lock Nut	F81034-2	1	
2	Roller, Narrow Blade Guide	087889	1	◆
3	Bearing, 6001 2RSR FAG	087893	2	
4	Ring, W28 Inside Retaining	F81090-9	1	
5	Washer, Zinc-plated Spacer	087891-1	2	
6	Shaft, Standard Blade Guide Roller Zinc	087763-1	1	
7	Bracket Weldment, Idle Side Blade Guide Painted	094681-1	1	
8	Screw, M10x1x40 DIN 913 A2-70 Stainless Steel Set	F81015-2	2	

# BLADE GUIDE ROLLERS & ARM

## *Blade Guide Assembly, Idle Side*

3

9	Nut, M10x1-04-ST-A2 ISO 8675 Thin	F81033-10	2	
10	Shaft, Zinc-plated Blade Guide Mount	088255-1	1	
11	<b>SCREW, M10X1X20 DIN 913 STAINLESS STEEL SET</b>	F81015-1	4	
12	<b>NUT, M10x1-04-ST-A2 ISO 8675 THIN</b>	F81033-10	4	

**2.2 Blade Guide Assembly, Drive Side**

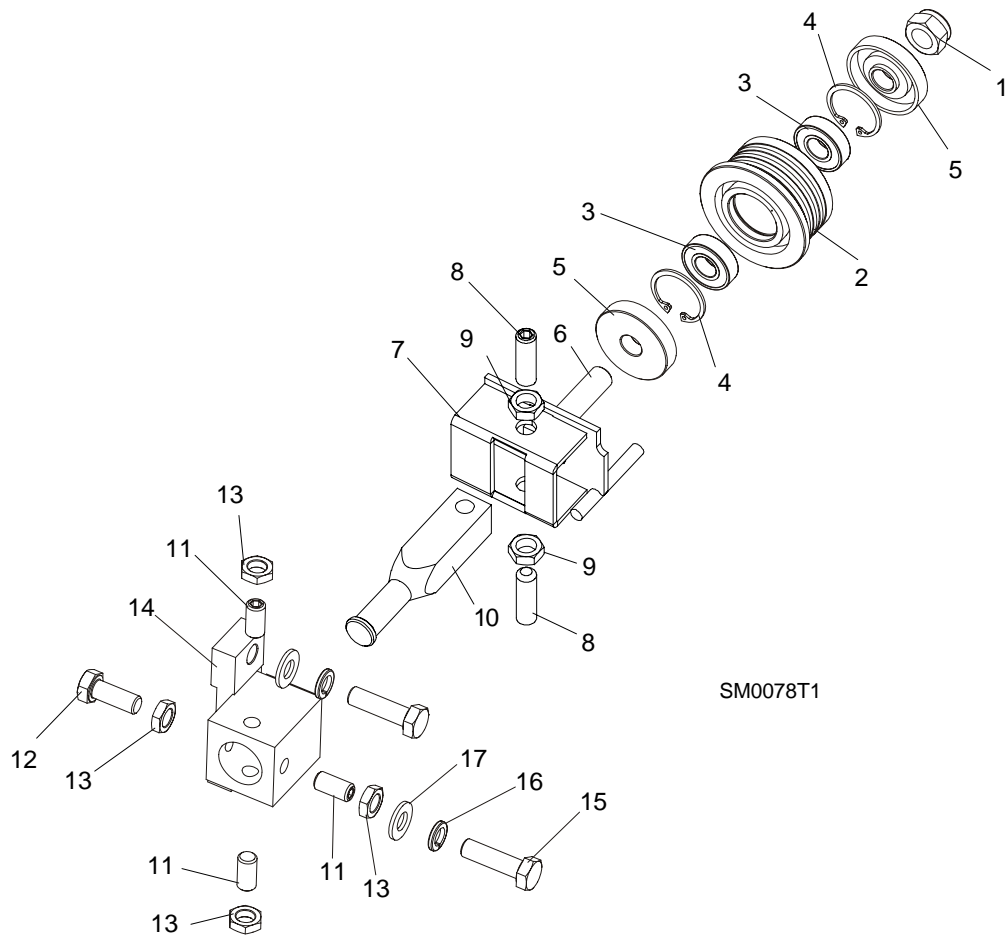

REF	DESCRIPTION (◆ Indicates Parts Available In Assemblies Only)	Part #	Qty.	
	<b>BLADE GUIDE ASSEMBLY DRIVE SIDE</b>	094682	1	
	Roller Assembly, Standard Blade Guide	087887	1	
1	Nut, M12-8 Hex Nylon Lock Nut	F81034-2	1	
2	Roller, Narrow Blade Guide	087889	1	◆
3	Bearing, 6001 2RSR FAG	087893	2	
4	Ring, W28 Inside Retaining	F81090-9	1	
5	Washer, Zinc-plated Spacer	087891-1	2	
6	Shaft, Standard Blade Guide Roller Zinc	087763-1	1	
7	Bracket Weldment, Blade Guide Painted	094679-1	1	
	Screw Kit, Blade Guide Adjustment w/Nuts (for two blade guide assemblies)	K09942	1	
8	Screw, M10x1x40 DIN 913 A2-70 Stainless Steel Set	F81015-2	2	
9	Nut, M10x1-04-ST-A2 ISO 8675 THIN	F81033-10	2	
10	Shaft, Zinc-plated Blade Guide Mount	088255-1	1	



# BLADE GUIDE ROLLERS & ARM

*Blade Guide Assembly, Drive Side*

3

11	SCREW, M10X1X20 DIN 913 SET STAINLESS STEEL	F81015-1	3	
12	BOLT, M10X1X25 DIN 933 STAINLESS STEEL	F81003-28	1	
13	NUT, M10x1-04-ST-A2 ISO 8675 THIN	F81033-10	4	
14	TUBE, BLADE GUIDE MOUNT	087744	1	
15	BOLT, M10X35-8.8 HEX HEAD FULL THREAD ZINC	F81003-17	2	
16	WASHER, 10.2 SPLIT LOCK ZINC	F81055-2	2	
17	WASHER, 10.5 FLAT ZINC	F81055-1	2	

## 2.3 Blade Guide Roller Guard

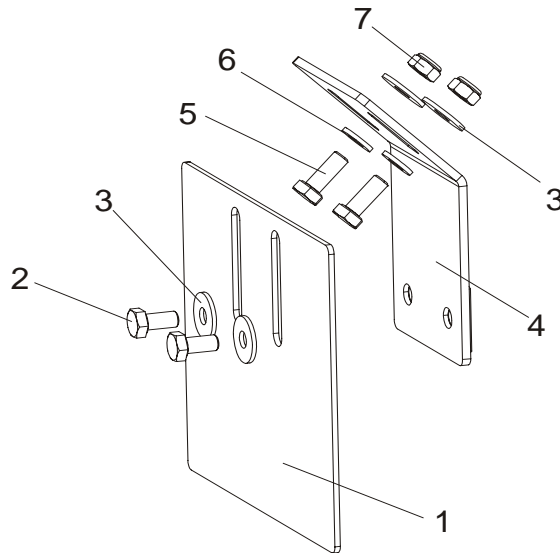

REF	DESCRIPTION (◆ Indicates Parts Available In Assemblies Only)	Part #	Qty	
1	GUARD, BLADE GUIDE ROLLER PAINTED	092379-1	1	
2	BOLT, M6X12-8.8 HEX HEAD FULL THREAD ZINC	F81001-7	2	
3	WASHER, 6,5 SPECIAL FLAT ZINC	F81053-11	4	
4	BRACKET, ROLLER GUARD MOUNT PAINTED	092378-1	1	
5	SCREW, M6X16 8.8 HEX HEAD FULL THREAD ZINC	F81001-15	2	
6	WASHER, 6.4 FLAT ZINC	F81053-1	2	
7	NUT, M6-8-B HEX NYLON ZINC LOCK	F81031-2	2	

2.4 Blade Guide Arm Assembly

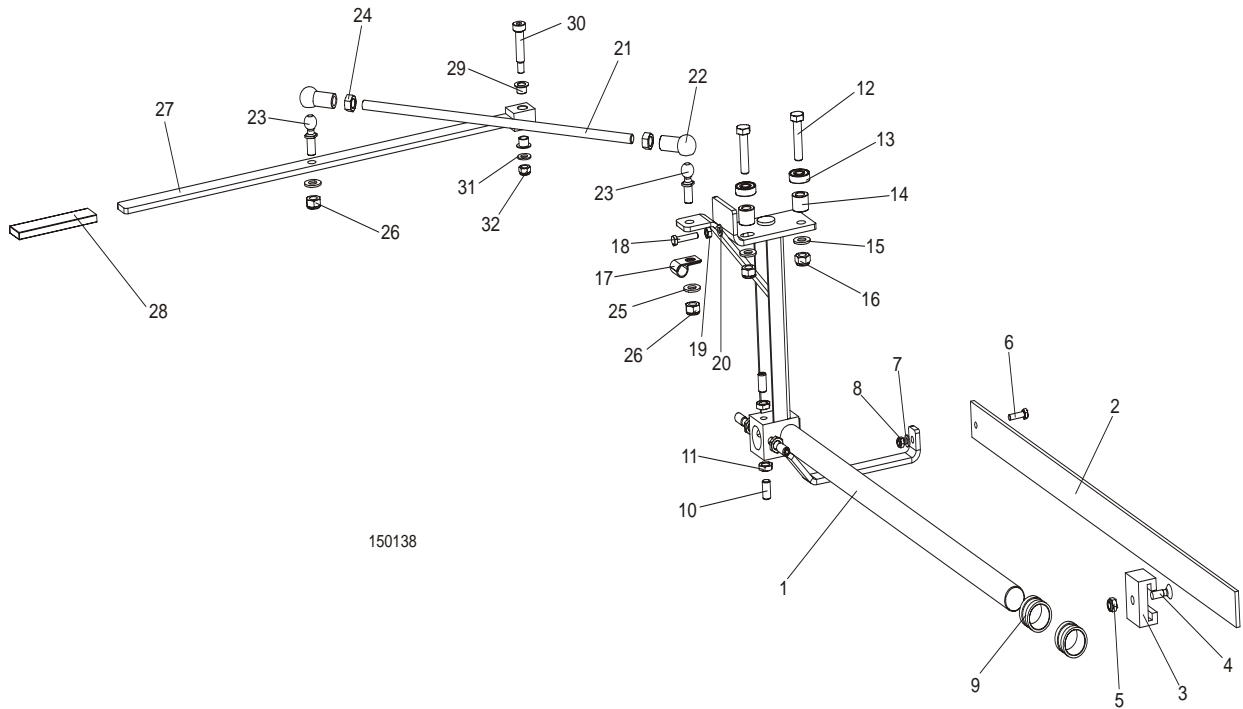

REF	DESCRIPTION (◆ Indicates Parts Available In Assemblies Only)	Part #	Qty
	<b>BLADE GUIDE ARM W/LEVER - COMPLETE</b>	094136	1
1	Arm weldment, LT10 Blade Guide	086662	1
2	Bar, Blade Guard	088306	1
3	Guide, Blade Guard	088305	1
4	Screw, M8x25 Cross Recessed Countersunk Head Zinc	F81002-51	1
5	Nut, M8-8-B-FeZn5 Hex Nylon Zinc Lock	F81032-2	1
6	Bolt, M6x20-8.8 Hex Head Full Thread Zinc	F81001-2	1
7	Washer, 6.4 Flat Zinc	F81053-1	1
8	Nut, M6-8-B Hex Nylon Zinc Lock	F81031-2	1
9	Bushing, LT10 Blade Guide	086684	1
10	Screw, M10x1x20 DIN913 Set Stainless Steel	F81015-1	4
11	NUT, M10x1-04-ST-A2 ISO 8675 Thin	F81033-10	4
12	Bolt, M10x45-8.8 Hex Head Full Thread Zinc	F81003-3	2
13	Bearing 6000.2RSR FAG	087471	2
14	Bushing, Zinc-Plated Spacer	094255-1	2
15	Washer, 10.5 Flat Zinc	F81055-1	2
16	Nut, M10-8-B Hex Nylon Zinc Lock	F81033-1	2
17	Clamp, 1/2" EMT Coated	P07584	1
18	Bolt, M6x30 5.8 Hex Head Full Thread	F81001-13	1
19	Nut, M16-8 Hex Nylon Zinc Lock	F81031-1	1
20	Washer, 6.4 Flat Zinc	F81053-1	1
	Stud Bolt Assembly, Arm Lever Connection	094204	1

## 3

**BLADE GUIDE ROLLERS & ARM***Blade Guide Arm Assembly*

21	Bolt, Zinc-Plated Stud	094203-1	1	
22	Seat, 16 DIN71805-A BN488 Ball	093824	2	
23	Stud, 16/SW-13 DIN71803-C BN486 BALL	093823	2	
24	Nut, M10-8-B Hex Zinc	F81033-3	2	
25	Washer, 10.5 Flat Zinc	F81055-1	2	
26	Nut, M10-8-B Hex Nylon Zinc Lock	F81033-1	2	
	Lever Assembly, Blade Guide Arm Adjustment	093812	1	
27	Lever, Blade Guide Arm Adjustment Painted	093813-1	1	
28	Cover, RRWA-91626-110 Grip	086875	1	
29	Bushing, TUF1 18X120 CX	500106	2	
30	Bolt, 10/M8x35 12.9 ISO7379 Shoulder	F81003-63	1	
31	Washer, 8.4 Flat Zinc	F81054-1	1	
32	Nut, M8-8-B hex nylon zinc lock	F81032-2	1	

**SECTION 3 BLADE WHEELS & TENSIONER**

**3.1 Blade Wheel Assembly, Drive Side**

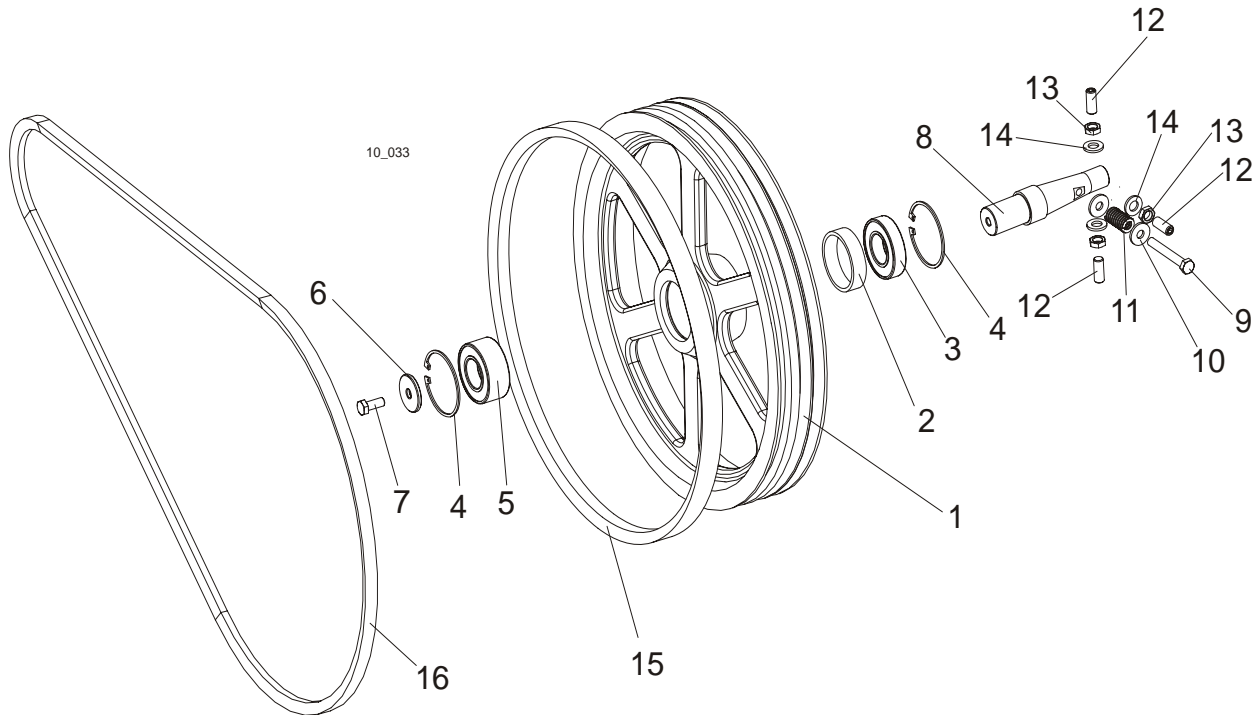

REF	DESCRIPTION (◆ Indicates Parts Available In Assemblies Only)	PART #	QTY.
	<b>WHEEL ASSEMBLY, DRIVE SIDE BLADE</b>	091612	1
1	BLADE WHEEL, DRIVE SIDE PTD	090646-1	1
2	BUSHING, SPACER	096778	1
3	BEARING, 6207 2RS 35X72X17 FAG	014811	1
4	RING, W72 INSIDE RETAINING	F81090-4	2
5	BEARING, 3207B, 2RSR TVH FAQ	P04185	1
6	<b>WASHER, DRIVE SIDE BLADE WHEEL</b>	092006	1
7	<b>SCREW, M10X25-8.8 HEX HEAD FULL THREAD ZINC</b>	F81003-11	1
8	<b>SHAFT, DRIVE SIDE BLADE WHEEL</b>	093850	1
9	<b>BOLT, M10X75-8.8 HEX HEAD ZINC</b>	F81003-15	1
10	<b>WASHER, 10.5 SPECIAL FLAT ZINC</b>	F81055-6	2
11	<b>SPRING, 19X38 COMPRESSION</b>	034430	1
12	<b>SCREW, M12X1,25X30 DIN913 SET STAINLESS STEEL</b>	F81016-1	3
13	<b>WASHER, 13 FLAT ZINC</b>	F81056-1	3
14	<b>NUT, M12X1.25 DIN439 THIN STAINLESS STEEL</b>	F81034-9	3
15	<b>V-BELT, B57</b>	P04185	1
16	<b>DRIVE BELT, BX81</b>	014819	1

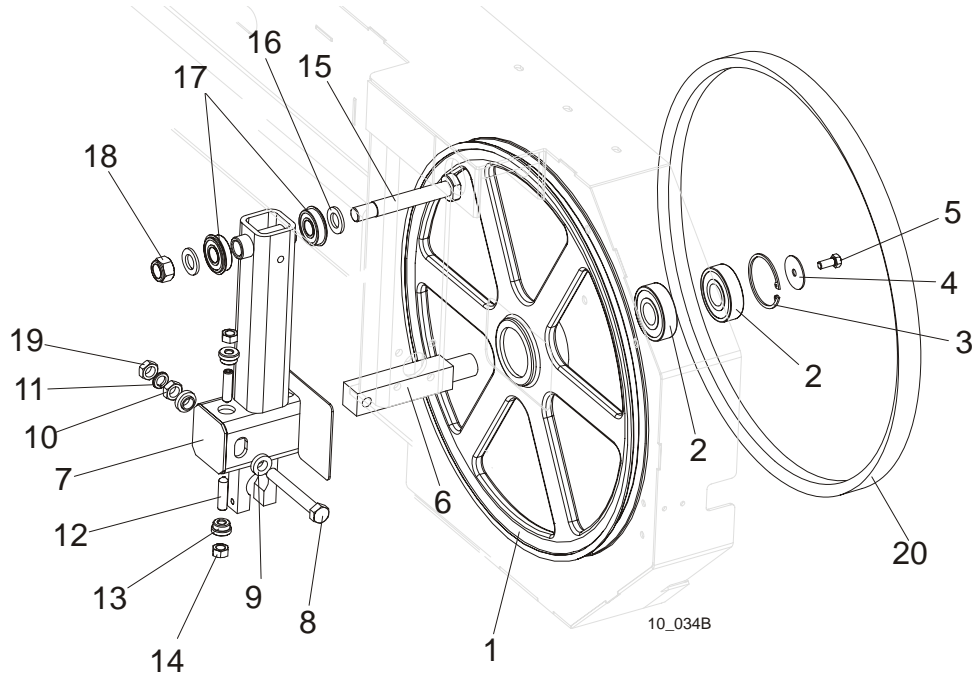
**3.2 Blade Wheel Assembly, Idle Side**

REF	DESCRIPTION (◆ Indicates Parts Available In Assemblies Only)	PART #	QTY.
	<b>WHEEL ASSEMBLY, IDLE SIDE BLADE</b>	A08218	1
1	WHEEL ASSEMBLY, 18.62" BLADE IDLE SIDE	P08125	1
2	BEARING, 6305 2RS NSK IDLE SIDE WHEEL	P08066	2
3	RING, 2 7/16" INSIDE RETAINING	F04254-21	1
	<b>HOUSING, LT10 &amp; LT15 IDLER SHAFT, COMPLETE</b>	100180	1
4	WASHER, IDLE SIDE WHEEL RETAINING	093854-1	1
5	BOLT, M8X25-8.8-B HEX HEAD FULL THREAD ZINC	F81002-5	1
6	SHAFT, IDLE SIDE BLADE WHEEL (METRIC)	096045	1
7	HOUSING, IDLER SHAFT	093857-1	1
8	BOLT, M12X1,25X100-8.8 HEX HEAD FULL THREAD ZINC	F81004-41	1
9	WASHER, FLANGED ZINC-PLATED	086769-1	2
10	NUT, M12X1,25 -8 HEX ZINC	F81034-8	1
11	WASHER, 12.2 SPLIT LOCK ZINC	F81056-2	1
12	SCREW, M10X40-45H CONE POINT HEX SOCKET	F81003-61	2
13	BUSHING, M10 IDLER SHAFT HOUSING	086987	2
14	NUT, M10-8-B HEX HEAD ZINC	F81033-3	2
15	PIN, IDLER ARM MOUNT	086404	1
16	WASHER, 17 FLAT ZINC	F81058-1	2
17	BEARING, 6203-2RS NR NSK W/SNAP RING	086395	2
18	NUT, M16-8 HEX NYLON ZINC LOCK	F81036-2	1
19	NUT, M12X1.25 DIN439 THIN STAINLESS STEEL	F81034-9	1
20	V-BELT, B57	P04185	1

**3.3 Blade Tensioner Assembly**

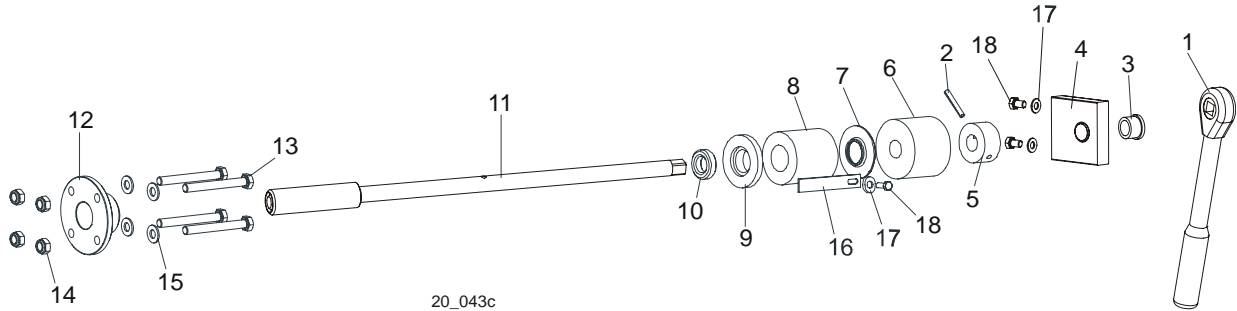

REF	DESCRIPTION (◆ Indicates Parts Available In Assemblies Only)	PART#	QTY.
	<b>BLADE TENSIONER ASSEMBLY</b>	090587	1
1	Wrench, LT20 Blade Tension	091620	1
2	Pin, 5 x 30 Zinc Roll	F81044-21	1
3	Bracket, Tension Handle Mount w/Bushing	096729	1
4	Bracket, Painted	096730	1
5	Collar, Blade Tensioner	086712-1	1
6	Bushing, Rubber Stop	P12165	1
7	Guide, LT15 Tension Handle	014925	1
8	Spring, LT15 Rubber Blade Tensioner	014828	1
9	Washer, Rubber Spring Front	086674-1	1
10	Bearing, 51103 FLT Ball Thrust	086675	1
11	Shaft Weldment, Blade Tensioner Zinc-plated	101338-1	1
12	Nut, Blade Tensioner	086672-1	1
13	Bolt, M8x70 8.8 Hex Head Zinc	F81002-71	4
14	Nut, M8-8-B Hex Nylon Zinc Lock	F81032-2	4
15	Washer, 8.4 Zinc Flat	F81054-1	8
16	Indicator, LT15 Blade Tension Zinc-plated	086783-1	1
17	Washer, 6.4 Zinc Flat	F81053-1	1
18	Bolt, M6x16 8.8 Hex Head Full Thread Zinc	F81001-15	1

## 3.4 Motor

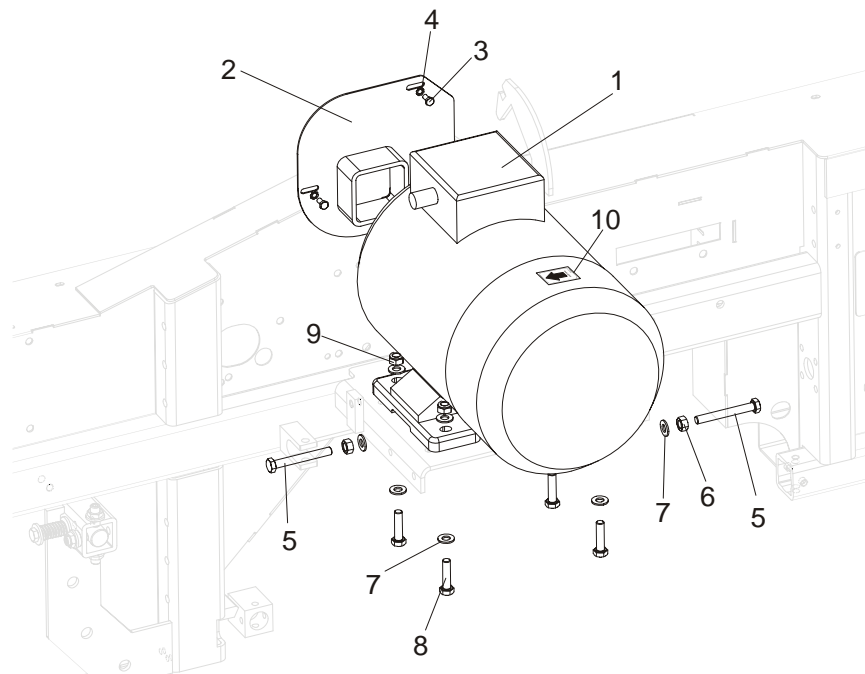

REF	DESCRIPTION (◆ Indicates Parts Available In Assemblies Only)	Part #	Qty.
1	MOTOR, 1LA7130-2AA60 5,5KW,400V,50HZ ELECTRIC	095785	1
2	MOTOR SHAFT COVER, E11 E15 PAINTED	095335-1	1
3	BOLT, M6X12-8.8 HEX HEAD FULL THREAD ZINC	F81001-7	3
4	WASHER, 6.4 STAR LOCK ZINC	F81053-2	3
5	BOLT, M10X80-8.8 HEX HEAD FULL THREAD ZINC	F81003-76	2
6	NUT, M10-8-B HEX ZINC	F81033-3	2
7	WASHER, 10.5 FLAT ZINC	F81055-1	10
8	BOLT, M10X40-8.8 HEX HEAD FULL THREAD ZINC	F81003-16	4
9	NUT, M10-8-B NYLON HEX ZINC LOCK	F81033-1	4
10	DECAL, ROTATION DIRECTION - 2925 RPM	S20097F <sup>1</sup>	1

<sup>1</sup> Included in 099419 - LT10 Pictographic Decal Kit.



## SECTION 4 SAW HEAD & FEED TRACK

### 4.1 Blade Housing Cover

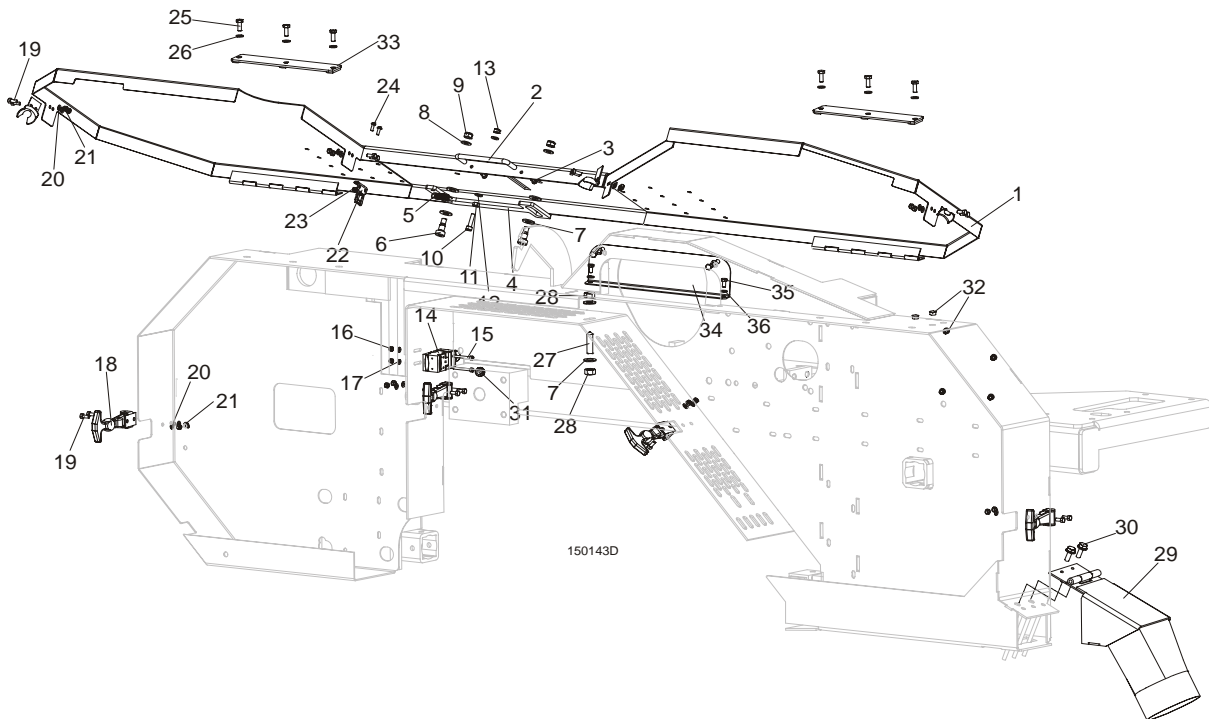

REF	DESCRIPTION (◆ Indicates Parts Available In Assemblies Only)	PART #	QTY.
	<b>COVER, LT15 FRONT COMPLETE</b>	098678	1
1	Cover Weldment, LT10/15/20 Blade Housing Painted	096776-1	1
2	Handle w/Bolt	P08065	1
3	Screw, #8-32x3/8 Self-tapping	F05015-8	2
4	Pawl, Locking Painted	090643-1	1
5	Spring, 1.6x12x38 Extension	092208	1
6	Bolt, 10/M8x12-12.9 ISO-7379 Shoulder	F81003-62	2
7	Washer, 10.5 Flat Zinc	F81055-1	4
8	Washer, 8.4 Flat Zinc	F81054-1	2
9	Nut, M8-8-B Hex Nylon Zinc Lock	F81032-2	2
10	Screw, M6x25-8.8 Hex Socket Head Cap Zinc	F81001-41	1
11	Nut, M6-8 Hex Zinc	F81031-1	1
12	Washer, 6.4 Flat Zinc	F81053-1	2
13	Nut, M6-8-B Hex Nylon Zinc Lock	F81031-2	1
14	<b>SWITCH, AZ17-11ZRK SAFETY</b>	094232	1
15	<b>SCREW, M4X35-8.8 HEX SOCKET HEAD CAP ZINC</b>	F81011-34	2
16	<b>NUT, M4-B HEX NYLON ZINC LOCK</b>	F81029-1	2

17	WASHER, 4.3 FLAT ZINC	F81051-2	2	
18	LATCH, FLEXIBLE DRAW	014829	4	
19	BOLT, M5X12-5.8 HEX HEAD FULL THREAD ZINC	F81000-5	8	
20	WASHER, 5.3 FLAT ZINC	F81052-1	8	
21	NUT, M5-8 DIN 985 ZINC-PLATED	F81030-2	8	
22	KEY, A217/170-B5 SAFETY SWITCH	094422	1	
23	NUT, M4-B HEX NYLON ZINC LOCK	F81029-1	2	
24	SCREW, M4X12-5.8-B CROSS RECESSED PAN HEAD ZINC	F81011-43	2	
25	BOLT, M6X16 8.8 HEX HEAD FULL THREAD ZINC	F81001-15	6	
26	WASHER, 6.4 FLAT ZINC	F81053-1	6	
27	SCREW, M10X40-45H HEX SOCKET SET CONE POINT ZINC	F81003-61	1	
28	NUT, M10-8-B HEX ZINC	F81033-3	2	
29	CHUTE, LT10/15/20 SAWDUST	100903-1	1	
30	BOLT, M8X16-8.8-B HEX HEAD FULL THREAD ZINC	F81002-20	2	
31	GROMMET, 22mm DIA. RUBBER	087400	1	
32	PLUG, SR1086-9,5	096846	6	
33	PLATE, COVER MOUNT	086701-1	2	
34	COVER, SAW HEAD MOUNT	096788-1	1	
35	BOLT, M6X12MM HEX HEAD ZINC	F81001-7	4	
36	WASHER, M6 FLAT ZINC	F81053-1	4	

4.2 Water Lube Assembly

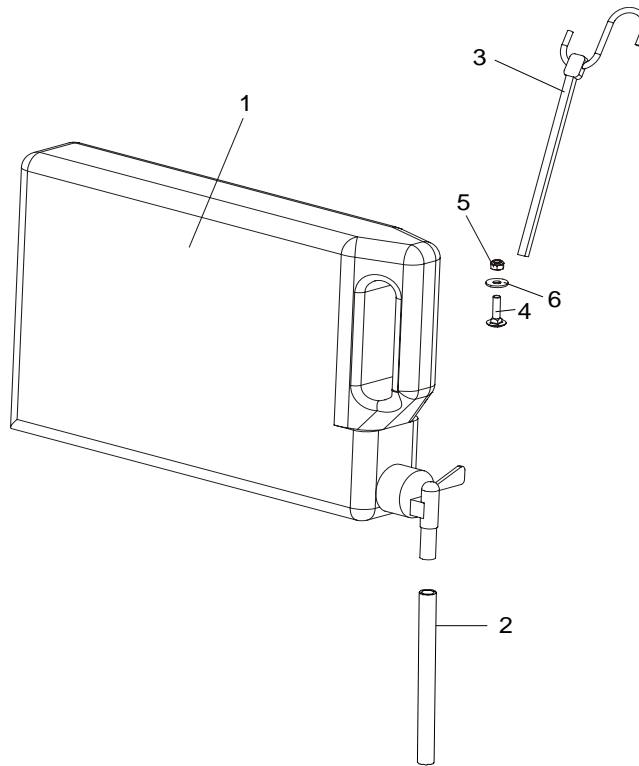

REF	DESCRIPTION (◆ Indicates Parts Available In Assemblies Only)	Part #	Qty.
1	Bottle, 5-liter Water	049119	1
2	Tube, 3/8" I.D. Water Lube	R01885	1,7 m
3	Strap, 24" Rubber w/Hook	P11258	2
4	Bolt, M6x25-8.8 Mushroom Head Square Neck Zinc	F81001-20	1
5	Nut, M6-8-B Hex Nylon Zinc Lock	F81031-2	1
6	Washer, 6.5 Special Flat Zinc	F81053-11	1

### 4.3 Decals, HR110

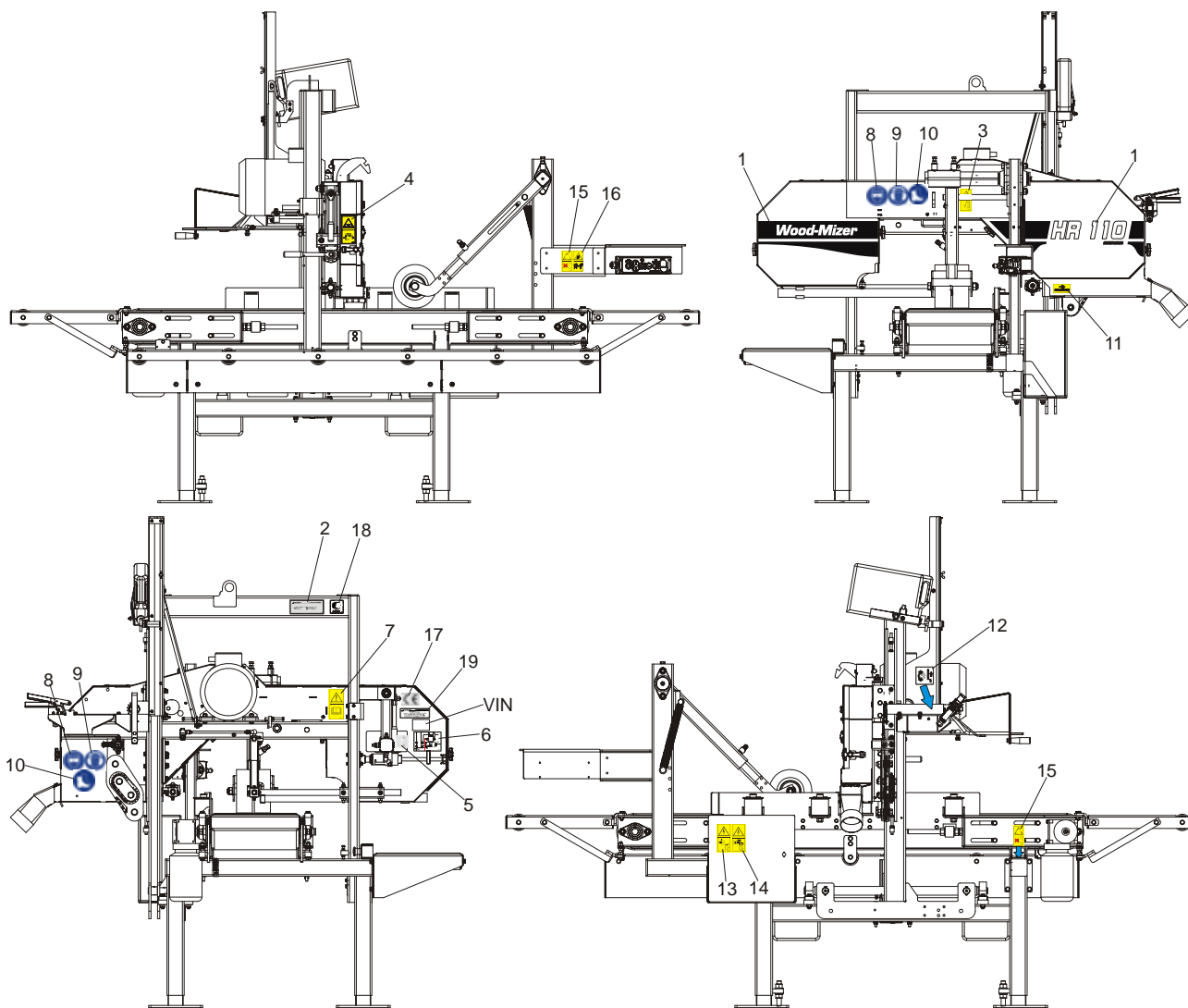

REF	DESCRIPTION (◆ Indicates Parts Available In Assemblies Only)	Part #	Qty.
	<b>PICTOGRAPHIC DECAL KIT, HR110</b>	504240	1
1	DECAL, HR110 SAWMILL NAME	504239	1
2	DECAL, EUROPEAN HEADQUARTERS ADDRESS	015841	1
3	DECAL, SAWMILL COVERS CAUTION	099220	1
4	DECAL, BLADE TENSION (PICTOGRAM)	099219	1
5	DECAL, BLADE ALIGNMENT	P11789	1
6	DECAL, BLADE TENSION INDICATOR ADJUSTMENT	092597	1
7	DECAL, READ OPERATOR'S MANUAL (PICTOGRAM)	096317	1
8	DECAL, EYE PROTECTION WARNING (PICTOGRAM)	S12004G	2
9	DECAL, EAR PROTECTION WARNING (PICTOGRAM)	S12005G	2
10	DECAL, USE SAFETY BOOTS (PICTOGRAM)	501465	2
11	DECAL, BLADE MOVEMENT DIRECTION (PICTOGRAM)	096321	1

<b>12</b>	DECAL, POWER FEED SYSTEM ENGAGEMENT (PICTOGRAM)	099226	1	
<b>13</b>	DECAL, HIGH VOLTAGE INSIDE THE ELECTRIC BOX (PICTOGRAM)	096316	1	
<b>14</b>	DECAL, REMOVE THE PLUG BEFORE OPENING THE BOX (PICTOGRAM)	096319	1	
<b>15</b>	DECAL, GEAR CAUTION	099540	2	
<b>16</b>	DECAL, KEEP A SAFE DISTANCE AWAY	099221	1	
<b>17</b>	<b>DECAL, CE CERTIFIED SAWMILL (SMALL)</b>	P85070	1	
<b>18</b>	<b>DECAL, RUSSIAN SAFETY CERTIFICATION</b>	099401	1	
<b>19</b>	<b>DECAL, INTERNATIONAL SAWMILL NAME</b>	501466	1	

## 4.4 Control Panel, HR110

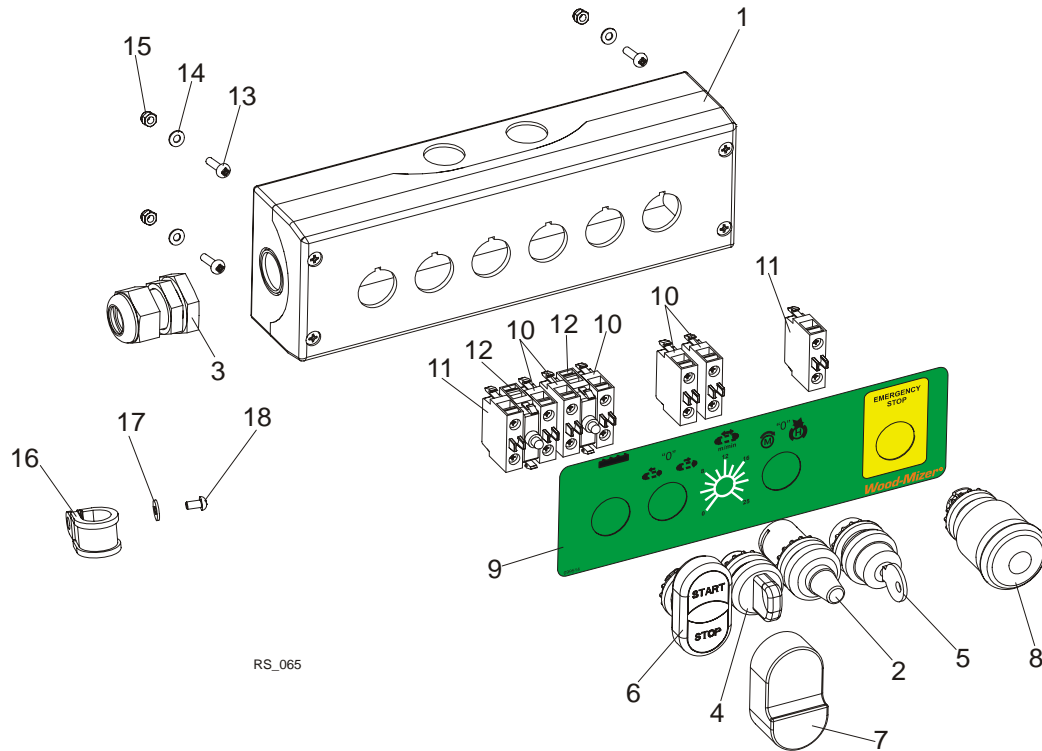

RS\_065

REF	DESCRIPTION (◆ Indicates Parts Available In Assemblies Only)	PART #	QTY.
	<b>CONTROL BOX, RESAW &amp; HR</b>	093458	1
1	Box, M22-I6 (216540) Control	093750	1
2	Potentiometer, M22-R1K (229489)	093749	1
3	Connector, DP 16/H	F81096-7	1
4	Switch, M22 - 3 Position	091360	1
5	Operator, M22-WRS3 Key Switch	095001	1
6	Operator, M22-DDI-GR-GB1/GB0 Switch	094997	1
7	Membrane M22-T-DD	090462	1
8	Emergency Switch, M22 - PVT	099599	1
9	Decal, HR Control Box	099514	1
10	Contact Element, M22-KC10	094314	5
11	Contact Element, M22-KC01	094998	2
12	LED Element, M22-LEDC-W	094999	2
13	<b>SCREW, M4X16 5,8-B FE/ZN5 PN-M/82202</b>	F81011-42	4
14	<b>WASHER 4,3 FE/ZN5 PN-M/82005</b>	F81051-2	4
15	<b>NUT M4-B FE/ZN5 PN-M/82175</b>	F81029-1	4
16	<b>GUARD, WRAP-AROUND PAINTED</b>	F81087-2	7
17	<b>WASHER, 5.5 FLAT ZINC SPECIAL</b>	F81052-3	7
18	<b>SCREW, H M5X10 8.8 FE/ZN5 PN-M/82202</b>	F81000-13	7

4.5 Electric Box Decals

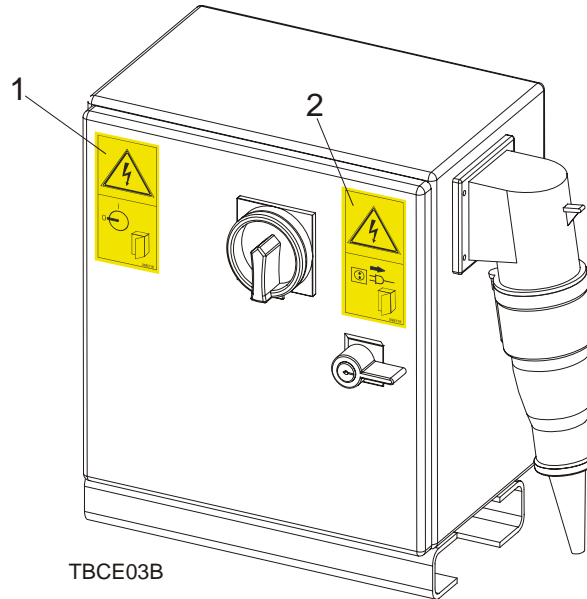

REF	DESCRIPTION (◆ Indicates Parts Available In Assemblies Only)	PART #	QTY.
	ELECTRIC BOX, HR115	503787	1
1	DECAL, HIGH VOLTAGE INSIDE THE ELECTRIC BOX (PICTOGRAM)	096316	1
2	DECAL, REMOVE THE PLUG BEFORE OPENING THE BOX (PICTOGRAM)	096319	1

## 4.6 Hold-Down Roller Assembly

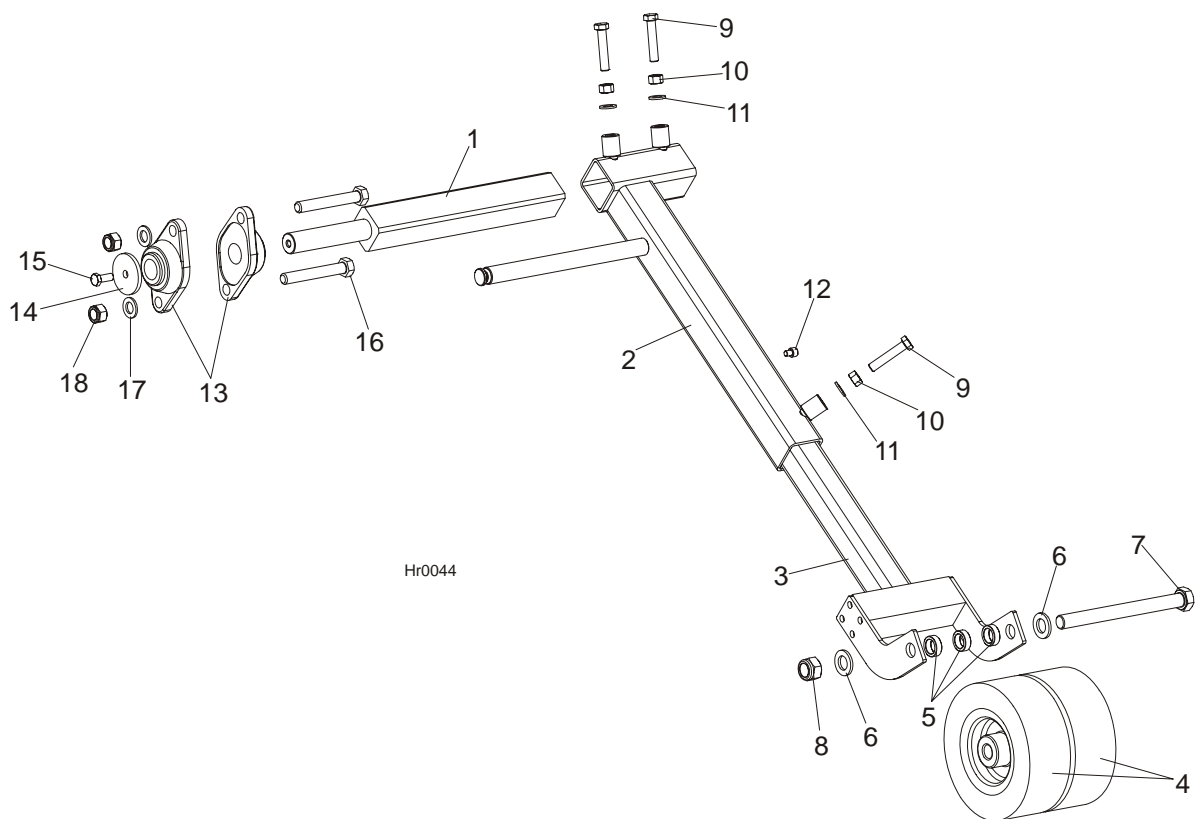

REF	DESCRIPTION (◆ Indicates Parts Available In Assemblies Only)	PART #	QTY.	
	<b>ARM, HR115 HOLD-DOWN ROLLER</b>	503951	1	
1	AXLE, HOLD-DOWN ROLLER	099428-1	1	
2	ARM, HR115 HOLD-DOWN ROLLER OUTSIDE	503953-1	1	
3	ARM WELDMENT, HR1115 HOLD-DOWN ROLLER INSIDE PAINTED	503955-1	1	
4	WHEEL, 200 60NN (SVS)HOLD-DOWN	099160	2	
5	BUSHING, 21x30x10 SPACER	099351-1	3	
6	WASHER, M20 FLAT ZINC	F81059-2	2	
7	BOLT, M20X220-8.8 FE/ZN5 PN-85/M-82101	F81007-4	1	
8	NUT, M20-6 HEX	F81037-2	1	
9	BOLT, M12X60-8.8 HEX HEAD FULL THREAD ZINC	F81004-51	3	
10	NUT, M12-8-B ZINC HEX	F81034-1	3	
11	WASHER, 13 FLAT ZINC	F81056-1	3	
12	SCREW, M8X10-8.8-FE/ZN5 HEX SOCKET HEAD	F81002-32	1	
13	BEARING, UCFL 206 CX BALL	090851	2	
14	WASHER, IDLE BLADE WHEEL RETAINING	088957-1	1	
15	BOLT, M10-1.5X25MM HH GR8.8	F81003-11	1	
16	BOLT, M16X110-8.8-FE/ZN5 PN-M/82101	F81006-24	2	
17	WASHER, 17 FLAT ZINC	F81058-1	2	
18	NUT, M16, HEX, NYLON ZINC LOCK	F81036-2	2	



### 4.7 Infeed, Outfeed & Return Tables

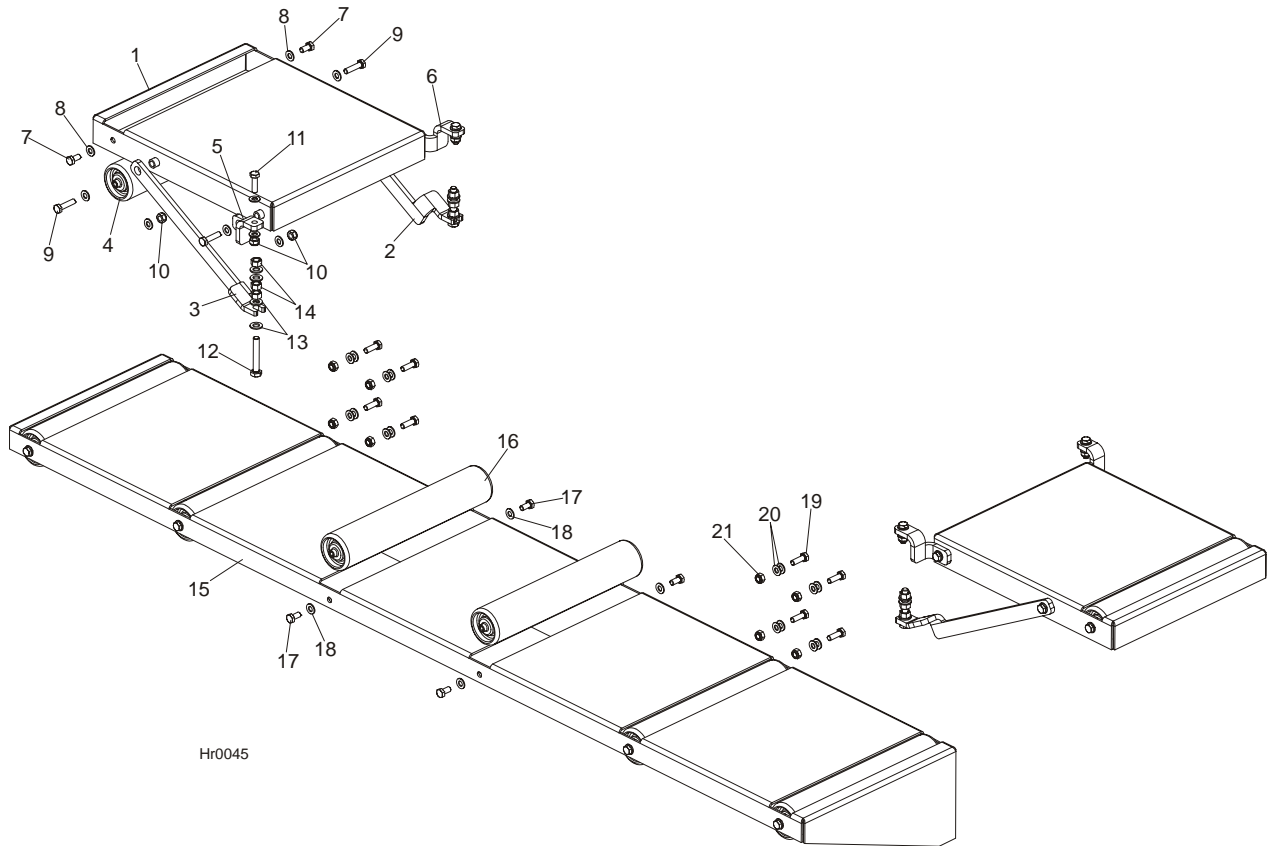

REF	DESCRIPTION (◆ Indicates Parts Available In Assemblies Only)	PART #	QTY.
	<b>TABLE, HR115 SHORT COMPLETE</b>	503962	2
1	TABLE, HR115 SHORT	503961-1	1
2	SUPPORT, HR115 SHORT TABLE LEFT	503958-1	1
3	SUPPORT, HR115 SHORT TABLE RIGHT	503959-1	1
4	ROLLER, 76x400 W/M10 INTERNAL THREAD	093787	1
5	BRACKET, HR130 SHORT TABLE LEFT	503963-1	1
6	BRACKET, HR130 SHORT TABLE RIGHT	503964-1	1
7	BOLT, M10x20MM,HEX HEAD,GR 5.8 ZINC	F81003-1	2
8	WASHER, 10.5 FLAT ZINC	F81055-1	14
9	BOLT, M10 X 40-8.8 Fe/Zn5, PN-M/82105	F81003-16	4
10	NUT, M10-8-B HEX NYLON ZINC LOCK	F81033-1	6
11	BOLT,M10X35-8.8 HEX HEAD FULL THREAD ZINC	F81003-17	2
12	BOLT, M12X75	F81004-10	2
13	WASHER, 13 FLAT ZINC	F81056-1	8
14	NUT, M12-8-B ZINC HEX	F81034-1	6
	<b>TABLE, HR130 LONG COMPLETE</b>	503966	1
15	TABLE, HR130 LONG	503991-1	1
16	ROLLER, 76x400 W/M10 INTERNAL THREAD	093787	6
17	BOLT, M10x20MM,HEX HEAD,GR 5.8 ZINC	F81003-1	12
18	WASHER, 10.5 FLAT ZINC	F81055-1	12

**5****SAW HEAD & FEED TRACK***Infeed, Outfeed & Return Tables*

---

19	BOLT, M10X30-5.8 HEX HEAD FULL THREAD ZINC	F81003-2	8	
20	WASHER, 10.5 FLAT ZINC	F81055-1	16	
21	NUT, M10-8-B HEX NYLON ZINC LOCK	F81033-1	8	

4.8 Feed Track Assembly

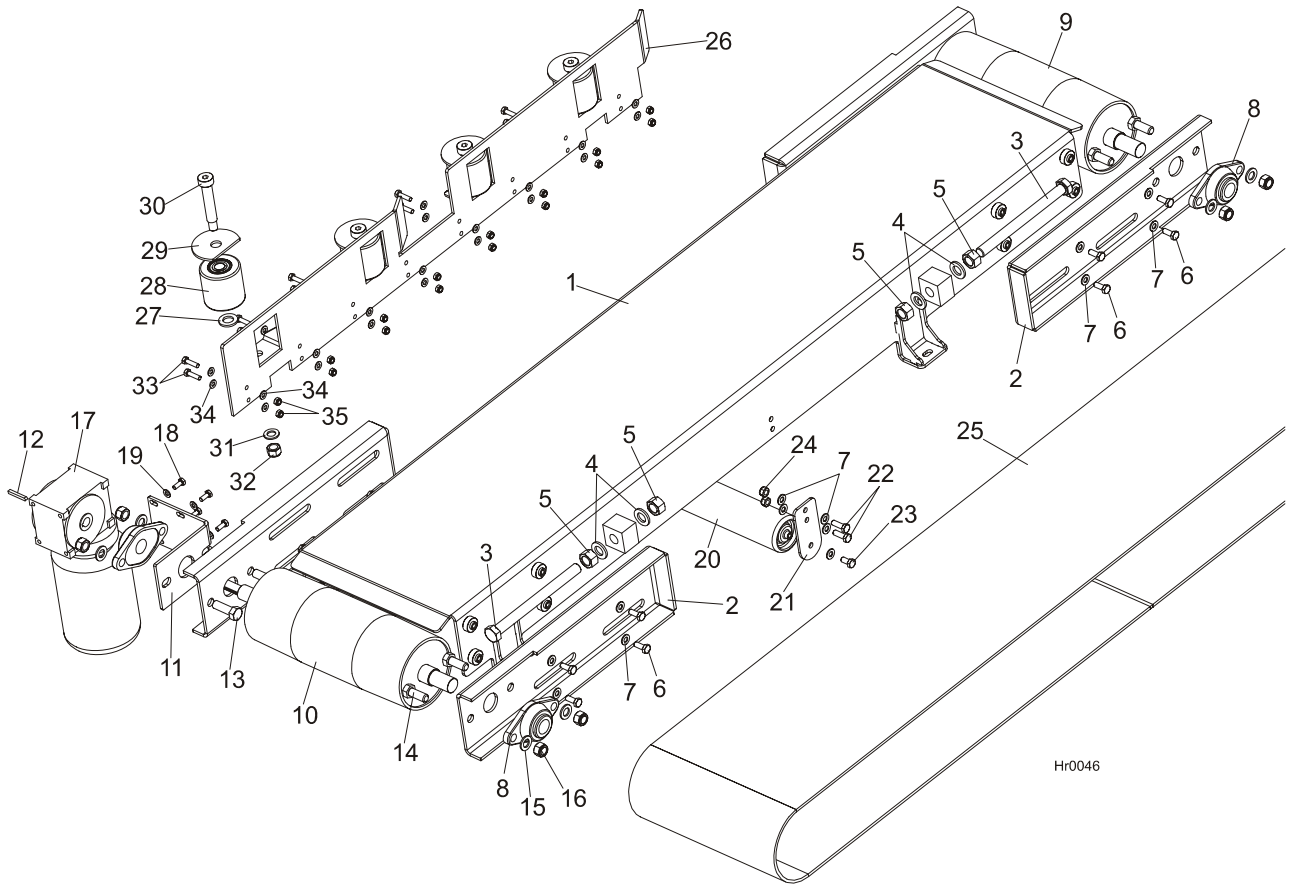

REF	DESCRIPTION (◆ Indicates Parts Available In Assemblies Only)	PART #	QTY.
	<b>TABLE, HR130 COMPLETE</b>	503780	1
1	TABLE, HR115	503775-1	1
2	BRACKET, HR300 PULLEY MOUNT PAINTED	094889-1	4
3	BOLT, M20X240-8.8 FE/ZN5 PN-85/M 82105	F81007-1	4
4	WASHER, 21 FLAT ZINC	F81059-2	8
5	NUT, M20-8 HEX ZINC	F81037-1	8
6	BOLT, M10X25-8.8-FE/ZN5	F81003-11	16
7	WASHER, 10.5 FLAT ZINC	F81055-1	24
8	BEARING, UCFL 206 CX BALL	090851	4
9	PULLEY, HR115 IDLE SIDE PAINTED	503776-1	1
10	PULLEY, HR115 DRIVE SIDE PAINTED	503781-1	1
11	BRACKET, HR300 GEAR BOX MOUNT PAINTED	094898-1	1
12	KEY, AB 6X6X45 PARALLEL	089229	1
13	BOLT, M16X50-8.8 HEX HEAD FULL THREAD ZINC	F81006-7	2
14	BOLT, M16X40-8.8 HEX HEAD FULL THREAD ZINC	F81006-13	6
15	WASHER, 17 FLAT ZINC	F81058-1	8

16	NUT, M16-8 HEX NYLON ZINC LOCK	F81036-2	8	
17	MOTOR & GEAR BOX, MRA-04/15.5/D4/STN 0.37KW 900RPM	094897	1	
18	BOLT, M8X20-5.8 HEX HEAD FULL THREAD ZINC	F81002-1	4	
19	WASHER, 8.4 FLAT ZINC	F81054-1	4	
20	ROLLER, 76x400 W/M10 INTERNAL THREAD	093787	1	
21	SUPPORT, HR115 ROLLER	503782-1	2	
22	BOLT, M10x30-5.8 HEX HEAD FULL THREAD ZINC	F81003-2	4	
23	BOLT, M10X20MM, HEX HEAD, GR 5.8 ZINC	F81003-1	2	
24	NUT, M10-8-B HEX NYLON ZINC LOCK	F81033-1	4	
25	TYPE, EP 250/2 3+0 GRIP B=380 L=4670	503956	1	
	COVERING FOR PULLEYS	R00100	? m	
	RIVET, P AL/FE 4X10 TUBULAR W/CORE	F81021-11	2	
	RUNNER, SIDE COMPLETE	503985	1	
26	RUNNER, HR130 SIDE	503984-1	1	
27	WASHER, 21 FLAT ZINC	F81059-2	4	
28	ROLLER, R-80-80 SIDE	099429	4	
29	COVER, SIDE ROLLER	503969-1	4	
30	BOLT, 20/M16X90 12.9 ISO7379 FITTED	F81006-30	4	
31	WASHER, 17 FLAT ZINC	F81058-1	4	
32	NUT, M16, HEX, NYLON ZINC LOCK	F81036-2	4	
33	BOLT, M8X30MM, HH, GR 5.8, FULL THRD, ZINC	F81002-2	16	
34	WASHER, 8.4 FLAT ZINC	F81054-1	32	
35	NUT, M8-8-B HEX NYLON ZINC LOCK	F81032-2	16	

## SECTION 5 UP/DOWN SYSTEM

### 5.1 Up/Down Crank Assembly

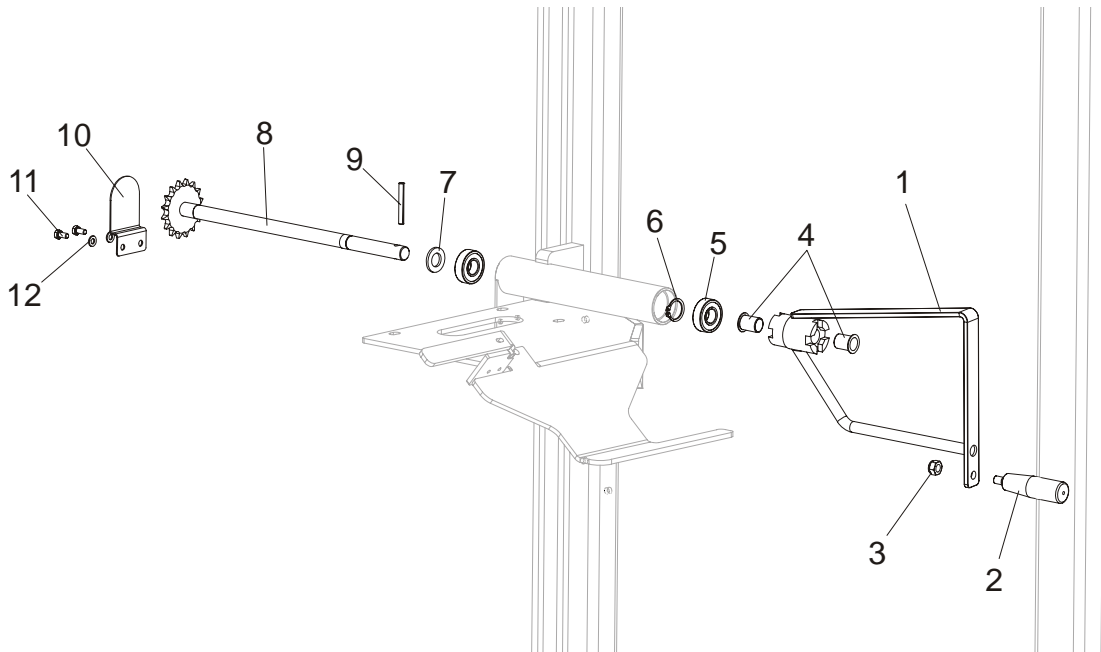

REF	DESCRIPTION (◆ Indicates Parts Available In Assemblies Only)	Part #	Qty.
	<b>FEED CRANK COMPLETE</b>	502967	1
1	CRANK, WELDMENT LT105	086120-1	1
2	KNOB, 12992M10 PLASTIC CRANK HANDLE	086338	1
3	NUT, M10-8-B HEX NYLON ZINC LOCK	F81033-1	1
4	BUSHING, GFM-1719-25	094142	2
5	<b>BEARING, 6203-2RS</b>	086114	2
6	<b>RING, Z 17 OUTSIDE RETAINING</b>	F81090-21	1
7	<b>WASHER, 17 FLAT ZINC</b>	F81058-1	1
8	<b>SHAFT W/SPROCKET LT10</b>	097242-1	1
9	<b>PIN, 6X50 ZINC ROLL</b>	F81045-1	1
10	<b>GUARD, UPPER LT10 SAW HEAD SPROCKET</b>	092567-1	1
11	<b>BOLT, M6X12-8.8 HEX HEAD FULL THREAD ZINC</b>	F81001-7	2
12	<b>WASHER, 6.4 FLAT ZINC</b>	F81053-1	2

**5.2 Up/Down Drive Sprocket Assembly**

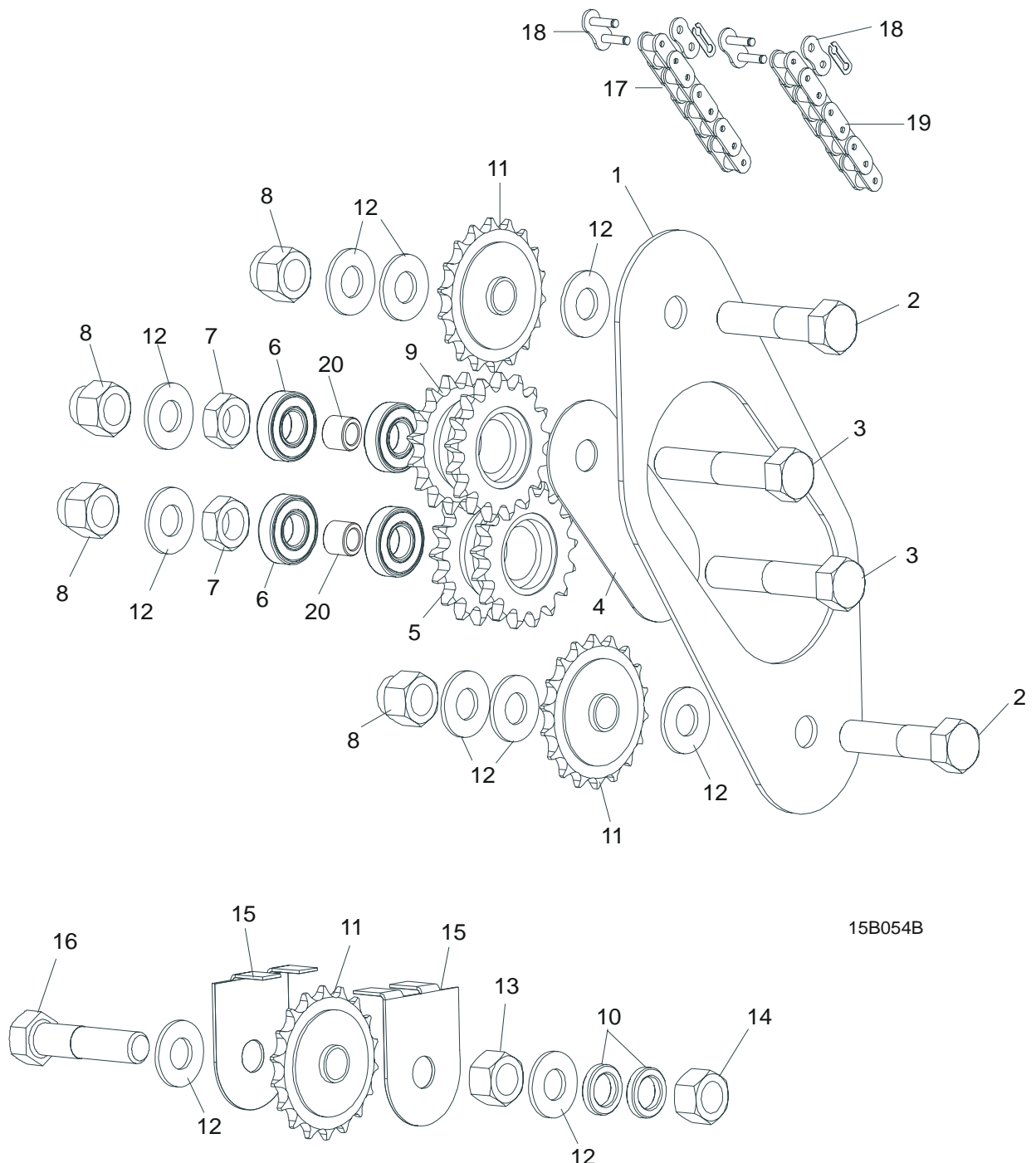

REF	DESCRIPTION (◆ Indicates Parts Available In Assemblies Only)	Part #	Qty.
1	GUARD, UP/DOWN CHAIN INTERNAL LT10	014907	1
2	BOLT, M16X65-8.8-B HEX HEAD FULL THREAD ZINC	F81006-1	2
3	BOLT, M16X80 8.8-B HEX HEAD FULL THREAD ZINC	F81006-11	2
4	PLATE, UP/DOWN DRIVE SPROCKET MOUNT PTD	087104-1	1

5	SPROCKET DUAL 17/17 PTD	086812-1	1	
6	BEARING, R-10	P04156	4	
7	NUT, M16 HEX THIN ZINC	F81036-4	2	
8	NUT, M16-8 HEX NYLON ZINC LOCK	F81036-2	4	
9	SPROCKET DUAL 16/17 PTD	086813-1	1	
10	WASHER, 41/64" X 1" X 3/16 SPACER	S12480	3	
11	SPROCKET, 17T G1#40-41 5/8" ID	P04333	3	
12	WASHER 17 FLAT ZINC	F81058-1	12	
13	NUT M16-5.8 HEX ZINC	F81036-1	1	
14	NUT, M16-8 HEX NYLON ZINC LOCK	F81036-2	1	
15	GUARD,LT10 UP/DOWN CHAIN SPROCKET	092566-1	2	
16	BOLT, M16X75-8.8-B HEX HEAD FULL THREAD ZINC	F81006-10	1	
17	CHAIN, #40 X 111 1/2"	014831	1	
18	LINK, #40 MASTER	P04200	2	
19	CHAIN, #40 X 15 1/2"	P12496	1	
20	BUSHING - ZINC	095938-1	2	

5.3 Slide Pads and Blade Height Scale Indicator

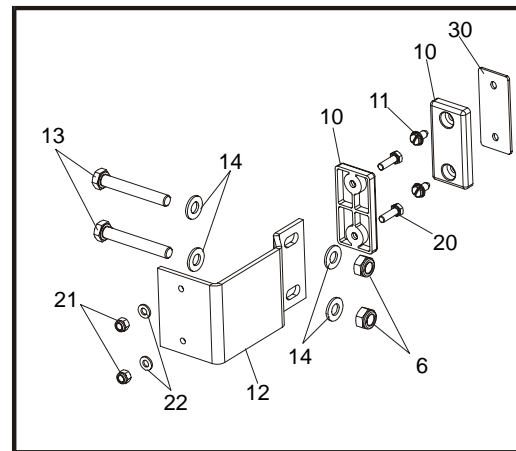
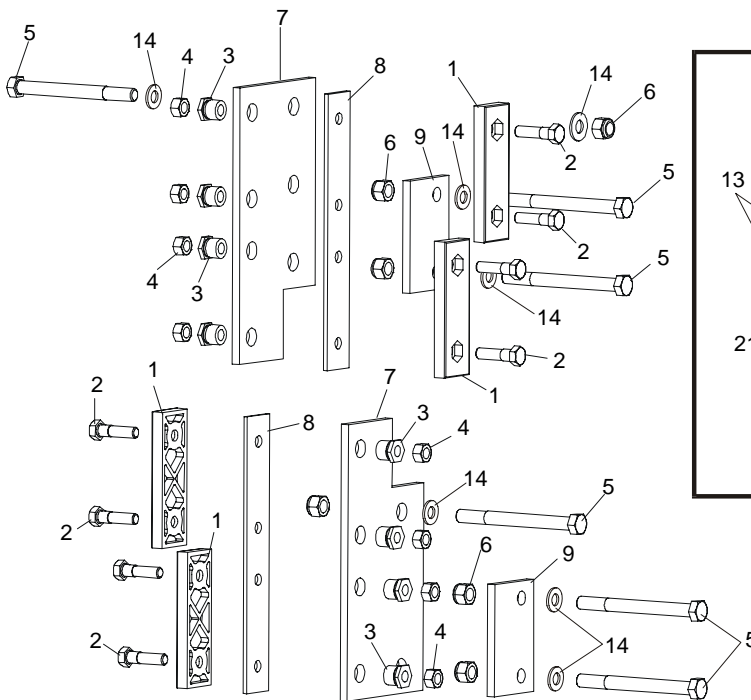
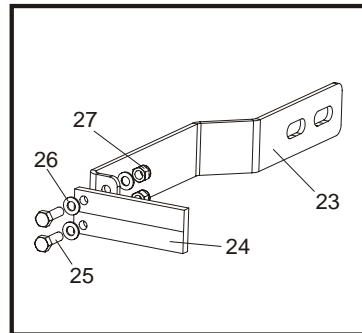
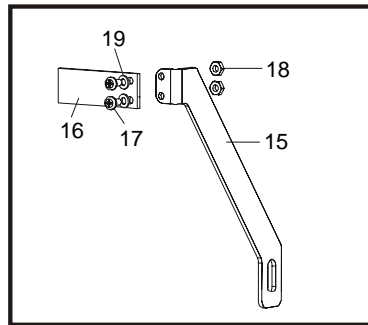

10\_041B

REF	DESCRIPTION (◆ Indicates Parts Available In Assemblies Only)	Part #	Qty.
1	PADS, UP/DOWN SLIDE	M04096	4
2	BOLT, M8X35 -8.8 HEX HEAD FULL THREAD ZINC	F81002-13	8
3	NUT, LT10 SLIDE PAD ADJUSTMENT ZINC-PLATED	086683-1	8
4	NUT, M8-8-B HEX NYLON ZINC LOCK	F81032-2	8
5	BOLT, M10X110 8.8 HEX HEAD ZINC	F81003-43	6
6	NUT, M10-8-B HEX NYLON ZINC LOCK	F81033-1	8
7	PLATE, LT10 SLIDE PAD MOUNT	086682-1	2
8	BACKING, MAST SLIDE PADS	014898-1	2
9	PLATE, SHORT SLIDE PAD MOUNT	085978-1	2
10	PAD, CATERPILLAR TRACK	P13576	2



11	BOLT, 1/4-20 X 1/2"SELF TAP HEX HEAD	F05015-1	2	
12	BRACKET, LT10MAST GUIDE IDLE SIDE PAINTED	087192-1	1	
13	BOLT, M10X70-8.8 HEX HEAD FULL THREAD ZINC	F81003-20	2	
14	WASHER, 10.5 FLAT ZINC	F81055-1	11	
15	BRACKET, LT10 BLADE HEIGHT SCALE MOUNT	092568-1	1	
16	INDICATOR, BLADE HEIGHT SCALE	094821	1	
17	BOLT, M4X16 5.8 HEX HEAD FULL THREAD ZINC	F81011-6	2	
18	NUT, M4-B HEX NYLON ZINC LOCK	F81029-1	2	
19	WASHER, 4.3-FLAT ZINC	F81051-2	2	
	DECAL, METRIC SCALE LT10	086142		
20	BOLT, M6X20-8.8 HEX HEAD FULL THREAD ZINC	F81001-2	2	
21	NUT, M6-8-B HEX NYLON ZINC LOCK	F81031-2	2	
22	WASHER, 6.4 FLAT ZINC	F81053-1	2	
	INDICATOR, BLADE HEIGHT SCALE COMPLETE (OPTION)	<b>097569</b>		
23	Base, Blade Height Indicator Painted	097568-1	1	
24	Indicator, Blade Height	094821	1	
25	Bolt, M5x16 -8.8 Hex Head Full Thread Zinc	F81000-20	2	
26	Washer, 5.3 Flat Zinc	F81052-1	4	
27	Nut, M5-8-Fe/Zn5 DIN 985	F81030-2	2	
28	Bolt, M8x12-8.8 Hex Head Full Thread Zinc	F81002-6	2	
29	Washer, 8,4 Flat Zinc	F81054-1	2	
30	WASHER, SLIDE PAD	101324-1	1	

### 5.4 Blade Height Scale (Optional)

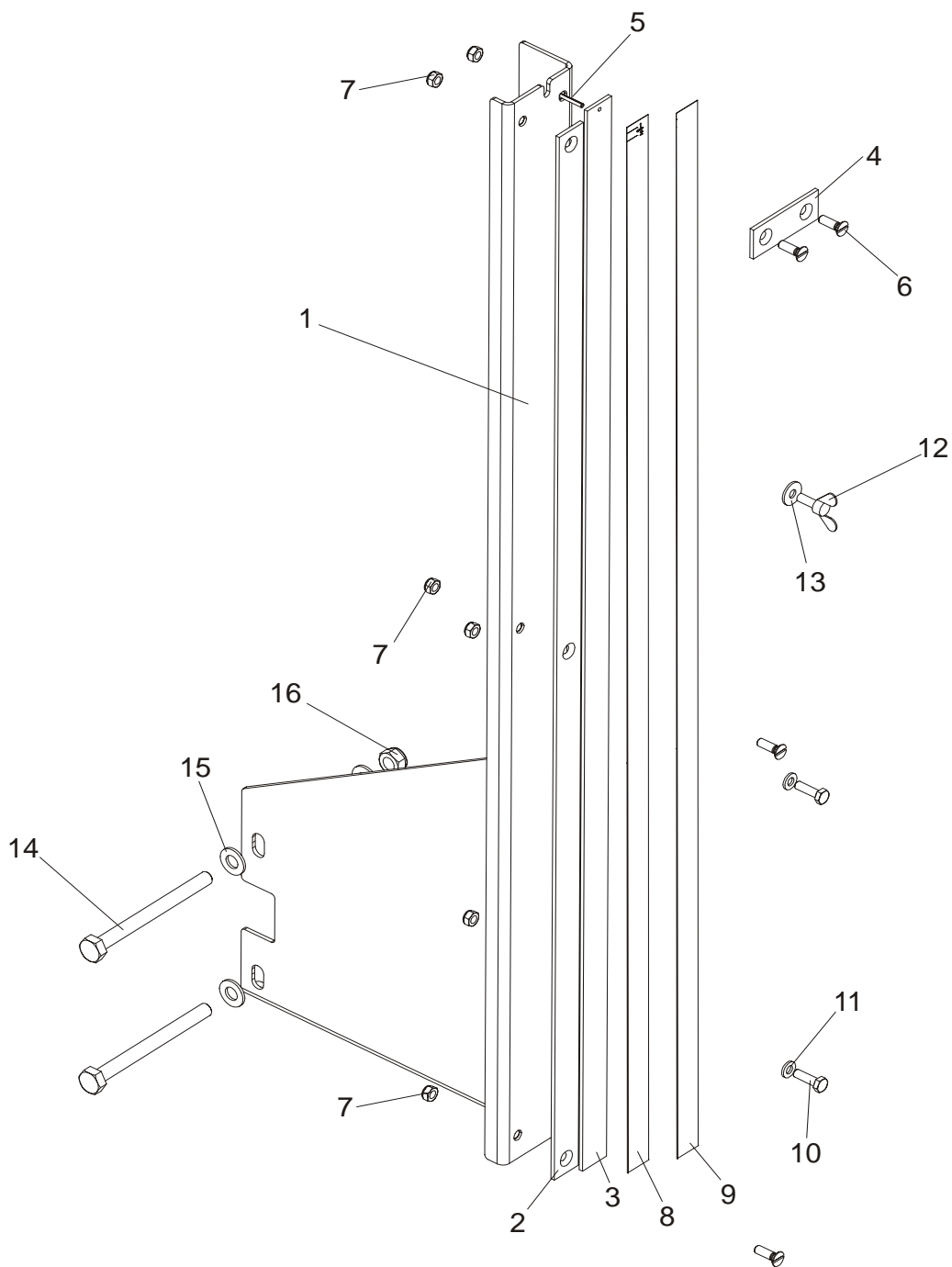

REF	DESCRIPTION (◆ Indicates Parts Available In Assemblies Only)	PART #	QTY.
	<b>SCALE , BLADE HEIGHT COMPLETE</b>	095964	1
1	Bcracket, Blade Height Scale LT10 Painted	095965-1	1
2	Plate, Decal Mount	092750	1
3	Plate, Inch Decal Mount	093133	1

<b>4</b>	Bar, Scale Mount	093134	1	
<b>5</b>	Pin, 3x20 Zinc Roll	F81044-5	1	
<b>6</b>	Screw, M6x20 Slotted Countersunk Head Zinc	F81001-31	3	
<b>7</b>	Nut, Hex Nylon Zinc Lock	F81031-2	6	
<b>8</b>	Decal, LT10 0-80CM Centimeter Scale	091239	1	
<b>9</b>	Decal, 16-40mm Metric Decal, 45-63mm Metric	P12040-1 P12040-2	1	
<b>10</b>	Bolt, M6x20-8.8 Hex Head Full Thread Zinc	F81001-2	2	
<b>11</b>	Washer, 6.4 Flat Zinc	F81053-1	2	
<b>12</b>	Screw, M6x16 BN276 DIN 316 Thumb	F81001-16	1	
<b>13</b>	Washer, 6.5 Special Flat Zinc	F81053-11	1	
<b>14</b>	Bolt, M10x115-8.8 Hex Head Zinc	F81003-19	2	
<b>15</b>	Washer, 10.5 Flat Zinc	F81055-1	4	
<b>16</b>	Nut, M10-8-B Hex Nylon Zinc Lock	F81033-1	2	