

# **Wood-Mizer®**

## **Replacement Parts Manual**

---

**HR110**

**rev.A3.00**

---



**Safety is our #1 concern!** Read and understand all safety information and instructions before operating, setting up or maintaining this machine.

*September 2010*

*Form #927*

<b>SECTION 1</b>	<b>GENERAL INFORMATION</b>	<b>1-1</b>
1.1	How To Use The Parts List .....	1-1
1.2	Sample Assembly .....	1-1
<b>SECTION 2</b>	<b>BLADE GUIDE ROLLERS &amp; ARM</b>	<b>2-1</b>
2.1	Blade Guide Assembly, Idle Side.....	2-1
2.2	Blade Guide Assembly, Drive Side.....	2-2
2.3	Blade Guide Roller Guards .....	2-3
<b>SECTION 3</b>	<b>BLADE WHEELS &amp; TENSIONER</b>	<b>3-1</b>
3.1	Blade Wheel Assembly, Drive Side .....	3-1
3.2	Blade Wheel Assembly, Idle Side .....	3-2
3.3	Blade Tensioner Assembly .....	3-4
3.4	Motor Assembly, HR110.....	3-6
3.5	Motor Assembly HR115.....	3-7
<b>SECTION 4</b>	<b>SAW HEAD &amp; FEED TRACK</b>	<b>4-1</b>
4.1	Blade Housing Cover .....	4-1
4.2	Water Lube Assembly .....	4-3
4.3	Decals, HR110.....	4-4
4.4	Control Panel, HR110 .....	4-6
4.5	Electric Box Decals .....	4-8
4.6	Hold-Down Roller Front .....	4-9
4.7	Hold-Down Roller Rear .....	4-11
4.8	Infeed, Outfeed & Return Tables .....	4-12
4.9	Feed Track Assembly .....	4-13
4.10	Table, Idle Roller.....	4-15
<b>SECTION 5</b>	<b>UP/DOWN SYSTEM</b>	<b>5-1</b>
5.1	Up/Down Crank Assembly.....	5-1
5.2	Up/Down Drive Sprocket Assembly .....	5-2
5.3	Slide Pads And Blade Height Scale.....	5-4



# Getting Service

Wood-Mizer is committed to providing you with the latest technology, best quality and strongest customer service available on the market today. We continually evaluate our customers' needs to ensure we're meeting current wood-processing demands. Your comments and suggestions are welcome.

### General Contact Information

From Europe call your local distributor or our European Headquarters and Manufacturing Facility in Kolo, Nagórna 114 St, Poland at **+48-63-2626000**. From the continental U.S., call our U.S. Headquarter 8180 West 10th St.Indianapolis, IN 46214, toll-free at **1-800-525-8100**. Ask to speak with a Customer Service Representative. Please have your machine identification number and your customer number ready when you call. The Service Representative can help you with questions about the operation and maintenance of your machine. He also can schedule you for a service call.

### Office Hours:

Country	Monday - Friday	Saturday	Sunday
Poland	7 a.m.- 3 p.m.	Closed	Closed
US	8 a.m.- 5 p.m.	8 a.m.- 12 p.m	Closed

Please have your vehicle identification number and your customer number ready when you call.

Wood-Mizer will accept these methods of payment:

- Visa, Mastercard, or Discover
- COD
- Prepayment
- Net 15 (with approved credit)

Be aware that shipping and handling charges may apply. Handling charges are based on size and quantity of order.

Branches & Authorized Sales Centers

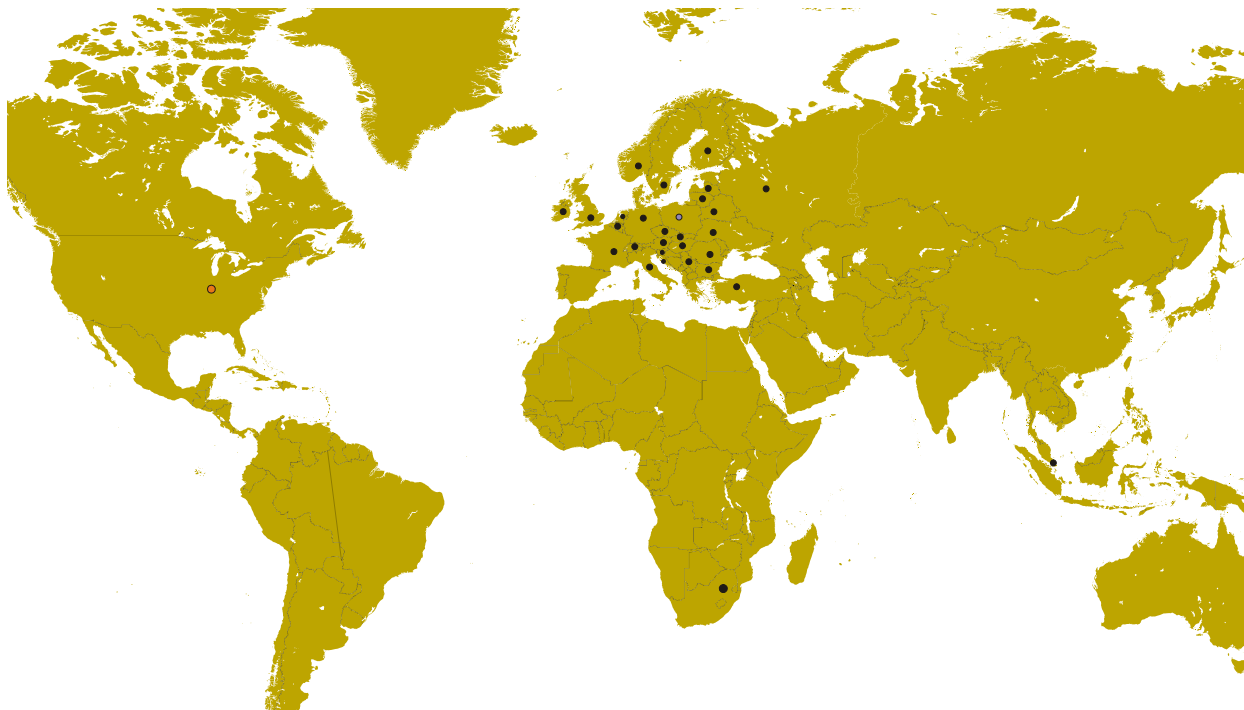

EUROPE		UNITED STATES
<p><b>European Headquarters</b>  <b>Wood-Mizer Industries Sp. z o.o.</b>                      Nagórna 114, 62-600 Kolo, Poland                      Tel.: +48-63-26-26-000                      Fax: +48-63-27-22-327                      www.woodmizer.eu</p>		<p><b>World Headquarters</b>  <b>Wood-Mizer LLC</b>                      8180 West 10th Street                      Indianapolis, Indiana 46214-2400,                      USA                      Tel.: +1-317-271-1542                      Fax: +1-317-273-1011                      www.woodmizer.com</p>
<p><b>BELARUS</b>  <b>MOST-GRUPP</b>                      Siemashko 15, k.3                      Minsk 2200116                      Tel.: +375-17-270-90-08                      Fax: +375-17-270-90-08                      GSM: +375-29-649-90-80                      e-mail: <a href="mailto:most-by@mail.ru">most-by@mail.ru</a></p>	<p><b>SWITZERLAND Bruno Steiner</b>                      Striegelgasse 2                      CH-6214 Schenkon                      Tel.: +41-41-921-13-01                      Fax: +41-41-922-18-87                      e-mail: <a href="mailto:info@mobilsaegen.ch">info@mobilsaegen.ch</a></p>	<p><b>RUSSIA Dariusz Mikołajewski</b>  <b>OOO WOOD-MIZER INDUSTRIES</b>                      141031, Moscow                      Reg., Mytishenski raj., pos. Veshki,                      Zavodskaja str., 3B                      Tel.Fax: +7(495) 788-72-35                      Tel.Fax: +7(495) 641-51-60                      e-mail: <a href="mailto:dariuszm@woodmizer-moscow.ru">dariuszm@woodmizer-moscow.ru</a></p>
<p><b>BULGARIA Kalin Simeonov</b>  <b>Ecotechproduct</b>                      38 Star Lozenski pat str.                      Sofia 1186                      Tel.: +359-2-462-7035                      Tel.: +359-2-963-1656                      Tel./Fax                      : +359-2-979-1710  <b>Kalin Simeonov</b>                      GSM: +3592-963-2559                      e-mail: <a href="mailto:office@ecotechproduct.com">office@ecotechproduct.com</a></p>	<p><b>HUNGARY Wiktor Turoczy</b>  <b>Wood-Mizer Hungary K.F.T.</b>                      Szonyi Ut 67., 2921 Komárom                      Tel./Fax: +36-34-346-255                      e-mail: <a href="mailto:woodmizer@woodmizer.hu">woodmizer@woodmizer.hu</a></p>	<p><b>RUSSIA Far East Wladimir Glazczew</b>  <b>"WM Service"</b>                      Krasnoretchenskaya Str.111                      680006 Khabarovsk                      Tel./Fax: +7-914-541-1183                      e-mail: <a href="mailto:wms-khv@mail.ru">wms-khv@mail.ru</a></p>

<p><b>CROATIA Krešimir Pregernik Pregimex d.o.o.</b> S. Batušića 31, 10090 Zagreb Tel./Fax: +3851-38-94-668 <b>Krešimir Pregernik</b> GSM: +3851-98-207-106 e-mail: <a href="mailto:Kresimir.Pregernik@gmail.com">Kresimir.Pregernik@gmail.com</a></p>	<p><b>ITALY Pasquale Felice Wood-Mizer Italia Srl Cda. Capoiaccio SN</b> 86012 Cercemaggiore Campobasso Tel./Fax: +39-0874-798-357 GSM: +39-333-281-03-79 e-mail: <a href="mailto:wmitaliasrl@gmail.com">wmitaliasrl@gmail.com</a></p>	<p><b>SERBIA Dragan Markov Wood-Mizer Balkan d.o.o.</b> Svetosavska GA 3/3; P. Fah 25 23 300 Kikinda Tel./Fax: +381-230-25-754 Tel./Fax: +381-230-23-567 GSM: +381-63-568-658 e-mail: <a href="mailto:office@woodmizer.co.yu">office@woodmizer.co.yu</a></p>
<p><b>CZECH REPUBLIC Miroslaw Greill Wood-Mizer CZ s.r.o.</b> Osvaldova 91 339 01 Klatovy-Luby Tel./Fax: +420-376-312-220 Fax: +420-376-319-011 <b>Miroslaw Greill</b> GSM: +420-723-580-799 e-mail: <a href="mailto:greill@woodmizer.cz">greill@woodmizer.cz</a></p>		<p><b>SLOVAKIA Wiktor Turoczy Wood-Mizer Danubia s.r.o.</b> Hadovce 5, 94501 Komárno Tel.: +421-35-77-40-316 Fax: +421-35-7740-326 GSM: +421-905-930-972 e-mail: <a href="mailto:woodmizer@woodmizer.sk">woodmizer@woodmizer.sk</a></p>
<p><b>CZECH REPUBLIC Lubomir Kudlik Wood-Mizer Moravia</b> Sovadinova 6 69002 Breclav Tel./Fax: +420-519-322-443 <b>Lubomir Kudlik</b> GSM: +420-602-734-792 e-mail: <a href="mailto:info@wood-mizer.net">info@wood-mizer.net</a></p>	<p><b>LATVIA Vilmars Jansons OBERTS Ltd</b> Gaujas str. 32/2 LV-2167 Marupe, Rigas Raj. Tel.: +371-7-810-666 Fax: +371-7-810-655 <b>Vilmars Jansons</b> GSM: +371-92-06-966 <b>Andris Orols</b> GSM: +371-28-33-07-90 e-mail: <a href="mailto:andris@oberts.lv">andris@oberts.lv</a></p>	<p><b>TURKEY Er-Ka Ahsap Profil Kerestecilik San. ve Tic. Ltd. Sti.</b> Adana Keresteciler Sitesi 191 sk No.41 ADANA Tel.: +90-322-346-15-86 Fax: +90-322-345-17-07 GSM: +90-533-363-18-44 e-mail: <a href="mailto:info@erkaahsap.com.tr">info@erkaahsap.com.tr</a></p>
<p><b>FINLAND Howard Blackbourn Oy Falkberg Jordbruk Ab</b> Falkintie 220 25610 Ylonkyla Tel.: +358-2732-2253 Fax: +358-2732-2263 <b>Howard Blackbourn</b> GSM: +358-440-424-339 e-mail: <a href="mailto:falkberg@woodmizer.fi">falkberg@woodmizer.fi</a></p>	<p><b>LITHUANIA Andrius Zuzevicius UAB Singlis</b> Savanoriu pr. 187, 2053 Vilnius Tel.: +370-5-2-32-22-44 Fax: +370-5-2-64-84-15 GSM: +370-620-28-645 e-mail: <a href="mailto:andrius.z@singlis.lt">andrius.z@singlis.lt</a></p> <p><b>Dmitrij Gaiduk</b> GSM: +370-69-84-51-91 e-mail: <a href="mailto:dmitrijus.g@singlis.lt">dmitrijus.g@singlis.lt</a></p>	<p><b>UKRAINE Ivan Vinnicki MOST UKRAINA</b> bul. Myru 3, Bajkivtsi Ternoplskyj r-j Ternopolska oblast 47711 Ukraine Tel/Fax: +38 (0352) 52 37 74 GSM: +38 (067) 352 54 34 GSM: +38 (067) 674 50 68 E-mail: <a href="mailto:most-ukraina@ukr.net">most-ukraina@ukr.net</a></p>
<p><b>FRANCE Laurence Serrurier Wood-Mizer France</b> Zac du Prè Marechal Route de Fruges 62560 Fauquembergues Tel: +33-321-930-544 Fax: +33-321-930-990 GSM: +33-607-025-282 Mail: <a href="mailto:lserrurier@woodmizer.fr">lserrurier@woodmizer.fr</a></p>	<p><b>NORWAY Odd Edvoll Wood-Mizer Nordic AS</b> Vardelia 17, 2020 Skedsmokorset Tel.: +47-63-87-49-89 Fax: +47-63-87-37-66 GSM: +47-930-42-335 e-mail: <a href="mailto:odd.edvoll@woodmizer.no">odd.edvoll@woodmizer.no</a></p> <p>e-mail: <a href="mailto:firmapost@woodmizer.no">firmapost@woodmizer.no</a></p>	<p><b>UNITED KINGDOM &amp; IRELAND Wood-Mizer UK</b> Hopfield Barn Kenward Road, Yalding Kent ME18 6JP, UK Tel.: +44-1622-813-201 Fax: +44-1622-815-534 e-mail: <a href="mailto:info@woodmizer.co.uk">info@woodmizer.co.uk</a></p>
<p><b>SLOVENIA Jan Fale FAMTEH d.o.o.</b> Gacnikova pot 2, 2390 Ravne na Koroskem Tel.: +386-2-62-04-232 Fax: +386-2-62-04-231 <b>Jan Fale</b> GSM: +386-2-62-04-230 e-mail: <a href="mailto:jan.fale@famteh.si">jan.fale@famteh.si</a></p> <p><b>Matjaz Kolar</b> Tel.: +386-2-62-04-232 GSM: +386-31-775-999 e-mail: <a href="mailto:matjaz.kolar@famteh.si">matjaz.kolar@famteh.si</a></p>		

<p><b>GERMANY Klaus Longmuss</b>  <b>Wood-Mizer Sägewerke GmbH</b>  Dorfstraße 5, 29485 Schletau  Tel.: +49-5883-9880-10  Fax: +49-5883-9880-20  e-mail: <a href="mailto:info@woodmizer.de">info@woodmizer.de</a></p> <p><b>Klaus Longmuss</b>  Tel.: +49-5883-9880-12  GSM: +49-17-298-55-892  e-mail: <a href="mailto:KLongmuss@woodmizer.de">KLongmuss@woodmizer.de</a></p>	<p><b>Subagent:</b>  <b>SWEDEN Kjell Larsson</b>  <b>Mekwood AB</b>  Slingan 14, 812 41 Gästrike-Hammarby  Tel.: +46-290-515-65  <b>Kjell Larsson</b>  GSM: +46-706-797-965  e-mail: <a href="mailto:kjell.larsson@mekwood.se">kjell.larsson@mekwood.se</a></p>	<p><b>IRELAND</b>  <b>Wood-Mizer Ireland</b>  Stephen Brennan  Cum Lahardane Ballina County Mayo  Tel: +353 96 51345</p> <p>E-mail: <a href="mailto:brennanmill@ericom.net">brennanmill@ericom.net</a></p>
<p><b>Subagents:</b>  <b>DENMARK Brian Jensen</b>  Amborgvej 9, 7330 Brande- Fasterholt  Tel.: +45-971-88-265  Fax: +45-971-88-266  <b>Brian Jensen</b>  GSM: +45-23-49-5828  e-mail: <a href="mailto:Fasterholt-Savvaerk@Mail.Tele.dk">Fasterholt-Savvaerk@Mail.Tele.dk</a></p>	<p><b>ROMANIA Adrian Echert</b>  <b>SC WOOD-MIZER RO SRL</b>  TRANSILVANIEI Nr. 5  Sibiu, Cisnadia 555300  Tel./Fax: : +40-369-405-433  GSM: +40-745-707-323  e-mail: <a href="mailto:aeichert@woodmizer.ro">aeichert@woodmizer.ro</a></p>	<p>Regional Manager - Asia  Wood-Mizer Asia Pte Ltd.  James Wong  Tel: +65 81216910  Fax: +65 6283 8636  WWW: <a href="http://www.woodmizerasia.com">www.woodmizerasia.com</a>  E-mail: <a href="mailto:jwong@woodmizerasia.com">jwong@woodmizerasia.com</a></p>
<p><b>Netherlands Chris Dragt</b>  Lange Brink 77d,  7317 BD Apeldoorn  Tel.: +31-55312-1833  Fax: +31-55312-2042  e-mail: <a href="mailto:Info@dragtbosbouw.nl">Info@dragtbosbouw.nl</a></p>	<p><b>Subagent:</b>  <b>ROMANIA M. Echert</b>  <b>S.C. Echert Comprod s.r.l</b>  Str. Schitului Nr. 6, Apt.7 etajul-1  725 70 Vatra Dornei, Romania  Tel./Fax: +40-230-374-235  Tel. : +40-740-35-35-74</p>	<p>Regional Manager - Africa  Wood-Mizer Africa  Jean-Jacques Oelofse  UNIT 3, LEADER PARK, NO: 20 CHARIOT ROAD  STORMILL, EXT 5, Roodepoort,  Johannesburg  Tel: +27 011 473 1313  Fax: +27 011 473 2005  Jean-Jacques Oelofse E-mail:  <a href="mailto:jjoelofse@woodmizerafrika.com">jjoelofse@woodmizerafrika.com</a>  Jean-Jacques Oelofse  Skype: <a href="https://www.skype.com/people/jean.jacques.pierre.oelofse">jean.jacques.pierre.oelofse</a></p>

## SECTION 1 GENERAL INFORMATION

### 1.1 How To Use The Parts List

- Use the index above to locate the assembly that contains the part you need.
- Go to the appropriate section and locate the part in the illustration.
- Use the number pointing to the part to locate the correct part number and description in the table.
- Parts shown indented under another part are included with that part.
- Parts marked with a diamond (◆) are only available in the assembly listed above the part.

See the sample table below. Sample Part #A01111 includes part F02222-2 and subassembly A03333. Subassembly A03333 includes part S04444-4 and subassembly K05555. The diamond (◆) indicates that S04444-4 is not available except in subassembly A03333. Subassembly K05555 includes parts M06666 and F07777-77. The diamond (◆) indicates M06666 is not available except in subassembly K05555.

<b>1.2 Sample Assembly</b>				
REF	DESCRIPTION (◆ Indicates Parts Available In Assemblies Only)	PART #	QTY.	
	Sample Assembly, Complete (Includes All Indented Parts Below)	A01111	1	
1	Sample Part	F02222-22	1	
	Sample Subassembly (Includes All Indented Parts Below)	A03333	1	
2	Sample Part (◆ Indicates Part Is Only Available With A03333)	S04444-4	1	◆
	Sample Subassembly (Includes All Indented Parts Below)	K05555	1	
3	Sample Part (◆ Indicates Part Is Only Available With K05555)	M06666	2	◆
4	Sample Part	F07777-77	1	

#### **To Order Parts:**

- From Europe call our European Headquarters and Manufacturing Facility in Kolo, Poland at **+48-63-2626000**. From the continental U.S., call our toll-free Parts hotline at **1-800-525-8100**. Have your customer number, vehicle identification number, and part numbers ready when you call. From other international locations, contact the Wood-Mizer distributor in your area for parts.

#### **Office Hours:**

Country	Monday - Friday	Saturday	Sunday
Poland	7-15	Closed	Closed
US	8 a.m.- 5 a.m.	8 a.m.- 12 p.m.	Closed



**CAUTION!** It is strongly recommended that only original spare parts be used.

## SECTION 2 BLADE GUIDE ROLLERS & ARM

### 2.1 Blade Guide Assembly, Idle Side

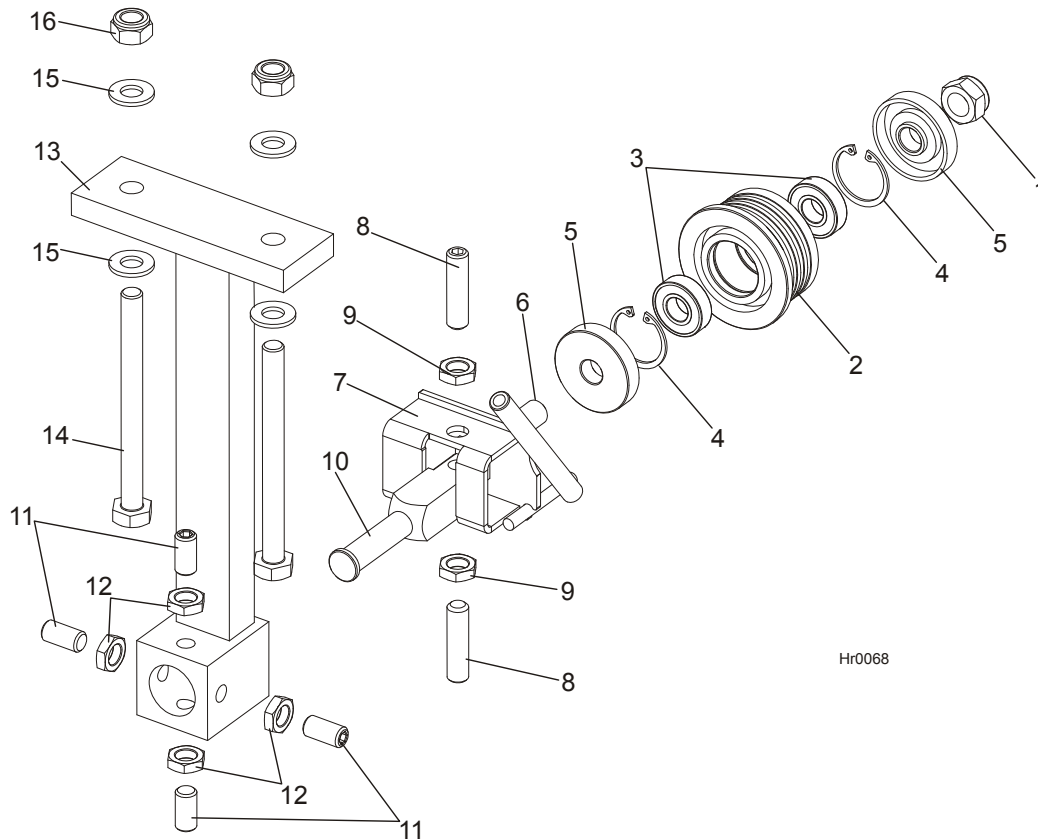

REF	DESCRIPTION (◆ Indicates Parts Available In Assemblies Only)	PART #	QTY.	
	<b>BLADE GUIDE ROLLER, HR115 INVERSION</b>	504863	1	
	BLADE GUIDE ASSEMBLY, IDLE SIDE	505613	1	
	Roller, Blade Guide Complete Standard	087887	1	
1	Nut, M12-8 Hex Nylon Zinc Lock	F81034-2	1	
2	Roller, Blade Guide Narrow	087889	1	◆
3	Bearing, 6001 2RSR FAG	087893	2	
4	Ring, W28 Inside Retaining	F81090-9	1	
5	Washer, Zinc-plated Spacer	087891-1	2	
6	Shaft, Blade Guide Roller Zinc-plated	087763-1	1	
7	Bracket Weldment, Idle Side Blade Guide Painted	094681-1	1	
8	Screw, M10x1x40 DIN 913 A2-70 Set Stainless Steel	F81015-2	2	
9	Nut, M10x1-04-ST-A2 ISO 8675 Thin	F81033-10	2	
10	Shaft, Zinc-plated Blade Guide Mount	088255-1	1	
11	SCREW, M10X1X20 DIN 913 SET STAINLESS STEEL	F81015-1	4	
12	NUT, M10x1-04-ST-A2 ISO 8675 THIN	F81033-10	4	
13	BRACKET, HR115 BLADE GUIGE INVERSION	504860-1	1	
14	BOLT, M10 X 115-8.8 Fe/Zn5, PN-M/82101	F81003-19	2	
15	WASHER, 10.5 FLAT ZINC	F81055-1	4	
16	NUT, M10-8-B HEX NYLON ZINC LOCK	F81033-1	2	



## 2.2 Blade Guide Assembly, Drive Side

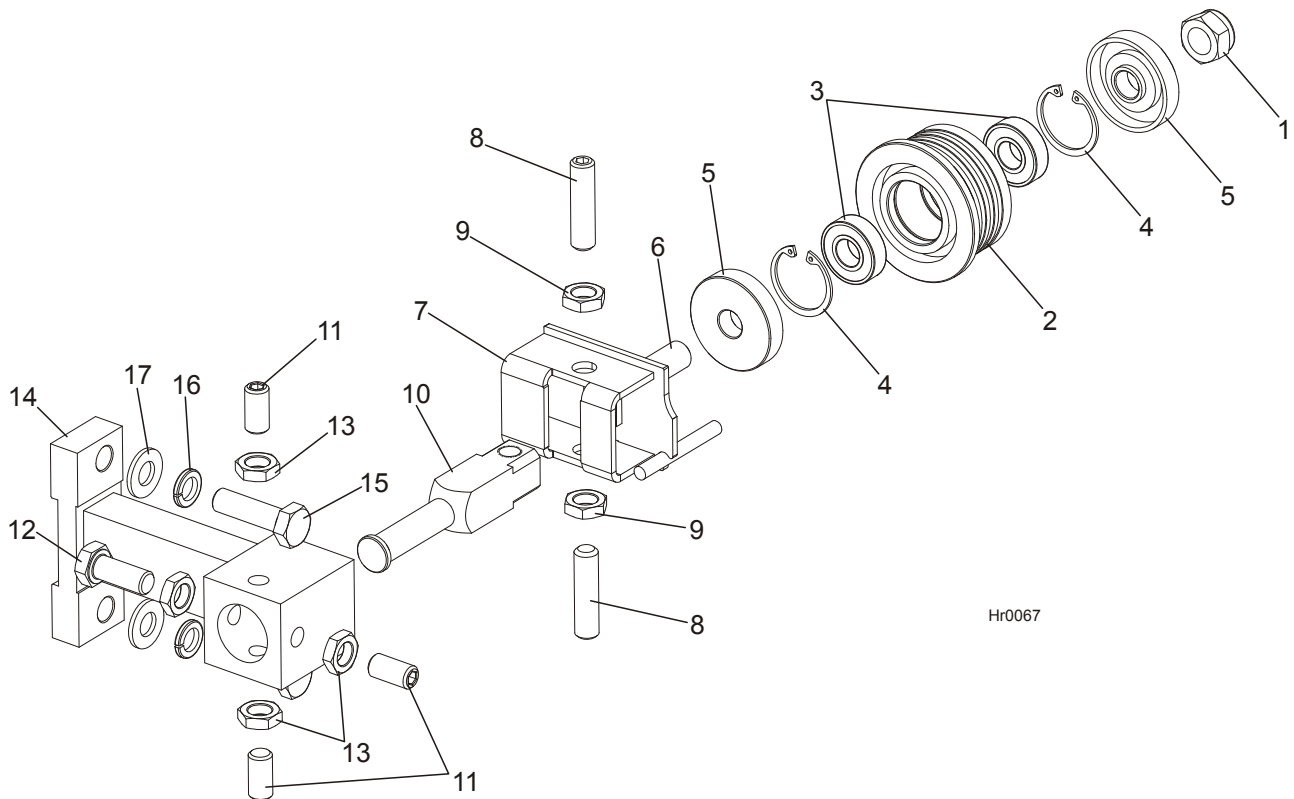

Hr0067

REF	DESCRIPTION (◆ Indicates Parts Available In Assemblies Only)	PART #	QTY.
	<b>BLADE GUIDE ASSEMBLY, DRIVE SIDE</b>	505612	1
	ROLLER, BLADE GUIDE COMPLETE STANDARD	087887	1
1	Nut, M12-8 Hex Nylon Zinc Lock	F81034-2	1
2	Roller, Blade Guide Narrow	087889	1
3	Bearing, 6001 2RSR FAG	087893	2
4	Ring, W28 Inside Retaining	F81090-9	1
5	Washer, Zinc-plated Spacer	087891-1	2
6	Shaft, Blade Guide Roller Zinc-plated	087763-1	1
7	BRACKET WELDMENT, BLADE GUIDE PAINTED	094679-1	1
8	SCREW, M10X1X40 DIN 913 A2-70 SET STAINLESS STEEL	F81015-2	2
9	NUT, M10X1-04-ST-A2 ISO 8675 THIN	F81033-10	2
10	SHAFT, ZINC-PLATED BLADE GUIDE MOUNT	088255-1	1
11	<b>SCREW, M10X1X20 DIN 913 SET STAINLESS STEEL</b>	F81015-1	3
12	<b>BOLT, M10X1X25 DIN 933 STAINLESS STEEL</b>	F81003-28	1
13	<b>NUT, M10x1-04-ST-A2 ISO 8675 THIN</b>	F81033-10	4
14	<b>BRACKET, HR115 BLADE GUIDE DRIVE SIDE</b>	504119-1	1
15	<b>BOLT, M10X35-8.8 HEX HEAD FULL THREAD ZINC</b>	F81003-17	2
16	<b>WASHER, 10.2 SPLIT LOCK ZINC</b>	F81055-2	2
17	<b>WASHER, 10.5 FLAT ZINC</b>	F81055-1	2

### 2.3 Blade Guide Roller Guards

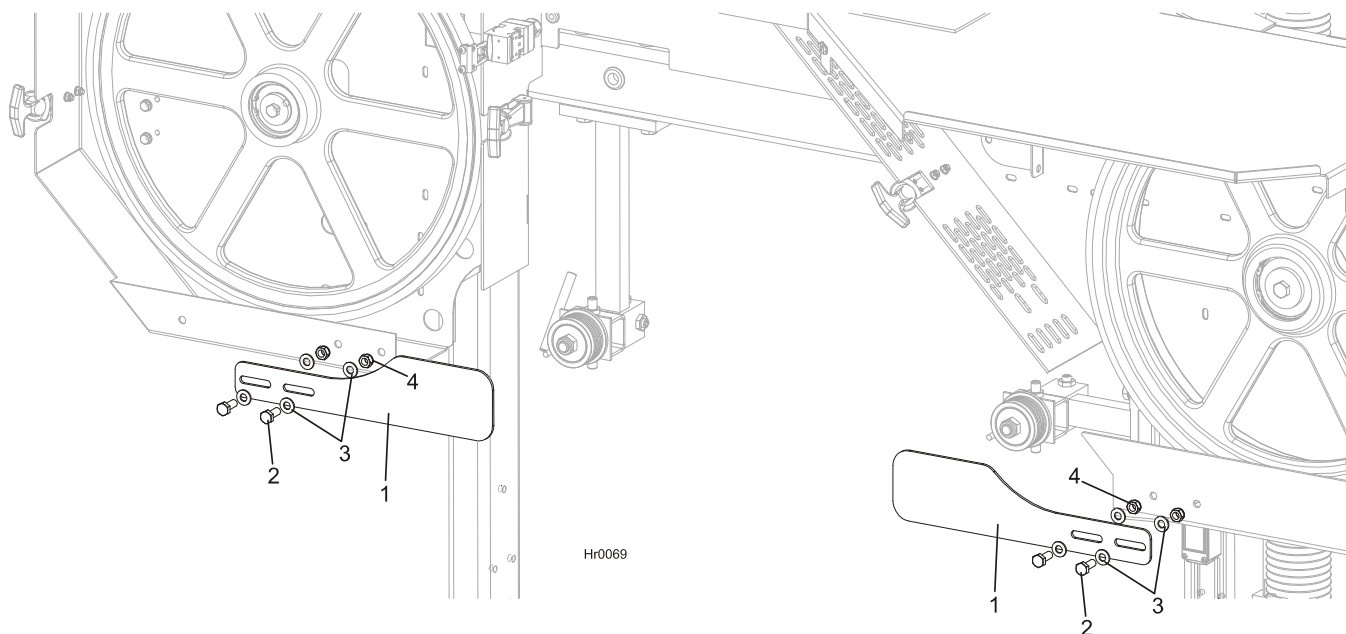

REF	DESCRIPTION (◆ Indicates Parts Available In Assemblies Only)	PART #	QTY.	
1	GUARD, HR110/115 BLADE GUIDE ROLLER	504870-1	2	
2	BOLT, M8X20MM HH GR 8.8 FULL THRD ZINC	F81002-1	4	
3	WASHER, 8.4 FLAT ZINC	F81054-1	8	
4	NUT, M8-8-B HEX NYLON LOCK ZINC	F81032-2	4	

## SECTION 3 BLADE WHEELS & TENSIONER

### 3.1 Blade Wheel Assembly, Drive Side

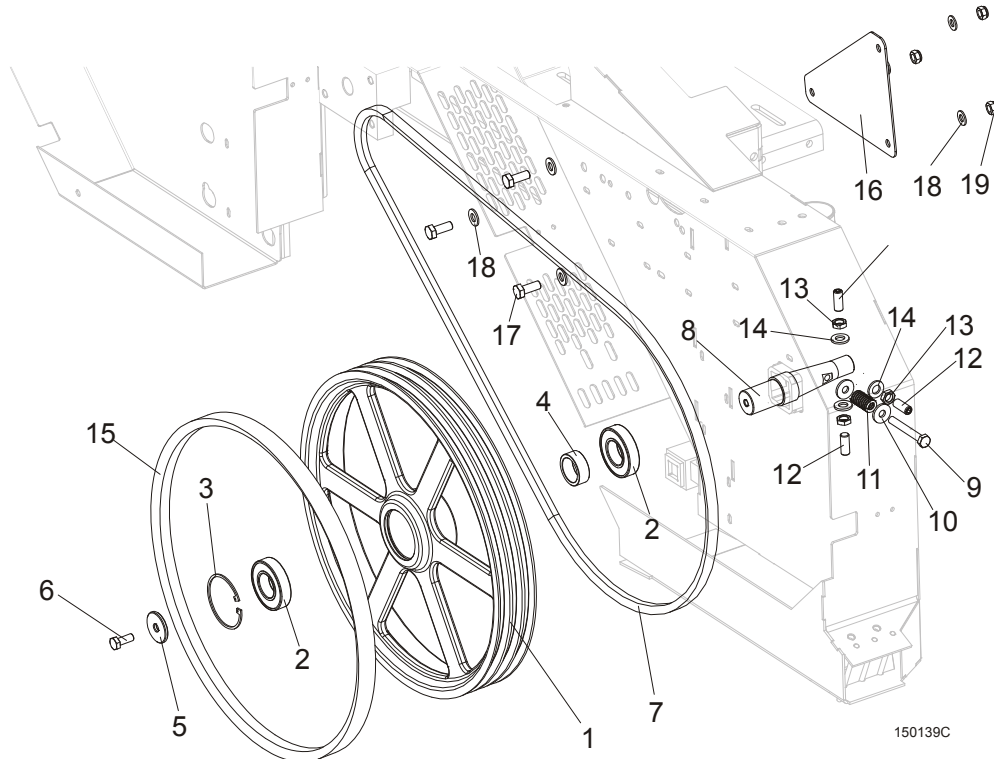

REF	DESCRIPTION (◆ Indicates Parts Available In Assemblies Only)	PART #	QTY.
	<b>BLADE WHEEL ASSEMBLY, LT15 DRIVE SIDE</b>	093849	1
1	WHEEL, LT15 DRIVE SIDE BLADE	014727 <sup>1</sup>	1
2	BEARING, 6207-2RS 35X72X17 FAG	014811 <sup>2</sup>	2
3	RING, 72MM N5002-281 RETAINING	F04254-30	1
4	BUSHING, LT15 BEARING SPACER	093851	1
5	WASHER, LT15 DRIVE SIDE BLADE WHEEL	086286	1
6	BOLT, M10X25-8.8 HEX HEAD FULL THREAD ZINC	F81003-11	1
7	V-BELT, BX81, LT15	014819	1 <sup>3</sup>
8	SHAFT, LT15 DRIVE SIDE BLADE WHEEL	093850	1
9	BOLT, M10X75-8.8 HEX HEAD ZINC	F81003-15	1
10	WASHER, 10.5 SPECIAL FLAT ZINC	F81055-6	2
11	SPRING, 19X38 COMPRESSION	034430	1
12	SCREW, M12X1,25X30 DIN913 SET STAINLESS STEEL	F81016-1	3
13	NUT, M12X1.25 DIN439 THIN STAINLESS STEEL	F81034-9	3
14	WASHER, 13 FLAT ZINC	F81056-1	3
15	V-BELT, B57	P04185-2	1
16	CAP, BOLTED PTD	094247-1	1
17	BOLT, M8X20-5.8 HEX HEAD FULL THREAD ZINC	F81002-1	3
18	WASHER, 8.4 FLAT ZINC	F81054-1	6
19	NUT, M8-8-B HEX NYLON ZINC LOCK	F81032-2	3

<sup>1</sup> LT15 for Russian market is equipped with drive wheel No. 090646-1

<sup>2</sup> LT15 for Russian market is equipped with one bearing 014811 and one 092005 (wide)

<sup>3</sup> LT15 for Russian market is equipped with two belts.

### 3.2 Blade Wheel Assembly, Idle Side

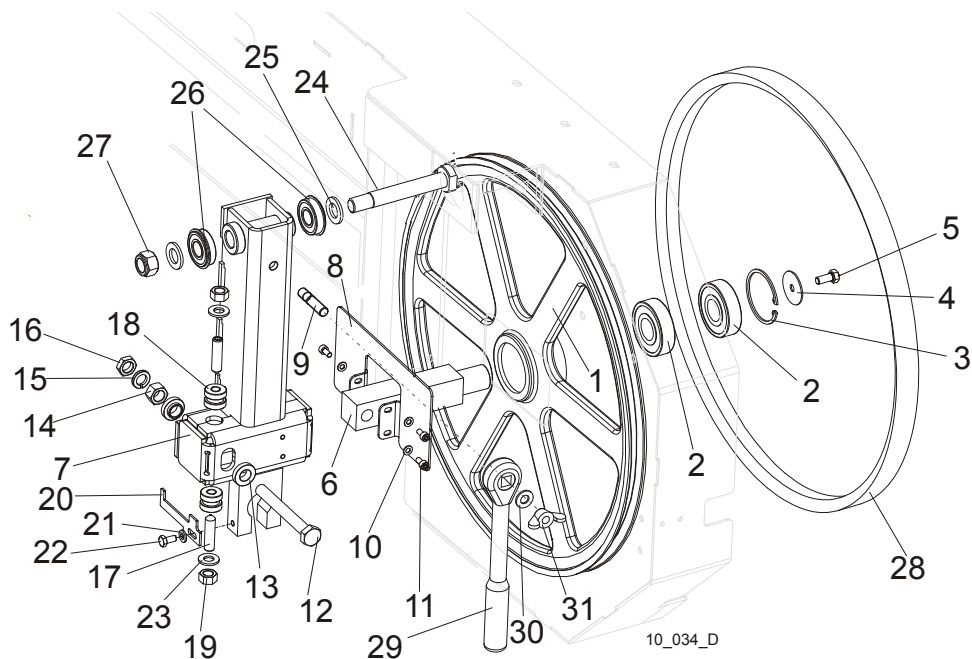

REF	DESCRIPTION (◆ Indicates Parts Available In Assemblies Only)	PART #	QTY.
	<b>WHEEL ASSEMBLY, IDLE SIDE BLADE</b>	<b>A08218</b>	<b>1</b>
1	WHEEL ASSEMBLY, 18.62" BLADE IDLE SIDE	P08125	1
2	BEARING, 6305 2RS NSK IDLE SIDE WHEEL	P08066	2
3	RING, 2 7/16" INSIDE RETAINING	F04254-21	1
	<b>HOUSING, LT10 &amp; LT15 IDLER SHAFT, COMPLETE</b>	<b>100180</b>	<b>1</b>
4	WASHER, IDLE SIDE WHEEL RETAINING	093854-1	1
5	BOLT, M8X25-8.8-B HEX HEAD FULL THREAD ZINC	F81002-5	1
6	SHAFT, IDLE SIDE BLADE WHEEL (METRIC)	096045	1
	<b>HOUSING, IDLER SHAFT COMPLETE</b>	<b>508145</b>	<b>1</b>
7	HOUSING, IDLER SHAFT WELDED/PAINTED	508144-1	1
8	COVER, HOUSING, IDLER SHAFT COMPLETE PAINTED	508128-1	1
9	BOLT M10X35-8.8	F81003-9	1
10	WASHER, 5.3 FLAT ZINC	F81052-1	3
11	SCREW, M5x10 DIN912 A2-70 HEX SOCKET HEAD	F81000-23	3
12	BOLT, M12X1,25X100-8.8 HEX HEAD FULL THREAD ZINC	F81004-41	1
13	WASHER, FLANGED ZINC-PLATED	086769-1	2
14	NUT, M12X1,25 -8 HEX ZINC	F81034-8	1
15	WASHER, 12.2 SPLIT LOCK ZINC	F81056-2	1
16	NUT, M12x1.25 DIN439 THIN STAINLESS STEEL	F81034-5	1
17	SCREW, M10X40-45H CONE POINT HEX SOCKET	F81003-61	2
18	BUSHING, M10 IDLER SHAFT HOUSING	086987	2
19	NUT, M10-8-B HEX HEAD ZINC	F81033-3	2
20	INDICATOR, LT15/LT20 PTD BLADE TENSION	092467-1	1
21	WASHER, 6.4 FLAT ZINC	F81053-1	1
22	BOLT, M6x12-8.8 HEX HEAD FULL THREAD ZIN	F81001-7	1
23	WASHER, 10.5 FLAT ZINC	F81055-1	2
24	<b>PIN, IDLER ARM MOUNT</b>	086404	1

25	WASHER, 17 FLAT ZINC	F81058-1	2	
26	BEARING, 6203-2RS NR NSK W/SNAP RING	086395	2	
27	NUT, M16-8 HEX NYLON ZINC LOCK	F81036-2	1	
28	V-BELT, B57	P04185-2	1	
29	Wrench, LT20 Blade Tension	091620	1	
30	WASHER, 10.5 FLAT ZINC	F81055-1	1	
31	NUT WING M10	F81033-8	1	

### 3.3 Blade Tensioner Assembly

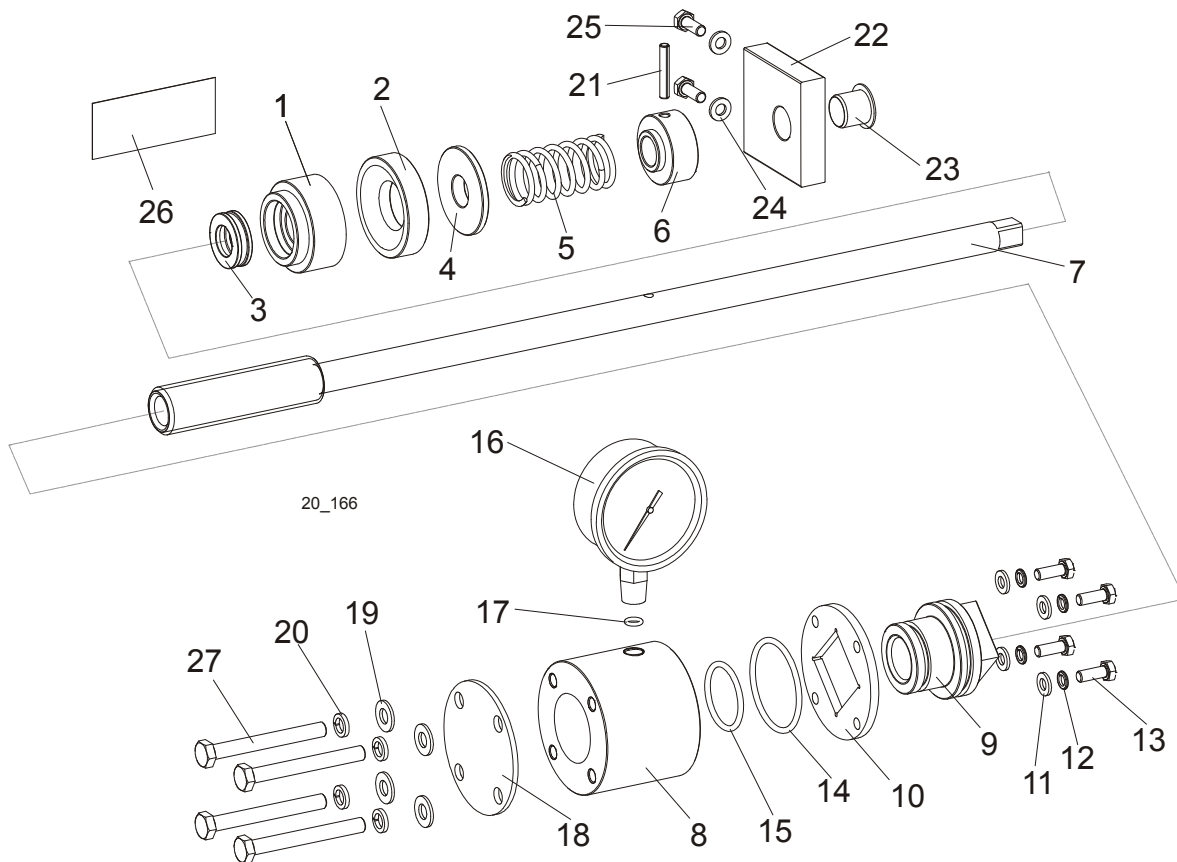

REF.	DESCRIPTION (◆ Indicates Parts Available In Assemblies Only)	PART #	QTY.
	<b>COMPLETE BLADE TENSIONER</b>	<b>510640</b>	<b>1</b>
1	HOUSING, BALL THRUST BEARING	510635	1
2	SOCKET, BEARING HOUSING	510634-1	1
3	BEARING, 51103. BALL THRUST	086675	1
4	WASHER	510633-1	1
5	SPRING, n3mm	088992	1
6	BUSHING, BLADE TENSIONER SCREW	510636-1	1
7	SCREW, BLADE TENSIONER ZINC-PLATED	510650-1	1
	<b>CYLINDER ASSEMBLY</b>	<b>510641</b>	<b>1</b>
8	CYLINDER	510637-1	1
9	PISTON	510638	1
10	PLATE, CYLINDER	510490-1	1
11	WASHER, 6.4 FLAT ZINC	F81053-1	4
12	WASHER, Z 6.1 SPLIT LOCK ZINC	F81053-3	4
13	BOLT, M6x16-8.8 HEX HEAD FULL THREAD ZINC	F81001-15	4
14	O-RING, 46.2x3	510646	1
15	O-RING, 32.2x3	510647	1
16	GAUGE, 3000psi/200 bar OIL PRESSURE	505176	1
17	O-RING, 6.2x2	510648	1
18	PLATE, CYLINDER COVER	510642-1	1
19	WASHER, 8.4 FLAT ZINC	F81054-1	4
20	WASHER, 8.2 SPLIT LOCK ZINC	F81054-4	4

<b>21</b>	PIN, 5x30 ROLL ZINC	F81044-21	1	
<b>22</b>	BLOCK, TENSIONER HANDLE MOUNT	096730	1	
<b>23</b>	BUSHING, GFM-1618-17	089589	1	
<b>24</b>	WASHER, 6.4 FLAT ZINC	F81053-1	2	
<b>25</b>	BOLT, M6x16-8.8 HEX HEAD FULL THREAD ZINC	F81001-15	2	
<b>26</b>	DECAL, PRESSURE VALUES	510643	1	
<b>27</b>	BOLT, M8x70-8.8 HEX HEAD ZINC	F81002-71	4	

### 3.4 Motor Assembly, HR110

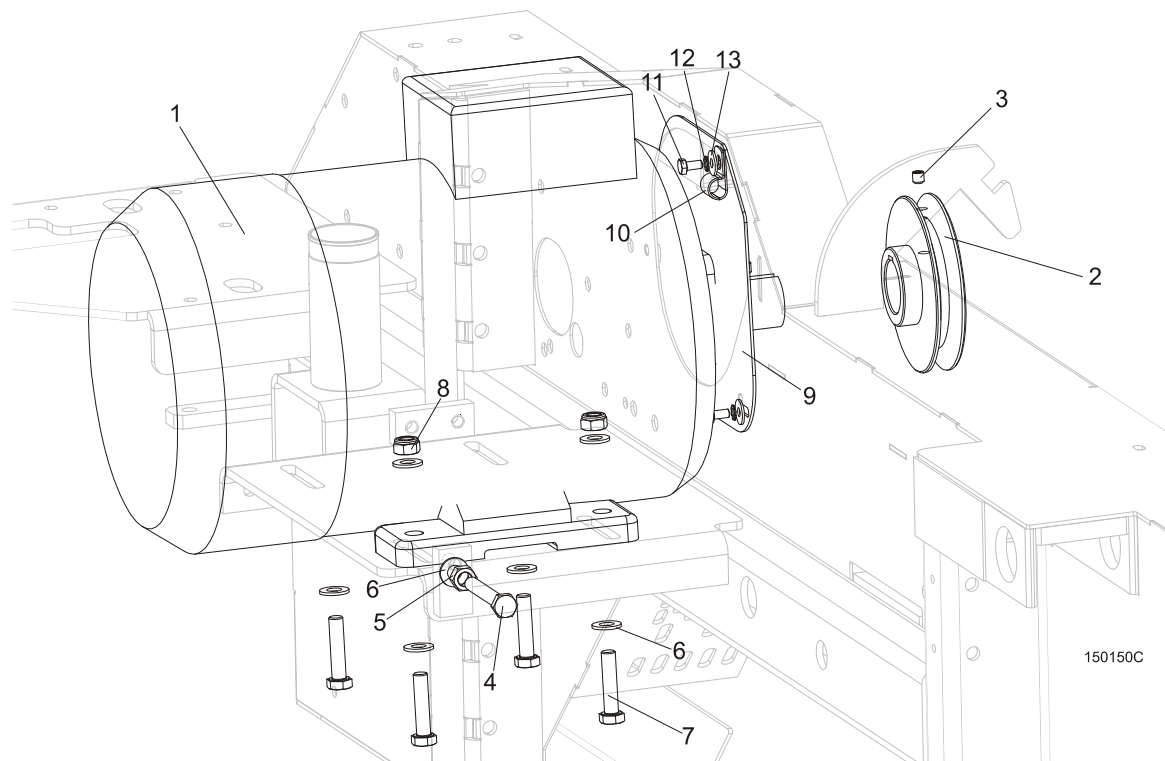

REF	DESCRIPTION (◆ Indicates Parts Available In Assemblies Only)	PART #	QTY.
1	MOTOR, 5.5kW 400V 1LE1002 1CA03-4AA0 ELECTRIC	095785	1
2	PULLEY, LT15 E11 MOTOR ZINC-PLATED	086807-1	1
3	SCREW, M8X8-33H HEX SOCKET SET FLAT POINT ZINC	F81014-1	1
4	BOLT, M10X80-8.8 HEX HEAD FULL THREAD ZINC	F81003-76	2
5	NUT, M10-8-B HEX ZINC	F81033-3	2
6	WASHER, 10.5 FLAT ZINC	F81055-1	10
7	BOLT, M10X45-8.8 HEX HEAD FULL THREAD ZINC	F81003-3	4
8	NUT, M10-8-B HEX NYLON ZINC LOCK	F81033-1	4
9	MOTOR SHAFT COVER, PAINTED, E11/E15	095335-1	1
10	CLAMP, 1/2" EMT COATED	010748	1
11	BOLT M6X12-8.8-FE/ZN5	F81001-7	3
12	WASHER, 6.4 EXTERIOR STAR LOCK ZINC	F81053-2	3
13	WASHER, 6.5 SPECIAL FLAT ZINC	F81053-11	3



### 3.5 Motor Assembly HR115

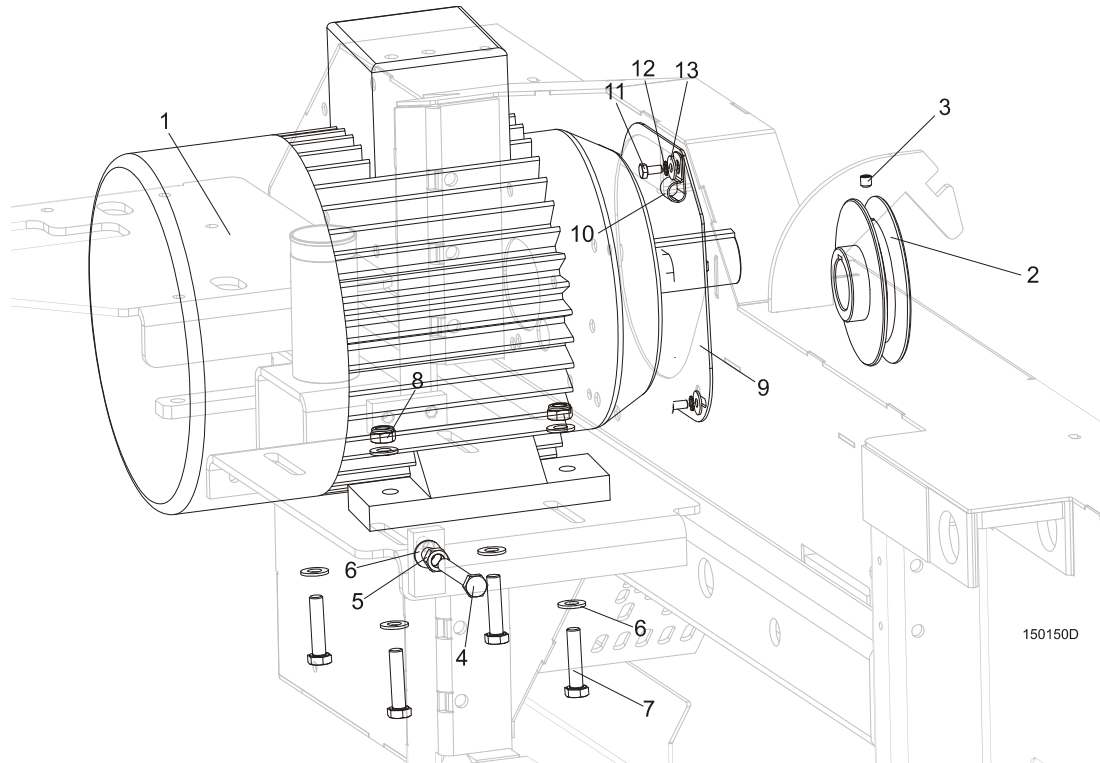

REF	DESCRIPTION (◆ Indicates Parts Available In Assemblies Only)	PART #	QTY.
1	MOTOR, SILNIK Sg132S-2B-HM 400V CE(E11)	090993	1
	MOTOR (7.5KW)11KM 1LA7131-2AA6, 400V (E11)	085482	1
	MOTOR SG132S-2PC, 400 V CE (E15)	089049	1
	MOTOR, ELECTRIC, 11KW,3-PHASE, 400V (PL) (E15)	P85186	1
	MOTOR, ELECTRIC, 11KW,3-PHASE, 400V FOR HR115EH15-1 EC(PL) (E15)	P85186	1
2	PULLEY, LT15 E11 MOTOR ZINC-PLATED (FOR E11 MOTORS)	086807-1	1
	PULLEY, E15 2-GROOVE (FOR E15 MOTORS)	091560	1
3	SCREW, M8X8-33H HEX SOCKET SET FLAT POINT ZINC	F81014-1	1
4	BOLT, M10X80-8.8 HEX HEAD FULL THREAD ZINC	F81003-76	2
5	NUT, M10-8-B HEX ZINC	F81033-3	2
6	WASHER, 10.5 FLAT ZINC	F81055-1	10
7	BOLT, M10X45-8.8 HEX HEAD FULL THREAD ZINC	F81003-3	4
8	NUT, M10-8-B HEX NYLON ZINC LOCK	F81033-1	4
9	MOTOR SHAFT COVER, PAINTED, E11, E15	086787	1
10	CLAMP, 1/2" EMT COATED	P07584	1
11	BOLT M6X12-8.8-FE/ZN5	F81001-7	3
12	WASHER, M6, STAR, LOCK, ZINC	F81053-2	3
13	WASHER, 6,5 POW.FE/ZN5 EXT	F81053-11	3

## SECTION 4 SAW HEAD & FEED TRACK

### 4.1 Blade Housing Cover

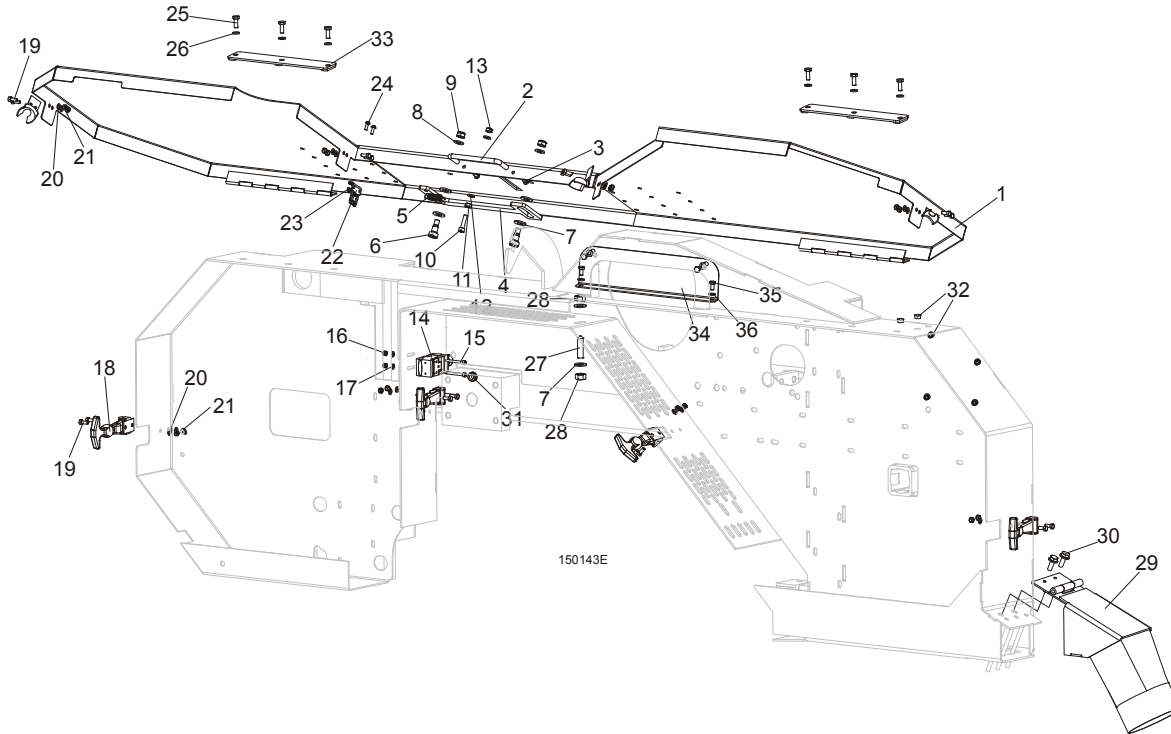

REF	DESCRIPTION (◆ Indicates Parts Available In Assemblies Only)	PART #	QTY.
	<b>COVER, LT15 FRONT COMPLETE</b>	098678	1
1	Cover Weldment, LT10/15/20 Blade Housing Painted	096776-1	1
2	Handle w/Bolt	P08065	1
3	Screw, #8-32x3/8 Self-tapping	F05015-8	2
4	Pawl, Locking Painted	090643-1	1
5	Spring, 1.6x12x38 Extension	092208	1
6	Bolt, 10/M8x12-12.9 ISO-7379 Shoulder	F81003-62	2
7	Washer, 10.5 Flat Zinc	F81055-1	4
8	Washer, 8.4 Flat Zinc	F81054-1	2
9	Nut, M8-8-B Hex Nylon Zinc Lock	F81032-2	2
10	Screw, M6x25-8.8 Hex Socket Head Cap Zinc	F81001-41	1
11	Nut, M6-8 Hex Zinc	F81031-1	1
12	Washer, 6.4 Flat Zinc	F81053-1	2
13	Nut, M6-8-B Hex Nylon Zinc Lock	F81031-2	1
14	<b>SWITCH, AZ17-11ZRK SAFETY</b>	094232	1
15	<b>SCREW, M4X35-8.8 HEX SOCKET HEAD CAP ZINC</b>	F81011-34	2
16	<b>NUT, M4-B HEX NYLON ZINC LOCK</b>	F81029-1	2
17	<b>WASHER, 4.3 FLAT ZINC</b>	F81051-2	2
18	<b>LATCH, FLEXIBLE DRAW</b>	014829	4
19	<b>BOLT, M5X12-5.8 HEX HEAD FULL THREAD ZINC</b>	F81000-5	8
20	<b>WASHER, 5.3 FLAT ZINC</b>	F81052-1	8
21	<b>NUT, M5-8 DIN 985 ZINC-PLATED</b>	F81030-2	8

22	KEY, A217/170-B5 SAFETY SWITCH	094422	1	
23	NUT, M4-B HEX NYLON ZINC LOCK	F81029-1	2	
24	SCREW, M4X12-5.8-B CROSS RECESSED PAN HEAD ZINC	F81011-43	2	
25	BOLT, M6X16 8.8 HEX HEAD FULL THREAD ZINC	F81001-15	6	
26	WASHER, 6.4 FLAT ZINC	F81053-1	6	
27	SCREW, M10X40-45H HEX SOCKET SET CONE POINT ZINC	F81003-61	1	
28	NUT, M10-8-B HEX ZINC	F81033-3	2	
29	CHUTE, LT10/15/20 SAWDUST	100903-1	1	
30	BOLT, M8X16-8.8-B HEX HEAD FULL THREAD ZINC	F81002-20	2	
31	GROMMET, 22mm DIA. RUBBER	087400	1	
32	PLUG, SR1086-9,5	096846	6	
33	PLATE, COVER MOUNT	086701-1	2	
34	COVER, SAW HEAD MOUNT	096788-1	1	
35	BOLT, M6X12MM HEX HEAD ZINC	F81001-7	4	
36	WASHER, M6 FLAT ZINC	F81053-1	4	

**4.2 Water Lube Assembly**

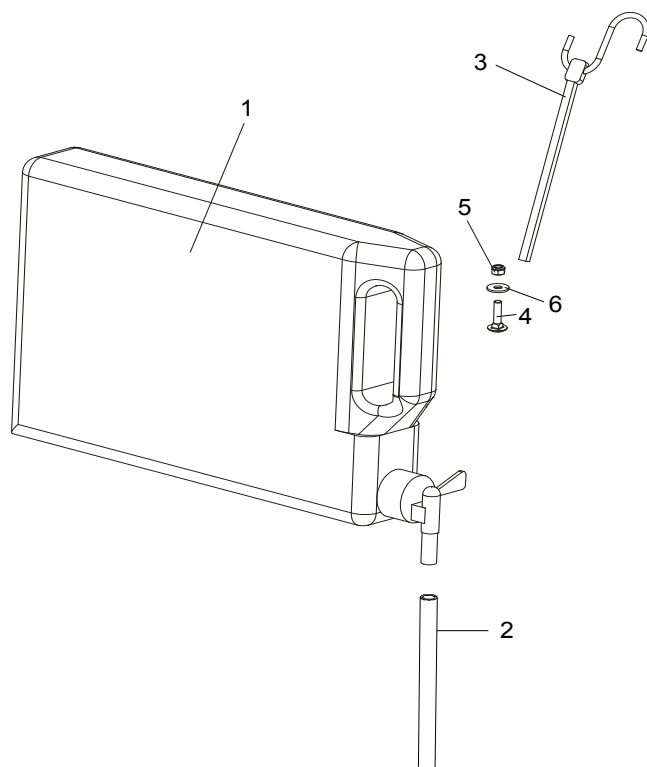

REF	DESCRIPTION (◆ Indicates Parts Available In Assemblies Only)	Part #	Qty.
1	Bottle, 5-liter Water	049119	1
2	Tube, 3/8" I.D. Water Lube	R01885	1,7 m
3	Strap, 24" Rubber w/Hook	P11258	2
4	Bolt, M6x25-8.8 Mushroom Head Square Neck Zinc	F81001-20	1
5	Nut, M6-8-B Hex Nylon Zinc Lock	F81031-2	1
6	Washer, 6.5 Special Flat Zinc	F81053-11	1

## 4.3 Decals, HR110

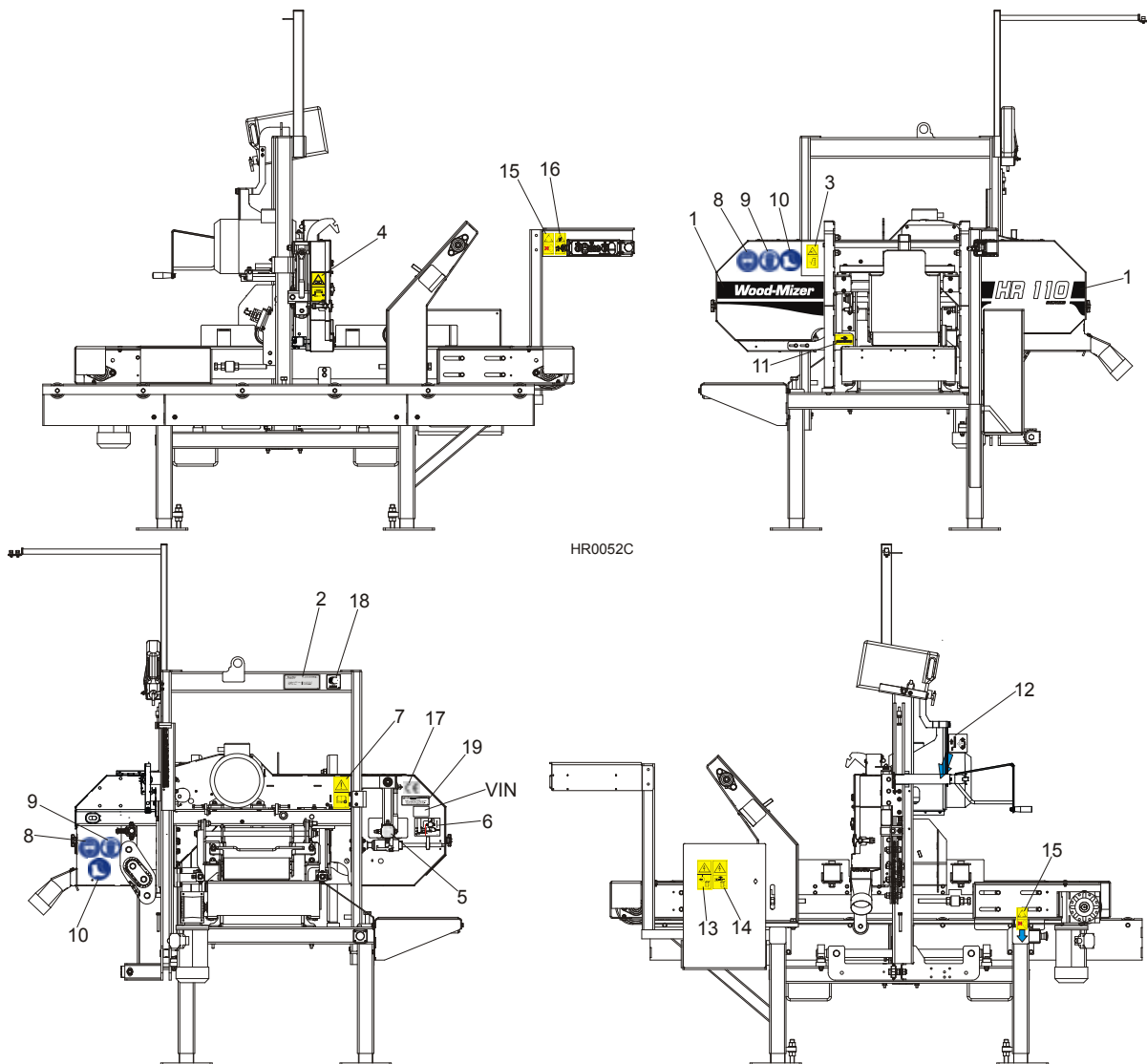

REF	DESCRIPTION (◆ Indicates Parts Available In Assemblies Only)	Part #	Qty.
	<b>PICTOGRAPHIC DECAL KIT, HR110</b>	504240	1
1	DECAL, HR110 SAWMILL NAME	504239	1
2	DECAL, EUROPEAN HEADQUARTERS ADDRESS	015841	1
3	DECAL, SAWMILL COVERS CAUTION	099220	1
4	DECAL, BLADE TENSION (PICTOGRAM)	099219	1
5	DECAL, BLADE ALIGNMENT	P11789	1
6	DECAL, BLADE TENSION INDICATOR ADJUSTMENT	092597	1
7	DECAL, READ OPERATOR'S MANUAL (PICTOGRAM)	096317	1
8	DECAL, EYE PROTECTION WARNING (PICTOGRAM)	S12004G	2
9	DECAL, EAR PROTECTION WARNING (PICTOGRAM)	S12005G	2
10	DECAL, USE SAFETY BOOTS (PICTOGRAM)	501465	2
11	DECAL, BLADE MOVEMENT DIRECTION (PICTOGRAM)	096321	1
12	DECAL, POWER FEED SYSTEM ENGAGEMENT (PICTOGRAM)	099226	1
13	DECAL, HIGH VOLTAGE INSIDE THE ELECTRIC BOX (PICTOGRAM)	096316	1
14	DECAL, REMOVE THE PLUG BEFORE OPENING THE BOX (PICTOGRAM)	096319	1

**4****SAW HEAD & FEED TRACK***Decals, HR110*

---

<b>15</b>	DECAL, GEAR CAUTION	099540	2	
<b>16</b>	DECAL, KEEP A SAFE DISTANCE AWAY	099221	1	
<b>17</b>	DECAL, CE CERTIFIED SAWMILL (SMALL)	P85070	1	
<b>18</b>	DECAL, RUSSIAN SAFETY CERTIFICATION	099401	1	
<b>19</b>	DECAL, INTERNATIONAL SAWMILL NAME	501466	1	
<b>20</b>	DECAL, MOTOR DIRECTION	S20097	1	
<b>21</b>	DECAL, BLADE SETTING	P85066	1	

## 4.4 Control Panel, HR110

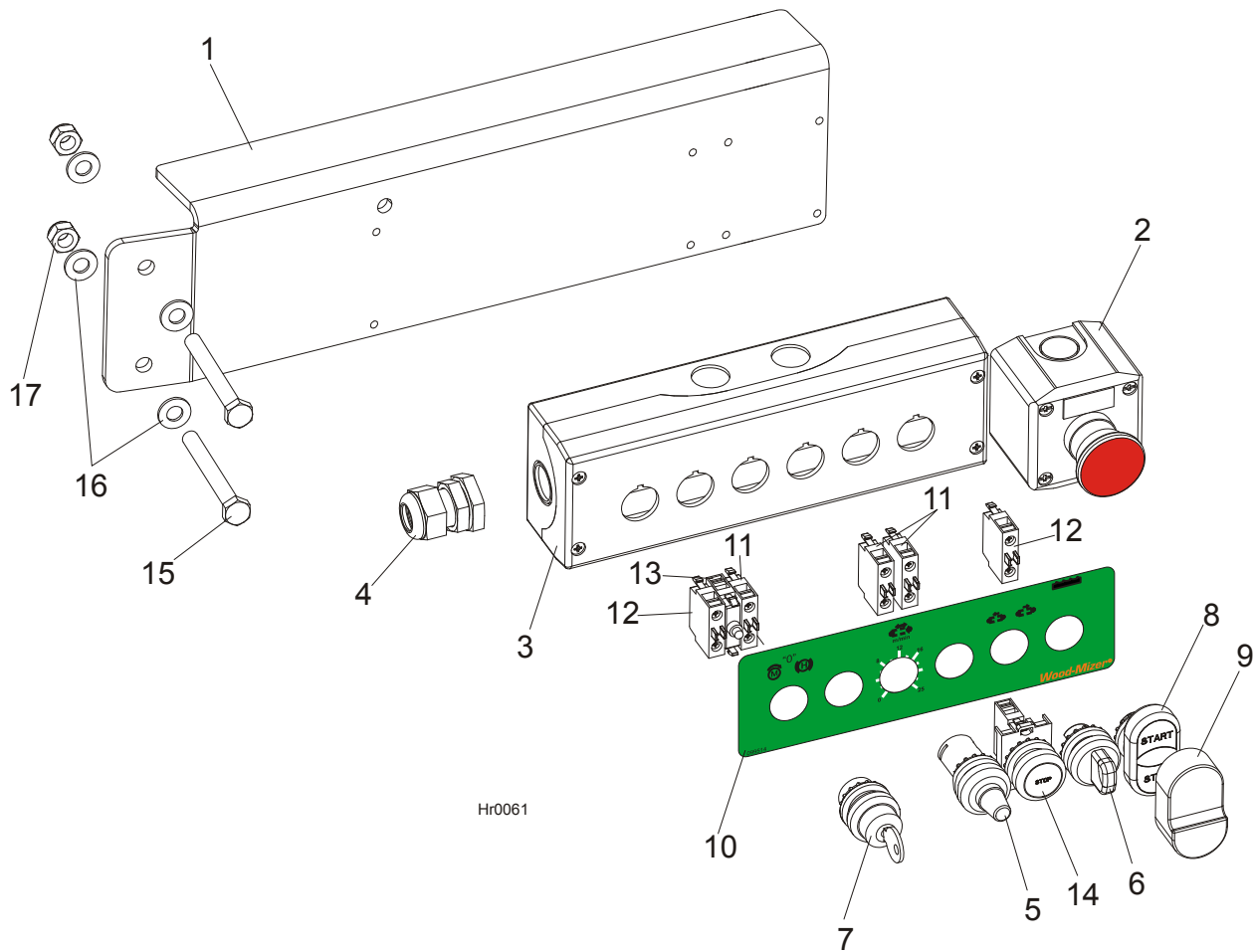

REF	DESCRIPTION (◆ Indicates Parts Available In Assemblies Only)	PART #	QTY.
1	BRACKET, HR115 CONTROL PANEL	505062-1	1
2	SWITCH, XALJ174F EMERGENCY	E22703-P	1
	<b>CONTROL BOX, HR110</b>	503970	1
3	Box, M22-I6 (216540) Control	093750	1
4	Connector, DP 16/H	F81096-7	1
5	Potentiometer, M22-R1K (229489)	093749	1
6	Switch, M22 - 3 Position	091360	1
7	Operator, M22-WRS3 Key Switch	095001	1
8	Operator, M22-DDI-GR-GB1/GB0 Switch	094997	1
9	Membrane M22-T-DD	090462	1
10	Decal, HR130 Control Panel	503969	1
11	Contact Element, M22-KC10	094314	4
12	Contact Element, M22-KC01	094998	2
13	LED Element, M22-LEDC-W	094999	1
14	Button, M22 STOP	090926	1
15	<b>BOLT, M10X90-8.8-B HEX HEAD ZINC</b>	F81003-66	2
16	<b>WASHER, 10.5 FLAT ZINC</b>	F81055-1	4
17	<b>NUT, M10-8-B HEX NYLON ZINC LOCK</b>	F81033-1	2

**4.5 Control Box**

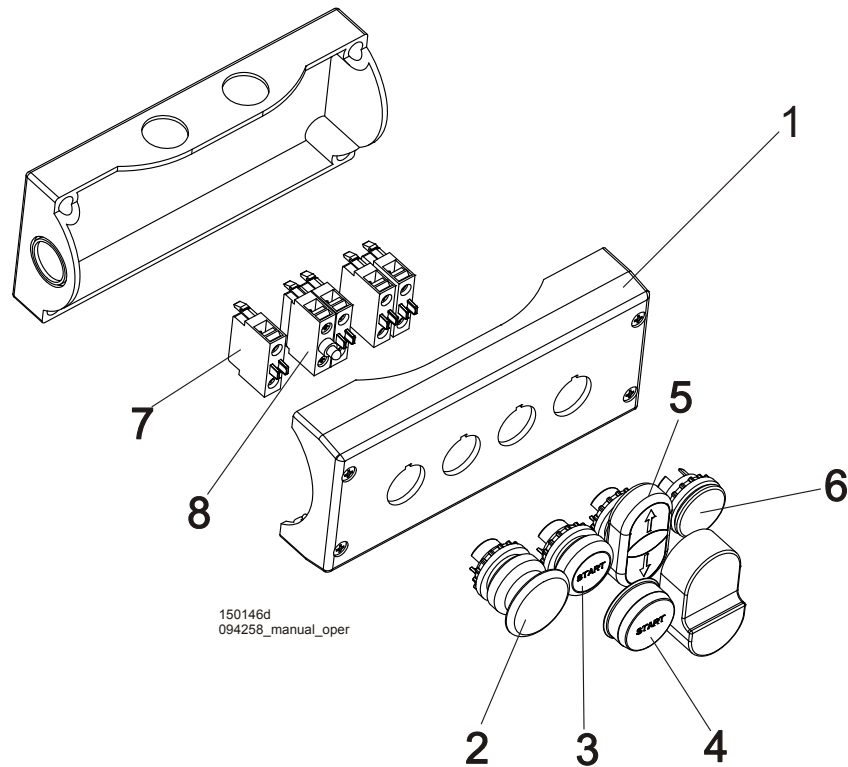

REF	DESCRIPTION (◆ Indicates Parts Available In Assemblies Only)	PART #	QTY.
	<b>BOX, COMPLETE UP/DOWN CONTROL</b>	094258	1
1	HOUSING, CONTROL PANEL	094259	1
2	BUTTON, M22 MOMENTARY MUSHROOM GREEN	094328	1
3	BUTTON, GREEN ILLUMINATED START	094315	1
4	MEMBRANE M22-T-D	094316	1
5	BUTTON, M22-DD-S-X7/X7	090917	1
6	CAP, M22 - B (216388)	093748	1
7	ELEMENT, M22-KC10 CONTACT	094314	4
8	ELEMENT, LED M22-LEDC-G(AC)	099921	1



4.6 Electric Box Decals

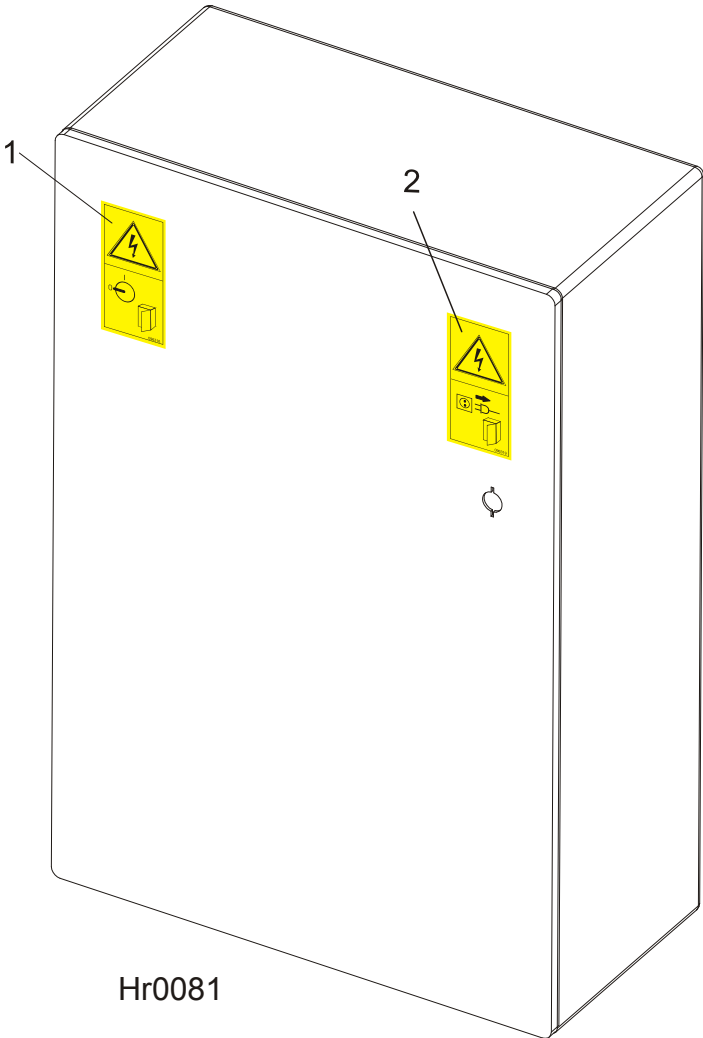

REF	DESCRIPTION (◆ Indicates Parts Available In Assemblies Only)	PART #	QTY.	
	<b>ELECTRIC BOX</b>	503787	1	
1	<b>DECAL, HIGH VOLTAGE INSIDE THE ELECTRIC BOX (PICTOGRAM)</b>	096316	1	
2	<b>DECAL, REMOVE THE PLUG BEFORE OPENING THE BOX (PICTOGRAM)</b>	096319	1	

**4.7 Hold-Down Roller Front**

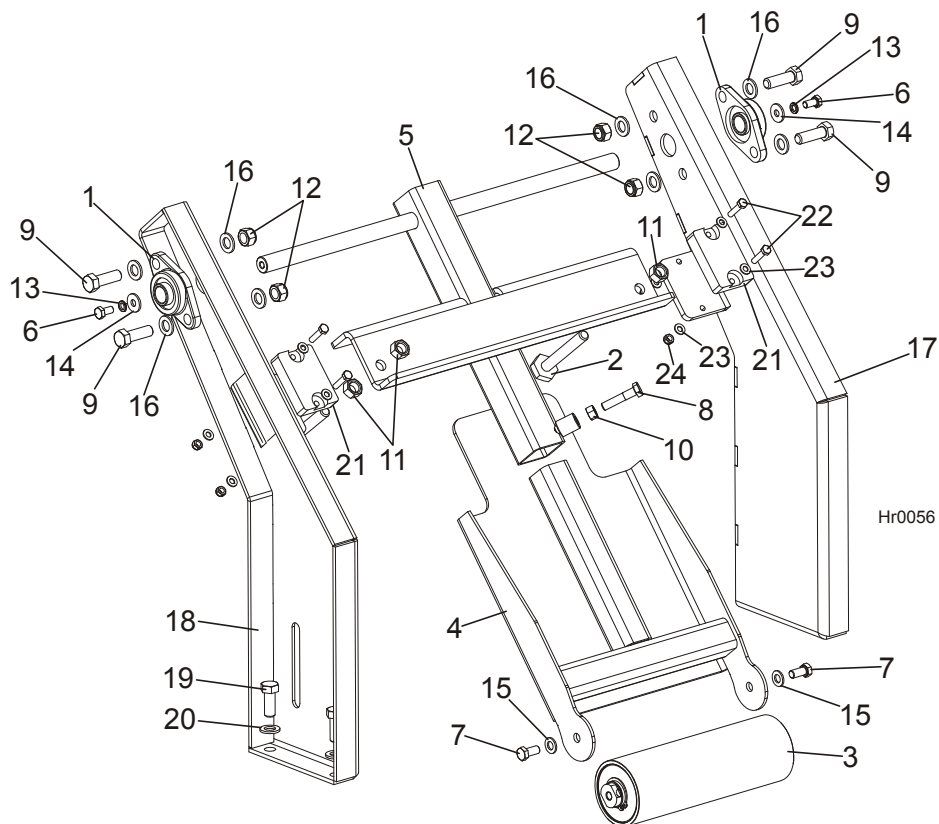

REF	DESCRIPTION (◆ Indicates Parts Available In Assemblies Only)	PART #	QTY.
	<b>ROLLER, HR110/115 HOLD-DOWN FRONT</b>	504526	1
1	BEARING, UCFL 205	089124	2
2	BOLT, M16 ROLLER SUPPORT ZINC	100426-1	2
3	ROLLER, HR110/115 HOLD-DOWN	504130	1
4	BRACKET, HOLD-DOWN ROLLER LOWER	504481-1	1
5	BRACKET, HOLD-DOWN ROLLER UPPER	504483-1	1
6	BOLT, M10X20MM, HEX HEAD, GR 5.8 ZINC	F81003-1	2
7	SCREW, M12X25-8.8-FE/ZN5 PN-M/82105	F81004-31	2
8	BOLT, M12x55 HEX HEAD, GR 5.8 ZINC	F81004-43	1
9	BOLT, M16 X 50-8.8 HEX HEAD	F81006-7	4
10	NUT, M12-8-B ZINC HEX	F81034-1	1
11	NUT, M16-5.8 HEX ZINC	F81036-1	4
12	NUT, M16 HEX NYLON ZINC LOCK	F81036-2	4
13	WASHER, 10.2 SPLIT LOCK ZINC	F81055-2	2
14	WASHER, 10.5 ZINC FLAT SPECIAL	F81055-6	2
15	WASHER, 13 FLAT ZINC	F81056-1	2
16	WASHER, 17 FLAT ZINC	F81058-1	8
17	<b>BRACKET, HOLD-DOWN ROLLER RIGHT</b>	504492-1	1
18	<b>BRACKET, HOLD-DOWN ROLLER LEFT</b>	504493-1	1
19	<b>BOLT, M16X40-8.8 HEX HEAD FULL THREAD ZINC</b>	F81006-13	4
20	<b>WASHER, 17 FLAT ZINC</b>	F81058-1	4

21	BUMPER, GRENE 70 3201 0010. SHR RUBBER	094969	2	
22	BOLT, M8X35-8.8 HEX HEAD FULL THREAD ZINC	F81002-13	4	
23	WASHER, 8.4 FLAT ZINC	F81054-1	8	
24	NUT, M8-8-B HEX NYLON ZINC LOCK	F81032-2	4	

### 4.8 Hold-Down Roller Rear

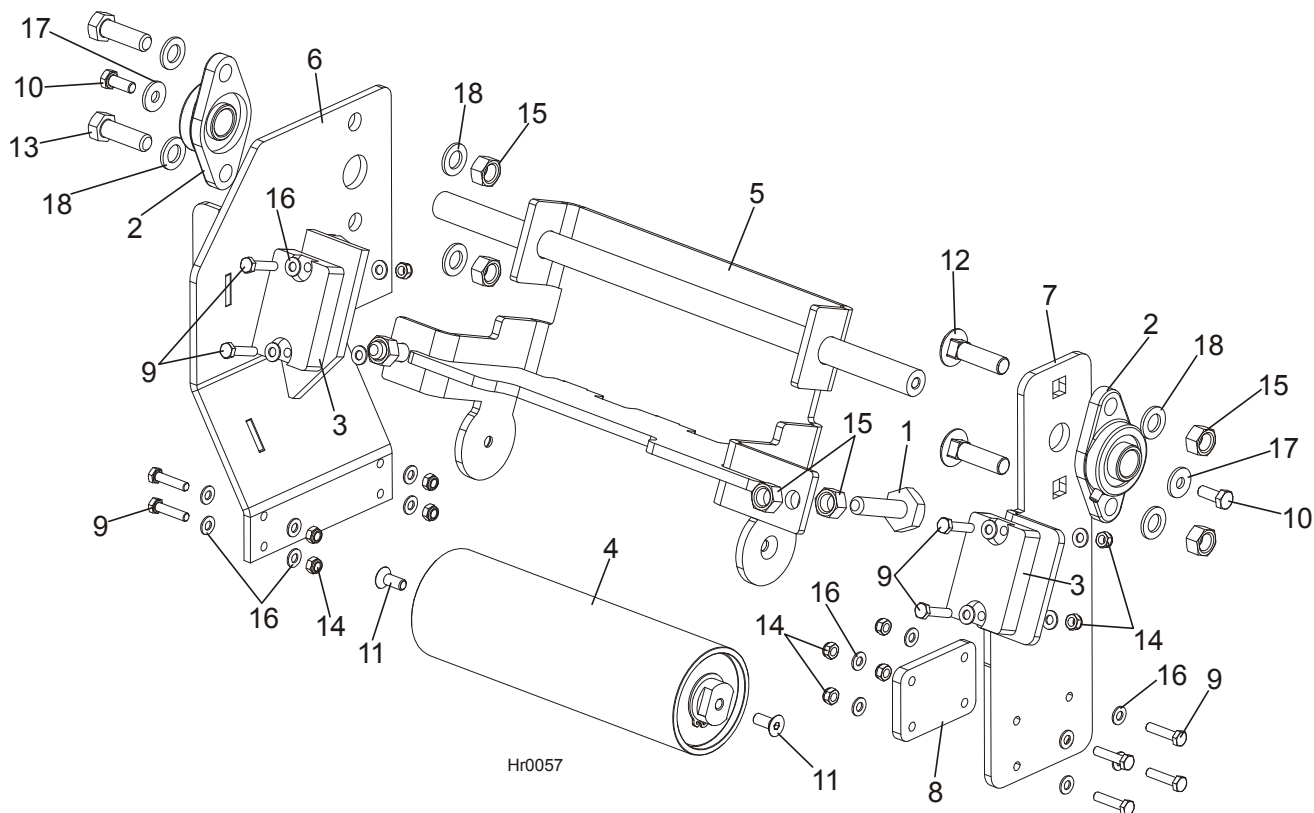

REF	DESCRIPTION (◆ Indicates Parts Available In Assemblies Only)	PART #	QTY.
	<b>ROLLER, HR110/115 HOLD-DOWN REAR</b>	504855	1
1	BOLT, BAD RAIL ADJUSTMENT	505006	2
2	BEARING, UCFL 205	089124	2
3	BUMPER, GRENE 70 3201 0010. SHR RUBBER	094969	2
4	ROLLER, HR110/115 HOLD-DOWN	504130	1
5	BRACKET, HR110/115 ROLLER REAR	504132-1	1
6	BRACKET, HOLD-DOWN ROLLER RIGHT	504521-1	1
7	BRACKET, HOLD-DOWN ROLLER LEFT	504548	1
8	PLATE, HR ROLLER REAR RETAINING	504864-1	1
9	BOLT, M8x35-8.8 HEX HEAD FULL THREAD ZINC	F81002-13	12
10	BOLT, M10X25-8.8-FE/ZN5	F81003-11	2
11	BOLT, M10x25 -10.9- Fe/Zn5 DIN 7991	F81003-82	2
12	BOLT, M16x60-8.8 TRUSS HEAD ZINC	F81006-32	2
13	BOLT, M16 X 50-8.8 HEX HEAD	F81006-7	2
14	NUT, M8-8-B HEX NYLON ZINC LOCK	F81032-2	12
15	NUT, M16-5.8 HEX ZINC	F81036-1	8
16	WASHER, 8.4 FLAT ZINC	F81054-1	24
17	WASHER, 10.5 ZINC FLAT SPECIAL	F81055-6	2
18	WASHER, 17 FLAT ZINC	F81058-1	6

4.9 Infeed, Outfeed & Return Tables

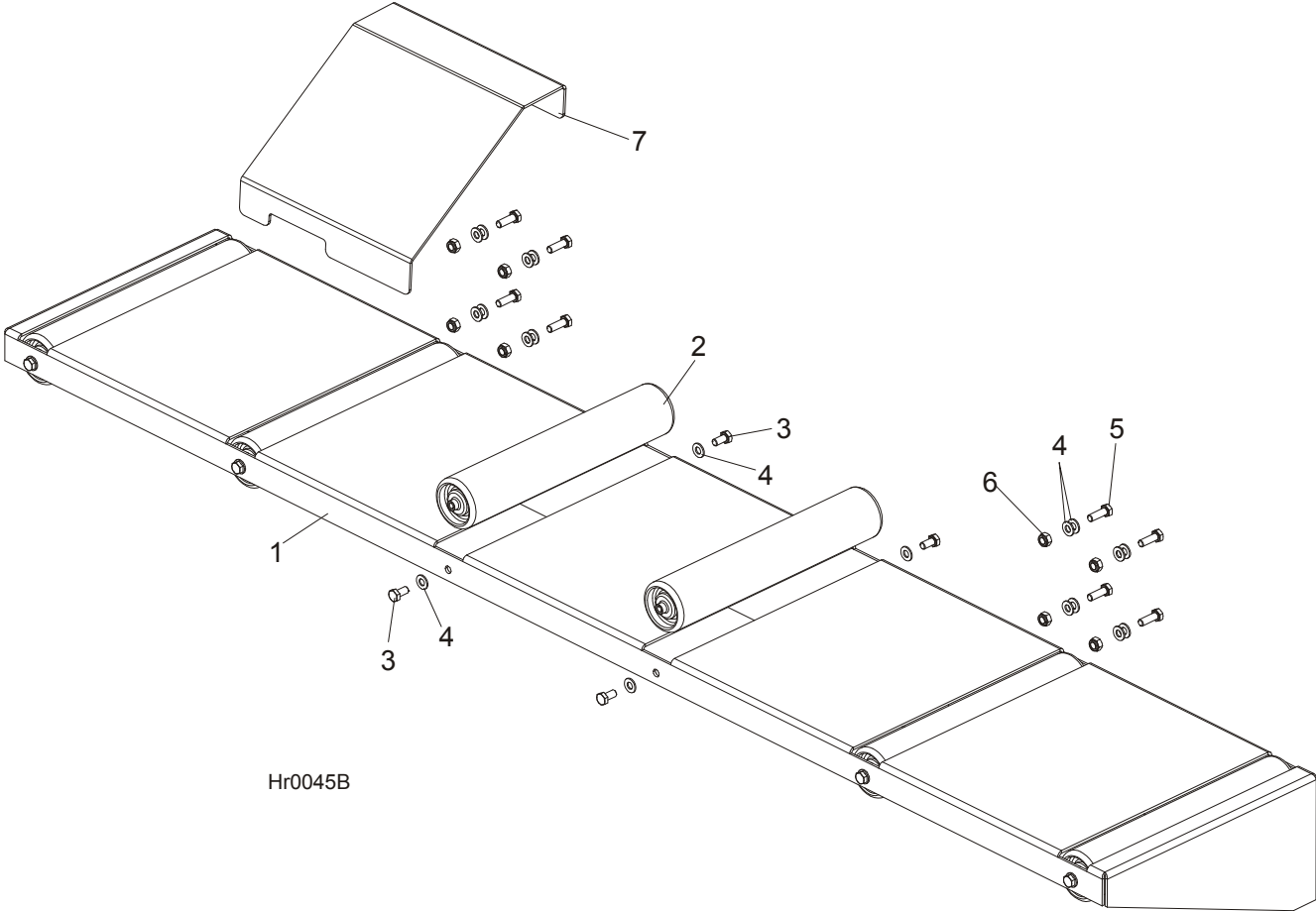

Hr0045B

REF	DESCRIPTION (◆ Indicates Parts Available In Assemblies Only)	PART #	QTY.
	<b>TABLE, HR130 LONG COMPLETE</b>	503966	1
1	TABLE, HR130 LONG	503991-1	1
2	ROLLER, 76x400 W/M10 INTERNAL THREAD	093787	6
3	BOLT, M10x20MM,HEX HEAD,GR 5.8 ZINC	F81003-1	12
4	WASHER, 10.5 FLAT ZINC	F81055-1	28
5	BOLT, M10x30-5.8 HEX HEAD FULL THREAD ZINC	F81003-2	8
6	NUT, M10-8-B HEX NYLON ZINC LOCK	F81033-1	8
7	<b>PLATE, BOARD RETURN</b>	504124-1	1

## 4.10 Feed Track Assembly

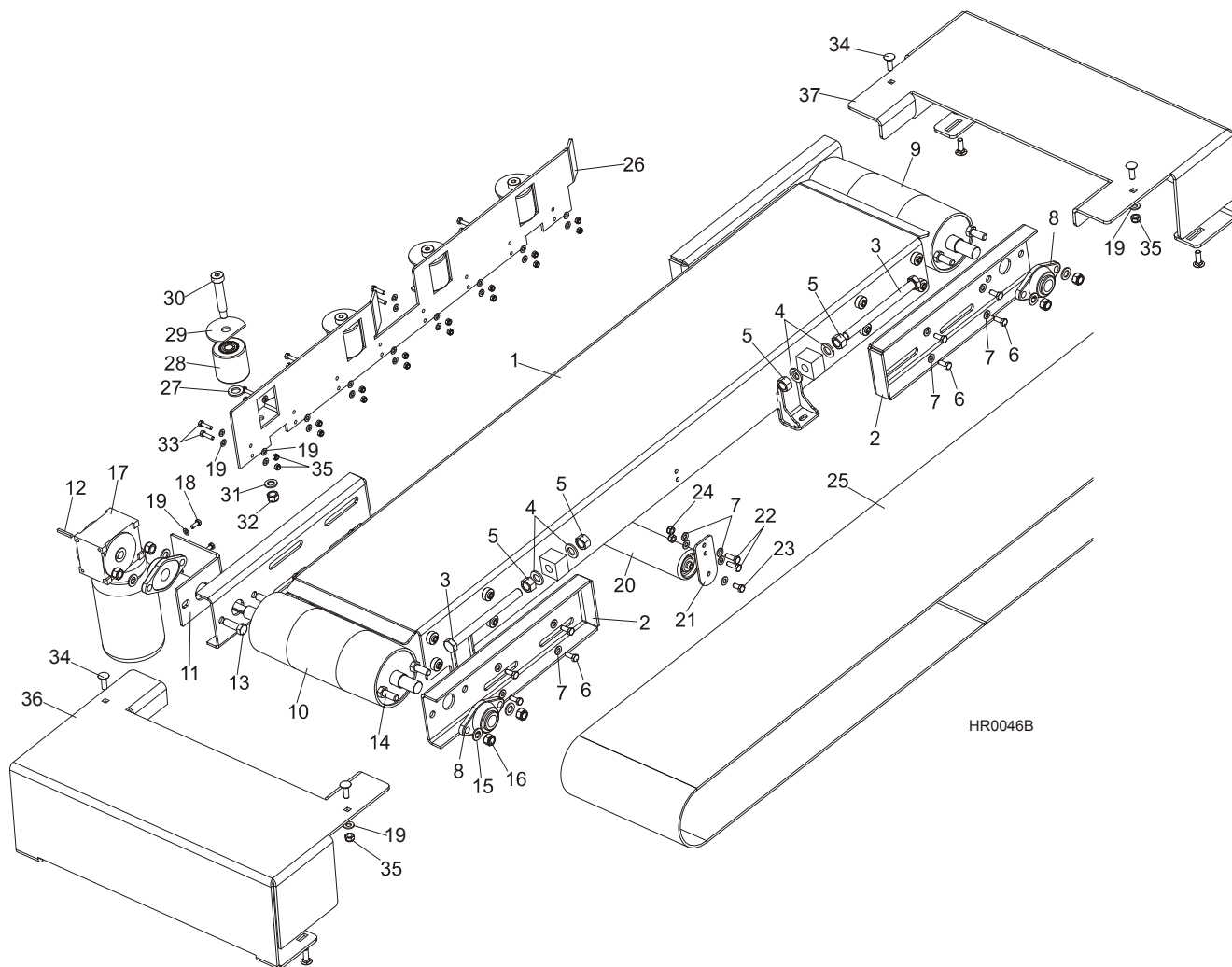

REF	DESCRIPTION (◆ Indicates Parts Available In Assemblies Only)	PART #	QTY.
	<b>TABLE, HR115 COMPLETE</b>	503780	1
1	TABLE, HR10/115	503775-1	1
2	BRACKET, HR300 PULLEY MOUNT PAINTED	504133-1	4
3	BOLT, M20X240-8.8 FE/ZN5 PN-85/M 82105	F81007-1	4
4	WASHER, 21 FLAT ZINC	F81059-2	8
5	NUT, M20-8 HEX ZINC	F81037-1	8
6	BOLT, M10X25-8.8-FE/ZN5	F81003-11	16
7	WASHER, 10.5 FLAT ZINC	F81055-1	26
8	BEARING, UCFL 206 CX BALL	090851	4
9	PULLEY, HR115 IDLE SIDE PAINTED	503776-1	1
10	PULLEY, HR115 DRIVE SIDE WITH VENEER	506519	1
11	BRACKET, GEAR BOX MOUNT PAINTED	504856-1	1
12	KEY, AB 6X6X45 PARALLEL	089229	1
13	BOLT, M16X50-8.8 HEX HEAD FULL THREAD ZINC	F81006-7	2
14	BOLT, M16X40-8.8 HEX HEAD FULL THREAD ZINC	F81006-13	6
15	WASHER, 17 FLAT ZINC	F81058-1	8
16	NUT, M16-8 HEX NYLON ZINC LOCK	F81036-2	8

17	MOTOREDUCER, RA-06/49/F3/N+S/V6	505080	1	
	Motor, Skh 80-4A/3045 0,55kW 1400RPM	083794	1	
18	BOLT, M8X20-5.8 HEX HEAD FULL THREAD ZINC	F81002-1	2	
19	WASHER, 8.4 FLAT ZINC	F81054-1	4	
20	ROLLER, 76x400 W/M10 INTERNAL THREAD	093787	1	
21	SUPPORT, HR115 ROLLER	503782-1	2	
22	BOLT, M10x30-5.8 HEX HEAD FULL THREAD ZINC	F81003-2	4	
23	BOLT, M10X20MM, HEX HEAD, GR 5.8 ZINC	F81003-1	2	
24	NUT, M10-8-B HEX NYLON ZINC LOCK	F81033-1	4	
25	TYPE, EP 250/2 3+0 GRIP B=380 L=4900	503956	1	
	COVERING FOR PULLEYS	R00100	5 m	
	RIVET, P AL/FE 4X10 TUBULAR W/CORE	F81021-11	2	
	RUNNER, SIDE COMPLETE	503985	1	
26	RUNNER, HR130 SIDE	503984-1	1	
27	WASHER, 21 FLAT ZINC	F81059-2	4	
28	ROLLER, R-80-80 SIDE	099429	4	
29	COVER, SIDE ROLLER	503969-1	4	
30	BOLT, 20/M16X90 12.9 ISO7379 FITTED	F81006-30	4	
31	WASHER, 17 FLAT ZINC	F81058-1	4	
32	NUT, M16, HEX, NYLON ZINC LOCK	F81036-2	4	
33	BOLT, M8X30MM, HH, GR 5.8, FULL THRD, ZINC	F81002-2	16	
34	BOLT, M8 X 20 Fe/Zn5, PN-M/82406	F81002-11	8	
35	NUT, M8-8-B HEX NYLON ZINC LOCK	F81032-2	16	
36	COVER, HR110/115 TYPE LEFT	504122-1	1	
37	COVER, HR110/115 TYPE RIGHT	504134-1	1	

**4.11 Table, Idle Roller**

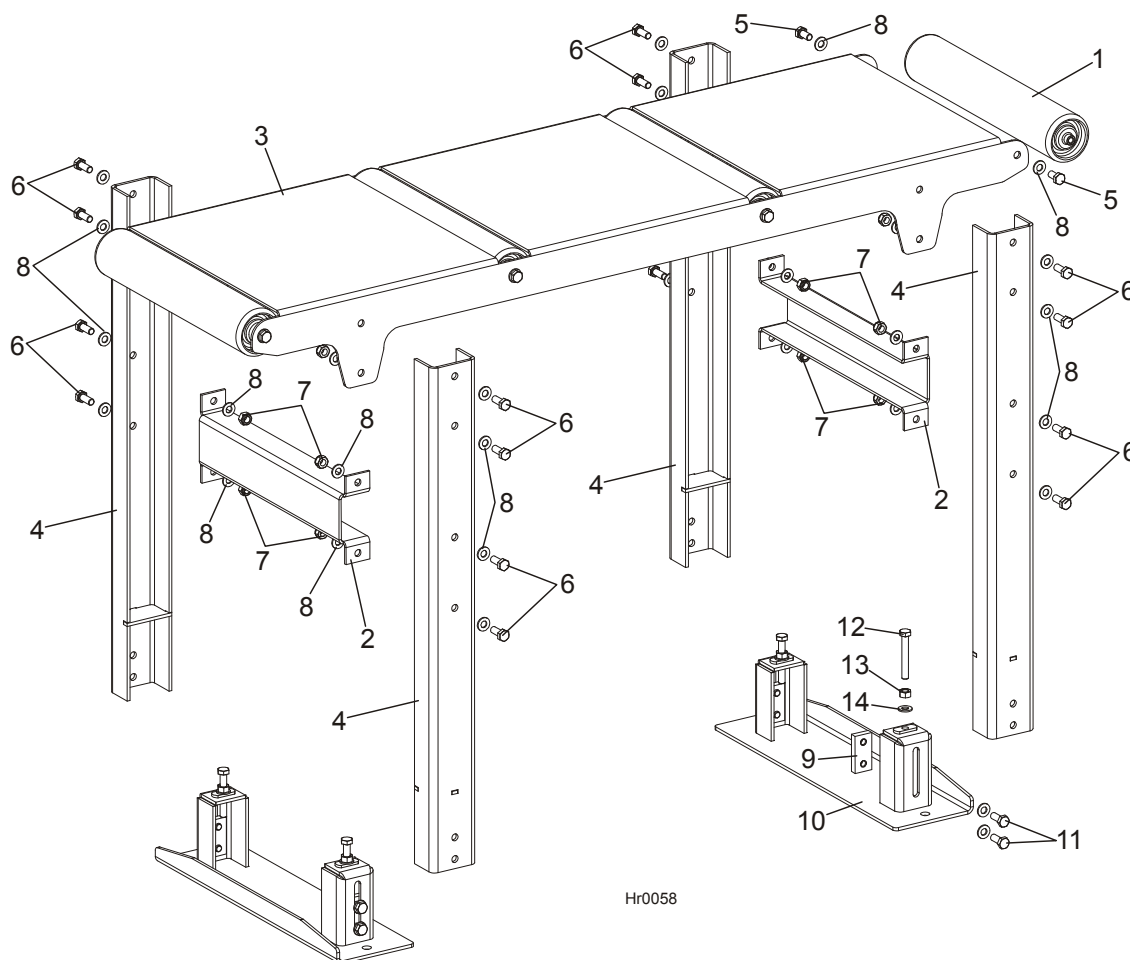

REF	DESCRIPTION (◆ Indicates Parts Available In Assemblies Only)	PART #	QTY.
	<b>TABLE, HR110/115 IDLE ROLLER COMPLETE</b>	504100	1
1	ROLLER, 76x400 W/M10 INTERNAL THREAD	093787	4
2	LINK, TABLE MIDDLE	504096-1	2
3	PLATE, TABLE MOUNTING	504101-1	1
4	SUPPORT, TABLE	504102-1	4
5	BOLT, M10X20MM HEX HEAD GR 5.8 ZINC	F81003-1	8
6	BOLT, M10 X 25 8.8 Fe/Zn5, PN-M/82105	F81003-31	16
7	NUT, M10-8-B HEX NYLON ZINC LOCK	F81033-1	16
8	WASHER, 10.5 FLAT ZINC	F81055-1	40
	FOOT, COMPLETE	504097	2
9	PLATE, M10 RETAINING	101242-1	2
10	FOOT, OUTRIGGER	504098-1	1
11	BOLT, M10X25-8.8-FE/ZN5	F81003-11	4
12	BOLT, M10 X 70-8.8 Fe/Zn5, PN-M/82105	F81003-20	2
13	NUT, M10-8-B-FE	F81033-3	2
14	WASHER, 10.5 FLAT ZINC	F81055-1	6



4.12 Mast & Tilt Adjustment Assembly

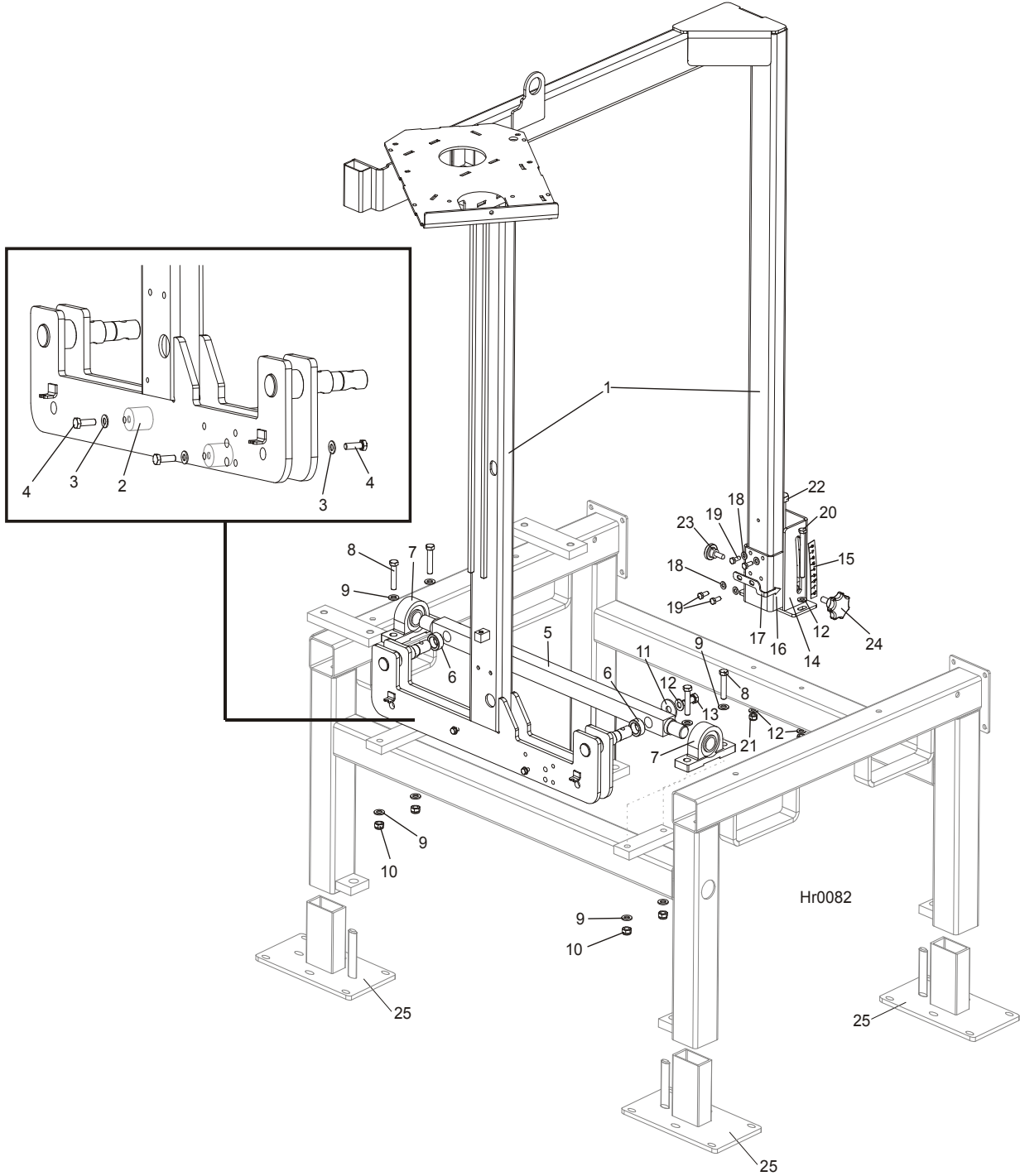

REF	DESCRIPTION (◆ Indicates Parts Available In Assemblies Only)	PART #	QTY.
1	<b>MAST, HR115 WELDED/ PAINTED</b>	505061-1	1
	<b>HR115 MAST FOOT</b>	096720	1
2	ROD, MAST FOOT	503401	2
3	WASHER, 8.4 FLAT ZINC	F81054-1	4
4	BOLT, M8X25-8.8-B HEX HEAD FULL THREAD ZINC	F81002-5	4
5	<b>BAR, HR110/115 MAST SUPPORT</b>	503771-1	1

# 4

## SAW HEAD & FEED TRACK

### *Mast & Tilt Adjustment Assembly*

6	BUSHING, 38/25.4X16	503967-1	2	
7	BEARING, UCP 206 CX W/HOUSING	099254	2	
8	BOLT, M12X60-8.8 HEX HEAD ZINC	F81004-5	4	
9	WASHER, 13 FLAT ZINC	F81056-1	8	
10	NUT, M12-8 HEX NYLON ZINC LOCK	F81034-2	4	
11	WASHER, 13 SPECIAL FLAT ZINC-PL.	F81056-14	2	
12	WASHER, 10.5 FLAT ZINC	F81055-1	6	
13	BOLT, M10X25-8.8 HEX HEAD FULL THREAD ZINC	F81003-11	2	
14	BRACKET, HR100/115 MAST MOUNT	503989-1	1	
15	DECAL, HR110/115 TILT ANGLE SCALE	504294	1	
16	CONNECTOR, HR110/115 TILT ADJUSTMENT ASSEMBLY	503980-1	1	
17	INDICATOR, HR110/115 TILT ANGLE SCALE	504295-1	1	
18	WASHER, 8.4 FLAT ZINC	F81054-1	4	
19	BOLT, M8X20-8.8 HEX HEAD FULL THREAD ZINC	F81002-4	4	
20	BOLT, M10X110 8.8 HEX HEAD ZINC	F81003-43	2	
21	NUT, M10-8-B NYLON HEX ZINC LOCK	F81033-1	2	
22	BOLT, HR110/115 TILT ANGLE ADJUSTMENT	504868	1	
23	SCREW, M10X25 8.8 KNURLED THUMB ZINC-PL. W/HIGH HEAD	F81003-24	1	
24	KNOB, SR1580 63X25 M12	500460	1	
25	FOOT PLATE ASSEMBLY	512225-1	4	

## SECTION 5 UP/DOWN SYSTEM

### 5.1 Up/Down Crank Assembly

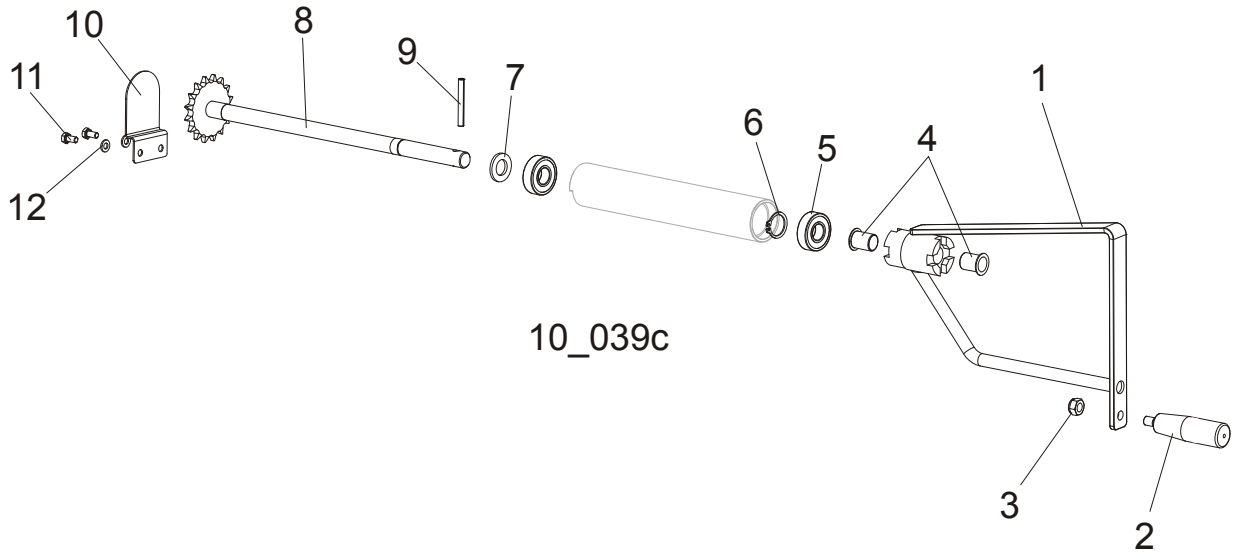

REF	DESCRIPTION (◆ Indicates Parts Available In Assemblies Only)	Part #	Qty.
	<b>FEED CRANK COMPLETE</b>	502967	1
1	CRANK, WELDMENT LT105	086120-1	1
2	NOB, 12992M10 PLASTIC CRANK HANDLE	086338	1
3	NUT, M10-8-B HEX NYLON ZINC LOCK	F81033-1	1
4	BUSHING, GFM-1719-25	094142	2
5	BEARING, 6203-2RS	086114	2
6	RING, Z 17 OUTSIDE RETAINING	F81090-21	1
7	WASHER, 17 FLAT ZINC	F81058-1	1
8	SHAFT W/SPROCKET LT10	097242-1	1
9	PIN, 6X50 ZINC ROLL	F81045-1	1
10	GUARD, UPPER LT10 SAW HEAD SPROCKET	092567-1	1
11	BOLT, M6X12-8.8 HEX HEAD FULL THREAD ZINC	F81001-7	2
12	WASHER, 6.4 FLAT ZINC	F81053-1	2

**5.2 Up/Down Drive Sprocket Assembly**

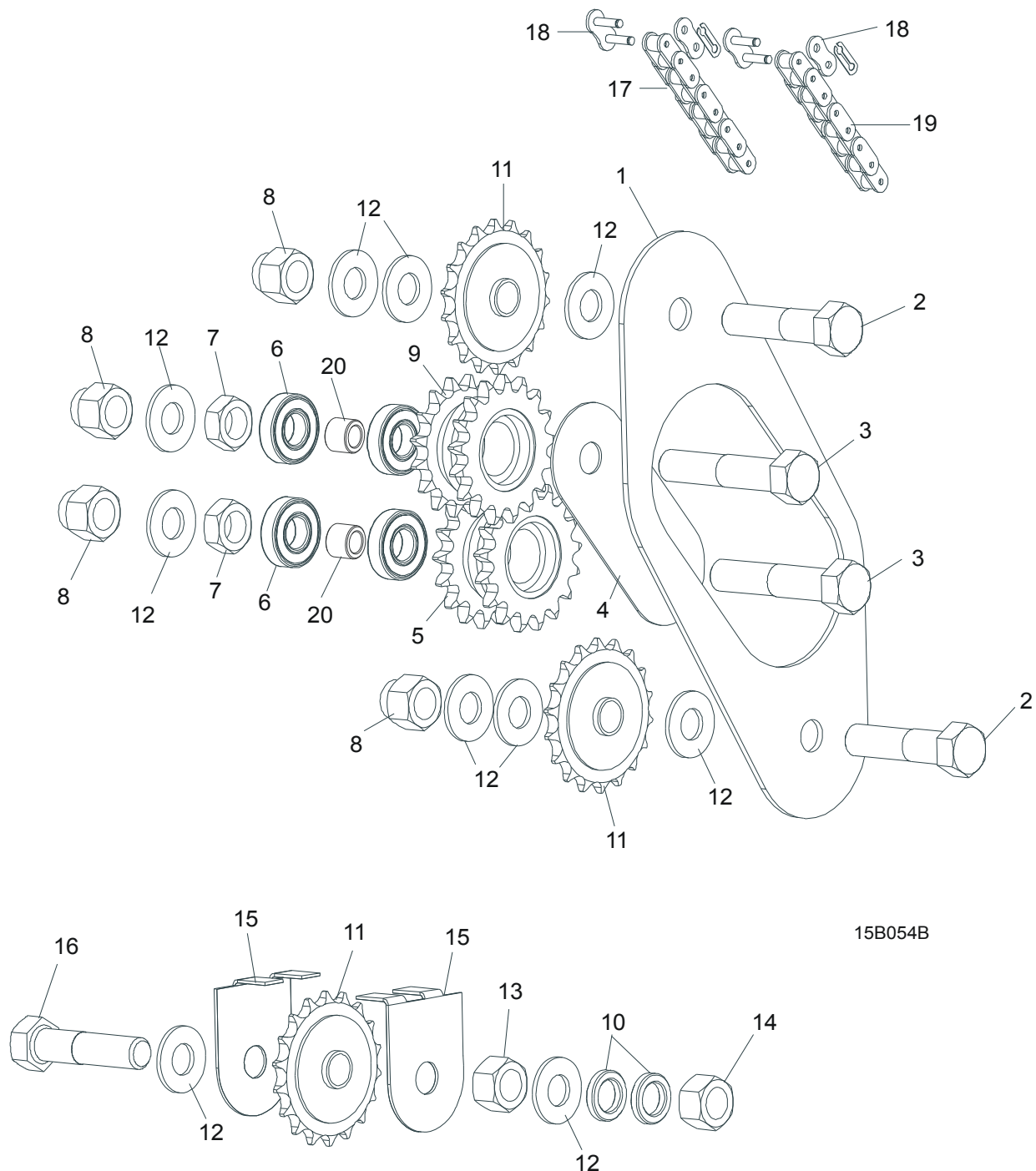

REF	DESCRIPTION (◆ Indicates Parts Available In Assemblies Only)	Part #	Qty.
1	GUARD, UP/DOWN CHAIN INTERNAL LT10	014907	1
2	BOLT, M16X65-8.8-B HEX HEAD FULL THREAD ZINC	F81006-1	2
3	BOLT, M16X80 8.8-B HEX HEAD FULL THREAD ZINC	F81006-11	2
4	PLATE, UP/DOWN DRIVE SPROCKET MOUNT PTD	087104-1	1

5	SPROCKET DUAL 17/17 PTD	086812-1	1	
6	BEARING, R-10	P04156	4	
7	NUT, M16 HEX THIN ZINC	F81036-4	2	
8	NUT, M16-8 HEX NYLON ZINC LOCK	F81036-2	4	
9	SPROCKET DUAL 16/17 PTD	086813-1	1	
10	WASHER, 41/64"X 1"X 3/16 SPACER	S12480	3	
11	SPROCKET, 17T G1#40-41 5/8" ID	P04333	3	
12	WASHER 17 FLAT ZINC	F81058-1	12	
13	NUT M16-5.8 HEX ZINC	F81036-1	1	
14	NUT, M16-8 HEX NYLON ZINC LOCK	F81036-2	1	
15	GUARD,LT10 UP/DOWN CHAIN SPROCKET	092566-1	2	
16	BOLT, M16X75-8.8-B HEX HEAD FULL THREAD ZINC	F81006-10	1	
17	CHAIN, #40 X 111 1/2"	014831	1	
18	LINK, #40 MASTER	P04200	2	
19	CHAIN, #40 X 15 1/2"	P12496	1	
20	BUSHING - ZINC	095938-1	2	

**5.3 Slide Pads And Blade Height Scale**

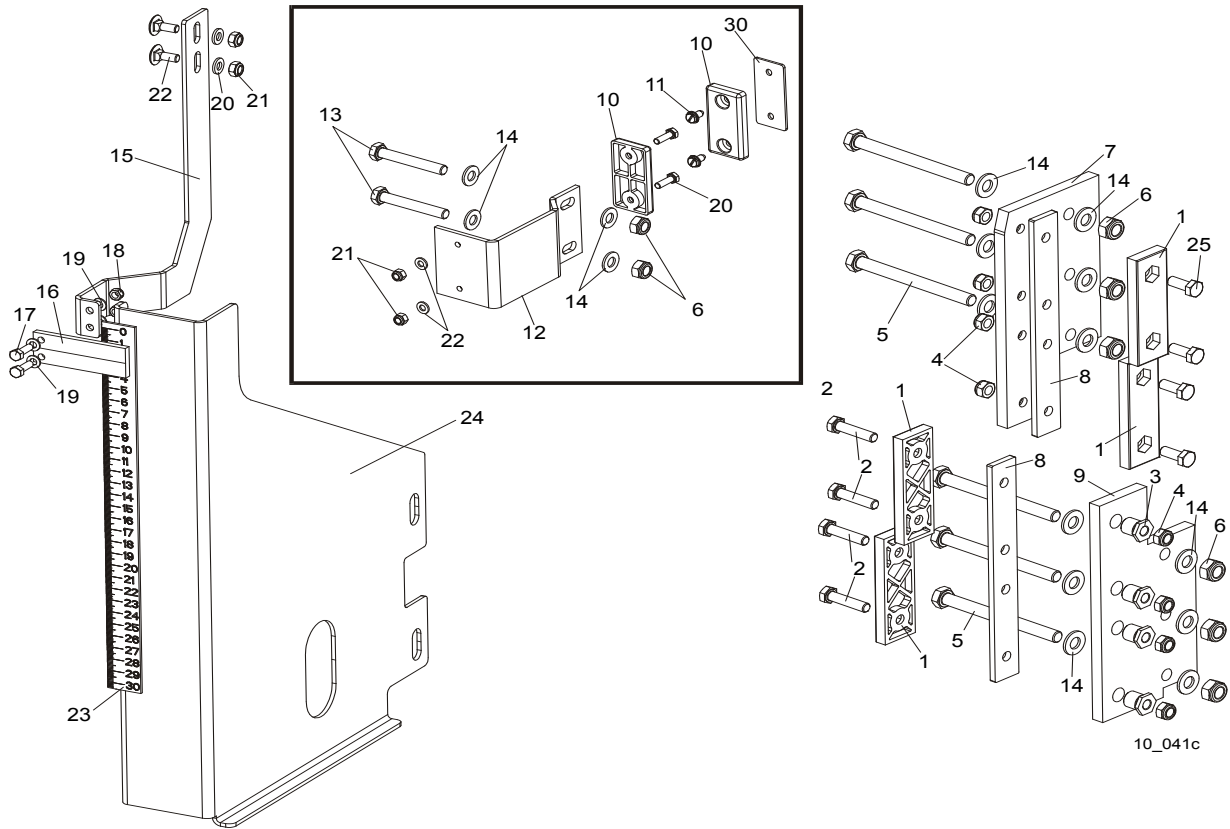

REF	DESCRIPTION (◆ Indicates Parts Available In Assemblies Only)	Part #	Qty.
1	PADS, UP/DOWN SLIDE	M04096	4
2	BOLT, M8X35 -8.8 HEX HEAD FULL THREAD ZINC	F81002-13	4
3	NUT, LT10 SLIDE PAD ADJUSTMENT ZINC-PLATED	086683-1	4
4	NUT, M8-8-B HEX NYLON ZINC LOCK	F81032-2	8
5	BOLT, M10X110 8.8 HEX HEAD ZINC	F81003-43	6
6	NUT, M10-8-B HEX NYLON ZINC LOCK	F81033-1	8
7	PLATE, LT10 SLIDE PAD MOUNT	094139-1	1
8	BACKING, MAST SLIDE PADS	094140-1	2
9	PLATE, SLIDE PAD MOUNT	086682-1	1
10	PAD, CATERPILLAR TRACK	P13576	2
11	BOLT, 1/4-20 X 1/2"SELF TAP HEX HEAD	F05015-1	2
12	BRACKET, LT10MAST GUIDE IDLE SIDE PAINTED	087192-1	1
13	BOLT, M10X70-8.8 HEX HEAD FULL THREAD ZINC	F81003-20	2
14	WASHER, 10.5 FLAT ZINC	F81055-1	16
	INDICATOR, BLADE HEIGHT COMPLETE HR110	<b>504541</b>	<b>1</b>
15	BRACKET, LT10 BLADE HEIGHT SCALE MOUNT	504542-1	1
16	Indicator, Blade Height Scale	094821	1

17	Bolt, M5x16 -8.8 Hex Head Full Thread Zinc	F81000-20	2	
18	NUT, M5-8-Fe/Zn5 DIN985	F81030-2	2	
19	WASHER, 5.3 FLAT ZINC	F81052-1	4	
20	WASHER, 6.4 FLAT ZINC	F81053-1	2	
21	NUT, M6-8-B HEX NYLON ZINC LOCK	F81031-2	2	
22	BOLT M6x16 -8.8- Fe/Zn5 PN/M-82406	F81001-36	2	
23	<b>BLADE HEIGHT SCALE HR115</b>	504127	1	
24	<b>BRACKET WLDMT, HEIGHT SCALE MOUNTING PTD</b>	504540-1	1	
25	<b>BOLT, M8X20MM, HEX HEAD,GR 5.8 ZINC</b>	F81002-4	4	