

# **Wood-Mizer®**

## **Replacement Parts Manual**

---

**HR110**

**rev.A2.02**

---



**Safety is our #1 concern!** Read and understand all safety information and instructions before operating, setting up or maintaining this machine.

*September 2010*

*Form #927*

<b>SECTION 1</b>	<b>GENERAL INFORMATION</b>	<b>1-1</b>
1.1	How To Use The Parts List.....	1-1
1.2	Sample Assembly.....	1-1
<b>SECTION 2</b>	<b>BLADE GUIDE ROLLERS &amp; ARM</b>	<b>2-1</b>
2.1	Blade Guide Assembly, Idle Side .....	2-1
2.2	Blade Guide Assembly, Drive Side .....	2-2
2.3	Blade Guide Roller Guards.....	2-3
<b>SECTION 3</b>	<b>BLADE WHEELS &amp; TENSIONER</b>	<b>3-1</b>
3.1	Blade Wheel Assembly, Drive Side .....	3-1
3.2	Blade Wheel Assembly, Idle Side .....	3-3
3.3	Blade Tensioner Assembly .....	3-5
3.4	Motor Assembly, HR110.....	3-6
3.5	Motor Assembly HR115 .....	3-7
<b>SECTION 4</b>	<b>SAW HEAD &amp; FEED TRACK</b>	<b>4-1</b>
4.1	Blade Housing Cover .....	4-1
4.2	Water Lube Assembly.....	4-3
4.3	Decals, HR110 .....	4-4
4.4	Control Panel, HR110.....	4-6
4.5	Electric Box Decals.....	4-8
4.6	Hold-Down Roller Front.....	4-9
4.7	Hold-Down Roller Rear .....	4-11
4.8	Infeed, Outfeed & Return Tables.....	4-12
4.9	Feed Track Assembly.....	4-13
4.10	Table, Idle Roller .....	4-15
<b>SECTION 5</b>	<b>UP/DOWN SYSTEM</b>	<b>5-1</b>
5.1	Up/Down Crank Assembly .....	5-1
5.2	Up/Down Drive Sprocket Assembly.....	5-2
5.3	Slide Pads And Blade Height Scale .....	5-4



## SECTION 1 GENERAL INFORMATION

### 1.1 How To Use The Parts List

- Use the index above to locate the assembly that contains the part you need.
- Go to the appropriate section and locate the part in the illustration.
- Use the number pointing to the part to locate the correct part number and description in the table.
- Parts shown indented under another part are included with that part.
- Parts marked with a diamond (◆) are only available in the assembly listed above the part.

See the sample table below. Sample Part #A01111 includes part F02222-2 and subassembly A03333. Subassembly A03333 includes part S04444-4 and subassembly K05555. The diamond (◆) indicates that S04444-4 is not available except in subassembly A03333. Subassembly K05555 includes parts M06666 and F07777-77. The diamond (◆) indicates M06666 is not available except in subassembly K05555.

1.2 Sample Assembly				
REF	DESCRIPTION (◆ Indicates Parts Available In Assemblies Only)	PART #	QTY.	
	Sample Assembly, Complete (Includes All Indented Parts Below)	A01111	1	
1	Sample Part	F02222-22	1	
	Sample Subassembly (Includes All Indented Parts Below)	A03333	1	
2	Sample Part (◆ Indicates Part Is Only Available With A03333)	S04444-4	1	◆
	Sample Subassembly (Includes All Indented Parts Below)	K05555	1	
3	Sample Part (◆ Indicates Part Is Only Available With K05555)	M06666	2	◆
4	Sample Part	F07777-77	1	

#### To Order Parts:

- From Europe call our European Headquarters and Manufacturing Facility in Kolo, Poland at **+48-63-2626000**. From the continental U.S., call our toll-free Parts hotline at **1-800-525-8100**. Have your customer number, vehicle identification number, and part numbers ready when you call. From other international locations, contact the Wood-Mizer distributor in your area for parts.

#### Office Hours:

Country	Monday - Friday	Saturday	Sunday
Poland	7-15	Closed	Closed
US	8 a.m.- 5 p.m.	Closed	Closed



**CAUTION!** It is strongly recommended that only original spare parts be used.

## SECTION 2 BLADE GUIDE ROLLERS & ARM

### 2.1 Blade Guide Assembly, Idle Side

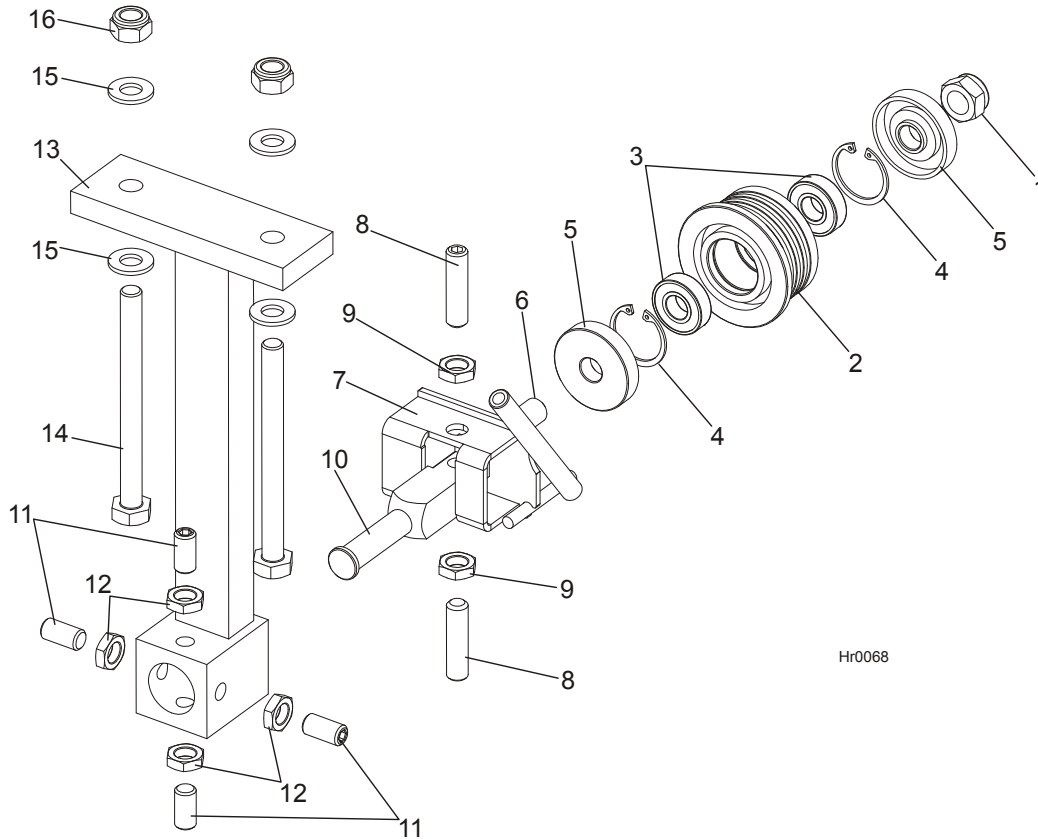

Hr0068

REF	DESCRIPTION (◆ Indicates Parts Available In Assemblies Only)	PART #	QTY.	
	<b>BLADE GUIDE ROLLER, HR115 INVERSION</b>	504863	1	
	BLADE GUIDE ASSEMBLY, IDLE SIDE	505613	1	
	Roller, Blade Guide Complete Standard	087887	1	
1	Nut, M12-8 Hex Nylon Zinc Lock	F81034-2	1	
2	Roller, Blade Guide Narrow	087889	1	◆
3	Bearing, 6001 2RSR FAG	087893	2	
4	Ring, W28 Inside Retaining	F81090-9	1	
5	Washer, Zinc-plated Spacer	087891-1	2	
6	Shaft, Blade Guide Roller Zinc-plated	087763-1	1	
7	Bracket Weldment, Idle Side Blade Guide Painted	094681-1	1	
8	Screw, M10x1x40 DIN 913 A2-70 Set Stainless Steel	F81015-2	2	
9	Nut, M10x1-04-ST-A2 ISO 8675 Thin	F81033-10	2	
10	Shaft, Zinc-plated Blade Guide Mount	088255-1	1	
11	SCREW, M10X1X20 DIN 913 SET STAINLESS STEEL	F81015-1	4	
12	NUT, M10x1-04-ST-A2 ISO 8675 THIN	F81033-10	4	
13	BRACKET, HR115 BLADE GUIGE INVERSION	504860-1	1	
14	BOLT, M10 X 115-8.8 Fe/Zn5, PN-M/82101	F81003-19	2	
15	WASHER, 10.5 FLAT ZINC	F81055-1	4	
16	NUT, M10-8-B HEX NYLON ZINC LOCK	F81033-1	2	

# 2 BLADE GUIDE ROLLERS & ARM

Blade Guide Assembly, Drive Side

## 2.2 Blade Guide Assembly, Drive Side

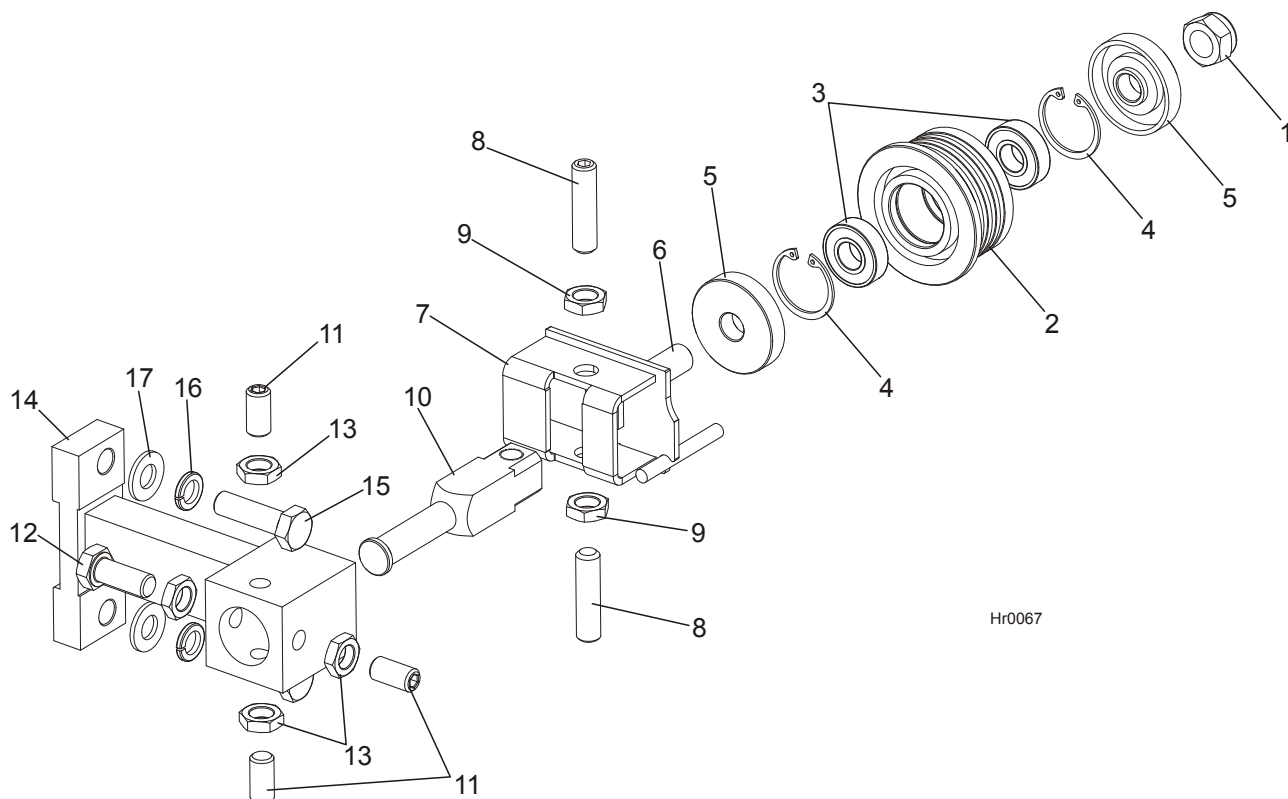

Hr0067

REF	DESCRIPTION (◆ Indicates Parts Available In Assemblies Only)	PART #	QTY.
	<b>BLADE GUIDE ASSEMBLY, DRIVE SIDE</b>	505612	1
	ROLLER, BLADE GUIDE COMPLETE STANDARD	087887	1
1	Nut, M12-8 Hex Nylon Zinc Lock	F81034-2	1
2	Roller, Blade Guide Narrow	087889	1
3	Bearing, 6001 2RSR FAG	087893	2
4	Ring, W28 Inside Retaining	F81090-9	1
5	Washer, Zinc-plated Spacer	087891-1	2
6	Shaft, Blade Guide Roller Zinc-plated	087763-1	1
7	BRACKET WELDMENT, BLADE GUIDE PAINTED	094679-1	1
8	SCREW, M10X1X40 DIN 913 A2-70 SET STAINLESS STEEL	F81015-2	2
9	NUT, M10X1-04-ST-A2 ISO 8675 THIN	F81033-10	2
10	SHAFT, ZINC-PLATED BLADE GUIDE MOUNT	088255-1	1
11	<b>SCREW, M10X1X20 DIN 913 SET STAINLESS STEEL</b>	F81015-1	3
12	<b>BOLT, M10X1X25 DIN 933 STAINLESS STEEL</b>	F81003-28	1
13	<b>NUT, M10x1-04-ST-A2 ISO 8675 THIN</b>	F81033-10	4
14	<b>BRACKET, HR115 BLADE GUIDE DRIVE SIDE</b>	504119-1	1
15	<b>BOLT, M10X35-8.8 HEX HEAD FULL THREAD ZINC</b>	F81003-17	2
16	<b>WASHER, 10.2 SPLIT LOCK ZINC</b>	F81055-2	2
17	<b>WASHER, 10.5 FLAT ZINC</b>	F81055-1	2

### 2.3 Blade Guide Roller Guards

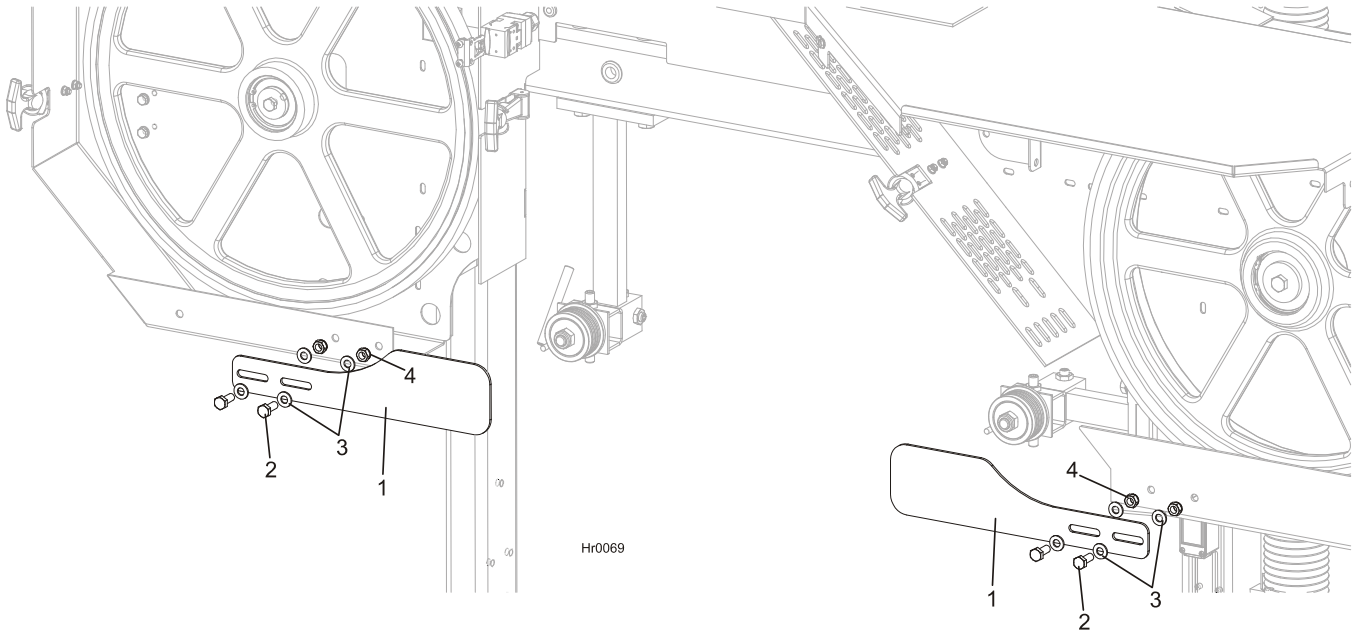

REF	DESCRIPTION (◆ Indicates Parts Available In Assemblies Only)	PART #	QTY.
1	GUARD, HR110/115 BLADE GUIDE ROLLER	504870-1	2
2	BOLT, M8X20MM HH GR 8.8 FULL THRD ZINC	F81002-1	4
3	WASHER, 8.4 FLAT ZINC	F81054-1	8
4	NUT, M8-8-B HEX NYLON LOCK ZINC	F81032-2	4

## SECTION 3 BLADE WHEELS & TENSIONER

### 3.1 Blade Wheel Assembly, Drive Side

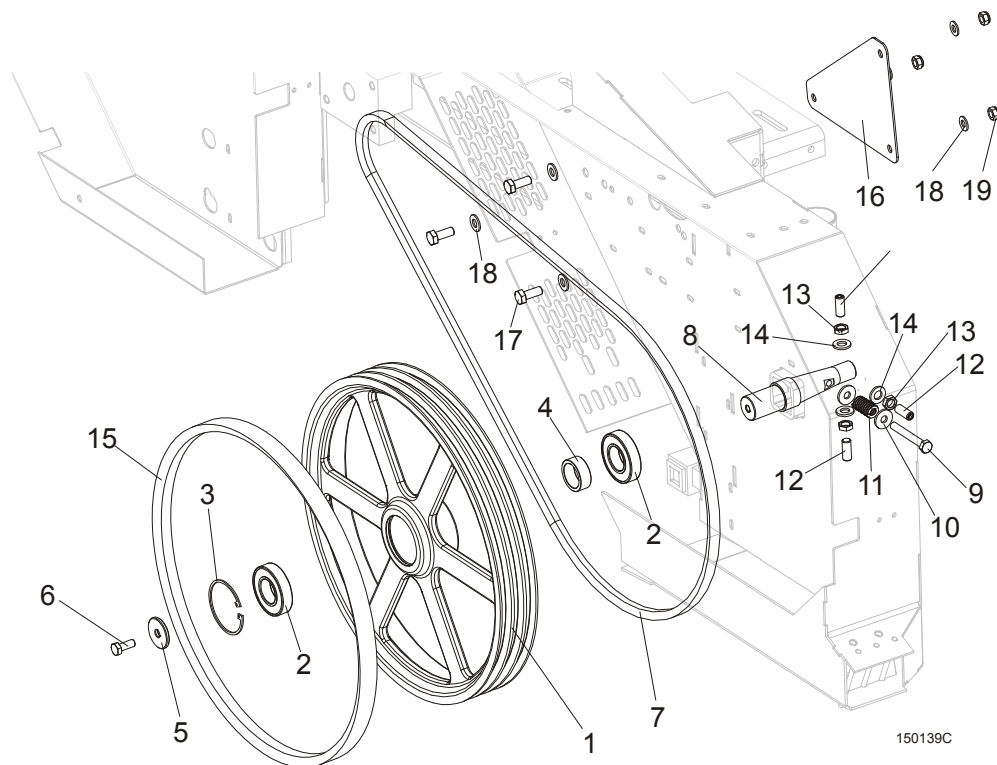

REF	DESCRIPTION (◆ Indicates Parts Available In Assemblies Only)	PART #	QTY.
	<b>BLADE WHEEL ASSEMBLY, LT15 DRIVE SIDE</b>	093849	1
1	WHEEL, LT15 DRIVE SIDE BLADE	014727 <sup>1</sup>	1
2	BEARING, 6207-2RS 35X72X17 FAG	014811 <sup>2</sup>	2
3	RING, 72MM N5002-281 RETAINING	F04254-30	1
4	BUSHING, LT15 BEARING SPACER	093851	1
5	WASHER, LT15 DRIVE SIDE BLADE WHEEL	086286	1
6	BOLT, M10X25-8.8 HEX HEAD FULL THREAD ZINC	F81003-11	1
7	V-BELT, BX81, LT15	014819	1 <sup>3</sup>
8	SHAFT, LT15 DRIVE SIDE BLADE WHEEL	093850	1
9	BOLT, M10X75-8.8 HEX HEAD ZINC	F81003-15	1
10	WASHER, 10.5 SPECIAL FLAT ZINC	F81055-6	2
11	SPRING, 19X38 COMPRESSION	034430	1
12	SCREW, M12X1,25X30 DIN913 SET STAINLESS STEEL	F81016-1	3
13	NUT, M12X1.25 DIN439 THIN STAINLESS STEEL	F81034-9	3
14	WASHER, 13 FLAT ZINC	F81056-1	3
15	V-BELT, B57	P04185-2	1
16	CAP, BOLTED PTD	094247-1	1
17	BOLT, M8X20-5.8 HEX HEAD FULL THREAD ZINC	F81002-1	3
18	WASHER, 8.4 FLAT ZINC	F81054-1	6
19	NUT, M8-8-B HEX NYLON ZINC LOCK	F81032-2	3

<sup>1</sup> LT15 for Russian market is equipped with drive wheel No. 090646-1

<sup>2</sup> LT15 for Russian market is equipped with one bearing 014811 and one 092005 (wide)



<sup>3</sup> LT15 for Russian market is equipped with two belts.

# 3 Blade Wheels & Tensioner

## Blade Wheel Assembly, Idle Side

### 3.2 Blade Wheel Assembly, Idle Side

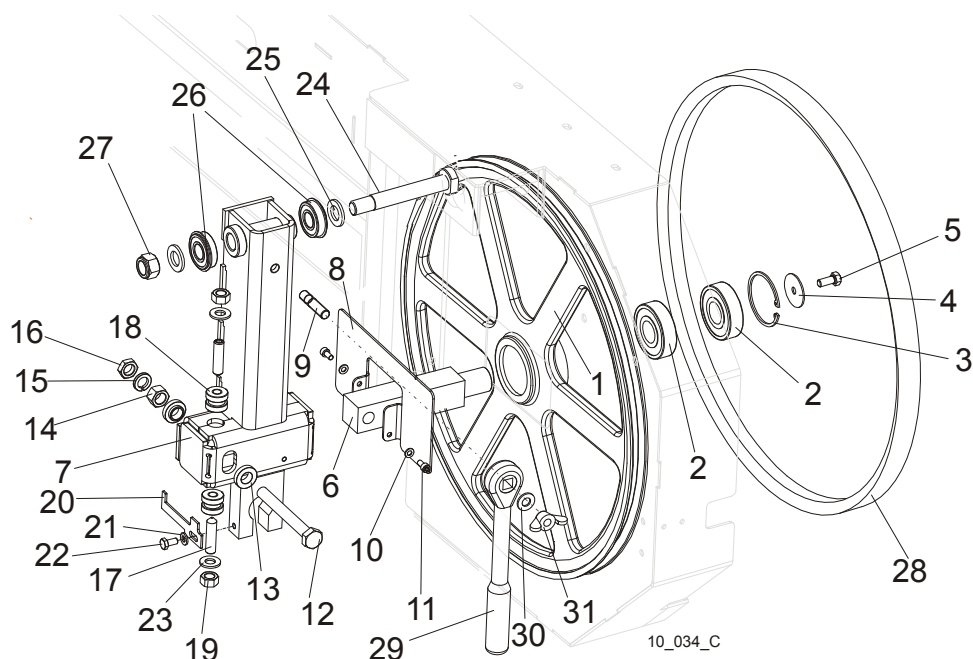

REF	DESCRIPTION (◆ Indicates Parts Available In Assemblies Only)	PART #	QTY.
	<b>WHEEL ASSEMBLY, IDLE SIDE BLADE</b>	<b>A08218</b>	<b>1</b>
1	WHEEL ASSEMBLY, 18.62" BLADE IDLE SIDE	P08125	1
2	BEARING, 6305 2RS NSK IDLE SIDE WHEEL	P08066	2
3	RING, 2 7/16" INSIDE RETAINING	F04254-21	1
	<b>HOUSING, LT10 &amp; LT15 IDLER SHAFT, COMPLETE</b>	<b>100180</b>	<b>1</b>
4	WASHER, IDLE SIDE WHEEL RETAINING	093854-1	1
5	BOLT, M8X25-8.8-B HEX HEAD FULL THREAD ZINC	F81002-5	1
6	SHAFT, IDLE SIDE BLADE WHEEL (METRIC)	096045	1
	<b>HOUSING, IDLER SHAFT COMPLETE</b>	<b>508145</b>	<b>1</b>
7	HOUSING, IDLER SHAFT WELDED/PAINTED	508144-1	1
8	COVER, HOUSING, IDLER SHAFT COMPLETE PAINTED	508128-1	1
9	BOLT M10X35-8.8	F81003-9	1
10	WASHER, 5.3 FLAT ZINC	F81052-1	2
11	SCREW, M5x10 DIN912 A2-70 HEX SOCKET HEAD	F81000-23	2
12	BOLT, M12X1,25X100-8.8 HEX HEAD FULL THREAD ZINC	F81004-41	1
13	WASHER, FLANGED ZINC-PLATED	086769-1	2
14	NUT, M12X1,25 -8 HEX ZINC	F81034-8	1
15	WASHER, 12.2 SPLIT LOCK ZINC	F81056-2	1
16	NUT, M12x1.25 DIN439 THIN STAINLESS STEEL	F81034-5	1
17	SCREW, M10X40-45H CONE POINT HEX SOCKET	F81003-61	2
18	BUSHING, M10 IDLER SHAFT HOUSING	086987	2
19	NUT, M10-8-B HEX HEAD ZINC	F81033-3	2
20	INDICATOR, LT15/LT20 PTD BLADE TENSION	092467-1	1
21	WASHER, 6.4 FLAT ZINC	F81053-1	1
22	BOLT, M6x12-8.8 HEX HEAD FULL THREAD ZIN	F81001-7	1
23	WASHER, 10.5 FLAT ZINC	F81055-1	2

24	PIN, IDLER ARM MOUNT	086404	1	
25	WASHER, 17 FLAT ZINC	F81058-1	2	
26	BEARING, 6203-2RS NR NSK W/SNAP RING	086395	2	
27	NUT, M16-8 HEX NYLON ZINC LOCK	F81036-2	1	
28	V-BELT, B57	P04185-2	1	
29	Wrench, LT20 Blade Tension	091620	1	
30	WASHER, 10.5 FLAT ZINC	F81055-1	1	
31	NUT WING M10	F81033-8	1	

# 3 Blade Wheels & Tensioner

## Blade Tensioner Assembly

### 3.3 Blade Tensioner Assembly

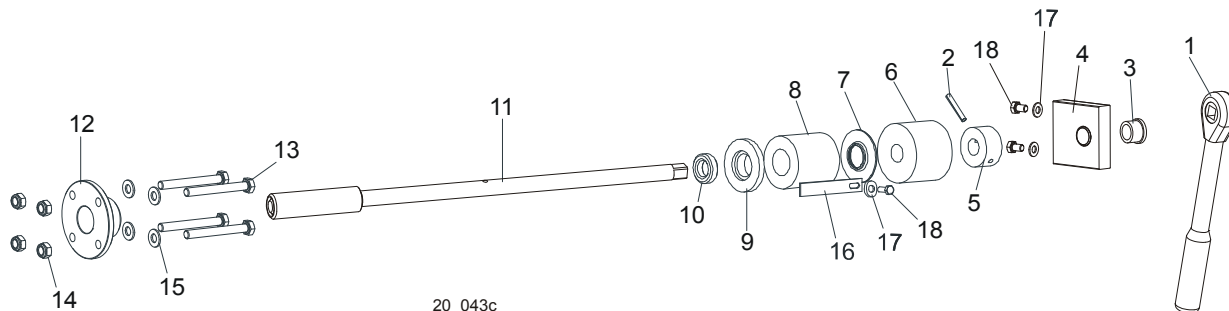

20\_043c

REF	DESCRIPTION (◆ Indicates Parts Available In Assemblies Only)	PART#	QTY.	
	<b>BLADE TENSIONER ASSEMBLY</b>	090587	1	
1	Wrench, LT20 Blade Tension	091620	1	
2	Pin, 5 x 30 Zinc Roll	F81044-21	1	
	Bracket, Tension Handle Mount w/Bushing	096729	1	
3	Bushing GFM-1618-17(IGUS)	089589	1	
4	Bracket, Painted	096730	1	
5	Collar, Blade Tensioner	086712-1	1	
6	Bushing, Rubber Stop	P12165	1	
7	Guide, LT15 Tension Handle	014925	1	
8	Spring, LT15 Rubber Blade Tensioner	014828	1	
9	Washer, Rubber Spring Front	086674-1	1	
10	Bearing, 51103 FLT Ball Thrust	086675	1	
11	Shaft Weldment, Blade Tensioner Zinc-plated	101338-1	1	
12	Nut, Blade Tensioner	086672-1	1	
13	Bolt, M8x70 8.8 Hex Head Zinc	F81002-71	4	
14	Nut, M8-8-B Hex Nylon Zinc Lock	F81032-2	4	
15	Washer, 8.4 Zinc Flat	F81054-1	8	
16	Indicator, LT15 Blade Tension Zinc-plated	092467-1	1	
17	Washer, 6.4 Zinc Flat	F81053-1	1	
18	Bolt, M6x16 8.8 Hex Head Full Thread Zinc	F81001-15	1	

### 3.4 Motor Assembly, HR110

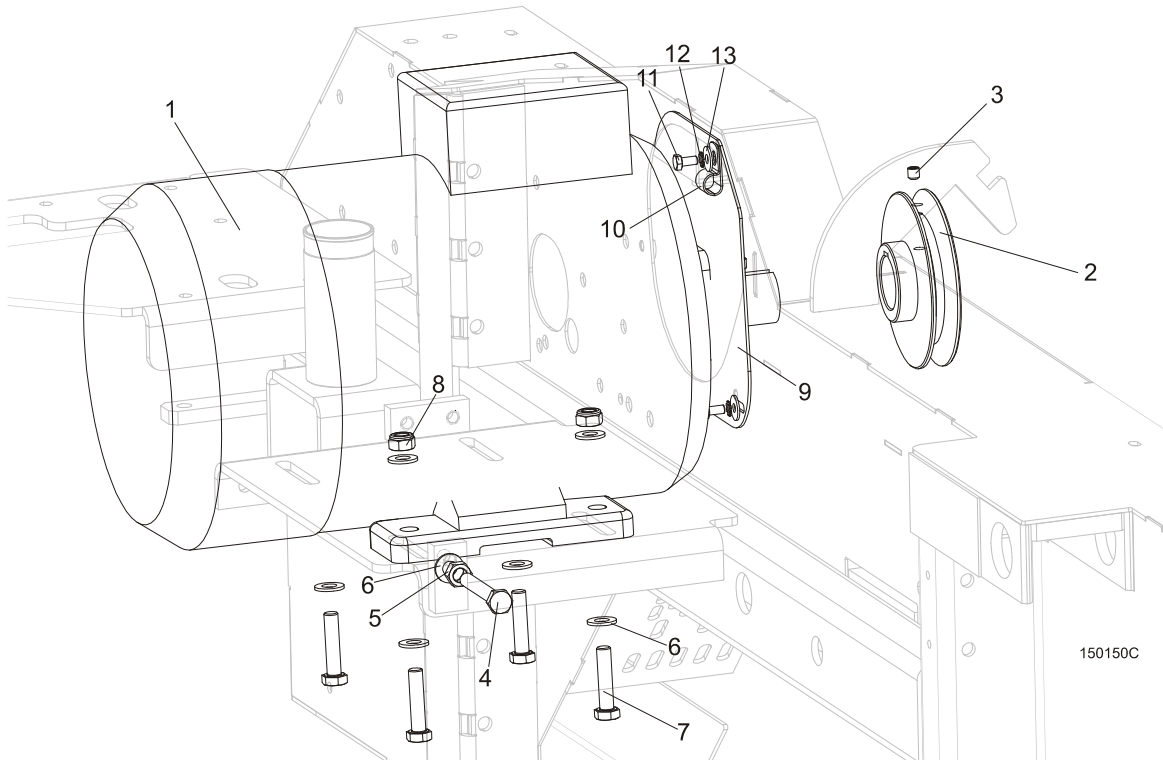

REF	DESCRIPTION (◆ Indicates Parts Available In Assemblies Only)	PART #	QTY.	
1	MOTOR, 5.5kW 400V 1LE1002 1CA03-4AA0 ELECTRIC	095785	1	
2	PULLEY, LT15 E11 MOTOR ZINC-PLATED	086807-1	1	
3	SCREW, M8X8-33H HEX SOCKET SET FLAT POINT ZINC	F81014-1	1	
4	BOLT, M10X80-8.8 HEX HEAD FULL THREAD ZINC	F81003-76	2	
5	NUT, M10-8-B HEX ZINC	F81033-3	2	
6	WASHER, 10.5 FLAT ZINC	F81055-1	10	
7	BOLT, M10X45-8.8 HEX HEAD FULL THREAD ZINC	F81003-3	4	
8	NUT, M10-8-B HEX NYLON ZINC LOCK	F81033-1	4	
9	MOTOR SHAFT COVER, PAINTED, E11/E15	095335-1	1	
10	CLAMP, 1/2" EMT COATED	010748	1	
11	BOLT M6X12-8.8-FE/ZN5	F81001-7	3	
12	WASHER, 6.4 EXTERIOR STAR LOCK ZINC	F81053-2	3	
13	WASHER, 6.5 SPECIAL FLAT ZINC	F81053-11	3	

### 3.5 Motor Assembly HR115

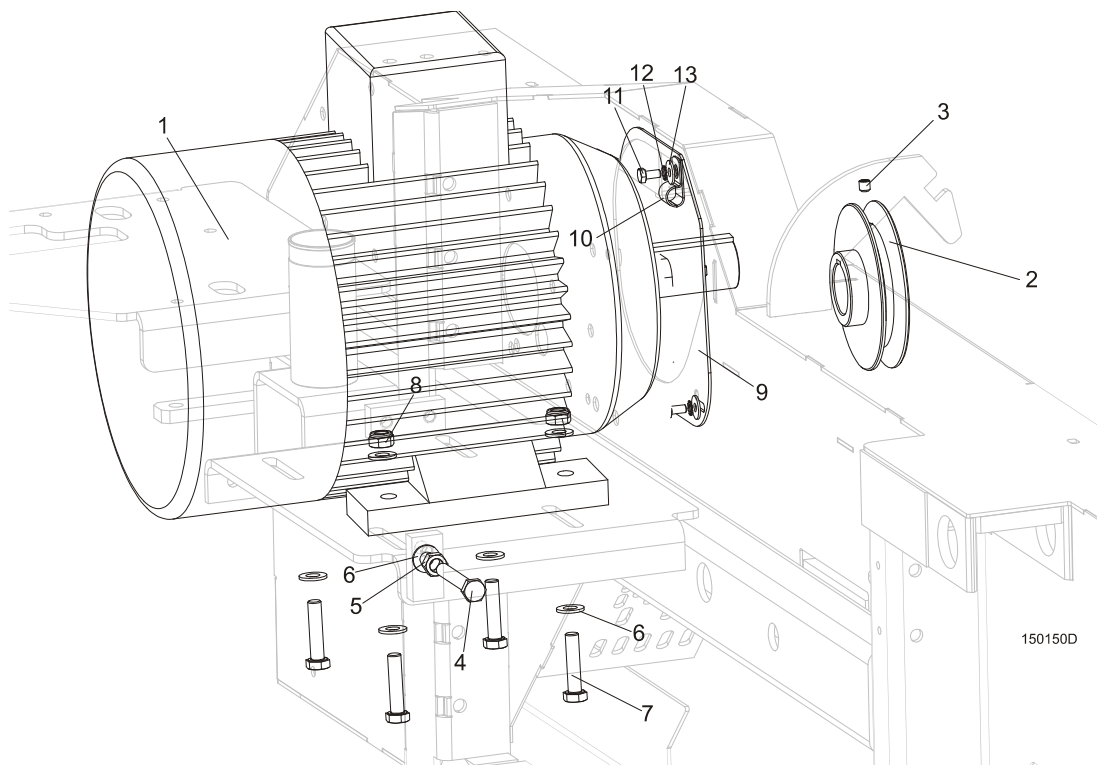

REF	DESCRIPTION (◆ Indicates Parts Available In Assemblies Only)	PART #	QTY.
1	MOTOR, SILNIK Sg132S-2B-HM 400V CE(E11)	090993	1
	MOTOR (7.5KW)11KM 1LA7131-2AA6, 400V (E11)	085482	1
	MOTOR SG132S-2PC, 400 V CE (E15)	089049	1
	MOTOR, ELECTRIC, 11KW,3-PHASE, 400V (PL) (E15)	P85186	1
	MOTOR, ELECTRIC, 11KW,3-PHASE, 400V FOR HR115EH15-1 EC(PL) (E15)	P85186	1
2	PULLEY, LT15 E11 MOTOR ZINC-PLATED (FOR E11 MOTORS)	086807-1	1
	PULLEY, E15 2-GROOVE (FOR E15 MOTORS)	091560	1
3	SCREW, M8X8-33H HEX SOCKET SET FLAT POINT ZINC	F81014-1	1
4	BOLT, M10X80-8.8 HEX HEAD FULL THREAD ZINC	F81003-76	2
5	NUT, M10-8-B HEX ZINC	F81033-3	2
6	WASHER, 10.5 FLAT ZINC	F81055-1	10
7	BOLT, M10X45-8.8 HEX HEAD FULL THREAD ZINC	F81003-3	4
8	NUT, M10-8-B HEX NYLON ZINC LOCK	F81033-1	4
9	MOTOR SHAFT COVER, PAINTED, E11, E15	086787	1
10	CLAMP, 1/2" EMT COATED	P07584	1
11	BOLT M6X12-8.8-FE/ZN5	F81001-7	3
12	WASHER, M6, STAR, LOCK, ZINC	F81053-2	3
13	WASHER, 6,5 POW.FE/ZN5 EXT	F81053-11	3

## SECTION 4 SAW HEAD & FEED TRACK

### 4.1 Blade Housing Cover

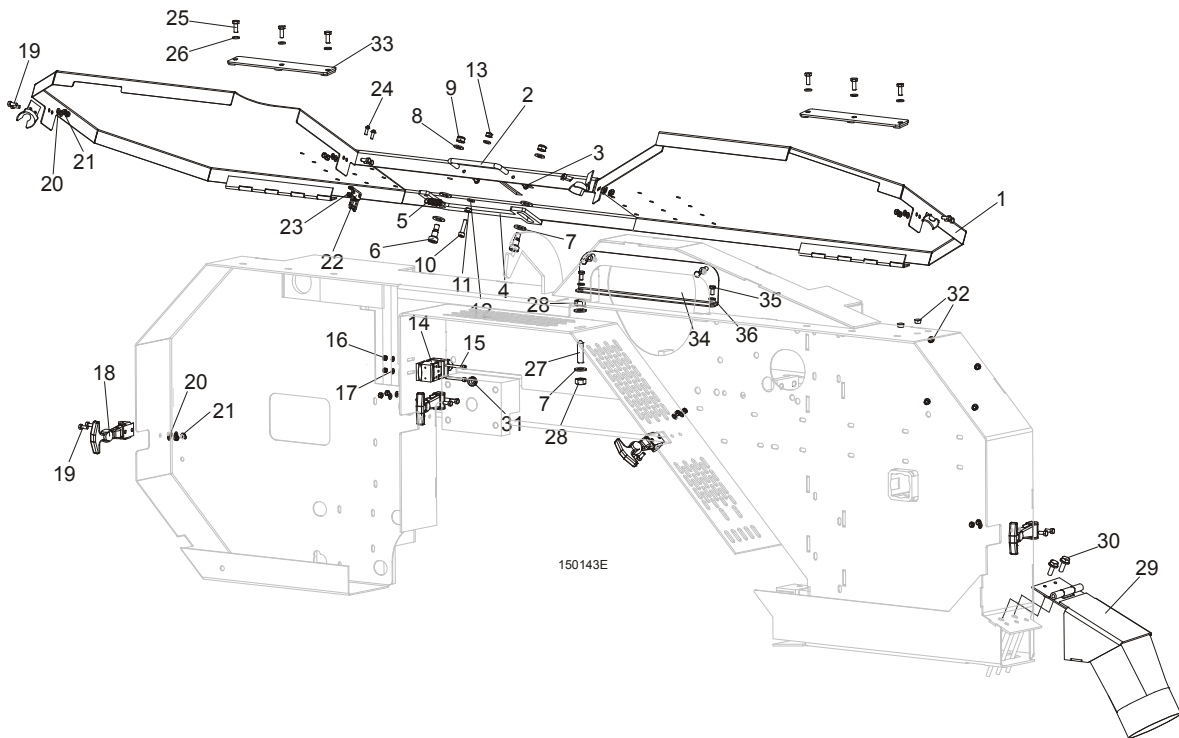

REF	DESCRIPTION (◆ Indicates Parts Available In Assemblies Only)	PART #	QTY.
	<b>COVER, LT15 FRONT COMPLETE</b>	098678	1
1	Cover Weldment, LT10/15/20 Blade Housing Painted	096776-1	1
2	Handle w/Bolt	P08065	1
3	Screw, #8-32x3/8 Self-tapping	F05015-8	2
4	Pawl, Locking Painted	090643-1	1
5	Spring, 1.6x12x38 Extension	092208	1
6	Bolt, 10/M8x12-12.9 ISO-7379 Shoulder	F81003-62	2
7	Washer, 10.5 Flat Zinc	F81055-1	4
8	Washer, 8.4 Flat Zinc	F81054-1	2
9	Nut, M8-8-B Hex Nylon Zinc Lock	F81032-2	2
10	Screw, M6x25-8.8 Hex Socket Head Cap Zinc	F81001-41	1
11	Nut, M6-8 Hex Zinc	F81031-1	1
12	Washer, 6.4 Flat Zinc	F81053-1	2
13	Nut, M6-8-B Hex Nylon Zinc Lock	F81031-2	1
14	<b>SWITCH, AZ17-11ZRK SAFETY</b>	094232	1
15	<b>SCREW, M4X35-8.8 HEX SOCKET HEAD CAP ZINC</b>	F81011-34	2
16	<b>NUT, M4-B HEX NYLON ZINC LOCK</b>	F81029-1	2
17	<b>WASHER, 4.3 FLAT ZINC</b>	F81051-2	2
18	<b>LATCH, FLEXIBLE DRAW</b>	014829	4

## 4

**SAW HEAD & FEED TRACK***Blade Housing Cover*

19	BOLT, M5X12-5.8 HEX HEAD FULL THREAD ZINC	F81000-5	8	
20	WASHER, 5.3 FLAT ZINC	F81052-1	8	
21	NUT, M5-8 DIN 985 ZINC-PLATED	F81030-2	8	
22	KEY, A217/170-B5 SAFETY SWITCH	094422	1	
23	NUT, M4-B HEX NYLON ZINC LOCK	F81029-1	2	
24	SCREW, M4X12-5.8-B CROSS RECESSED PAN HEAD ZINC	F81011-43	2	
25	BOLT, M6X16 8.8 HEX HEAD FULL THREAD ZINC	F81001-15	6	
26	WASHER, 6.4 FLAT ZINC	F81053-1	6	
27	SCREW, M10X40-45H HEX SOCKET SET CONE POINT ZINC	F81003-61	1	
28	NUT, M10-8-B HEX ZINC	F81033-3	2	
29	CHUTE, LT10/15/20 SAWDUST	100903-1	1	
30	BOLT, M8X16-8.8-B HEX HEAD FULL THREAD ZINC	F81002-20	2	
31	GROMMET, 22mm DIA. RUBBER	087400	1	
32	PLUG, SR1086-9,5	096846	6	
33	PLATE, COVER MOUNT	086701-1	2	
34	COVER, SAW HEAD MOUNT	096788-1	1	
35	BOLT, M6X12MM HEX HEAD ZINC	F81001-7	4	
36	WASHER, M6 FLAT ZINC	F81053-1	4	



## 4.2 Water Lube Assembly

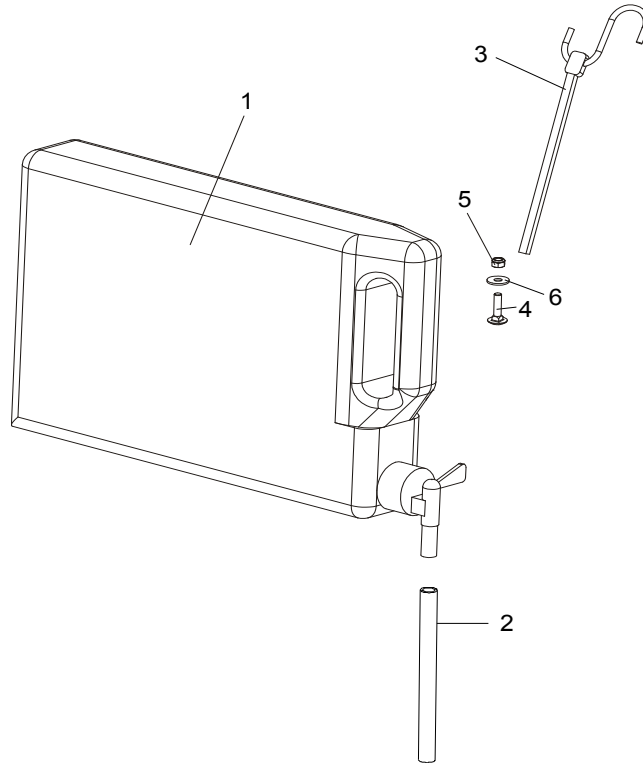

REF	DESCRIPTION (◆ Indicates Parts Available In Assemblies Only)	Part #	Qty.
1	Bottle, 5-liter Water	049119	1
2	Tube, 3/8" I.D. Water Lube	R01885	1,7 m
3	Strap, 24" Rubber w/Hook	P11258	2
4	Bolt, M6x25-8.8 Mushroom Head Square Neck Zinc	F81001-20	1
5	Nut, M6-8-B Hex Nylon Zinc Lock	F81031-2	1
6	Washer, 6.5 Special Flat Zinc	F81053-11	1

# 4 SAW HEAD & FEED TRACK

## Decals, HR110

### 4.3 Decals, HR110

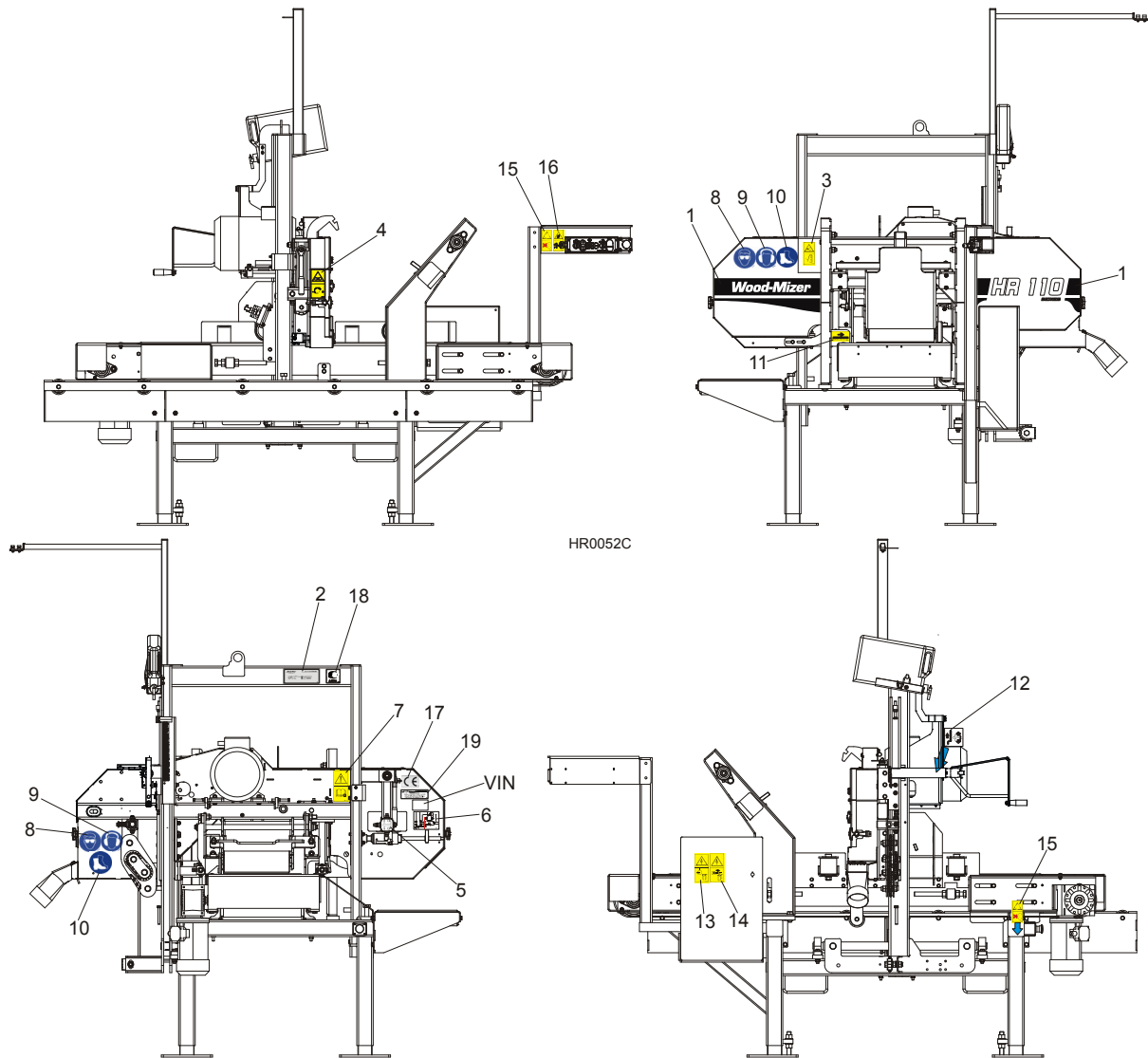

REF	DESCRIPTION (◆ Indicates Parts Available In Assemblies Only)	Part #	Qty.
	<b>PICTOGRAPHIC DECAL KIT, HR110</b>	504240	1
1	DECAL, HR110 SAWMILL NAME	504239	1
2	DECAL, EUROPEAN HEADQUARTERS ADDRESS	015841	1
3	DECAL, SAWMILL COVERS CAUTION	099220	1
4	DECAL, BLADE TENSION (PICTOGRAM)	099219	1
5	DECAL, BLADE ALIGNMENT	P11789	1
6	DECAL, BLADE TENSION INDICATOR ADJUSTMENT	092597	1
7	DECAL, READ OPERATOR'S MANUAL (PICTOGRAM)	096317	1
8	DECAL, EYE PROTECTION WARNING (PICTOGRAM)	S12004G	2
9	DECAL, EAR PROTECTION WARNING (PICTOGRAM)	S12005G	2
10	DECAL, USE SAFETY BOOTS (PICTOGRAM)	501465	2
11	DECAL, BLADE MOVEMENT DIRECTION (PICTOGRAM)	096321	1

## SAW HEAD & FEED TRACK

*Decals, HR110*

**4**

12	DECAL, POWER FEED SYSTEM ENGAGEMENT (PICTOGRAM)	099226	1	
13	DECAL, HIGH VOLTAGE INSIDE THE ELECTRIC BOX (PICTOGRAM)	096316	1	
14	DECAL, REMOVE THE PLUG BEFORE OPENING THE BOX (PICTOGRAM)	096319	1	
15	DECAL, GEAR CAUTION	099540	2	
16	DECAL, KEEP A SAFE DISTANCE AWAY	099221	1	
17	DECAL, CE CERTIFIED SAWMILL (SMALL)	P85070	1	
18	DECAL, RUSSIAN SAFETY CERTIFICATION	099401	1	
19	DECAL, INTERNATIONAL SAWMILL NAME	501466	1	
20	DECAL, MOTOR DIRECTION	S20097	1	
21	DECAL, BLADE SETTING	P85066	1	

## 4.4 Control Panel, HR110

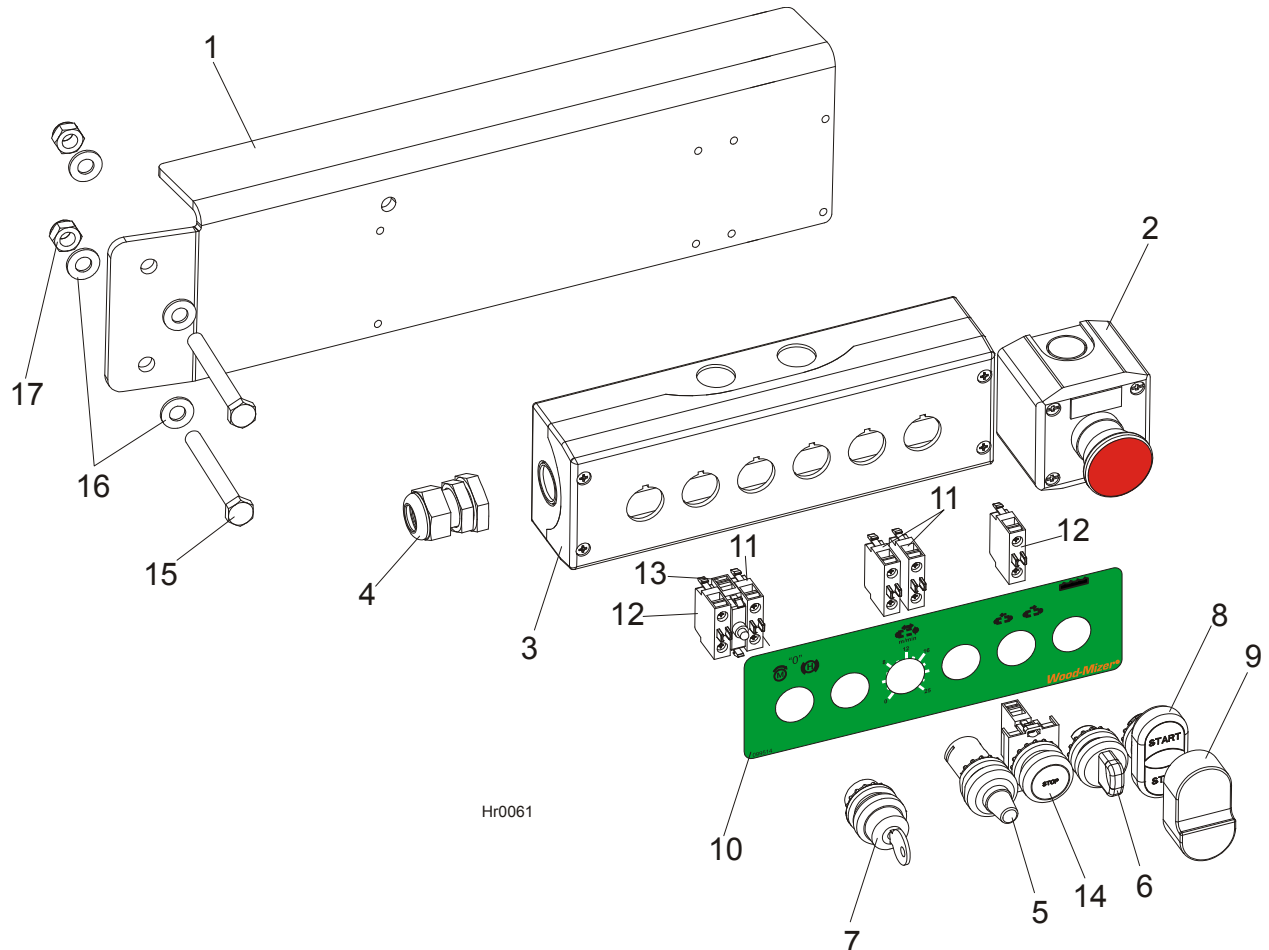

REF	DESCRIPTION (◆ Indicates Parts Available in Assemblies Only)	PART #	QTY.
1	BRACKET, HR115 CONTROL PANEL	505062-1	1
2	SWITCH, XALJ174F EMERGENCY	E22703-P	1
	CONTROL BOX, HR110	503970	1
3	Box, M22-I6 (216540) Control	093750	1
4	Connector, DP 16/H	F81096-7	1
5	Potentiometer, M22-R1K (229489)	093749	1
6	Switch, M22 - 3 Position	091360	1
7	Operator, M22-WRS3 Key Switch	095001	1
8	Operator, M22-DDI-GR-GB1/GB0 Switch	094997	1
9	Membrane M22-T-DD	090462	1
10	Decal, HR130 Control Panel	503969	1
11	Contact Element, M22-KC10	094314	4
12	Contact Element, M22-KC01	094998	2

# SAW HEAD & FEED TRACK

*Control Panel, HR110*

**4**

13	LED Element, M22-LEDC-W	094999	1	
14	Button, M22 STOP	090926	1	
15	<b>BOLT, M10X90-8.8-B HEX HEAD ZINC</b>	F81003-66	2	
16	<b>WASHER, 10.5 FLAT ZINC</b>	F81055-1	4	
17	<b>NUT, M10-8-B HEX NYLON ZINC LOCK</b>	F81033-1	2	

# 4 SAW HEAD & FEED TRACK

*Electric Box Decals*

## 4.5 Electric Box Decals

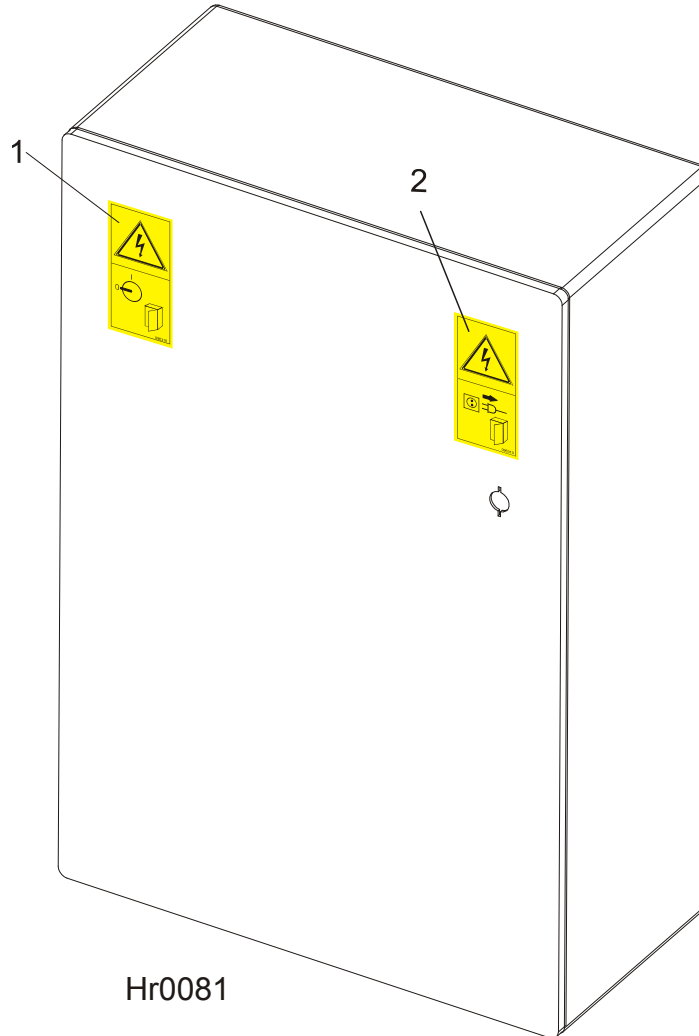

REF	DESCRIPTION (◆ Indicates Parts Available In Assemblies Only)	PART #	QTY.	
	<b>ELECTRIC BOX</b>	503787	1	
1	<b>DECAL, HIGH VOLTAGE INSIDE THE ELECTRIC BOX (PICTOGRAM)</b>	096316	1	
2	<b>DECAL, REMOVE THE PLUG BEFORE OPENING THE BOX (PICTOGRAM)</b>	096319	1	

4.6 Hold-Down Roller Front

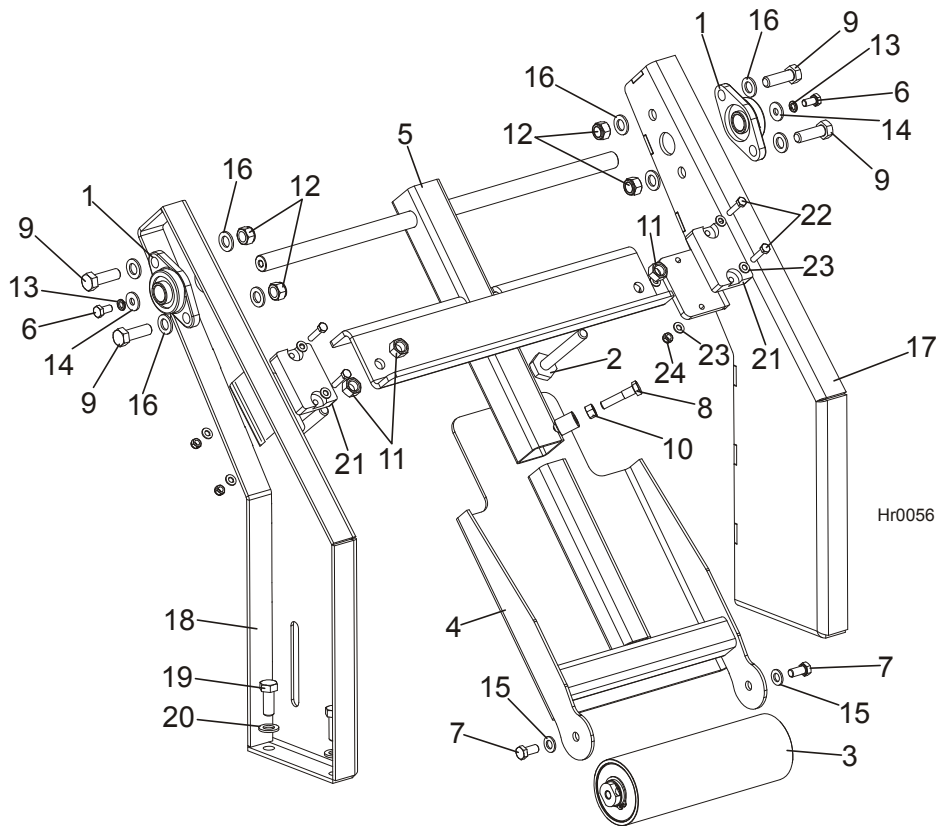

REF	DESCRIPTION (◆ Indicates Parts Available In Assemblies Only)	PART #	QTY.
	<b>ROLLER, HR110/115 HOLD-DOWN FRONT</b>	504526	1
1	BEARING, UCFL 205	089124	2
2	BOLT, M16 ROLLER SUPPORT ZINC	100426-1	2
3	ROLLER, HR110/115 HOLD-DOWN	504130	1
4	BRACKET, HOLD-DOWN ROLLER LOWER	504481-1	1
5	BRACKET, HOLD-DOWN ROLLER UPPER	504483-1	1
6	BOLT, M10X20MM, HEX HEAD, GR 5.8 ZINC	F81003-1	2
7	SCREW, M12X25-8.8-FE/ZN5 PN-M/82105	F81004-31	2
8	BOLT, M12x55 HEX HEAD, GR 5.8 ZINC	F81004-43	1
9	BOLT, M16 X 50-8.8 HEX HEAD	F81006-7	4
10	NUT, M12-8-B ZINC HEX	F81034-1	1
11	NUT, M16-5.8 HEX ZINC	F81036-1	4
12	NUT, M16 HEX NYLON ZINC LOCK	F81036-2	4
13	WASHER, 10.2 SPLIT LOCK ZINC	F81055-2	2
14	WASHER, 10.5 ZINC FLAT SPECIAL	F81055-6	2
15	WASHER, 13 FLAT ZINC	F81056-1	2
16	WASHER, 17 FLAT ZINC	F81058-1	8
17	<b>BRACKET, HOLD-DOWN ROLLER RIGHT</b>	504492-1	1

**4****SAW HEAD & FEED TRACK***Hold-Down Roller Front*

---

18	BRACKET, HOLD-DOWN ROLLER LEFT	504493-1	1	
19	BOLT, M16X40-8.8 HEX HEAD FULL THREAD ZINC	F81006-13	4	
20	WASHER, 17 FLAT ZINC	F81058-1	4	
21	BUMPER, GRENE 70 3201 0010. SHR RUBBER	094969	2	
22	BOLT, M8X35-8.8 HEX HEAD FULL THREAD ZINC	F81002-13	4	
23	WASHER, 8.4 FLAT ZINC	F81054-1	8	
24	NUT, M8-8-B HEX NYLON ZINC LOCK	F81032-2	4	



4.7 Hold-Down Roller Rear

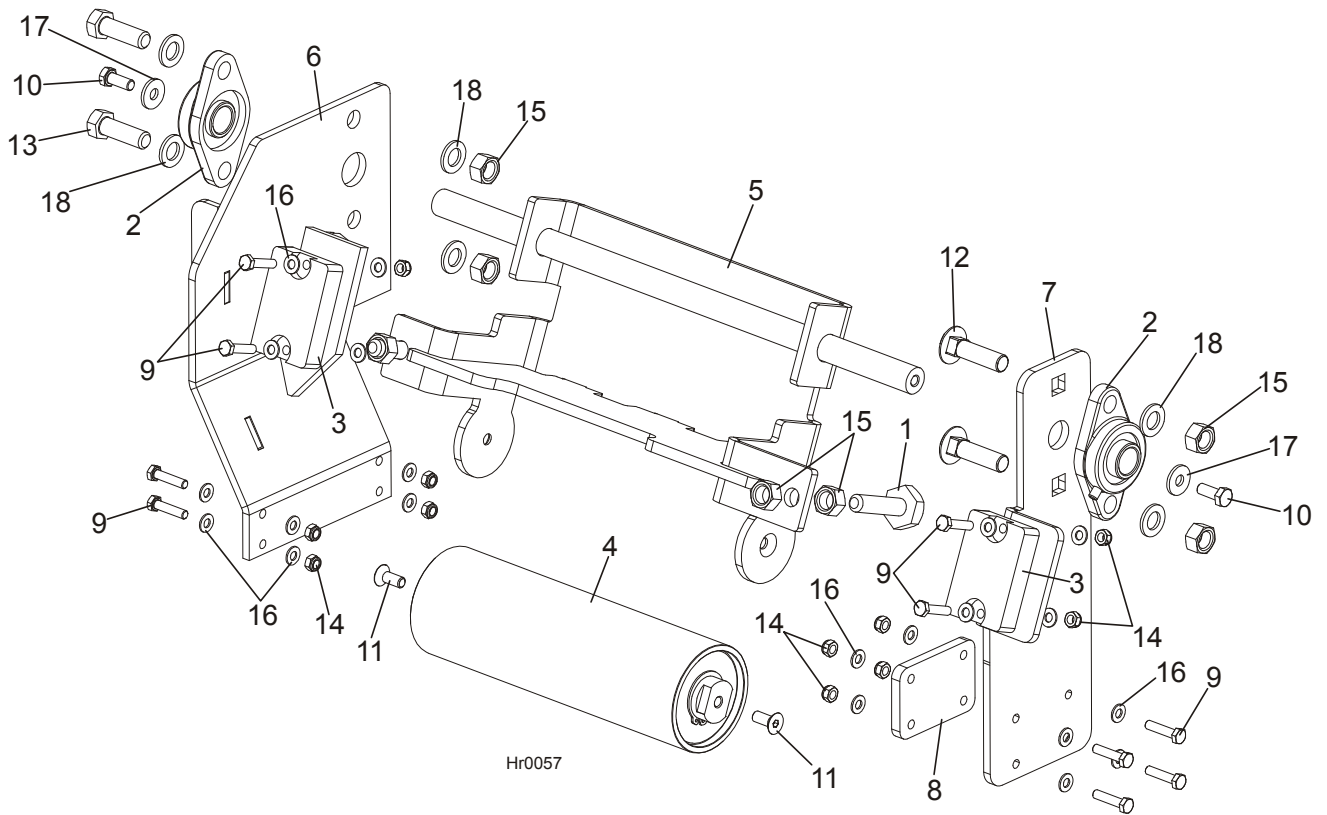

REF	DESCRIPTION (◆ Indicates Parts Available In Assemblies Only)	PART #	QTY.
	<b>ROLLER, HR110/115 HOLD-DOWN REAR</b>	504855	1
1	BOLT, BAD RAIL ADJUSTMENT	505006	2
2	BEARING, UCFL 205	089124	2
3	BUMPER, GRENE 70 3201 0010. SHR RUBBER	094969	2
4	ROLLER, HR110/115 HOLD-DOWN	504130	1
5	BRACKET, HR110/115 ROLLER REAR	504132-1	1
6	BRACKET, HOLD-DOWN ROLLER RIGHT	504521-1	1
7	BRACKET, HOLD-DOWN ROLLER LEFT	504548	1
8	PLATE, HR ROLLER REAR RETAINING	504864-1	1
9	BOLT, M8x35-8.8 HEX HEAD FULL THREAD ZINC	F81002-13	12
10	BOLT, M10X25-8.8-FE/ZN5	F81003-11	2
11	BOLT, M10x25 -10.9- Fe/Zn5 DIN 7991	F81003-82	2
12	BOLT, M16x60-8.8 TRUSS HEAD ZINC	F81006-32	2
13	BOLT, M16 X 50-8.8 HEX HEAD	F81006-7	2
14	NUT, M8-8-B HEX NYLON ZINC LOCK	F81032-2	12
15	NUT, M16-5.8 HEX ZINC	F81036-1	8
16	WASHER, 8.4 FLAT ZINC	F81054-1	24
17	WASHER, 10.5 ZINC FLAT SPECIAL	F81055-6	2
18	WASHER, 17 FLAT ZINC	F81058-1	6

# 4

## SAW HEAD & FEED TRACK

*Infeed, Outfeed & Return Tables*

### 4.8 Infeed, Outfeed & Return Tables

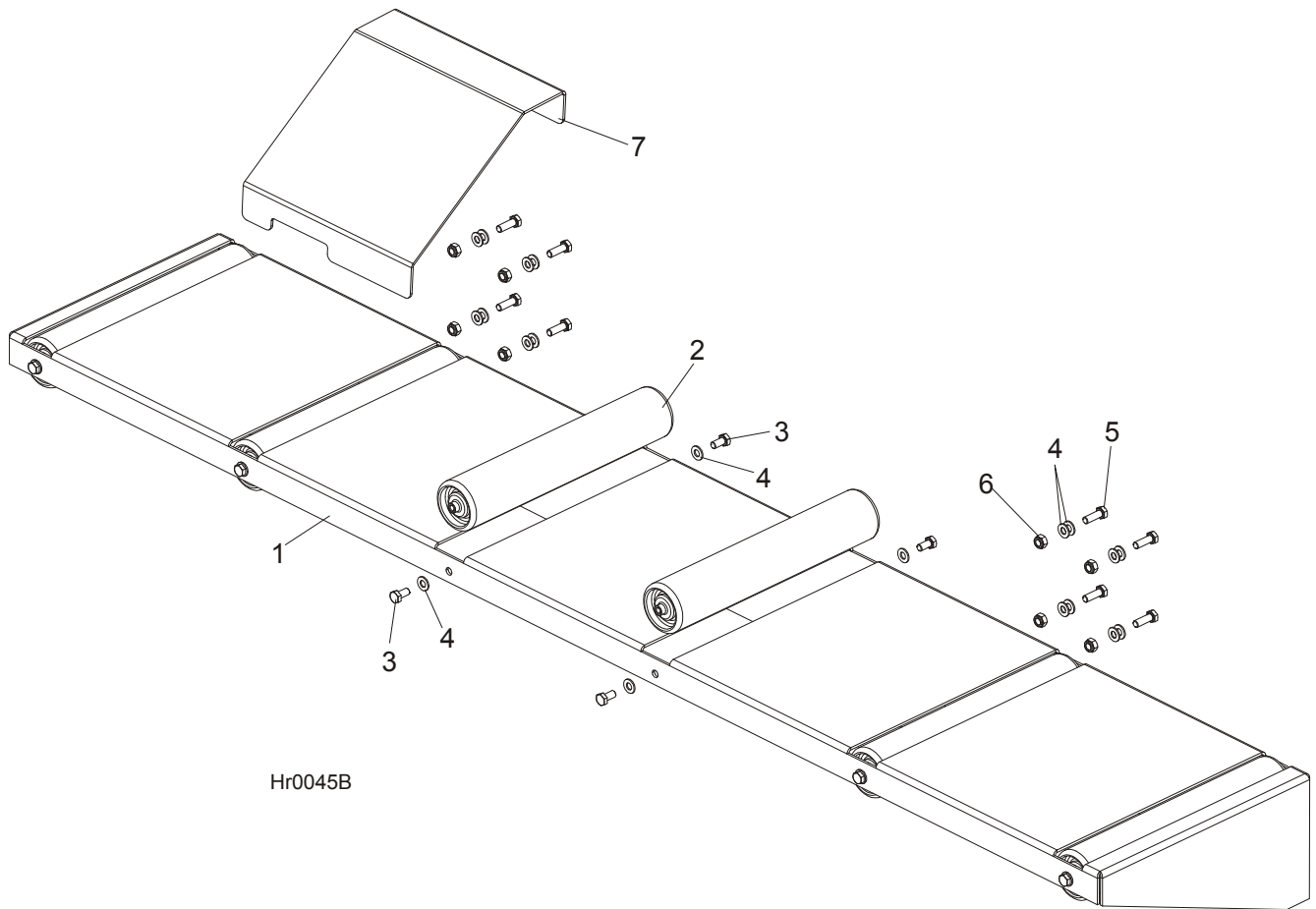

Hr0045B

REF	DESCRIPTION (◆ Indicates Parts Available In Assemblies Only)	PART #	QTY.	
	<b>TABLE, HR130 LONG COMPLETE</b>	503966	1	
1	TABLE, HR130 LONG	503991-1	1	
2	ROLLER, 76x400 W/M10 INTERNAL THREAD	093787	6	
3	BOLT, M10x20MM,HEX HEAD,GR 5.8 ZINC	F81003-1	12	
4	WASHER, 10.5 FLAT ZINC	F81055-1	28	
5	BOLT, M10x30-5.8 HEX HEAD FULL THREAD ZINC	F81003-2	8	
6	NUT, M10-8-B HEX NYLON ZINC LOCK	F81033-1	8	
7	<b>PLATE, BOARD RETURN</b>	504124-1	1	

4.9 Feed Track Assembly

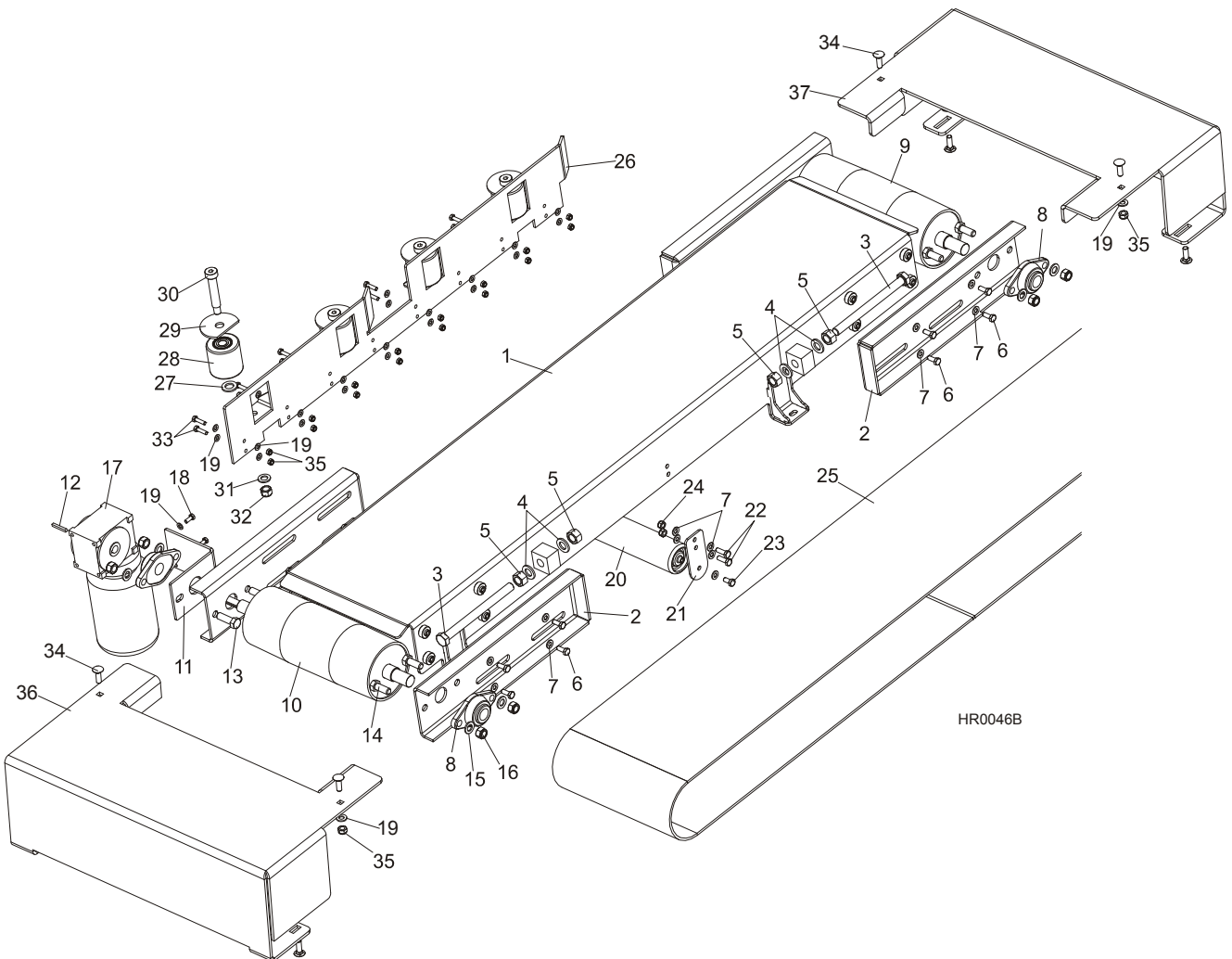

REF	DESCRIPTION (◆ Indicates Parts Available In Assemblies Only)	PART #	QTY.
	<b>TABLE, HR115 COMPLETE</b>	503780	1
1	TABLE, HR10/115	503775-1	1
2	BRACKET, HR300 PULLEY MOUNT PAINTED	504133-1	4
3	BOLT, M20X240-8.8 FE/ZN5 PN-85/M 82105	F81007-1	4
4	WASHER, 21 FLAT ZINC	F81059-2	8
5	NUT, M20-8 HEX ZINC	F81037-1	8
6	BOLT, M10X25-8.8-FE/ZN5	F81003-11	16
7	WASHER, 10.5 FLAT ZINC	F81055-1	26
8	BEARING, UCFL 206 CX BALL	090851	4
9	PULLEY, HR115 IDLE SIDE PAINTED	503776-1	1
10	PULLEY, HR115 DRIVE SIDE WITH VENEER	506519	1
11	BRACKET, GEAR BOX MOUNT PAINTED	504856-1	1
12	KEY, AB 6X6X45 PARALLEL	089229	1
13	BOLT, M16X50-8.8 HEX HEAD FULL THREAD ZINC	F81006-7	2

# 4 SAW HEAD & FEED TRACK

## Feed Track Assembly

14	BOLT, M16X40-8.8 HEX HEAD FULL THREAD ZINC	F81006-13	6	
15	WASHER, 17 FLAT ZINC	F81058-1	8	
16	NUT, M16-8 HEX NYLON ZINC LOCK	F81036-2	8	
17	MOTOREDUCER, RA-06/49/F3/N+S/V6	505079	1	
18	BOLT, M8X20-5.8 HEX HEAD FULL THREAD ZINC	F81002-1	2	
19	WASHER, 8.4 FLAT ZINC	F81054-1	4	
20	ROLLER, 76x400 W/M10 INTERNAL THREAD	093787	1	
21	SUPPORT, HR115 ROLLER	503782-1	2	
22	BOLT, M10x30-5.8 HEX HEAD FULL THREAD ZINC	F81003-2	4	
23	BOLT, M10X20MM, HEX HEAD, GR 5.8 ZINC	F81003-1	2	
24	NUT, M10-8-B HEX NYLON ZINC LOCK	F81033-1	4	
25	TYPE, EP 250/2 3+0 GRIP B=380 L=4900	503956	1	
	COVERING FOR PULLEYS	R00100	5 m	
	RIVET, P AL/FE 4X10 TUBULAR W/CORE	F81021-11	2	
	RUNNER, SIDE COMPLETE	503985	1	
26	RUNNER, HR130 SIDE	503984-1	1	
27	WASHER, 21 FLAT ZINC	F81059-2	4	
28	ROLLER, R-80-80 SIDE	099429	4	
29	COVER, SIDE ROLLER	503969-1	4	
30	BOLT, 20/M16X90 12.9 ISO7379 FITTED	F81006-30	4	
31	WASHER, 17 FLAT ZINC	F81058-1	4	
32	NUT, M16, HEX, NYLON ZINC LOCK	F81036-2	4	
33	BOLT, M8X30MM, HH, GR 5.8, FULL THRD, ZINC	F81002-2	16	
34	BOLT, M8 X 20 Fe/Zn5, PN-M/82406	F81002-11	8	
35	NUT, M8-8-B HEX NYLON ZINC LOCK	F81032-2	16	
36	COVER, HR110/115 TYPE LEFT	504122-1	1	
37	COVER, HR110/115 TYPE RIGHT	504134-1	1	

4.10 Table, Idle Roller

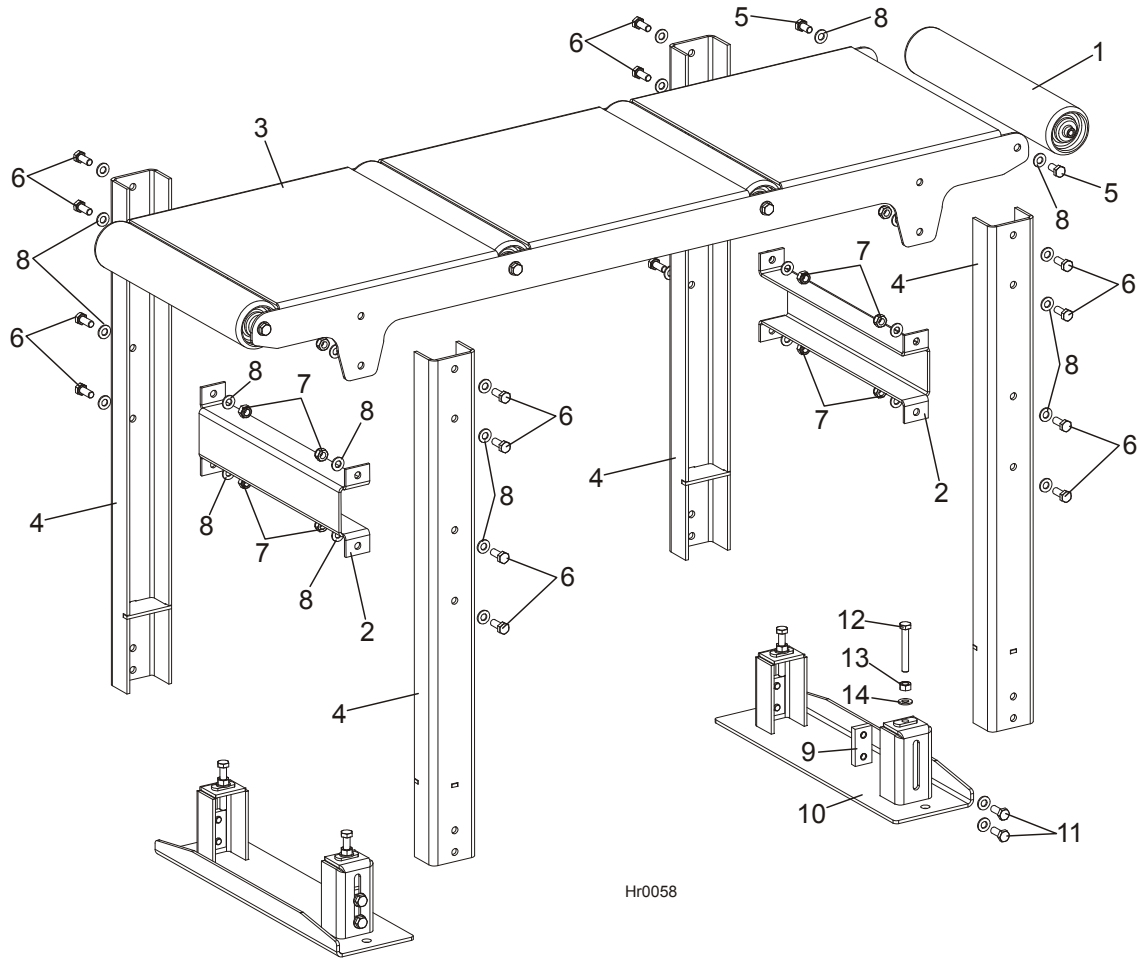

Hr0058

REF	DESCRIPTION (◆ Indicates Parts Available In Assemblies Only)	PART #	QTY.
	<b>TABLE, HR110/115 IDLE ROLLER COMPLETE</b>	504100	1
1	ROLLER, 76x400 W/M10 INTERNAL THREAD	093787	4
2	LINK, TABLE MIDDLE	504096-1	2
3	PLATE, TABLE MOUNTING	504101-1	1
4	SUPPORT, TABLE	504102-1	4
5	BOLT, M10X20MM HEX HEAD GR 5.8 ZINC	F81003-1	8
6	BOLT, M10 X 25 8.8 Fe/Zn5, PN-M/82105	F81003-31	16
7	NUT, M10-8-B HEX NYLON ZINC LOCK	F81033-1	16
8	WASHER, 10.5 FLAT ZINC	F81055-1	40
	<b>FOOT, COMPLETE</b>	504097	2
9	PLATE, M10 RETAINING	101242-1	2
10	FOOT, OUTRIGGER	504098-1	1
11	BOLT, M10X25-8.8-FE/ZN5	F81003-11	4
12	BOLT, M10 X 70-8.8 Fe/Zn5, PN-M/82105	F81003-20	2
13	NUT, M10-8-B-FE	F81033-3	2
14	WASHER, 10.5 FLAT ZINC	F81055-1	6

## SECTION 5 UP/DOWN SYSTEM

### 5.1 Up/Down Crank Assembly

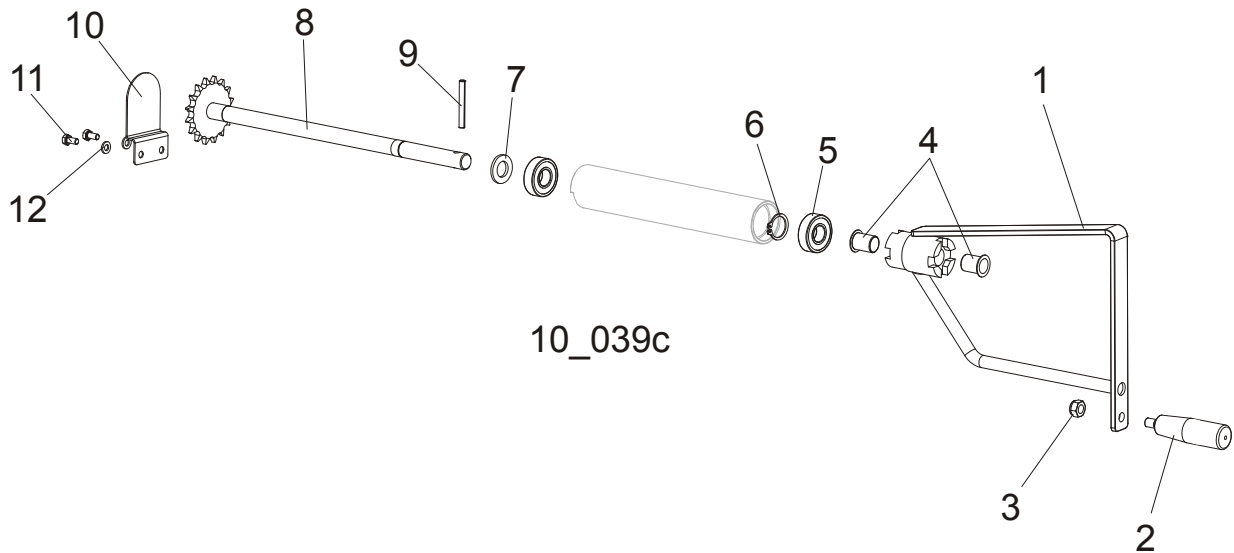

REF	DESCRIPTION (◆ Indicates Parts Available In Assemblies Only)	Part #	Qty.
	<b>FEED CRANK COMPLETE</b>	502967	1
1	CRANK, WELDMENT LT105	086120-1	1
2	KNOB, 12992M10 PLASTIC CRANK HANDLE	086338	1
3	NUT, M10-8-B HEX NYLON ZINC LOCK	F81033-1	1
4	BUSHING, GFM-1719-25	094142	2
5	BEARING, 6203-2RS	086114	2
6	RING, Z 17 OUTSIDE RETAINING	F81090-21	1
7	WASHER, 17 FLAT ZINC	F81058-1	1
8	SHAFT W/SPROCKET LT10	097242-1	1
9	PIN, 6X50 ZINC ROLL	F81045-1	1
10	GUARD, UPPER LT10 SAW HEAD SPROCKET	092567-1	1
11	BOLT, M6X12-8.8 HEX HEAD FULL THREAD ZINC	F81001-7	2
12	WASHER, 6.4 FLAT ZINC	F81053-1	2

## 5.2 Up/Down Drive Sprocket Assembly

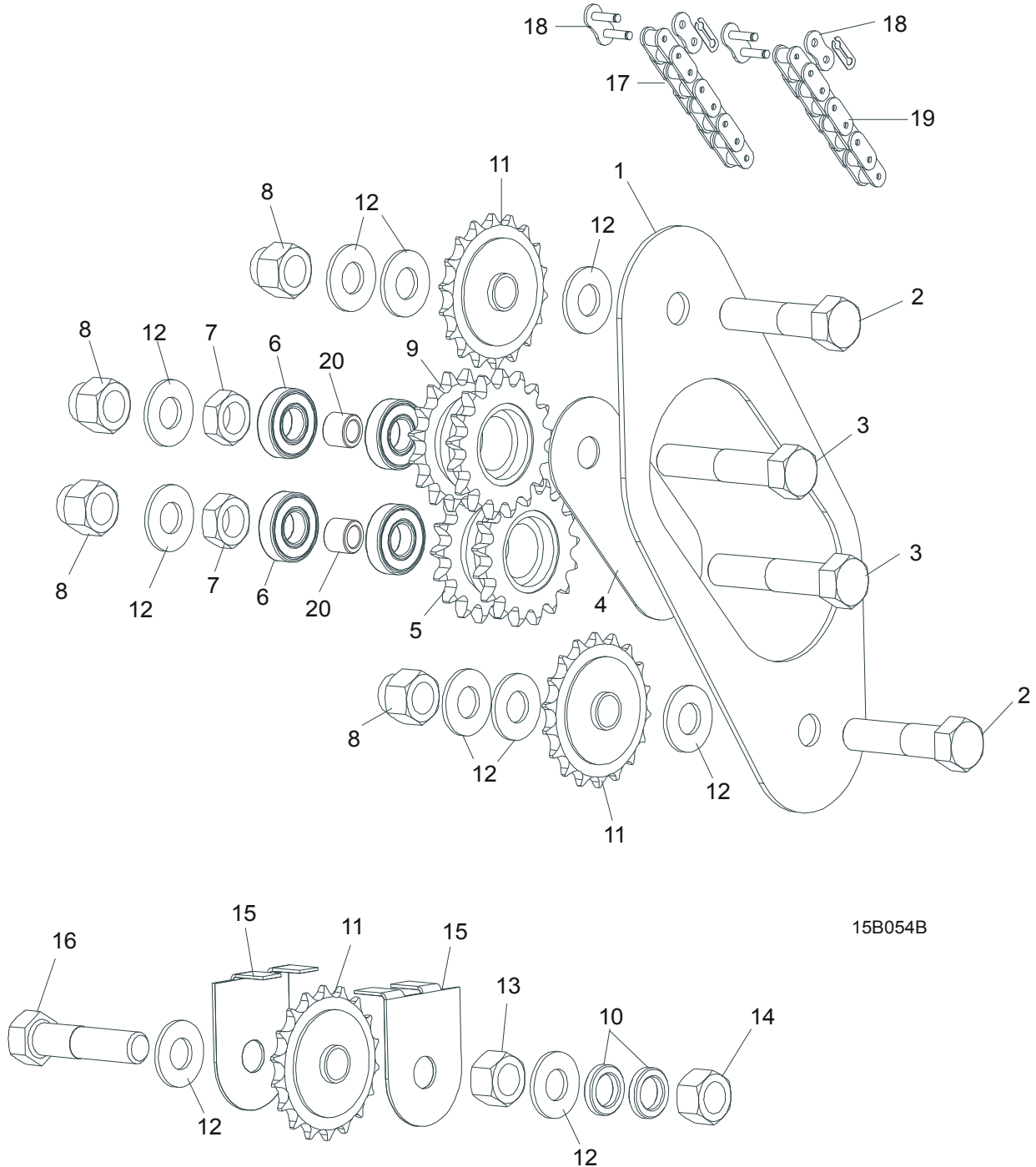

REF	DESCRIPTION (◆ Indicates Parts Available In Assemblies Only)	Part #	Qty.
1	GUARD, UP/DOWN CHAIN INTERNAL LT10	014907	1
2	BOLT, M16X65-8.8-B HEX HEAD FULL THREAD ZINC	F81006-1	2
3	BOLT, M16X80 8.8-B HEX HEAD FULL THREAD ZINC	F81006-11	2
4	PLATE, UP/DOWN DRIVE SPROCKET MOUNT PTD	087104-1	1

## 5

**UP/DOWN SYSTEM***Up/Down Drive Sprocket Assembly*

5	<b>SPROCKET DUAL 17/17 PTD</b>	086812-1	1	
6	<b>BEARING, R-10</b>	P04156	4	
7	<b>NUT, M16 HEX THIN ZINC</b>	F81036-4	2	
8	<b>NUT, M16-8 HEX NYLON ZINC LOCK</b>	F81036-2	4	
9	<b>SPROCKET DUAL 16/17 PTD</b>	086813-1	1	
10	<b>WASHER, 41/64"X 1"X 3/16 SPACER</b>	S12480	3	
11	<b>SPROCKET, 17T G1#40-41 5/8" ID</b>	P04333	3	
12	<b>WASHER 17 FLAT ZINC</b>	F81058-1	12	
13	<b>NUT M16-5.8 HEX ZINC</b>	F81036-1	1	
14	<b>NUT, M16-8 HEX NYLON ZINC LOCK</b>	F81036-2	1	
15	<b>GUARD,LT10 UP/DOWN CHAIN SPROCKET</b>	092566-1	2	
16	<b>BOLT, M16X75-8.8-B HEX HEAD FULL THREAD ZINC</b>	F81006-10	1	
17	<b>CHAIN, #40 X 111 1/2"</b>	014831	1	
18	<b>LINK, #40 MASTER</b>	P04200	2	
19	<b>CHAIN, #40 X 15 1/2"</b>	P12496	1	
20	<b>BUSHING - ZINC</b>	095938-1	2	



### 5.3 Slide Pads And Blade Height Scale

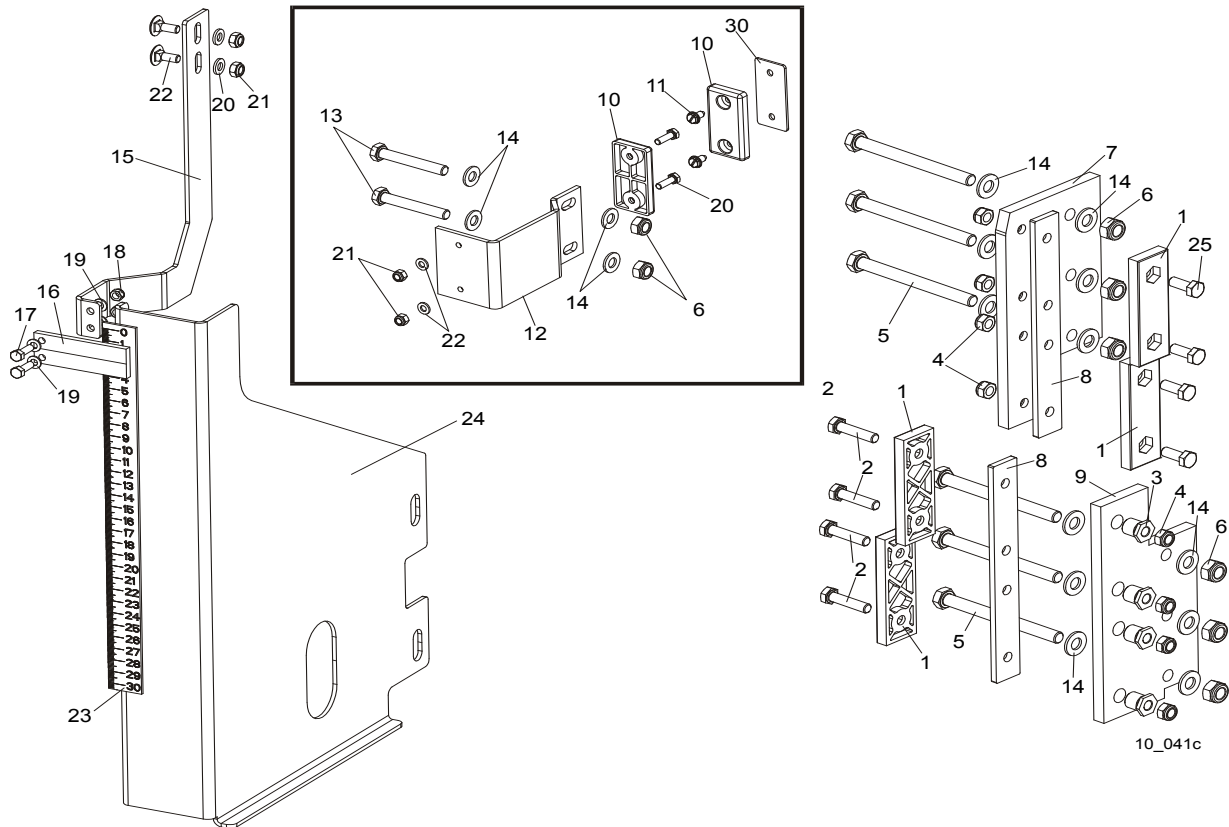

REF	DESCRIPTION (◆ Indicates Parts Available In Assemblies Only)	Part #	Qty.
1	PADS, UP/DOWN SLIDE	M04096	4
2	BOLT, M8X35 -8.8 HEX HEAD FULL THREAD ZINC	F81002-13	4
3	NUT, LT10 SLIDE PAD ADJUSTMENT ZINC-PLATED	086683-1	4
4	NUT, M8-8-B HEX NYLON ZINC LOCK	F81032-2	8
5	BOLT, M10X110 8.8 HEX HEAD ZINC	F81003-43	6
6	NUT, M10-8-B HEX NYLON ZINC LOCK	F81033-1	8
7	PLATE, LT10 SLIDE PAD MOUNT	094139-1	1
8	BACKING, MAST SLIDE PADS	094140-1	2
9	PLATE, SLIDE PAD MOUNT	086682-1	1
10	PAD, CATERPILLAR TRACK	P13576	2
11	BOLT, 1/4-20 X 1/2" SELF TAP HEX HEAD	F05015-1	2
12	BRACKET, LT10MAST GUIDE IDLE SIDE PAINTED	087192-1	1
13	BOLT, M10X70-8.8 HEX HEAD FULL THREAD ZINC	F81003-20	2
14	WASHER, 10.5 FLAT ZINC	F81055-1	16
	INDICATOR, BLADE HEIGHT COMPLETE HR110	<b>504541</b>	<b>1</b>
15	BRACKET, LT10 BLADE HEIGHT SCALE MOUNT	504542-1	1
16	Indicator, Blade Height Scale	094821	1

## 5

**UP/DOWN SYSTEM***Slide Pads And Blade Height Scale*

17	Bolt, M5x16 -8.8 Hex Head Full Thread Zinc	F81000-20	2	
18	NUT, M5-8-Fe/Zn5 DIN985	F81030-2	2	
19	WASHER, 5.3 FLAT ZINC	F81052-1	4	
20	WASHER, 6.4 FLAT ZINC	F81053-1	2	
21	NUT, M6-8-B HEX NYLON ZINC LOCK	F81031-2	2	
22	BOLT M6x16 -8.8- Fe/Zn5 PN/M-82406	F81001-36	2	
23	<b>BLADE HEIGHT SCALE HR115</b>	504127	1	
24	<b>BRACKET WLDMT, HEIGHT SCALE MOUNTING PTD</b>	504540-1	1	
25	<b>BOLT, M8X20MM, HEX HEAD,GR 5.8 ZINC</b>	F81002-4	4	