



user manual

Instrukcja obsługi | Руководство по использованию
Manuel de l'Utilisateur | Betriebsanleitung
Bruksanvisning | Manual del Usuario
Betjeningsvejledning | Gebruikershandleiding
Käyttöohjeet | Manual de utilizare | Bruksanvisning
Manuale d'uso | Příručka uživatele | Navodila za uporabo

Retain for future use
Zachować do przyszłego użytku
Сохраните для последующего
использования
A conserver pour une utilisation future
Für zukünftige Benutzung aufbewahren
Behold for senere bruk
Säilytä nämä käyttöohjeet tulevaa tarvetta marten
Opbevar manualen til fremtidig brug
Bewaren voor gebruik in de toekomst
Conservare il presente manuale a l'uso futuro
Păstrați acest manual pentru utilizare viitoare
Conservar para futuras consultas
Behall för framtida användning
Uchovajte pro další použití
Hranite za prihodnjo uporabo

Horizontal Resaw HR115

Safety, Setup, Operation & Maintenance Manual

HR115

rev.A1.00



Safety is our #1 concern! Read and understand all safety information and instructions before operating, setting up or maintaining this machine.

September 2010

Form #924

**This is the original language
for the manual**

If You Need To Order Parts...

From Europe call our European Headquarters and Manufacturing Facility in Kolo-Poland, Nagorna 114 St., at **+48-63-2626000** or **+48-3912-1319**. From the continental U.S., call our toll-free Parts hotline at **1-800-448-7881**. Please have the vehicle identification number and your customer number ready when you call. Wood-Mizer will accept these methods of payment:

- Visa, Mastercard, or Select Purchase
- COD
- Prepayment
- Net 15 (with approved credit)

Be aware that shipping and handling charges may apply. Handling charges are based on size and quantity of order. In most cases, items will ship on the day they are ordered. Second Day and Next Day shipping are available at additional cost.

If You Need Service...

From Europe call our European Headquarters and Manufacturing Facility in Kolo-Poland, Nagorna 114 St. at **+48-63-2626000** or **+48-3912-1319**. From the continental U.S., call us toll-free at **1-800-525-8100**. Ask to speak with a Customer Service Representative. Please have your vehicle identification number and your customer number ready when you call. The Service Representative can help you with questions about alignment of your mill, blade sharpening, or cutting a particular species of wood. He also can schedule you for a service call.

Office Hours: All times are Eastern Standard Time. Please remember that Indiana does not go on Daylight Savings Time in the summer.

Country	Monday - Friday	Saturday	Sunday
U.S., Indiana	8 a.m. to 5 p.m.	8 a.m. to 4 p.m.	Closed
Poland	8 a.m. to 4:30 p.m.	8 a.m. to 1 p.m.	Closed



IMPORTANT! Read the entire Operator's Manual before operating the sawmill. Take notice of all safety warnings throughout this manual and those posted on the machine. Keep this manual with this machine at all times, regardless of ownership.

Manufactured by:

Wood-Mizer®

114 Nagorna Street, 62-600 Kolo, Poland

Table of Contents

Section-Page

SECTION 1	SAFETY	1-1
1.1	Safety Symbols.....	1-1
1.2	Safety Instructions.....	1-2
SECTION 2	OPERATION	2-1
2.1	Control Overview	2-1
2.2	Resaw Setup	2-3
2.3	Replacing The Blade	2-5
2.4	Tensioning The Blade.....	2-6
2.5	Tracking The Blade	2-7
2.6	Tilt Adjustment.....	2-9
2.7	Machine Start.....	2-10
2.8	Water Lube Operation	2-13
2.9	Operation Procedure	2-14
SECTION 3	MAINTENANCE	3-1
3.1	Wear Life.....	3-1
3.2	Sawdust Removal	3-1
3.3	Vertical Mast Rails	3-1
3.4	Miscellaneous Lubrication	3-2
3.5	Blade Wheel Belts	3-2
3.6	Up/Down System.....	3-3
3.7	Miscellaneous Maintenance	3-5
3.8	Drive Belt Adjustment.....	3-6
3.9	Safety Devices Inspection	3-7
SECTION 4	ALIGNMENT	4-1
4.1	Pre-Alignment Procedures.....	4-1
4.2	Preparing The Sawmill For Alignment	4-1
4.3	Blade Installation and Alignment.....	4-1
4.4	Blade Wheel Alignment	4-2
4.5	Blade Guide Arm Alignment.....	4-6
4.6	Aligning The Blade Guides	4-8
4.7	Blade Deflection.....	4-9
4.8	Blade Guide Vertical Tilt Adjustment.....	4-9
4.9	Blade Guide Spacing	4-11
4.10	Horizontal Tilt Adjustment.....	4-12
4.11	Blade Height Scale Adjustment.....	4-13
4.12	Motor Drive Belt Adjustment.....	4-14
SECTION 5	SPECIFICATIONS	5-1
5.1	Overall Dimensions	5-1

Table of Contents

Section-Page

5.2	Cutting Capacity	5-3
5.3	Belt Sizes	5-4
5.4	Blade Motor Specifications	5-4
5.5	Electrical Diagram, CE version	5-5
5.6	Electrical Component List, HR115	5-7

SECTION 1 SAFETY

1.1 Safety Symbols

The following symbols and signal words call your attention to instructions concerning your personal safety. Be sure to observe and follow these instructions.



DANGER! indicates an imminently hazardous situation which, if not avoided, will result in death or serious injury.



WARNING! suggests a potentially hazardous situation which, if not avoided, could result in death or serious injury.



CAUTION! refers to potentially hazardous situations which, if not avoided, may result in minor or moderate injury or damage to equipment.



IMPORTANT! indicates vital information.

NOTE: gives helpful information.



Warning stripes are placed on areas where a single decal would be insufficient. To avoid serious injury, keep out of the path of any equipment marked with warning stripes.

1.2 Safety Instructions



IMPORTANT! The sawmill is intended for sawing wood only. [See Section 5.2](#) for log size capacities of the machine.

IMPORTANT! The operator of the sawmill should get adequate training in the operation and adjustment of the machine.

NOTE: ONLY safety instructions regarding personal injury are listed in this section. Caution statements regarding only equipment damage appear where applicable throughout the manual.

Observe Safety Instructions



IMPORTANT! Read the entire Operator's Manual before operating the resaw. Take notice of all safety warnings throughout this manual and those posted on the machine. Keep this manual with this machine at all times, regardless of ownership.

Also read any additional manufacturer's manuals and observe any applicable safety instructions including dangers, warnings, and cautions.

Only persons who have read and understood the entire operator's manual should operate the resaw. The resaw is not intended for use by or around children.

IMPORTANT! It is always the owner's responsibility to comply with all applicable federal, state and local laws, rules and regulations regarding the ownership and operation of your Wood-Mizer resaw. All Wood-Mizer resaw owners are encouraged to become thoroughly familiar with these applicable laws and comply with them fully while using the machine.



Wear Safety Clothing



WARNING! Secure all loose clothing and jewelry before operating the resaw. Failure to do so may result in serious injury or death.

WARNING! Always wear gloves and eye protection when handling bandsaw blades. Changing blades is safest when done by one person! Keep all other persons away from area when coiling, carrying or changing a blade. Failure to do so may result in serious injury.

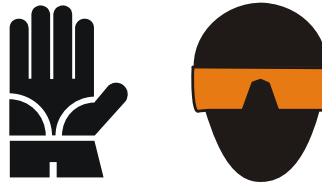

WARNING! Always wear eye, ear, respiration, and foot protection when operating or servicing the resaw.



Keep Resaw And Area Around Resaw Clean



DANGER! Maintain a clean and clear path for all necessary movement around the resaw and lumber stacking areas. Failure to do so will result in serious injury.

Dispose Of Sawing By-Products Properly



IMPORTANT! Always properly dispose of all sawing by-products, including sawdust and other debris.

1 Safety

Check Resaw Before Operation

Check Resaw Before Operation

 **DANGER!** Make sure all guards and covers are in place and secured before operating the resaw. Failure to do so may result in serious injury.



Keep Persons Away

 **DANGER!** Keep all persons out of the path of moving equipment and lumber when operating the resaw. Failure to do so will result in serious injury.

DANGER! Always be sure all persons are out of the path of the blade before starting the motor. Failure to do so will result in serious injury.

 **WARNING!** Allow blade to come to a complete stop before opening the blade housing cover. Failure to do so will result in serious injury.

Keep Hands Away



DANGER! Always shut off the blade motor before changing the blade. Failure to do so will result in serious injury.

DANGER! Motor components can become very hot during operation. Avoid contact with any part of a hot motor. Contact with hot motor components can cause serious burns. Therefore, never touch or perform service functions on a hot motor. Allow the motor to cool sufficiently before beginning any service function.

DANGER! Always keep hands away from moving bandsaw blade. Failure to do so will result in serious injury.

DANGER! Always be aware of and take proper protective measures against rotating shafts, pulleys, fans, etc. Always stay a safe distance from rotating members and make sure that loose clothing or long hair does not engage rotating members resulting in possible injury.



WARNING! Use extreme caution when spinning the blade wheels by hand. Make sure hands are clear of blade and wheel spokes before spinning. Failure to do so may result in serious injury.

Use Proper Maintenance Procedures



DANGER! Make sure all electrical installation, service and/or maintenance work is performed by a qualified electrician and is in accordance with applicable electrical codes.

DANGER! Hazardous voltage inside the electric boxes and at the motor can cause shock, burns, or death. Disconnect and lock out power supply before servicing! Keep all electrical component covers closed and securely fastened during resaw operation.



WARNING! Consider all electrical circuits energized and dangerous.

WARNING! Disconnect and lock out power supply before servicing the resaw! Failure to do so may result in serious injury.

WARNING! Never assume or take the word of another person that the power is off; check it out and lock it out.

WARNING! Do not wear rings, watches, or other jewelry while working around an open electrical circuit.

WARNING! Remove the blade before performing any service to the motor or resaw. Failure to do so may result in serious injury.



DANGER! Never clean the blade or blade wheels using the hand-held brush or scraper whilst the saw blade is in motion.

CAUTION! Before installation of the blade, inspect it for damage and cracks. Use only properly sharpened blades. Always handle the blade with extreme caution. Use suitable carrier equipment for transporting the blades.

CAUTION! Always wear gloves when handling the blade. Never grab the blade with bare hands!

CAUTION! If the blade breaks during sawmill operation, push the EMERGENCY STOP button to stop the blade motor and wait 10 seconds before you open the blade housing cover.

CAUTION! The sawmill's work-stand should be equipped with a 4 kg or bigger dry powder extinguisher.

Keep Safety Labels In Good Condition



IMPORTANT! Always be sure that all safety decals are clean and readable. Replace all damaged safety decals to prevent personal injury or damage to the equipment. Contact your local distributor, or call your Customer Service Representative to order more decals.

IMPORTANT! If replacing a component which has a safety decal affixed to it, make sure the new component also has the safety decal affixed.

See Table 1-1. Pictogram decals used to warn and inform the user about danger in the resaw.

TABLE 1-1

Decal View	W-M No.	Description
	096317	CAUTION! Read thoroughly the manual before operating the machine. Observe all safety instructions and rules when operating the sawmill.

1 **Safety**
Keep Safety Labels In Good Condition

TABLE 1-1

	<p>099220</p>	<p>CAUTION! Close all guards and covers before starting the machine.</p>
	<p>099219</p>	<p>Blade tension. Turning the bolt clockwise will increase the blade tension and turning the bolt counterclockwise will decrease the tension.</p>
	<p>099221</p>	<p>CAUTION! Keep all persons a safe distance away from work area when operating the machine.</p>

TABLE 1-1

	<p>099540</p>	<p>CAUTION! Gear danger – keep a safe distance away!</p>
	<p>096316</p>	<p>Do not open or close the electric box when the switch is not in the "0" position.</p>
	<p>096319</p>	<p>Disconnect power supply before opening the box.</p>
	<p>099222</p>	<p>CAUTION! Sawdust outlet. Protect eyes!</p>

1 **Safety**
Keep Safety Labels In Good Condition

TABLE 1-1







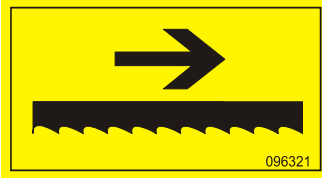

	<p>096321</p>	<p>Blade movement direction</p>
	<p>S12004G</p>	<p>CAUTION! Always wear safety goggles when operating the sawmill!</p>
	<p>S12005G</p>	<p>CAUTION! Always wear protective ear muffs when operating the sawmill!</p>
	<p>501465</p>	<p>CAUTION! Always wear safety boots when operating the sawmill</p>
	<p>501467</p>	<p>Lubrication Point</p>

TABLE 1-1

 <p style="text-align: right; font-size: small;">P11789b</p>	<p>P11789</p>	<p>Aligning the blade on the wheels</p>
 <p style="text-align: right; font-size: small;">092597</p>	<p>092597</p>	<p>Setting the blade tension indicator</p>
	<p>P85070</p>	<p>CE safety certification</p>
 <p style="text-align: right; font-size: small;">099401</p>	<p>099401</p>	<p>Russian safety certification</p>
 <p style="text-align: right; font-size: small;">S20097</p>	<p>S20097</p>	<p>Motor rotation direction</p>

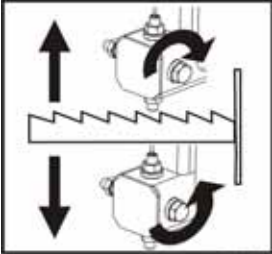
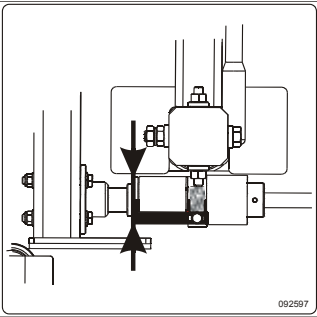
SECTION 2 OPERATION

2.1 Control Overview

1. Control Panel

See **Figure 2-1**. The control panel includes switches to start and stop the feed track and the saw head.

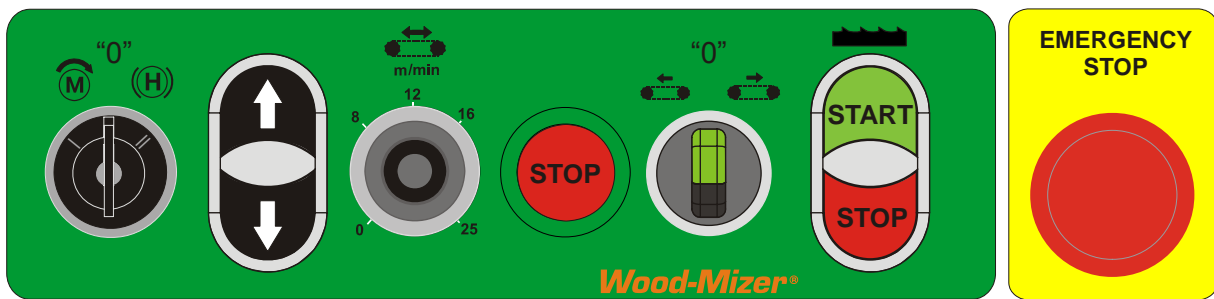

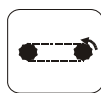

FIG. 2-1 CONTROL PANEL COMPONENTS

2. Blade Drive

 To start the blade motor, turn the key switch to the  position. Then place the START/STOP switch in the START position (press on START) and release the switch. To stop the blade motor, place the START/STOP switch in the STOP position and then release the switch.

3. Feed Track



 To start the feed track, place the START/STOP switch in the START position (press on START) and then release the switch. To stop the feed track, place the START/STOP switch in the STOP position and release.

4. Feed Track Speed Adjustment

 The feed track speed switch controls the speed at which the feed track moves. Turn the switch clockwise to increase the speed, counterclockwise to reduce the speed.

5. Key Switch

The key switch has three positions:

- “0” position - all electrical circuits are off,
-  position - all electrical circuits are on,
-  position - releases the motor disk brake, the blade and the track feed motors are off.

6. Saw Head Up/Down

To raise the saw head press up button. To lower the saw head press down button.

7. Emergency Stop

Push the emergency stop button to stop the blade and the track feed motors. Turn the emergency stop clockwise to release the stop. The resaw will not restart until the emergency stop is released.

2.2 Resaw Setup



IMPORTANT! Before starting to use the sawmill you have to meet the following conditions:

- Set up the sawmill on firm, level ground and level the sawmill. Secure the sawmill to the ground to prevent moving during operation. A concrete foundation or pads (rated to support 31 T/m² at each sawmill foot position) and 16mm anchored bolts are recommended.
- Under roof, the sawmill should always be operated with the sawdust collection system.
- The sawmill can be operated under roof only.
- The sawmill can be operated in temperature range from -15° C to 40° C only.
- The illumination at the operator's position should be at least 300lx.
- The sawmill operator's position is shown below.

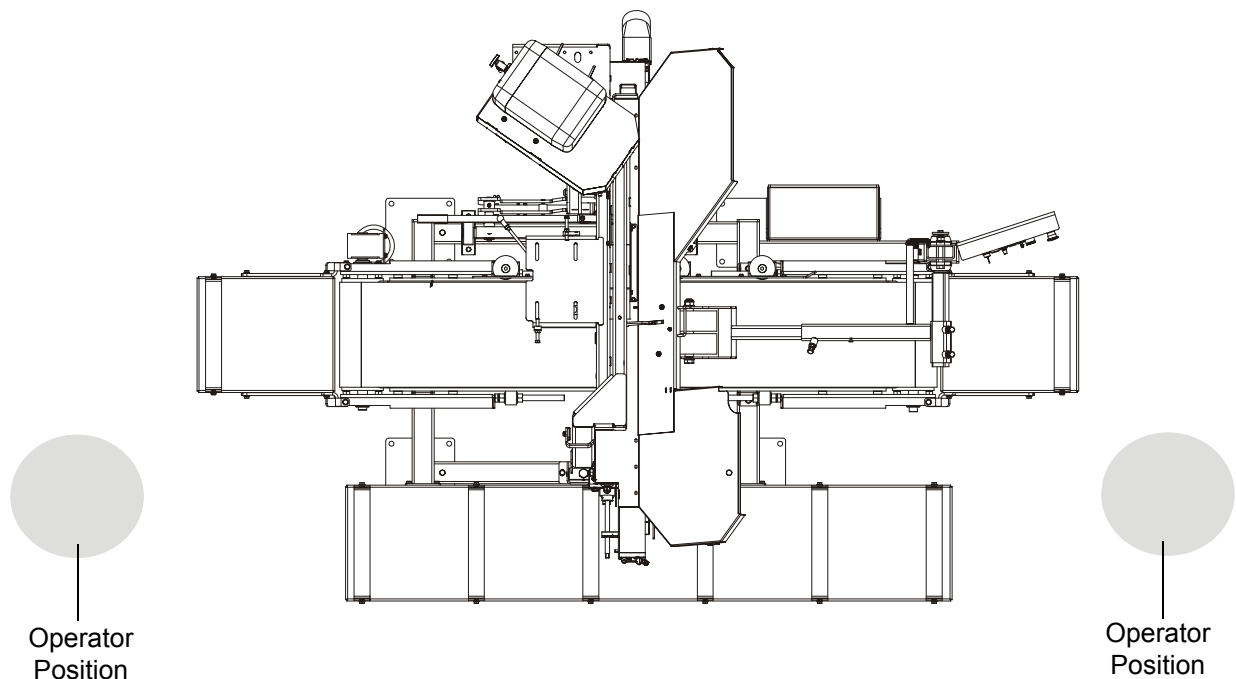

- Have a qualified electrician install the power supply (according to EN 60204 Standard). The power supply must meet the specifications given in the table below.

3-Phase Volts	Fuse Disconnect	Suggested Wire Size
400 VAC	16 A	2,5 mm ² to 15m length

TABLE 2-0



IMPORTANT! When starting the machine for the first time, check that main motor rotation direction is as indicated by the arrow located on the motor body (fan guard). If the rotation direction is incorrect, invert the phases in the phase inverter located in the power socket (electric box). Setting the phases in the phase inverter correctly will ensure correct rotation directions of all sawmill motors.

- The resaw can be lifted using a forklift only. The forklift must be rated for at least 2000kg. The resaw is equipped with forklift pockets. Insert the forks into the pockets shown on the picture below.

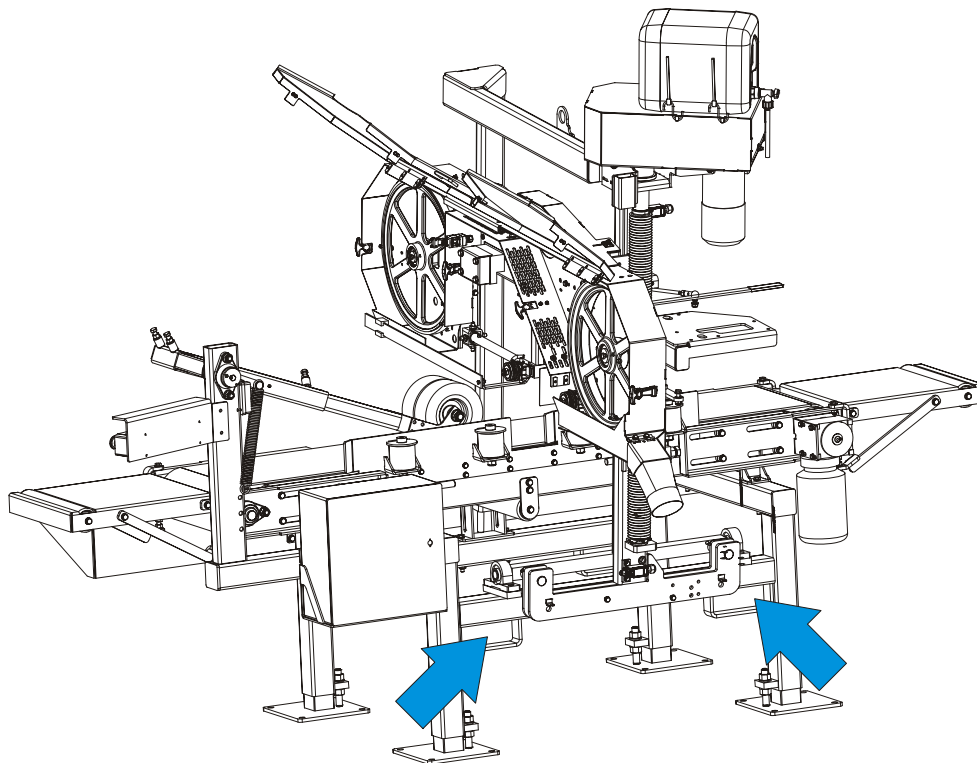

FIG. 2-2

2.3 Replacing The Blade



DANGER! Always shut off the resaw motor before changing the blade. Failure to do so may result in serious injury.



WARNING! Always wear gloves and eye protection whenever handling bandsaw blades. Changing blades is safest when done by one person! Keep all other persons away from work area when changing blades. Failure to do so may result in serious injury.

Raise the blade housing cover. Turn the blade tension handle to release the blade tension until the wheel is pulled in and the blade is lying loose in the blade housing. Lift the blade out of the blade housing.

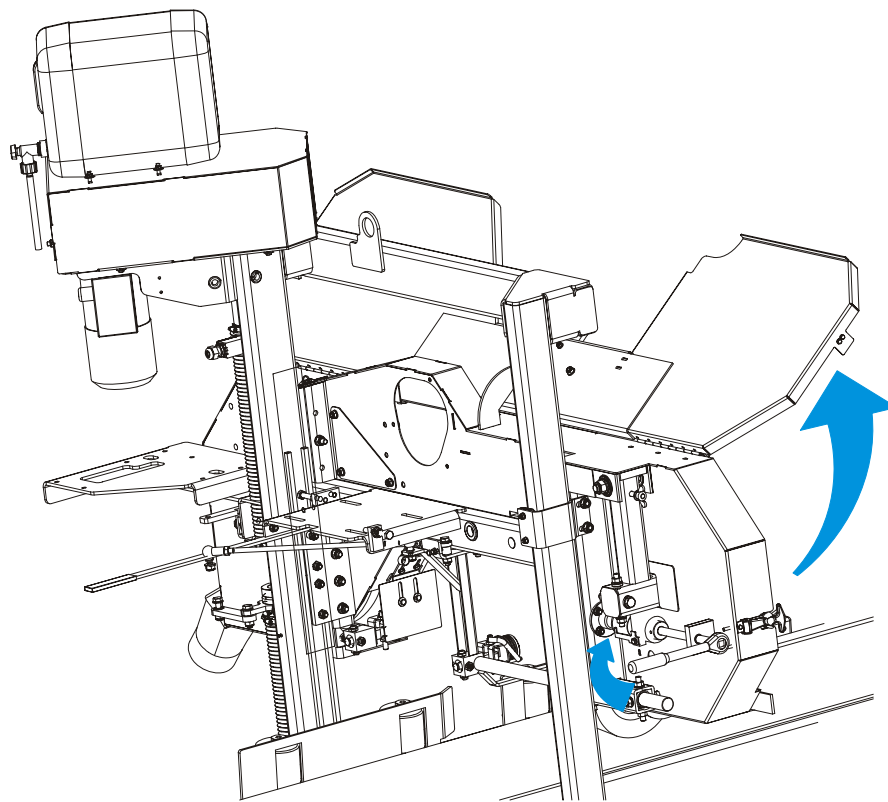

Install a new blade around the two blade wheels so that the teeth located between the blade guide assemblies point to the drive side of the machine. Make sure the teeth are pointing the correct direction.

Position 1 1/4" wide blades on the wheels so the gullet is 3.0 mm (\pm 1.0 mm) out from the front edge of the wheel.

Close the blade housing cover.

Next, tension the blade as described in the following instructions.

2.4 Tensioning The Blade

See Figure 2-3. Place the provided ratchet on the blade tensioner shaft. Turn the ratchet clockwise until the outside face of the rubber spring washer is even with the indicator (see the figure below). Check the blade tension occasionally when adjusting the cant control or while cutting and adjust if necessary. As the blade and belts heat up and stretch, the blade tension will change. Also, ambient temperature changes can cause tension to change.

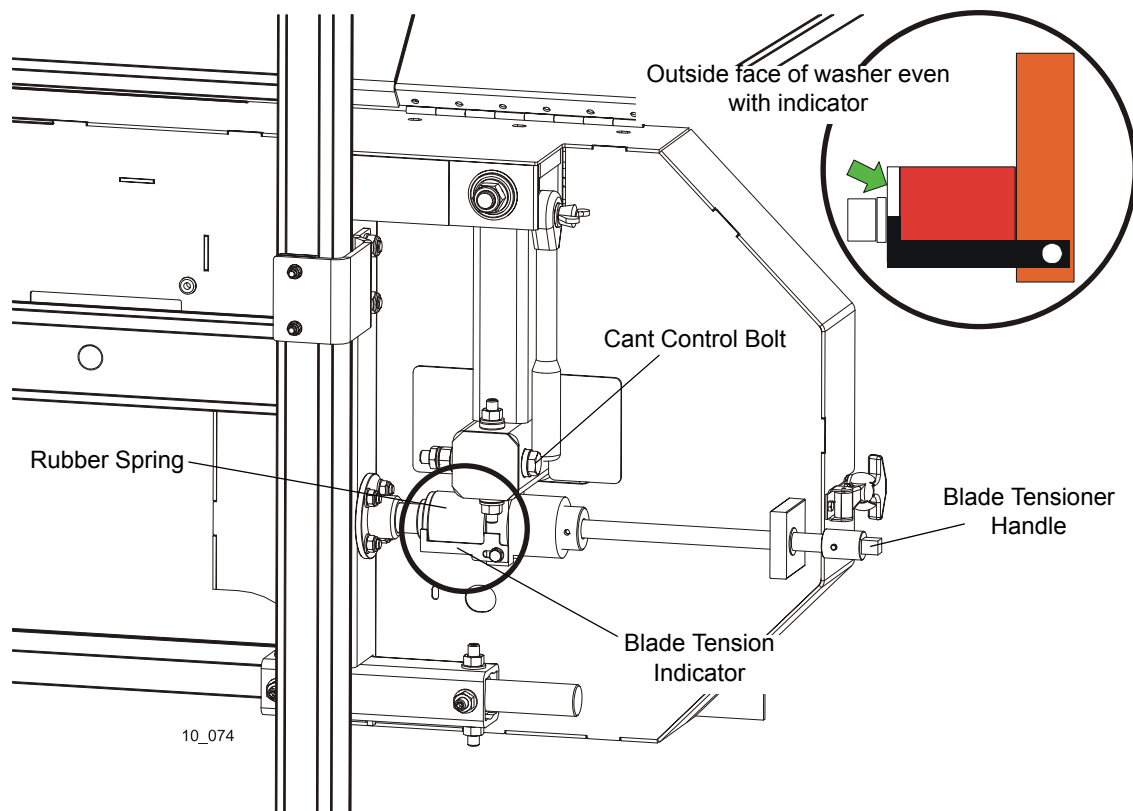

FIG. 2-3



CAUTION! Release the blade tension when the resaw is not in use.

2.5 Tracking The Blade

1. Open the blade housing cover.
2. Turn the key switch to the "H" position.



3. Manually spin one of the blade wheels until the blade positions itself on the blade wheels.
4. Check that the blade is properly positioned on the blade wheels.

See **Figure 2-4**. 1 1/4" wide blades should be placed on the blade wheels so that the

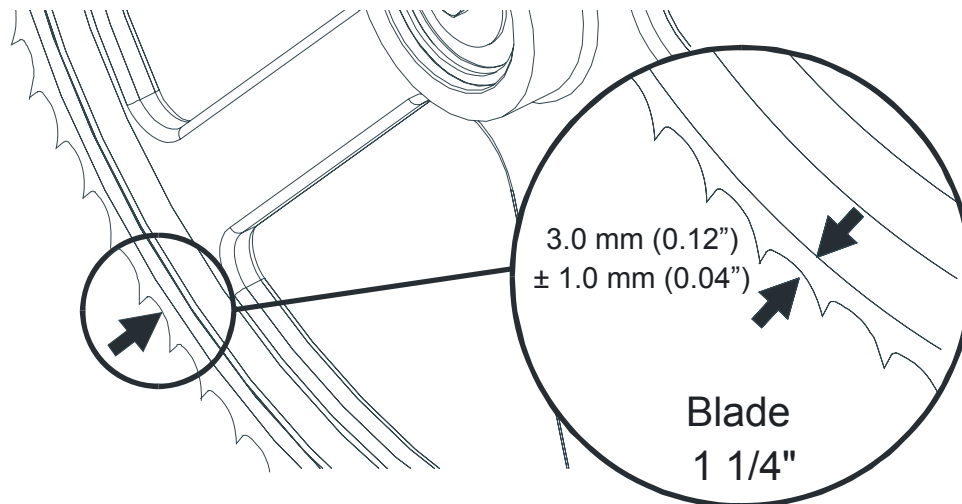

FIG. 2-4

gullet is 3.0 mm (0.12") ± 1.0 mm (0.04") out from the front edge of the wheel.

5. Use the cant adjustment bolt to adjust where the blade travels on the blade wheels.

See **Figure 2-5**. To adjust where the blade travels on the blade wheels, use the cant control bolt.

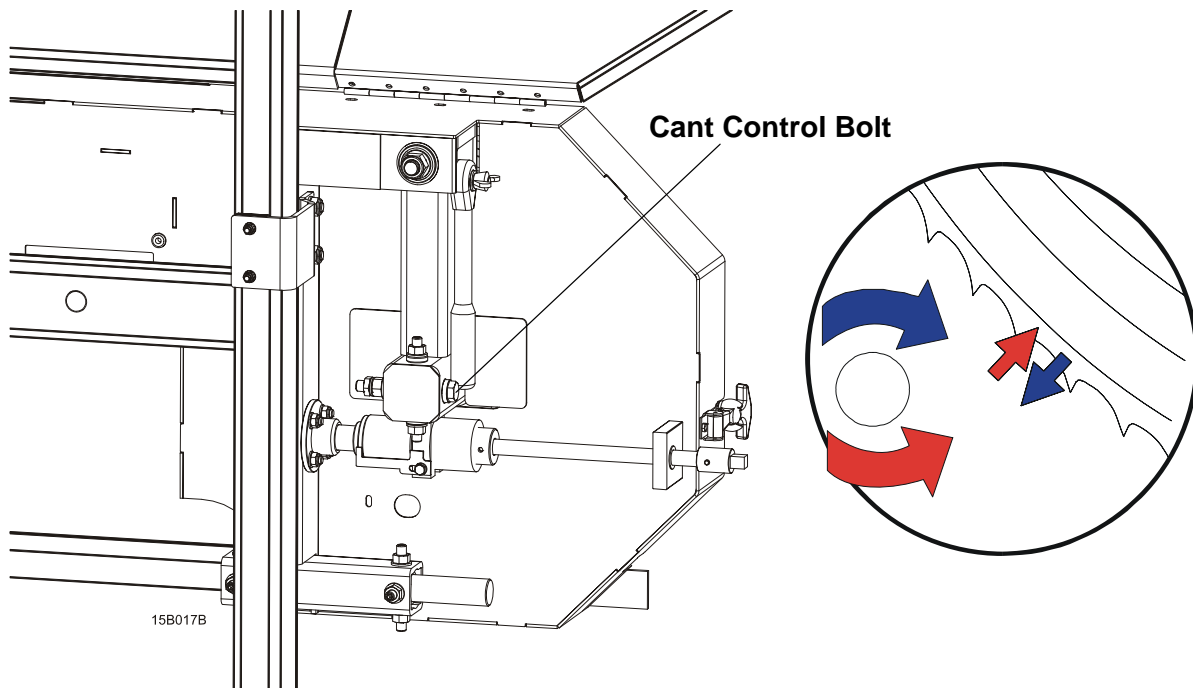

FIG. 2-5

If the blade is too far out, back the blade onto the wheel by turning the cant control counterclockwise. If the blade is too far in, turn the cant control clockwise until the gullet of the blade is the correct distance from the front edge of the wheel.

6. Adjust the blade tension if necessary to compensate for any changes that may have occurred while adjusting the cant control.
7. Close the blade housing cover.



CAUTION! Make sure all guards and covers are in place and secured before operating or towing the resaw. Failure to do so may result in serious injury. Be sure the blade housing cover is in place and secured.

NOTE: After aligning the blade on the wheels, always check the blade guide spacing and location.

2.6 Tilt Adjustment

See **Figure 2-6**. The saw head may be tilted to produce siding. Loosen the locking bolt. Turn the tilt adjustment screw clockwise to tilt the saw head upward or counterclockwise to tilt the saw head downward.

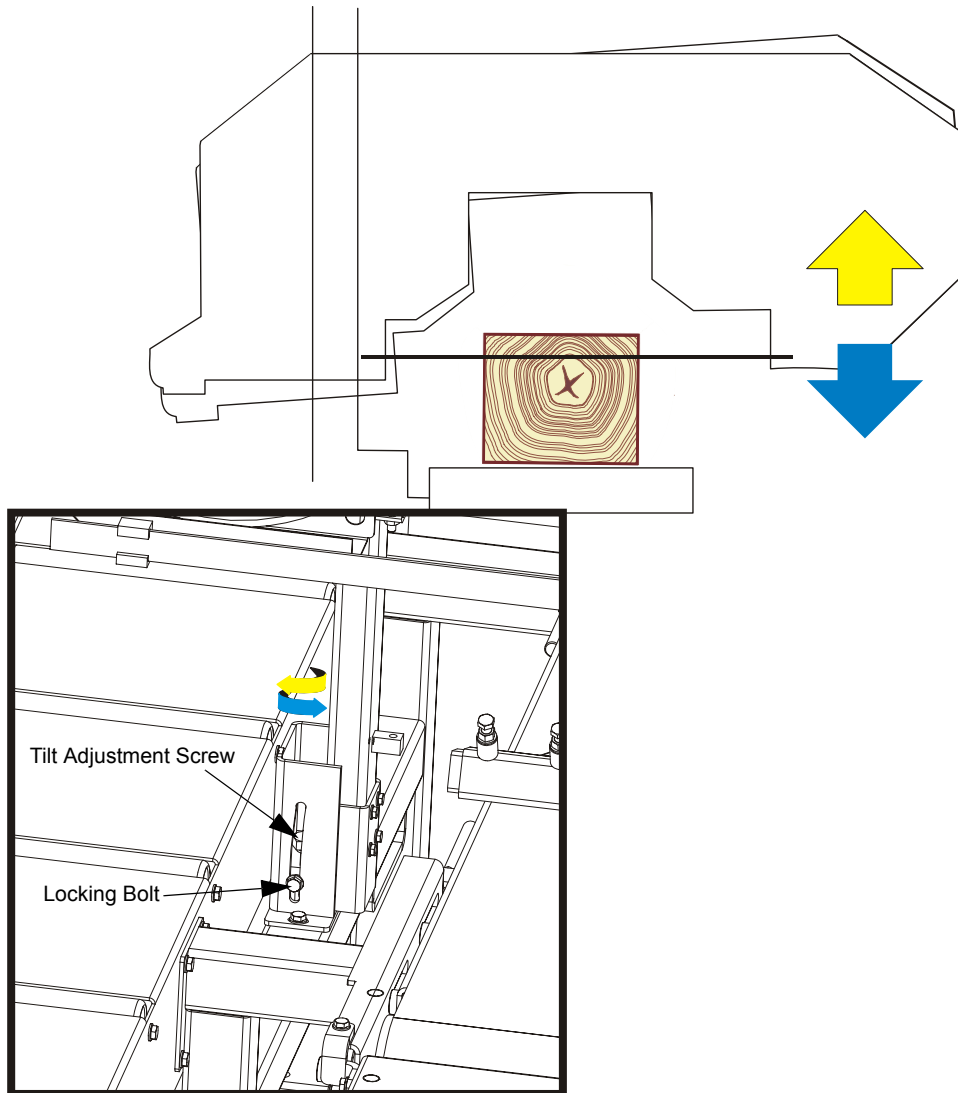



FIG. 2-6

NOTE: The saw head can be set at an angle ranging from 0° to 6°.

2.7 Machine Start

 **DANGER!** Before starting the resaw, perform these steps to avoid injury and/or damage to the equipment:

- Close the blade housing cover and replace any guards removed for service.
- Check the feed track and remove all loose objects such as tools, wood, etc.
- Check that the blade is properly tensioned.
- Make sure all persons are a safe distance from the machine.
- Check that the emergency stops are released.

NOTE: The resaw will not start if either of the emergency stops is on.

Before starting the saw head, check that the main power switch servicing the resaw is on.

See Figure 2-7. Start the blade motor. To do this, turn the key switch to the  position and then push the Blade Start button on the control panel (see the figure below). The motor should start and the blade should start spinning.

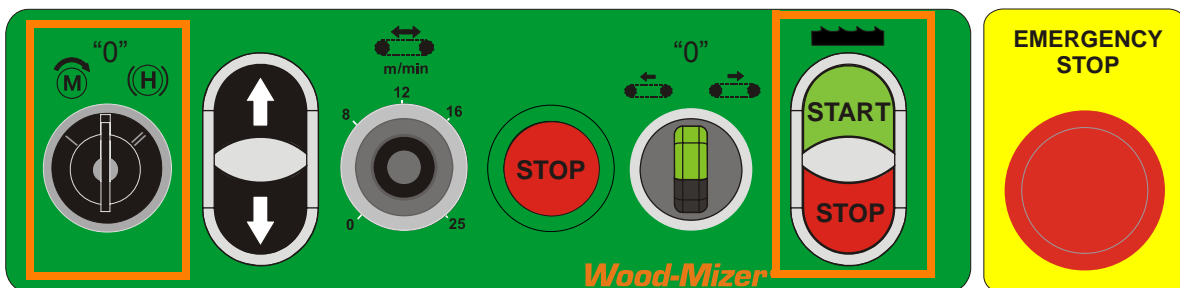

FIG. 2-7

To stop the blade motor, push the Blade/Track Stop button shown in the figure above. The blade motor also may be stopped by pushing either of the emergency stop buttons.

If either of the emergency stops has been used to stop the blade motor, rotate the switch clockwise before restarting the saw head. The saw head cannot be restarted until the emergency stop button is released.

See Figure 2-8. After the saw head has been successfully started, the feed track can be

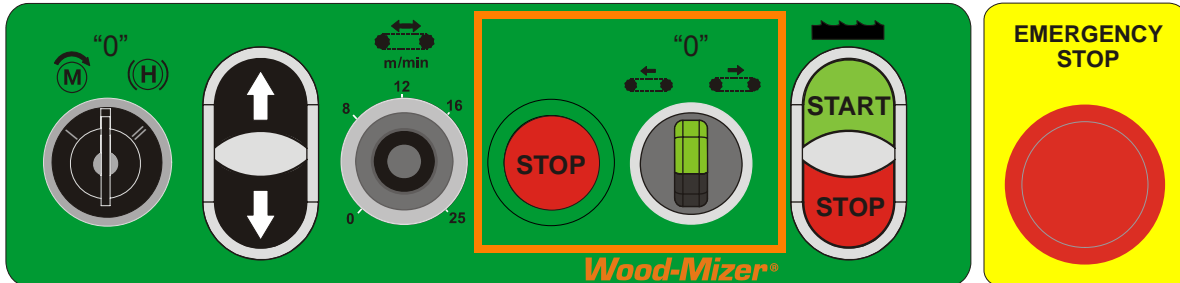

FIG. 2-8

started. To start the track chain motor, turn the Track Start switch (shown in Figure 2-6) left to start the track forward, turn the switch right to start the track backward.

The feed track can be stopped by pressing either the Stop button, shown in Figure 2-5, or one of the emergency stop buttons. The emergency stop will also stop the blade motor.

NOTE: The feed track cannot be started if the blade motor is not started.

See Figure 2-9. The speed at which the feed track moves is adjustable. The feed track

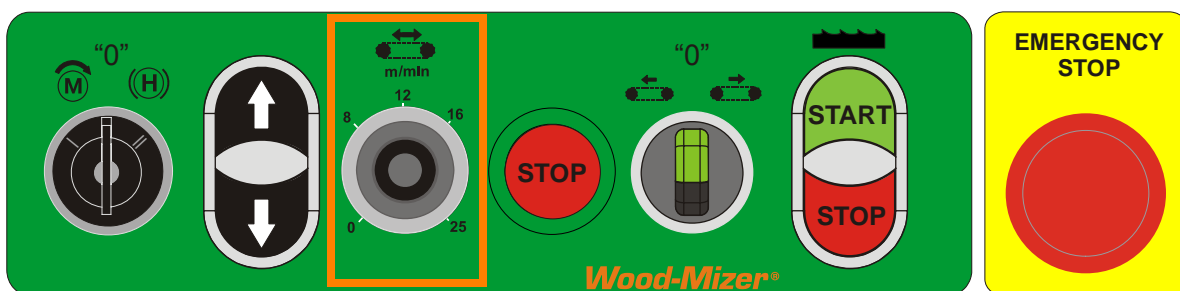

FIG. 2-9

speed switch, located on the control panel, allows the operator to adjust the feed rate from 0 to ca. 30 m per minute.

Turn the switch clockwise to increase the feed rate, counterclockwise to slow the feed rate down.

See Figure 2-10. To raise the saw head press up button. To lower the saw head press down button.

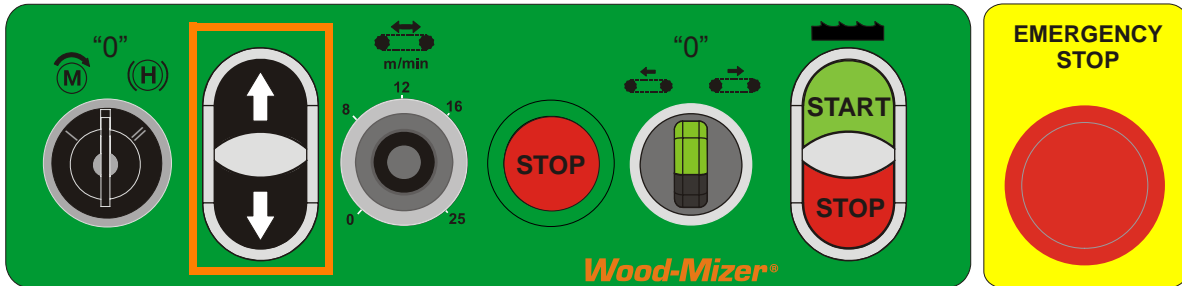

FIG. 2-10

Factors that will determine what feed rate you can use include:

- Width of material to be cut. Eight-inch material will require a slower feed rate than 1" material.
- Hardness of material to be cut. Some woods that are seasoned or naturally very hard will require slower feed rates.
- Sharpness of blades. Dull or improperly sharpened blades will require slower feed rates than sharp and properly maintained blades.
- Off-bearing capability. Your ability to feed end-to-end will also determine what feed rate you can use.

2.8 Water Lube Operation

See **Figure 2-11**. The Water Lube System keeps the blade clean. Water flows from a 5-gallon (18.9 liter) bottle through a hose to the blade guide where the blade enters the log. A valve in the bottle cap controls the amount of water flow.

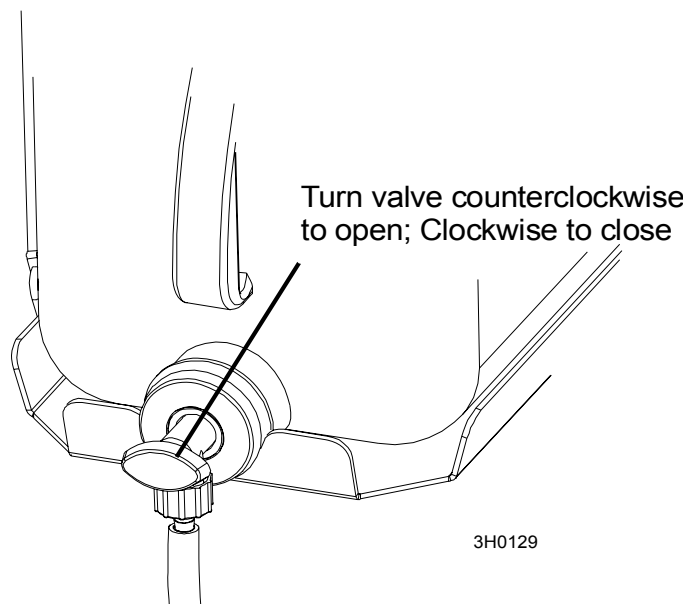

FIG. 2-11

Not all types of wood require the use of the Water Lube System. When it is needed, use just enough water to keep the blade clean. This saves water, and lowers the risk of staining the boards with water. Usual flow will be 1-2 gallons (3.8-7.6 liters) per hour (on average, the bottle content is sufficient for 4-hour-long cutting). A squirt of liquid dishwashing detergent in the water bottle will help clean the blade when cutting wood with a high sap content. Before you start cutting, check the water level in the bottle.



WARNING! Use ONLY water with the water lube accessory. Never use flammable fuels or liquids. If these types of liquids are necessary to clean the blade, remove it and clean with a rag. Failure to do so may result in serious injury or death.

Before removing the blade, start the blade motor with the START button. Let the blade spin with water running on it for about 15 seconds. This will clean the blade of sap buildup. Wipe the blade dry with a rag before storing or sharpening.

If you are sawing in freezing temperatures, remove the water lube bottle from the resaw when done sawing and store it in a warm place. Blow any remaining water from the water lube hose.

2.9 Operation Procedure

1. Install a blade if necessary.



WARNING! Always wear gloves and eye protection when handling bandsaw blades. Changing blades is safest when done by one person! Keep all other persons away from area when coiling, carrying or changing a blade. Failure to do so may result in serious injury.

2. Close the blade housing cover.
3. Tension the blade as described in [Section 2.4](#).
4. Spin the blade wheel by hand.



WARNING! Use extreme caution when spinning the blade wheel by hand. Make sure hands are clear of blade and wheel spokes before spinning. Failure to do so may result in serious injury.

5. Check alignment of the blade on the blade wheels and blade guides. Adjust as necessary.
6. Raise or lower the saw head to the desired setting.
7. Adjust the clamp roller guide to the width of material to be cut.



DANGER! Make sure all guards and covers are in place and secured before operating the resaw. Failure to do so may result in serious injury.

8. Perform pre-start check.
9. Start the blade motor.
10. Using the feed track speed switch, set the feed rate as desired.



DANGER! Always be sure all persons are out of the path of the blade before starting the motor. Failure to do so will result in serious injury.



WARNING! Always wear eye, ear, respiration and foot protection when operating or servicing your resaw.

11. Place the test material on the feed track and start the feed track.



DANGER! Always be aware of and take proper protective measures against rotating shafts, pulleys, fans, etc. Always stay a safe distance from rotating members and make sure that loose clothing or long hair does not engage rotating members resulting in possible injury.

12. Shut off the blade and feed track. Measure the finished material and adjust the saw head up or down as necessary. Repeat with the test material until the desired finished dimension is obtained.

13. Restart the blade and feed track.

14. Place material on the infeed table. Return unfinished material to be re-fed into the resaw, i.e. place it on the return table.

15. Monitor blade tension as operation continues. Adjust blade tension if required.

16. If material jam occurs, stop the blade motor and feed track.



WARNING! Allow blade to come to a complete stop before servicing. Failure to do so will result in serious injury.

17. After operation is complete, shut off the blade motor and feed track.

18. Release blade tension if done sawing for the day.



CAUTION! Remove tension from the blade when the resaw is not in use.

SECTION 3 MAINTENANCE

This section lists the maintenance procedures that need to be performed.

The Short Interval Maintenance Schedule lists procedures that need to be performed every 4, 8 or 25 hours. The Maintenance Log lists procedures that need to be performed every 50, 100, 200, or 1000 hours. Keep track of machine maintenance by filling in the machine hours and the date you perform each procedure.



This symbol identifies the interval (hours of operation) at which each maintenance procedure should be performed.

Be sure to refer to option and motor/engine manuals for other maintenance procedures.

3.1 Wear Life

See Table 3-1. This chart lists estimated life expectancy of common replacement parts if proper maintenance and operation procedures are followed. Due to the many variables which exist during sawmill operation, actual part life may vary significantly. This information is provided so that you may plan ahead in ordering replacement parts.

Part Description	Estimated Life
B57 Blade Wheel Belts	500 hours
Blade Guide Rollers	1000 hours
Drive Belt	1250 hours

TABLE 3-1

3.2 Sawdust Removal

Remove the excess sawdust from the blade wheel housing and sawdust chute every blade change.

3.3 Vertical Mast Rails



Clean and lubricate the vertical mast rails every 50 hours of operation. Clean with solvent and remove any rust with a light-grade sand paper. Lubricate the mast with motor oil or automatic transmission fluid (e.g. Dextron II or Dextron III).



CAUTION! Never use grease on the mast rails as it will collect sawdust.

3.4 Miscellaneous Lubrication

1. Lubricate the tensioner screw with a rolling bearing grease (e.g. LT4S or Shell Extreme Pressure Grease) as needed.

See Figure 3-1.

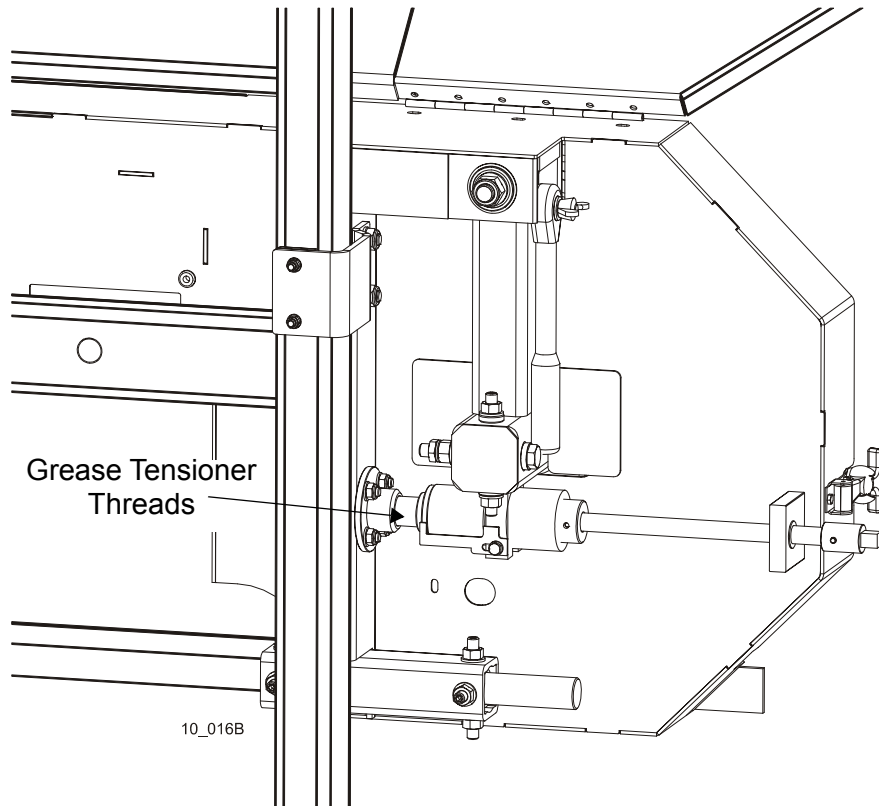

FIG. 3-2

3.5 Blade Wheel Belts

1. Rotate the blade wheel belts and check them for wear. Rotating the belts every 50 hours will give you longer belt life. Replace belts as necessary. Use only B57 belts manufactured by Goodyear or Browning.
2. Periodically check all belts for wear. Replace any damaged or worn belts as needed.

3.6 Up/Down System

1. Remove any sawdust buildup from the up/down screw bellows, the up/down screw nut, the upper and lower limit switches and the lower bearing housing.

See Figure 3-3.

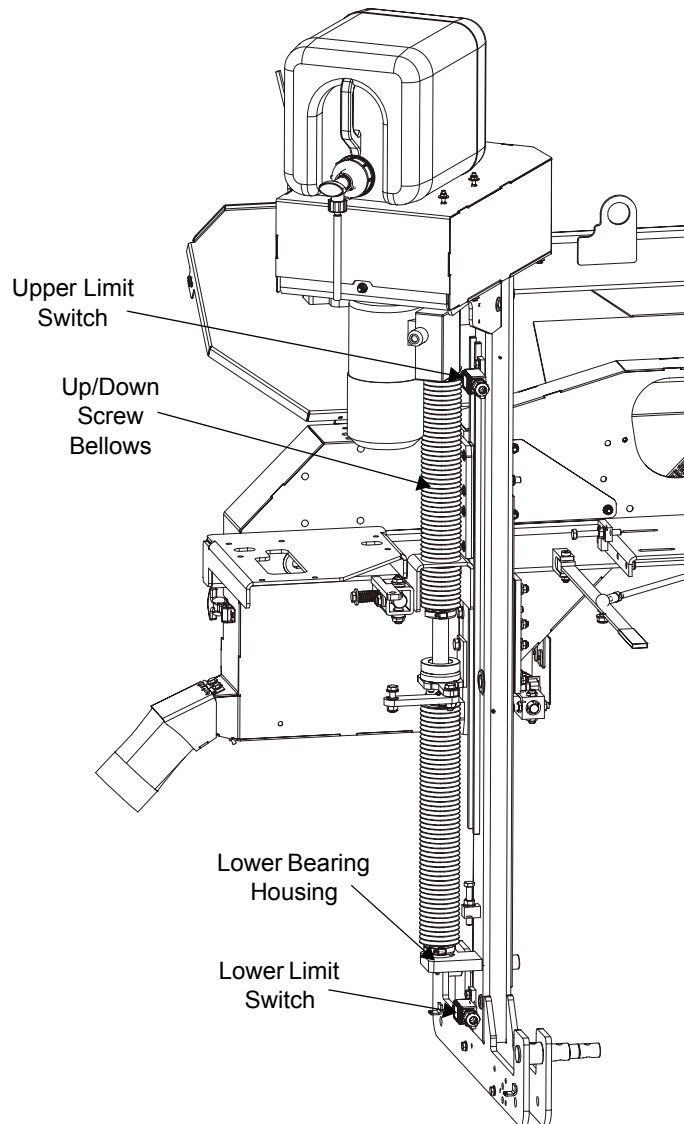

FIG. 3-4

2. Lubricate the up/down acme screw with a rolling bearing lubricant (e.g. LT4S or Shell Extreme Pressure Grease) every six months. Apply the lubricant to the grease fitting in the nut housing. Lubrication may be required sooner if environmental conditions require it. If the lubricant appears to have dispersed or is dry or crusted, reduce the maintenance interval.

The up/down screw bellows should completely cover the screw. If either of the bellows is damaged, replace it immediately. Before installing the new bellows, clean the up/down screw and nut thoroughly with extraction naphtha. The acme screw nut (Part No. 094243) should be replaced if the end play is larger than 1.25 mm.

3. Check the up/down belt tension after the first 20 hours of operation and every 100 hours thereafter.

100

See Figure 3-5. Unbolt the up/down top guard. Loosen the motor mounting bolts. Use the adjustment bolt shown below to adjust the belt tension. Tighten the motor mounting bolts. Replace the top guard.

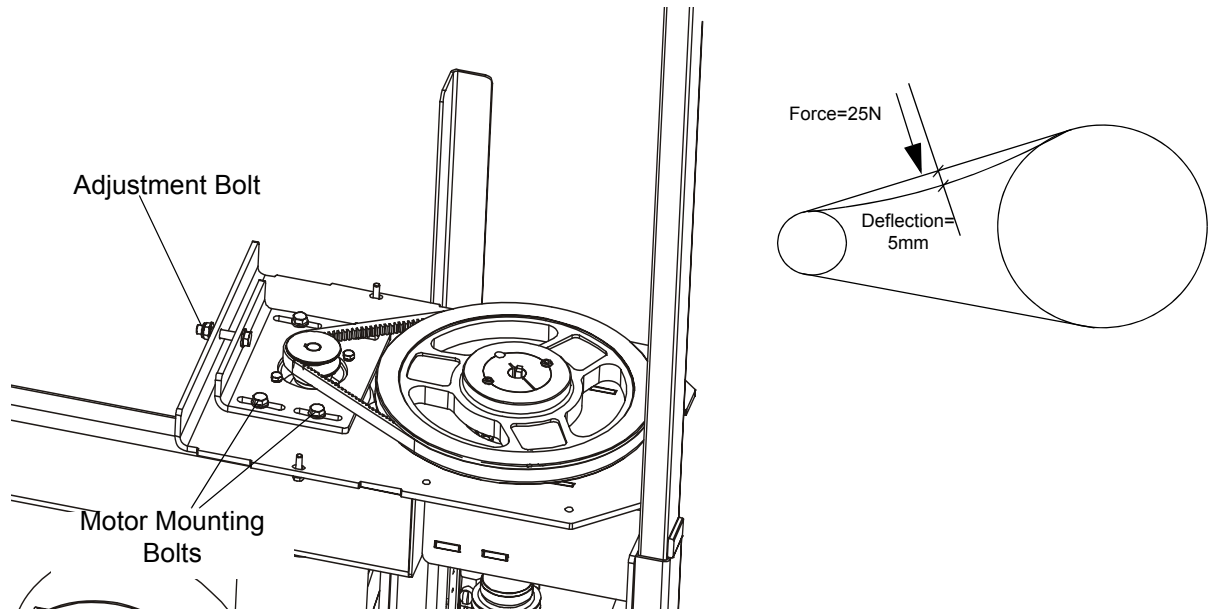

FIG. 3-6

4. Every 200 hours of operation check and adjust if necessary the up/down motor brake air gap.

200

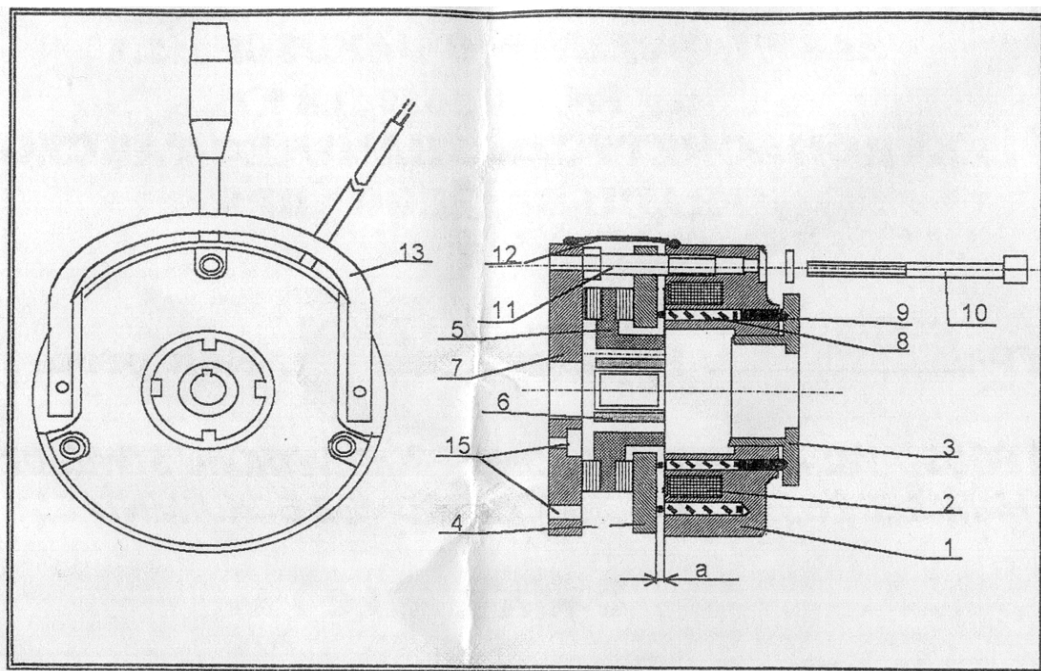

FIG. 3-7

1. Electromagnet body
2. Coil
3. Nut
4. Armature
5. Brake disk
6. Gear wheel
7. Mounting disk
8. Spring
9. Thrust pin
10. Mounting bolt
11. Adjusting bolt
12. Brake casing
13. Manual release lever
14. Locking element
15. Mounting holes

ADJUSTMENT OF AIR GAP

The air gap „a" grows gradually larger in consequence of wear of brake disc lining (5). The nominal value of the air gap „a nom" may be restored by screwing in the adjusting bolts (11). Prior to adjustment, slacken mounting bolts (10) and then set the nominal value of air gap using the feeler gauge inserted between armature (4) and body and screwing in the adjusting bolts (11). Tighten the mounting (10) and secure the position by screwing out the adjusting bolts as far as they go.

Table 1:

TYPE	HPS08
a nom.	0,2 ± 0,05
a max.	0,5

BRAKE MAINTENANCE

The brakes do not require special maintenance procedures, however during regular intervals of time depending on intensity of brake operation, perform inspections and regulation of air gap "a". When the brake disk reaches maximum wear, replace it with a new one.

While replacing the brake disk, take care that the friction surface of the disk, armature and elements cooperating with the friction linings are free from grease and oil. Remove all dirt accumulated from the brake interior. If in spite of correct mounting and proper regulation, the brake does not operate, failure is due to: electromagnet - burnt coil, damaged supply cable, rectifier system (installed in the motor terminal box or control cabinet of the machine), electrical connections - check for correctness and quality of connections, damaged elements - replace them with new ones.

3.7 Miscellaneous Maintenance

1. Check the drive belt tension after the first 20 hours, and every 50 hours thereafter. See Section 6.13 for drive belt adjustment instructions.
2. Check the mill alignment every setup. See Section 6, Alignment.
3. Make sure all safety warning decals are readable. Remove sawdust and dirt. Replace any damaged or unreadable decals immediately. Order decals from your Customer Service Representative.
4. Check the power feed system steel cable every 50 hours, replace it every 500 hours.

3.8 Drive Belt Adjustment



WARNING! Do not for any reason adjust the engine drive belts or belt support bracket with the engine running. Doing so may result in serious injury.

50

Check the drive belt tension after the first 20 hours, and every 50 hours thereafter.

The drive belt tension should be adjusted with the tensioner handle engaged (in the up position), by moving the engine assembly on the engine mount plate. To make the adjustment, perform the following steps:

1. Loosen the engine mounting bolts and the jam nuts.
2. Using the adjustment bolts, shown in the figure below, adjust the belt tension to approximately 11 mm deflection with 7.2 kG of deflection force.
3. Tighten the jam nuts and the engine mounting bolts.

See Figure 3-8.

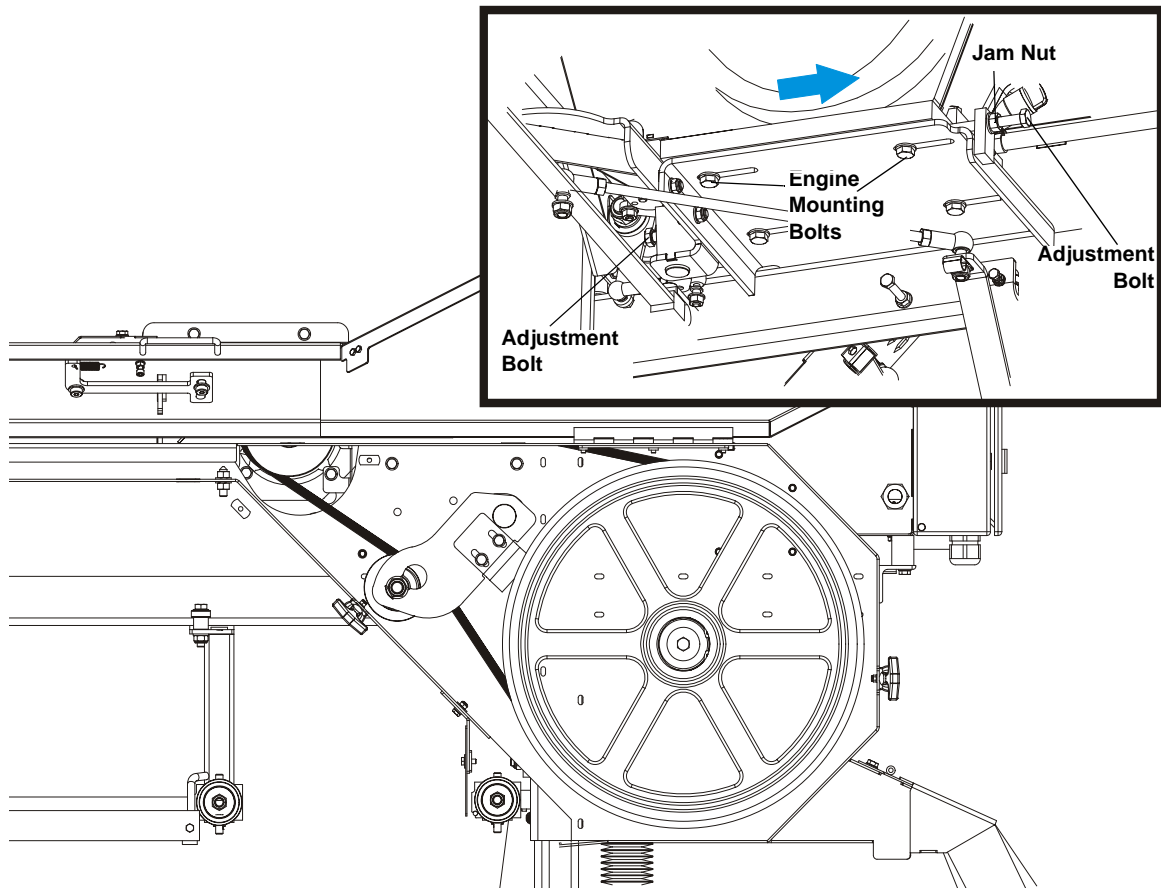

FIG. 3-8

Periodically check all belts for wear. Replace any damaged or worn belts as needed.

AR

3.9 Safety Devices Inspection

HR115 – Safety Devices Inspection

Safety devices on the HR130 resaw which must be checked before every shift:

- E-STOP button and its circuit inspection
- Red safety button inspection
- Inspection of the control circuits with the E-STOP button pressed
- Blade cover safety switch and its circuit inspection.

1. E-STOP button and its circuit inspection

- Press and hold the red safety button;
- Turn on the blade motor;
- Press the E-STOP button located on the left side of the control box. The blade motor should be stopped. Pressing the START button should not start the motor until the E-STOP button is released.

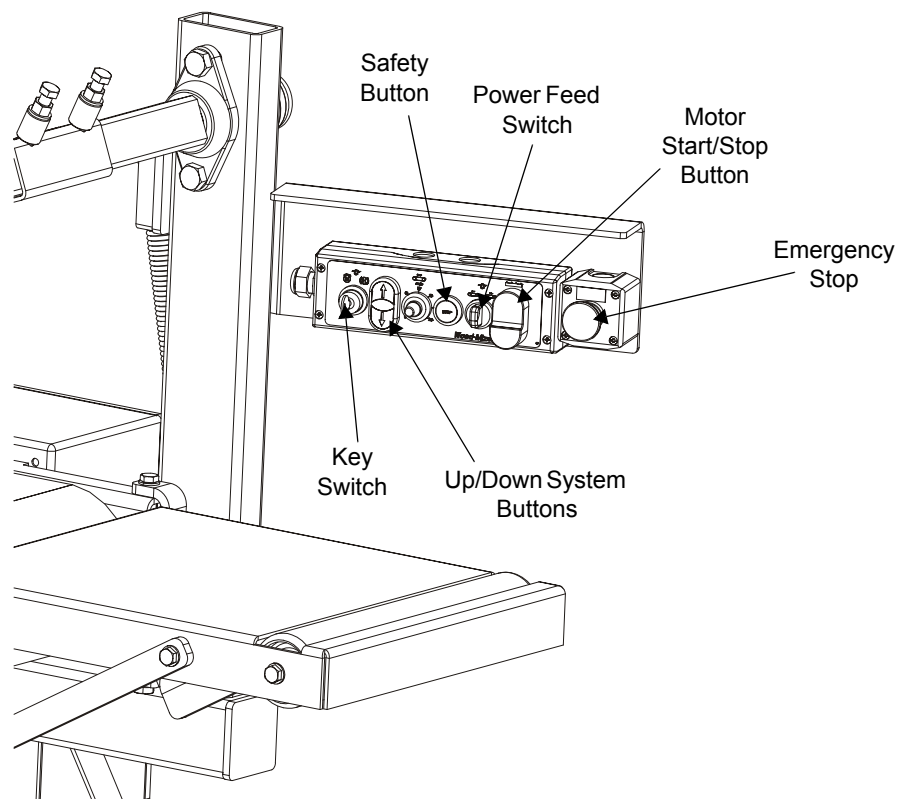

2. Red safety button inspection

- Be sure the E-STOP button is released;
- Press and hold the red safety button;
- Turn on the blade motor. The motor should be started;
- Release the safety button. The blade motor should be stopped.
- Try to start the motor without pressing the safety button. The blade motor should remain stopped.
- Press and hold the red safety button. The blade motor should remain stopped.

3. Inspection of the control circuits with the E-STOP button pressed

- Press and hold the red safety button;
- Turn on the blade motor;
- Press the E-STOP button located on the left side of the control box. The blade motor should be stopped.
- With E-STOP button pressed, try to move the saw head up and down (using the switch and the Setworks buttons) and forward/backward using the power feed switch. Both systems should not start.
- With the E-STOP button pressed, try to start the debarker blade motor and move the debarker arm in and out. The debarker should not work.

4. Blade cover safety switch and its circuit inspection

- Press and hold the red safety button;
- Turn on the blade motor;
- Open the blade housing cover;
- The blade motor should be stopped;
- Try to start the motor. The blade motor should remain stopped;
- Close the blade housing cover;
- The blade motor should remain stopped until it is restarted with the START button.

SECTION 4 ALIGNMENT

4.1 Pre-Alignment Procedures

Periodically check the sawmill alignment and adjust if necessary. This chapter explains how to align the entire sawmill. Care should be taken in performing these steps. Sawmill alignment determines the accuracy and squareness of your cuts.

The sawmill alignment steps are:

1. Prepare the sawmill for alignment
2. Adjust the blade parallel to the bed rails
3. Adjust the blade guide arm parallel to the saw head brace
4. Align blade guides to the blade
5. Adjust side supports square to the bed
6. Final Adjustments.

To insure accurate alignment, the sawmill frame must be level and a blade properly installed.

[See SECTION 3 Setup & Operation](#) for setup information.

4.2 Preparing The Sawmill For Alignment

Before performing the following alignment procedures, setup the mill on firm, level ground. String the bed and adjust the legs so the frame is level.

4.3 Blade Installation and Alignment

Install a blade and apply the appropriate tension as shown in [Section 3.3](#).

1. Close the blade housing cover and make sure all persons are clear of the open side of the saw head.
2. Start the motor for a moment.



WARNING! Do not spin the blade wheels by hand. Spinning the blade wheels by hand may result in serious injury.

3. Turn off the motor, open the blade housing cover, remove the key from the key switch (or turn off the power supply using the switch on the electric box) and check the position of the blade on the blade wheels.

Check the vertical alignment of the idle-side blade wheel. The gullet of the blade should ride the same distance from the front edge of the wheel at the top and bottom of the wheel. If it does not, loosen and tighten the appropriate adjustment screws on the wheel shaft.

See Figure 4-1. The blade wheels should be adjusted so that the gullet of 1 1/4" blades ride 1/8" (3 mm) out from the front edge of the wheels ($\pm 1/26$ [1 mm]). The gullet of 1 1/2" blades should ride 3/16" (4.5 mm) from the front edge of the wheels ($\pm 1/26$ [1 mm]). Do not let the teeth ride on the wheels.

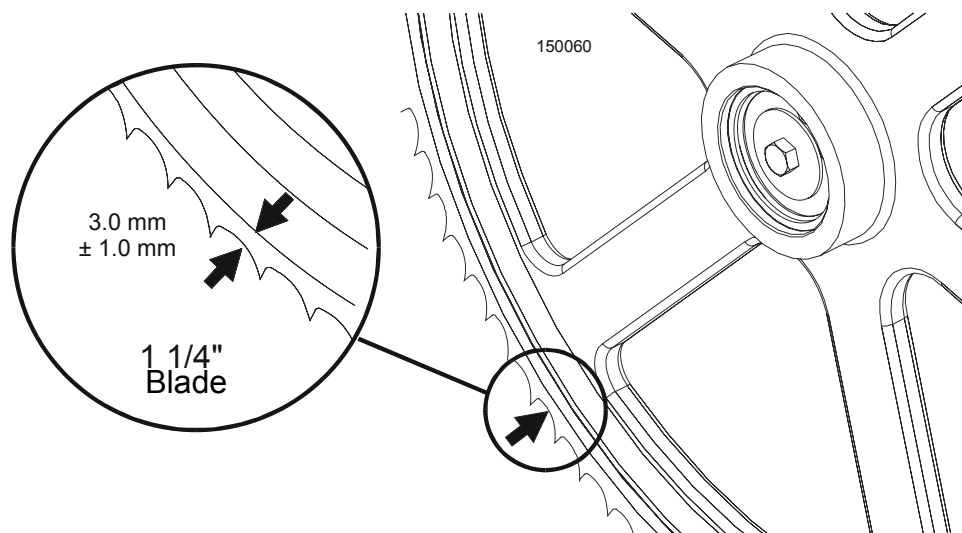

FIG. 4-1

To adjust where the blade travels on the idle-side and drive-side blade wheel, [See Section 4.4.](#)

4.4 Blade Wheel Alignment

The blade wheels should be adjusted so they are level in the vertical and horizontal planes. If the blade wheels are tilted up or down, the blade will want to travel in the tilted direction. If the blade wheels are tilted horizontally, the blade will not track properly on the wheels.

1. Use the blade guide alignment tool to check the vertical alignment of each blade wheel. Attach the tool to the blade near the inner blade guide mount. Be sure the tool does not rest on a tooth or burr, and is lying flat against the bottom of the blade.

See Figure 4-2.

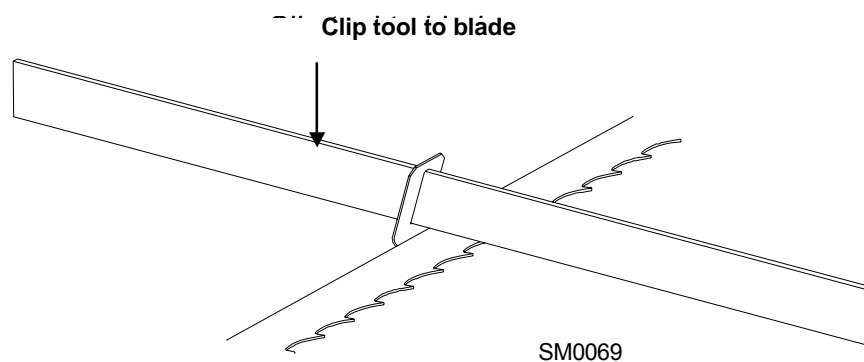

FIG. 4-2

2. Move the saw carriage so the front end of the tool is positioned over the first bed rail. Measure from the bottom of the tool to the top surface of the bed rail.
3. Move the saw carriage so the rear of the tool is positioned over the bed rail. Again, measure from the bottom of the tool to the bed rail.
4. If the two measurements differ by more than 1/16" (1.5 mm), adjust the vertical tilt of the drive-side blade

wheel.

See Figure 4-3. Use the vertical adjustment screws to adjust the drive-side blade wheel. To tilt the wheel, loosen the top adjustment screw one quarter turn. Loosen the jam nut on the bottom adjustment screw and tighten the screw. Tighten the top and bottom jam nuts.

To tilt the wheel , loosen the bottom adjustment screw one quarter turn. Loosen the jam nut on the top adjustment screw and tighten the screw. Tighten the top and bottom jam nuts.

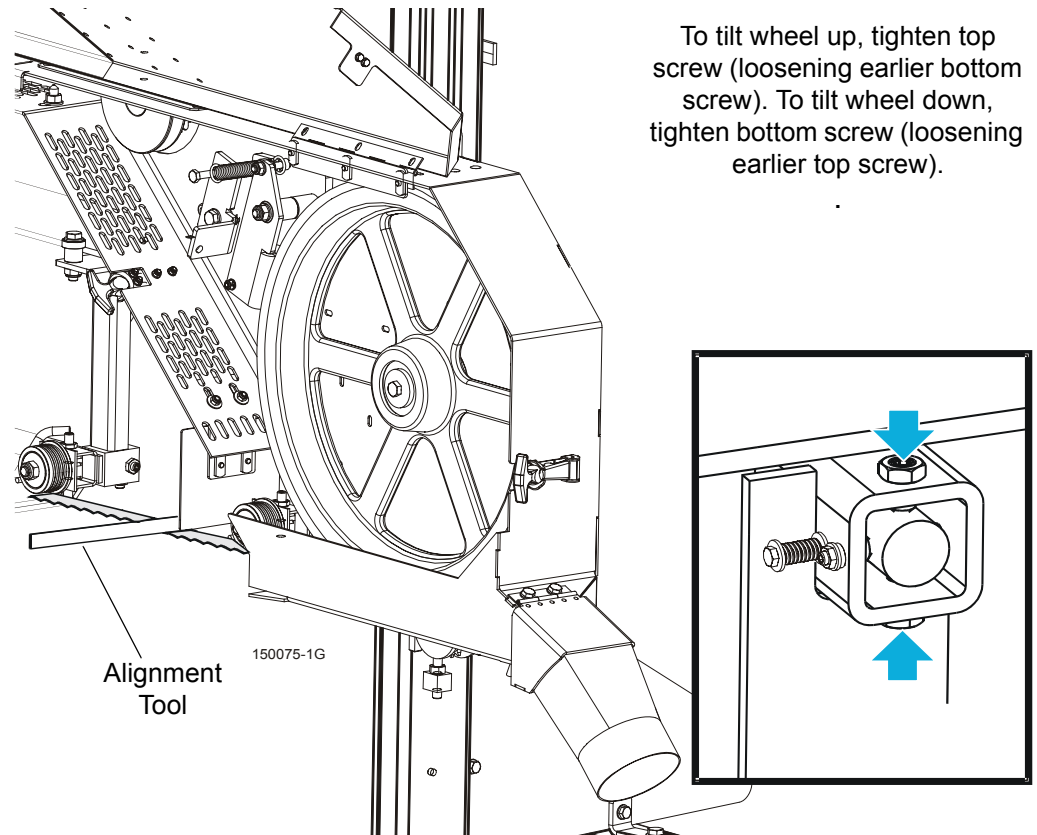

To tilt wheel up, tighten top screw (loosening earlier bottom screw). To tilt wheel down, tighten bottom screw (loosening earlier top screw).

FIG. 4-3

5. Recheck the vertical tilt of the drive-side blade wheel with the blade guide alignment tool. Readjust the blade wheel as necessary until the front and rear of the tool are the same distance from the bed rail (within 1/16" [1.5 mm]).
6. Remove the tool from the blade and reattach it near the outer blade guide assembly.
7. Measure from the tool to the bed rail at both ends of the tool. If the measurements at the front and rear ends of the tool differ by more than 1/16" (1.5 mm), adjust the vertical tilt of the idle-side blade wheel.

See Figure 4-4. Use the vertical adjustment screws to adjust the idle-side blade wheel. To tilt the wheel up, loosen the bottom adjustment screw one quarter turn. Loosen the jam nut on the top adjustment screw and tighten the screw. Tighten the top and bottom jam nuts.

To tilt the wheel down, loosen the top adjustment screw one quarter turn. Loosen the jam nut on the bottom adjustment screw and tighten the screw. Tighten the top and bottom jam nuts.

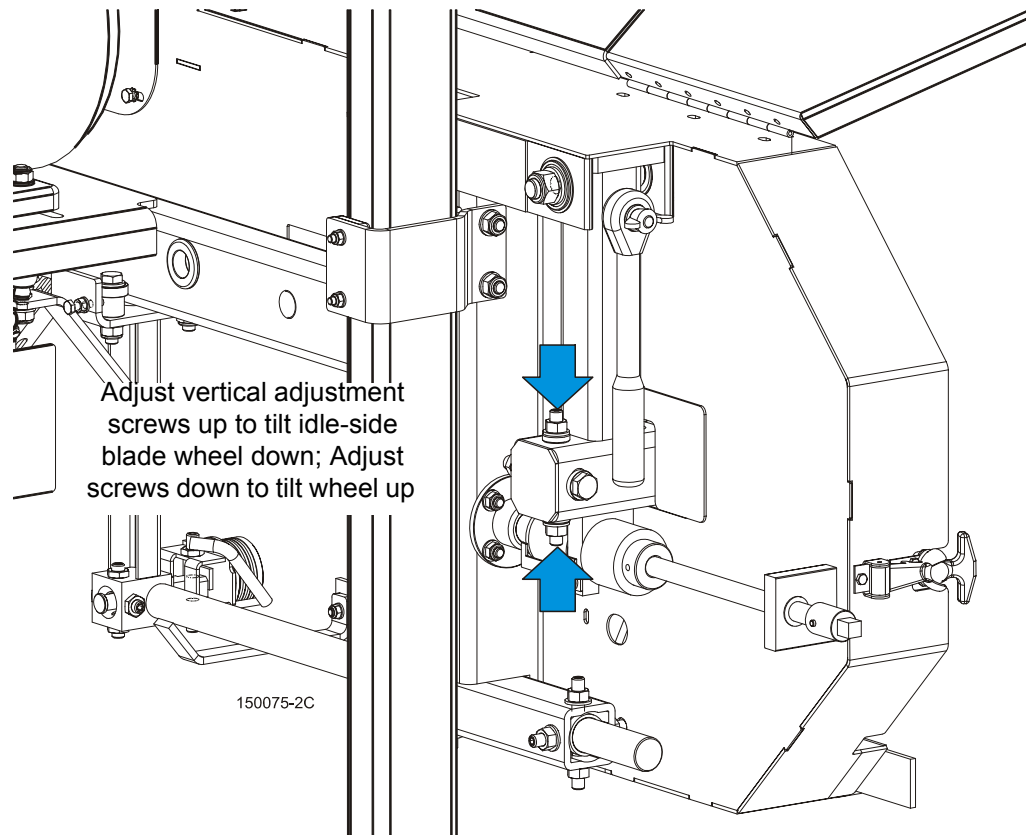

FIG. 4-4

8. Recheck the vertical tilt of the idle-side blade wheel with the blade guide alignment tool. Readjust the blade wheel as necessary until the front and rear of the tool are the same distance from the bed rail (within 1/16" [1.5 mm]).
9. Check the position of the blade on the idle-side blade wheel.

See Figure 4-5. The horizontal tilt of the blade wheel should be adjusted so that the gullet of an 1-1/4" blade is 1/8" (3 mm) out from the front edge of the wheel ($\pm 1/32$ [0.75 mm]).

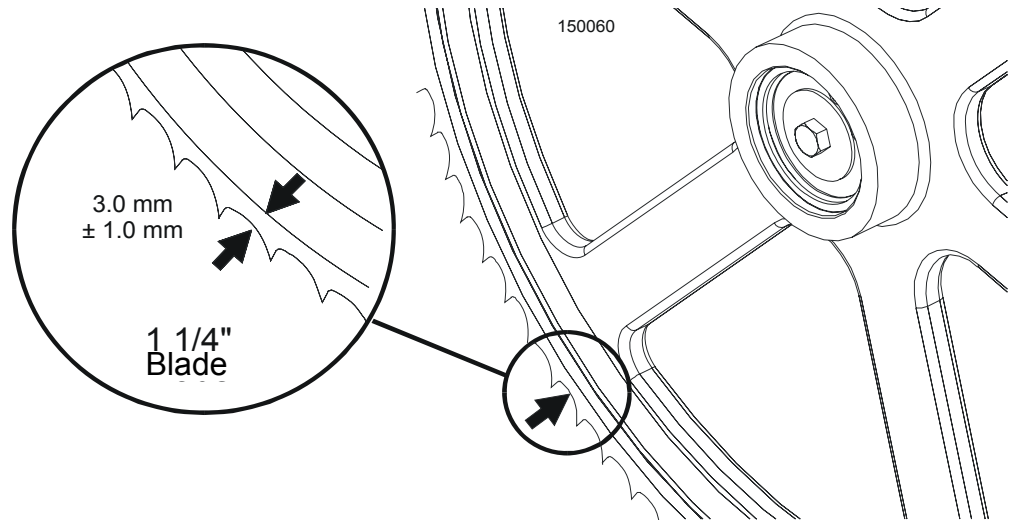

FIG. 4-5

See Figure 4-6. Use the cant control adjustment to adjust the idle-side blade wheel. If the blade is too far forward on the wheel, turn the cant control counterclockwise. If it is too far back on the wheel, turn the cant control clockwise.

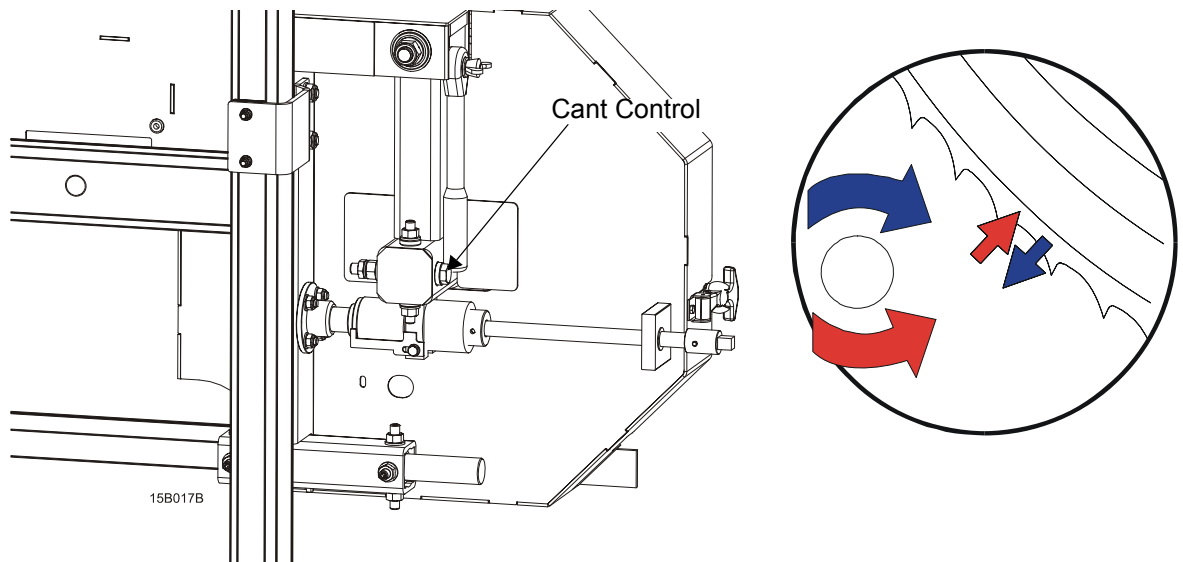

FIG. 4-6

10. Check the position of the blade on the drive-side blade wheel. The blade should be positioned on the wheel as described for the idle-side blade wheel. Adjust the drive-side blade wheel if necessary.

See Figure 4-7. Use the horizontal adjustment screw to adjust the drive-side blade wheel. Loosen the jam nut on the adjustment screw. Loosen adjustment screw to move blade out on wheel. Tighten adjustment

screw to move blade in on wheel. Tighten the jam nut.

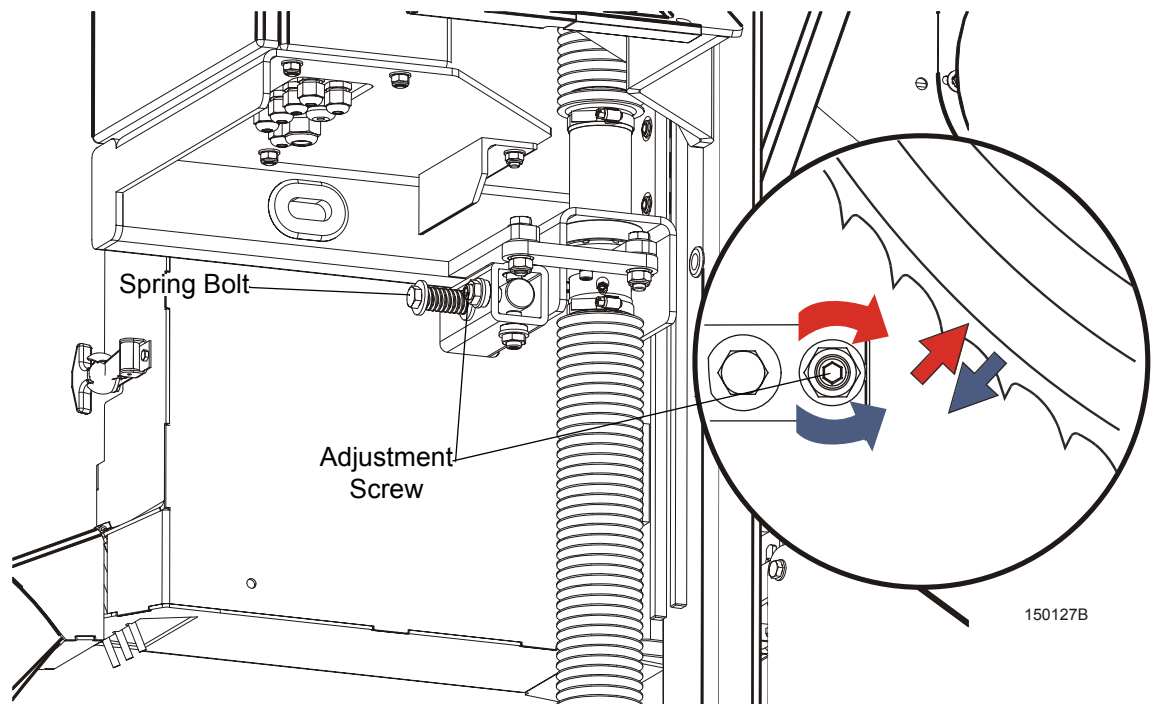

FIG. 4-7

NOTE: It is not necessary to align the spring bolt (bolt M10x75 [WM# F81003-15] + spring + washer) shown in the figure above. When replacing the bolt or spring just screw in the bolt maximally.

4.5 Blade Guide Arm Alignment

Before aligning the blade guide arm, track the blade on the blade wheels as described in [Section 3.4](#). Move the cutting head so the blade is positioned over the first bed rail. Level the blade to the bed rail as shown in [Section](#). Adjust the blade guide rollers so they do not touch the blade.

Vertical Alignment

1. Adjust the blade guide arm all the way out away from the other blade guide (maximum distance between the guide rollers).

See Figure 4-8.

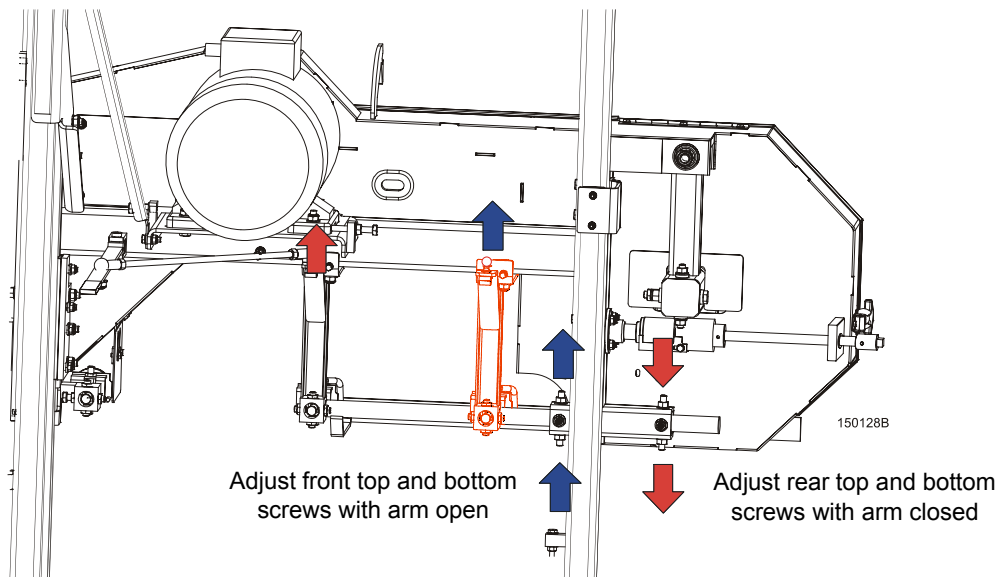

FIG. 4-8

2. Use the arm adjustment screws, marked with blue arrows in the figure above, to adjust the arm up until the slide pad touches the saw head brace tube. Tighten the jam nuts.
3. Adjust the blade guide arm in all the way toward the other blade guide (minimum distance between the guide rollers).
4. Use the arm adjustment screws, marked with red arrows in the figure above, to adjust the arm up until the slide pad touches the saw head brace tube. Tighten the jam nuts.

NOTE: When adjusting the blade guide arm screws, be careful not to damage their threads or deform the arm guide bushing. Operate the blade guide arm handle to ensure the arm moves easily left and right when the handle is moved.

Horizontal Alignment

See Figure 4-9.

1. With the blade guide arm still all the way in toward the other blade guide, tighten all the side screws until they touch the arm. Back the screws off 1/4 turn and tighten the jam nuts.
2. Sight across the horizontal saw head brace to view the blade guide arm. Adjust all side screws on the blade guide arm housing so the arm is parallel to the saw head brace.
3. To move the blade guide end of the arm toward the front of the sawmill, loosen jam nuts on the front inside screw and the rear outside screw. Turn the screws counterclockwise one full turn and tighten the jam nuts. Loosen the jam nuts on the front outside screw and the rear inside screw. Turn the screws clockwise until they touch the arm, back off 1/4" turn, and tighten the jam nuts.
4. To move the blade guide end of the arm toward the rear of the sawmill, loosen jam nuts on the front outside screw and the rear inside screw. Turn the screws counterclockwise one full turn and tighten the jam nuts. Loosen the jam nuts on the front inside screw and the rear outside screw. Turn the screws clockwise until

they touch the arm, back off 1/4" turn, and tighten the jam nuts.

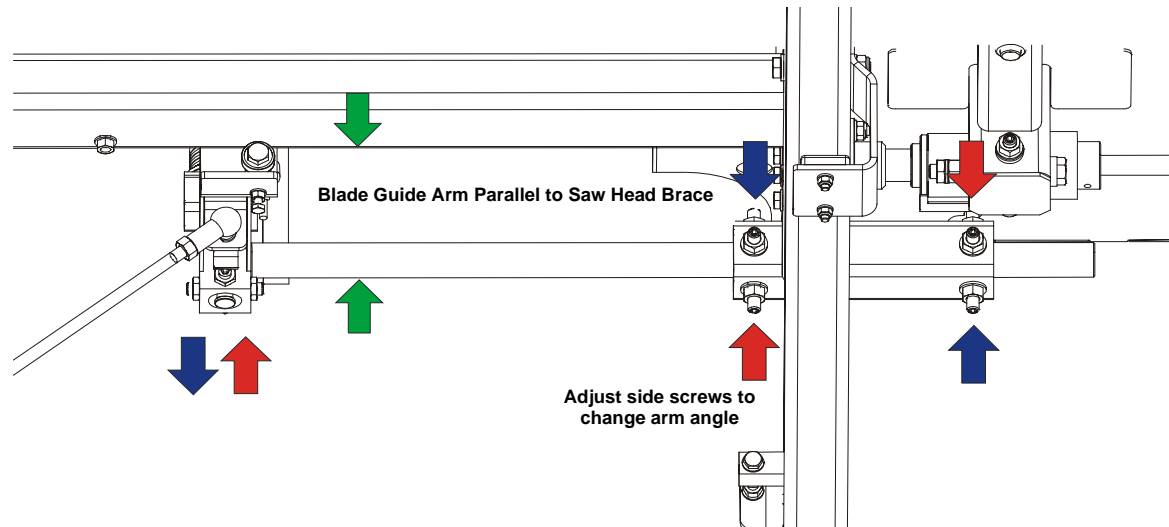

FIG. 4-9

4.6 Aligning The Blade Guides

Each Wood-Mizer sawmill has two blade guide assemblies that help the blade maintain a straight cut. The two blade guide assemblies are positioned on the saw head to guide the blade on each side of the material being cut.

One blade guide assembly is mounted in a stationary position on the drive side of the saw head. This assembly is referred to as the "inner" blade guide assembly.

The other blade guide assembly is mounted on the idle side of the saw head. It is referred to as the "outer" assembly and is adjustable for various widths of materials to be processed.

Blade guide alignment includes four steps:

- Blade Deflection
- Blade Guide Vertical Tilt
- Blade Guide Flange Spacing
- Blade Guide Horizontal Tilt

Perform the blade guide alignment after you have aligned the blade on the wheels and adjusted the blade and blade guide arm parallel to the bed rails. After blade guide alignment, check the scale indicator to make sure it is adjusted properly.

4.7 Blade Deflection

Perform the following steps to achieve proper blade deflection with the blade guides.

1. Raise the carriage until the blade is 15" (375 mm) above a bed rail. Measure the actual distance with a tape from the top of the rail to the bottom of the blade.

See Figure 4-10.

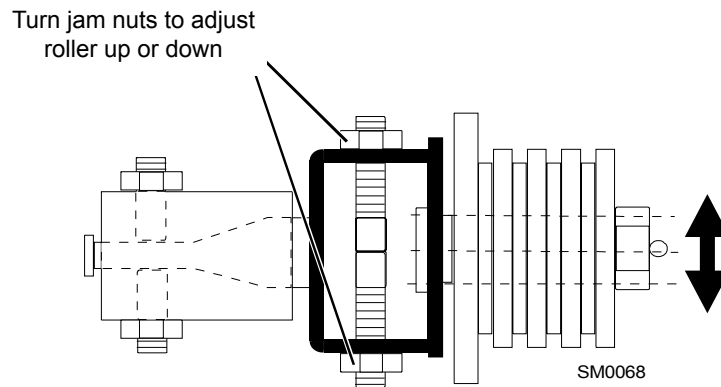

FIG. 4-10

2. Loosen the bottom jam nut and tighten the top jam nut until the blade guide deflects the blade down 1/4" (6 mm).
3. Repeat for the other blade guide.

NOTE: Be sure that the blade guard clears the blade on both guide assemblies. The guard on the outer guide assembly should be checked with the arm all the way in and all the way out.

4.8 Blade Guide Vertical Tilt Adjustment

Check that the blade guide does not tilt the blade up or down. A Blade Guide Alignment Tool (BGAT) is provided to help you measure the vertical tilt of the blade.

1. Open the adjustable blade guide arm 1/2" (15 mm) from full open.
2. Clamp the alignment tool on the blade. Position the tool close to a blade guide roller. Be sure the tool does not rest on a tooth or burr, and is lying flat on the blade.

See Figure 4-11.

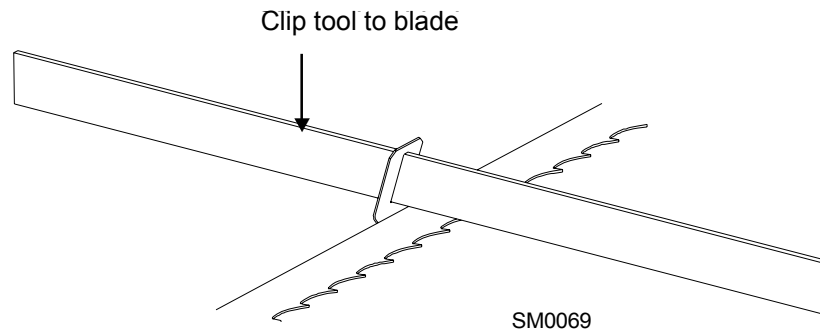

FIG. 4-11

3. Measure the distance from the bed rail to the bottom of the tool.
4. Move the carriage so that the front end of the tool is positioned above the bed rail.
5. Measure the distance from the bed rail to the bottom edge of the tool.
6. Loosen one set screw at the side of the blade guide assembly.
7. Use the set screws shown to tilt the blade guide until the measurement from the bed rail to the tool equals the first measurement taken at the center of the tool.

See Figure 4-12.

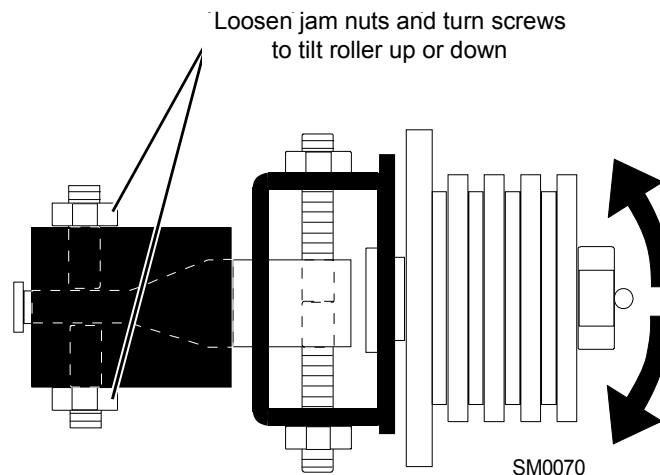

FIG. 4-12

8. Move the carriage forward so the back end of the tool is over the bed rail.
9. Use the set screws shown to adjust the blade guide tilt until the measurement from the bed rail to the tool equals the other two measurements taken.
10. Move the tool close to the other blade guide and repeat the previous steps.

NOTE: If major adjustments to blade guide tilt were made, remeasure the distance between the blade and the bed rails to ensure the correct 1/4" (6.5 mm) blade guide deflection. Adjust if necessary.

4.9 Blade Guide Spacing

HINT: When adjusting blade guide spacing, loosen the top set screw and one side set screw only. This will insure horizontal and vertical tilt adjustments are maintained when the set screws are retightened.

1. Adjust the inner blade guide so the blade guide flange is approximately 1/16" - 1/8" (1.5 - 3.0 mm) from the back of the blade.
2. Loosen one side and one top set screw shown. Tap the blade guide forward or backward until properly positioned.

See Figure 4-13.

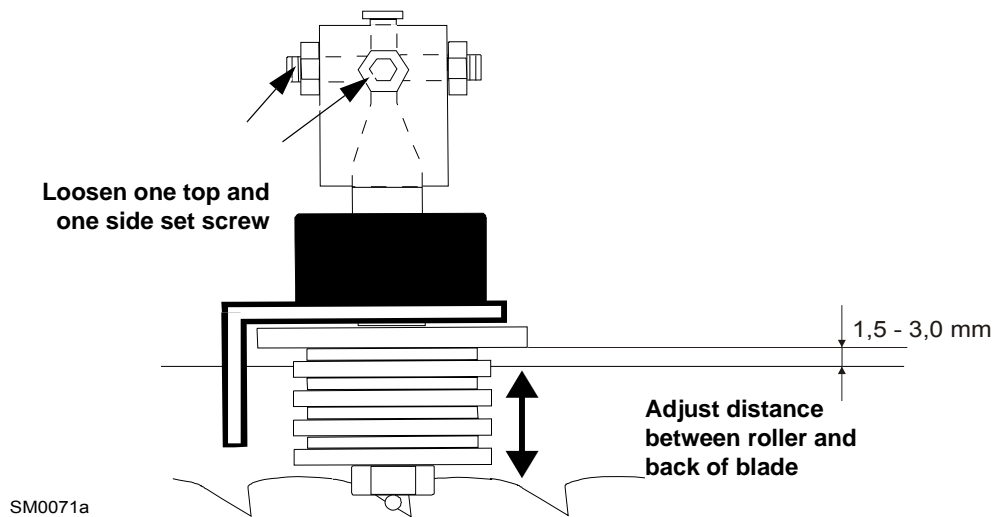

FIG. 4-13

3. Retighten the two set screws.
4. Adjust the outer blade guide in the same way so the blade guide flange is approximately 1/16" - 1/8" (1.5 - 3.0 mm) from the back of the blade.

NOTE: After adjusting the spacing of the rollers, start the blade motor for a moment. Then stop the blade and check the spacing again.

4.10 Horizontal Tilt Adjustment

1. Finally, both blade guides must be tilted horizontally. Adjust the blade guide arm half way in.

See Figure 4-14.

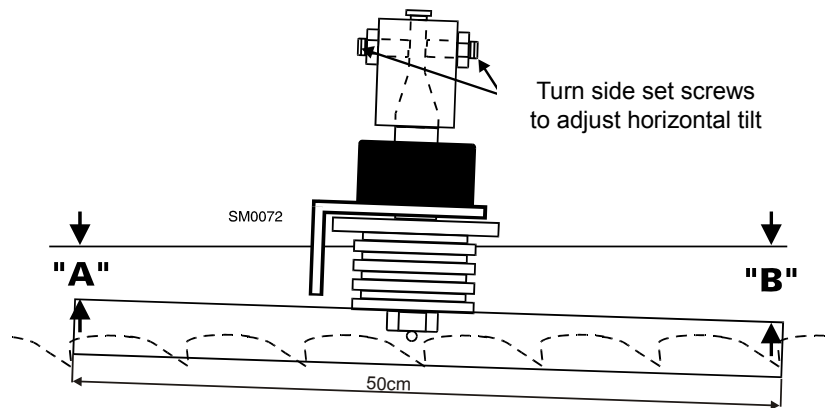

FIG. 4-14

2. Place Blade Guide Alignment Tool against the face of the outer blade guide roller.
3. Center the tool on the roller and measure between the back edge of the blade and the ruler at the end closest to the inner blade guide ("B").
4. Measure between the back edge of the blade and the other end of the ruler ("A").
5. The roller should be parallel to the blade ($A=B$) or tilted slightly to the left ($A=B-1/4$ [6 mm]).
6. Use the side set screws to adjust the horizontal tilt of the roller.
7. Repeat Steps 3 - 7 for the inner blade guide roller.

NOTE: Once the blade guides have been adjusted, any cutting variances are most likely caused by the blade. See **Blade Handbook, Form #600**.

4.11 Blade Height Scale Adjustment

After the entire sawmill has been aligned and all adjustments made, check that the blade height scale indicates the true distance from the blade to the bed rails.

1. The maximum distance between the scale and the scale indicator should be 5 mm. If it is different, loosen the indicator bracket mounting bolts and move the bracket in the horizontal plane until the correct distance is obtained. Retighten the bracket mounting bolts.
2. Move the saw head so the blade is positioned directly above one of the bed rails. Measure from the bottom edge on a down-set tooth of the blade to the top of the bed rail.

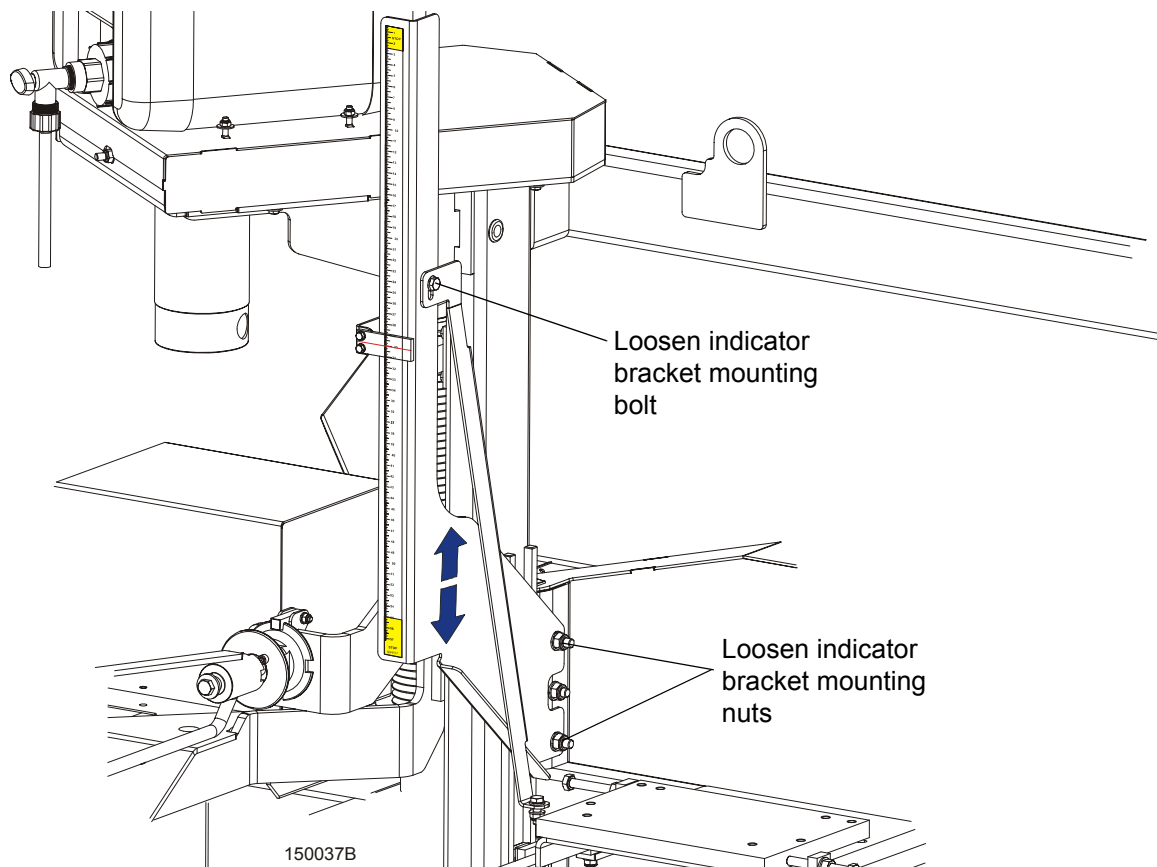

FIG. 4-14

3. Loosen the scale bracket mounting bolt and nuts, adjust the bracket until the indicator is aligned with the correct mark on the scale. Retighten the bracket mounting bolt and nuts.

For example, if the measurement from blade to bed rail was $14 \frac{3}{4}$ " (375 mm), make sure the indicator reads $14 \frac{3}{4}$ " (375 mm) on the scale.

4.12 Motor Drive Belt Adjustment

See Figure 4-15. Loosen the motor mounting bolts. Using the adjustment bolts shown below, adjust the drive belt until it has $7/16$ " (11 mm) deflection with a 8 lbs (3.6 kG) deflection force - in the case of E11 motor or $7/16$ " (11 mm) deflection with a 16 lbs (7.2 kG) deflection force - in the case of E15 motor. Tighten the four motor mounting bolts.

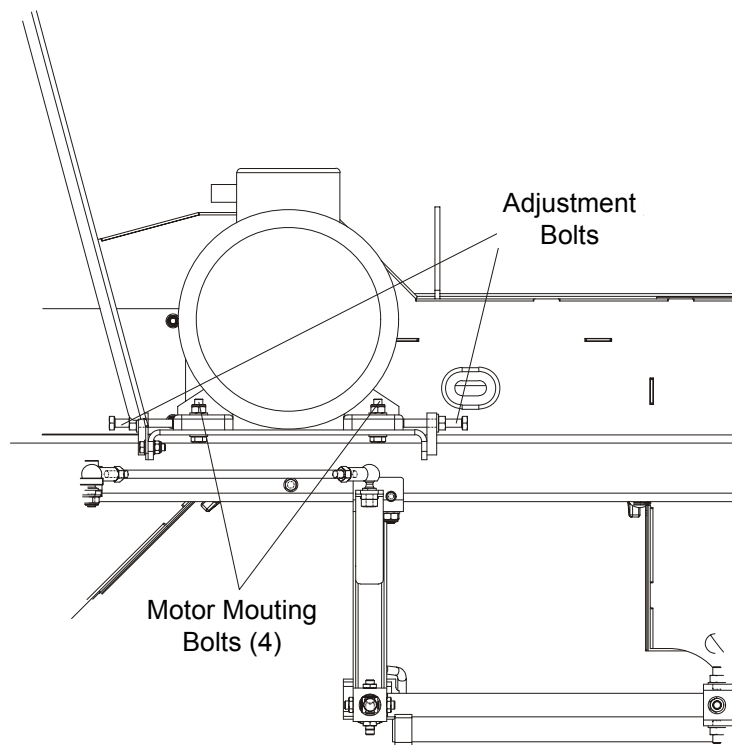

FIG. 4-15

SECTION 5 SPECIFICATIONS

5.1 Overall Dimensions

See Figure 5-1. The major dimensions of the resaw are shown below (all dimensions are in millimeters).

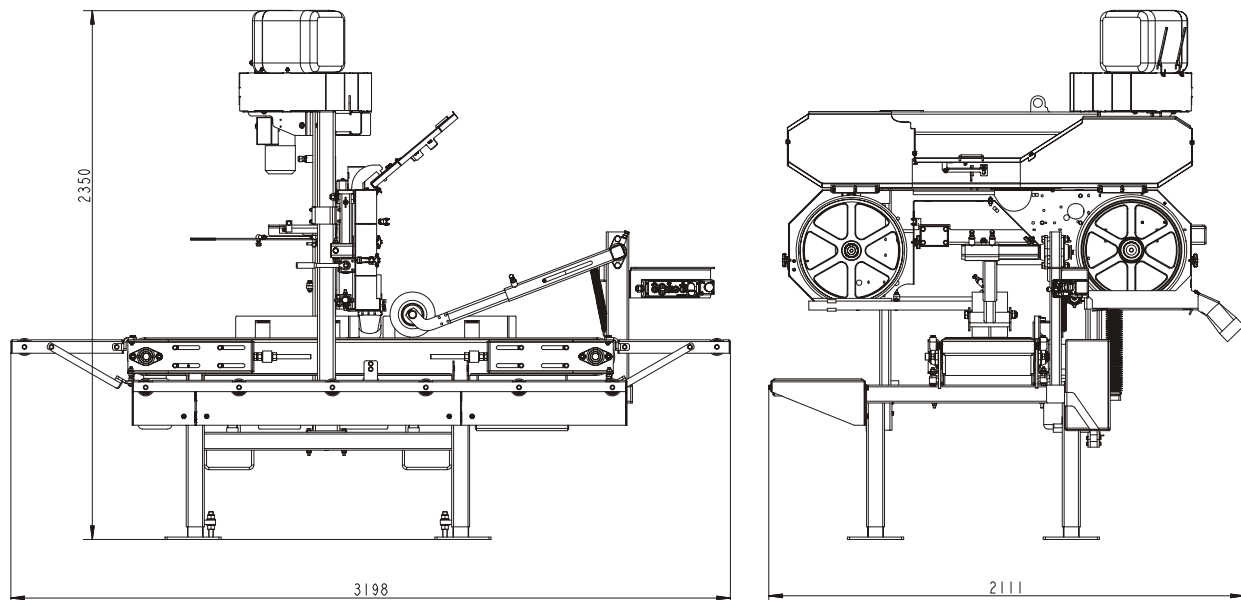

FIG. 5-1

See Table 5-1. The overall dimensions of the resaw are listed in the table below.

Weight	... kg
Height	2350 mm
Width	2111 mm
Length	3198 mm

TABLE 5-1

See Figure 5-2. The figure shows the locations of resaw legs.

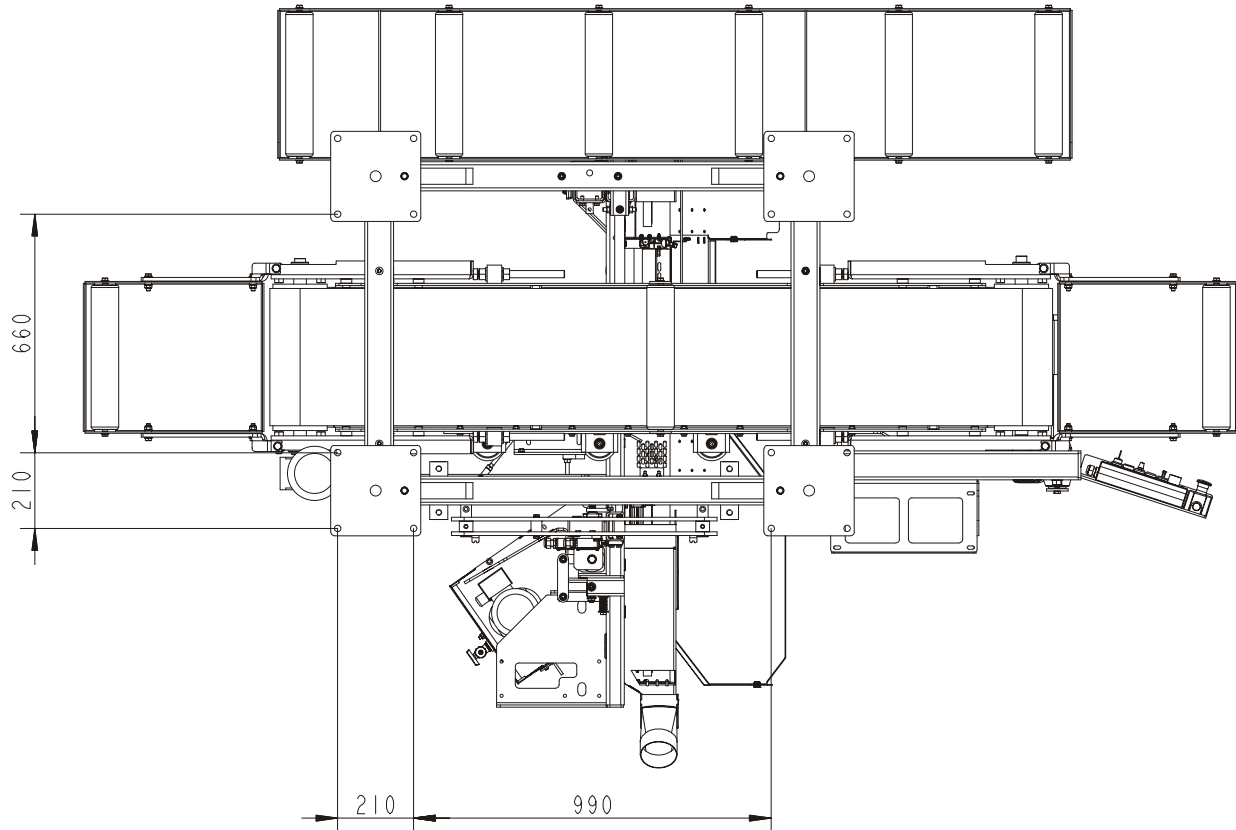

FIG. 5-2

5.2 Cutting Capacity

See Table 5-2. The material size and performance capacities of the resaw are given below.

Cutting Length	0.9 - 2.5 m
Material Height	10-400 mm
Material Width	75-400 mm
Feed Speed	0-25 m/min
Minimum Cutting Height	8 mm
Maximum Cutting Height	200 mm

TABLE 5-2

See Table 5-3. Wood-Mizer TRU•SHARP™ offers three types of blades to provide efficient sawing for all models of sawmills. The engine/motor size of your sawmill and the type of wood you saw should determine which blade you choose for optimum performance.

Engine/Motor Size	Recommended Blade For Sawing:		
	Softwood	Hardwood	Frozen or Hard-to-Cut Wood
5 hp - 15hp	B275IH1030 B275IH741030	B375IH929	B375IH929 ¹
16hp or more	B376IH1030 B376IH741030	B275IH1030 B275IH741030 B376IH1030 B376IH741030 ²	B375IH929 ¹
Electric Motor	B376IH1030 B376IH741030	B275IH1030 B275IH741030 B376IH1030 B376IH741030 ²	B375IH929 ¹

TABLE 5-3

¹ TRU•SHARP™ “F” blades use a 9/29 profile (9° hook angle and 29° back angle) and are designed to cut frozen and/or extremely dense, hard-to-cut wood. Standard TRU•SHARP™ blades use a 10/30 profile.

² Customer may choose preferred blade.

5.3 Belt Sizes

See Table 5-4. Belt sizes for the resaw are shown.

Description	Belt Size	Wood-Mizer Part #
Motor Drive Belt (E11)	B81	014819
Up/Down Drive Belt	AVX13x1030	094253
Blade Pulley Belts	B57 ¹	P04185

TABLE 5-4

¹ To insure proper blade tracking, use Goodyear, Dayco Super II, or Browning belts only.

5.4 Blade Motor Specifications

See Table 5-5. See the table below for blade motor specifications for your resaw model.

Motor Type	Manufacturer	Model	Power	Other Specifications
E11 Electric	Siemens, Germany	1LE1002 1CA13-4AA4-Z F01+F12	7.5 kW	3 x 400V, 50 Hz

TABLE 5-5

See Table 5-6. The noise levels of the Wood-Mizer resaw are listed below¹².

	Noise level
Resaw Equipped With Electric Motor	$L_{EX8} = 81,9 \text{ dB (A)}$

TABLE 5-6

1. The noise level measurement was taken in accordance with PN-EN ISO 3746 Standard . The noise exposure level given above concerns an 8-hour work day.

2. The figures quoted are emission levels and are not necessarily safe working levels. Whilst there is a correlation between the emission and exposure levels, this cannot be used reliably to determine whether or not further precautions are required. Factors that influence the actual level of exposure of the workforce include the characteristics of the work room and the other sources of noise etc. i.e. the number of machines and other adjacent processes. Also the permissible exposure level can vary from country to country. This information, however, will enable the user of the machine to make a better evaluation of the hazard and risk.

5.5 Electrical Diagram, CE version

Page 1

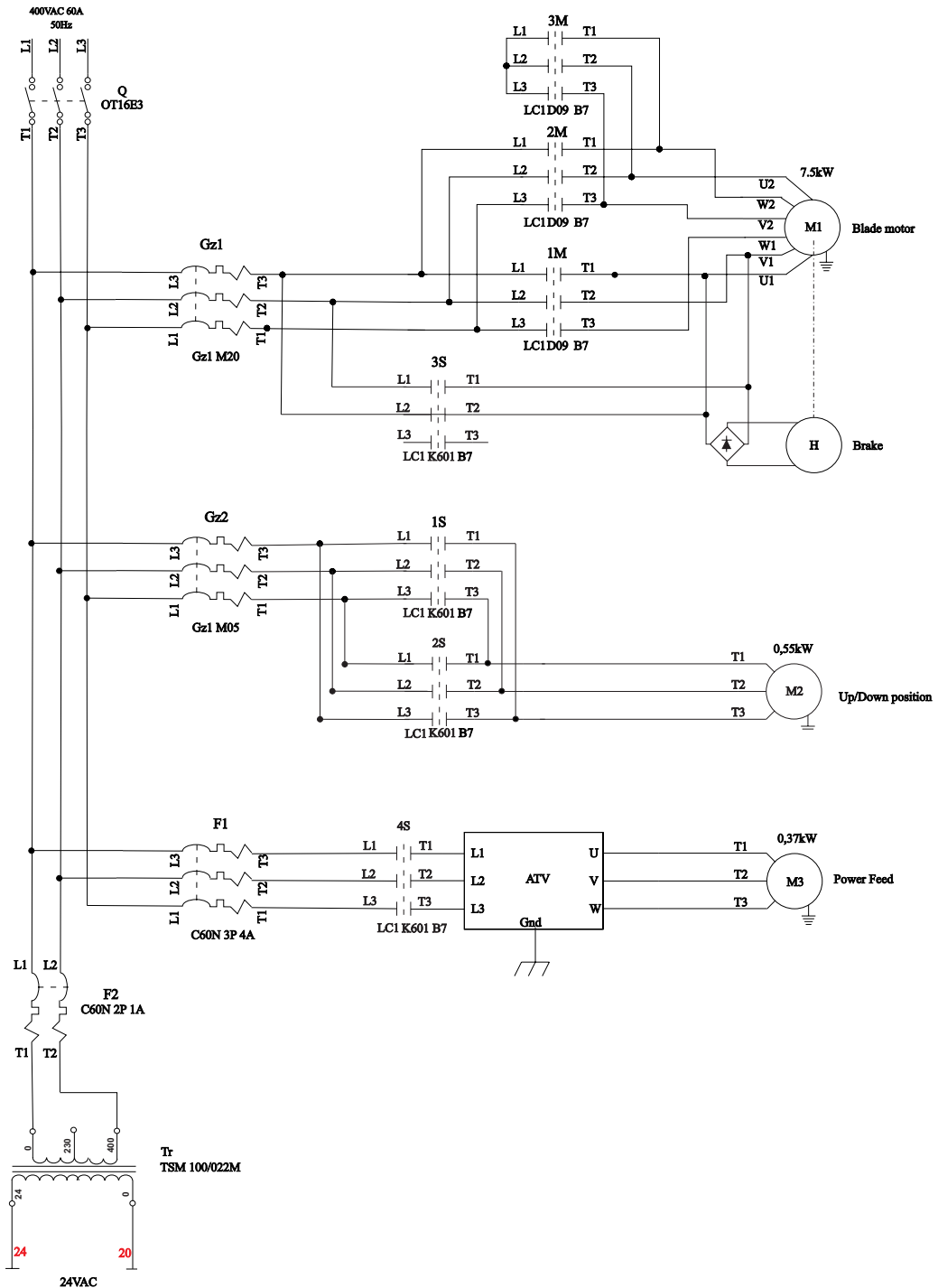

FIG. 5-2

5 Specyfikacje

Electrical Diagram, CE version

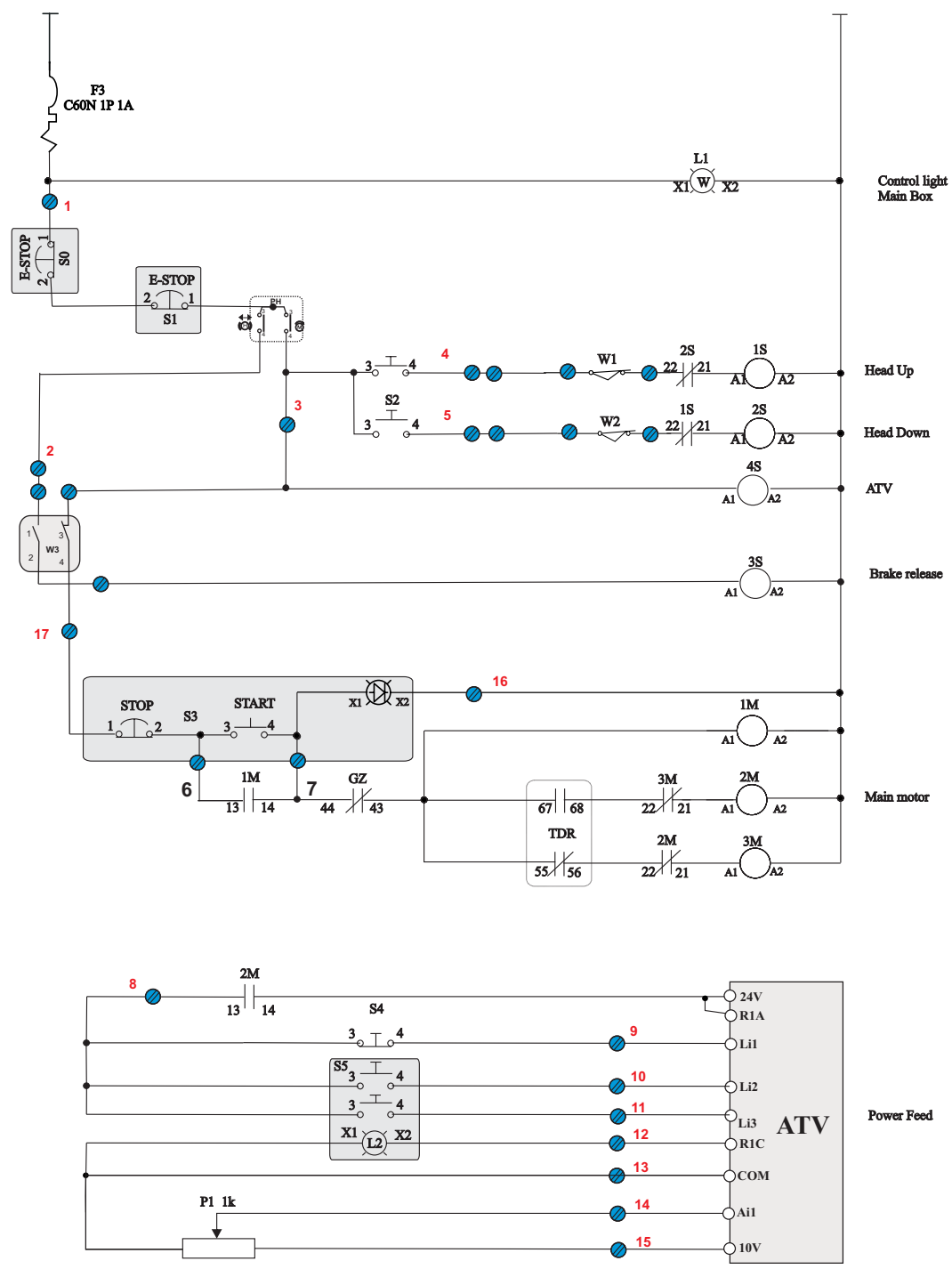

FIG. 5-2

5.6 Electrical Component List, HR115

Symbol	Wood-Mizer Part No.	Description	Manufacturer
Q	089801	Switch, ABB OT16E3	ABB
GZ1	090561	Motor Switch, GZ1 M20	SCHNEIDER ELECTRIC
GZ2	090561	Motor Switch, GZ1 M20	SCHNEIDER ELECTRIC
1M, 2M, 3M	084305	Contactora, LC1 D09 B7	SCHNEIDER ELECTRIC
M1+H	090993	Motor, Sg132S-2B-HM 380V	INDUKTA
F1	094799	Circuit Breaker, C60N 3P 4A	SCHNEIDER ELECTRIC
F2	093905	Circuit Breaker, C60N 2P 1A	SCHNEIDER ELECTRIC
F3	084454	Circuit Breaker, C60N 1P 1A	SCHNEIDER ELECTRIC
1S, 2S, 3S, 4S	084309	Contactora, LC1 K601 B7	SCHNEIDER ELECTRIC
M2	093860	Motor, SKh71X-4C2/HPS0/3PTC Up/Down	BESEL
M3	094897	Motor, SKH71X-6C1	BESEL
ATV	503468	Controller, ATV312H037N4	SCHNEIDER ELECTRIC
TR	094487	Transformer, SU78A-230400/24	NORATEL
L1	090448	Control Light, M22 White	MOELLER
S0, S1	094726	Emergency Stop Button, M22-PV/KC02/IY	MOELLER
S2	090917	Switch, M22-DD-S-X7/X7	MOELLER
W1, W2	100910	Limit Switch, GLCB01C	HONEYWELL
W3	094232	Safety Switch, AZ17-11ZRK	SCHMERSAL
S3	090452	START-STOP Switch, M22	MOELLER
TDR	084037	Relay, LADS2 Time	SCHNEIDER ELECTRIC
S4	090926	STOP Switch, M22	MOELLER
S5	091359	Switch, M22 WRLK3-G	MOELLER
PH	095001	Key Switch, M22-WRS3	MOELLER
P1	093749	Potentiometer, 1k	MOELLER

5.7 Dust Extractor Specifications



CAUTION! Always turn on the dust extractor before starting the machine.

See Table 5-7. Specifications of the dust extractors used on the resaw are listed below.

Airflow	1200 m ³ /h
Inlet diameter	150 mm
Motor power	1,5 kW
Number of sacks	1 pcs
Sack capacity	0.25 m ³
Weight	110 kg
Recommended conveying air velocity in the duct	20 m/s

TABLE 5-7



IMPORTANT! The dust extractor hoses must be grounded or made with materials not accumulating electrostatic charge.