

Wood-Mizer[®] Sawmill

Parts Manual

LT30AHD Super
LT40AHD Super

rev. B5.00
rev. B5.00



Safety is our #1 concern! Read and understand all safety information and instructions before operating, setting up or maintaining this machine.

November 1998

Form #921

Table of Contents

Section-Page

SECTION 1	GENERAL INFORMATION	1-1
1.1	How To Use The Parts List	1-1
1.2	Sample Assembly	1-1
SECTION 2	BLADE GUIDE ROLLERS & ARM	2-1
2.1	Blade Guide Assembly, Idle Side.....	2-1
2.2	Blade Guide Assembly, Drive Side.....	2-3
2.3	Blade Guide Arm & Rollers.....	2-5
2.4	Blade Guide Arm Drive Assembly.....	2-6
SECTION 3	BLADE WHEELS & TENSIONER	3-1
3.1	Blade Drive Assembly, LT30AHD/LT40AHD Super	3-1
3.2	Idle Blade Wheel Assembly	3-3
3.3	Hydraulic Blade Tensioner Assembly.....	3-4
SECTION 4	SAW HEAD	4-1
4.1	Middle Throat Screw.....	4-1
4.2	Water Lube Solenoid Valve	4-2
4.3	Board Return Assembly	4-3
4.4	Water Lube Assembly	4-5
4.5	Saw Head Decals	4-7
4.6	Blade Housing Covers.....	4-9
4.7	Drive Belt Covers	4-11
4.8	Sawdust Chute.....	4-13
SECTION 5	CONTROL & BATTERY BOXES	5-1
5.1	Control Assembly, LT30AHD/LT40AHD Super	5-1
5.2	Drum Switches	5-3
5.3	Circuit Breakers.....	5-4
5.4	Front Panel Assembly & Harnesses	5-5
SECTION 6	UP/DOWN SYSTEM	6-1
6.1	Saw Head V-Brace Mount.....	6-1
6.2	Blade Height Scale	6-2
6.3	Up/Down Chain & Sprockets.....	6-4
6.4	Up/Down Motor Assembly, LT30AHD/LT40AHD Super.....	6-6
6.5	Up/Down Drive Assembly	6-7

Table of Contents

Section-Page

SECTION 7	POWER FEED & TRACK ROLLERS	7-1
7.1	Upper Track Rollers And Wipers.....	7-1
7.2	Power Feed Assembly, LT30AHD/LT40AHD Super.....	7-2
7.3	Feed Chain/Stop	7-4
7.4	Lower Track Rollers	7-6
SECTION 8	BED FRAME ASSEMBLY	8-1
8.1	Bed Rail Assembly, Front And Rear	8-1
8.2	Bed Rail Assembly, Front Middle	8-3
8.3	Bed Rail Assembly, Rear Middle	8-4
8.4	Leg, Stationary	8-6
8.5	Board Return Table Assembly	8-8
8.6	Pivot Bed Rail Assembly.....	8-10
8.7	Log Side Support Assembly (Manual)	8-12
8.8	Tie Down Chain Assembly	8-14
8.9	Saw Head Rest Pin Assembly	8-15
8.10	Bed Frame Decals	8-16
SECTION 9	HYDRAULIC SYSTEM	9-1
9.1	Hydraulic Hoses, LT30HD/40HD Super	9-1
9.2	Hydraulic Control Box, LT30AHD/LT40AHD Super	9-2
9.3	Hydraulic Power Supply Strip.....	9-4
9.4	Hydraulic Log Loader	9-6
9.5	Hydraulic Log Turner	9-8
9.6	Hydraulic Log Side Supports	9-10
9.7	Hydraulic Log Clamp.....	9-12
9.8	Hydraulic Toe Board.....	9-14

SECTION 1 GENERAL INFORMATION

1.1 How To Use The Parts List

- Use the index above to locate the assembly that contains the part you need.
- Go to the appropriate section and locate the part in the illustration.
- Use the number pointing to the part to locate the correct part number and description in the table.
- Parts shown indented under another part are included with that part.
- Parts marked with a diamond (◆) are only available in the assembly listed above the part.

See the sample table below. Sample Part #A01111 includes part F02222-2 and subassembly A03333. Subassembly A03333 includes part S04444-4 and subassembly K05555. The diamond (◆) indicates that S04444-4 is not available except in subassembly A03333. Subassembly K05555 includes parts M06666 and F07777-77. The diamond (◆) indicates M06666 is not available except in subassembly K05555.

1.2 Sample Assembly				
REF	DESCRIPTION (◆ Indicates Parts Available in Assemblies Only)	PART #	QTY.	
	Sample Assembly, Complete (Includes All Indented Parts Below)	A01111	1	
1	Sample Part	F02222-22	1	
	Sample Subassembly (Includes All Indented Parts Below)	A03333	1	
2	Sample Part (◆ Indicates Part Is Only Available With A03333)	S04444-4	1	◆
	Sample Subassembly (Includes All Indented Parts Below)	K05555	1	
3	Sample Part (◆ Indicates Part Is Only Available With K05555)	M06666	2	◆
4	Sample Part	F07777-77	1	

To Order Parts:

- From Europe call our European Headquarters and Manufacturing Facility in Kolo, Poland at **+48-63-2610233**. From the continental U.S., call our toll-free Parts hotline at **1-800-448-7881**. Have your customer number, vehicle identification number, and part numbers ready when you call.
- From other international locations, contact the Wood-Mizer distributor in your area for parts.

SECTION 2 BLADE GUIDE ROLLERS & ARM

2.1 Blade Guide Assembly, Idle Side

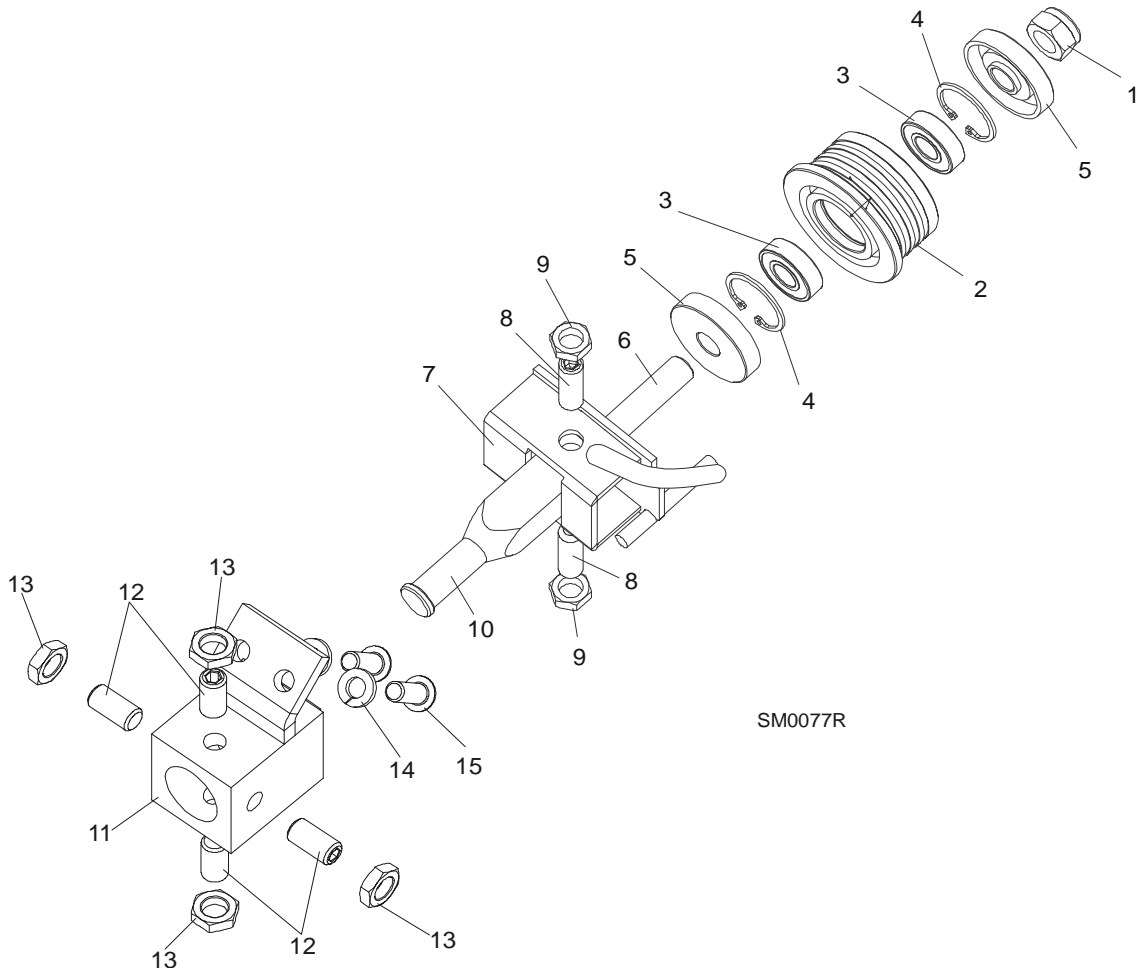

SM0077R

REF	DESCRIPTION (◆ Indicates Parts Available In Assemblies Only)	PART #	QTY.
	BLADE GUIDE ASSEMBLY, COMPLETE IDLE SIDE	A08197	1
	Roller, Blade Guide With Bearings	087887	1
	Roller, Blade Guide With Bearings Extended (for optional use with 1 1/2" blades)	087888 ¹	1
1	Nut, M12-8 Fe/Zn5 Jam Nylon Lock	F81034-2	1
2	Roller, Flanged Blade Guide	087889	1
	Roller, Blade Guide Extended (for optional use with 1 1/2" blades)	087890 ¹	1
3	Bearing, R8-2RS Blade Guide	087893	2
4	Ring, 1 1/8" Interior Retaining	F81090-9	2
5	Spacer, Blade Guide	087891	2
6	Bolt, Blade Guide Mounting	087763	1
7	Bracket, Blade Guide Idle Side With Water Tube	W08495	1
	Screw Kit, Blade Guide Adjustment w/Nuts (For two blade guide assemblies)	K09942	1
8	Screw, 3/8-24 X 1 1/4" Stainless Steel Socket Head Flat Point	F05007-96	4

2**Blade Guide Rollers & Arm***Blade Guide Assembly, Idle Side*

9	Nut, 3/8-24 Jam	F05010-22	4	
10	Shaft, Blade Guide Adjustment	S08196	1	
11	TUBE, BLADE GUIDE MOUNT (See Section 2.3 Blade Guide Arm & Rollers)	088292-1	1	
12	SCREW, M10X1X20 DIN913 STAINLESS STEEL SOCKET HEAD FLAT POINT	F81015-1	4	
13	NUT, M10X1 DIN439 JAM	F81033-7	4	
14	WASHER, 8,2 SPLIT LOCK ZINC	F81054-4	2	
15	SCREW, 5/16-18x3/4 Socket Button Head Black Oxide	F05006-7	2	

¹ Recommended for Super sawmills only.

2.2 Blade Guide Assembly, Drive Side

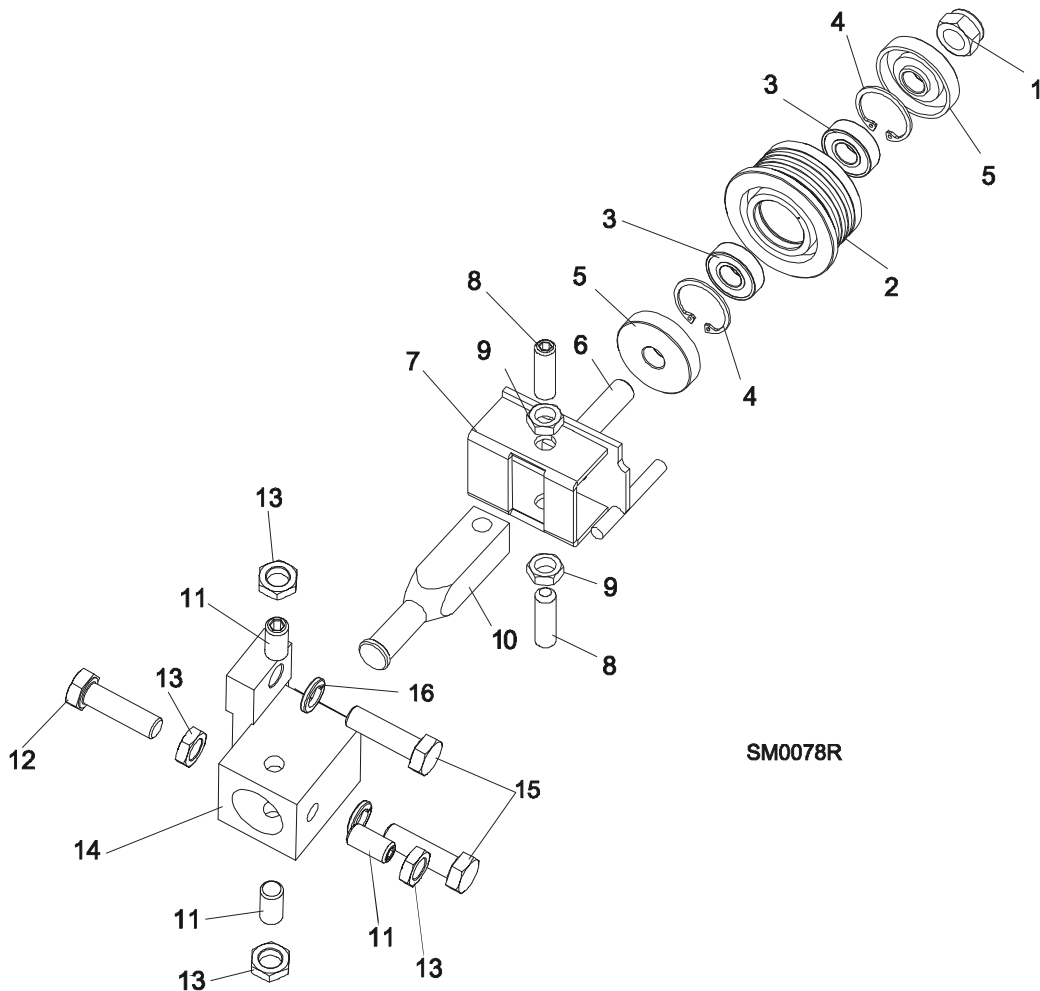

REF	DESCRIPTION (◆ Indicates Parts Available In Assemblies Only)	PART #	QTY.
	BLADE GUIDE ASSEMBLY, COMPLETE DRIVE SIDE	A08191	1
	Roller, Blade Guide With Bearings	087887	1
	Roller, Blade Guide With Bearings Extended (for optional use with 1 1/2" blades)	087888 ¹	1
1	Nut, M12-8 Fe/Zn5 Jam Nylon Lock	F81034-2	1
2	Roller, Flanged Blade Guide	087889	1
	Roller, Blade Guide Extended (for optional use with 1 1/2" blades)	087890 ¹	1
3	Bearing, R8-2RS Blade Guide	087893	2
4	Ring, 1 1/8" Interior Retaining	F81090-9	2
5	Spacer, Blade Guide	087891	2
6	Bolt, Blade Guide Mounting	087763	1
7	Bracket, Blade Guide Drive Side	W08482	1
	Screw Kit, Blade Guide Adjustment w/Nuts (For two blade guide assemblies)	K09942	1

2

Blade Guide Rollers & Arm

Blade Guide Assembly, Drive Side

8	Screw, 3/8-24 X 1 1/4" Stainless Steel Socket Head Flat Point	F05007-96	4	
9	Nut, 3/8-24 Jam	F05010-22	4	
10	Shaft, Blade Guide Adjustment	S08196	1	
11	SCREW, M10X1X20 DIN913 STAINLESS STEEL SOCKET HEAD FLAT POINT SET	F81015-1	3	
12	BOLT, M10X1X25 DIN 933 STAINLESS STEEL HEX HEAD	F81003-28	1	
13	NUT, M10X1 DIN439 JAM	F81033-7	4	
14	TUBE, BLADE GUIDE MOUNT (Bolted to the Saw Frame)	087744	1	
15	BOLT, M10X35-8.8 HEX HEAD FULL THREAD ZINC	F81003-17	2	
16	WASHER, 10.2 SPLIT LOCK ZINC	F81055-2	2	

¹ Recommended for Super sawmills only.

2.3 Blade Guide Arm & Rollers

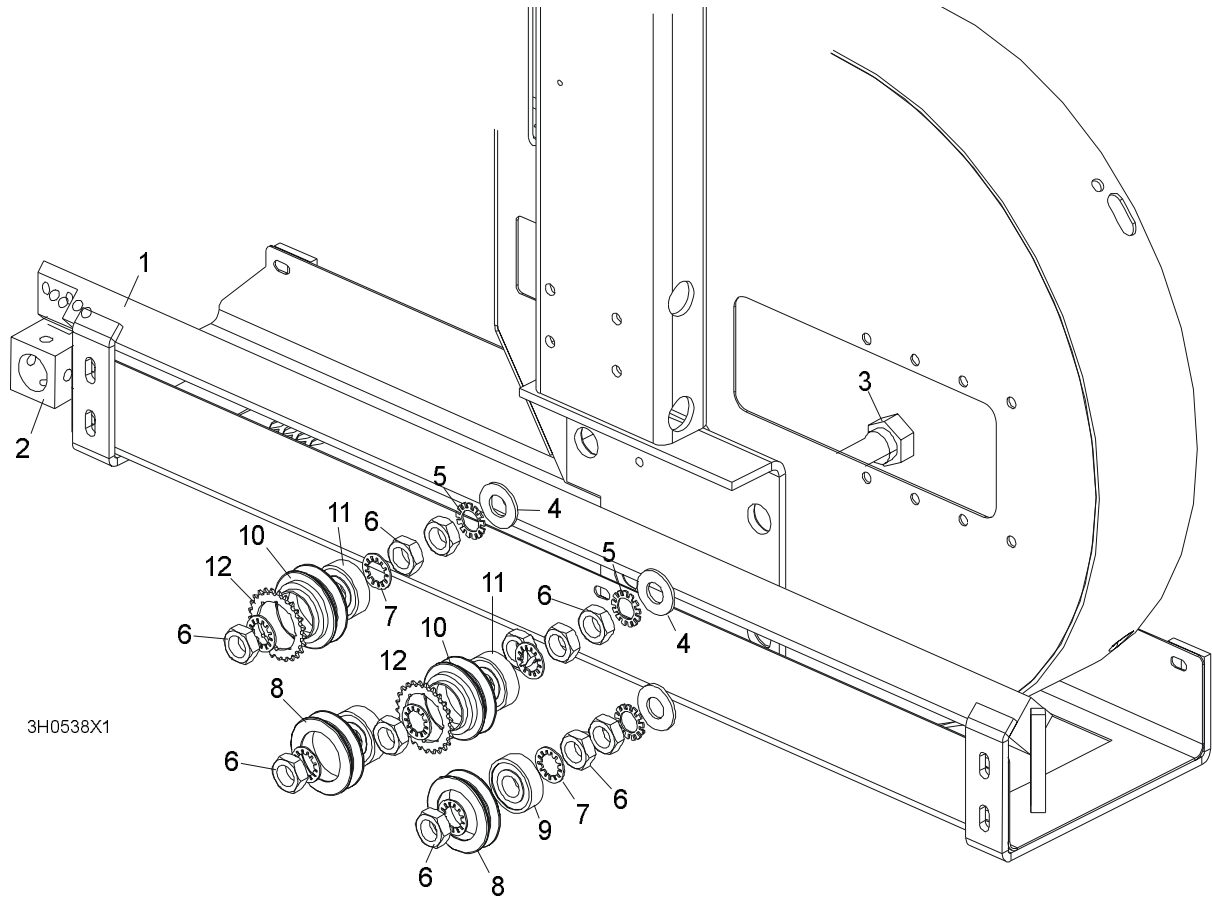

REF	DESCRIPTION (◆ Indicates Parts Available In Assemblies Only)	PART #	QTY.	
1	BLADE GUIDE ARM WELDMENT	087018-1	1	
2	Tube, Blade Guide Mount (G.S. - Bolted to Blade Guide Arm)	W10426	1	
3	BOLT, BLADE GUIDE ARM ROLLER CAM	086508-1	4	
4	WASHER, 17 FLAT	F81058-1	4	
5	WASHER, 5/8" EXTERNAL STAR	F05011-26	4	
6	NUT, 5/8-18 HEX JAM	F05010-11	12	
7	WASHER, 5/8" INTERNAL STAR	F05011-25	8	
	ROLLER ASSEMBLY, BLADE GUIDE ARM WITH BEARING	A09059	2	
8	Roller, Blade Guide Arm V-Groove	S07989-W	1	◆
9	Bearing, 6203-2NSL 5/8" I.D.	P06030-1	1	
	ROLLER ASSEMBLY, BLADE GUIDE ARM WITH BEARING AND SPROCKET	A09932	2	
10	Roller, Blade Guide Arm Drive	S09930-W	1	◆
11	Bearing, 6203-2NSL 5/8" I.D.	P06030-1	1	
12	Sprocket, #25 26-Tooth	015939	1	◆

2.4 Blade Guide Arm Drive Assembly

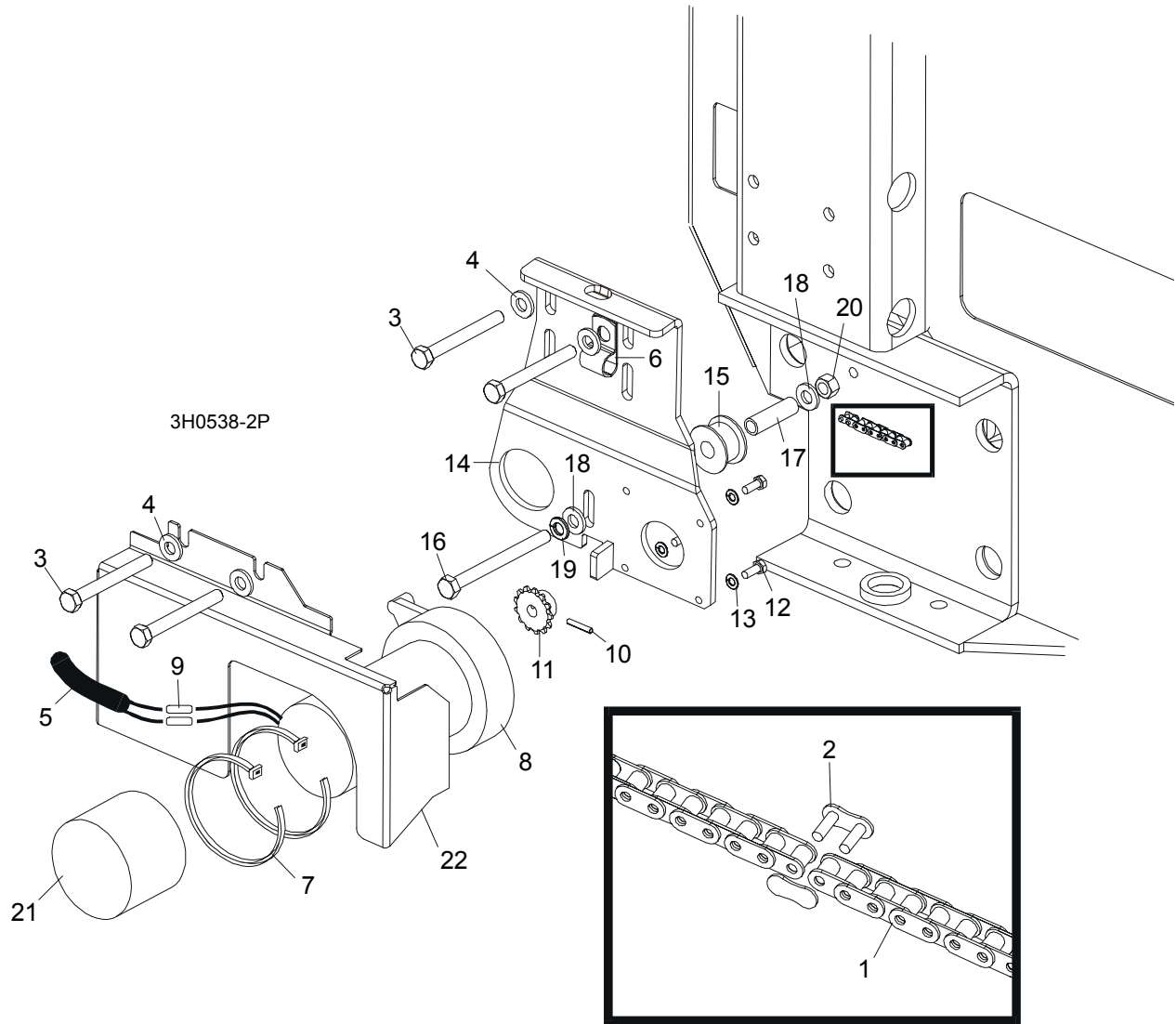

REF	DESCRIPTION (◆ Indicates Parts Available In Assemblies Only)	PART #	QTY.
1	CHAIN, #25 X 20 1/4"	P09984	1
2	LINK, #25 MASTER	P09983	1
3	BOLT, 5/16-18 X 2 3/4" HEX HEAD GRADE 5	F05006-28	4
4	WASHER, 8.4 FLAT	F81054-1	4
5	TUBE, 3/8" X 1/2" NEOPRENE	R01897	0,75 m
6	CLAMP, 1/2" COATED EMT	P07584	2
7	WRAP, 1/4" X 6" TIE	F05089-1	2
	DRIVE ASSEMBLY, BLADE GUIDE ARM	091005	1
	Motor Assembly, Blade Guide Arm Replacement	A10365	1
8	Motor, Blade Guide Arm 53:1 Gear	P09698-1	1
	Housing, Klauber Motor End	P12756	1

	Gear Kit, Klauber Motor Replacement	P12569	1	
	Brush Kit, Gear Motor Replacement	P12800	1	
	Shaft Kit, Klauber Gear Motor Replacement	009695	1	
9	Connector, 14 Gauge Butt	F04875-1	2	
10	Pin, 1/8" X 3/4" Roll	F05012-6	1	
11	Sprocket, Gear Motor #25 14-Tooth	P09970	1	
12	Screw, #10-32 x 1/2" Hex Head	F05004-60	4	
13	Washer, 4.1 Split Lock	F81051-4	4	
	Instruction Sheet, Blade Guide Arm Motor	A10353-296	1	
14	Bracket, Blade Guide Arm Motor Mount	087994-1	1	
15	Roller, Blade Guide Arm Chain Idler	S09999	1	
16	Bolt, 5/16-18 X 3 1/2" Hex Head Full Thread	F05006-3	1	
17	Spacer, 5/16" I.D. X 1 1/2"	S09996	1	
18	Washer, 5/16" SAE Flat	F81054-1	2	
19	Washer, 8.4 Split Lock	F05011-13	1	
20	Nut, 8.2 Hex Lock	F81054-4	1	
21	Boot, Gear Motor Weather	023720	1	
22	COVER, BLADE GUIDE ARM MOTOR	S11617	1	
	GUARD, BLADE GUIDE ARM (G.S. ONLY)	S12029	1	

SECTION 3 BLADE WHEELS & TENSIONER

3.1 Blade Drive Assembly, LT30AHD/LT40AHD Super

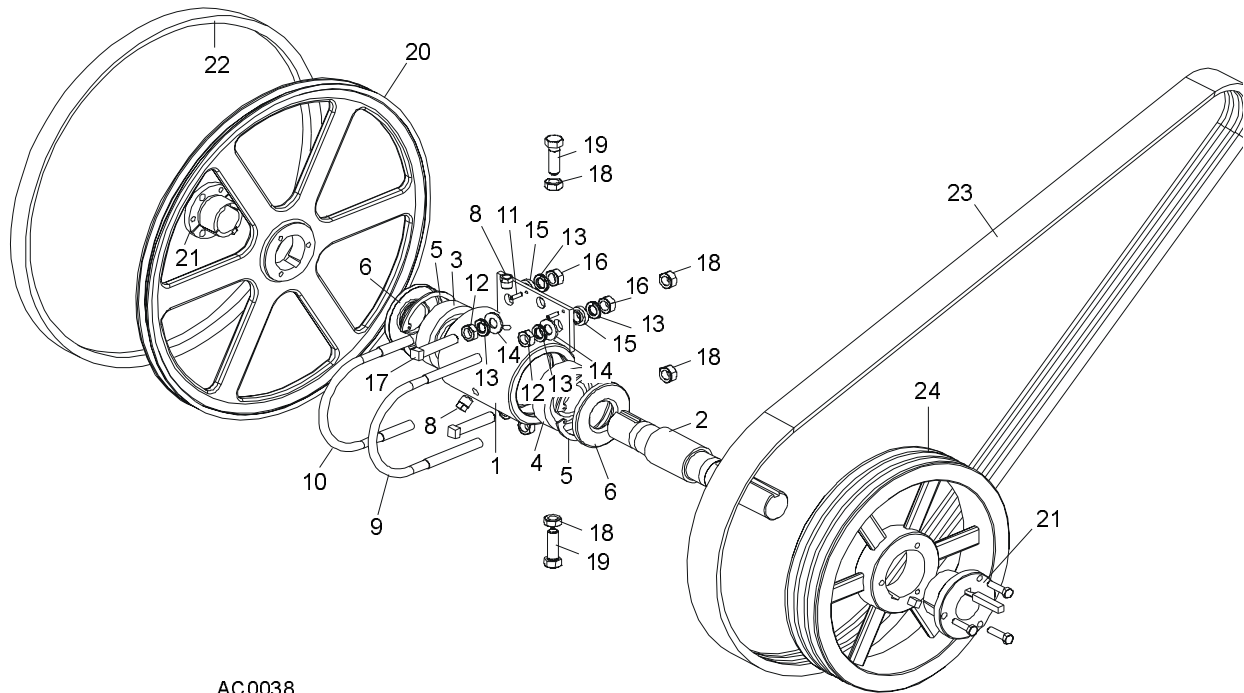

AC0038

REF	DESCRIPTION (◆ Indicates Parts Available In Assemblies Only)	PART #	QTY.	
	BEARING ASSEMBLY, BLADE WHEEL DRIVE	014561	1	
	Bearing Assembly, Drive	086291	1	
1	Housing, Blade Wheel Drive Bearing	W10201	1	◆
2	Shaft, Blade Wheel Drive	086292	1	◆
3	Bearing, Blade Wheel Drive NJ308	085939	1	
4	Bearing, Blade Wheel Drive #6308	085940	1	
5	Ring, 90mm Interior Retaining #117	F04254-17	2	
6	Seal, Drive Bearing #CR15890	P10206	2	
7	Plug, 1/4" NPT Square Head	P05498	1	
8	Plug, 1/4" NPT Vented	P12868	1	
9	Bolt, 1/2-13 Long U	S10207-1P	1	
10	Bolt, 1/2-13 Short U	S10207-2P	1	
11	Pin, 3/16" X 5/8" Roll	F05012-22	2	
12	Nut, 1/2-20 Hex Jam	F05010-16	4	
13	Washer, 12.2 Split Lock	F81056-2	8	
14	Washer, 13 SAE Flat	F81056-1	4	

3

Blade Wheels & Tensioner

Blade Drive Assembly, LT30AHD/LT40AHD Super

15	Spacer, .510" x .937" x .34"	S04253	4	
16	Nut, 1/2-13 Hex	F05010-35	4	
17	Screw, 1/2-20 x 2 1/2" Square Head Full Thread Set	F05008-110	2	
18	Nut, M12-8 Hex Nylon Lock	F81034-2	4	
19	Bolt, 1/2-20 x 1 1/2" Hex Head Grade 5	F05008-53	2	
	Decal, Bearing End-Play	S12750	1	
	Instruction Sheet, Bearing Retrofit	K10200-275	1	
	WHEEL KIT, DRIVE SIDE BLADE	014562	1	
20	Wheel, Drive Side Blade	016284	1	
21	Bushing, Modified 1 9/16" P1	087214	1	
	Instruction Sheet, Drive Side Blade Wheel Replacement	K12987-488	1	
22	BELT, BLADE WHEEL B57	P04185	1	
23	BELT, 3BX72 DRIVE (EA20, EA25)	014249	1	
24	PULLEY, 3B124 SK SPECIAL (EA20, EA25)	087203-1	1	

3.2 Idle Blade Wheel Assembly

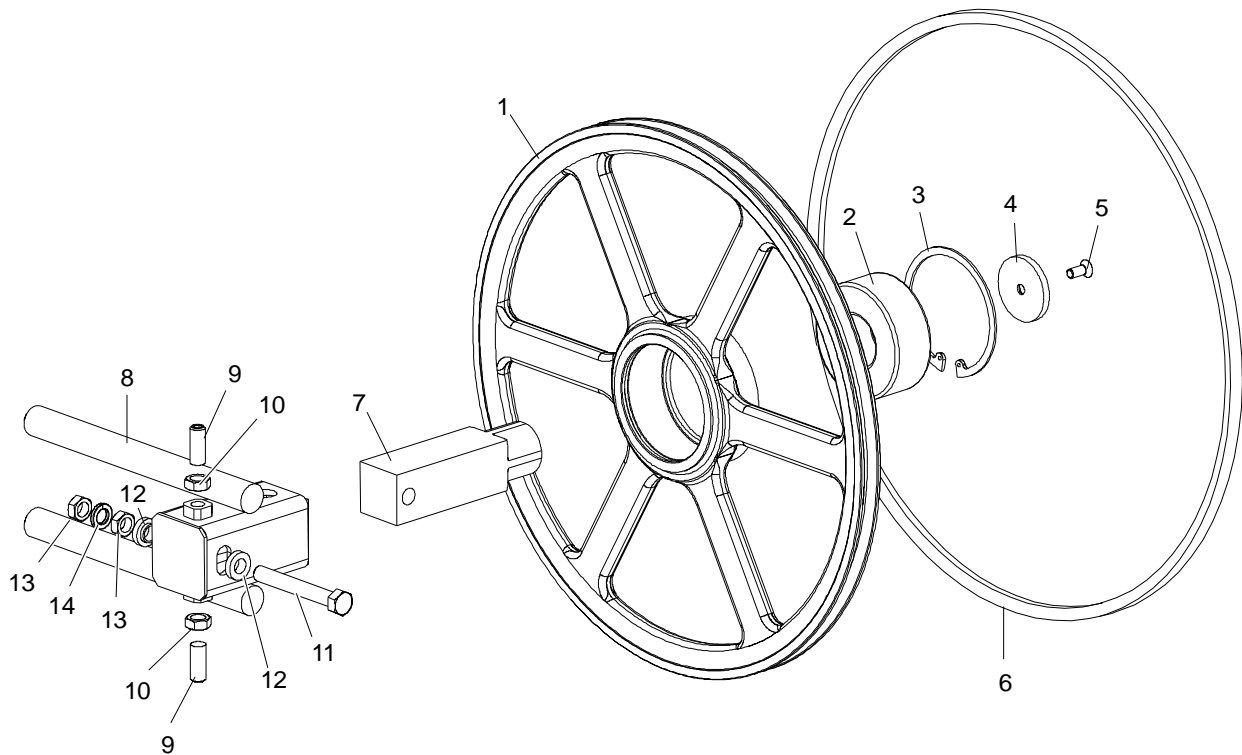

SM0241

REF	DESCRIPTION (◆ Indicates Parts Available In Assemblies Only)	PART #	QTY.	
	WHEEL ASSEMBLY, IDLE SIDE BLADE	016120	1	
1	Wheel, Idle Side Blade	016013	1	◆
2	Bearing, Idle Side Blade Wheel #5309-2RS, C3, SRI-2 Grease	086428	1	
3	Ring, 100mm Internal Retaining Beveled	F04254-28	1	
4	RETAINER, 2 3/16 X 1/4"	016397	1	
5	BOLT, 5/16-18 X 3/4" FLAT HEAD SOCKET	F05006-95	1	
6	BELT, BLADE WHEEL B57	P04185	1	
7	SHAFT, IDLE BLADE WHEEL	016398	1	
8	HOUSING, IDLE BLADE WHEEL SHAFT	016103	1	
9	SCREW, 1/2-20 X 1 1/4" FLAT POINT SET	F05008-109	2	
10	NUT, 1/2-20 HEX JAM	F05010-16	2	
11	BOLT, 1/2-20 X 3 3/4" HEX HEAD FULL THREAD GRADE 2	F05008-111	1	
12	SPACER, 1/2" I.D. FLANGED	086769-1	2	
13	NUT, 1/2-20 HEX JAM	F05010-16	2	
14	WASHER, 12.2 SPLIT LOCK	F81056-2	1	

3 Blade Wheels & Tensioner

Hydraulic Blade Tensioner Assembly

3.3 Hydraulic Blade Tensioner Assembly

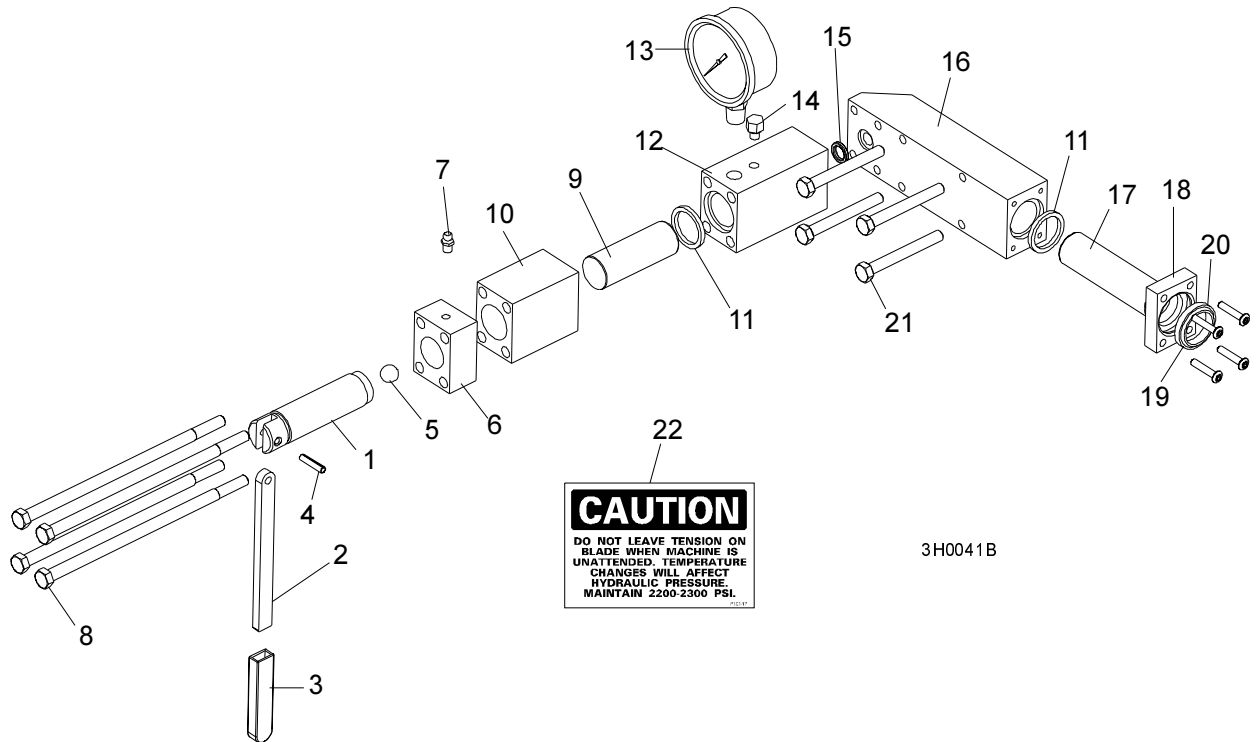

REF	DESCRIPTION (◆ Indicates Parts Available In Assemblies Only)	PART #	QTY.
	HYDRAULIC BLADE TENSIONER ASSEMBLY	A10054	1
	Handle Assembly, Hydraulic Blade Tensioner Screw	A12294	1
1	Screw, Hydraulic Blade Tensioner	S10056	1
2	Handle, Hydraulic Tensioner Screw	S08174	1
3	Sleeve, Plastic Handle	P08072	1
4	Pin, 3/16" x 7/8" Roll	F05012-19	1
5	Ball, 1/2" Steel	P02720	1
6	Block, Threaded Tensioner End	S10062	1
7	Fitting, 1/4-28 Grease	P05060	1
	Instruction Sheet, Tensioner Screw	A12294-518	1
8	Bolt, 5/16-18 X 7 1/2" Hex Head Grade 5	F05006-43	4
9	Piston, Hydraulic Tensioner Front 2 3/4" Long	S10060	1
10	Block, Piston Guide	S10061	1
11	Seal, 1" Diameter	P10051	2
12	Block, Hydraulic Tensioner Gauge Mounting	S10140	1
13	Gauge, 3000 PSI	090552	1
14	Plug, Hydraulic Tensioner Fill	P10065	1
15	Ring, 5/8" X 3/32" Square "O"	P10377	1
16	Block, Rear Tensioner Piston	S10142	1

Blade Wheels & Tensioner
Hydraulic Blade Tensioner Assembly

3

17	Piston, Hydraulic Tensioner Rear 3 5/8" Long	S10059	1	
18	Block, Rear Piston End	S10089	1	
19	Wiper, 1" Diameter	P10053	1	
20	Bolt, #10-24 X 1" Socket Button Head	F05004-43	4	
21	Bolt, 5/16-18 X 2 3/4" Hex Head Grade 5	F05006-28	4	
22	Decal, Hydraulic Tension Caution	P10147	1	
	Instruction Sheet, Hydraulic Tensioner Installation	A10136-272	1	

SECTION 4 SAW HEAD

4.1 Middle Throat Screw

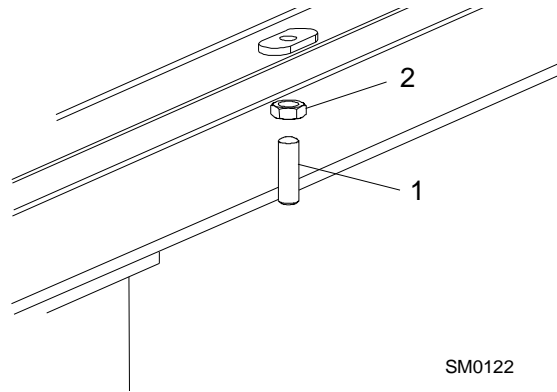

REF	DESCRIPTION (◆ Indicates Parts Available In Assemblies Only)	PART #	QTY.	
1	SCREW, 3/8-16 X 1 1/4" OVAL POINT SOCKET SET	F05007-18	1	
2	NUT, 3/8-16 HEX JAM	F05010-29	1	

4 Saw Head

Water Lube Solenoid Valve

4.2 Water Lube Solenoid Valve

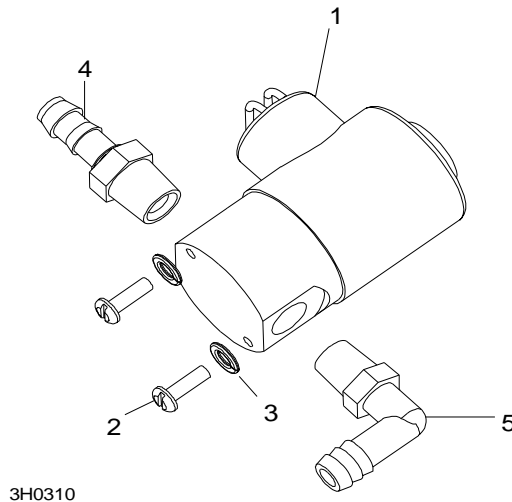

REF	DESCRIPTION (◆ Indicates Parts Available In Assemblies Only)	PART #	QTY.
1	VALVE, WATER LUBE SOLENOID	016140	1
2	SCREW, 4MM X 12 CROSS SLOT ROUND HEAD	F05004-74	2
3	WASHER, 4MM SPLIT LOCK	F05011-57	2
4	FITTING, 1/4" MALE NPT 3/8" HOSE BARB	P04682	1
5	FITTING, 1/4" MALE NPT 3/8" HOSE BARB ELBOW	P04730	1

4.3 Board Return Assembly

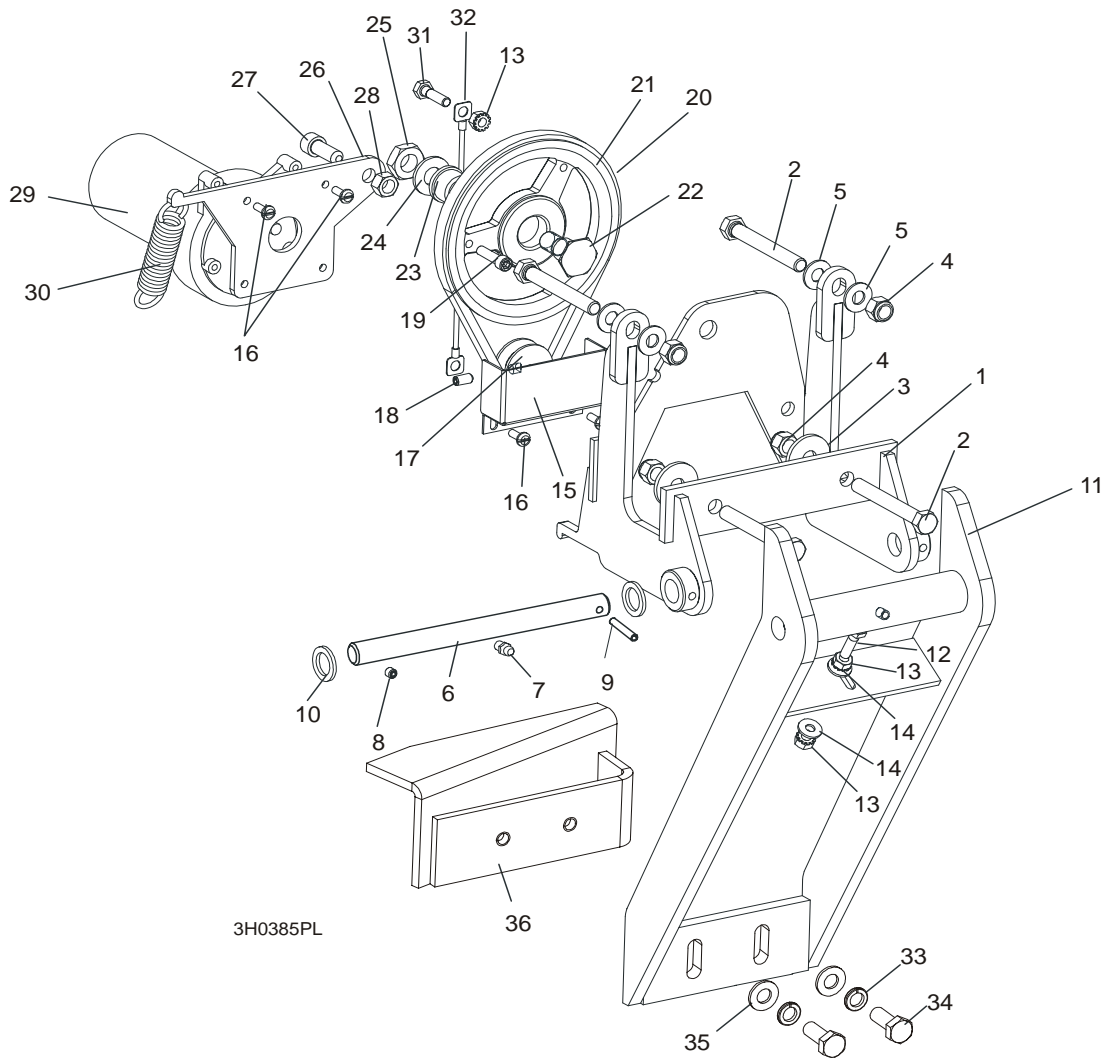

REF	DESCRIPTION (◆ Indicates Parts Available In Assemblies Only)	PART #	QTY.
	RETURN ASSEMBLY, BOARD	087839-1	1
1	Mount Weldment, Board Return	087788-1	1
2	Bolt, 3/8-16 x 3" Full Thread Hex Head	F05007-1	4
3	Washer, 1/8" x 1 1/4"	015336	2
4	Nut, 3/8-16 Hex Nylon Lock	F05010-10	4
5	Washer, 10.5 Flat	F81055-1	4
6	Pin Kit, Board Return Replacement Pivot	087837	1
7	Fitting, M6 Grease	086280	1
8	Screw, M6 X 8 Black Oxide Socket Head Set Cup Point	F81013-1	1
9	Pin, 5 X 30 Roll	F81044-21	1
10	Washer, 5/8" x 15/16" x .094 Nylon	F05011-19	2

4

Saw Head*Board Return Assembly*

11	Arm Weldment, Board Return	087838-1	1	
12	Screw, 1/4-20 x 3/4" Full Thread Hex Head Cap	F05005-101	1	
13	Nut, 1/4-20 Self Locking	F05010-9	3	
14	Washer, 7.4 Flat	F81056-11	2	
15	Guard, Board Return Belt	015007	1	
16	Screw, 10-32 x 1/2" Hex Head Machine	F05004-55	4	
17	Sheave, 1.42 x .32	015074	1	
18	Screw, 1/4-20 Socket Head Set Cup Point Nylon	F05005-55	1	
19	Screw, 1/4-20 x 1" Socket Head Cap	F05005-89	1	
20	Belt, 3L190	015477	1	
21	Sheave, OK50 x 1/2" Modified	015224	1	
22	Bolt, Idler Pulley Pivot	015221	1	
23	Bushing, 5/8" x 7/8" x 1/2" Bronze	P05135	1	
24	Washer, 13 Flat	F81056-1	1	
25	Nut, 1/2-20 Jam Nylon Lock	F05010-79	1	
26	Plate, Motor Pivot	087871	1	
27	Screw, M10 x 25-8.8 Black Oxide Socket Head Cap	F81003-32	1	
28	Nut, 3/8-16 Self Locking	F05010-25	1	
29	Motor, 53:1 ASA Gear	P09698-1	1	
30	Spring, 3/4" x 2 7/8" x 12 Gauge	015479	1	
31	Bolt, 1/4-20 x 1" Hex Head Grade 5	F05005-101	1	
32	Cable, Board Return	016090	1	
33	Washer, 10.2 Split	F81055-2	2	
34	Bolt, 3/8-16 x 3/4" Hex Head	F81003-1	2	
35	Washer, 10.5 Flat	F81055-1	2	
36	Angle, Board Return	087835-1	1	

4.4 Water Lube Assembly

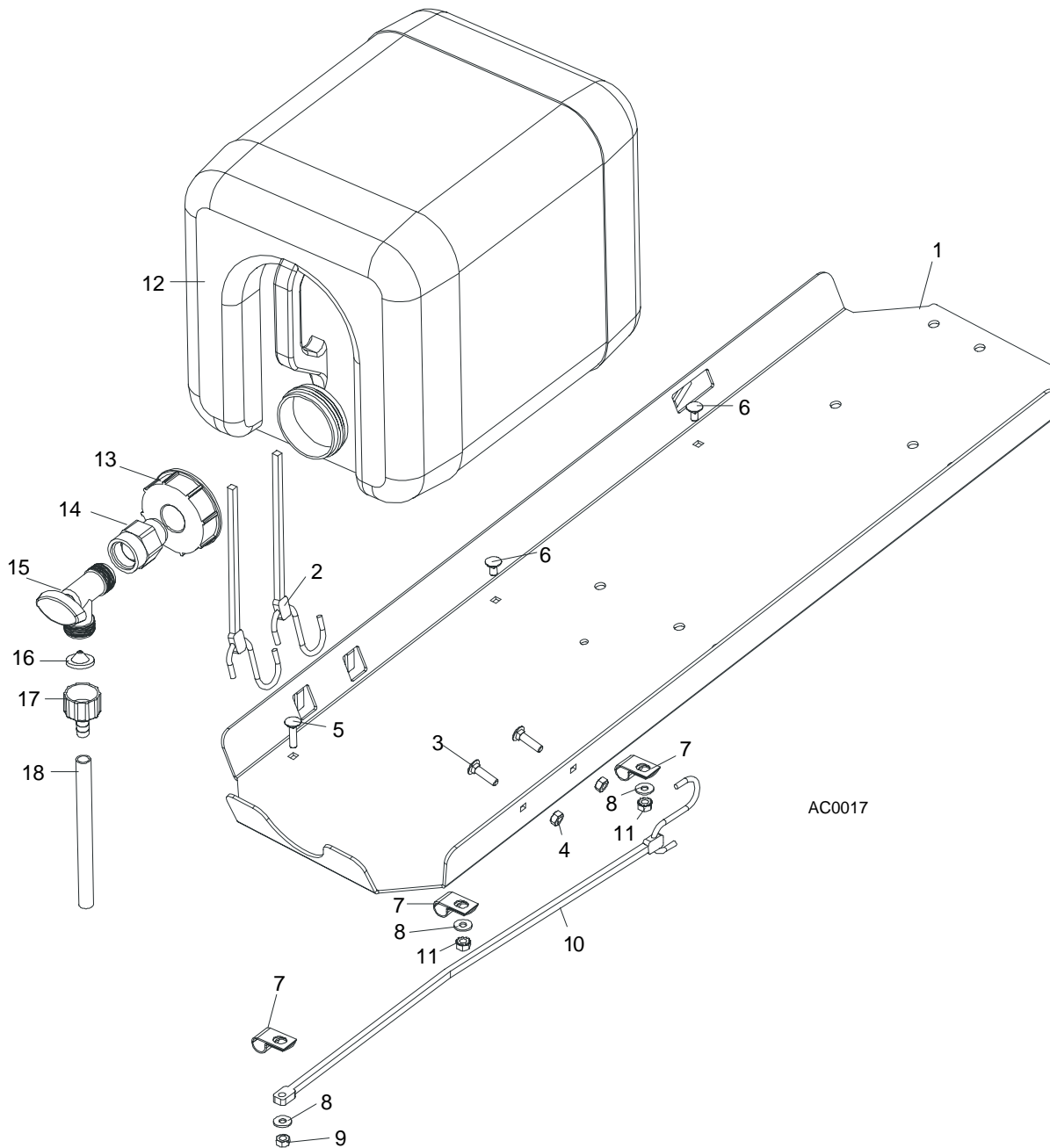

REF	DESCRIPTION (◆ Indicates Parts Available In Assemblies Only)	PART #	QTY.	
1	TRAY, ELECTRIC BOX/WATER BOTTLE	086528-1	1	◆
2	STRAP, 20" RUBBER	P11668	2	
3	BOLT, 1/4-20 X 1" CARRIAGE HEAD	F05005-34	4	
4	NUT, 1/4-20 HEX LOCK	F05010-21	4	
5	BOLT, 1/4-20 X 1" CARRIAGE HEAD	F05005-34	1	
6	BOLT, 1/4-20 X 1/2" CARRIAGE HEAD	F05005-33	2	
7	CLAMP, 1/2" EMT HOSE	P07584	3	

4

Saw Head*Water Lube Assembly*

8	WASHER, 7.4 FLAT	F81056-11	3	
9	NUT, 1/4-20 HEX LOCK	F05010-21	1	
10	STRAP, 15" RUBBER	P07461	1	
11	NUT, 1/4-20 SELF-LOCKING	F05010-9	2	
	BOTTLE ASSY, WATER LUBE	014642	1	
12	Bottle, 5-Gallon Water Lube	014637	1	
13	Cap, Water Lube Bottle Buttress Thread	014773	1	
14	FITTING, 3/4FPT X 3/4MPT	014636	1	
15	FITTING, WATER LUBE SHUTOFF VALVE	014100	1	
16	FILTER, WATER LUBE	016086 ¹	1	
17	FITTING, 5/8" NPT TO 3/8" HOSE BARB	014113	1	
18	TUBING, WATER LUBE 3/8" I.D.	R01885	2,1 m	

¹ Filter recommended for Super models to prevent debris from entering water lube solenoid valve.

4.5 Saw Head Decals

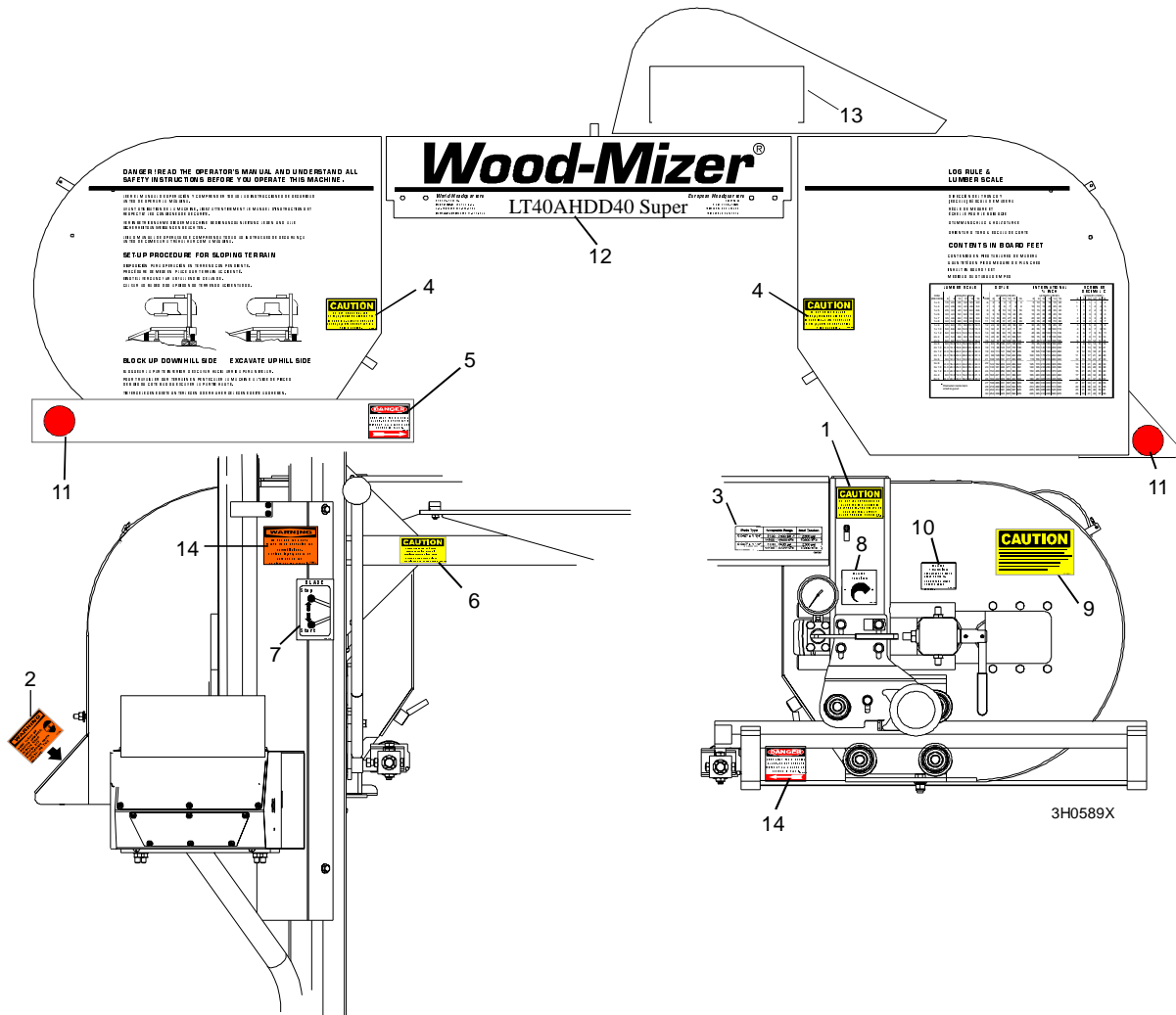

REF	DESCRIPTION (◆ Indicates Parts Available In Assemblies Only)	PART #	QTY.
1	DECAL, BLADE TENSION CAUTION	P10147	1
2	DECAL, SAWDUST CHUTE WARNING	P11754	1
3	DECAL, BLADE TENSION RANGES	085080	1
4	DECAL, BLADE COVERS CAUTION	S20039	2
5	DECAL, BLADE DANGER ARROW RIGHT	S11752	1
6	DECAL, UP/DOWN CAUTION	S11762	1
7	DECAL, BLADE START/STOP	P11779	1
8	DECAL, BLADE TENSION INFO	P11790	1
9	DECAL, SECURE THE SAW HEAD (PORTABLE SAWMILL ONLY)	S12581	1
10	DECAL, BLADE ALIGNMENT INFO	P11789	1
11	DECAL, RED REFLECTIVE 2" ROUND	P07452	2
12	DECAL, SAWMILL TYPE	N/A	
	Decal, LT30AHDE20S	086993	1
	Decal, LT30AHDE25S	086994	1

4**Saw Head***Saw Head Decals*

	Decal, LT40AHDE20S	086904	1	
	Decal, LT40AHDE25S	086910	1	
	Decal, SUPER	085088	1	
13	DECAL, WOOD-MIZER WHAT'S IN A NAME	S12528	1	
14	DECAL, BLADE DANGER ARROW LEFT	S11751	1	

4.6 Blade Housing Covers

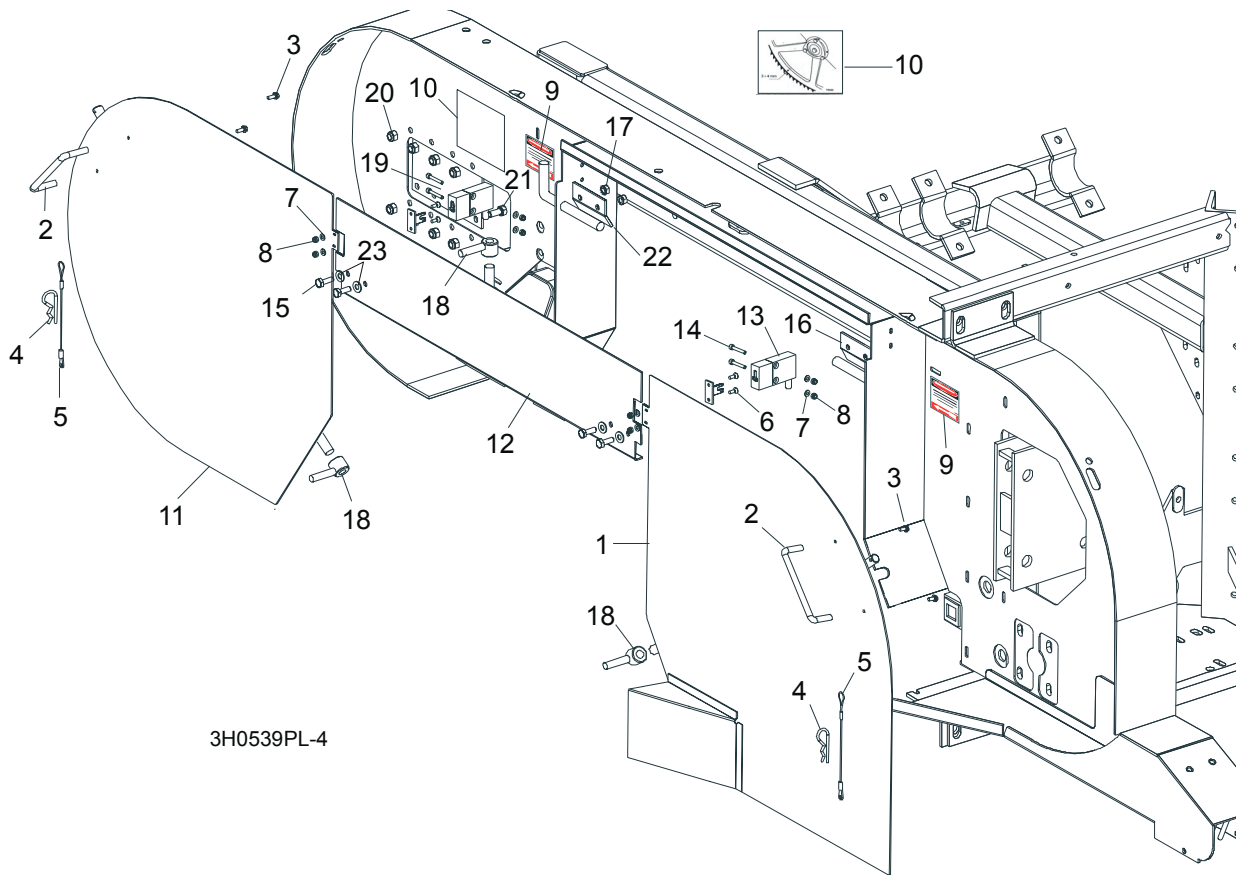

REF	DESCRIPTION (◆ Indicates Parts Available In Assemblies Only)	PART #	QTY.	
	COVER ASSEMBLY, DRIVE SIDE BLADE HOUSING WITH HANDLE	087165	1	
1	Cover Weldment, Drive Side Blade Housing	087159-1	1	◆
2	Handle, Blade Housing Cover	P08065	1	
3	Screw, #8-32 x 3/8"	F05015-8	2	
	Pin Assembly, Cover Retainer	A11881	1	
4	Pin, Safety Retainer	N/A	1	
5	Cable, 3/64" x 6" Lanyard	N/A	1	
6	Bolt, M4 x 12-5.8	F81011-41	2	
7	Washer, 4.3	F81051-2	4	
8	Nut, M4 Hex	F81029-1	2	
9	DECAL, BLADE DANGER W/ARROW	S11751	2	
10	DECAL, BLADE SETTING	P85066	1	
	COVER, IDLE SIDE BLADE HOUSING WITH HANDLE	086431	1	
11	Cover, Idle Side Blade Housing	086430-1	1	◆
2	Handle, Blade Housing Cover	P08065	1	
3	Screw, #8-32 X 3/8" Self-Tap	F05015-8	2	

4 Saw Head

Blade Housing Covers

	Pin Assembly, Cover Retainer	A11881	1	
4	Pin, Safety Retainer	N/A	1	
5	Cable, 3/64" x 6" Lanyard	N/A	1	
8	Screw, M4 x 12-5.8	F81011-41	4	
9	Washer, 4.3 Flat	F81051-2	4	
10	Nut, M4 Hex	F81029-1	2	
12	COVER, MIDDLE BLADE HOUSING	087326-1	1	
13	Switch, Emergency Stop	087650	2	
14	Bolt, M4 x 20-8.8 Socket Head	F81011-31	4	
15	BOLT, 1/4-20 X 3/4" HEX HEAD	F05005-1	4	
16	HINGE, MIDDLE BLADE HOUSING COVER	S07522	1	
17	NUT, 1/4-20 SELF-LOCKING HEX	F05010-9	4	
18	NUT, COVER TURN	086365-1	2	
19	PLATE, IDLE BLADE WHEEL GUARD	086230	1	
20	NUT, 5/16-18 HEX NYLON LOCK	F05010-58	6	
21	BOLT, 5/16-18 X 3/4" HEX HEAD GRADE 2	F05006-5	6	
22	HINGE, MIDDLE BLADE HOUSING COVER	085336-1	1	
23	WASHER 6.4 ZINC	F81053-1	4	

4.7 Drive Belt Covers

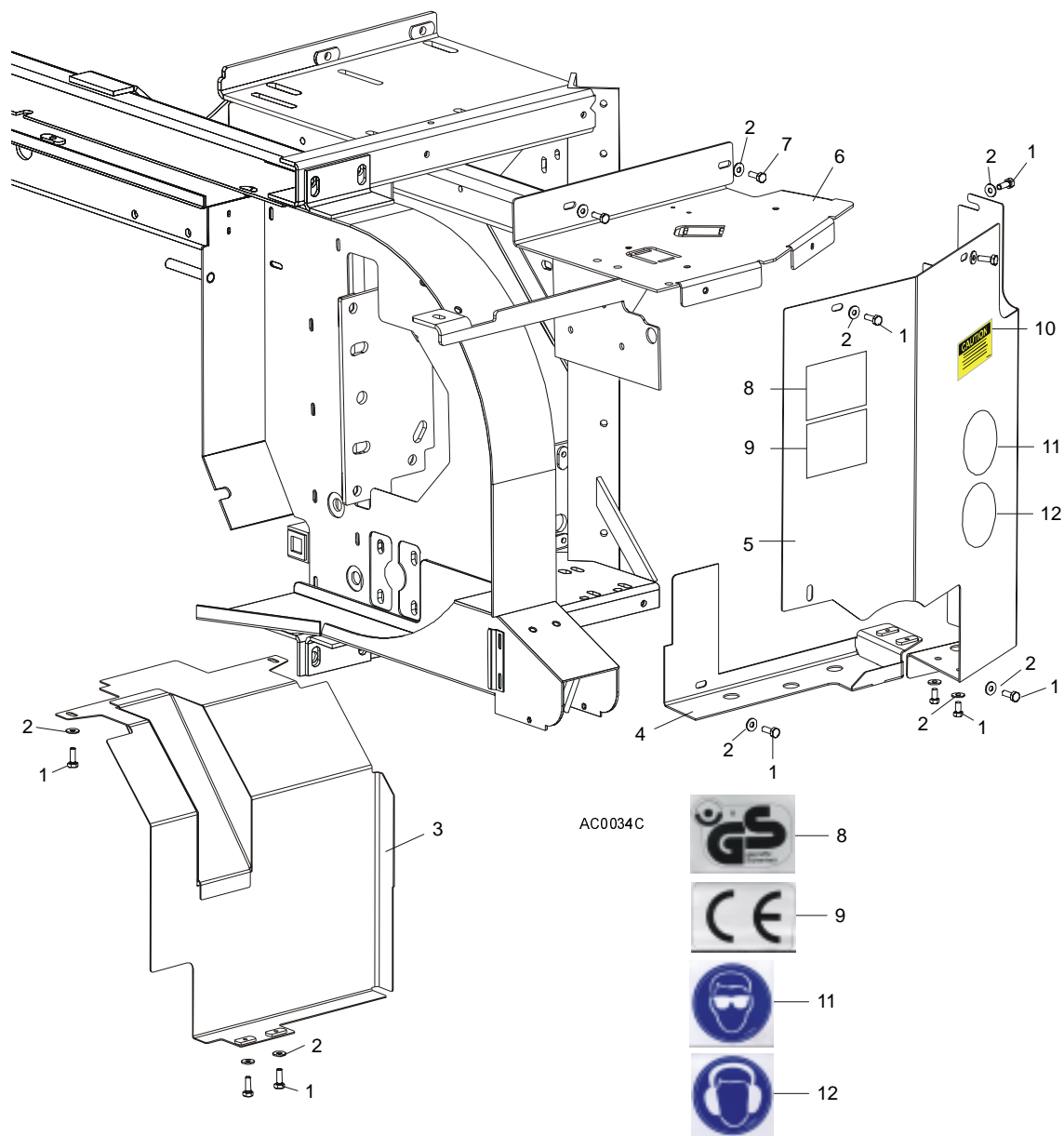

REF	DESCRIPTION (◆ Indicates Parts Available In Assemblies Only)	PART #	QTY.
1	BOLT, M6 X 12-8.8 HEX HEAD	F81001-7	11
2	WASHER, 6.5 FLAT	F81053-11	13
3	GUARD WELDMENT, AC	087660-1	1
4	MOUNT WELDMENT, AC LOWER UP/DOWN	087525-1	1
5	GUARD WELDMENT, AC C-FRAME ENCLOSURE	087334-1	1
6	GUARD, DRIVE PULLEY TOP	086621-1	1
7	BOLT, M6 X 20-8.8 HEX HEAD	F81001-2	2
8	DECAL, GS SAFETY CERTIFICATION	P85073	1
9	DECAL, CE CRTIFIED SAWMILL	P85071	1
10	DECAL, UP/DOWN MOVEMENT DANGER	A11762	1

4**Saw Head***Drive Belt Covers*

11	DECAL, EYE PROTECTION WARNING	S12004G	1	
12	DECAL, EAR PROTECTION WARNING	S12005G	1	

4.8 Sawdust Chute

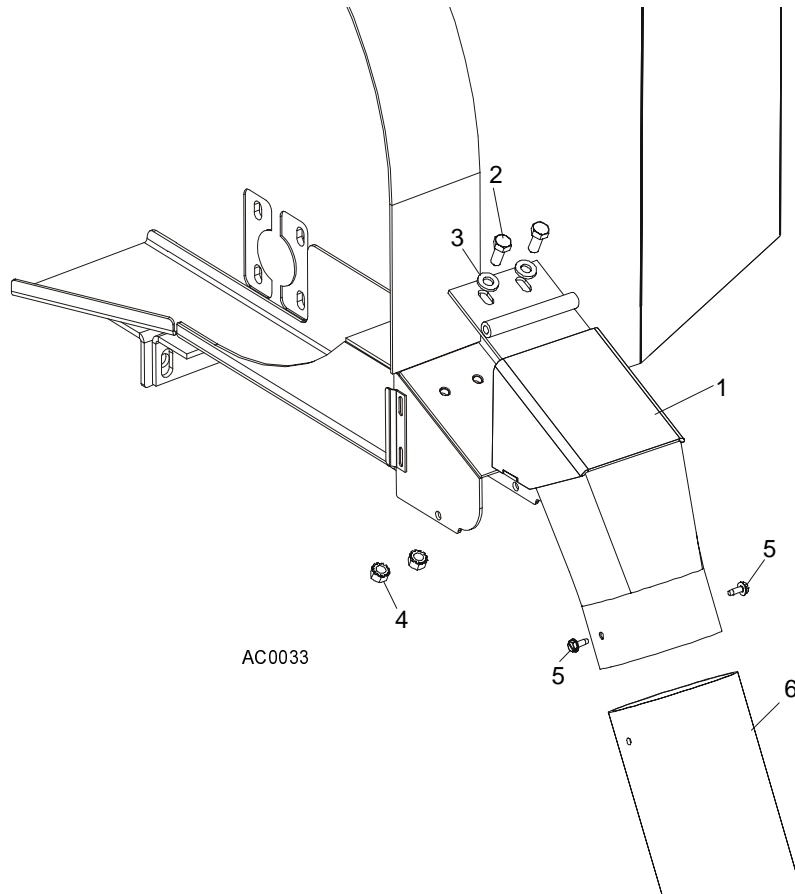

REF	DESCRIPTION (◆ Indicates Parts Available In Assemblies Only)	PART #	QTY.
1	CHUTE WELDMENT, SAWDUST	015466	1
2	BOLT, 5/16-18 X 3/4" HEX HEAD GRADE 2	F05006-5	2
3	WASHER, 8.4 FLAT	F81054-1	2
4	NUT, 5/16-18 SELF-LOCKING HEX	F05010-20	2
5	BOLT, #10-24 X 1/2" SELF-TAPPING	F05015-7	2
6	TUBING, 4" I.D. RUBBER	R02336	0.6 m
	STRAP, 20" RUBBER W/HOOK	P11668	1
	BOLT, 1/4-20 X 1 1/4" HEX HEAD FULL THREAD	F05005-3	1
	WASHER, 7.4 FLAT	F81056-11	1
	NUT, 1/4-20 LOCK	F05010-21	1

SECTION 5 CONTROL & BATTERY BOXES

5.1 Control Assembly, LT30AHD/LT40AHD Super

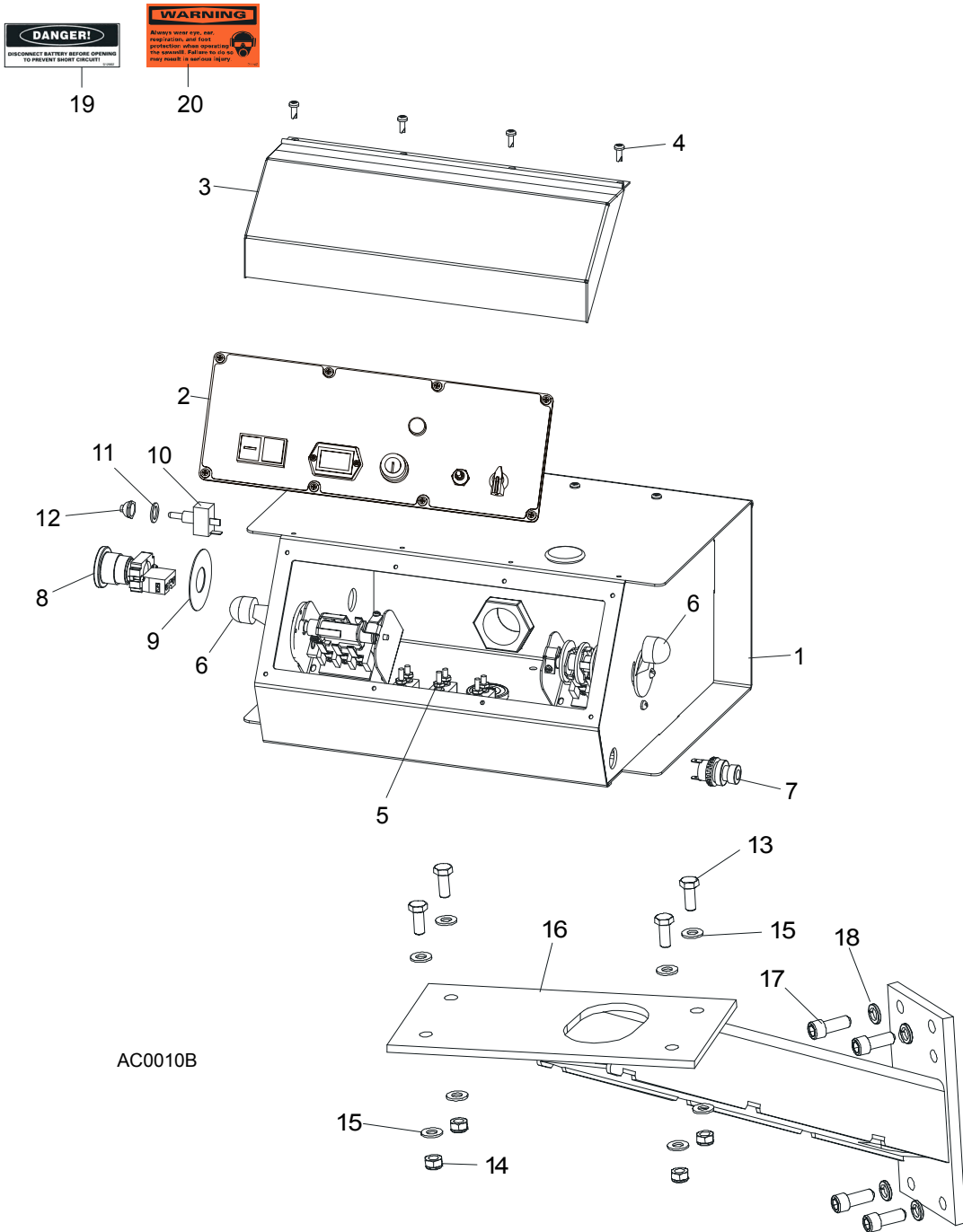

5 Control & Battery Boxes

Control Assembly, LT30AHD/LT40AHD Super

REF	DESCRIPTION (◆ Indicates Parts Available In Assemblies Only)	PART #	QTY.	
	CONTROL BOX ASSEMBLY, AC 2 SPEED	086548	1	
1	HOUSING, AC SUPER CONTROL BOX ASSEMBLY (EA20, EA25)	086546-1	1	◆
2	Front Control Panel & Wiring Harnesses (Section 5.4)			
3	Cover, Control Box Hinged	015304	1	
4	Screw, #10-24 x 1/2"	F05015-17	12	
5	Circuit Breakers (Section 5.3)			
6	Drum Switches (Section 5.2)			
7	Switch, Horn	E85118	1	
8	Switch, XB2 BS542 Emergency Stop	086556	1	
9	Washer, Emergency Stop Switch	086561	1	
10	Switch, SPST On/Off 15A .25 Tabs Toggle>	P03027	1	
11	Washer, 1/2" x 3/4" x 5/8" Nylon	P05251-1	1	
12	Boot, Speed Control Switch	P02575	1	
13	BOLT, M8 X 20-8.8-B HEX HEAD	F81002-4	4	
14	NUT, M8-8-B HEX	F81032-2	4	
15	WASHER, 8.4 FLAT	F81054-1	8	
16	MOUNT WELDMENT, STANDARD CONTROL BOX	086732-1	1	
17	BOLT,, 3/8-16 X 1" SOCKET HEAD	F05007-52	4	
18	WASHER, 10.2 SPLIT LOCK	F81055-2	4	
19	DECAL, FRONT OUTRIGGER WARNING	015400-4	1	
20	DECAL, EAR/EYE PROTECTION WARNING	S11753-4	1	

5.2 Drum Switches

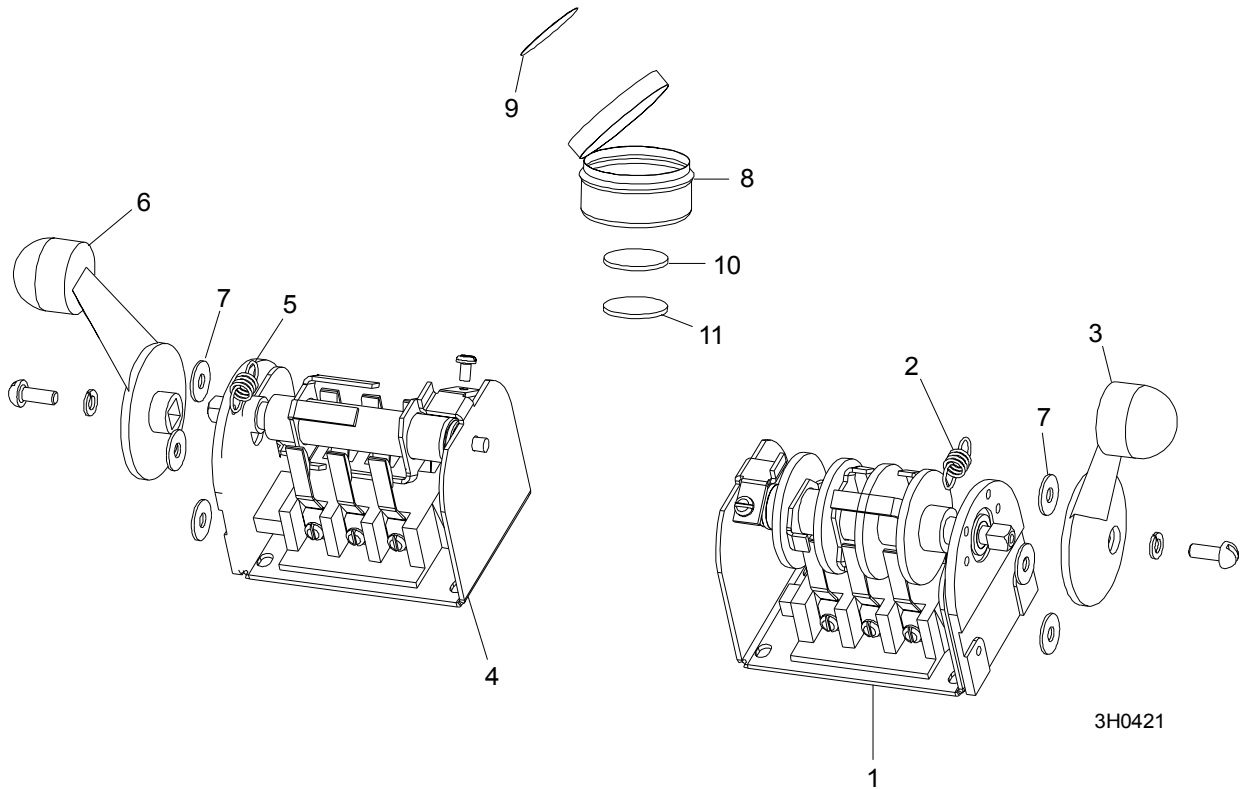

REF	DESCRIPTION (◆ Indicates Parts Available In Assemblies Only)	PART #	QTY.	
	SWITCH ASSEMBLY, UP/DOWN DRUM	E20440	1	
1	Switch, S12 Bulk Drum	E20440-B	1	◆
2	Spring, Drum Switch	P12570	1	
3	Handle, Drum Switch Replacement	P12500	1	
	SWITCH ASSEMBLY, POWER FEED DRUM	E20438	1	
4	Switch, S10 Bulk Drum	E20438-B	1	◆
5	Spring, Drum Switch	P12570	1	
6	Handle, Drum Switch Replacement	P12500	1	
7	WASHER, #8 SAE FLAT	F05011-41	6	
	CUP ASSEMBLY, DRUM SWITCH GREASE	A20463	1	
8	Cup, Plastic Container	P20464	1	◆
9	Decal, Grease Cup Label	P20467	1	
10	Pad, Velcro Loop	P20466	1	◆
11	Pad, Velcro Hook	P20465	1	◆
	Grease, High Temp Drum Switch	P20468	.011ml	◆

5.3 Circuit Breakers

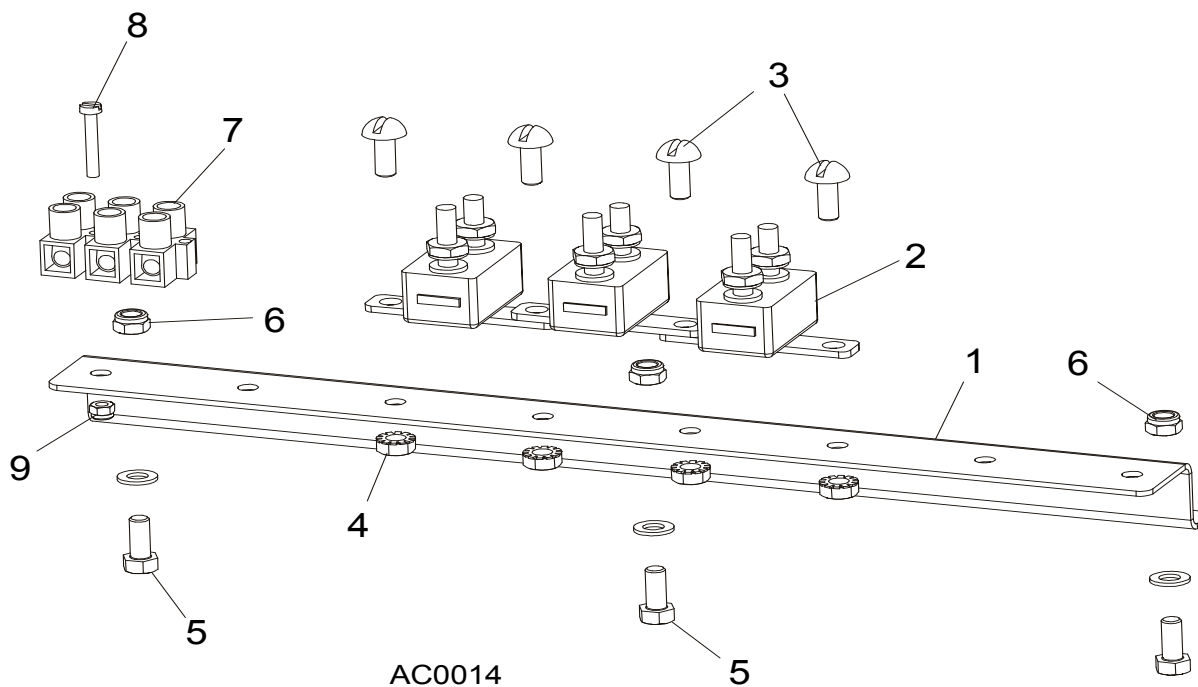

REF	DESCRIPTION (◆ Indicates Parts Available In Assemblies Only)	PART #	QTY.
1	RAIL, CIRCUIT BREAKER	015310	1
2	BREAKER, 15 AMP MANUAL RESET	E20430	5
3	SCREW, H M5X10 8.8 ZINC	F81000-13	4
4	NUT, M5-8 ZINC HEX SELF-LOCKING	F81030-2	4
5	SCREW, M5X12-5.8 ZINC	F81000-5	3
6	NUT, M5-8 ZINC HEX SELF-LOCKING	F81030-2	3
7	STRIP, ELECTRIC WIRE	F81086-1	1
8	SCREW, M3 X 20-5.8	F81000-8	1
9	NUT, M3	F81028-2	1

5.4 Front Panel Assembly & Harnesses

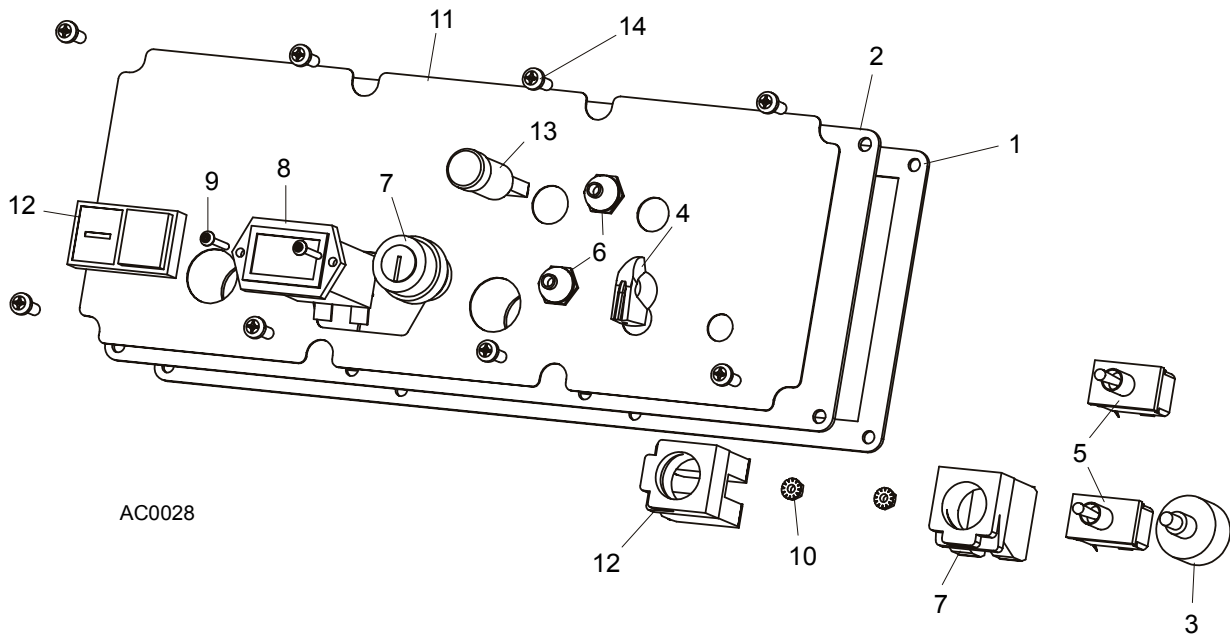

REF	DESCRIPTION (◆ Indicates Parts Available In Assemblies Only)	PART #	QTY.
	PANEL ASSEMBLY, AC SUPER CONTROL FRONT (EA20, EA25)	087387	1
1	Gasket, Front Panel	088387	1
2	Panel Weldment, Control	087316	1
3	Switch Assembly, Feed Rate	E20519	1
4	Knob, Feed Rate With Set Screw	P06257	1
5	Switch, Toggle	024200	2
6	Boot, Toggle Switch Rubber	P02575	2
7	Switch, Key	087350	1
8	Meter, Hour	015401	1
9	Bolt, M3x12 -8.8 Zinc	F81000-12	2
10	Nut, M3-6 Zinc	F81028-2	2
11	Decal, Control Pane	087351	1
12	Switch, START-STOP	087349	1
13	Lamp, Control	087348	1
	HARNESS ASSEMBLY, UPPER WIRING	024215	1
	HARNESS ASSEMBLY, LOWER WIRING	015421	1
14	Screw, #10-24 x 1/2" Pan Head	F05015-17	8

SECTION 6 UP/DOWN SYSTEM

6.1 Saw Head V-Brace Mount

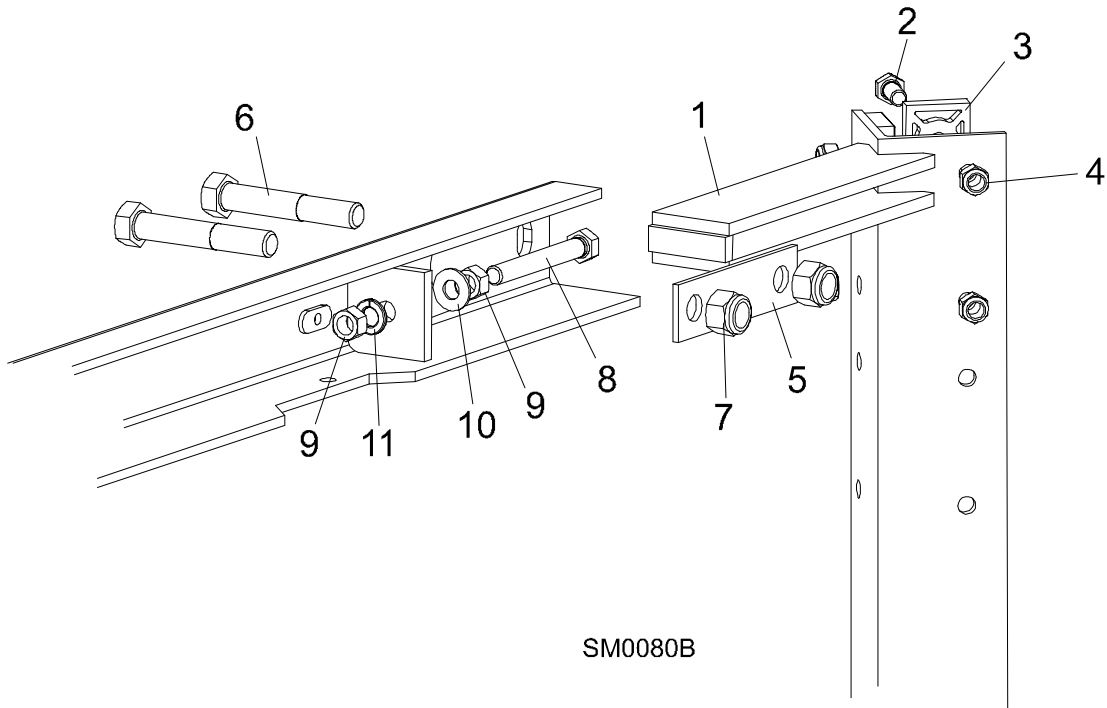

REF	DESCRIPTION (◆ Indicates Parts Available In Assemblies Only)	PART #	QTY.	
1	V-BRACE, SAW HEAD MOUNT	086308	1	
2	BOLT, 5/16-18 X 3/4" HEX HEAD GRADE 5	F05006-5	19	
	BOLT, 5/16-18 X 1 1/4" HEX HEAD FULL THREAD	F05006-18	5	
3	PAD, PLASTIC SLIDE	M04096	12	
4	NUT, 5/16-18 NYLON LOCK	F05010-58	19	
	NUT, 5/16-18 HEX	F05010-17	5	
5	PLATE, V-BRACE WASHER	091247	4	
6	BOLT, M12 X 40 - 8.8 HEX HEAD	F81004-1	4	
7	NUT, M12 - 8 NYLON LOCK	F81034-2	4	
8	BOLT, 3/8-16 X 3" FULL THREAD	F05007-1	2	
9	NUT, 3/8-16 HEX	F05010-1	4	
10	WASHER, 10.5 FLAT	F81055-1	2	
11	WASHER, 10.2 SPLIT LOCK	F81055-2	2	

6.2 Blade Height Scale

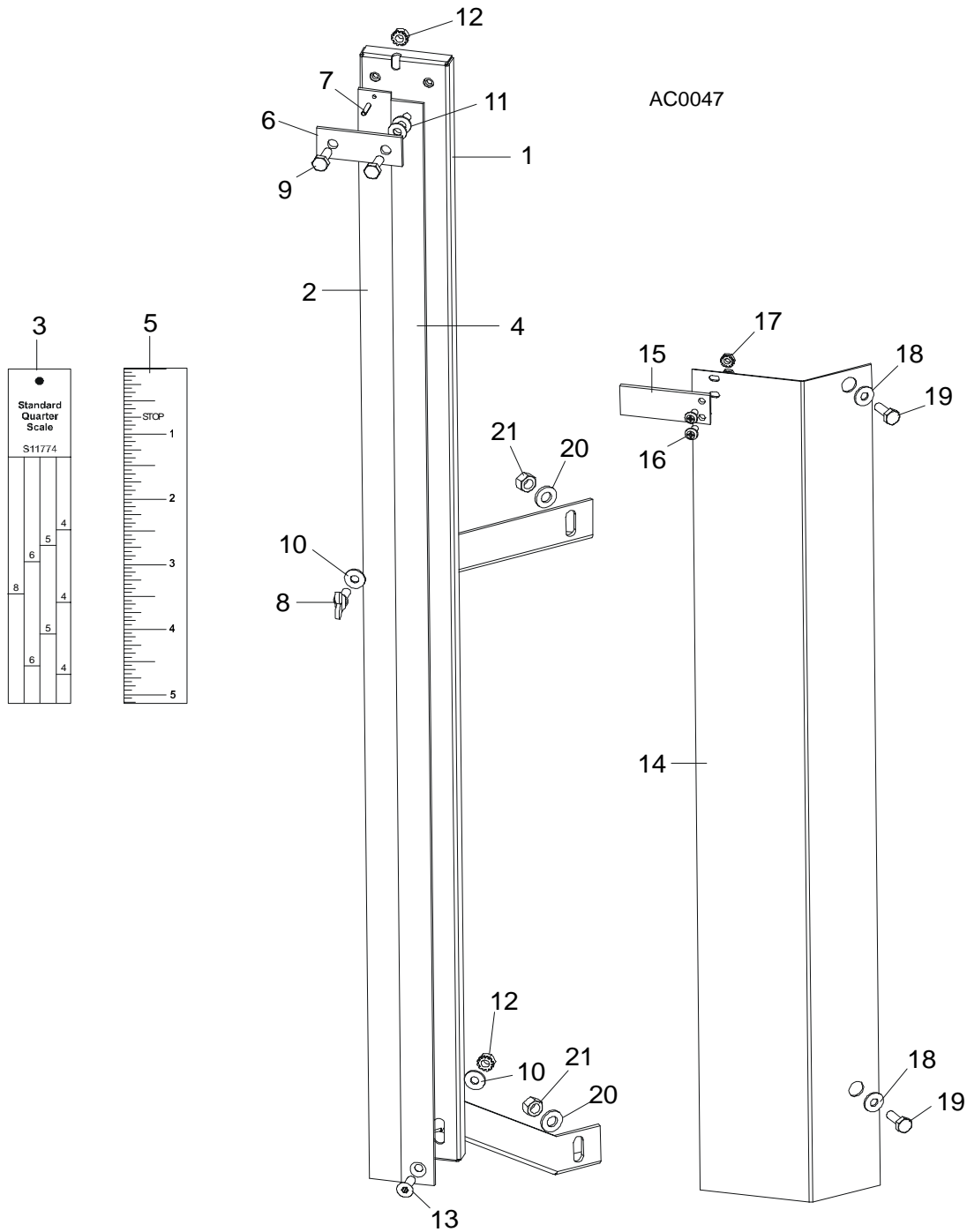

REF	DESCRIPTION (◆ Indicates Parts Available In Assemblies Only)	PART #	QTY.
	SCALE RETROFIT, FIXED WITH POINTER	A12030	1

	Scale Kit, Fixed With Pointer	K11998	1	◆
	Scale Assembly, Fixed	A12022	1	◆
1	Bracket, Scale Mounting	W11996	1	
2	Scale, 35" Quarter	S11989	1	
3	Decal, 35" Standard Quarter Scale	S11774	1	
	Decal, 35" Grade Hardwood Quarter Scale	P12819	1	
4	Scale, 35" Inch	S11988	1	
5	Decal, 35" Inch	S11773	1	
6	Strap, Scale Hold-Down	S04805	1	
7	Pin, 1/8" X 5/8" Roll	F05012-14	1	
8	Screw, 1/4-20 X 5/8" Wing	F05005-64	1	
9	Bolt, 1/4-20 X 3/4" Hex Head Full Thread	F05005-1	2	
10	Washer, 7.4 Flat	F81056-11	2	
11	Washer, 1/4" X .020 Thick Nylon Flat	F05011-22	2	
12	Nut, 1/4-20 Hex Self-Locking	F05010-9	2	
13	Screw, 1/4-20 X 3/4" Flat Socket Head	F05005-70	1	
	Pointer Assembly, Fixed Scale	A12023	1	
14	Bracket, Fixed Scale Pointer Mount	S12245	1	◆
15	Pointer, Fixed Scale	086691	1	
16	Screw, #10-24 X 3/8" Phillips Head	F05004-3	2	
17	Nut, #10-24 Hex Self-Locking	F05010-14	2	
18	Washer, 7.4 Flat	F81056-11	2	
19	Bolt, 1/4-20 x 1/2" Hex Head	F05005-1	2	
20	Washer, 8.4 Flat	F81054-1	2	
21	Nut, 5/16-18 Hex Lock	F05010-6	2	
	Bolt, 1/4-20 X 1/2" Hex Head Grade 2	F05005-15	1	
	Instruction Sheet, Fixed Scale Retrofit	A12030-370	1	
	DECAL KIT, METRIC SCALE	K12064	1	
	Decal, Metric	S11711	1	
	Decal, Metric 16-40mm	P12040-1	1	
	Decal, Metric 45-63mm	P12040-2	1	

6.3 Up/Down Chain & Sprockets

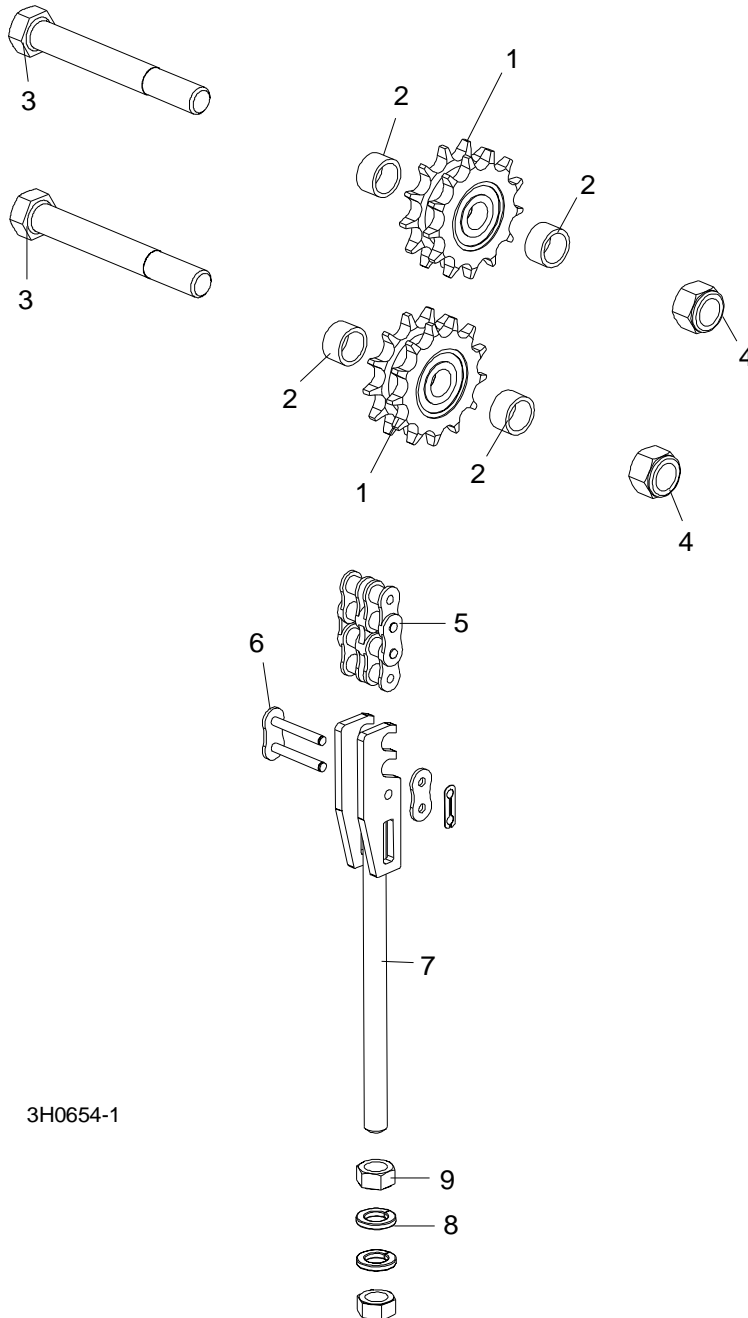

REF	DESCRIPTION (◆ Indicates Parts Available In Assemblies Only)	PART #	QTY.
	SPROCKET KIT, UP/DOWN IDLER #50-2	016020	1
1	Sprocket, Up/Down Idler '98	016019	2
2	Spacer, 50-2 Idler '98	016018	4

	Instruction Sheet, Up/Down Idler Retrofit	016020-541	1	
3	BOLT, 5/8-11 X 5" HEX HEAD GRADE 2	F05009-6	2	
4	NUT, 5/8-11 HEX NYLON LOCK	F05010-34	2	
5	CHAIN, #50-2 X 75.625" UP/DOWN	015259	1	
6	LINK, #50-2 MASTER	015258	2	
	TENSIONER ASSEMBLY, UP/DOWN CHAIN	086219	1	
7	Bracket, Up/Down #50 Chain Tensioner	086205-1	1	◆
8	Washer, 12.2 Split Lock	F81056-2	2	
9	Nut, M12-8-B Hex	F81034-1	2	

6.4 Up/Down Motor Assembly, LT30AHD/LT40AHD Super

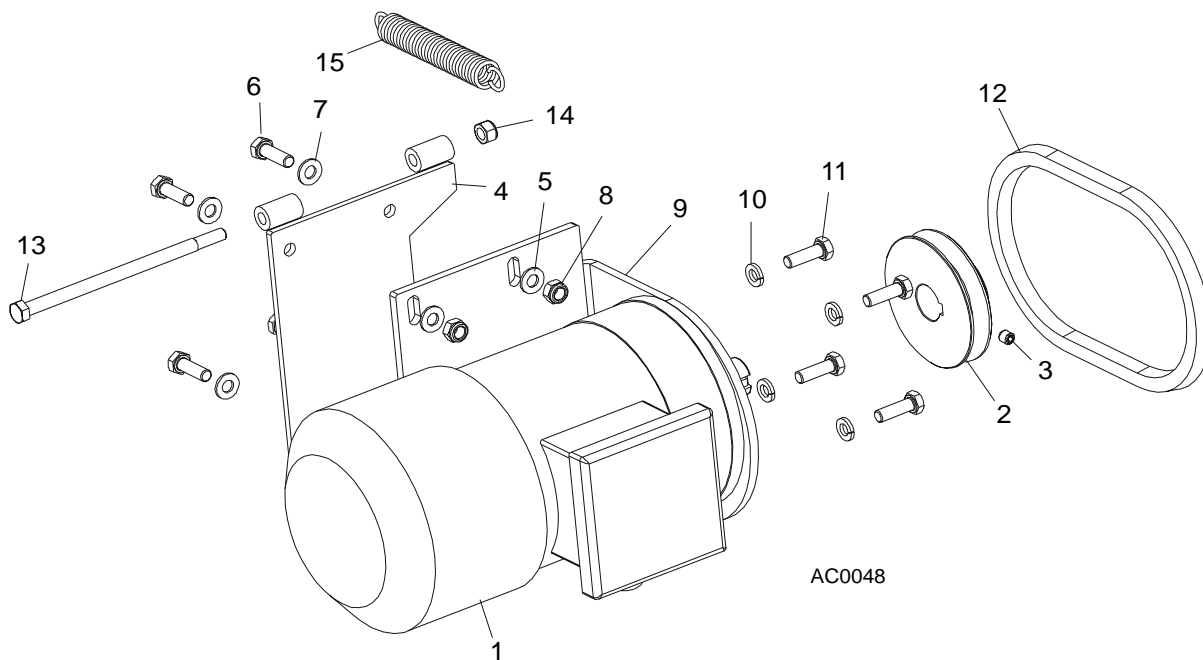

REF	DESCRIPTION (◆ Indicates Parts Available In Assemblies Only)	PART #	QTY.
	UP/DOWN 2-SPEED MOTOR ASSEMBLY, AC SUPER	086871	1
1	Motor, 2-Speed AC Super	086770	1
2	Pulley, Up/Down Motor	086378-1	1
3	Screw, M8 X 8	F81014-1	1
4	Bracket, Up/Down Motor Mount	015198	1
5	Washer, 8.4 Split Lock	F81054-1	4
6	Bolt, M8 x 25 8.8 B Hex Head	F81002-4	4
7	Washer, 8.4 Flat	F81054-1	4
8	Nut, M8 8 B Hex	F81032-2	4
9	Bracket, AC Up/Down Motor Mount	086376-1	1
10	Washer, 3/8" Split Lock	F05011-4	2
11	Bolt, 3/8-16 x 3/4" Hex Head	F05007-27	4
12	BELT, AX23	015257	1
13	BOLT, 5/16-18 X 6" HEX HEAD GRADE 5	F05006-73	1
14	NUT, 5/16-18 HEX NYLON LOCK	F05010-65	1
15	SPRING, .75" X 5" X .095" EXTENSION	015569	1

6.5 Up/Down Drive Assembly

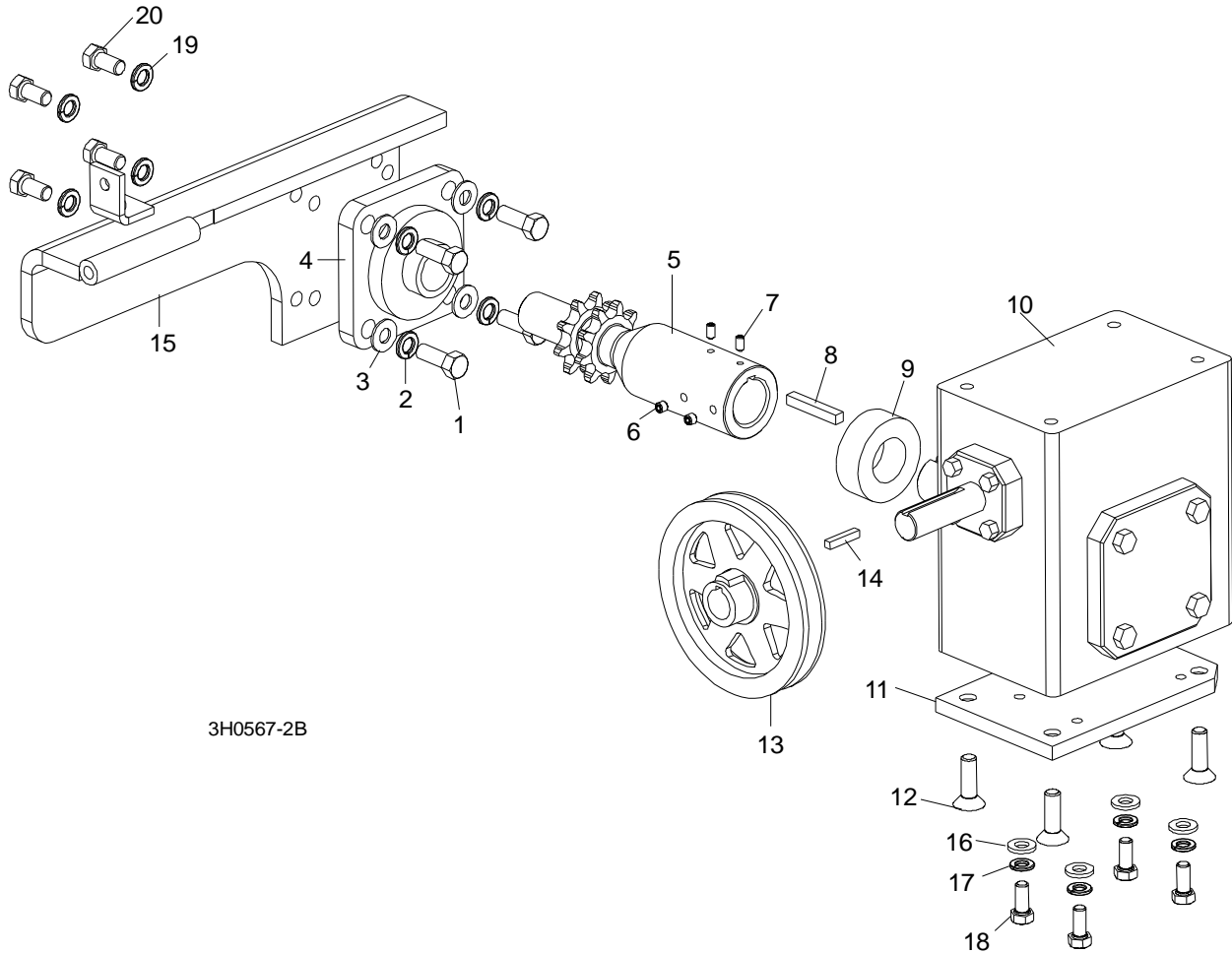

REF	DESCRIPTION (◆ Indicates Parts Available In Assemblies Only)	PART #	QTY.
	UP/DOWN DRIVE ASSEMBLY	015176-0	1
1	Bolt, 3/8-16 x 1" Hex Head	F05007-7	4
2	Washer, 10.2 Split Lock	F81055-2	4
3	Washer, 10.5 Flat	F81055-1	4
4	Bearing, Flanged Up/Down	014090	1
5	Shaft, Up/Down Sprocket	086587	1
6	Screw, M8 x 8-33H	F81014-1	2
7	Screw, M8 x 8-33H	F81014-1	2
8	Key, 1/4" Square x 1 11/16" Long	S04124	1
9	Spacer, Up/Down Shaft	016032	1
10	Reducer, Gear Box	014074	1
11	Plate, Gear Box Spacer	014158-1	1

6

Up/Down System*Up/Down Drive Assembly*

12	Bolt, 3/8-16 x 1" Flat Socket Head	F05007-110	4	
13	Pulley, Up/Down	015256	1	
14	Key, 3/16" Square x 1" Long	S31027	1	
15	Bracket, Up/Down Motor Mount	015195-1	1	
16	WASHER, 8.4 FLAT	F81054-1	4	
17	WASHER, 8.2 SPLIT LOCK	F81054-4	4	
18	BOLT, 5/16-18 X 1" HEX HEAD	F05006-5	4	
19	WASHER, 10.2 SPLIT LOCK	F81055-2	4	
20	BOLT, 3/8-16 X 3/4" HEX HEAD	F05007-27	4	
	OIL, 8 OZ. MOBIL SHC634 BOTTLED SYNTHETIC GEAR	L04869-4	1	

SECTION 7 POWER FEED & TRACK ROLLERS

7.1 Upper Track Rollers And Wipers

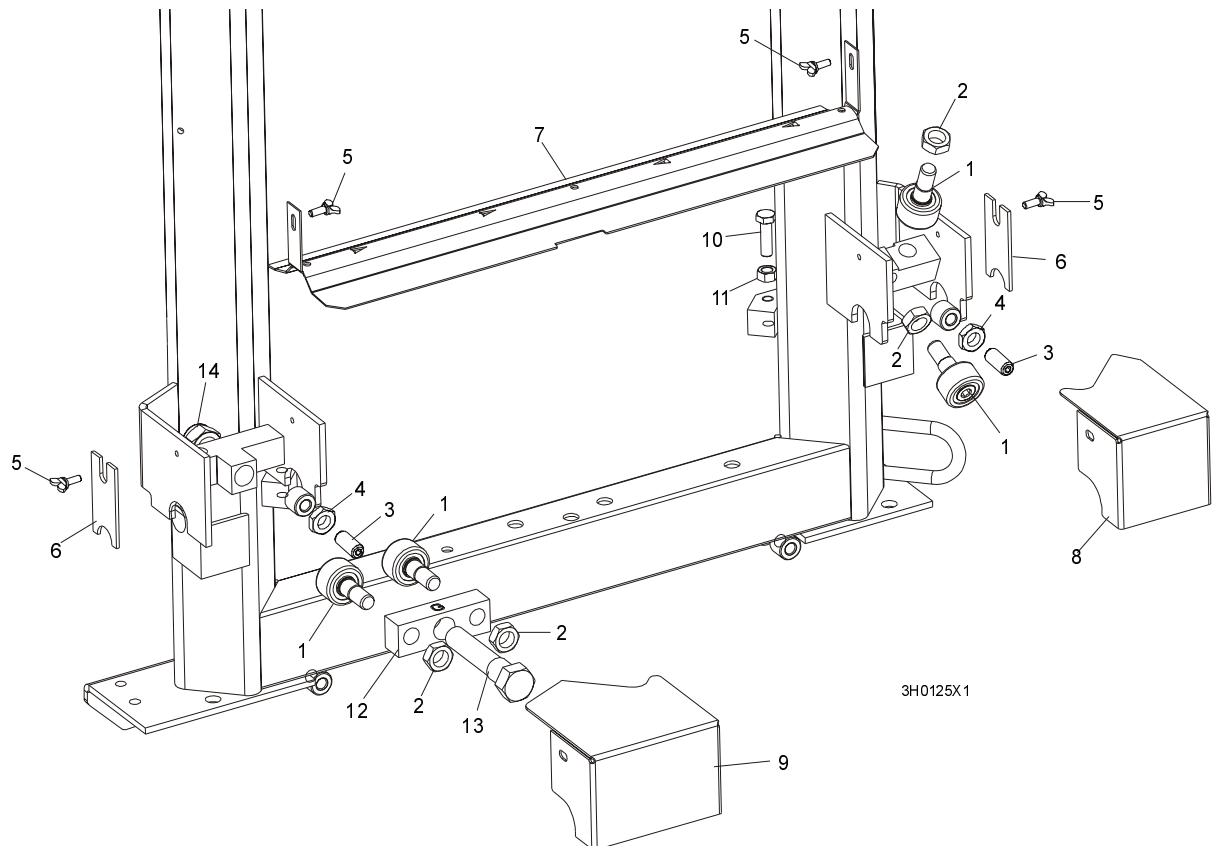

REF	DESCRIPTION (◆ Indicates Parts Available In Assemblies Only)	PART #	QTY.
1	ROLLER, TRACK CAM BEARING	P12843	4
2	NUT, 5/8-18 HEX JAM	F05010-11	4
3	SCREW, M12 X 30 OVAL POINT SET	F81004-14	2
4	NUT, M12-8-B HEX JAM	F81034-1	2
5	SCREW, M6 X 16 THUMB	F81001-16	4
6	WIPER, PLASTIC TRACK	M04113	2
7	COVER, MIDDLE TRACK OILER	S09917	1
	Wiper, Middle Track Felt	S09915	1
8	HOUSING, UPPER TRACK ROLLER REAR	086913-1	1
9	HOUSING, UPPER TRACK ROLLER FRONT	086914-1	1
10	BOLT, M10 X 35-8.8 HEX HEAD	F81003-17	2
11	NUT, M10-8 HEX JAM	F81033-3	2
12	BRACKET, UPPER TRACK ROLLER	086859-1	1
13	BOLT, HEX HEAD	086911	1
14	NUT, M20-8 HEX	F81037-2	1

7 Power Feed & Track Rollers

Power Feed Assembly, LT30AHD/LT40AHD Super

7.2 Power Feed Assembly, LT30AHD/LT40AHD Super

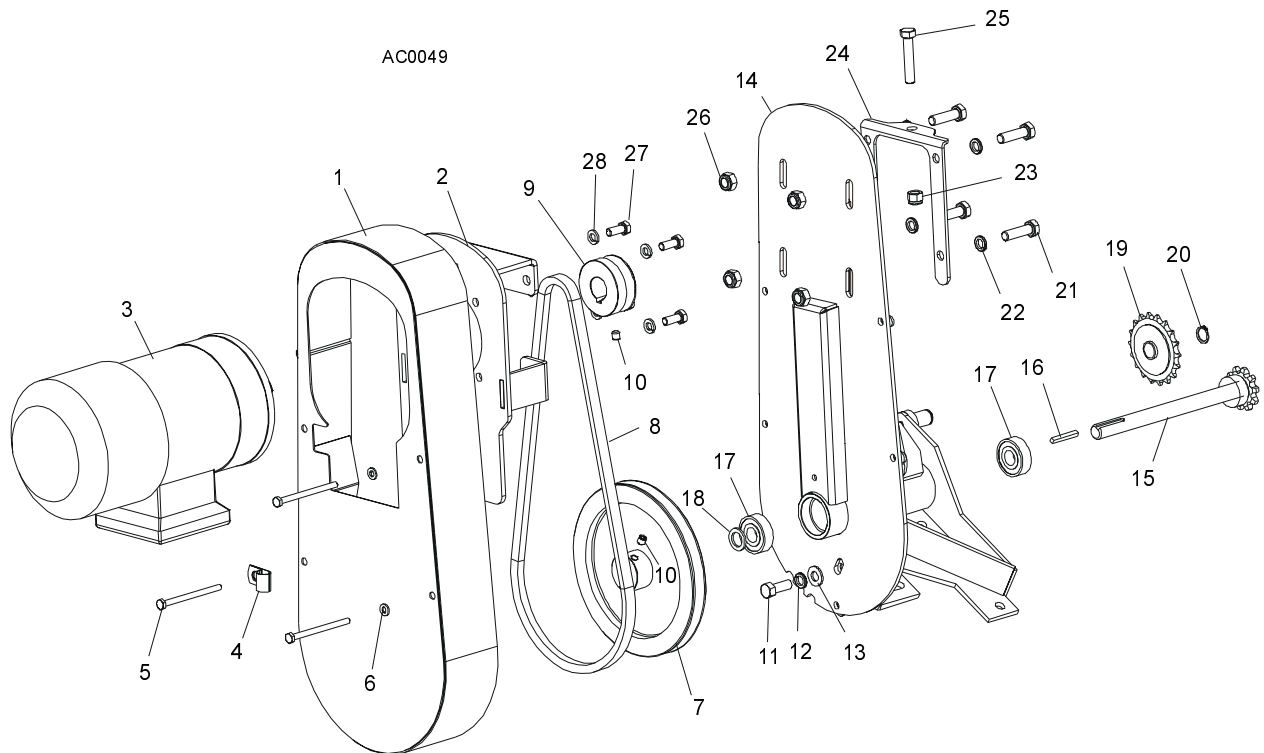

REF	DESCRIPTION (◆ Indicates Parts Available In Assemblies Only)	PART #	QTY.
	POWER FEED ASSEMBLY, AC SUPER	086522	1
1	Cover Weldment, Top Power Feed	015128	1
2	Plate, Power Feed Motor	086390	1
3	Motor, 1100 W Power Feed Painted, AC Super	086530	1
4	Clamp, 1/2" EMT Coated	P07584	1
5	Bolt, M6 x 80 5.8 Hex Head Grade	F81001-61	4
6	Washer, 6.4 Flat	F81053-1	4
7	Sheave, Power Feed	086410-1	1
8	Belt, Power Feed	086532	1
9	Sheave, Feed Motor	086388-1	1
10	Screw, M8 X 8	F81014-1	2
11	Bolt, 3/8-16 x 1" Hex Head	F05007-7	1
12	Washer, 3/8" Split Lock	F05011-4	5
13	Washer, 3/8" Flat	F05011-3	5
14	Bracket, Power Feed Mount	015162	1
15	Shaft Weldment, Power Feed	015129	1
16	Key, 3/16" Square x 1 3/8" Long	016108	1
17	Bearing, 5/8" 6203-2NSL	P06030-1	2
18	Washer, 5/8" x 15/16" x .094" Nylon	F05011-19	1
19	Sprocket, 40 Idler 18T 5/8" ID	P04333	1
20	Ring, Z15	F81090-2	1

Power Feed & Track Rollers

Power Feed Assembly, LT30AHD/LT40AHD Super

7

21	Bolt, Hex Head	F81003-17	4	
22	Washer, Flat	F81055-2	1	◆
23	Nut, 3/8-16 Hex Nylon Lock	F05010-10	1	
24	Bracket, Power Feed Mount	015162-1	1	
25	Bolt, 3/8-16 x 2" Full Thread Hex Head	F05007-16	1	
26	Nut, 3/8-16 Hex Nylon Lock	F81033-1	1	
27	Bolt, Hex Head	F81002-4	4	
28	Washer, Flat	F81054-4	4	

7.3 Feed Chain/Stop

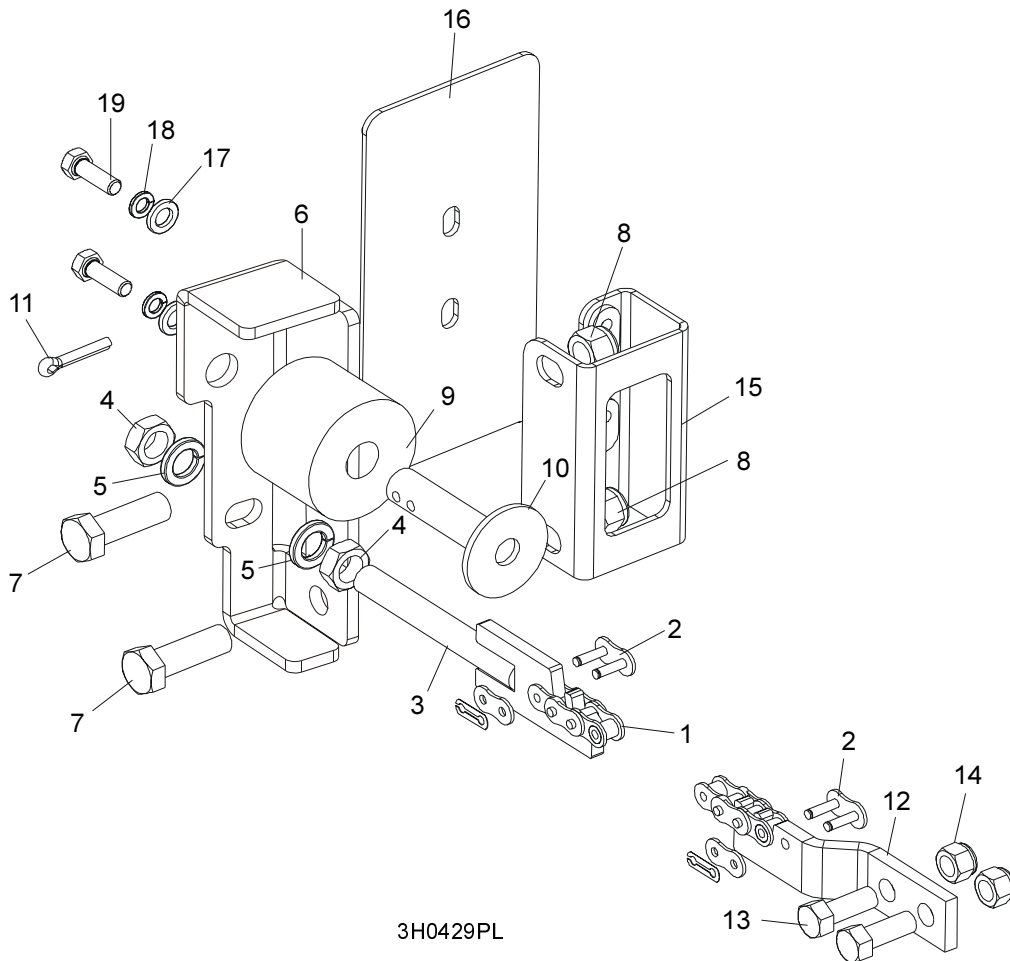

3H0429PL

REF	DESCRIPTION (◆ Indicates Parts Available In Assemblies Only)	PART #	QTY.
	CHAIN KIT, LT30 FEED	K10408	1
	CHAIN KIT, LT40 FEED	K10410	1
1	Chain, #40 X 215" LT30 Feed	014744	1
	Chain, #40 X 267.5" LT40 Feed	014475	1
2	Link, #40 Master	P04200	2
3	Tensioner Weldment, Power Feed Chain	086818-1	1
4	Nut, M12-5 Hex Jam	F81034-4	2
5	Washer, 12.2 Split Lock	F81056-2	2
6	BRACKET, FEED CHAIN REAR MOUNT	087628-1	1
7	BOLT, M12 X 40 8.8 HEX HEAD GRADE 5	F81004-4	2
8	NUT, M12-8 HEX NYLON LOCK	F81034-2	2
	STOP KIT, RUBBER CARRIAGE	K09630	2
9	Stop, Rubber Carriage	P12165	1
10	Pin, Rubber Carriage Stop	W09293	1
11	Pin, 3/16" X 1" Cotter	F05012-21	1
12	BRACKET, FRONT FEED CHAIN MOUNT	015008	1

13	BOLT, 3/8-16 X 1" HEX HEAD	F05007-7	2	
14	NUT, 3/8-16 HEX NYLON LOCK	F05010-10	2	
15	BRACKET WELDMENT, REAR MAIN TUBE COVER MOUNT	087105-1	1	
16	COVER, REAR MAIN TUBE	015023	1	
17	WASHER, 8.4 FLAT	F81054-1	2	
18	WASHER, 8.2 SPLIT LOCK	F81054-4	2	
19	BOLT, 5/16-18 X 1" HEX HEAD	F05006-1	2	

7.4 Lower Track Rollers

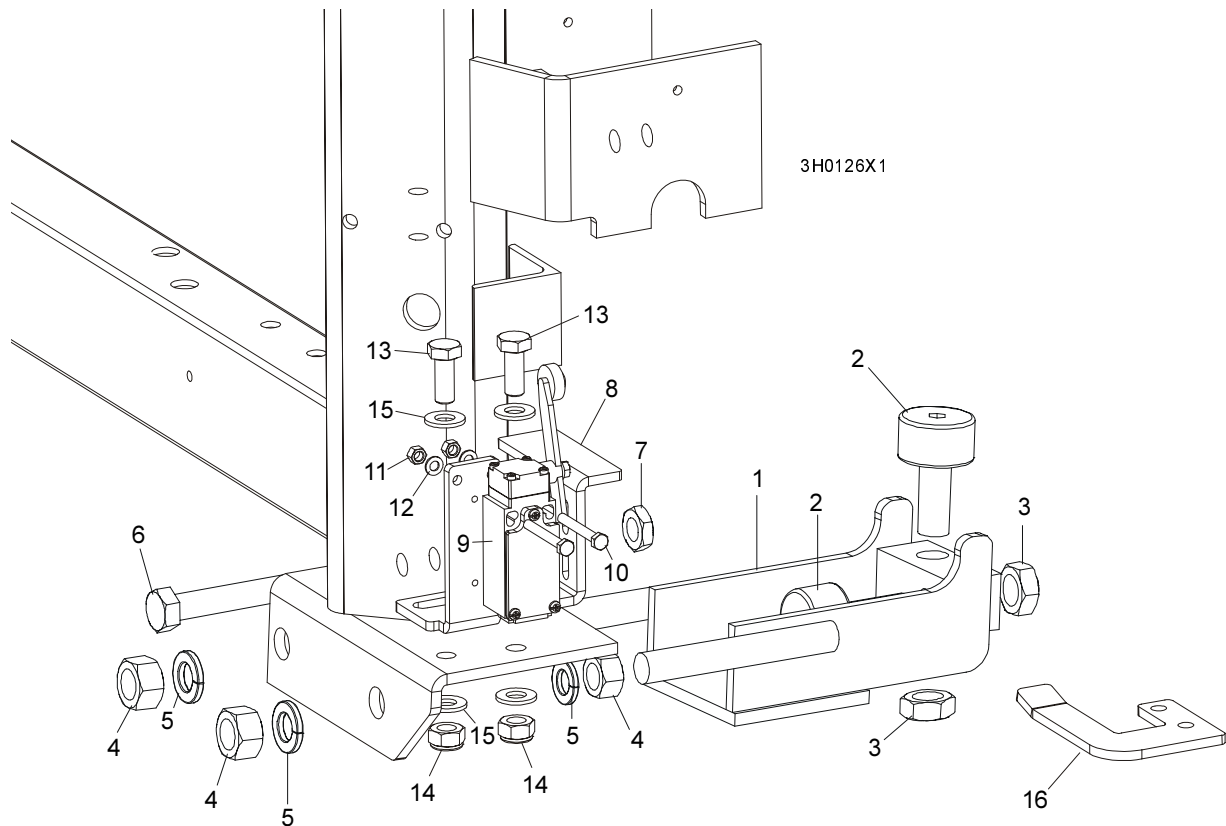

REF	DESCRIPTION (◆ Indicates Parts Available In Assemblies Only)	PART #	QTY.	
	ROLLER ASSEMBLY, LOWER TRACK	012995	2	
1	Bracket, Lower Track Roller Mounting	012982	1	◆
2	Roller, Track Cam Bearing	P12843	2	
3	Nut, 5/8-18 Hex Jam	F05010-11	2	
4	Nut, 5/8-11 Hex	F05010-5	4	
5	Washer, 16.3 Split Lock	F81058-2	4	
6	BOLT, M12 X 55-8.8 HEX HEAD FULL THREAD	F81004-12	2	
7	NUT, M12-8-B HEX JAM	F81034-1	2	
8	BRACKET, POWER SUPPLY STRIP AND LIMIT SWITCH	086380-1	1	
9	SWITCH, GLCB01A2B LIMIT	086469	1	
10	BOLT, M5 X 40 8.8 HEX HEAD	F810000-11	2	
11	NUT, M5-8	F81030-1	2	
12	WASHER, 5.3 FLAT	F81052-1	2	
13	BOLT, M10 X 25 8.8	F81003-11	2	
14	NUT, M10 NYLON	F81033-1	2	
15	WASHER, 10.5 FLAT	F81055-1	2	
16	BRACKET, LIMIT SWITCH	086473-1	1	

SECTION 8 BED FRAME ASSEMBLY

8.1 Bed Rail Assembly, Front And Rear

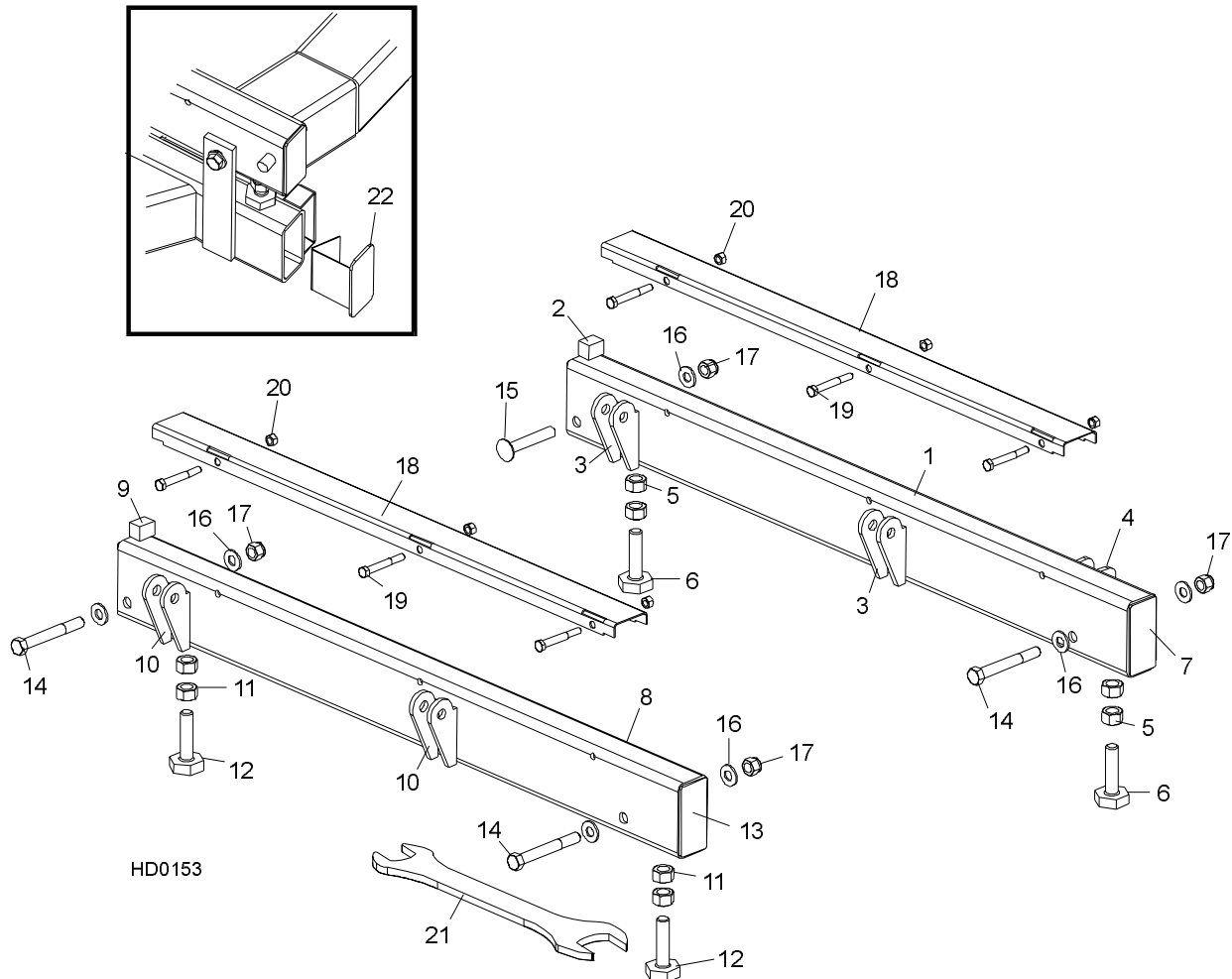

HD0153

REF	DESCRIPTION (◆ Indicates Parts Available In Assemblies Only)	PART #	QTY.	
	BED RAIL ASSEMBLY, REAR PAINTED	014467	1	
1	Bed Rail Tube, Long	015974	1	◆
2	Block, Log Stop	S09034	1	
3	Bracket, Roller Toe Board Mount	S13021	4	◆
4	Bracket, Saw Head Rest Pin Mount	014150	2	◆
	Bolt Assembly, Bed Rail	086809	2	◆
5	Nut, 5/8-11 Hex	F05010-54	2	
6	Bolt, Bed Rail Adjustment	S13006	1	
7	Plate, Bed Rail End Cap	S04058	2	◆
	BED RAIL ASSEMBLY, FRONT PAINTED	014455	1	
8	Bed Rail Tube, Long	015974	1	◆
9	Block, Log Stop	S09034	1	
10	Bracket, Roller Toe Board Mount	S13021	4	◆

8

Bed Frame Assembly*Bed Rail Assembly, Front And Rear*

	Bolt Assembly, Bed Rail	086809	2	◆
11	Nut, 5/8-11 Hex	F05010-54	2	
12	Bolt, Bed Rail Adjustment	S13006	1	
13	Plate, Bed Rail End Cap	S04058	2	◆
14	BOLT, M12 X 100-8.8 HEX HEAD	F81004-3	3	
15	BOLT, 1/2-13 X 3 1/2" CARRIAGE	F05008-94 ¹	1	
16	WASHER, 13 FLAT	F81056-1	7	
17	NUT, M12-8 NYLON LOCK	F81034-2	4	
	COVER ASSEMBLY, STAINLESS STEEL BED RAIL (LONG)	A09956	2	
18	Cover, Stainless Steel Bed Rail	S09944	1	◆
19	Bolt, 5/16-18 X 2 1/2" Hex Head	F05006-10	3	
20	Nut, 5/16-18 Hex Lock	F05010-6	3	
21	WRENCH, BED RAIL ADJUSTMENT	015970	1	
22	CAP WELDMENT, BED RAIL REMOVABLE END	014652	2	

¹ Used on rear bed rail to allow clearance for side support rollers.

8.2 Bed Rail Assembly, Front Middle

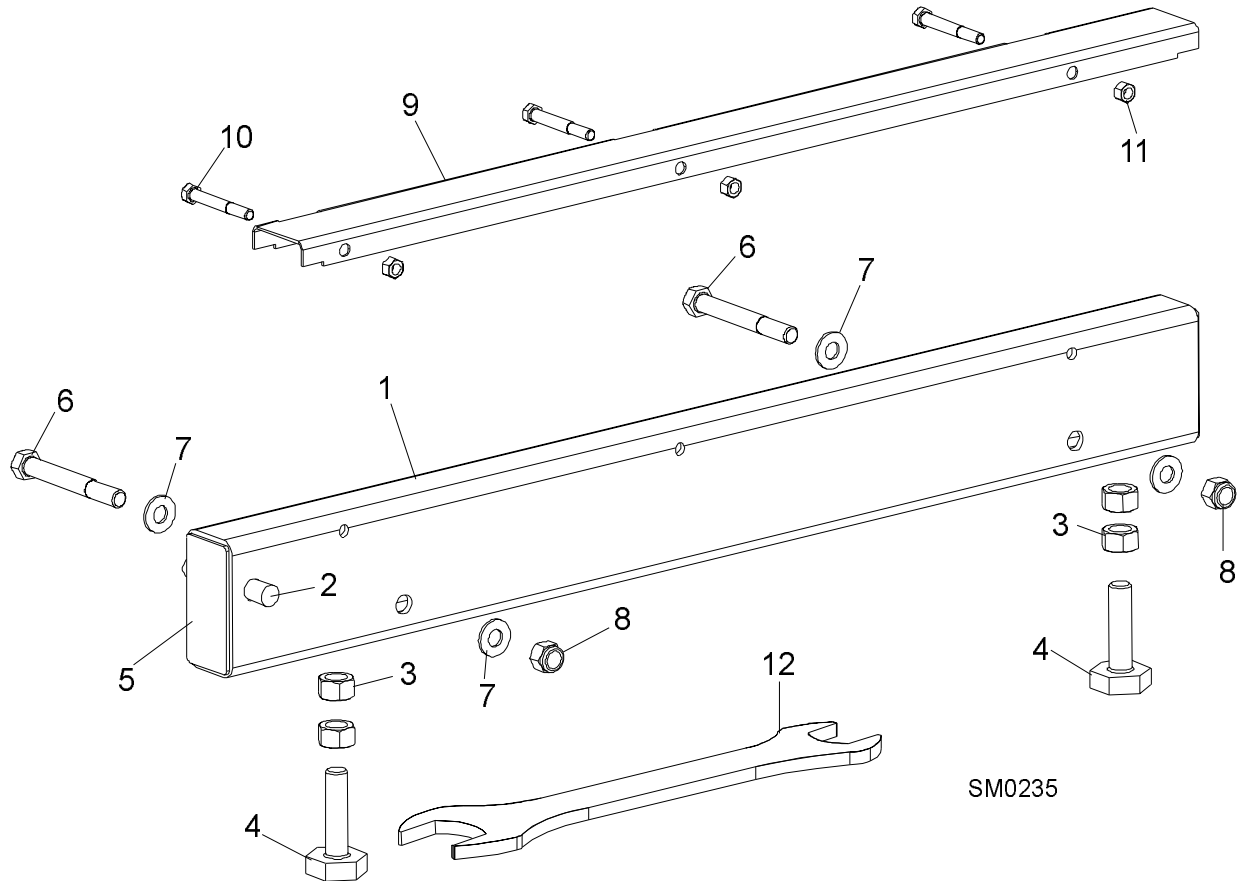

REF	DESCRIPTION (◆ Indicates Parts Available in Assemblies Only)	PART #	QTY.	
	BED RAIL ASSEMBLY, FRONT MIDDLE	A09566	1	
1	Bed Rail Tube, Short	S09103	1	◆
2	Pin, Ramp Mount	S04030	1	
	Bolt Assembly, Bed Rail	086809	2	◆
3	Nut, 5/8-11 Hex	F05010-54	2	
4	Bolt, Bed Rail Adjustment	S13006	2	
5	Plate, Bed Rail End Cap	S04058	2	◆
6	BOLT, M12 X 100-8.8 HEX HEAD	F81004-3	2	
7	WASHER, 13 FLAT	F81056-1	4	
8	NUT, M12-8 NYLON LOCK	F81034-2	2	
	COVER ASSEMBLY, STAINLESS STEEL BED RAIL (LONG)	A09956	1	
9	Cover, Stainless Steel Bed Rail	S09944	1	◆
10	Bolt, 5/16-18 X 2 1/2" Hex Head	F05006-10	3	
11	Nut, 5/16-18 Hex Lock	F05010-6	3	
12	WRENCH, BED RAIL ADJUSTMENT	015970	1	

8 Bed Frame Assembly

Bed Rail Assembly, Rear Middle

8.3 Bed Rail Assembly, Rear Middle

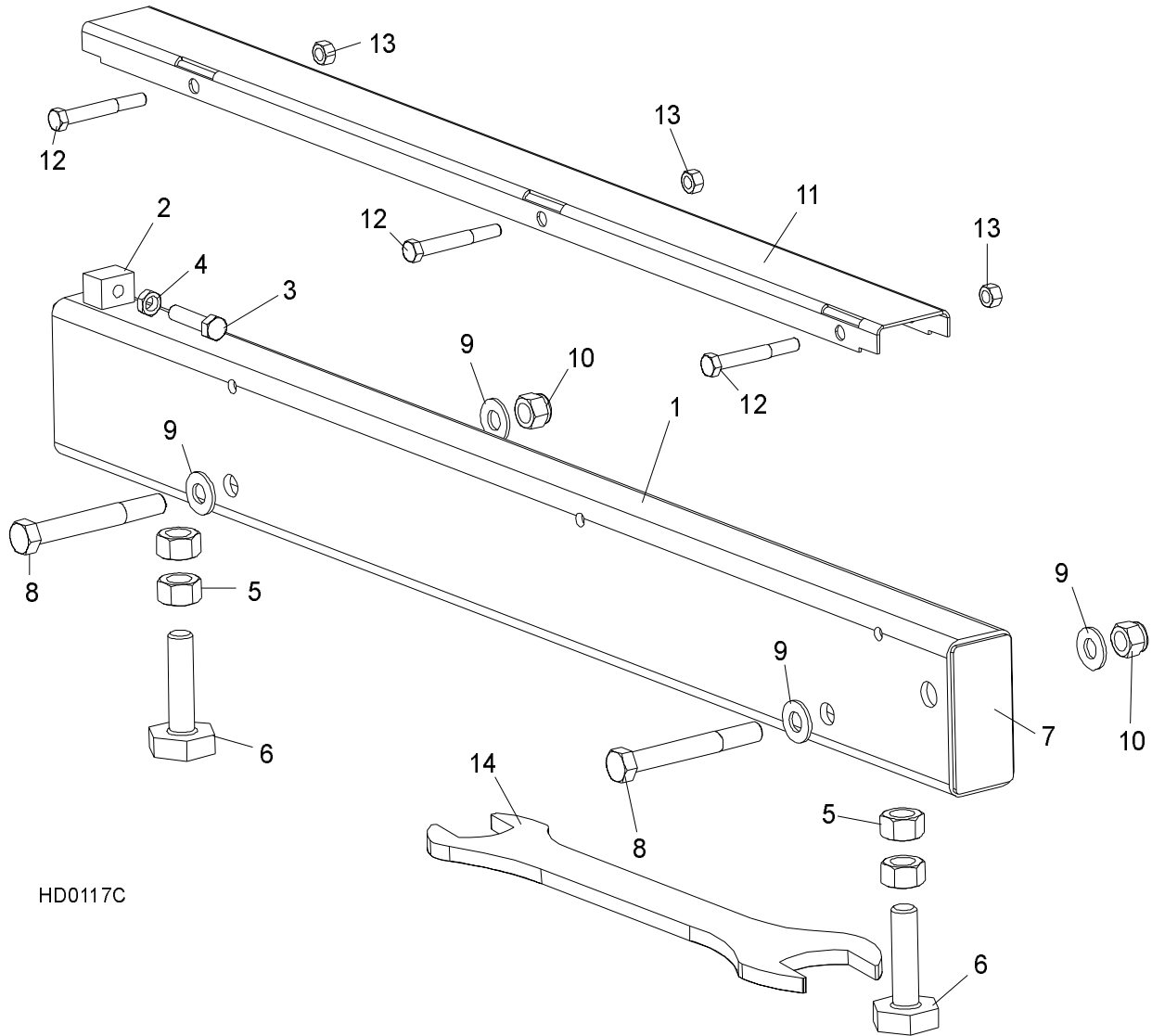

REF	DESCRIPTION (◆ Indicates Parts Available in Assemblies Only)	PART #	QTY.	
	BED RAIL ASSEMBLY, REAR MIDDLE PAINTED	015757	1	
1	Bed Rail Tube, Short	014640	1	◆
2	Block, Log Stop w/Threaded Hole	014639	1	◆
3	Bolt, 3/8-16 x 1 1/2 Full Thread Hex Head	F05007-17	1	
4	Nut, 3/8-16 Hex Jam	F05010-29	1	
	Bolt Assembly, Bed Rail	086809	2	◆
5	Nut, 5/8-11 Hex	F05010-54	2	
6	Bolt, Bed Rail Adjustment	S13006	2	
7	Plate, Bed Rail End Cap	S04058	2	◆
8	BOLT, M12 X 100-8.8 HEX HEAD	F81004-3	2	
9	WASHER, 13 FLAT	F81056-1	4	

Bed Frame Assembly
Bed Rail Assembly, Rear Middle

8

10	NUT, M12-8 NYLON LOCK	F81034-2	2	
	COVER ASSEMBLY, STAINLESS STEEL BED RAIL (LONG)	A09956	1	
11	Cover, Stainless Steel Bed Rail	S09944	1	◆
12	Bolt, 5/16-18 X 2 1/2" Hex Head	F05006-10	3	
13	Nut, 5/16-18 Hex Lock	F05010-6	3	
14	WRENCH, BED RAIL ADJUSTMENT	015970	1	

8 Bed Frame Assembly

Leg, Stationary

8.4 Leg, Stationary

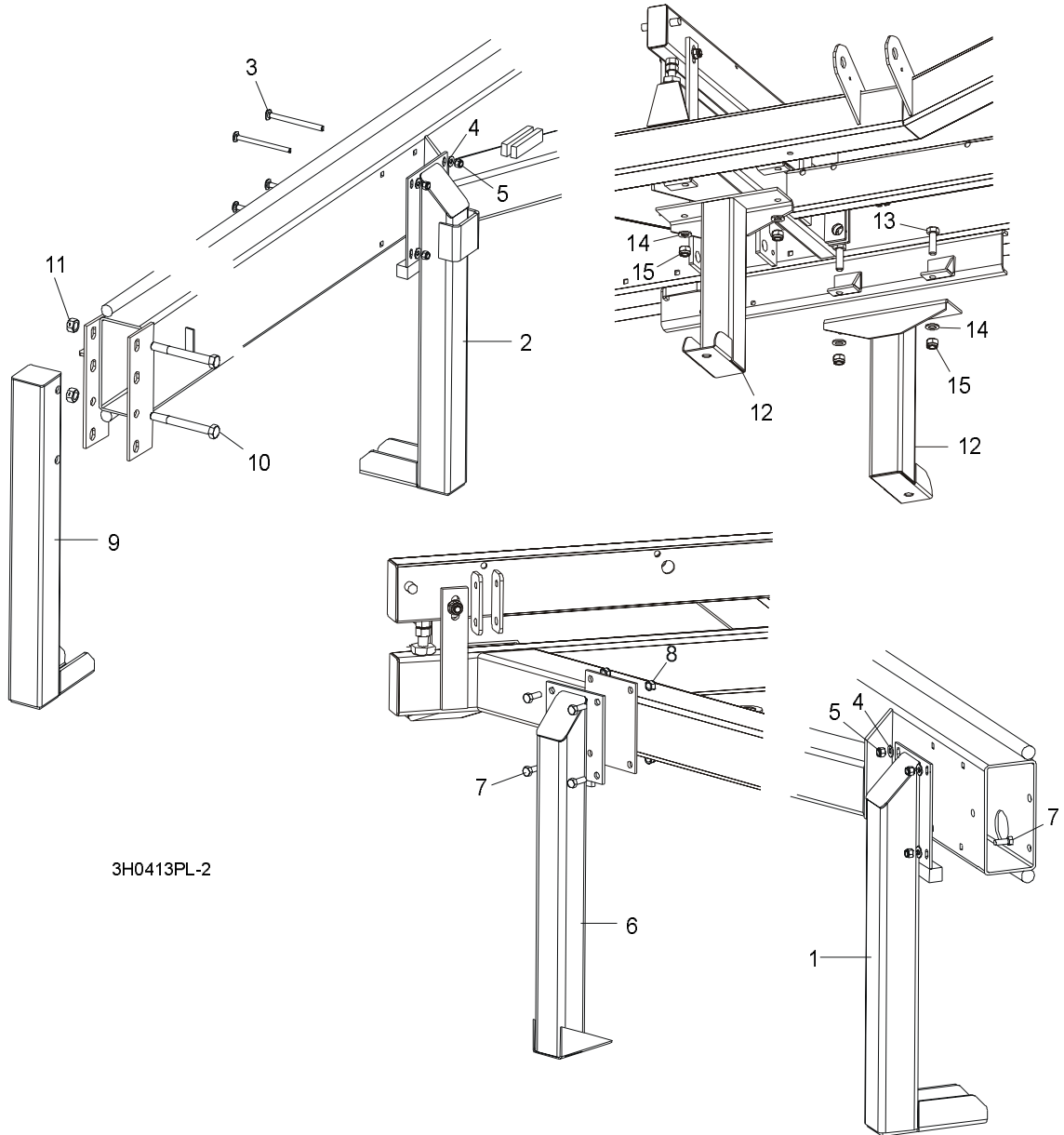

REF	DESCRIPTION (◆ Indicates Parts Available In Assemblies Only)	PART #	QTY.
1	LEG, LONG RIGHT STATIONARY (1 REQ'D FOR LT30HD; 3 REQ'D FOR LT40HD)	087451-1	1/3
2	LEG, LONG STATIONARY W/BOARD RETURN TABLE BRACKET	087449-1	1
3	BOLT, M10 X 120-8.8 CARRIAGE HEAD	F81003-33	8/12
4	WASHER, 10.5 FLAT	F81055-1	8/16
5	NUT, M10-8-B HEX NYLON LOCK	F81033-1	8/16
6	LEG, SHORT LEFT STATIONARY	087450-1	2
7	BOLT, M10 X 25-8.8 HEX HEAD	F81003-11	12
8	NUT, M10-8-B HEX NYLON LOCK	F81033-1	12
9	LEG, FRONT STATIONARY	087452-1	1

10	BOLT, M16 X 140-8.8 HEX HEAD GRADE 5	F81006-4	2	
11	NUT, M16-8 HEX LOCK	F81036-2	2	
12	LEG, MIDDLE STATIONARY	087093-1	2	
13	BOLT, M16 X 50-8.8 HEX HEAD	F81006-7	4	
14	WASHER, 17 FLAT	F81058-1	4	
15	NUT, M16 NYLON LOCK	F81036-2	4	

8 Bed Frame Assembly

Board Return Table Assembly

8.5 Board Return Table Assembly

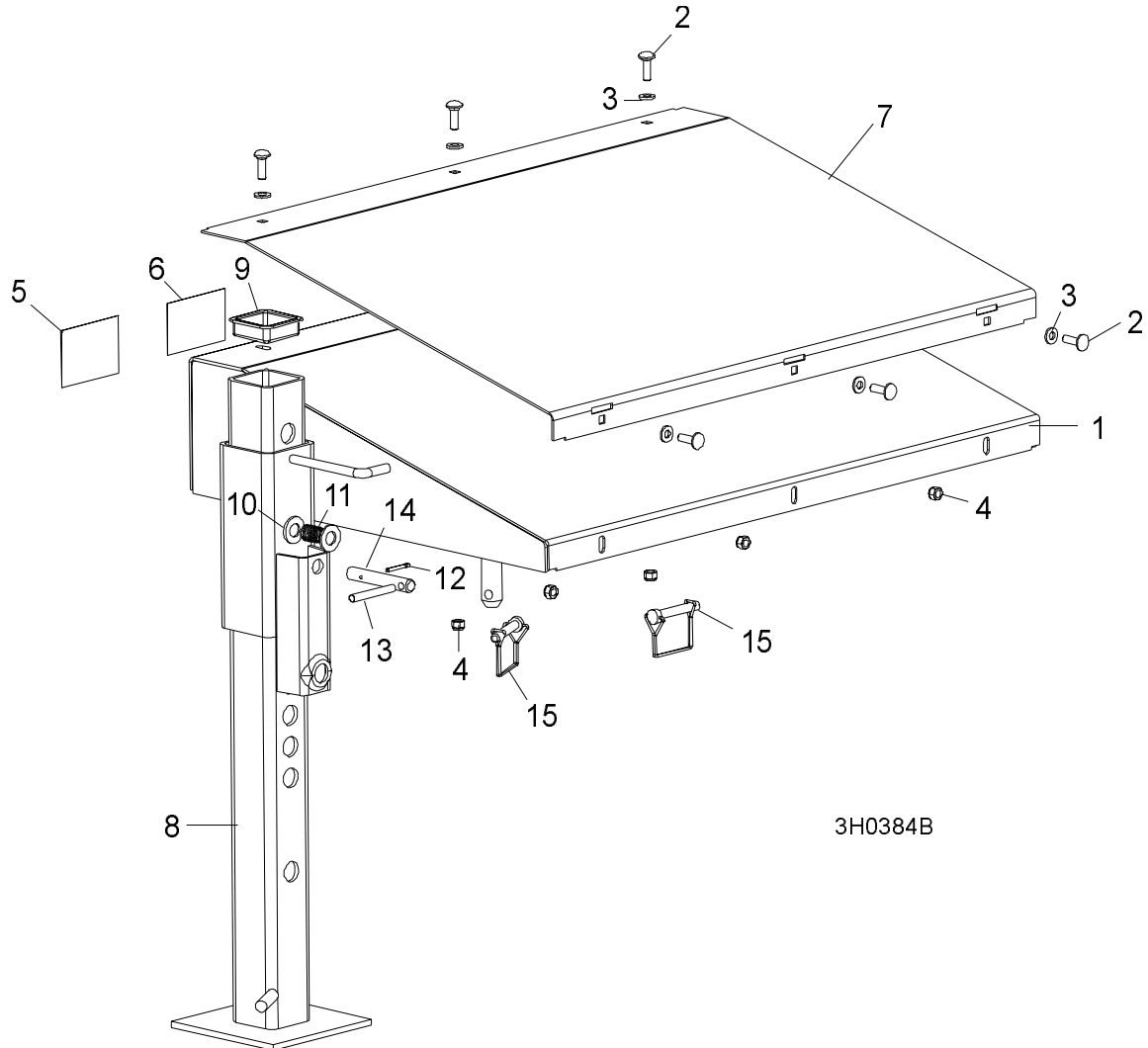

3H0384B

	DESCRIPTION (◆ Indicates Parts Available In Assemblies Only)	PART #	QTY.	
	TABLE ASSEMBLY, BOARD RETURN	015792	1	
1	Table Weldment, Board Return	015790	1	◆
2	Bolt, 5/16-18 x 1" Carriage Head	F81002-1	6	
3	Washer, 5/16" SAE Flat	F81032-2	6	
4	Nut, 5/16-18 Nylon Lock	F81054-1	6	
5	Decal, Board Return Danger	015365	1	
6	Decal, Board Return Table Warning	016077	1	
7	Plate, Return Table Stainless Steel	015791	1	
8	Leg Weldment, Painted Outrigger	W07537	1	
9	Cap, Outrigger Leg	P09926	1	
10	Washer, 9/16" SAE Flat	F81057-2	2	
11	Spring, .72 X 1.5 X .967" Diameter Stainless Steel Compression	P04282	1	
12	Pin, 1/8" X 1" Cotter	F05012-1	1	

	Pin, Outrigger Pull Painted	S12260-0	1	
13	Pin, 5/16 x 2 1/2" Roll	F05012-47	1	
14	Pin, Outrigger Pull	S12260-0	1	
15	Pin, 3/8 X 2 1/4" Square Wire Lock	014151	2	

8 Bed Frame Assembly

Pivot Bed Rail Assembly

8.6 Pivot Bed Rail Assembly

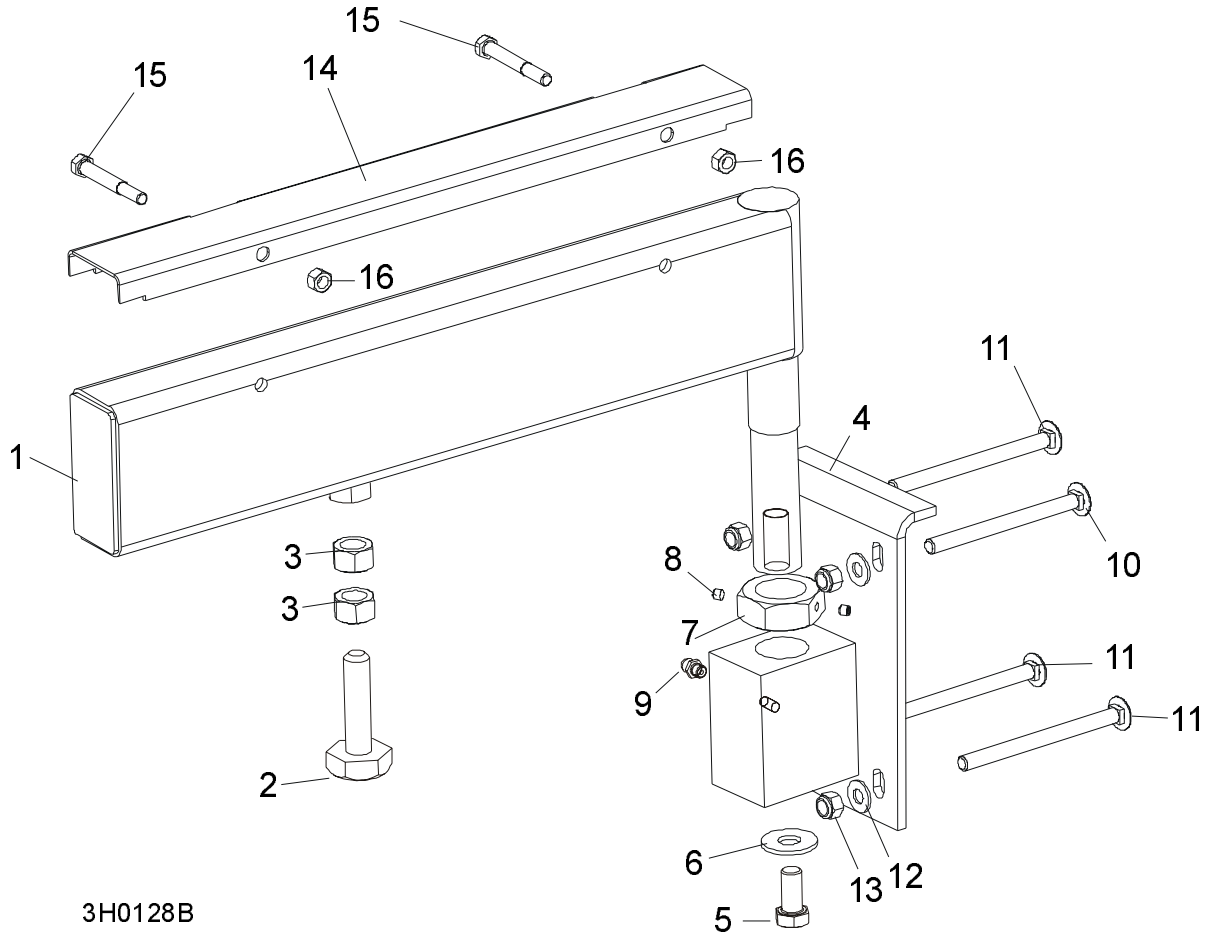

3H0128B

REF	DESCRIPTION (◆ Indicates Parts Available In Assemblies Only)	PART #	QTY.
	PIVOT BED RAIL ASSEMBLY (LT30HD)	087829	2
	PIVOT BED RAIL ASSEMBLY (LT40HD)	087855	2
1	Pivot Bed Rail Weldment (LT30HD)	087852-1	1
	Pivot Bed Rail Weldment (LT40HD)	087848-1	1
	Bolt Assembly, Bed Rail Adjustment		1
2	Bolt, Bed Rail Adjustment	086809	1
3	Nut, 5/8-11 Hex	F81036-1	2
4	Bracket, Pivot Rail Mounting	087841-1	1
5	Bolt, 1/2-13 x 1" Hex Head Grade 2	F81004-31	1
6	Washer, 15 Flat	F05011-52	1
7	Nut, Pivot Rail Adjustment (LT30HD) Nut, Pivot Rail Adjustment (LT40HD)	F81036-1 F81039-2	1
8	Screw, 1/4-28 x 1/4" Brass Tip Set	F05005-42	2
9	Fitting, 3/16" Grease	086280	1
10	BOLT, 3M10 X 120-8.8 CARRIAGE HEAD	F81003-14	2
11	BOLT, 3/8-16 X 5" CARRIAGE HEAD	F05007-113	6

12	WASHER, 10.5 FLAT	F81055-1	8	
13	NUT, M16-8 NYLON LOCK	F81036-2	8	
	COVER KIT, PIVOT RAIL STAINLESS STEEL (LT30HD)	015926	2	
	COVER KIT, PIVOT RAIL STAINLESS STEEL (LT40HD)	N/A	2	
14	Cover, Stainless Steel Pivot Bed Rail (LT30HD)	012994	1	
	Cover, Stainless Steel Pivot Bed Rail (LT40HD)	S13012	1	
15	Bolt, 5/16-18 X 2 1/2" Hex Head	F05006-10	2	
16	Nut, 5/16-18 Hex Lock	F05010-6	2	
	WRENCH, BED RAIL ADJUSTMENT (See Section 8.3)	015970	1	

8.7 Log Side Support Assembly (Manual)

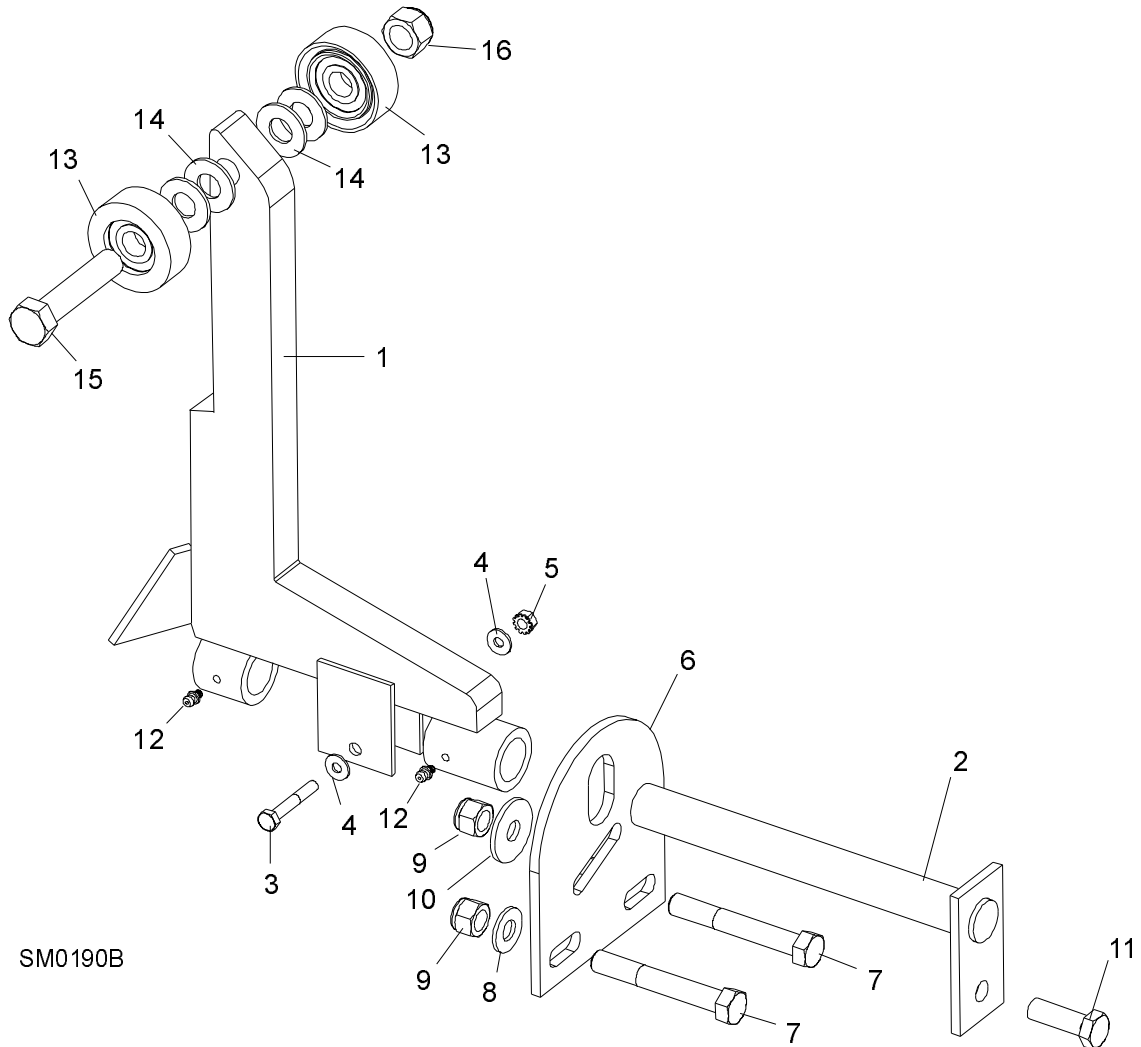

[See Section 9.6](#) for hydraulic side supports...

REF	DESCRIPTION (◆ Indicates Parts Available in Assemblies Only)	PART #	QTY.
1	SUPPORT, LOG SIDE	085538	2
	MOUNTING KIT, LOG SIDE SUPPORT	K09440	2
2	Pin, Log Side Support Pivot	W09238-1	1
3	Bolt, 1/4-20 X 1 1/2" Hex Head Grade 5	F05005-4	1
4	Washer, 7.4 Flat	F81056-11	2
5	Nut, 1/4-20 Self Locking	F05010-9	1
6	Plate, Log Side Support End	S09148	1
7	Bolt, M12 x 90-8.8 Hex Head	F81004-2	2
8	Washer, 13 Flat	F81056-1	2
9	Nut, M12-8 Hex Nylon Lock	F81034-2	3
10	Washer, .5" x 1.63" x 11" Ga.	086184	1

11	Bolt, M12 x 35-8.8 Hex Head	F81004-11	1	
12	FITTING, 3/16" GREASE	P04107	2	
	ROLLER KIT, SIDE SUPPORT (OPTIONAL)	015109	4	
13	Roller Assembly, Side Support	015014-1	2	
14	Washer, 17 Flat	F81058-1	4	
15	Bolt, 5/8-11 x 3" Hex Head Grade 5	F05009-37	1	
16	Nut, 5/8-11 Nylon Lock	F05010-34	1	
	Instruction Sheet, Side Support Roller	015109-526	1	

8 Bed Frame Assembly

Tie Down Chain Assembly

8.8 Tie Down Chain Assembly

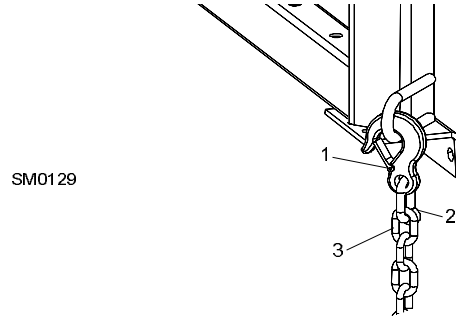

REF	DESCRIPTION (◆ Indicates Parts Available In Assemblies Only)	PART #	QTY.	
	CHAIN ASSEMBLY, TIE DOWN	A04376	1	
1	Hook, 5/8" Safety Chain	P12075	1	◆
2	Cold Shut, 3/8" Plain	P04772-2	1	◆
3	Chain, N-10 x 35 Unplated	R80558	.28 m	◆

8.9 Saw Head Rest Pin Assembly

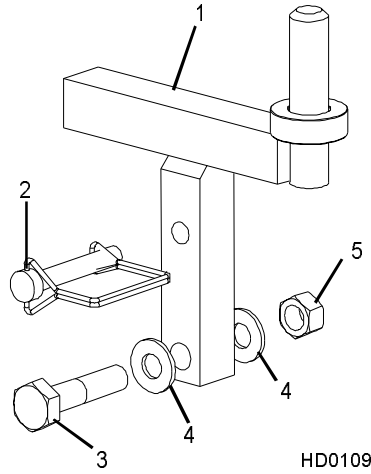

HD0109

REF	DESCRIPTION (◆ Indicates Parts Available In Assemblies Only)	PART #	QTY.
1	PIN, SAW HEAD REST	085949	1
2	PIN, 3/8" X 2 1/4" SNAP RETAINER	014151	1
3	BOLT, M12 X 60-8.8 HEX HEAD GRADE 5	F81004-5	1
4	WASHER, 13 SAE FLAT	F81056-1	2
5	NUT, 1/2-13 HEX LOCK	F05010-3	1

8 Bed Frame Assembly

Bed Frame Decals

8.10 Bed Frame Decals

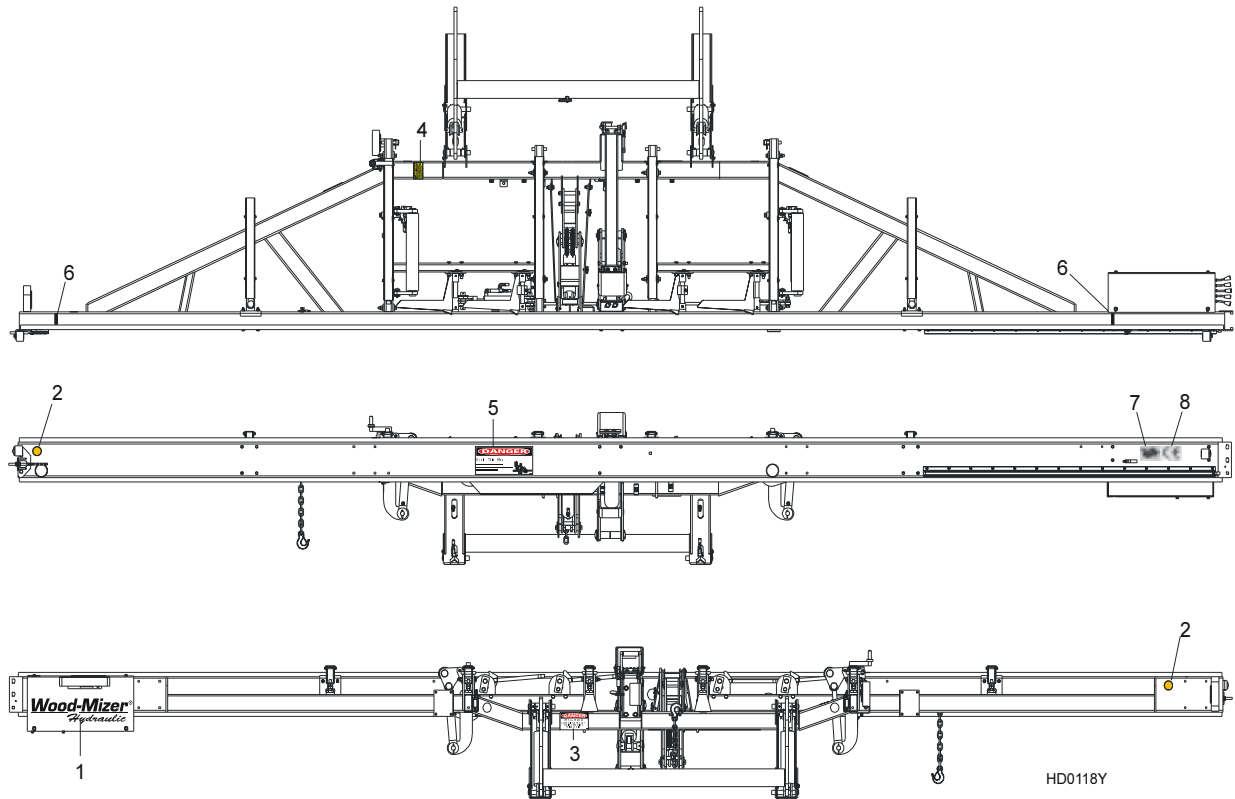

REF	DESCRIPTION (◆ Indicates Parts Available In Assemblies Only)	PART #	QTY.	
1	DECAL, WOOD-MIZER SUPER HYDRAULIC LOGO	014168	1	
2	DECAL, AMBER REFLECTIVE 2" ROUND	P07453	2	
3	DECAL, KEEP AWAY DANGER	S09851	1	
4	DECAL, PINCH POINT DANGER	P10287	1	
5	DECAL, SAW HEAD REST CAUTION	S12581	1	
6	DECAL, LOG LIMIT STRIPE	S12051	2	
7	DECAL, GS SAFETY CERTIFICATION, SMALL	P85072	1	
8	DECAL, CE CERTIFIED SAWMILL, SMALL	P85070	1	

SECTION 9 HYDRAULIC SYSTEM

9.1 Hydraulic Hoses, LT30HD/40HD Super

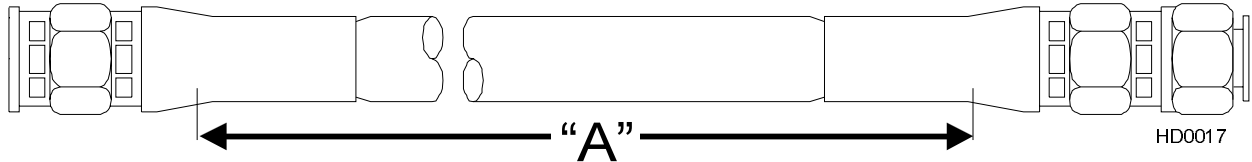

COLOR	LENGTH "A"	DESCRIPTION (◆ Indicates Parts Available In Assemblies Only)	PART #	QTY.
None	10"	3/8" HYDRAULIC PUMP TO VALVE	087774	1
Plain	27"	3/8" LOG TURNER CYLINDER BASE	014796	1
Orange	21"	3/8" LOG TURNER CYLINDER TOP	087775	1
Yellow	105"	1/4" FRONT TOE BOARD TOP (LT30HD SUPER)	087790	1
	127"	1/4" FRONT TOE BOARD TOP (LT40HD SUPER)	087776	1
Gray	105"	1/4" FRONT TOE BOARD BASE (LT30HD SUPER)	087790	1
	127"	1/4" FRONT TOE BOARD BASE (LT40HD SUPER)	087776	1
Plain	166"	3/8" SIDE SUPPORT CYLINDER TOP (LT30HD SUPER)	087791	1
	188"	3/8" SIDE SUPPORT CYLINDER TOP (LT40HD SUPER)	087777	1
Pink	168"	3/8" SIDE SUPPORT CYLINDER BASE (LT30HD SUPER)	087791	1
	188"	3/8" SIDE SUPPORT CYLINDER BASE (LT40HD SUPER)	087777	1
White	145"	3/8" CLAMP CYLINDER TOP (LT30HD SUPER)	087792	1
	157"	3/8" CLAMP CYLINDER TOP (LT40HD SUPER)	087778	1
Dark Orange	129"	3/8" CLAMP CYLINDER BASE (LT30HD SUPER)	087793	1
	151"	3/8" CLAMP CYLINDER BASE (LT40HD SUPER)	087779	1
Purple	204"	1/4" REAR TOE BOARD TOP (LT30HD SUPER)	087794	1
	226"	1/4" REAR TOE BOARD TOP (LT40HD SUPER)	087780	1
Black	204"	1/4" REAR TOE BOARD BASE (LT30HD SUPER)	087794	1
	226"	1/4" REAR TOE BOARD BASE (LT40HD SUPER)	087780	1
Green	62"	3/8" LOADING ARM BRANCH TOP	014797	2
Yellow	63"	3/8" LOADING ARM BRANCH BASE	014798	2
Blue	171"	3/8" LOADING ARM CYLINDER TOP (LT30HD SUPER)	087795	1
	193"	3/8" LOADING ARM CYLINDER TOP (LT40HD SUPER)	087781	1
Red	171"	3/8" LOADING ARM CYLINDER BOTTOM (LT30HD SUPER)	087795	1
	193"	3/8" LOADING ARM CYLINDER BOTTOM (LT40HD SUPER)	087781	1
Green	180"	1/4" CLAMP UP (LT30HD SUPER)	087796	1
	202"	1/4" CLAMP UP (LT40HD SUPER)	087789	1
Yellow	180"	1/4" CLAMP DOWN (LT30HD SUPER)	087796	1
	202"	1/4" CLAMP DOWN (LT40HD SUPER)	087789	1

9.2 Hydraulic Control Box, LT30AHD/LT40AHD Super

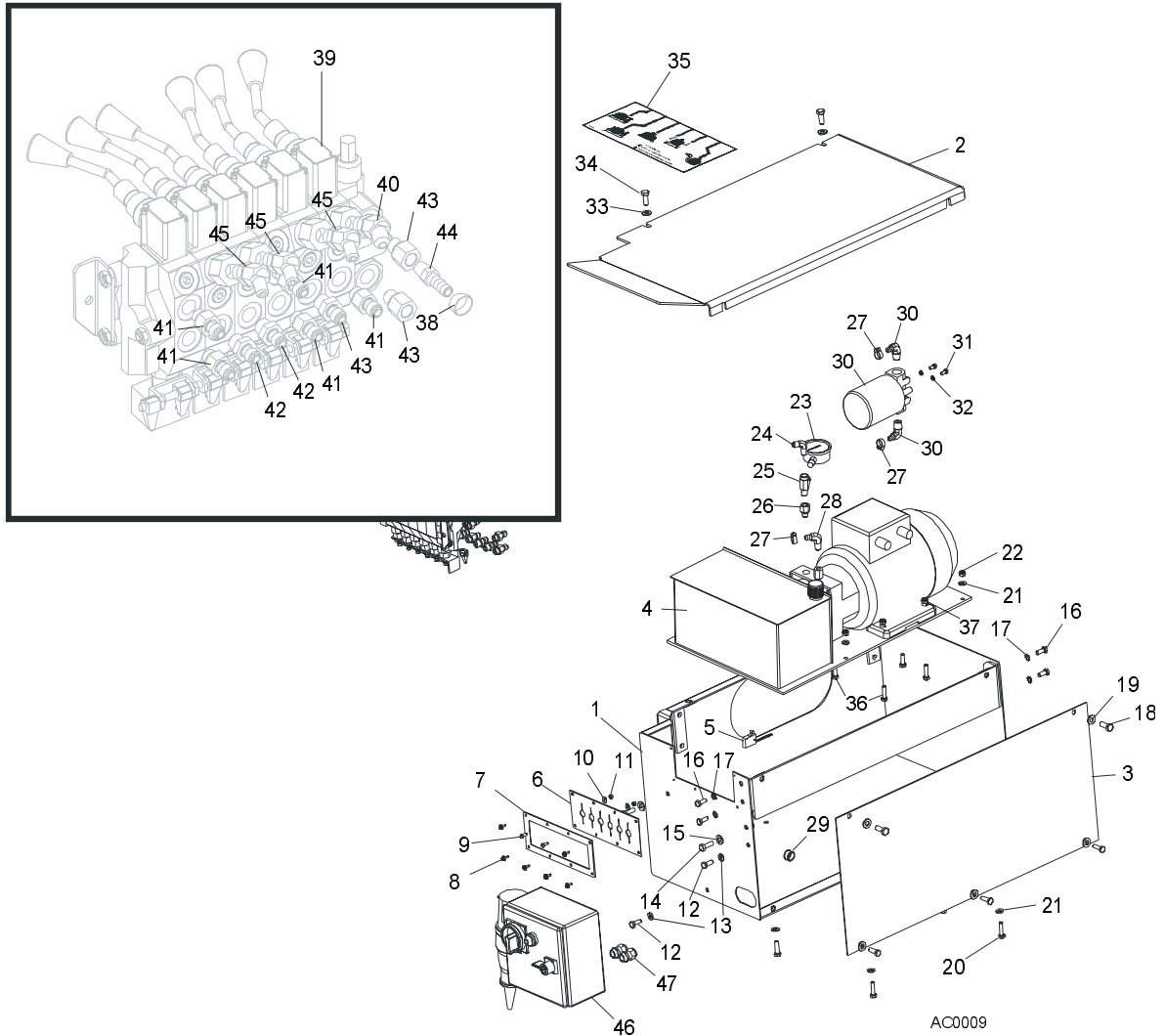

REF	DESCRIPTION (◆ Indicates Parts Available In Assemblies Only)	PART #	QTY.	
	BOX, AC SUPER HYDRAULIC (EA20, EA25)	086791	1	
1	BOX WELDMENT, SUPER HYDRAULIC PUMP HOUSING	086480-1	1	
2	COVER, AC HYDRAULIC PUMP HOUSING TOP	086485-1	1	
3	COVER, AC HYDRAULIC PUMP HOUSING SIDE	086484-1	1	
4	FEEDER, 4 KW 14.5 L/MIN. SUPER AC HYDRAULIC WITH PUMP	086789	1	
5	Microswitch, Hydraulic Valve	014765	1	
6	SEAL, RUBBER VALVE HANDLE	015079	1	
7	PLATE, VALVE	086519-1	1	
8	SCREW, #10 X 1/2 SLOTTED HEX SELF-TAPPING	F05015-7	6	
9	BOLT, M5X12-5.8	F81000-5	2	
10	WASHER, 5.5	F81052-3	2	
11	NUT, M5-8	F81030-1	2	

12	BOLT, M8 X 20-8.8-B HEX HEAD	F81002-4	2	
13	WASHER, 8.4 FLAT	F81054-1	2	
14	BOLT, 3/8-16X1 GR8 HEX HEAD	F05007-7	2	
15	WASHER, 10.5 FLAT	F81055-1	2	
16	BOLT, M8 X 20-8.8-B HEX HEAD	F81002-4	4	
17	WASHER, 8.4 EXTERNAL STAR LOCK	F81054-3	4	
18	BOLT, M10 X 25-8.8 HEX HEAD	F81003-11	4	
19	WASHER, 10.5 FLAT	F81055-1	4	
20	BOLT, M8 X 25-8.8-B HEX HEAD	F81002-5	4	
21	WASHER, 8.4 FLAT	F81054-1	4	
22	NUT, M8-8-B	F81032-2	4	
23	GAUGE, 3000 PSI OIL PRESSURE	P10052	1	
24	FITTING, ELBOW	015491	1	
25	FITTING	P09141	1	
26	FITTING #6	014686	1	
27	CLAMP, 11/16 HOSE	P12739	3	
28	FITTING, 3/8" NPT - 3/8" ELBOW	P12708	1	
29	BRANCH-JOINT, HYDRAULIC WITH FILTER	P22683	1	
30	FITTING, 1/2" NPT - 3/8" ELBOW	P12707	2	
31	BOLT, 1/4-20 X 1/2"	F05005-15	2	
32	WASHER, 6.1 SPLIT LOCK	F81053-3	2	
33	WASHER, 10.5 FLAT	F81055-1	2	
34	BOLT, M10 X 25-8.8-FE/ZN5 HEX HEAD	F81003-11	2	
35	DECAL, 1997 SUPER HYDRAULIC CONTROL BOX	015364	1	
36	BOLT, M8 X 30-8.8-B HEX HEAD	F81002-7	4	
37	NUT, M8-8-B	F81032-2	4	
38	CLAMP, 11/16" HOSE	P12739	10	
39	VALVE, HYDRAULIC 6 SECTION	086589	1	
	SWITCH, HYDRAULIC VALVE ELECTRIC	024198	1	
40	FITTING, #6 SAE - 3/8" JIC 45° ELBOW	015489	1	
41	FITTING, 3/8" O-RING - 3/8" JIC	014687	5	
42	FITTING, 3/8" O-RING - 1/4" JIC	P26284	3	
43	FITTING, #6 SAE MALE - 1/4" NPT FEMALE	014686	2	
44	FITTING, 1/4" NPT X 3/8" HOSE BARB	014685	1	
45	FITTING, #6 SAE - 1/4" JIC 45° ELBOW	015488	3	
46	BOX, AC HYDRAULIC (SUPER ONLY)	086820	1	
47	GLAND, WIRE (SUPER ONLY)	085388	2	

9.3 Hydraulic Power Supply Strip

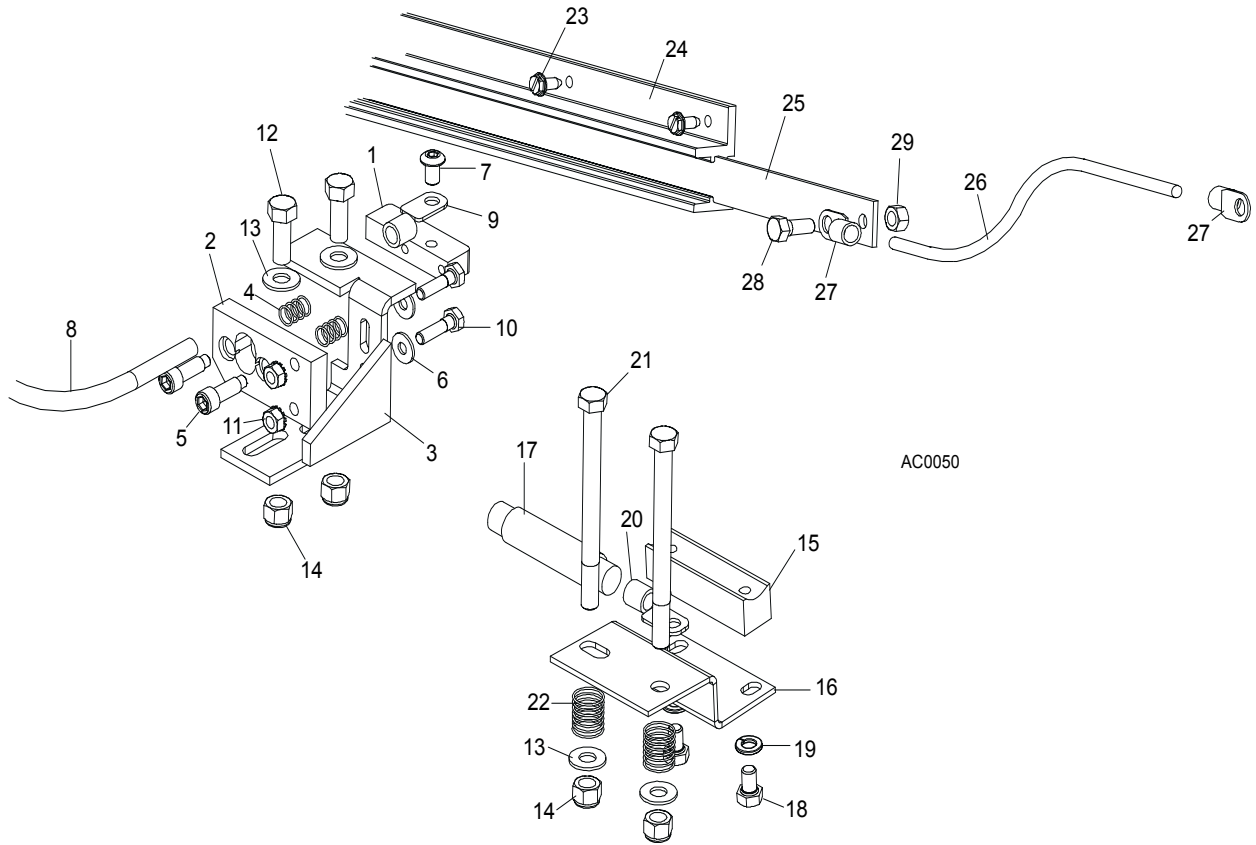

REF	DESCRIPTION (◆ Indicates Parts Available In Assemblies Only)	PART #	QTY.	
	CONTACT ASSEMBLY, HYDRAULIC POWER SUPPLY (POSITIVE)	086625	1	
1	Contact, Hydraulic Power Supply (Positive)	015253	1	
2	Insulator, Positive Contact	S10072	1	
3	Bracket, Positive Contact Mounting	086380-1	1	
4	Spring, Positive Contact	P10077	2	
5	Bolt, 5/16" X 3/4" Shoulder (1/4-20 Thread)	F05006-44	2	
6	Washer, 8.4 Flat	F81054-1	2	
7	Bolt, 5/16-18 x 1/2" Socket Button Head	F05006-20	1	
8	Cable, LGY 1mm2 Red	R80583-2	1 m	◆
9	Terminal, KO 1/10	F81064-11	2	
10	Bolt, 1/4-20 X 1" Hex Head Grade 2	F05005-38	2	
11	Nut, 1/4-20 Hex Self-Locking	F05010-9	2	
12	Bolt, 3/8-16 X 1" Hex Head Grade 5	F05007-87	2	
13	Washer, 10.5 Flat	F81055-1	4	
14	Nut, 3/8-16 Hex Nylon Lock	F05010-10	4	
	CONTACT ASSEMBLY, HYDRAULIC POWER SUPPLY (GROUND)	086624	1	
15	Contact, Hydraulic Power Supply (Ground)	015264	1	
16	Bracket, Ground Contact Mounting	090254-1	1	
17	Cable, LGY 1mm2 Black	R80583-21	.21m	◆

18	Bolt, 5/16-18 X 1/2" Hex Head Grade 5	F05006-15	2	
19	Washer, 8.2 Split Lock	F81054-4	2	
20	Terminal, KO 1/10	F81064-11	1	
21	Bolt, 3/8-16 X 4 1/2" Hex Head Grade 2	F05007-35	2	
22	Spring, Ground Contact	P04282	2	
23	Screw, 1/4-20 X 1/2" Slotted Hex Head	F05015-1	14	
	STRIP ASSEMBLY, HYDRAULIC POWER SUPPLY	086653	1	
24	Housing, Contact Strip	086685	1	
25	Strip, Contact	086686	1	◆
26	Cable, #2 Weld	R80583-21	19m	◆
27	Terminal, KO 1/10	F81064-11	4	
28	Bolt, 5/16-18 X 3/4" Hex Head Black Nylon	F05006-45	1	
29	Nut, 5/16-18 Hex Black Nylon	F05010-86	1	

9.4 Hydraulic Log Loader

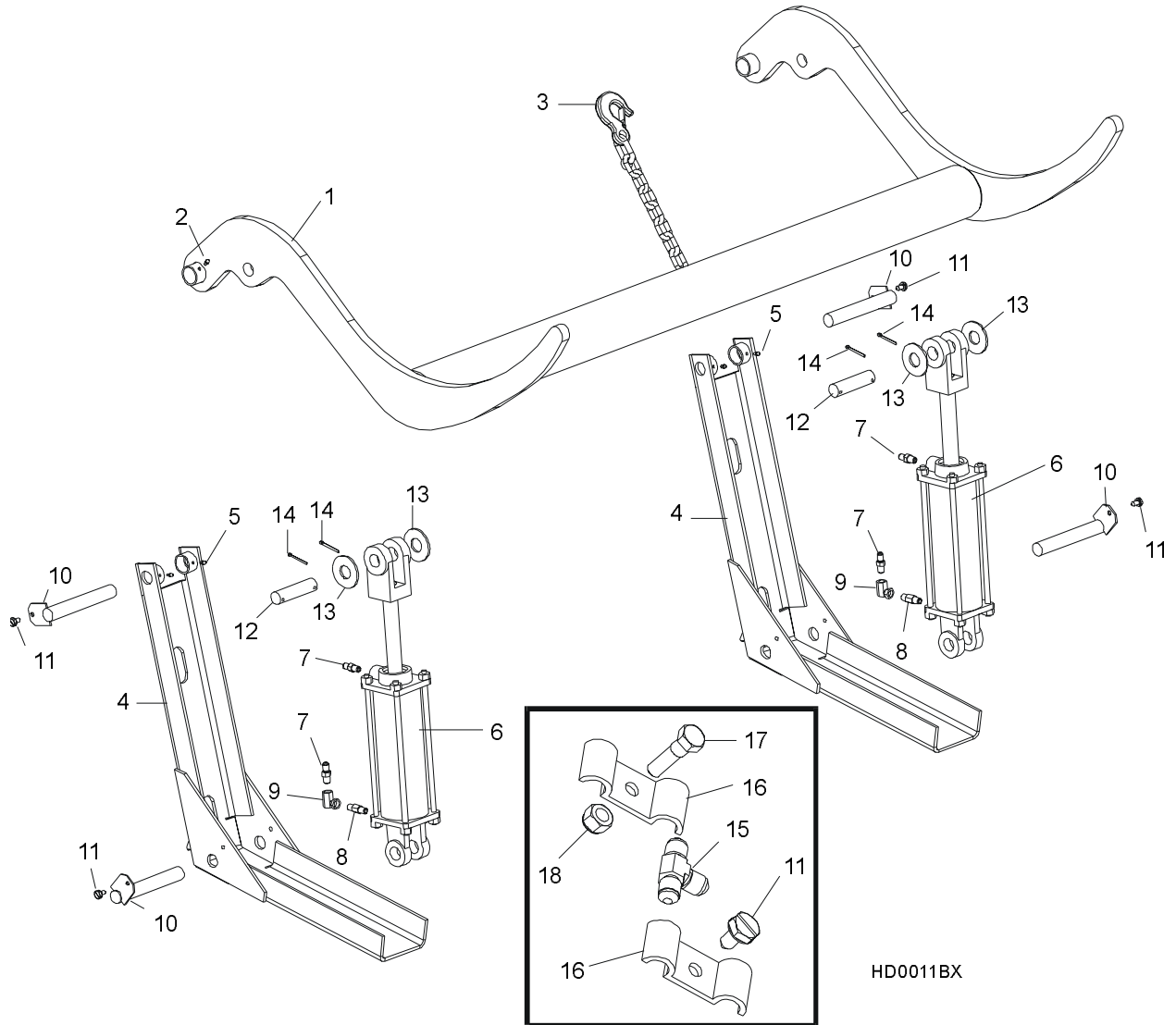

REF	DESCRIPTION (◆ Indicates Parts Available in Assemblies Only)	PART #	QTY.
	LOADER KIT, HYDRAULIC LOG	086534	1
1	Arm, Hydraulic Log Loading	086535-1	1
2	Fitting, 3/16" Grease	P04107	2
3	Chain, Hydraulic Log Loader Safety	A04376	1
4	Channel, Hydraulic Log Loading Foot	W09444	2
5	Fitting, 3/16" Grease	P04107	2
	Cylinder Assembly, Super Hydraulic Log Loading Arm	015562	2 ◆
6	Cylinder hydr.CJ-S95-16-70/32/203	088680	1
	Seal Kit, 8" x 3" Hydraulic Cylinder	P12956	1
7	Fitting, 1/4 NPT - 3/8" JIC Straight	015560	2
	Fitting Kit, 1/4NPT 4.0GPM Velocity Fuse	015832	1

8	Fitting, 1/4NPT 4.0GPM Velocity Fuse	015750	2	◆
	Instruction Sheet, Velocity Fuse Replacement	015832-255	1	
9	Fitting, 0455x4x4 90° Swivel Elbow	P12199	1	
10	Pin, Loading Arm Mount	W09446-1	4	
11	Screw, 5/16-18 X 3/4" Self Tapping	F05015-30	8	
12	Pin, Loading Arm Cylinder Mount	086979-1	2	
13	Washer, 28 Flat	F81061-1	4	
14	Pin, 3/16" X 1 1/2" Cotter	F05012-23	4	
15	Fitting, 3/8" JIC Union 'T'	015485	1	
16	Clamp, 3/8" Hydraulic Hose	016041	6	
17	Bolt, 5/16-18 X 1" Hex Head Grade 2	F05006-1	2	
18	Nut, 5/16-18 Hex Nylon Lock	F05010-58	2	

9.5 Hydraulic Log Turner

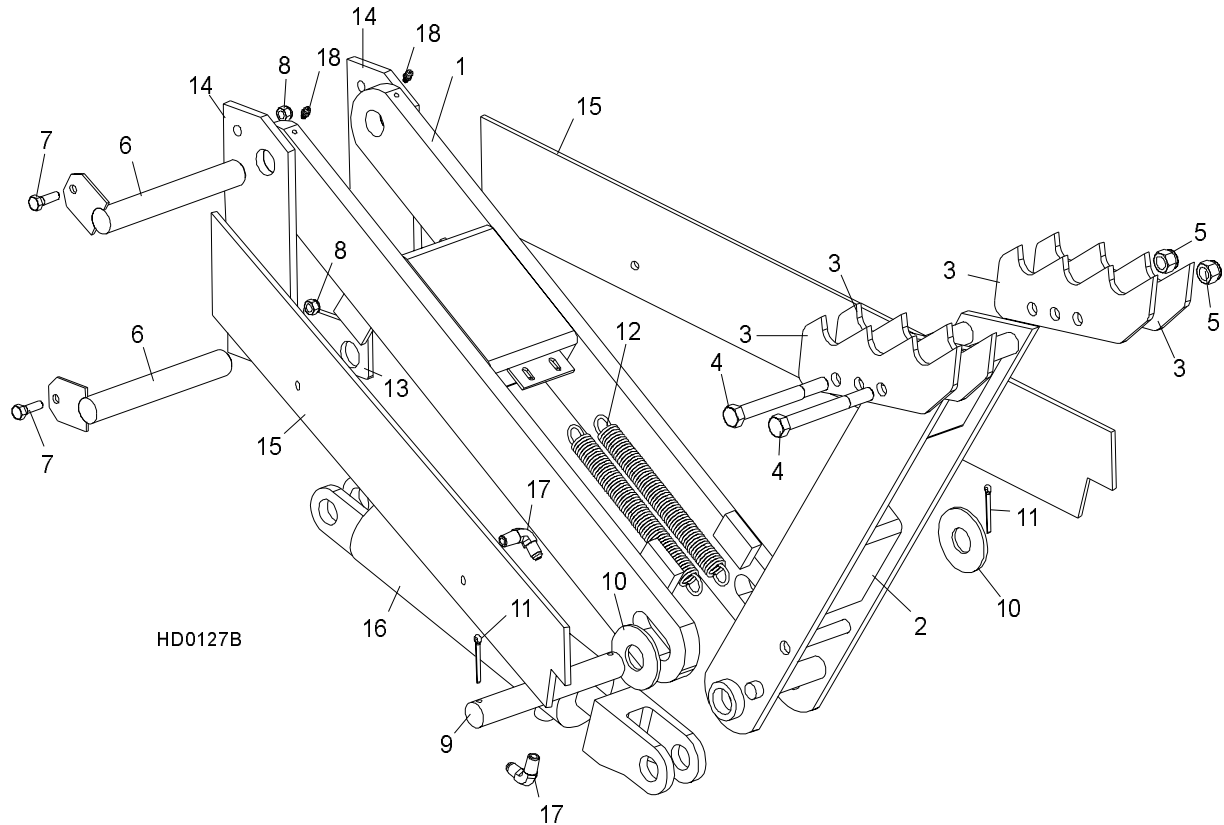

REF	DESCRIPTION (◆ Indicates Parts Available in Assemblies Only)	PART #	QTY.
1	ARM, HYDRAULIC LOG TURNER LINK	015231	1
2	ARM, HYDRAULIC LOG TURNER PAINTED	015233	1
3	CLAW, HYDRAULIC LOG TURNER	014675	4
4	BOLT, M12 X 25-8.8 HEX HEAD	F81004-34	2
5	NUT, M12-8 HEX LOCK	F81034-2	2
6	PIN, LOG TURNER MOUNT	015085-1	2
7	BOLT, 5/16-18 X 1" HEX HEAD GRADE 2	F05006-1	2
8	NUT, 5/16-18 HEX LOCK	F05010-6	2
9	PIN, LOG TURNER PIVOT	S09246	1
10	WASHER, 28 FLAT	F81061-1	2
11	PIN, 3/16" X 1 1/2" COTTER	F05012-23	2
12	SPRING, HYDRAULIC LOG TURNER	015718	2
13	PLATE, LOG TURNER CYLINDER MOUNT	S09155	1
14	PLATE, LOG TURNER MOUNT	085884	2
15	PLATE, LOG TURNER BRACE	S09605-0	2
	CYLINDER ASSEMBLY, SUPER HYDRAULIC LOG TURNER	015563	1
16	Cylinder hydr.CJ-S305-16-63/28/203	088679	1
	Seal Kit, 8" x 2 1/2" Hydraulic Cylinder	P12955	1
17	Fitting, 1/4" NPT - 3/8 JIC Elbow	015491	2
18	FITTING, 3/16" GREASE	P04107	2

9.6 Hydraulic Log Side Supports

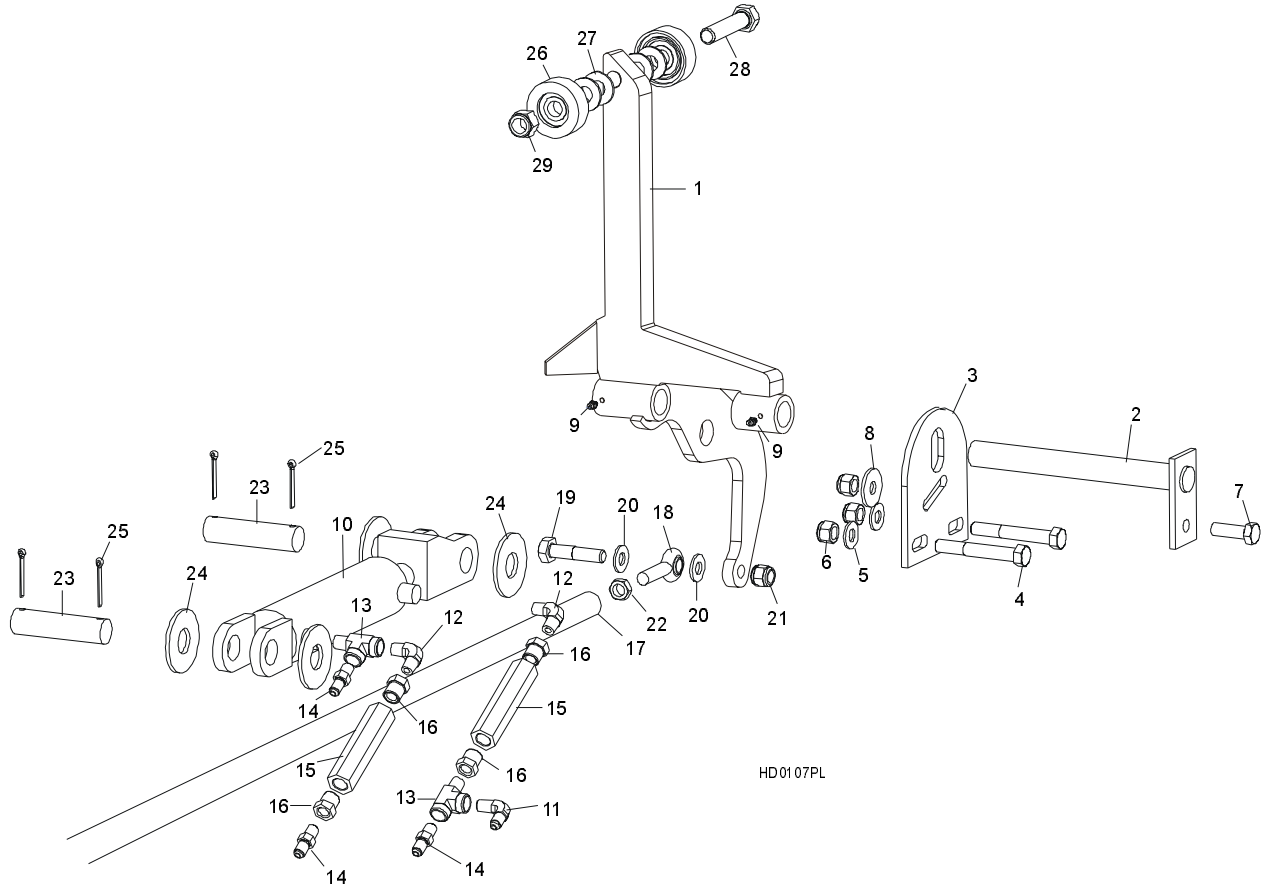

REF	DESCRIPTION (◆ Indicates Parts Available in Assemblies Only)	PART #	QTY.	
1	SUPPORT, HYDRAULIC LOG SIDE	085578	2	
	MOUNTING KIT, HYDRAULIC LOG SIDE SUPPORT	K09344	2	
2	Pin, Log Side Support Pivot	W09238	1	
3	Plate, Log Side Support End	S09148	1	
4	Bolt, M12 x 40-8.8 Hex Head	F81004-4	2	
5	Washer, 13 Flat	F81056-1	2	
6	Nut, M12-8 Hex Nylon Lock	F81034-2	3	
7	Bolt, M12 x 40-8.8 Hex Head Grade 5	F81004-4	1	
8	Washer, 45/13	086184	1	
9	FITTING, 3/16" GREASE	P04107	4	
	CYLINDER ASSEMBLY, SUPER HYDRAULIC LOG SIDE SUPPORT	015561	1	
10	Cylinder hydr. C-J-S270-16-50/28/152	088678	1	◆
	Seal Kit, 6" x 2" Hydraulic Cylinder	P12954	1	
11	Fitting, 3/8" JIC - 1/4" NPT Elbow	015491	2	
12	Fitting, C3529x4 90° Pipe	P09140	2	
13	Fitting, C3759x4 Male 'T'	P09141	2	
14	Fitting, 3/8" JIC - 1/4" NPT	015560	2	

15	Valve, Hydraulic Sequence	015484	2	
16	Fitting, 3/8" NPT - 1/4" NPT Reducer	015490	4	
17	ROD, HYDRAULIC SIDE SUPPORT LINK	087037-1	1	
18	END, RIGHT ROD	087035	1	
	END, LEFT ROD	087036	1	
19	BOLT, M12 X 60-8.8 HEX HEAD	F81004-5	2	
20	WASHER, 7.4 SAE FLAT	F81056-1	4	
21	NUT, M12-8 HEX NYLON LOCK	F81034-2	2	
22	NUT, M12-04-A RIGHT HEX JAM	F81034-6	1	
	NUT, M12-04-A LEFT HEX JAM	F81034-7	1	
23	PIN, CYLINDER MOUNT	086979-1	2	
24	WASHER, 28 SAE FLAT	F81061-1	4	
25	PIN, 5 X 40 COTTER	F81043-31	4	
	ROLLER KIT, SIDE SUPPORT	015109	2	
26	Roller Assembly, Side Support	015014-1	2	
27	Washer, 17 Flat	F81058-1	4	
28	Bolt, 5/8-11 x 3" Hex Head Grade 5	F05009-37	1	
29	Nut, 5/8-11 Nylon Lock	F05010-34	1	
	Instruction Sheet, Side Support Roller	015109-526	1	

9.7 Hydraulic Log Clamp

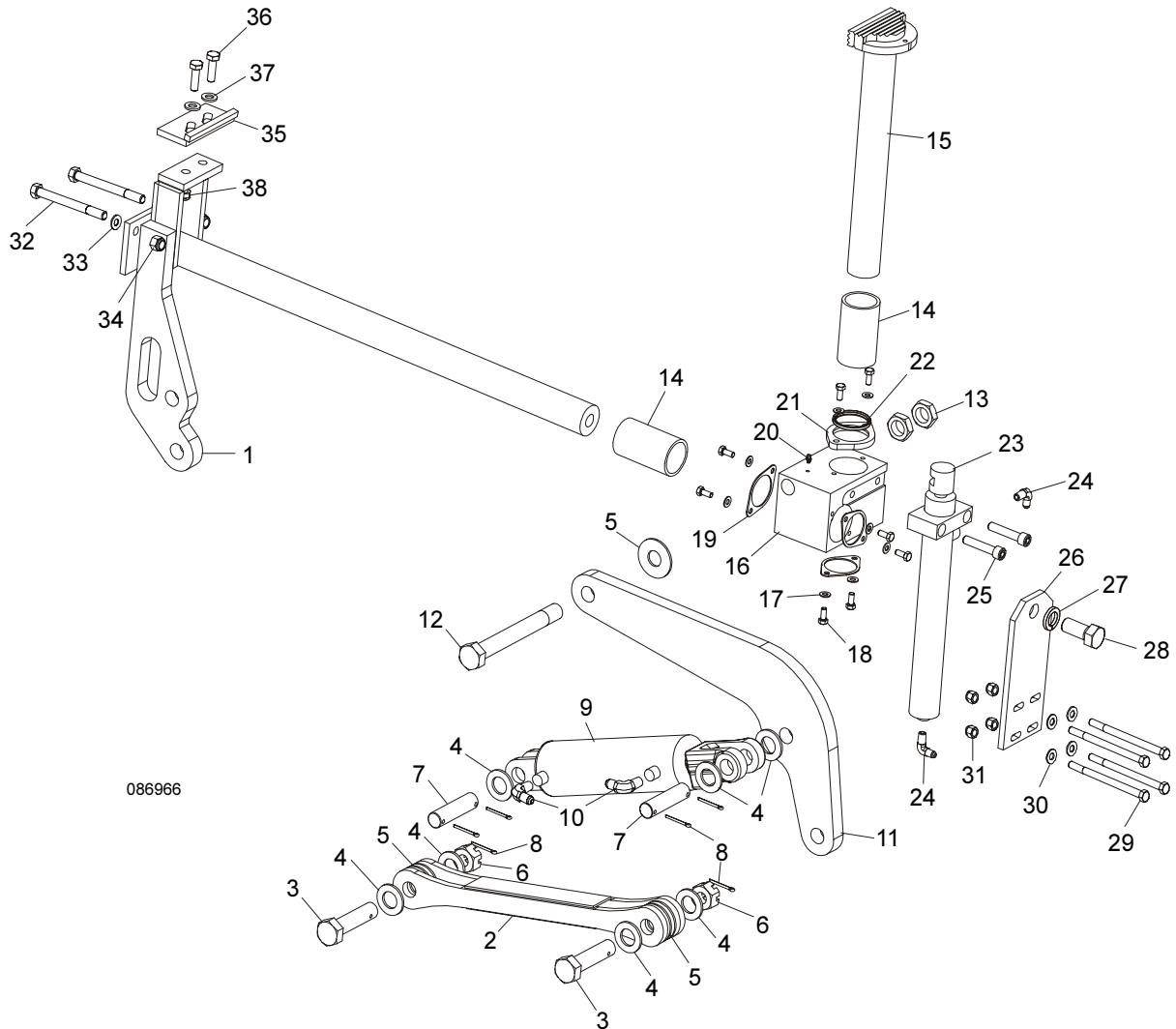

REF	DESCRIPTION (◆ Indicates Parts Available In Assemblies Only)	PART #	QTY.
	CLAMP ASSEMBLY, SUPER HYDRAULIC	088658	1
1	Mount Weldment, Super Clamp Tube	086967-1	1
2	Arm, Clamp Link	086963-1	1
3	Bolt, B 24x95/85 Hex Head Grade 8	F81049-2	1
4	Washer, 25 Flat	F81061-3	8
5	Washer, 25X63 Hardened	088585-1	5
6	Nut, M20-8-B Slotted Hex	F81037-3	2
7	Pin, Cylinder Mount	086979-1	2
8	Pin, 6,3x45 Cotter	F81045-2	6
9	Cylinder, CJ-S96-16-70/32/178 Hydraulic	088589	1
10	Fitting, 1/4" NPT - 3/8" JIC Elbow	P09142	2

11	Link Weldment, Super '99 Clamp	086974-1	1	
12	Bolt, M24x217/39 -8.8-B Hex Head Grade 8	088586-1	1	
13	Nut, M24 -04-B Hex Jam	F81039-3	2	
14	Bushing, Clamp Slide 5040BS	088660	2	
15	Clamp Weldment, Vertical Super	088582-1	1	
16	Block, Vertical Clamp Mount	088591-1	1	
17	Washer, 8.4 Flat	F81054-1	8	
18	Bolt, M8x20-8.8-B Hex Head	F81002-4	8	
19	Spacer, Log Clamp	088887-1	3	
20	Fitting, 3/16" Grease	P04107	1	
21	Spacer, Log Clamp	088887-1	1	
22	Wiper, Up/Down Rod ZZ 50x60x7	088587	1	
23	Cylinder, CJ-S169-16-40/22/254 Hydraulic	088590	1	
24	Fitting, 1/4" NPT - 1/4" JIC Elbow	P09142	2	
25	Screw, M12x55 -8.8-B Socket Head	F81004-23	2	
26	Plate, Super Log Clamp Mount	086975-1	1	
27	Washer, Z 22,5 Split Lock	F81059-4	1	
28	Bolt, M22x1,5x40 -8.8-B Hex Head Grade 5	F81009-1	1	
29	Bolt, M10 x 125-8.8 Hex Head	F81003-18	4	
30	Washer, 10.5 Flat	F81055-1	4	
31	Nut, M10-8-B Hex Nylon Lock	F81033-1	4	
32	Bolt, M10 x 140-8.8 Hex Head	F81004-37	2	
33	Washer, 13 Flat	F81056-1	2	
34	Nut, M12-8 Hex Nylon Lock	F81034-1	2	
	CLAMP STOP KIT, HYDRAULIC LOG	K09485	1	
35	Plate, Clamp Stop	086980-1	1	
36	Bolt, M12 x 40-8.8 Hex Head	F81004-4	2	
37	Washer, 13 Flat	F81056-1	2	
38	Nut, M12-8 Hex Nylon Lock	F81034-2	2	

9.8 Hydraulic Toe Board

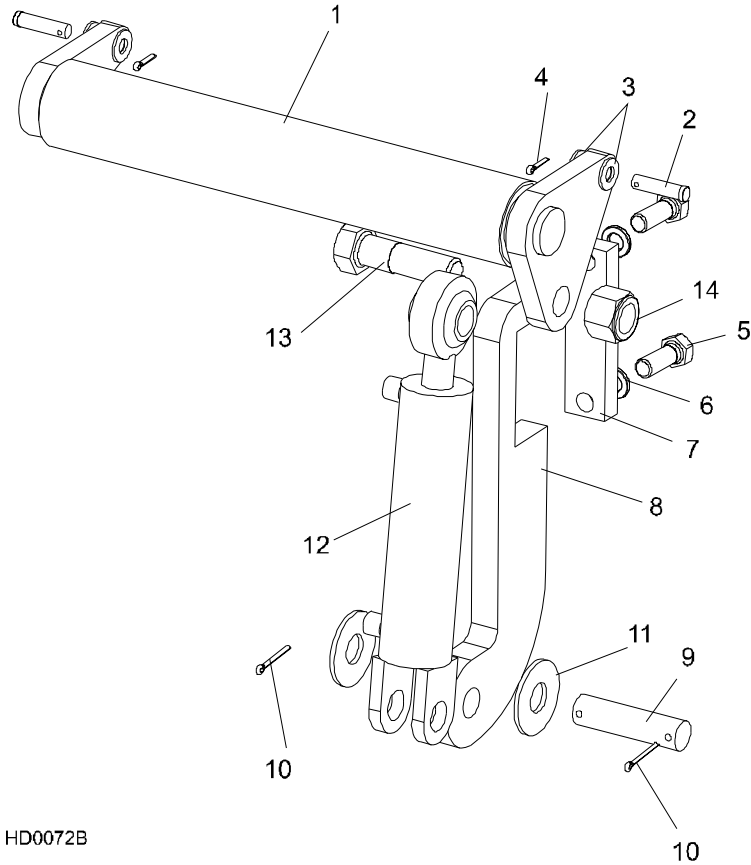

REF	DESCRIPTION (◆ Indicates Parts Available In Assemblies Only)	PART #	QTY.
1	TOE BOARD WELDMENT, HYDRAULIC	086253-1	2
2	PIN, 1/2-1 3/4 CLEVIS	F05012-82	4
3	WASHER, 13 SAE FLAT	F81056-1	8
4	PIN, S-ZN 2.5 X 20 COTTER	F81043-1	4
5	BOLT, 5/8-11 X 1 3/4" HEX HEAD	F05009-33	4
6	WASHER, 17 SPLIT LOCK	F81058-2	4
7	PLATE, HYDRAULIC TOEBOARD MOUNT	S13023-1	2
8	BRACKET, HYDRAULIC TOEBOARD MOUNT	087729	2
9	PIN, CYLINDER MOUNT	S09251	2
10	PIN, 3/16" X 1 1/2" COTTER	F05012-23	4
11	WASHER, 1" SAE FLAT	F05011-28	4
12	CYLINDER HYDR.CJ-S170-16-40/25/152	088681	2
	Seal Kit, 1 1/2" x 6" Hydraulic Cylinder	014547	1
13	BOLT, 1-8 X 3 1/4" HEX HEAD GRADE 5	F05009-51	2
14	NUT, 1-8 HEX NYLON LOCK	F05010-109	2
15	FITTING, 90° MALE ELBOW	P09143	4