

Wood-Mizer®

Parts Manual

LT40 Series AH

rev. D5.02



Safety is our #1 concern! Read and understand all safety information and instructions before operating, setting up or maintaining this machine.

November 1998

Form #921

Table of Contents

Section-Page

SECTION 1	GENERAL INFORMATION	1-1
1.1	How To Use The Parts List	1-1
1.2	Sample Assembly	1-1
SECTION 2	BLADE GUIDE ROLLERS & ARM	2-1
2.1	Blade Guide Assembly, Idle Side (Standard).....	2-1
2.2	Idle Side Blade Guide Assembly, Optional (LMS).....	2-3
2.3	Blade Guide Assembly, Drive Side.....	2-5
2.4	Blade Guide Arm & Rollers	2-7
2.5	Blade Guide Arm Drive Assembly.....	2-8
SECTION 3	BLADE WHEELS & TENSIONER	3-1
3.1	Blade Drive Assembly, LT40 Series AH	3-1
3.2	Idle Blade Wheel Assembly	3-3
3.3	Hydraulic Blade Tensioner Assembly.....	3-4
SECTION 4	SAW HEAD	4-1
4.1	Middle Throat Screw	4-1
4.2	Water Lube Solenoid Valve	4-1
4.3	Board Return Assembly	4-2
4.4	Water Lube Assembly	4-4
4.5	LT40AC Saw Head Decals	4-6
4.6	Blade Housing Covers.....	4-8
4.7	Drive Belt Covers	4-10
4.8	Sawdust Chute	4-11
SECTION 5	CONTROL & BATTERY BOXES	5-1
5.1	Control Assembly, LT40 Series AH	5-1
5.2	Control Box Bracket.....	5-3
5.3	Drum Switches	5-4
5.4	Circuit Breakers.....	5-5
SECTION 6	UP/DOWN SYSTEM	6-1
6.1	Saw Head V-Brace Mount.....	6-1
6.2	Blade Height Scale	6-2
6.3	Up/Down Chain & Sprockets.....	6-4
6.4	Up/Down Motor Assembly, LT40 Series AH.....	6-6
6.5	Up/Down Drive Assembly	6-7
6.6	Safety Switches	6-8

Table of Contents

Section-Page

SECTION 7	POWER FEED & TRACK ROLLERS	7-1
7.1	Upper Track Rollers And Wipers.....	7-1
7.2	Power Feed Assembly, LT40 Series AH.....	7-2
7.3	Feed Chain/Stop	7-4
7.4	Lower Track Rollers	7-6
SECTION 8	BED FRAME ASSEMBLY	8-1
8.1	Bed Rail Assembly, Front	8-1
8.2	Bed Rail Assembly, Rear	8-2
8.3	Bed Rail Assembly, Front Middle	8-3
8.4	Bed Rail Assembly, Rear Middle	8-4
8.5	Clamp Mount Assembly, Front (AH5/7).....	8-5
8.6	Clamp Mount Assembly, Rear (AH5/7).....	8-6
8.7	Leg, Stationary	8-7
8.8	Table, M Frame Sawmill with A/DH1-3 Hydraulics (option)	8-9
8.9	Table, M Frame Sawmill with A/DH4-7 Hydraulics (option)	8-10
8.10	Board Return Table, Stationary “M” Frame Option	8-11
8.11	Board Return Table (LT40M A/DH4-7 Option).....	8-13
8.12	Pivot Bed Rail Assembly.....	8-15
8.13	Bed Rail Assembly, Optional End.....	8-17
8.14	Log Side Support Assembly (Manual)	8-18
8.15	Tie Down Chain Assembly	8-19
8.16	Saw Head Rest Pin Assembly	8-19
8.17	Saw Head Rest Pin Assembly	8-20
8.18	Remote Equipment Option.....	8-21
8.19	Bed Frame Decals	8-22
SECTION 9	HYDRAULIC SYSTEM	9-1
9.1	Hydraulic Hoses, LT40 Series AH	9-1
9.2	Hydraulic Control Box, LT40 Series AH3	9-3
9.3	Hydraulic Control Box, LT40 Series AH5/7.....	9-5
9.4	Hydraulic Power Supply Strip.....	9-8
9.5	Hydraulic Log Loader	9-10
9.6	Hydraulic Log Turner	9-12
9.7	Hydraulic Log Side Supports	9-14
9.8	Hydraulic Log Clamp - main.....	9-16
9.9	Hydraulic Pull Down Clamp	9-18
9.10	Hydraulic Toe Board	9-20

SECTION 1 GENERAL INFORMATION

1.1 How To Use The Parts List

- Use the index above to locate the assembly that contains the part you need.
- Go to the appropriate section and locate the part in the illustration.
- Use the number pointing to the part to locate the correct part number and description in the table.
- Parts shown indented under another part are included with that part.
- Parts marked with a diamond (◆) are only available in the assembly listed above the part.

See the sample table below. Sample Part #A01111 includes part F02222-2 and subassembly A03333. Subassembly A03333 includes part S04444-4 and subassembly K05555. The diamond (◆) indicates that S04444-4 is not available except in subassembly A03333. Subassembly K05555 includes parts M06666 and F07777-77. The diamond (◆) indicates M06666 is not available except in subassembly K05555.

1.2 Sample Assembly				
REF	DESCRIPTION (◆ Indicates Parts Available In Assemblies Only)	PART #	QTY.	
	Sample Assembly, Complete (Includes All Indented Parts Below)	A01111	1	
1	Sample Part	F02222-22	1	
	Sample Subassembly (Includes All Indented Parts Below)	A03333	1	
2	Sample Part (◆ Indicates Part Is Only Available With A03333)	S04444-4	1	◆
	Sample Subassembly (Includes All Indented Parts Below)	K05555	1	
3	Sample Part (◆ Indicates Part Is Only Available With K05555)	M06666	2	◆
4	Sample Part	F07777-77	1	

To Order Parts:

- From Europe call our European Headquarters and Manufacturing Facility in Kolo, Poland at **+48-63-2626000**. From the continental U.S., call our toll-free Parts hotline at **1-800-448-7881**. Have your customer number, vehicle identification number, and part numbers ready when you call.
- From other international locations, contact the Wood-Mizer distributor in your area for parts.



CAUTION! It is strongly recommended to use original spare parts only.

SECTION 2 BLADE GUIDE ROLLERS & ARM

2.1 Blade Guide Assembly, Idle Side (Standard)

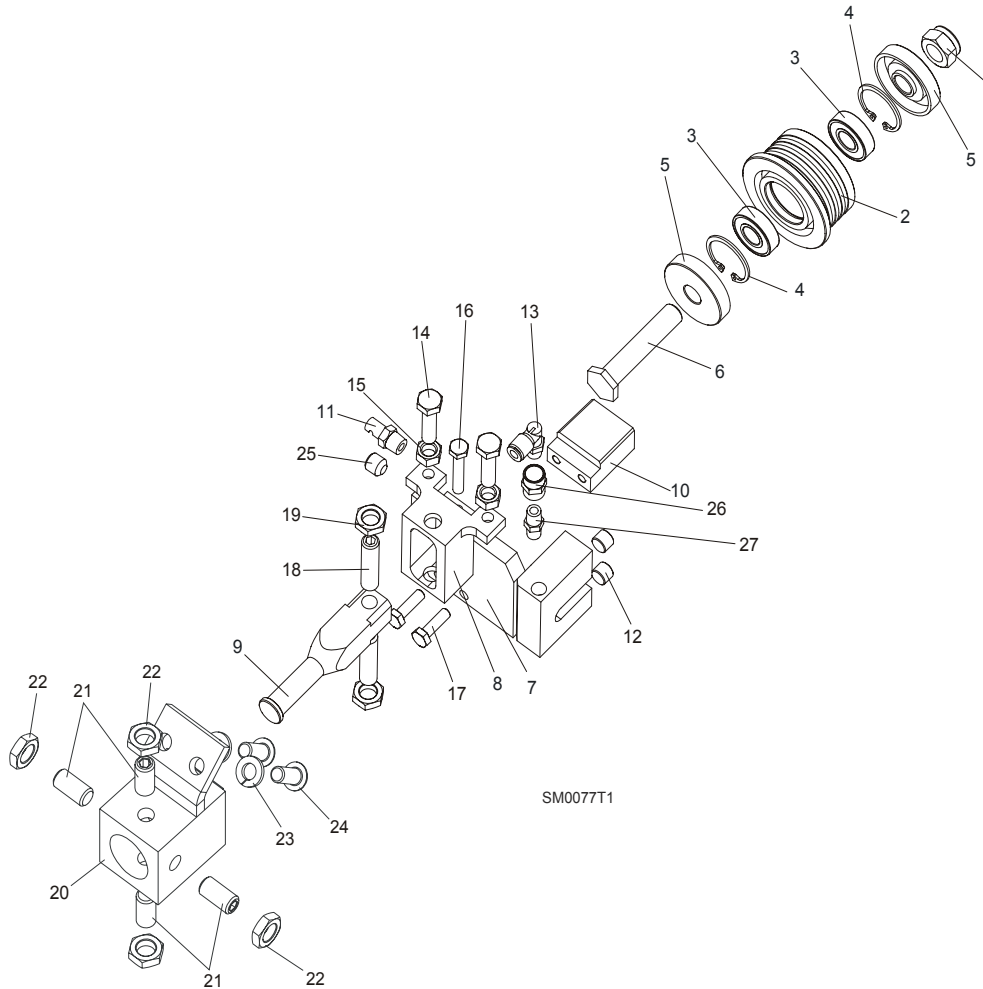

REF	DESCRIPTION (◆ Indicates Parts Available In Assemblies Only)	PART#	QTY.
	BLADE GUIDE ASSEMBLY, IDLE SIDE	092523	1
	Roller, Blade Guide Narrow W/Bearings	088261	1
	Roller, Blade Guide W/Bearings Extended (for optional use with 1 1/2" blades)	092939	1
1	Nut, M12-8 Hex Nylon Zinc Lock	F81034-2	1
2	Roller, Blade Guide Narrow	087889	1
	Roller, Blade Guide Extended (for optional use with 1 1/2" blades)	087890	1
3	Bearing, 6001 2RSR NACHI	087893	2
4	Ring, W28 Inside Retaining	F81090-9	2
5	Washer, Spacer	087891	2 (1)
	Washer, Spacer (used with the Extended Roller only) ¹	087892-1	1
6	Bolt, Blade Guide Roller Zinc-Plated	087761-1	1
	Bolt, Blade Guide Roller Zinc Plated (used with the Extended Roller only)	092940-1	1
7	Block Weldment, Nozzle Zinc-Plated	087750-1	1
8	Block, Zinc-Plated Roller Guide Adjuster	087756-1	1



Blade Guide Rollers & Arm

Blade Guide Assembly, Idle Side (Standard)

9	Shaft, Zinc-Plated Blade Guide Mount (Narrow Roller)	088255-1	1	
	Shaft, Zinc-Plated Blade Guide Mount (Wide Roller)	501406-1	1	
10	Block, Blade Guide Zinc	096956-1	1	
11	Nozzle, Blade Water Lube Spray	016637	1	
12	Plug, M10x1 DIN 906 BN40 "BOSSARD"	F81015-3	2	
13	Fitting, 90° Elbow 1/8NPT-1/4 Tube Swivel	P09736	1	
14	Bolt, M8x30 DIN933 A2-70 Stainless Steel	F81002-27	2	
15	Nut, M8 DIN934 A2-70 Stainless Steel	F81032-7	2	
16	Bolt, M6x30 DIN933 A2-70 Stainless Steel	F81001-37	1	
17	Bolt, M6x20-8.8 Hex Head Full Thread Zinc	F81001-2	2	
18	Screw, M10x1x40 DIN913 Stainless Steel Set	F81015-2	2	
19	Nut, M10x1-04-ST-A2 ISO 8675 Thin	F81033-10	2	
20	BLOCK WELDMENT, PAINTED BLADE GUIDE MOUNT	088292-1	1	
21	SCREW, M10X1X20 DIN913 STAINLESS STEEL SET	F81015-1	4	
22	NUT, M10x1-04-ST-A2 ISO 8675 THIN	F81033-10	4	
23	WASHER, 8.2 SPLIT LOCK ZINC	F81054-4	2	
24	BOLT, 5/16-18X3/4 SOCKET HEAD	F05006-102	2	
25	FITTING, 1/8 NPT SOCKET PIPE PLUG	P30127	1	
26	FITTING, 1/8FPT COUPLING	P05748	1	
27	NIPPLE, 1/8 DRY SEAL	P02764	1	

¹ Used only from the flanged side of the roller

2.2 Idle Side Blade Guide Assembly, Optional (LMS)

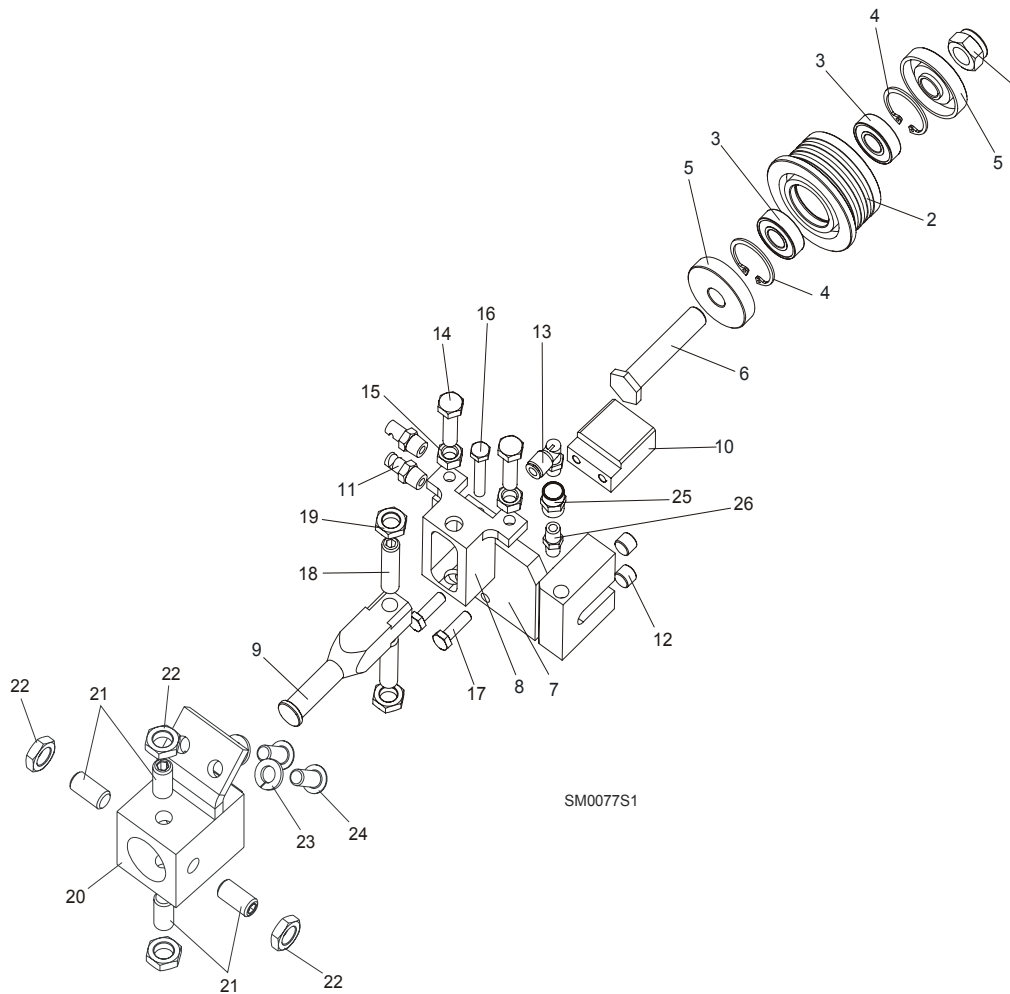

REF	DESCRIPTION (◆ Indicates Parts Available In Assemblies Only)	PART#	QTY.
	BLADE GUIDE ASSEMBLY, IDLE SIDE	087749	1
	Roller, Blade Guide Narrow W/Bearings	088261	1
	Roller, Blade Guide W/Bearings Extended (for optional use with 1 1/2" blades)	092939	1
1	Nut, M12-8 Hex Nylon Zinc Lock	F81034-2	1
2	Roller, Blade Guide Narrow	087889	1
	Roller, Blade Guide Extended (for optional use with 1 1/2" blades)	087890	1
3	Bearing, 6001 2RSR NACHI	087893	2
4	Ring, W28 Inside Retaining	F81090-9	2
5	Washer, Spacer	087891	2 (1)
	Washer, Spacer (used with the Extended Roller only) ¹	087892-1	1
6	Bolt, Blade Guide Roller Zinc-Plated	087761-1	1
	Bolt, Blade Guide Roller Zinc Plated (used with the Extended Roller only)	092940-1	1
7	Block Weldment, Nozzle Zinc-Plated	087750-1	1
8	Block, Zinc-Plated Roller Guide Adjuster	087756-1	1
9	Shaft, Zinc-Plated Blade Guide Mount (Narrow Roller)	088255-1	1
	Shaft, Zinc-Plated Blade Guide Mount (Wide Roller)	501406-1	1

10	Block, Blade Guide Zinc	096956-1	1	
11	Nozzle, Blade Lube Spray	033479	2	
12	Plug, M10x1 DIN 906 BN40 "BOSSARD"	F81015-3	2	
13	Fitting, 90° Elbow 1/8NPT-1/4 Tube Swivel	P09736	1	
14	Bolt, M8x30 DIN933 A2-70 Stainless Steel	F81002-27	2	
15	Nut, M8 DIN934 A2-70 Stainless Steel	F81032-7	2	
16	Bolt, M6x30 DIN933 A2-70 Stainless Steel	F81001-37	1	
17	Bolt, M6x20-8.8 Hex Head Full Thread Zinc	F81001-2	2	
18	Screw, M10x1x40 DIN913 Stainless Steel Set	F81015-2	2	
19	Nut, M10x1-04-ST-A2 ISO 8675 Thin	F81033-10	2	
20	BLOCK WELDMENT, PAINTED BLADE GUIDE MOUNT	088292-1	1	
21	SCREW, M10X1X20 DIN913 STAINLESS STEEL SET	F81015-1	4	
22	NUT, M10x1-04-ST-A2 ISO 8675 THIN	F81033-10	4	
23	WASHER, 8.2 SPLIT LOCK ZINC	F81054-4	2	
24	BOLT, 5/16-18X3/4 SOCKET HEAD	F05006-102	2	
25	FITTING, 1/8FPT COUPLING	P05748	1	
26	NIPPLE, 1/8 DRY SEAL	P02764	1	

¹ Used only from the flanged side of the roller

2.3 Blade Guide Assembly, Drive Side

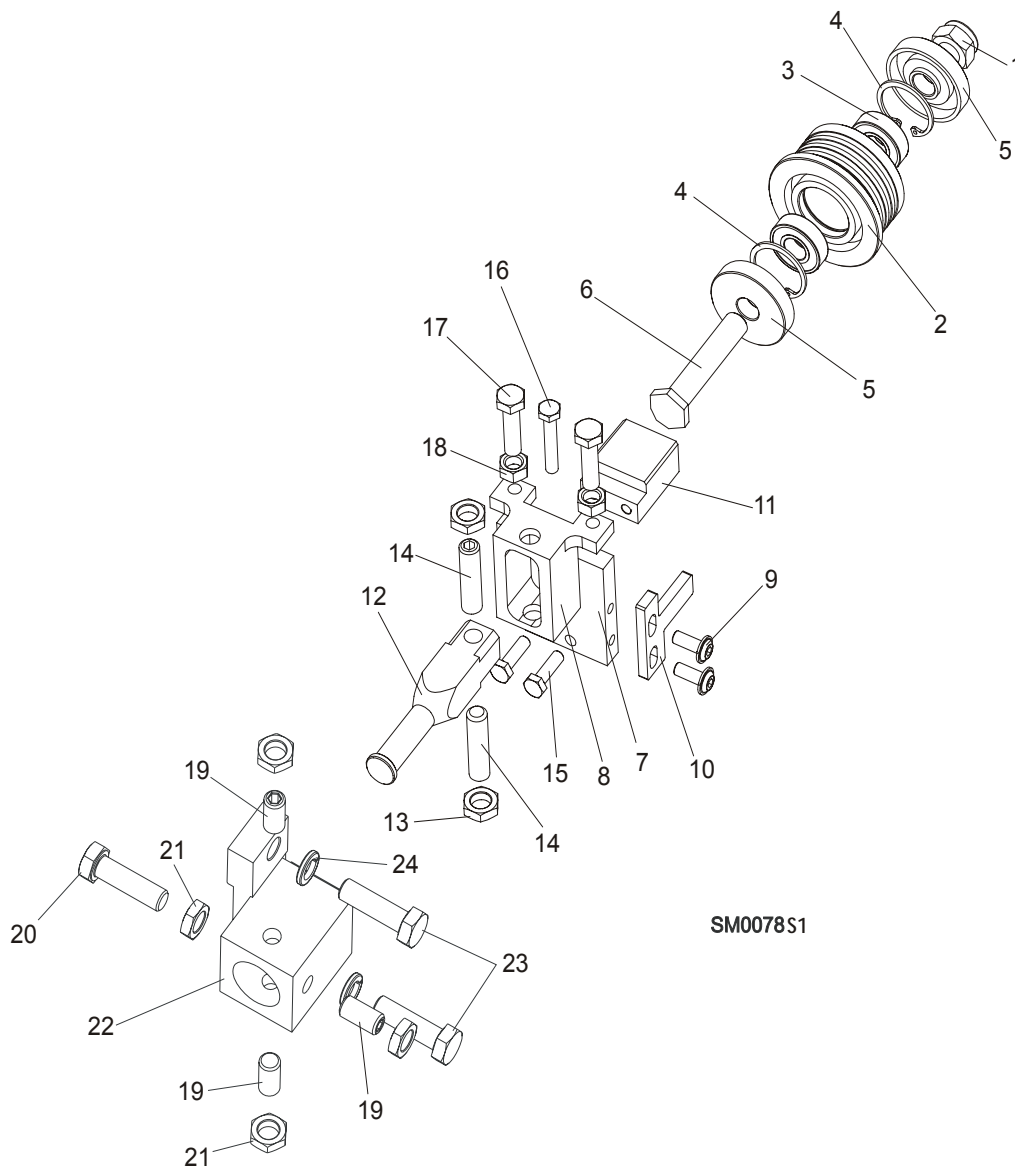

SM0078S1

REF	DESCRIPTION (◆ Indicates Parts Available In Assemblies Only)	PART#	QTY.
	BLADE GUIDE ASSEMBLY, DRIVE SIDE	087748	1
	Roller, Blade Guide Narrow W/Bearings	088261	1
	Roller, Blade Guide W/Bearings Extended (for optional use with 1 1/2" blades)	092939	1
1	Nut, M12-8 Hex Nylon Zinc Lock	F81034-2	1
2	Roller, Blade Guide Narrow	087889	1
	Roller, Blade Guide Extended (for optional use with 1 1/2" blades)	087890	1
3	Bearing, 6001 2RSR NACHI	087893	2
4	Ring, W28 Inside Retaining	F81090-9	1
5	Washer, Spacer	087891	2 (1)
	Washer, Spacer (used with the Extended Roller only) ¹	087892-1	1

6	Bolt, Blade Guide Roller Zinc-Plated	087761-1	1	
	Bolt, Blade Guide Roller Zinc Plated (used with the Extended Roller only)	092940-1	1	
7	Plate, Zinc-Plated Blade Guide Mounting	087753-1	1	
8	Block, Zinc-Plated Roller Guide Adjuster	087756-1	1	
9	Screw, M6x16 BN 11252 "BOSSARD"	F81001-24	2	
10	Wiper, Blade Zinc-Plated	087757-1	1	
11	Block, Blade Guide Zinc	096956-1	1	
12	Shaft, Zinc-Plated Blade Guide Mount (Narrow Roller)	088255-1	1	
	Shaft, Zinc-Plated Blade Guide Mount (Wide Roller)	501406-1	1	
13	Nut, M10x1-04-ST-A2 ISO 8675 Thin	F81033-10	2	
14	Screw, M10x1x40 DIN913 Stainless Steel Set	F81015-2	2	
15	Bolt, M6x20-8.8 Hex Head Full Thread Zinc	F81001-2	2	
16	Bolt, M6x30 DIN933 A2-70 Stainless Steel	F81001-37	1	
17	Bolt, M8x30 DIN933 A2-70 Stainless Steel	F81002-27	2	
18	Nut, M8 DIN934 A2-70 Stainless Steel	F81032-7	2	
19	Screw, M10X1X20 DIN913 Stainless Steel Set	F81015-1	3	
20	BOLT, M10X1X25 DIN 933 STAINLESS STEEL	F81003-28	1	
21	NUT, M10x1-04-ST-A2 ISO 8675 THIN	F81033-10	4	
22	BLOCK WELDMENT, BLADE GUIDE MOUNT	087744	1	
23	BOLT, M10X35-8.8 HEX HEAD FULL THREAD ZINC	F81003-17	2	
24	WASHER, 10.2 SPLIT LOCK ZINC	F81055-2	2	

¹ Used only from the flanged side of the roller

2.4 Blade Guide Arm & Rollers

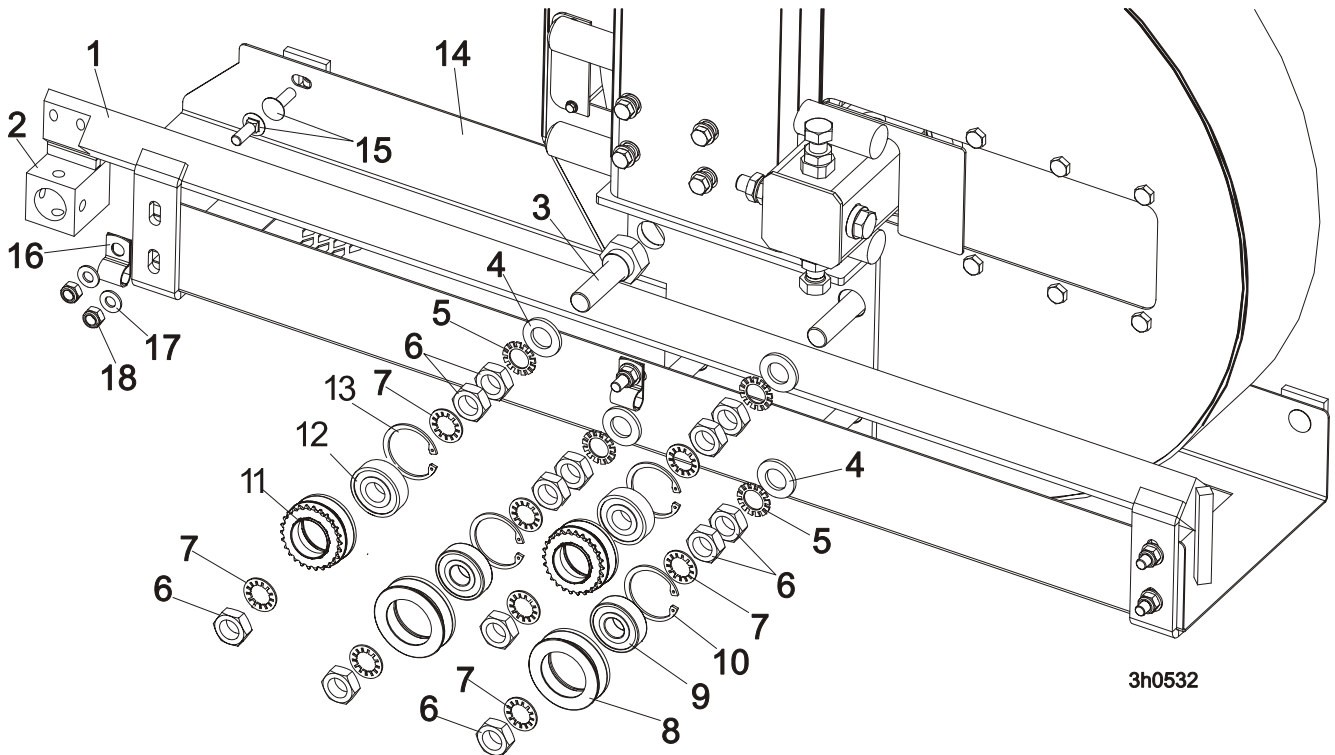

REF	DESCRIPTION (◆ Indicates Parts Available In Assemblies Only)	PART #	QTY.	
1	BLADE GUIDE ARM WELDMENT	087018-1	1	
2	BLOCK WELDMENT, PAINTED BLADE GUIDE MOUNT	088292-1	1	
3	BOLT, BLADE GUIDE ARM ROLLER CAM	086508-1	4	
4	WASHER, 17 FLAT	F81058-1	4	
5	WASHER, 5/8" EXTERNAL STAR	F05011-26	4	
6	NUT, 5/8-18 HEX JAM	F05010-11	12	
7	WASHER, 5/8" INTERNAL STAR	F05011-25	8	
	ROLLER ASSEMBLY, BLADE GUIDE ARM WITH BEARING	093855	2	
8	Roller, Blade Guide Arm V-Groove	093856-1	1	◆
9	Bearing, 6203-2RSP6-5/8 CX	095087	1	
10	Ring, W40 Retaining	F81090-3	1	
	ROLLER ASSEMBLY, BLADE GUIDE ARM WITH BEARING AND SPROCKET	501496	2	
11	Roller, Blade Guide Arm w/Sprocket	501495-1	1	◆
12	Bearing, 6203-2RSP6-5/8 CX	095087	1	
13	Ring, W40 Retaining	F81090-3	1	◆
14	GUIDE, BLADE	087042-1	1	
15	BOLT, M8x20-8.8 Fe/Zn5 PN-M/82406	F81002-11	7	
16	CLAMP, 1/2EMT COATED	P07584	2	
17	WASHER, 8.4 FLAT ZINC	F81054-1	7	
18	NUT, M8-8-B HEX NYLON ZINC LOCK	F81032-2	7	

2.5 Blade Guide Arm Drive Assembly

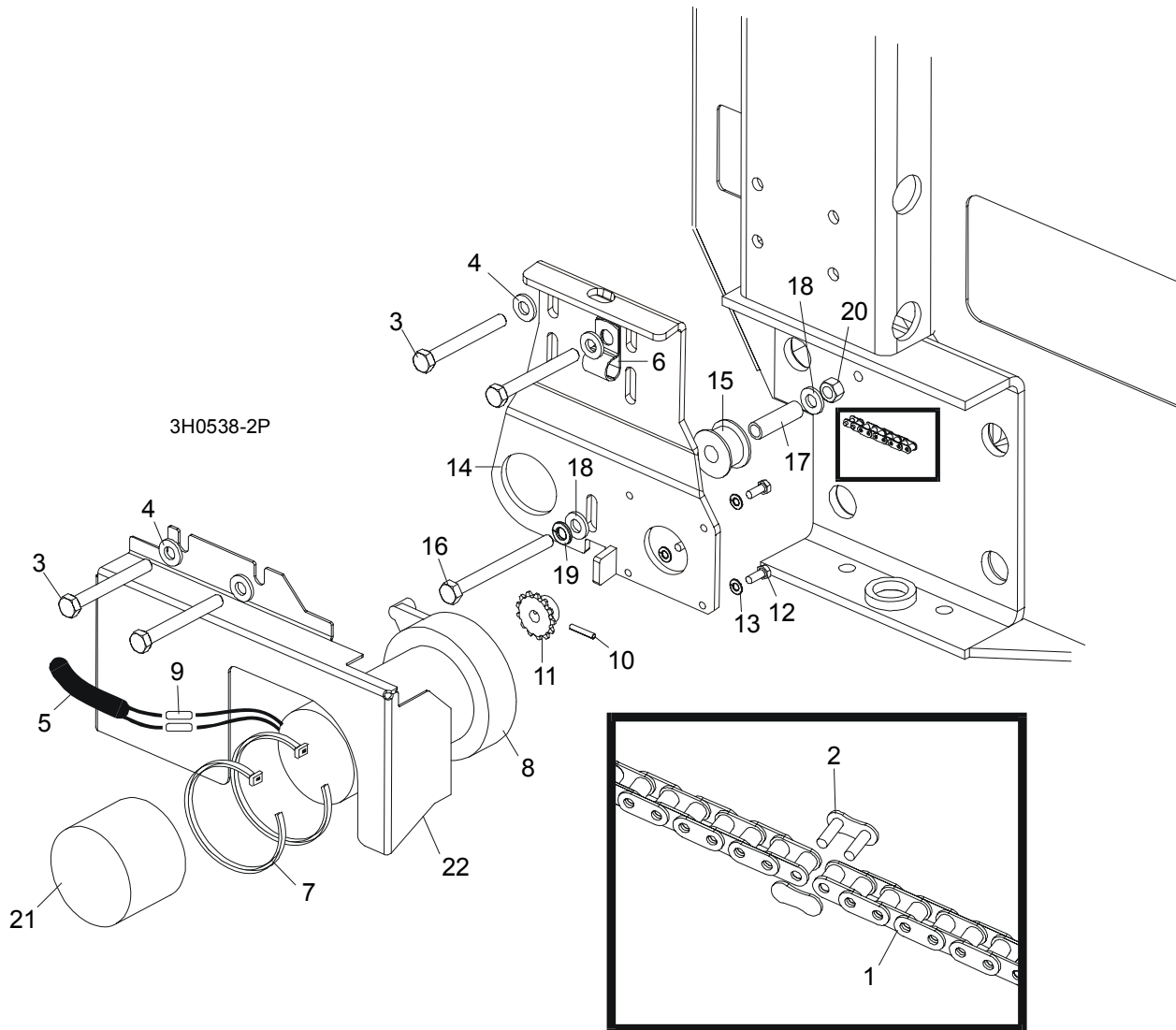

REF	DESCRIPTION (◆ Indicates Parts Available In Assemblies Only)	PART #	QTY.
1	CHAIN, #25 X 20 1/4"	P09984	1
2	LINK, #25 MASTER	P09983	1
3	BOLT, 5/16-18 X 2 3/4" HEX HEAD GRADE 5	F05006-28	4
4	WASHER, 8.4 FLAT	F81054-1	4
5	TUBE, 3/8" X 1/2" NEOPRENE	R01897	0,75 m
6	CLAMP, 1/2" COATED EMT	P07584	2
7	WRAP, 1/4" X 6" TIE	F05089-1	2
	DRIVE ASSEMBLY, BLADE GUIDE ARM	091005	1
	Motor Assembly, Blade Guide Arm Replacement	A10365	1
8	Motor, Blade Guide Arm 53:1 Gear	P09698-1	1
	Housing, Klauber Motor End	P12756	1
	Gear Kit, Klauber Motor Replacement	P12569	1
	Brush Kit, Gear Motor Replacement	P12800	1

	Shaft Kit, Klauber Gear Motor Replacement	009695	1	
9	Connector, 14 Gauge Butt	F04875-1	2	
10	Pin, 1/8" X 3/4" Roll	F05012-6	1	
11	Sprocket, Gear Motor #25 14-Tooth	P09970	1	
12	Screw, #10-32 x 1/2" Hex Head	F05004-60	4	
13	Washer, 4.1 Split Lock	F81051-4	4	
	Instruction Sheet, Blade Guide Arm Motor	A10353-296	1	
14	Bracket, Blade Guide Arm Motor Mount	087994-1	1	
15	Roller, Blade Guide Arm Chain Idler	S09999	1	
16	Bolt, 5/16-18 X 3 1/2" Hex Head Full Thread	F05006-3	1	
17	Spacer, 5/16" I.D. X 1 1/2"	S09996	1	
18	Washer, 5/16" SAE Flat	F81054-1	2	
19	Washer, 8.4 Split Lock	F05011-13	1	
20	Nut, 8.2 Hex Lock	F81054-4	1	
21	Boot, Gear Motor Weather	023720	1	
22	COVER, BLADE GUIDE ARM MOTOR	093460-1	1	

SECTION 3 BLADE WHEELS & TENSIONER

3.1 Blade Drive Assembly, LT40 Series AH

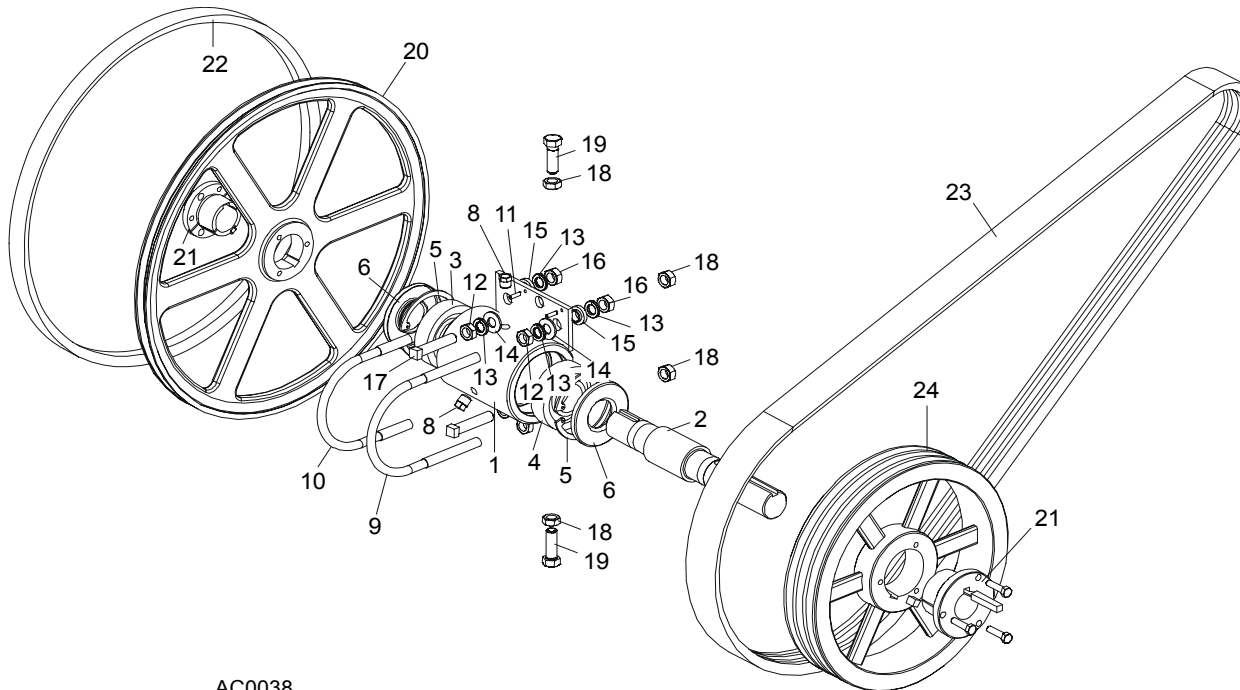

AC0038

REF	DESCRIPTION (◆ Indicates Parts Available In Assemblies Only)	PART #	QTY.
	BEARING ASSEMBLY, BLADE WHEEL DRIVE	086291	1
1	Housing, Blade Wheel Drive Bearing	086293	1
2	Shaft, Blade Wheel Drive	086292	1
3	Bearing, Blade Wheel Drive NJ308	085939	1
4	Bearing, Blade Wheel Drive #6308	085940	1
5	Ring, 90mm Interior Retaining #17	F04254-17	2
6	Seal, Drive Bearing #CR15890	P10206	2
7	Plug, 1/4" NPT Square Head	P05498	1
8	Plug, 1/4" NPT Vented	P12868	1
9	Bolt, 1/2-13 Long U	S10207-1P	1
10	Bolt, 1/2-13 Short U	S10207-2P	1
11	Pin, 3/16" X 5/8" Roll	F05012-22	2
12	Nut, 1/2-20 Hex Jam	F05010-16	4
13	Washer, 12.2 Split Lock	F81056-2	8
14	Washer, 13 SAE Flat	F81056-1	4
15	Spacer, .510" x .937" x .34"	S04253	4
16	Nut, 1/2-13 Hex	F05010-35	4
17	Screw, 1/2-20 x 2 1/2" Square Head Full Thread Set	F05008-110	2
18	Nut, M12-8 Hex Nylon Lock	F81034-2	4
19	Bolt, 1/2-20 x 1 1/2" Hex Head Grade 5	F05008-53	2
	Decal, Bearing End-Play	S12750	1

	Instruction Sheet, Bearing Retrofit	K10200-275	1	
	WHEEL KIT, DRIVE SIDE BLADE	014562	1	
20	Wheel, Drive Side Blade	016284	1	
21	Bushing, Modified 1 9/16" P1	087214	1	
	Instruction Sheet, Drive Side Blade Wheel Replacement	K12987-488	1	
22	BELT, BLADE WHEEL B57	P04185	1	
23	BELT, 3BX72 DRIVE (EA20, EA25)	014249	1	
24	PULLEY, 3B124 SK SPECIAL (EA20, EA25)	087203-1	1	

3.2 Idle Blade Wheel Assembly

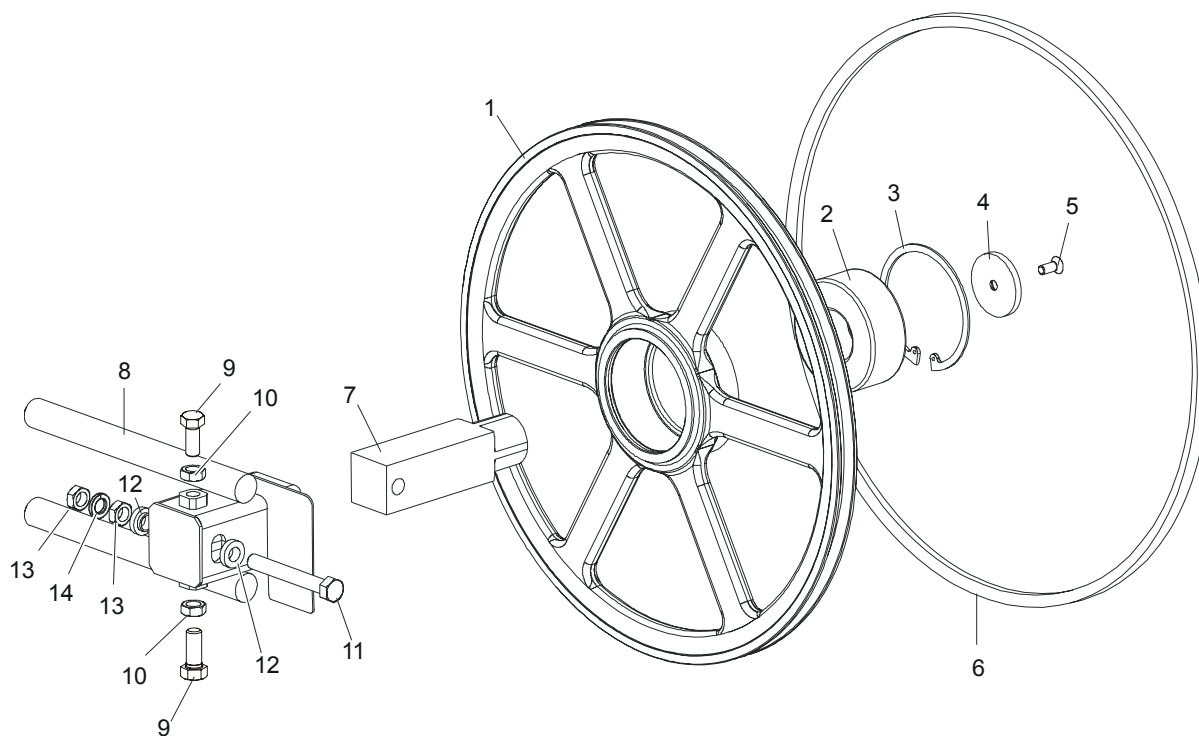

SM0241C

REF	DESCRIPTION (◆ Indicates Parts Available In Assemblies Only)	PART #	QTY.	
	WHEEL ASSEMBLY, IDLE SIDE BLADE	016120	1	
1	Wheel, Idle Side Blade	016013	1	◆
2	Bearing, Idle Side Blade Wheel 3309 B.2RSR TVH FAQ	086428	1	
3	Ring, 100mm Internal Retaining Beveled	F04254-28	1	
4	RETAINER, ZINC	095929-1	1	
5	BOLT, M10x25 -10.9- Fe/Zn5 DIN 7991	F81003-82	1	
6	BELT, BLADE WHEEL B57	P04185	1	
7	SHAFT, IDLE BLADE WHEEL	095732	1	
8	HOUSING, IDLE BLADE WHEEL SHAFT	016103	1	
9	BOLT, 1/2-20 X 1 1/2" HEX HEAD GRADE 5	F05008-53	2	
10	NUT, 1/2-20 HEX JAM	F05010-16	2	
11	BOLT, M12x1,25x100-8.8 HEX HEAD FULL THREAD GRADE 2	F81004-41	1	
12	SPACER, 1/2" I.D. FLANGED	086769-1	2	
13	NUT, M12x1,25 8.8 HEX JAM	F81034-5	2	
14	WASHER, 12.2 SPLIT LOCK	F81056-2	1	

3.3 Hydraulic Blade Tensioner Assembly

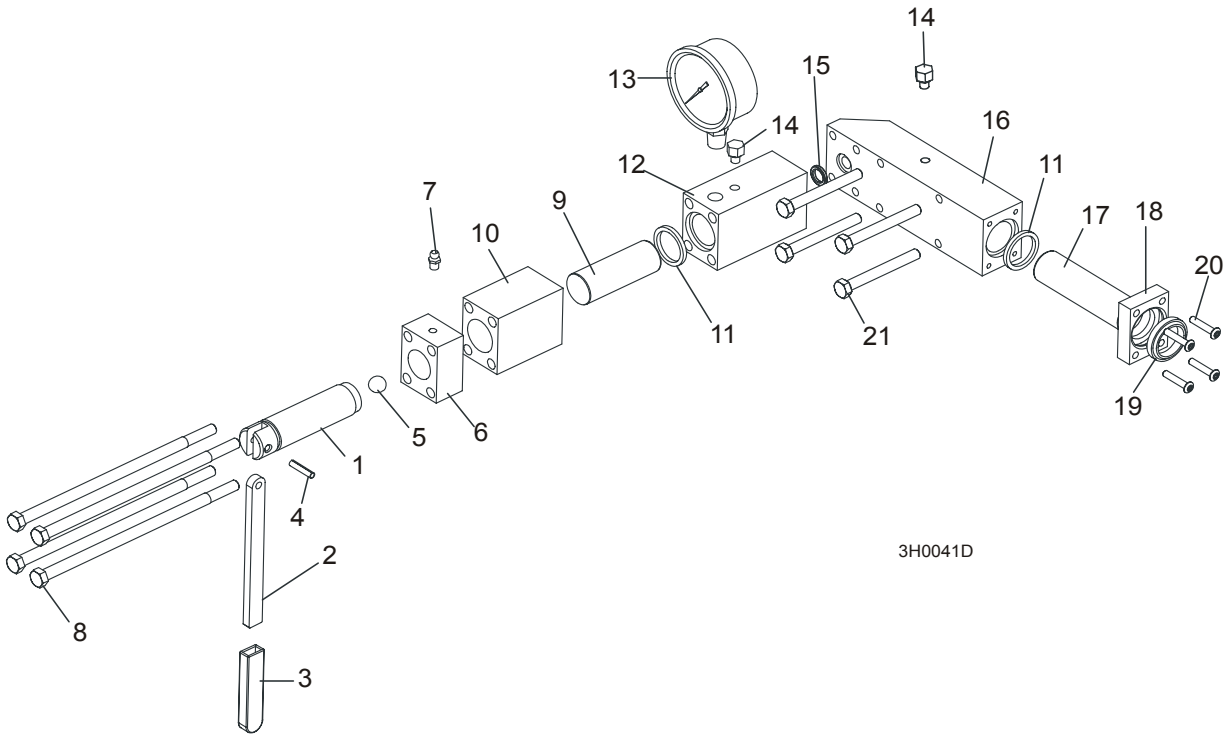

REF	DESCRIPTION (◆ Indicates Parts Available In Assemblies Only)	PART #	QTY.	
	HYDRAULIC BLADE TENSIONER ASSEMBLY	A10054	1	
	Handle Assembly, Hydraulic Blade Tensioner Screw	A12294	1	
1	Screw, Hydraulic Blade Tensioner	S10056	1	
2	Handle, Hydraulic Tensioner Screw	095930	1	
3	Sleeve, Plastic Handle	P08072	1	
4	Pin, 3/16" x 7/8" Roll	F05012-19	1	
5	Ball, 1/2" Steel	P02720	1	
6	Block, Threaded Tensioner End	S10062	1	
7	Fitting, 1/4-28 Grease	P05060	1	
	Instruction Sheet, Tensioner Screw	A12294-518	1	
8	Bolt, 5/16-18 X 7 1/2" Hex Head Grade 5	F05006-43	4	
9	Piston, Hydraulic Tensioner Front 2 3/4" Long	S10060	1	
10	Block, Piston Guide	S10061	1	
11	Seal, 1" Diameter	P10051	2	
12	Block, Hydraulic Tensioner Gauge Mounting	S10140	1	
13	Gauge, 3000 PSI	090552	1	
14	Plug, Hydraulic Tensioner Fill	P10065	1	
15	Ring, 5/8" X 3/32" Square "O"	P10377	1	
16	Block, Rear Tensioner Piston	S10142	1	
17	Piston, Hydraulic Tensioner Rear 3 5/8" Long	S10059	1	
18	Block, Rear Piston End	S10089	1	
19	Wiper, 1" Diameter	P10053	1	
20	Bolt, #10-24 X 1" Socket Button Head	F05004-43	4	
21	Bolt, 5/16-18 X 2 3/4" Hex Head Grade 5	F05006-28	4	
	Instruction Sheet, Hydraulic Tensioner Installation	A10136-272	1	



Blade Wheels & Tensioner

Hydraulic Blade Tensioner Assembly

SECTION 4 SAW HEAD

4.1 Middle Throat Screw

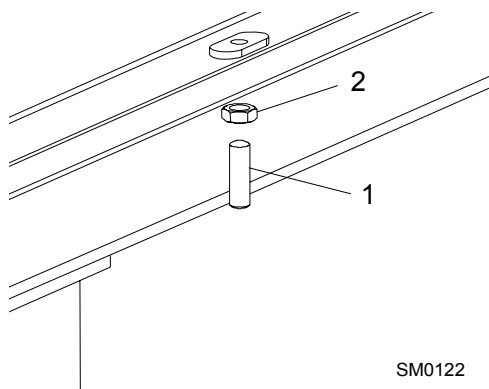

REF	DESCRIPTION (◆ Indicates Parts Available In Assemblies Only)	PART #	QTY.	
1	SCREW, 3/8-16 X 1 1/4" OVAL POINT SOCKET SET	F05007-18	1	
2	NUT, 3/8-16 HEX JAM	F05010-29	1	

4.2 Water Lube Solenoid Valve

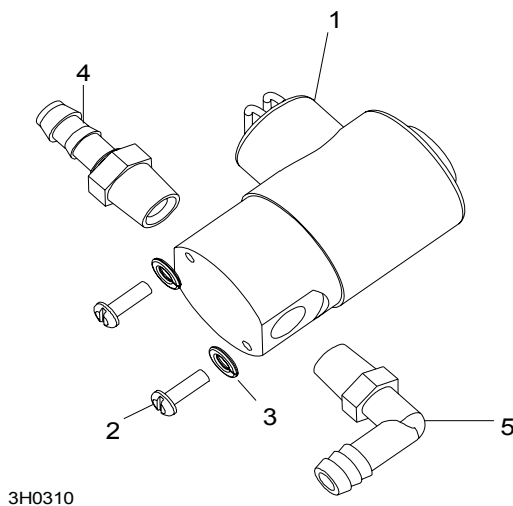

REF	DESCRIPTION (◆ Indicates Parts Available In Assemblies Only)	PART #	QTY.	
1	VALVE, WATER LUBE SOLENOID	016140	1	
2	SCREW, 4MM X 12 CROSS SLOT ROUND HEAD	F05004-74	2	
3	WASHER, 4MM SPLIT LOCK	F05011-57	2	
4	FITTING, 1/4" MALE NPT 3/8" HOSE BARB	P04682	1	
5	FITTING, 1/4" MALE NPT 3/8" HOSE BARB ELBOW	P04730	1	

4.3 Board Return Assembly

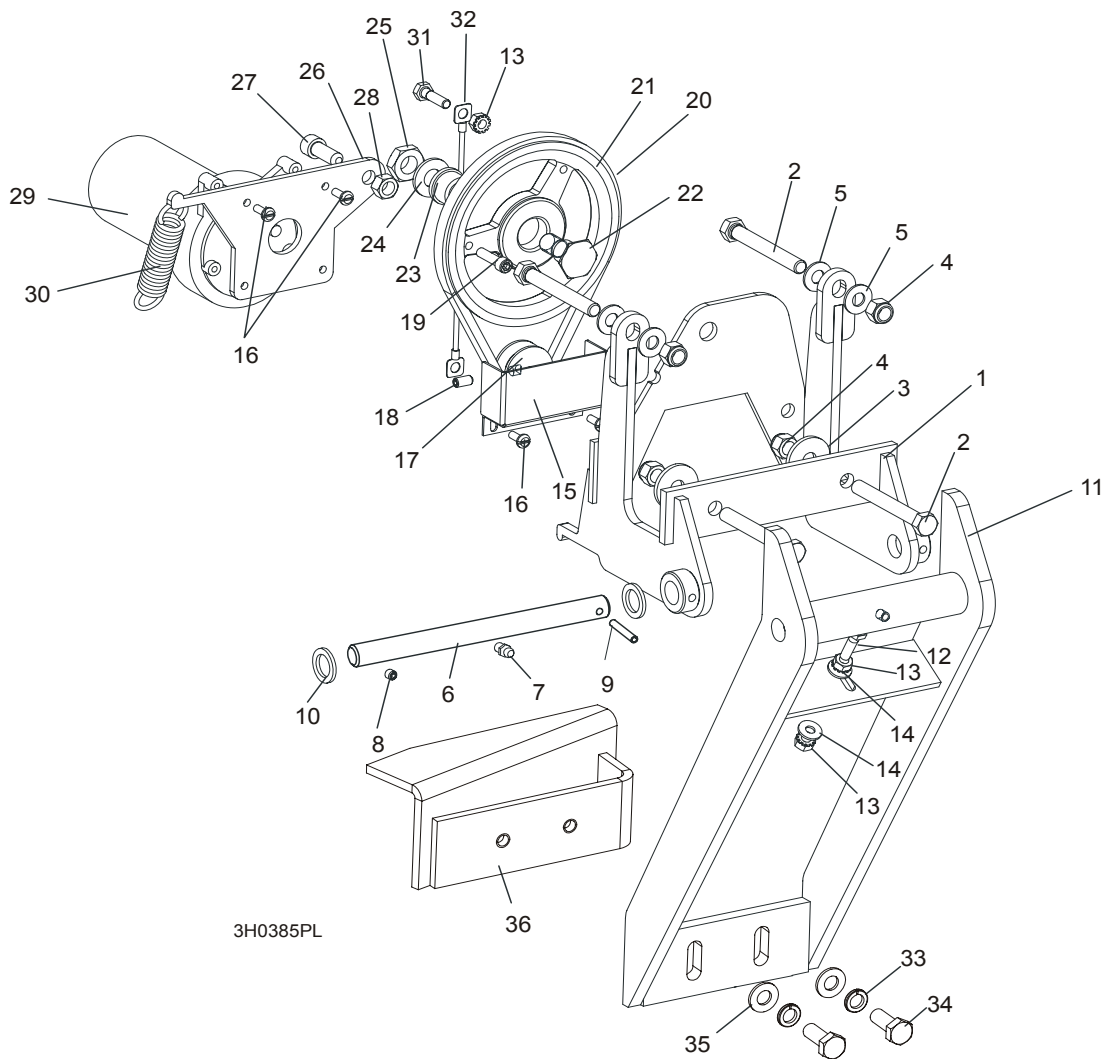

3H0385PL

REF	DESCRIPTION (◆ Indicates Parts Available In Assemblies Only)	PART #	QTY.
	RETURN ASSEMBLY, BOARD	087839-1	1
1	Mount Weldment, Board Return	087788-1	1
2	Bolt, 3/8-16 x 3" Full Thread Hex Head	F05007-1	4
3	Washer, 1/8" x 1 1/4"	015336	2
4	Nut, 3/8-16 Hex Nylon Lock	F05010-10	4
5	Washer, 10.5 Flat	F81055-1	4
6	Pin Kit, Board Return Replacement Pivot	087837	1
7	Fitting, M6 Grease	086280	1
8	Screw, M6 X 8 Black Oxide Socket Head Set Cup Point	F81013-1	1
9	Pin, 5 X 30 Roll	F81044-21	1
10	Washer, 5/8" x 15/16" x .094 Nylon	F05011-19	2
11	Arm Weldment, Board Return	087838-1	1
12	Screw, 1/4-20 x 3/4" Full Thread Hex Head Cap	F05005-101	1
13	Nut, 1/4-20 Self Locking	F05010-9	3

14	Washer, 7.4 Flat	F81056-11	2	
15	Guard, Board Return Belt	015007	1	
16	Screw, 10-32 x 1/2" Hex Head Machine	F05004-55	4	
17	Sheave, 1.42 x .32	015074	1	
18	Screw, 1/4-20 Socket Head Set Cup Point Nylon	F05005-55	1	
19	Screw, 1/4-20 x 1" Socket Head Cap	F05005-89	1	
20	Belt, 3L190	015477	1	
21	Sheave, OK50 x 1/2" Modified	015224	1	
22	Bolt, Idler Pulley Pivot	015221	1	
23	Bushing, 5/8" x 7/8" x 1/2" Bronze	P05135	1	
24	Washer, 13 Flat	F81056-1	1	
25	Nut, 1/2-20 Jam Nylon Lock	F05010-79	1	
26	Plate, Motor Pivot	087871	1	
27	Screw, M10 x 25-8.8 Black Oxide Socket Head Cap	F81003-32	1	
28	Nut, 3/8-16 Self Locking	F05010-25	1	
29	Motor, 53:1 ASA Gear	P09698-1	1	
30	Spring, 3/4" x 2 7/8" x 12 Gauge	015479	1	
31	Bolt, 1/4-20 x 1" Hex Head Grade 5	F05005-101	1	
32	Cable, Board Return	016090	1	
33	Washer, 10.2 Split	F81055-2	2	
34	Bolt, 3/8-16 x 3/4" Hex Head	F81003-1	2	
35	Washer, 10.5 Flat	F81055-1	2	
36	Angle, Board Return	087835-1	1	

4.4 Water Lube Assembly

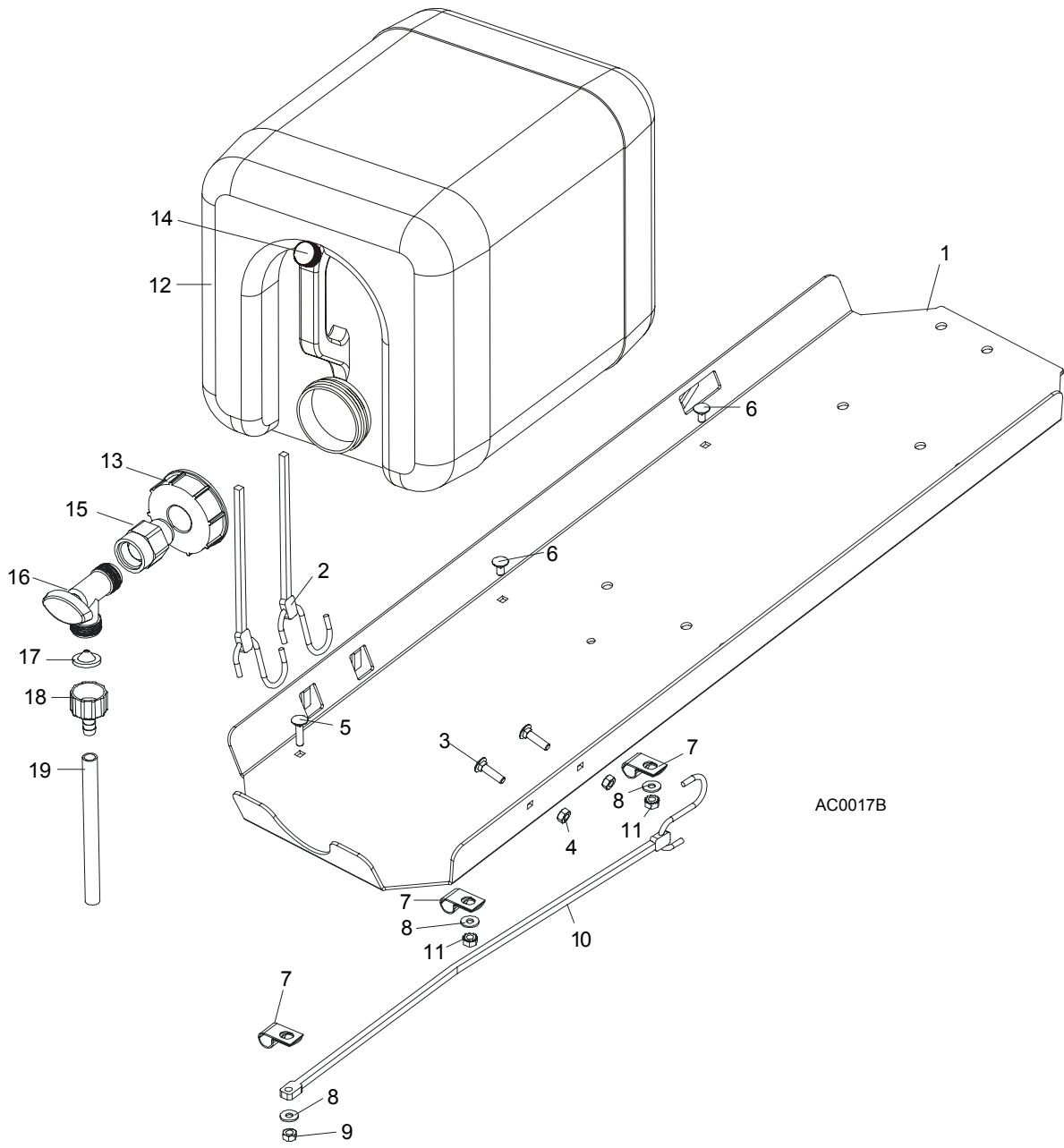

REF	DESCRIPTION (◆ Indicates Parts Available In Assemblies Only)	PART #	QTY.	
1	TRAY, ELECTRIC BOX/WATER BOTTLE	086528-1	1	◆
2	STRAP, 20" RUBBER	P11668	2	
3	BOLT, 1/4-20 X 1" CARRIAGE HEAD	F05005-34	4	
4	NUT, 1/4-20 HEX LOCK	F05010-21	4	
5	BOLT, 1/4-20 X 1" CARRIAGE HEAD	F05005-34	1	
6	BOLT, 1/4-20 X 1/2" CARRIAGE HEAD	F05005-33	2	
7	CLAMP, 1/2" EMT HOSE	P07584	3	
8	WASHER, 7.4 FLAT	F81056-11	3	
9	NUT, 1/4-20 HEX LOCK	F05010-21	1	

10	STRAP, 15" RUBBER	P07461	1	
11	NUT, 1/4-20 SELF-LOCKING	F05010-9	2	
	BOTTLE, 5-GALLON WATER COMPLETE	014637-1	1	
12	BOTTLE, 5-GALLON WATER	101295	1	
13	CAP, 5-GALLON WATER BOTTLE	036745	1	
14	CAP, VENT VALVE	061742	1	
15	FITTING, 3/4FPT X 3/4MPT	014636	1	
16	FITTING, WATER LUBE SHUTOFF VALVE	014100	1	
17	FILTER, WATER LUBE	016086 ¹	1	
18	FITTING, 5/8" NPT TO 3/8" HOSE BARB	014113	1	
19	TUBING, WATER LUBE 3/8" I.D.	R01885	2,1 m	

¹ Filter recommended for Super models to prevent debris from entering water lube solenoid valve.

4.5 LT40AC Saw Head Decals

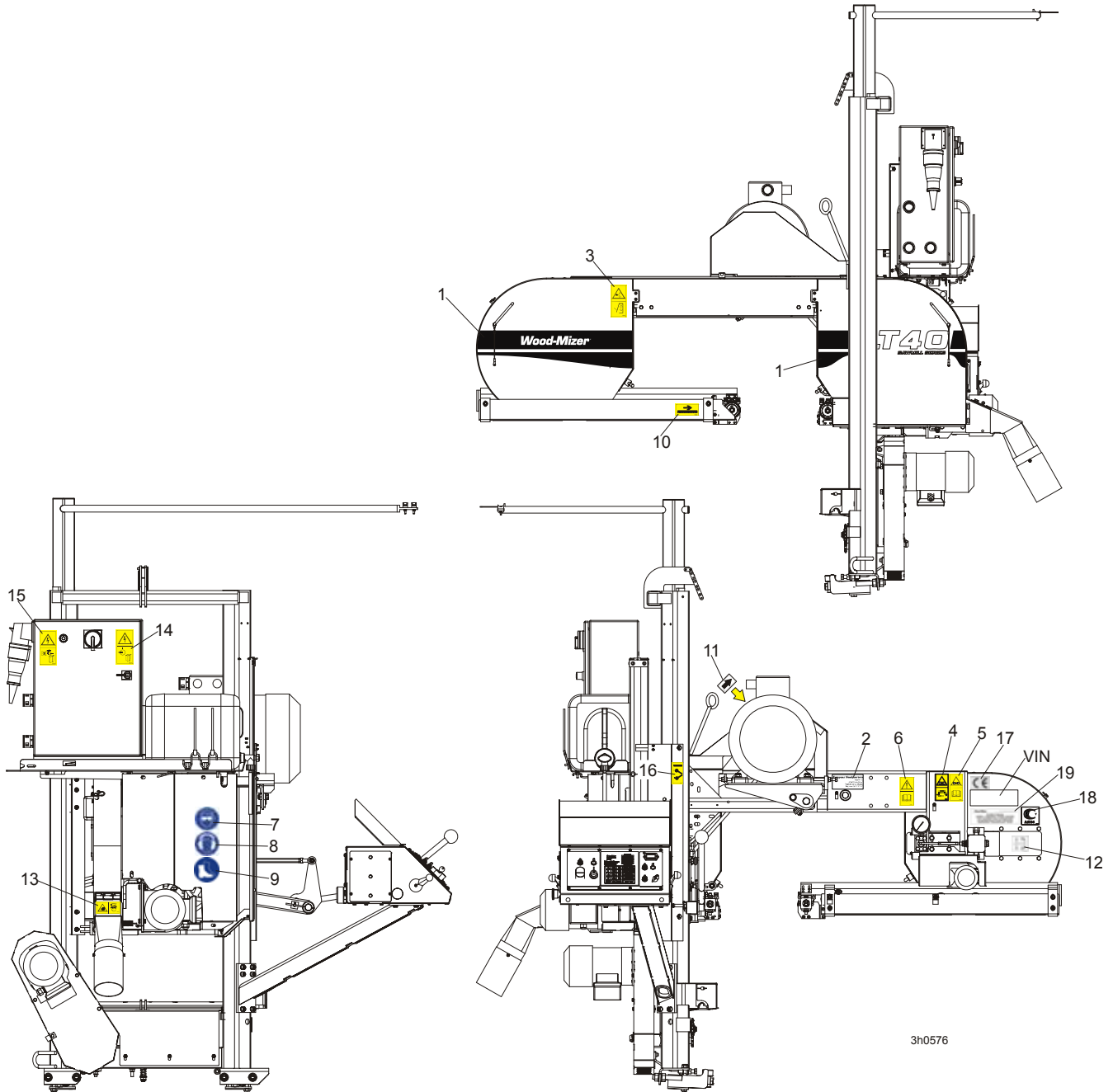

3h0576

REF	DESCRIPTION (◆ Indicates Parts Available In Assemblies Only)	PART #	QTY.
1	DECAL, LT40 SERIES SAWMILL	092763	1
	PICTOGRAPHIC DECAL KIT, LT40AC	099516	1
2	DECAL, EUROPEAN HEADQUARTERS ADDRESS	015841	1
3	DECAL, SAWMILL COVERS CAUTION	099220	2
4	DECAL, BLADE TENSION (PICTOGRAM)	099219	1
5	DECAL, BLADE TENSION - INSTRUCTIONS (PICTOGRAM)	099223	1
6	DECAL, READ OPERATOR'S MANUAL (PICTOGRAM)	096317	1

7	DECAL, EYE PROTECTION WARNING (PICTOGRAM)	S12004G	1	
8	DECAL, EAR PROTECTION WARNING (PICTOGRAM)	S12005G	1	
9	DECAL, USE SAFETY BOOTS (PICTOGRAM)	501465	1	
10	DECAL, BLADE MOVEMENT DIRECTION (PICTOGRAM)	096321	1	
11	DECAL, MOTOR ROTATION DIRECTION	S20097	1	
12	DECAL, BLADE ALIGNMENT	P11789	1	
13	DECAL, SAWDUST CHUTE WARNING (PICTOGRAM)	099222	1	
14	DECAL, HIGH VOLTAGE INSIDE THE ELECTRIC BOX (PICTOGRAM)	096316	2	
15	DECAL, REMOVE THE PLUG BEFORE OPENING THE BOX (PICTOGRAM)	096319	2	
16	DECAL, BLADE DRIVE WARNING (PICTOGRAM)	096315	1	
17	DECAL, CE CERTIFIED SAWMILL (SMALL)	P85070	2	
18	DECAL, RUSSIAN SAFETY CERTIFICATION	099401	1	
19	DECAL, INTERNATIONAL SAWMILL NAME	501466	1	
	DECAL, BLADE SETTING	P85066	1	
	DECAL, KEEP AWAY DANGER, PICTOGRAM	099221	1	
	DECAL, MAX. OIL PRESSURE, PICTOGRAM	099524	1	

4.6 Blade Housing Covers

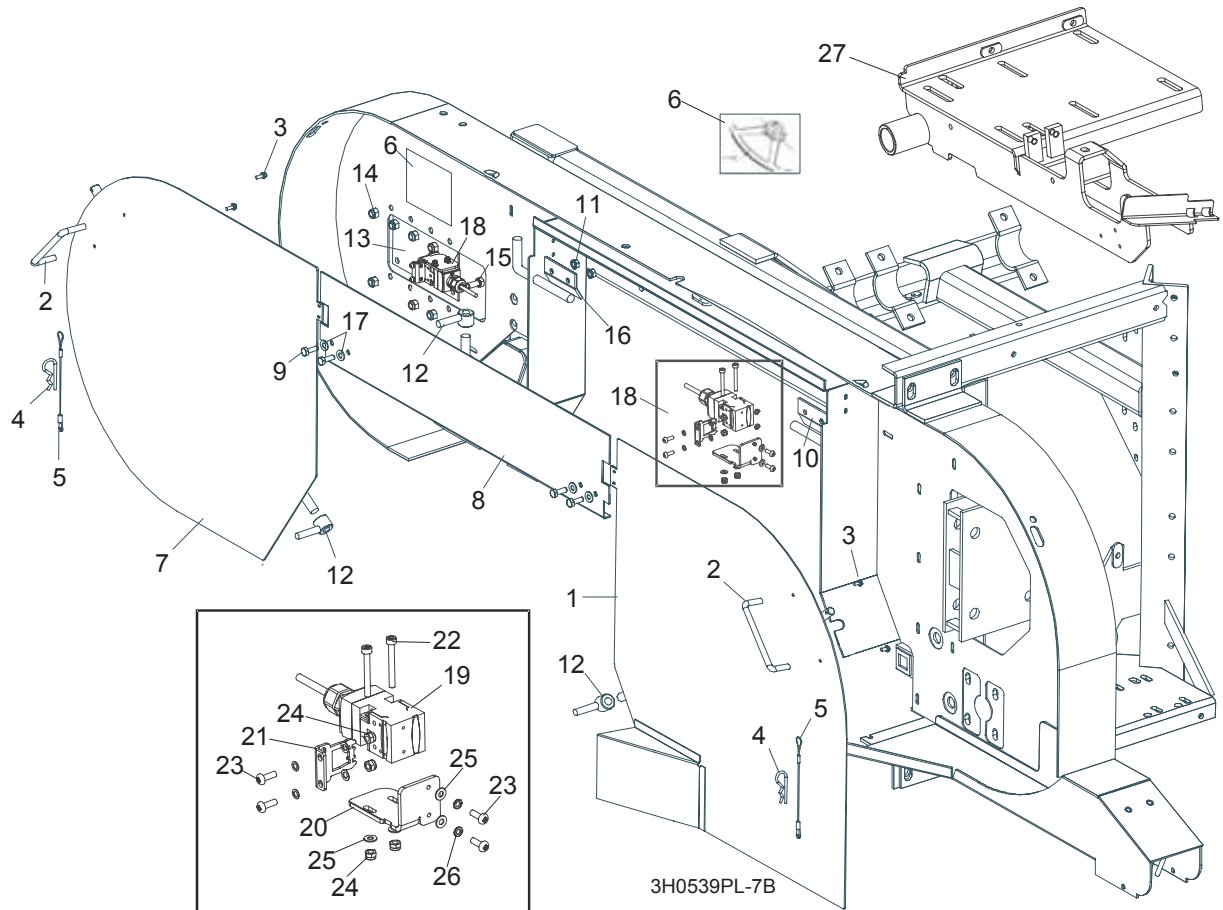

REF	DESCRIPTION (◆ Indicates Parts Available In Assemblies Only)	PART #	QTY.
	COVER ASSEMBLY, DRIVE SIDE BLADE HOUSING WITH HANDLE	086195	1
1	Cover Weldment, Drive Side Blade Housing	087159-1	1 ◆
2	Handle, Blade Housing Cover	P08065	1
3	Screw, #8-32 x 3/8"	F05015-8	2
	Pin Assembly, Cover Retainer	A11881	1
4	Pin, Safety Retainer	N/A	1
5	Cable, 3/64" x 6" Lanyard	N/A	1
6	DECAL, BLADE SETTING	P85066	1
	COVER, IDLE SIDE BLADE HOUSING WITH HANDLE	086431	1
7	Cover, Idle Side Blade Housing	086430-1	1 ◆
2	Handle, Blade Housing Cover	P08065	1
3	Screw, #8-32 X 3/8" Self-Tap	F05015-8	2
	Pin Assembly, Cover Retainer	A11881	1
4	Pin, Safety Retainer	N/A	1
5	Cable, 3/64" x 6" Lanyard	N/A	1
8	COVER, MIDDLE BLADE HOUSING	087326-1	1
9	BOLT, 1/4-20 X 3/4" HEX HEAD	F05005-1	4

10	HINGE, MIDDLE BLADE HOUSING COVER	S07522	1	
11	NUT, 1/4-20 SELF-LOCKING HEX	F05010-9	4	
12	NUT, COVER TURN	086365-1	2	
13	PLATE, IDLE BLADE WHEEL GUARD	086230	1	
14	NUT, 5/16-18 HEX NYLON LOCK	F05010-58	6	
15	BOLT, 5/16-18 X 3/4" HEX HEAD GRADE 2	F05006-5	6	
16	HINGE, MIDDLE BLADE HOUSING COVER	085336-1	1	
17	WASHER 6.4 ZINC	F81053-1	4	
18	SWITCH ASSEMBLY, SAFETY SHUT-OFF	094301	2	
19	Safety Switch, AZ17-11ZRK	094232	2	
20	Bracket, Safety Switch Mount Painted	094300-1	2	
21	Key, AZ17/170-B5 Safety Switch	094422	2	
22	Bolt, M4 x 35-8.8 Socket Head	F81011-34	4	
23	Screw, M4 x 12-5.8	F81011-43	8	
24	Nut, M4 Hex	F81029-1	8	
25	Washer, M4 Split Lock Zinc	F81051-1	4	
26	Washer, 4.3	F81051-2	8	
27	MOUNT WELDMENT E15,E20,E25	087736-1	1	

4.7 Drive Belt Covers

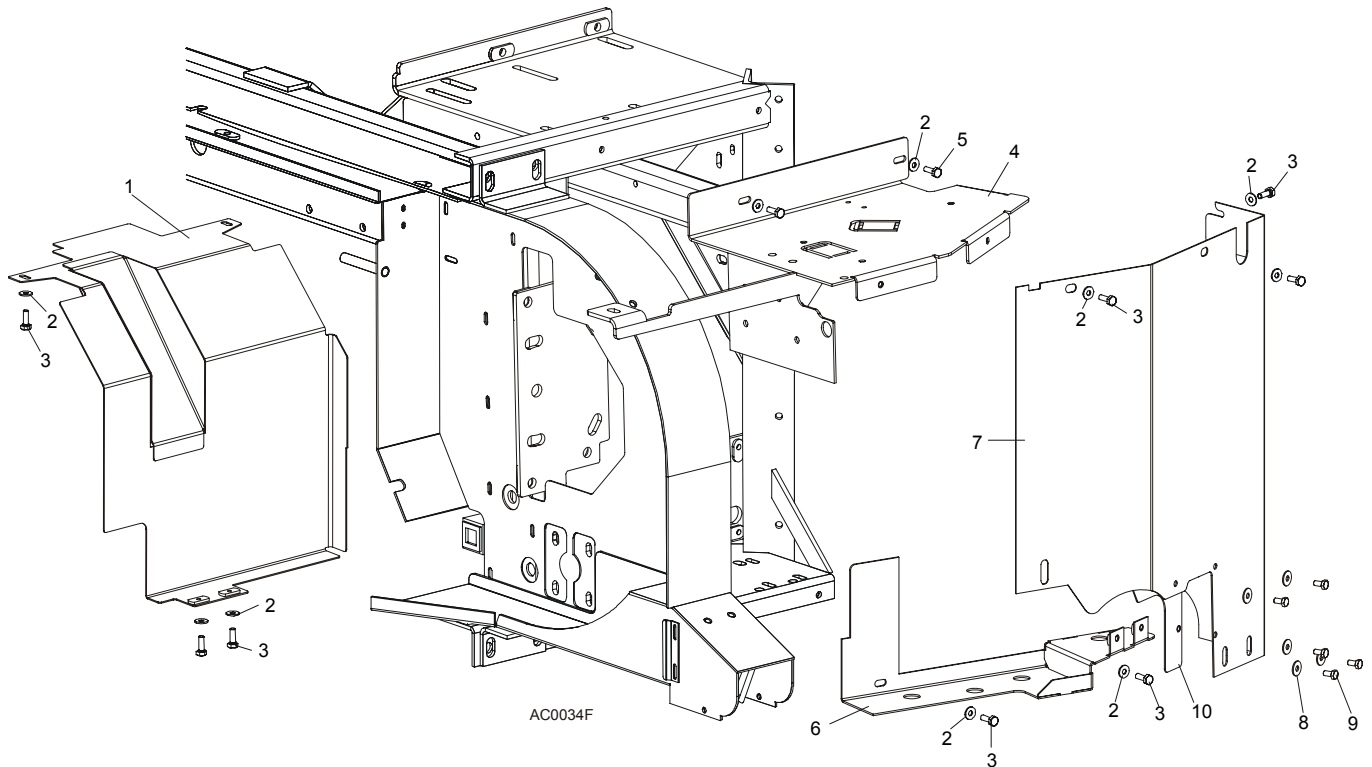

REF	DESCRIPTION (◆ Indicates Parts Available In Assemblies Only)	PART #	QTY.
1	GUARD, E15/E20/E25 BELT LOWER PAINTED	087660-1	1
2	WASHER, 6.5 SPECIAL FLAT ZINC	F81053-11	11
3	BOLT, M6 X 20-8.8 HEX HEAD FULL THREAD ZINC	F81001-2	9
4	GUARD WELDMENT, AC SAW HEAD UPPER PAINTED	086621-1	1
5	BOLT, M6 X 12-8.8 HEX HEAD FULL THREAD ZINC	F81001-7	2
	GUARD, AC SIDE PAINTED COMPLETE (WITHOUT BRAKE)	100621	1
	GUARD, AC SIDE PAINTED COMPLETE (WITH BRAKE)	100622	1
6	GUARD, AC LOWER	087525-1	1
7	GUARD, AC SIDE PAINTED (WITHOUT BRAKE)	086420-1	1
	GUARD, AC SIDE PAINTED (WITH BRAKE)	087333-1	1
8	WASHER, 6.5 SPECIAL FLAT ZINC	F81053-11	5
9	BOLT, M6 X 12-8.8 HEX HEAD FULL THREAD ZINC	F81001-7	5
10	PLATE, CAP COMPLETE	501393-1	1

4.8 Sawdust Chute

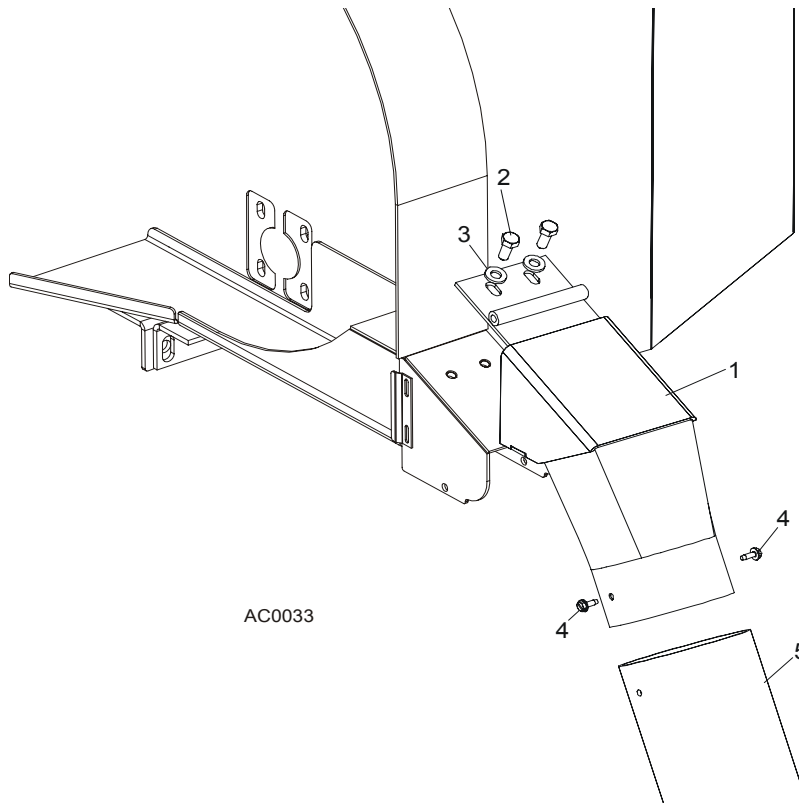

REF	DESCRIPTION (◆ Indicates Parts Available In Assemblies Only)	PART #	QTY.	
1	CHUTE , LT40 SAWDUST	501500-1	1	
2	BOLT, M8x16	F81002-20	2	
3	WASHER, 8.4 FLAT	F81054-1	2	
4	BOLT, #10-24 X 1/2" SELF-TAPPING	F05015-7	2	
5	TUBING, 4" I.D. RUBBER	086364	0.6 m	
	STRAP, 20" RUBBER W/HOOK	P11668	1	
	BOLT, 1/4-20 X 1 1/4" HEX HEAD FULL THREAD	F05005-3	1	
	WASHER, 7.4 FLAT	F81056-11	1	
	NUT, 1/4-20 LOCK	F05010-21	1	

SECTION 5 CONTROL & BATTERY BOXES

5.1 Control Assembly, LT40 Series AH

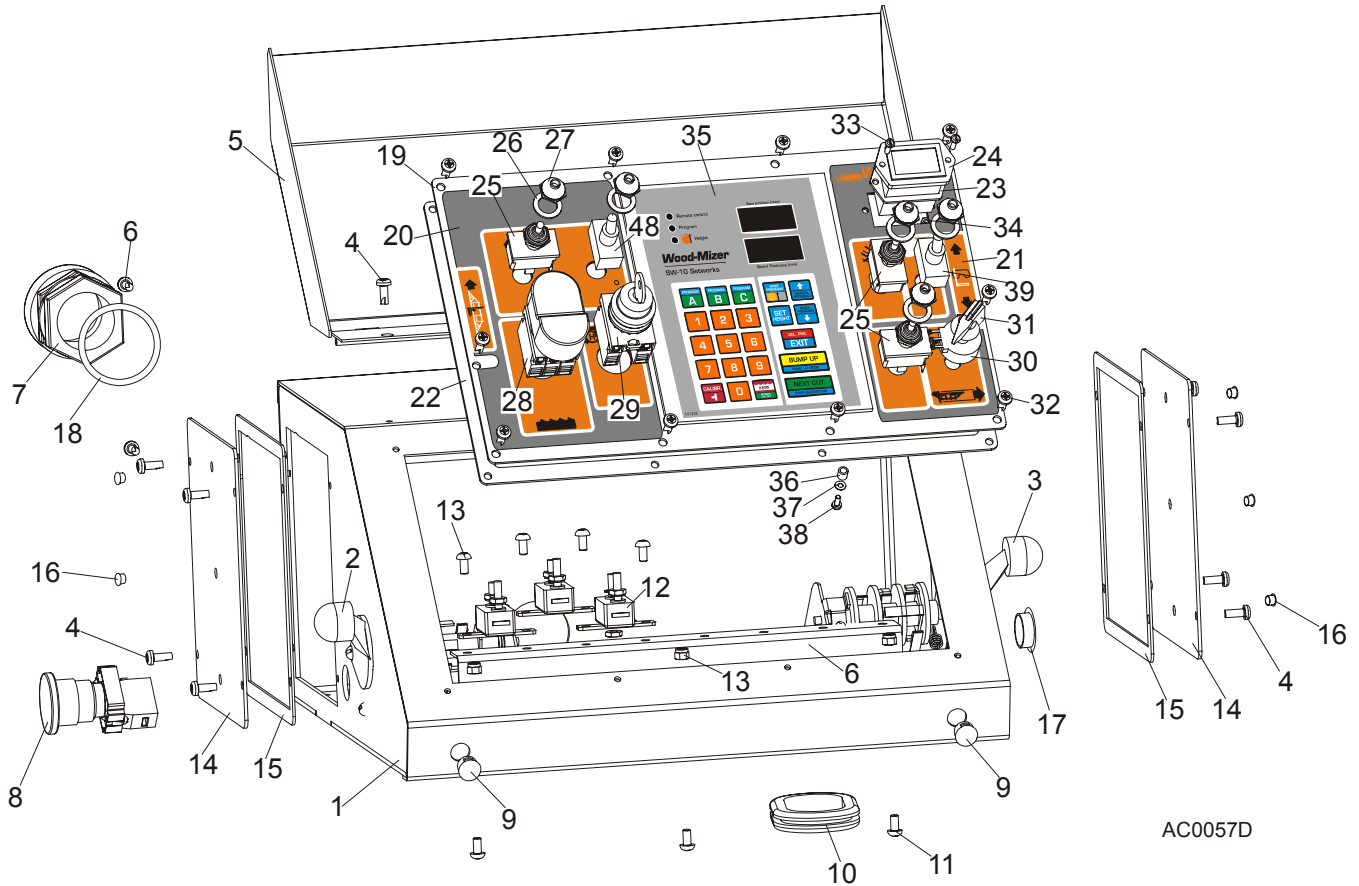

REF	DESCRIPTION (◆ Indicates Parts Available In Assemblies Only)	PART #	QTY.
	CONTROL BOX ASSEMBLY, LT40 AC	098690	1
1	Control Box, LT40AC	099622-1	1
2	Switch, 1992GS Pwr/Feed (Service Package)	E20438	1
3	Switch, 1992 Up/Down (Service Package)	E20440	1
4	Bolt, #10-24x1/2 Ph Pan Hd, Type 23	F05015-17	12
5	Cover Weldment, LT20/40 Complete	097135-1	1
6	Rail, Circuit Breaker	015310	1
7	Connector, 1 1/4 Straight Metal Conduit	024402	1
8	Switch, XB2 BS542 Emergency	086556	1
9	Switch, Speed Control	086773	2
10	Grommet, Rubber	087065	1
11	Screw, H M5x10 8.8 Zinc	F81000-13	7
12	Breaker, 15A Manual Reset	E20430	3
13	Nut, M5-8 Zinc	F81030-2	3
	Cover, Control Box Side Complete	086700	2
14	Cover, Control Box Side	086699-1	1
15	Gasket, Control Box Side	015274	1

16	Cap, SR1086 6.4 Dia. Hole	099700	6	
17	Cap, SR1086 22.2 Dia. Hole	093544	1	
18	Seal, 1 1/4 Ring LQTI w/Retainer	015430	1	
	Panel, LT40 AC Front Control Complete	098689	1	
19	Panel, LT20/40 AC Front Control	100572-1	1	
	Panel, LT40 AC Front Control	098586-1 ¹	1	
20	Decal, LT20/40 AC Control Box Left	099594	1	
21	Decal, LT40 DC Control Box Right	099596	1	
22	Gasket, LT20/40 Control Box	097132	1	
23	Gasket, Hour Meter	093346	1	
24	Meter, Hour	093166	1	
25	Switch, Toggle	024000	3	
26	Washer, 1/2x3/4x1/16 Nylon	P05251-1	5	
27	Boot, Toggle Switch	P02575	5	
28	Button, 24V Start/Stop	090452	1	
	Membrane M22-T-DD	090462	1	
29	Switch, M22 3-position Key	091361	1	
30	Potentiometer, 1k Feed Rate	E20519	1	
31	Knob, Speed Control	P06257	1	
32	Bolt, #10-24x1/2 Ph Pan Hd, Type 23	F05015-17	10	
33	Bolt, M3x12-8.8 Zinc	F81000-12	2	
34	Nut, M3-6 Nylon Zinc Lock	F81028-2	2	
35	Controller, SW-10 Setworks	500628	1	
36	Spacer, 4.2x6mm Idler	R80671-4	6	
37	Washer, 3.2 Flat Zinc	F81050-2	6	
38	Screw, M3x8-4.8 Zinc	F81000-83	6	
39	Switch, SPST On/Off 15A .25 TABS Toggle	P03027	2	

¹ Use in African version only.

5.2 Control Box Bracket

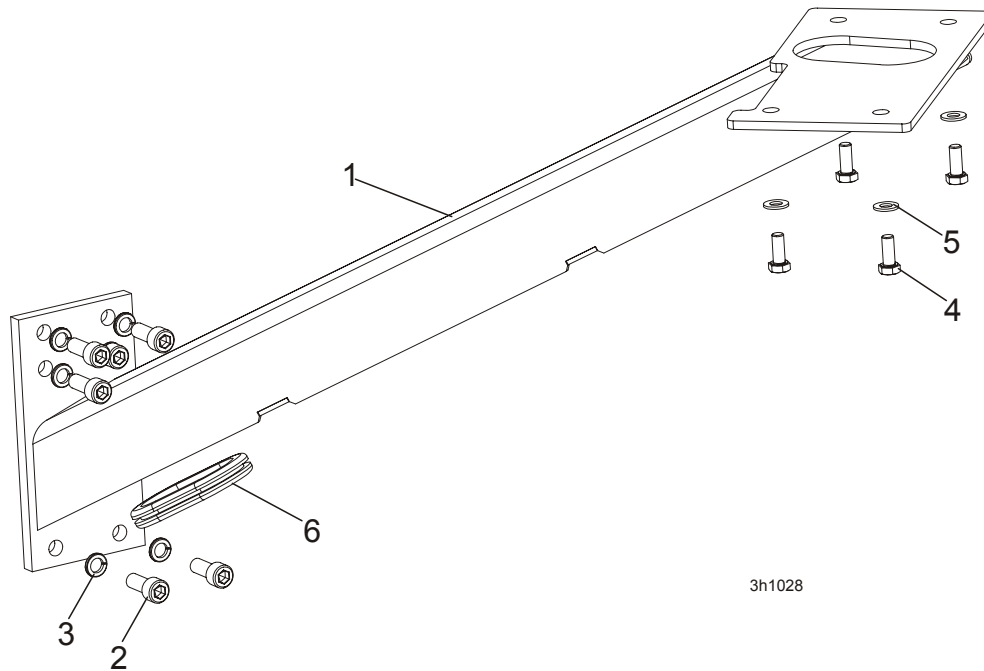

L.P.	OPIS (◆ wskazuje części dostępne jedynie w zespołach)	NUMER KAT.	SZT.	
1	MOUNT WELDMENT, STANDARD CONTROL BOX	086732-1	1	
2	BOLT, M10x25 8.8 ZINC SOCKET HEAD	F81003-32	6	
3	WASHER, 10.2 SPLIT LOCK ZINC	F81055-2	6	
4	BOLT, M8X20MM HEX HEAD, GR 5.8 ZINC	F81002-4	4	
5	WASHER, 8.4 FLAT ZINC	F81054-1	4	
6	GROMMET, RUBBER	087065	1	

5.3 Drum Switches

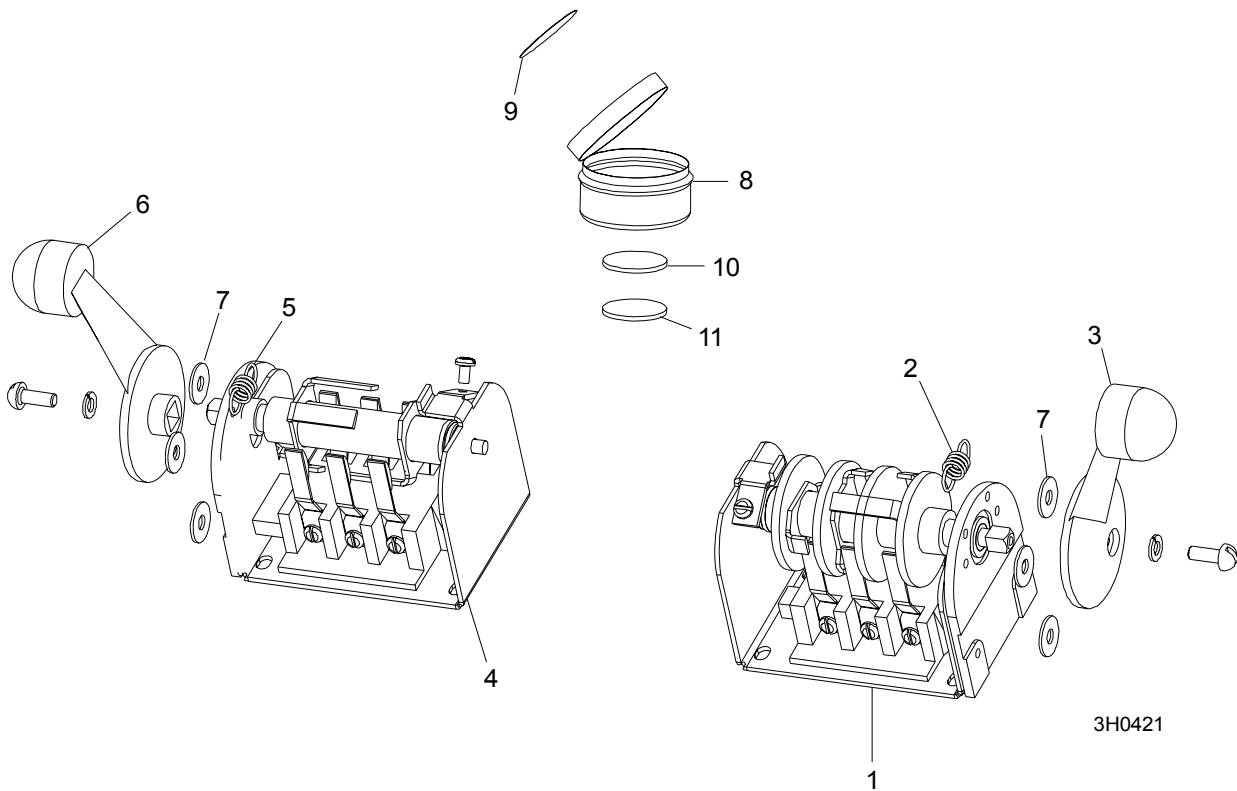

REF	DESCRIPTION (◆ Indicates Parts Available In Assemblies Only)	PART #	QTY.	
	SWITCH ASSEMBLY, UP/DOWN DRUM	E20440	1	
1	Switch, S12 Bulk Drum	E20440-B	1	◆
2	Spring, Drum Switch	P12570	1	
3	Handle, Drum Switch Replacement	P12500	1	
	SWITCH ASSEMBLY, POWER FEED DRUM	E20438	1	
4	Switch, S10 Bulk Drum	E20438-B	1	◆
5	Spring, Drum Switch	P12570	1	
6	Handle, Drum Switch Replacement	P12500	1	
7	WASHER, #8 SAE FLAT	F05011-41	6	
	CUP ASSEMBLY, DRUM SWITCH GREASE	A20463	1	
8	Cup, Plastic Container	P20464	1	◆
9	Decal, Grease Cup Label	P20467	1	
10	Pad, Velcro Loop	P20466	1	◆
11	Pad, Velcro Hook	P20465	1	◆
	Grease, High Temp Drum Switch	P20468	.011ml	◆

5.4 Circuit Breakers

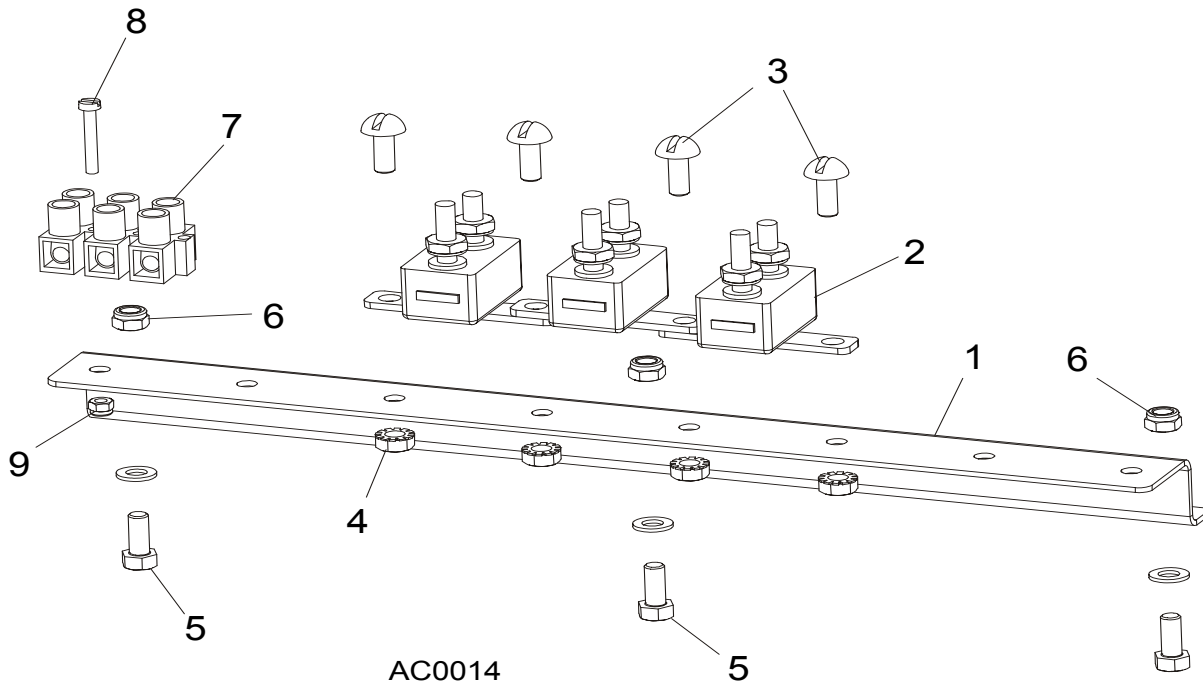

REF	DESCRIPTION (◆ Indicates Parts Available In Assemblies Only)	PART #	QTY.
1	RAIL, CIRCUIT BREAKER	015310	1
2	BREAKER, 15 AMP MANUAL RESET	E20430	5
3	SCREW, H M5X10 8.8 ZINC	F81000-13	4
4	NUT, M5-8 ZINC HEX SELF-LOCKING	F81030-2	4
5	SCREW, M5X12-5.8 ZINC	F81000-5	3
6	NUT, M5-8 ZINC HEX SELF-LOCKING	F81030-2	3
7	STRIP, ELECTRIC WIRE	F81086-1	1
8	SCREW, M3 X 20-5.8	F81000-8	1
9	NUT, M3	F81028-2	1

SECTION 6 UP/DOWN SYSTEM

6.1 Saw Head V-Brace Mount

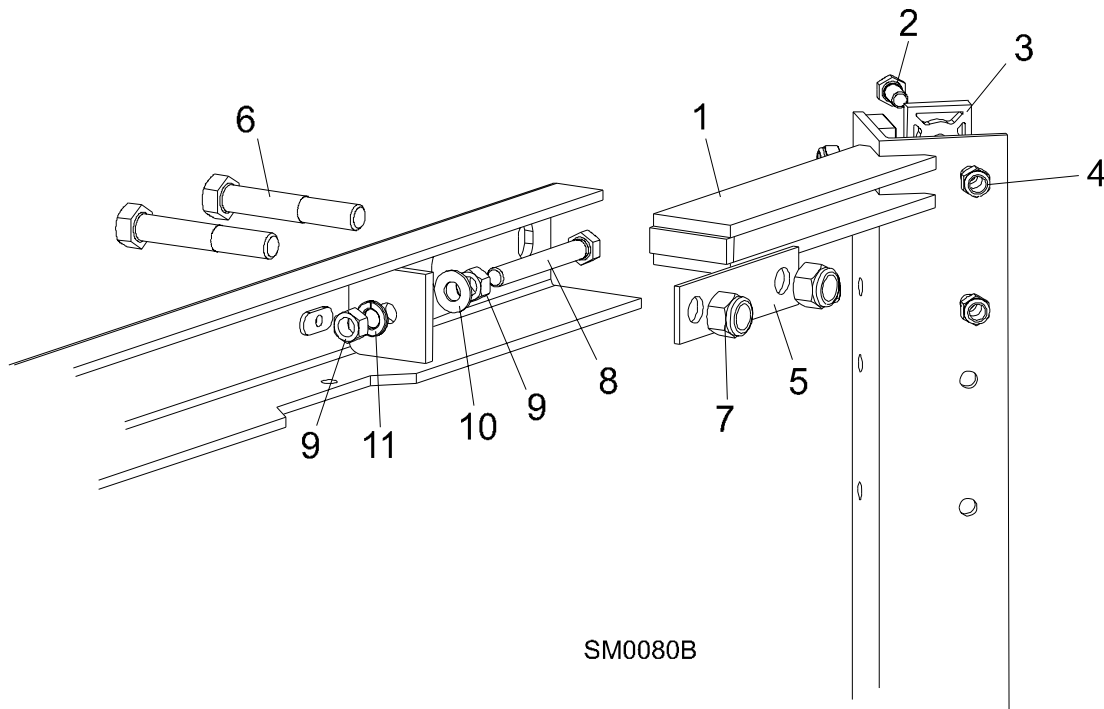

SM0080B

REF	DESCRIPTION (◆ Indicates Parts Available In Assemblies Only)	PART #	QTY.
1	V-BRACE, SAW HEAD MOUNT	086308	1
2	BOLT, 5/16-18 X 3/4" HEX HEAD GRADE 5	F05006-5	19
	BOLT, 5/16-18 X 1 1/4" HEX HEAD FULL THREAD	F05006-18	5
3	PAD, PLASTIC SLIDE	M04096	12
4	NUT, 5/16-18 NYLON LOCK	F05010-58	19
	NUT, 5/16-18 HEX	F05010-17	5
5	PLATE, V-BRACE WASHER	091247	4
6	BOLT, M12 X 40 - 8.8 HEX HEAD	F81004-1	4
7	NUT, M12 - 8 NYLON LOCK	F81034-2	4
8	BOLT, 3/8-16 X 3" FULL THREAD	F05007-1	2
9	NUT, 3/8-16 HEX	F05010-1	4
10	WASHER, 10.5 FLAT	F81055-1	2
11	WASHER, 10.2 SPLIT LOCK	F81055-2	2

6.2 Blade Height Scale

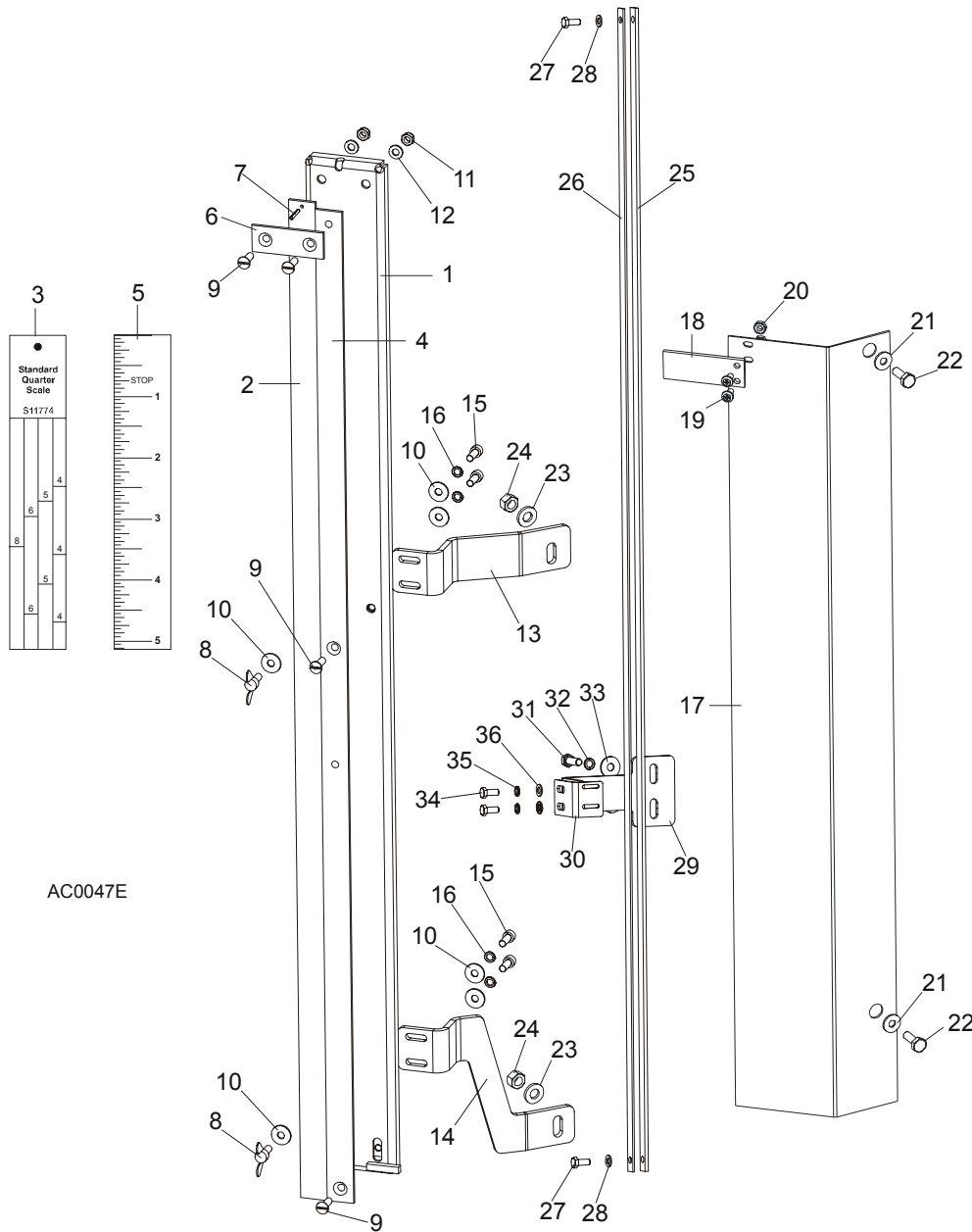

REF	DESCRIPTION (◆ Indicates Parts Available In Assemblies Only)	PART #	QTY.
	SCALE, BLADE HEIGHT W/SCANNER	098882	1
1	Bracket, Scale Mounting	098890-1	1
2	Scale, 35" Quarter	093342	1
3	Decal, 35" Standard Quarter Scale	090716	1
	Decal, 35" Grade Hardwood Quarter Scale	090717	1
4	Scale, 35" Inch	093341	1
5	Decal, 35" Inch	090709	1
6	Strap, Scale Hold-Down	093134	1
7	Pin, 3x20 Roll	F81044-5	1
8	Screw, M6x16 Wing	F81001-16	2
9	Screw, M6x20- 4.8-B	F81001-31	4

10	Washer, 6.5 Flat	F81053-11	7	
11	Nut, M6, Hex, Nylon Lock Zinc	F81031-2	2	
12	Washer, M6, Flat, Zinc	F81053-1	2	
13	Bracket, Scale Upper	098880-1	1	
14	Bracket, Scale Lower	098881-1	1	
15	Bolt, M6x16-8.8 Socket Head	F81001-21	4	
16	Washer, M6 Split Lock Zinc	F81053-3	4	
	Pointer Assembly, Fixed Scale	A12023	1	
17	Bracket, Fixed Scale Pointer Mount	087044-1	1	◆
18	Indicator, Blade Height Scale	094821	1	
19	Screw, M4x12 -5,8-B- Fe/Zn5	F81011-43	2	
20	Nut, M4-B Fe/Zn5	F81029-1	2	
21	Washer, 6.5 Flat	F81053-11	2	
22	Bolt, M6x12-8.8-Zinc	F81001-7	2	
23	Washer, 8.4 Flat	F81054-1	2	
24	Nut, M8-8-B Hex Lock	F81032-2	2	
	MAGNETIC STRIP ASSY	097774	1	
	Bar with Magnetic Strip	098173-1	1	
25	Magnetic Strip MB320 (1m)	096014-1	1	
26	Bar, Magnetic Strip	098173	1	
27	Bolt, M5 X 12-5.8-Fe/Zn5	F81000-5	2	
28	Washer, M5, Flat zinc	F81052-1	2	
	BRACKET, SENSOR COMPLETE	100620	1	
29	Bracket, Sensor	100599-1	1	
30	Bracket, Sensor	100619-1	1	
31	Bolt, M6x20-8.8 Hex Head Full Thread Zinc	F81001-2	2	
32	Washer, Z6.1 Split Lock Zinc	F81053-3	2	
33	Washer, 6.5 Flat Zinc	F81053-11	2	
34	Bolt, M5 X 12-5.8-Fe/Zn5, PN-M/82105	F81000-5	2	
35	Washer, 5.1 Split Lock Zinc	F81052-2	2	
36	Washer, 5.3 Flat Zinc	F81052-1	2	
	DECAL KIT, METRIC SCALE	K12064	1	
	Decal, Metric	S11711	1	
	Decal, Metric 16-40mm	P12040-1	1	
	Decal, Metric 45-63mm	P12040-2	1	

6.3 Up/Down Chain & Sprockets

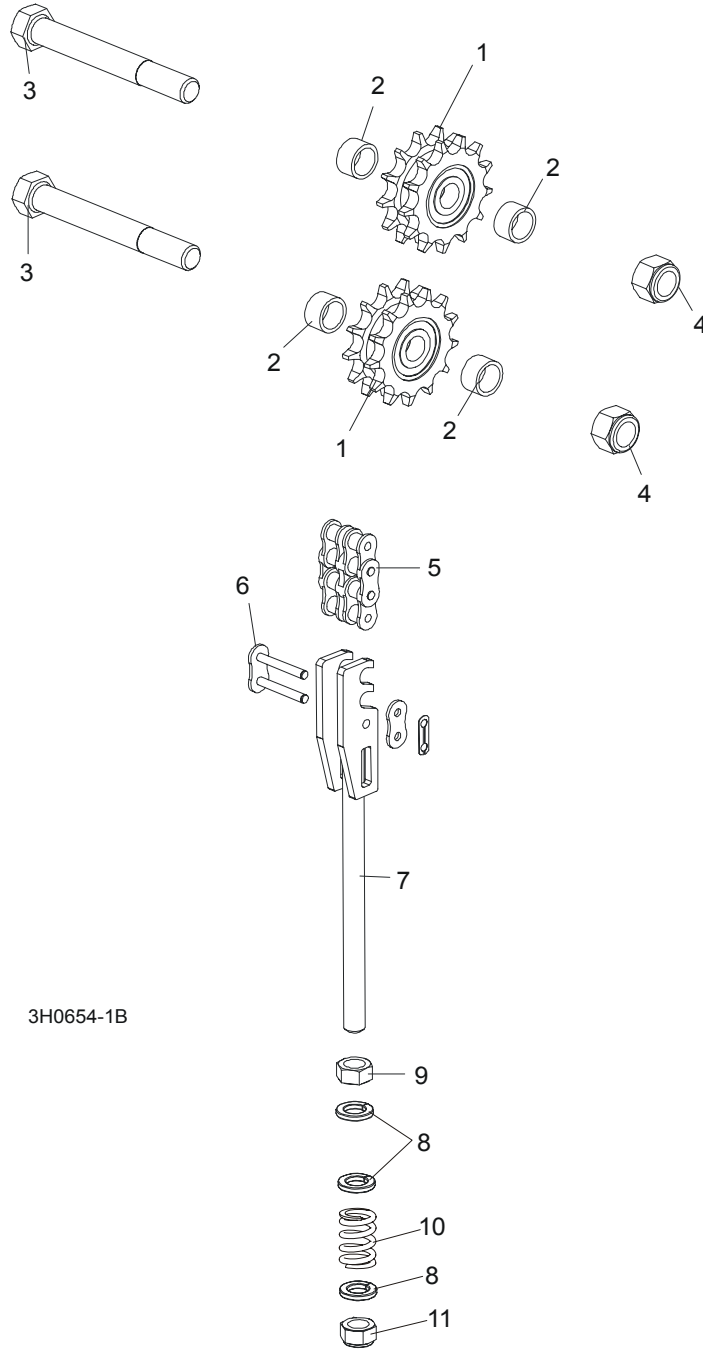

REF	DESCRIPTION (◆ Indicates Parts Available In Assemblies Only)	PART #	QTY.
	SPROCKET KIT, UP/DOWN IDLER #50-2	016020	1
1	Sprocket, Up/Down Idler '98	016019	2
2	Washer, Sprocket Spacer	095927-1	4
	Instruction Sheet, Up/Down Idler Retrofit	016020-541	1
3	BOLT, 5/8-11 X 5" HEX HEAD GRADE 2	F05009-6	2
4	NUT, 5/8-11 HEX NYLON LOCK	F05010-34	2
5	CHAIN, #50-2 X 75.625" UP/DOWN	015259	1
6	LINK, #50-2 MASTER	015258	2
	TENSIONER ASSEMBLY, UP/DOWN CHAIN	094283	1

7	Bracket, Up/Down Chain Tensioner	094281-1	1	◆
8	Washer, M12, Flat, Zinc	F81056-1	3	
9	Nut, M12-8-B Hex	F81034-1	1	
10	Spring, 14x30x3.2	090797	1	
11	Nut, M12, Hexagon, Nylon, Zinc, Lock	F81034-2	1	

6.4 Up/Down Motor Assembly, LT40 Series AH

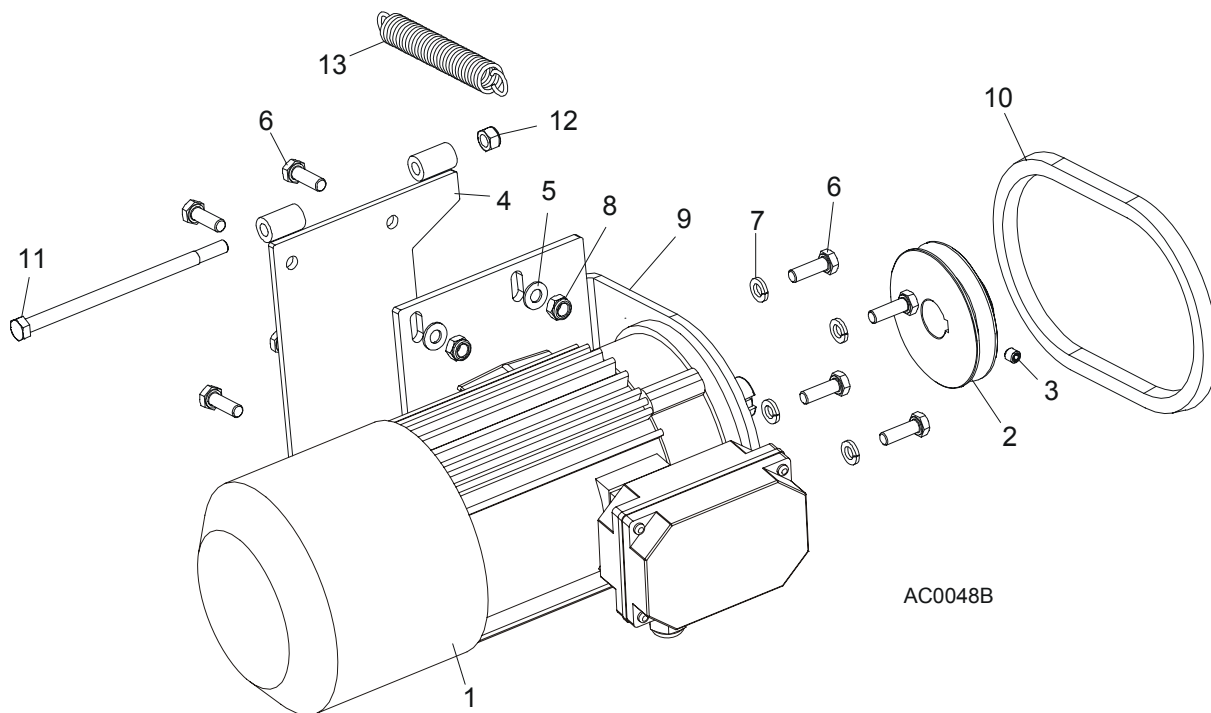

REF	DESCRIPTION (◆ Indicates Parts Available In Assemblies Only)	PART #	QTY.
	UP/DOWN MOTOR ASSEMBLY, LT40AC	093023	1
1	Motor, SKh90-4S2 HPS 1,1kW, 1380obr./min 400V (w/brake)	098901	1
2	Pulley, AC Up/Down Motor Painted	086378-1	1
3	Screw, M8 x 8-33H Hex Socket Set Flat Point Zinc	F81014-1	1
4	Bracket Wdmt, Up/Down Motor	095738-1	1
5	Washer, 8.4 Split Lock	F81054-1	4
6	Bolt, M8 x 25 8.8 B Hex Head	F81002-4	8
7	Washer, 8.2 Split Lock	F81054-4	4
8	Nut, M8 8 B Hex	F81032-2	4
9	Bracket, AC Up/Down Motor Mount	086376-1	1
10	BELT, AX23	015257	1
11	BOLT, M8X160-8.8-B ZINC	F81002-22	1
12	NUT, M8-8-B NYLON LOCK HEX ZINC	F81032-2	1
13	SPRING, 3/4x 5x.095 EXTENSION	015569	1

6.5 Up/Down Drive Assembly

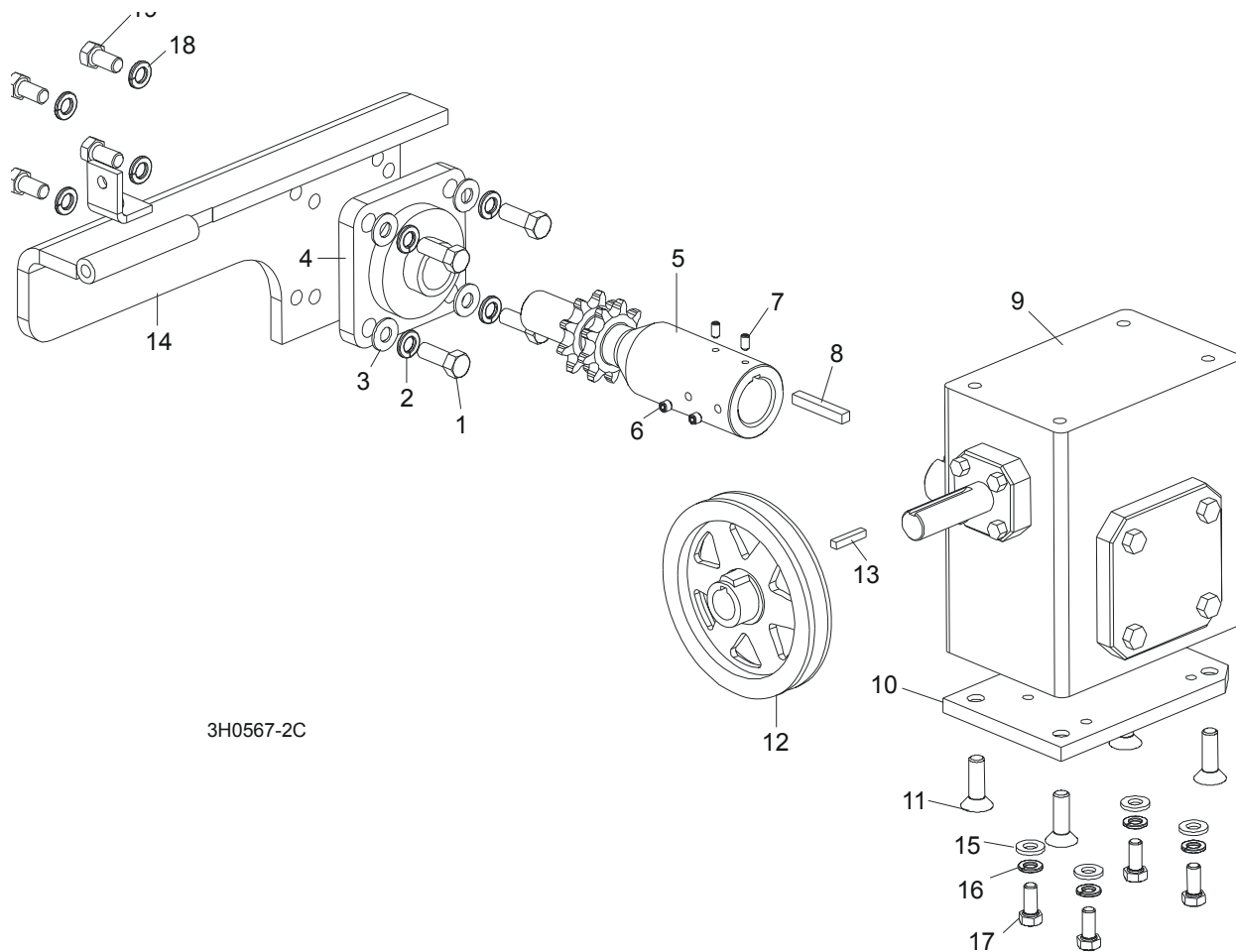

3H0567-2C

REF	DESCRIPTION (◆ Indicates Parts Available In Assemblies Only)	PART #	QTY.
	UP/DOWN DRIVE ASSEMBLY	092817	1
1	Bolt, 3/8-16 x 1" Hex Head	F05007-7	4
2	Washer, 10.2 Split Lock	F81055-2	4
3	Washer, 10.5 Flat	F81055-1	4
4	Bearing, Flanged Up/Down	014090	1
5	Shaft, Up/Down Sprocket	092816-1	1
6	Screw, M8 x 8-33H	F81014-1	2
7	Key, 1/4" Square x 1 11/16" Long	S04124	1
8	Spacer, Up/Down Shaft	016032	1
9	Reducer, Gear Box	014074	1
10	Plate, Gear Box Spacer	095894-1	1
11	Bolt, 3/8-16 x 1" Flat Socket Head	F05007-110	4
12	Pulley, Up/Down	015256	1
13	Key, 3/16" Square x 1" Long	S31027	1
14	Bracket Wdmt, Up/Down Bearing	095893-1	1
15	WASHER, 8.4 FLAT	F81054-1	4
16	WASHER, 8.2 SPLIT LOCK	F81054-4	4
17	BOLT, 5/16-18 X 1" HEX HEAD	F05006-5	4

18	WASHER, 10.2 SPLIT LOCK	F81055-2	4	
19	BOLT, 3/8-16 X 3/4" HEX HEAD	F05007-27	4	
	OIL, 8 OZ. MOBIL SHC634 BOTTLED SYNTHETIC GEAR	L04869-4	1	

6.6 Safety Switches

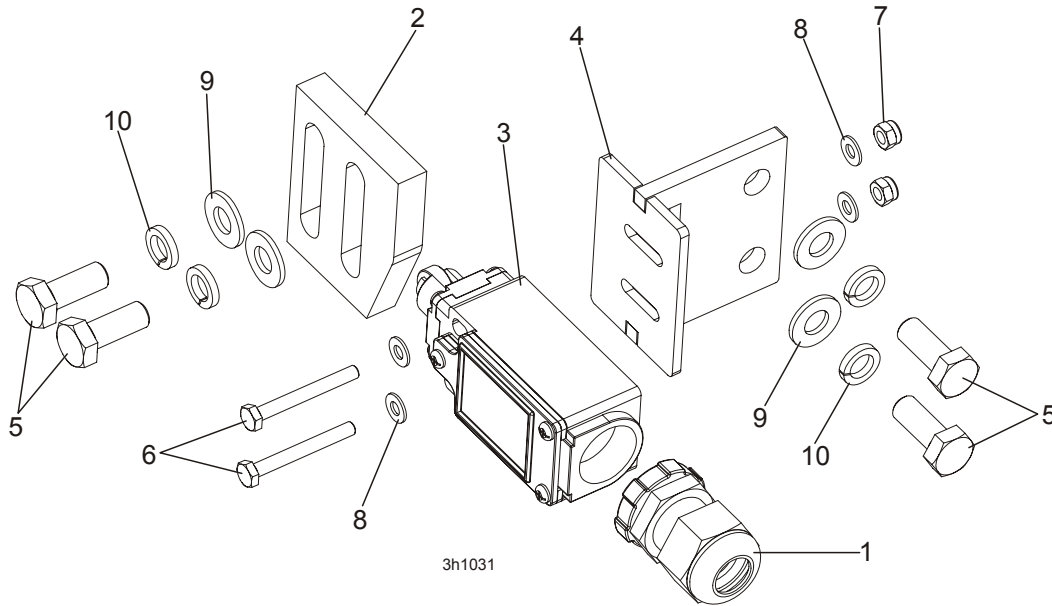

REF	DESCRIPTION (◆ Indicates Parts Available In Assemblies Only)	PART #	QTY.	
	KIT, LT40 UP/DOWN LOWER SAFETY SWITCH	504038	1	
1	STUFFING-BOX, SKINTOP PG 13,5	086524	1	
2	CAM, LIMIT SWITCH	094229-1	1	
3	SWITCH, GLCB01C LIMIT	100910	1	
4	BRACKET, LT40 LOWER SAFETY SWITCH	504035-1	1	
5	BOLT, M8x20-8.8-B HEX HEAD FULL THREAD	F81002-4	4	
6	BOLT, M4x35-8.8 SOCKET HEAD ZINC	F81011-7	2	
7	NUT, M4-B FE/ZN5 PN-M/82175	F81029-1	2	
8	WASHER, 4.3 FE/ZN5 PN-M/82005	F81051-2	4	
9	WASHER, 8.4 FLAT ZINC	F81054-1	4	
10	WASHER, 8.2 SPLIT LOCK ZINC	F81054-4	4	

SECTION 7 POWER FEED & TRACK ROLLERS

7.1 Upper Track Rollers And Wipers

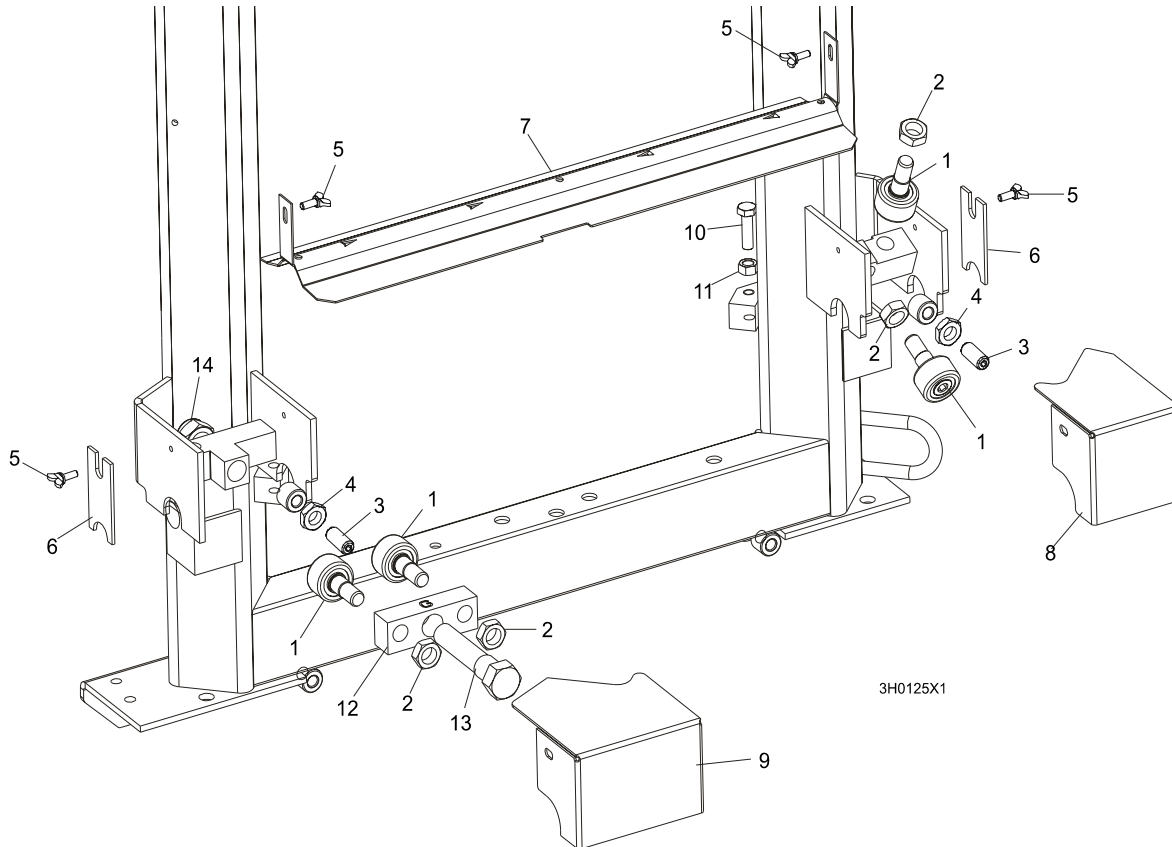

REF	DESCRIPTION (◆ Indicates Parts Available In Assemblies Only)	PART #	QTY.
1	ROLLER, TRACK CAM BEARING	P12843	4
2	NUT, 5/8-18 HEX JAM	F05010-11	4
3	SCREW, M12 X 30 OVAL POINT SET	F81004-14	2
4	NUT, M12-8-B HEX JAM	F81034-1	2
5	SCREW, M6 X 16 THUMB	F81001-16	4
6	WIPER, PLASTIC TRACK	M04113	2
7	COVER, LT40/70 MIDDLE TRACK - SERVICE	092868-S	1
	Cover, LT40/70 Middle Track Ptd	092868-1	1
	Strip, 3/16 X 2 X 23 Felt	S09915	1
8	HOUSING, UPPER TRACK ROLLER REAR	086913-1	1
9	HOUSING, UPPER TRACK ROLLER FRONT	086914-1	1
10	BOLT, M10 X 35-8.8 HEX HEAD	F81003-17	2
11	NUT, M10-8 HEX JAM	F81033-3	2
12	BRACKET, UPPER TRACK ROLLER	086859-1	1
13	BOLT, HEX HEAD	086911	1
14	NUT, M20-8 HEX	F81037-2	1

7.2 Power Feed Assembly, LT40 Series AH

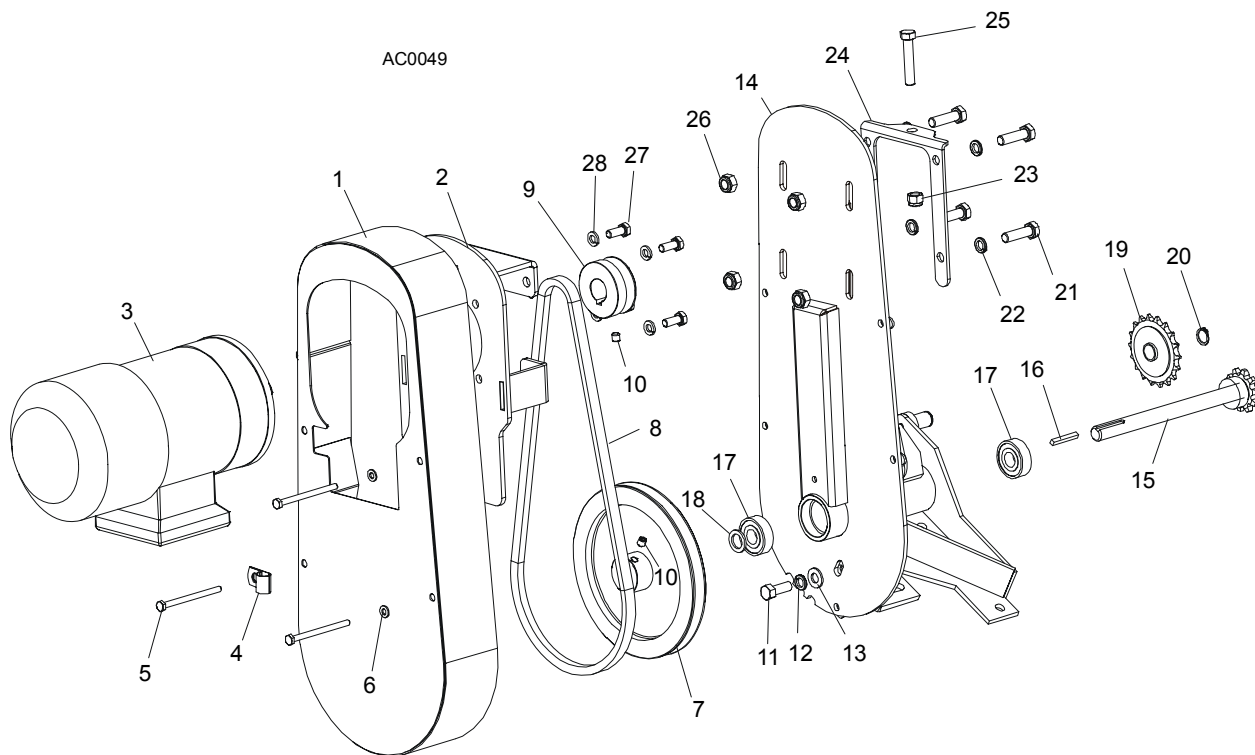

REF	DESCRIPTION (◆ Indicates Parts Available In Assemblies Only)	PART #	QTY.	
	POWER FEED ASSEMBLY, AC SUPER	086522	1	
1	Cover Weldment, Top Power Feed	015128	1	
2	Plate, Power Feed Motor	086390	1	
3	Motor, 1100 W Power Feed Painted, AC Super	086530	1	
4	Clamp, 1/2" EMT Coated	P07584	1	
5	Bolt, M6 x 80 5.8 Hex Head Grade	F81001-61	4	
6	Washer, 6.4 Flat	F81053-1	4	
7	Sheave, Power Feed	086410-1	1	
8	Belt, Power Feed	086532	1	
9	Sheave, Feed Motor	086388-1	1	
10	Screw, M8 X 8-33H Hex Socket Set Flat Point Zinc	F81014-1	2	
11	Bolt, 3/8-16 x 1" Hex Head	F05007-7	1	
12	Washer, 3/8" Split Lock	F05011-4	5	
13	Washer, 3/8" Flat	F05011-3	5	
14	Bracket, Power Feed Mount	015162	1	
15	Shaft Weldment, Power Feed	015129	1	
16	Key, 3/16" Square x 1 3/8" Long	016108	1	
17	Bearing, 6203-2RSP6-5/8 CX	095087	2	
18	Washer, 5/8" x 15/16" x .094" Nylon	F05011-19	1	
19	Sprocket, 40 Idler 18T 5/8" ID	P04333	1	
20	Ring, Z15	F81090-2	1	
21	Bolt, M10x35-8.8Hex Head Full Thread Zinc	F81003-17	4	
22	Washer, 10.2 Split Lock Zinc	F81055-2	1	◆
23	Nut, 3/8-16 Hex Nylon Lock	F05010-10	1	

24	Bracket, Power Feed Mount	015162-1	1	
25	Bolt, 3/8-16 x 2" Hex Head Full Thread Zinc	F05007-16	1	
26	Nut, M10-8-B Hex Nylon Zinc Lock	F81033-1	1	
27	Bolt, M8x20-8.8-B Hex Head Full Thread Zinc	F81002-4	4	
28	Washer, 8.2 Split Lock Zinc	F81054-4	4	

7.3 Feed Chain/Stop

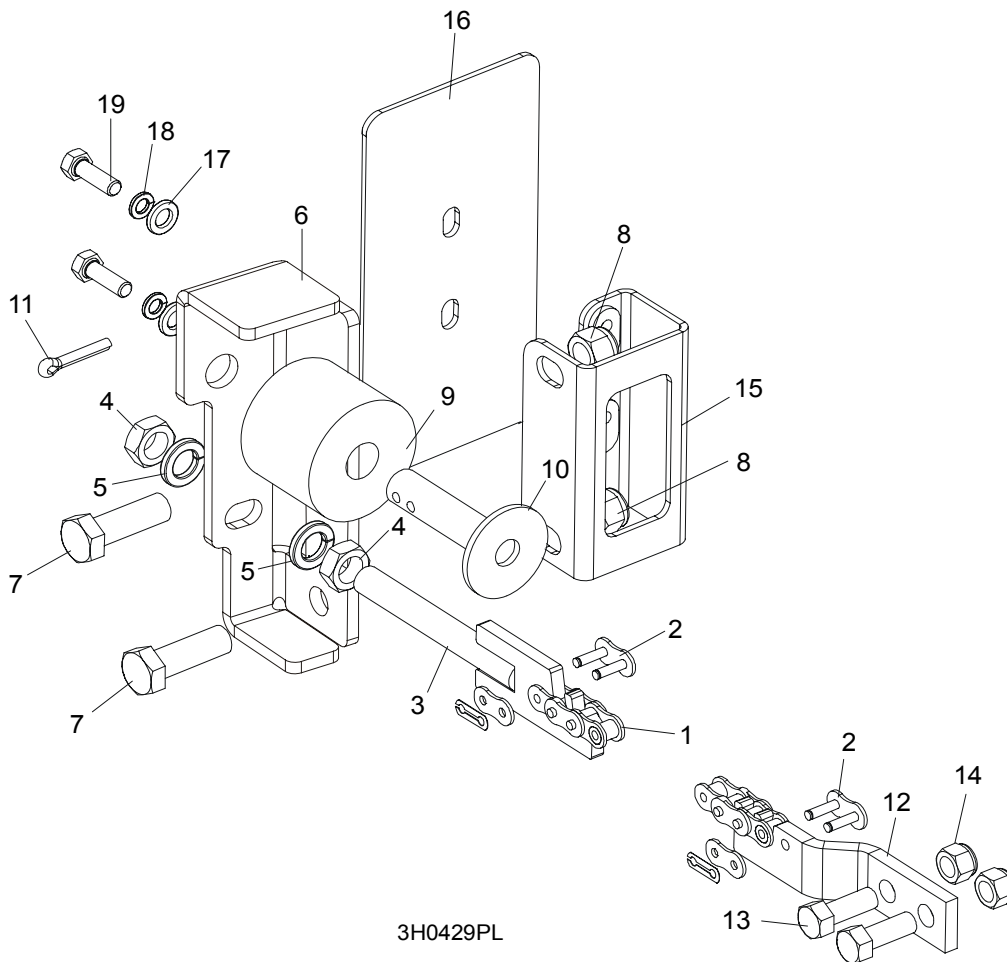

REF	DESCRIPTION (◆ Indicates Parts Available In Assemblies Only)	PART #	QTY.
	CHAIN KIT, LT30 FEED	K10408	1
	CHAIN KIT, LT40 FEED	K10410	1
1	Chain, #40 X 215" LT30 Feed	014744	1
	Chain, #40 X 267.5" LT40 Feed	014475	1
2	Link, #40 Master	P04200	2
3	Tensioner Weldment, Power Feed Chain	086818-1	1
4	Nut, M12-5 Hex Jam	F81034-4	2
5	Washer, 12.2 Split Lock	F81056-2	2
6	BRACKET, FEED CHAIN REAR MOUNT	087628-1	1
7	BOLT, M12 X 40 8.8 HEX HEAD GRADE 5	F81004-4	2
8	NUT, M12-8 HEX NYLON LOCK	F81034-2	2
	STOP KIT, RUBBER CARRIAGE	K09630	2
9	Stop, Rubber Carriage	P12165	1
10	Pin, Rubber Carriage Stop	W09293	1
11	Pin, 3/16" X 1" Cotter	F05012-21	1
12	BRACKET, FRONT FEED CHAIN MOUNT	095733-1	1
13	BOLT, 3/8-16 X 1" HEX HEAD	F05007-7	2
14	NUT, 3/8-16 HEX NYLON LOCK	F05010-10	2
15	BRACKET WELDMENT, REAR MAIN TUBE COVER MOUNT	087105-1	1

16	COVER, REAR MAIN TUBE	015023	1	
17	WASHER, 8.4 FLAT	F81054-1	2	
18	WASHER, 8.2 SPLIT LOCK	F81054-4	2	
19	BOLT, 5/16-18 X 1" HEX HEAD	F05006-1	2	

7.4 Lower Track Rollers

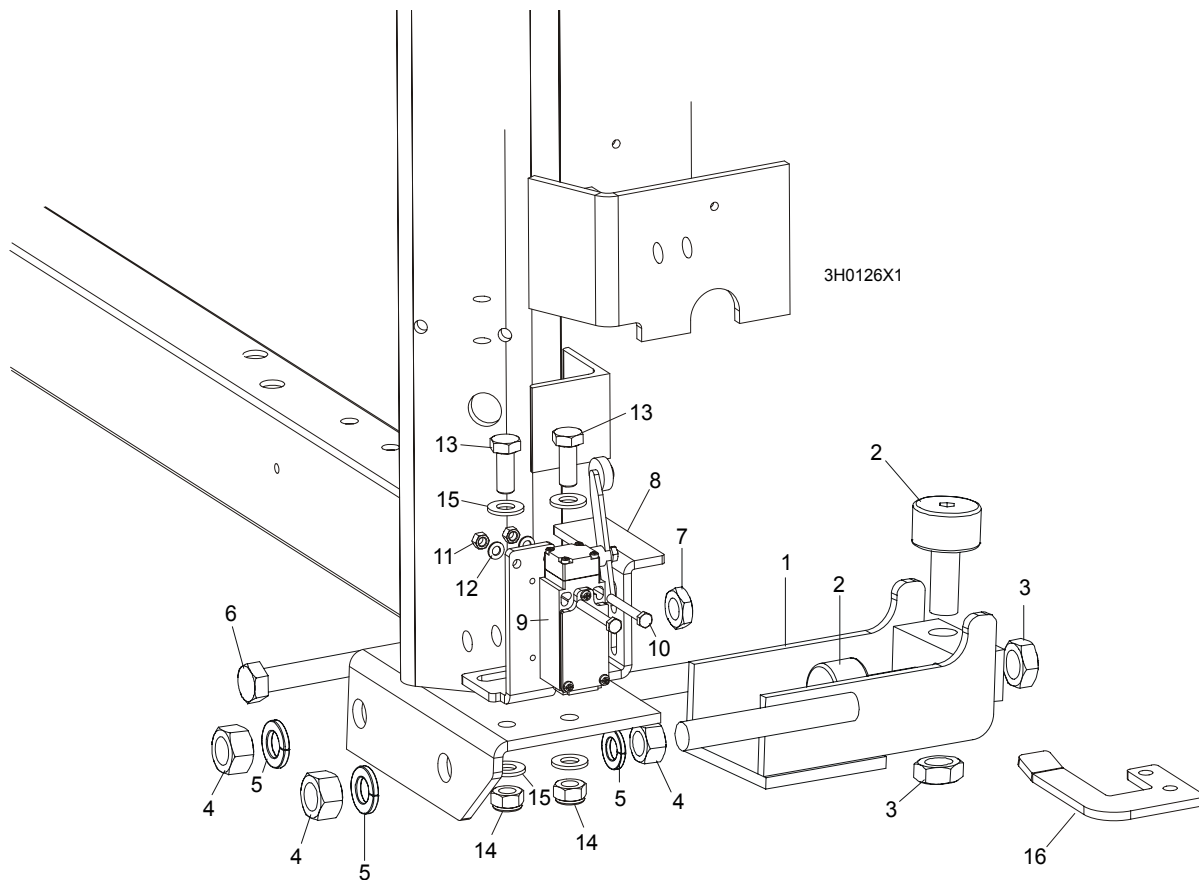

REF	DESCRIPTION (◆ Indicates Parts Available In Assemblies Only)	PART #	QTY.
	ROLLER ASSEMBLY, LOWER TRACK	098741	2
1	Bracket, Lower Track Roller Mounting	098740-1	1
2	Roller, Track Cam Bearing (McGill)	012797	2
3	Nut, 5/8-18 Hex Jam	F05010-11	2
4	Nut, M16, Hexagon, Grade 5.8 Plain	F81036-1	4
5	Washer, 16.3 Split Lock	F81058-2	4
6	BOLT, M12 X 55-8.8 HEX HEAD FULL THREAD	F81004-12	2
7	NUT, M12-8-B HEX JAM	F81034-1	2
8	BRACKET, POWER SUPPLY STRIP AND LIMIT SWITCH	086380-1	1
9	SWITCH, GLCB01A2B LIMIT	086469	1
10	BOLT, M5 X 40 8.8 HEX HEAD	F810000-11	2
11	NUT, M5-8	F81030-1	2
12	WASHER, 5.3 FLAT	F81052-1	2
13	BOLT, M10 X 25 8.8	F81003-11	2
14	NUT, M10 NYLON	F81033-1	2
15	WASHER, 10.5 FLAT	F81055-1	2
16	BRACKET, LIMIT SWITCH	091852-1	1

SECTION 8 BED FRAME ASSEMBLY

8.1 Bed Rail Assembly, Front

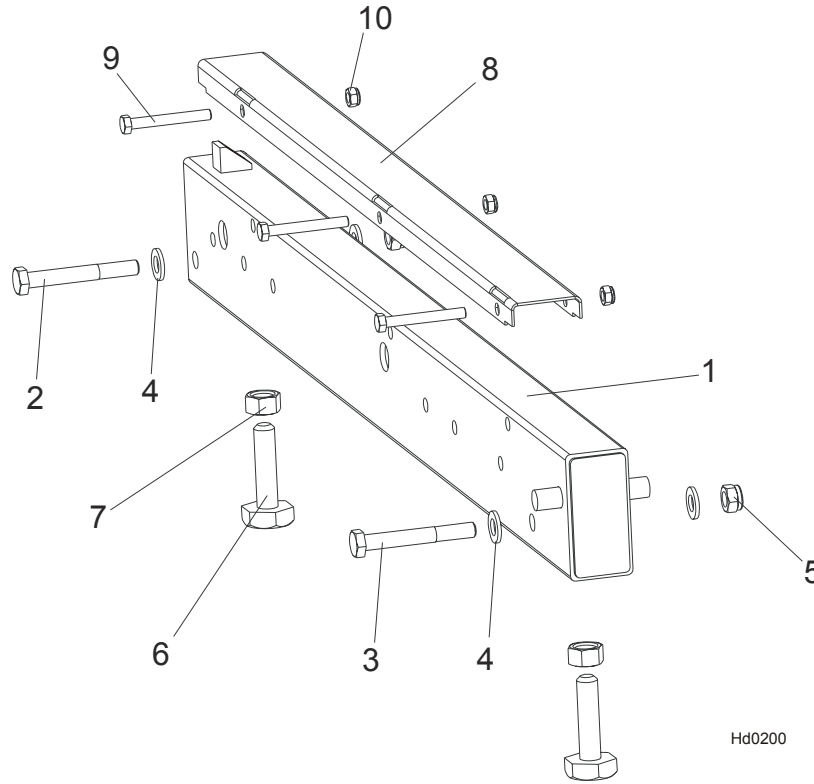

REF	DESCRIPTION (◆ Indicates Parts Available In Assemblies Only)	PART #	QTY.
1	BED RAIL ASSEMBLY, FRONT (S&M FRAME)	099955	1
2	Bolt, M12 x 90-8.8 Hex Head	F81004-2	1
3	Bolt, M12 x 95-8.8 Hex Head	F81004-29	1
4	Washer, 13 SAE Flat	F81056-1	4
5	Nut, M12-8 Hex Nylon Lock	F81034-2	2
	Bed Rail Bolt, Complete (M16 Bolt + 2xNut)	093710	2
6	Bolt, M16, Bed Rail Adjustment	086809	1
7	Nut, M16-5-B Zinc Hex Head	F81036-5	2
8	COVER, STAINLESS STEEL BED RAIL	099124	1
9	BOLT, M8X65-5,8 ZINC HEX HEAD	F81002-3	3
10	NUT, M8-8-B-ZINC HEX NYLON LOCK	F81032-2	3

8.2 Bed Rail Assembly, Rear

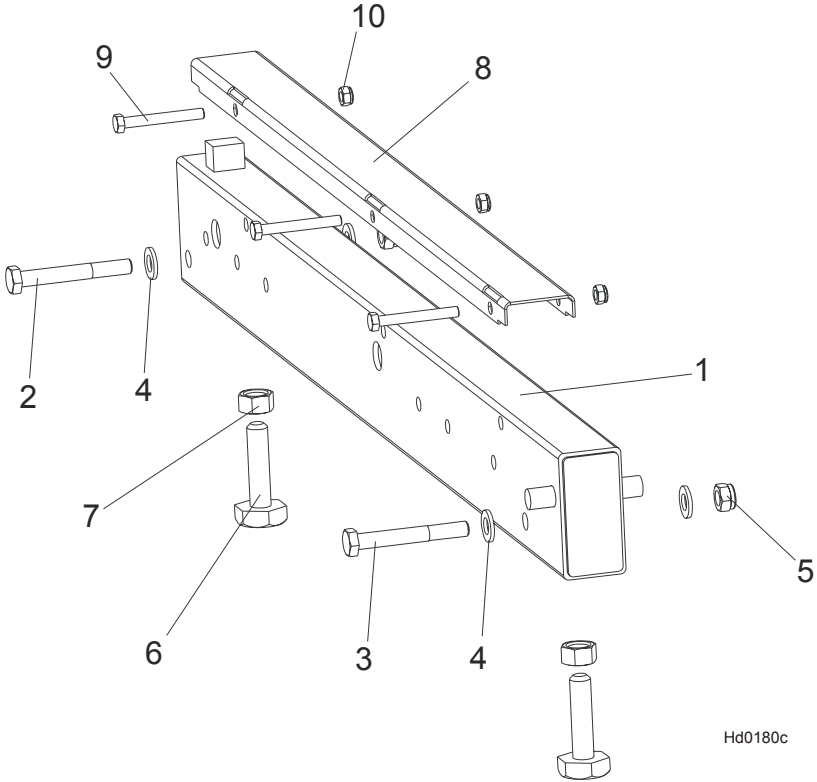

REF	DESCRIPTION (◆ Indicates Parts Available In Assemblies Only)	PART #	QTY.
1	BED RAIL ASSEMBLY, REAR PAINTED	091555	1
2	Bolt, M12 x 90-8.8 Hex Head	F81004-2	1
3	Bolt, M12 x 95-8.8 Hex Head	F81004-29	1
4	Washer, 13 SAE Flat	F81056-1	4
5	Nut, M12-8 Hex Nylon Lock	F81034-2	2
	Bed Rail Bolt, Complete (M16 Bolt + 2xNut)	093710	1
6	Bolt, M16, Bed Rail Adjustment	086809	1
7	Nut, M16-5-B Zinc Hex Head	F81036-5	2
8	COVER, STAINLESS STEEL BED RAIL	099124	1
9	BOLT, M8X65-5,8 ZINC HEX HEAD	F81002-3	3
10	NUT, M8-8-B-ZINC HEX NYLON LOCK	F81032-2	3

8.3 Bed Rail Assembly, Front Middle

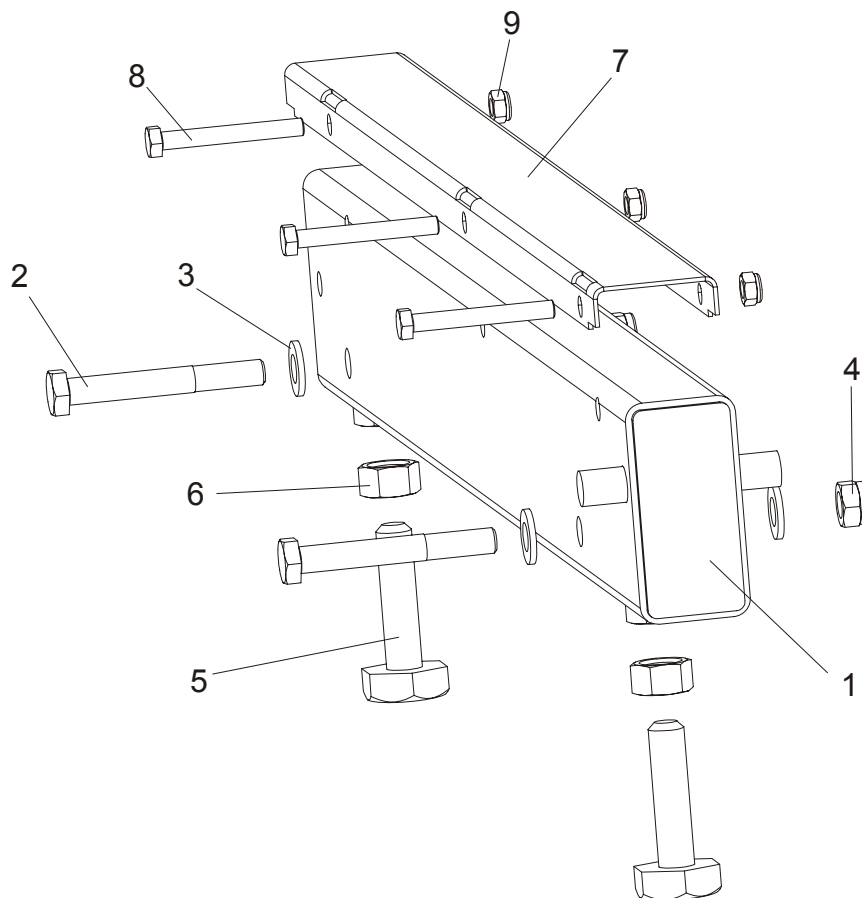

REF	DESCRIPTION (◆ Indicates Parts Available In Assemblies Only)	PART #	QTY.
1	BED RAIL ASSEMBLY, FRONT MIDDLE	091556	1
2	Bolt, M12 x 90-8.8 Hex Head	F81004-2	2
3	Washer, 13 SAE Flat	F81056-1	4
4	Nut, M12-8 hex Nylon Lock	F81034-2	2
	Bed Rail Bolt, Complete (M16 Bolt + 2xNut)	093710	2
5	Bolt, M16, Bed Rail Adjustment	086809	1
6	Nut, M16-5-B Zinc Hex Head	F81036-5	2
7	COVER, STAINLESS STEEL BED RAIL	099124	1
8	BOLT, M8X65-5,8 ZINC HEX HEAD	F81002-3	3
9	NUT, M8-8-B-ZINC HEX NYLON LOCK	F81032-2	3

8.4 Bed Rail Assembly, Rear Middle

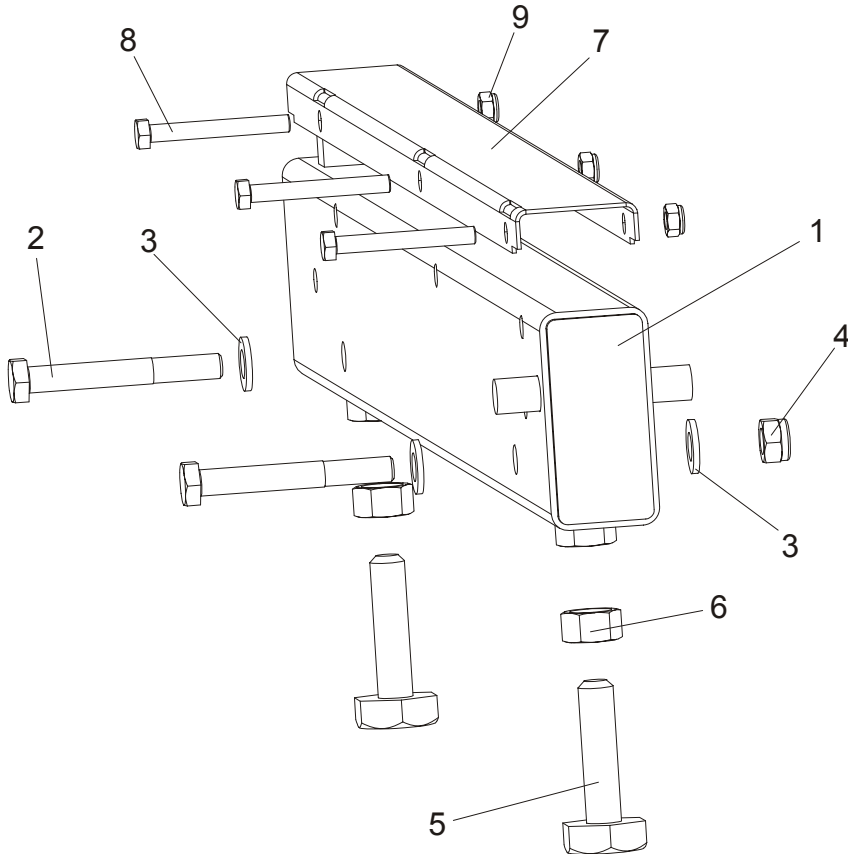

REF	DESCRIPTION (◆ Indicates Parts Available In Assemblies Only)	PART #	QTY.
1	BED RAIL ASSEMBLY, REAR MIDDLE PAINTED	091557	1
2	Bolt, M12 x 90-8.8 Hex Head	F81004-2	2
3	Washer, 13 SAE Flat	F81056-1	4
4	Nut, M12-8 hex Nylon Lock	F81034-2	2
	Bed Rail Bolt, Complete (M16 Bolt + 2xNut)	093710	2
5	Bolt, M16, Bed Rail Adjustment	086809	1
6	Nut, M16-5-B Hex	F81036-5	2
7	COVER, STAINLESS STEEL BED RAIL	099124	1
8	BOLT, M8X65-5,8 ZINC HEX HEAD	F81002-3	3
9	NUT, M8-8-B-ZINC HEX NYLON LOCK	F81032-2	3

8.5 Clamp Mount Assembly, Front (AH5/7)

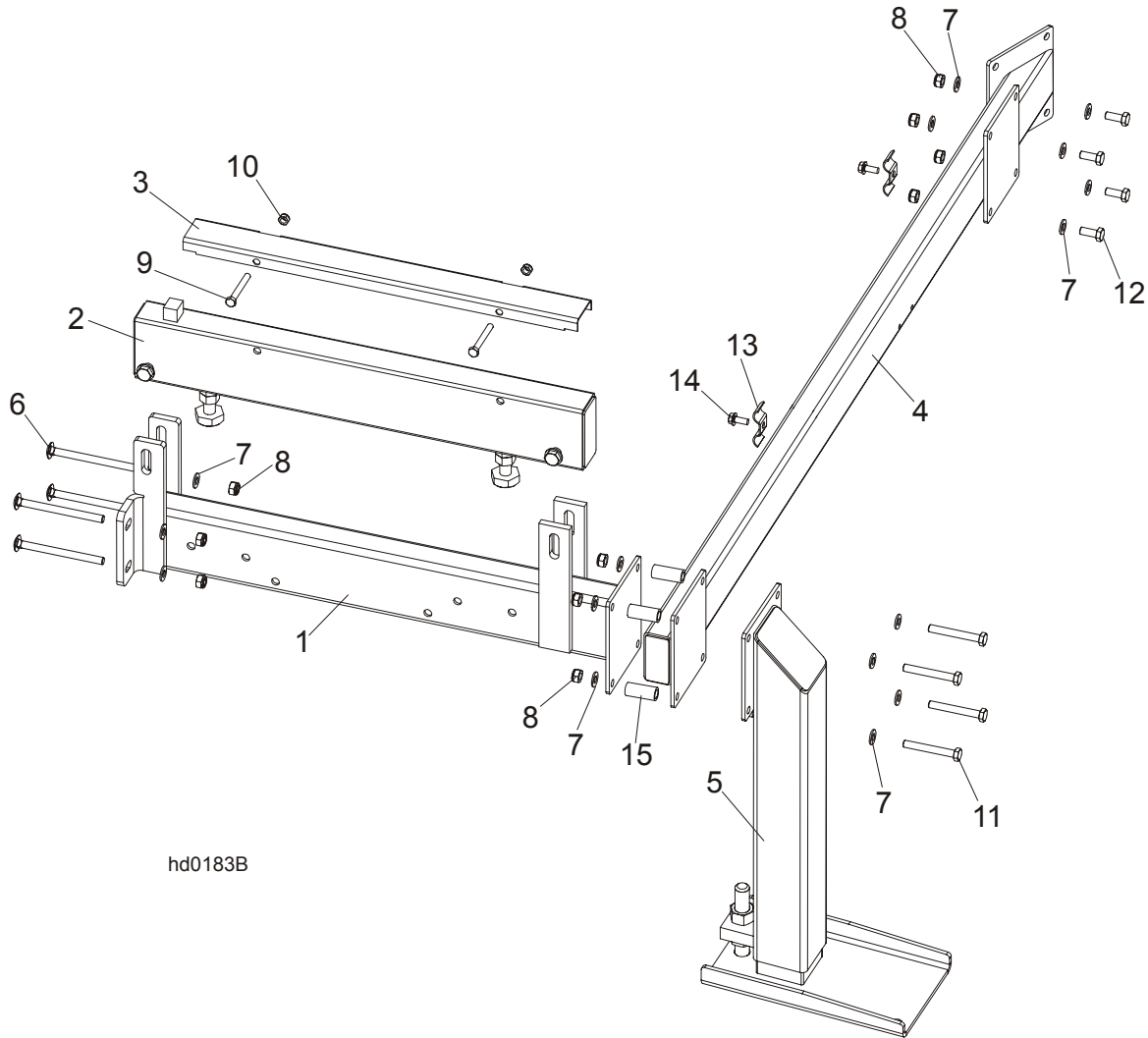

hd0183B

REF	DESCRIPTION (◆ Indicates Parts Available In Assemblies Only)	PART #	QTY.
	CLAMP MOUNT ASSEMBLY - FRONT	092937	1
1	Bed Rail Assembly, Front	092903-1	1
2	Bed Rail AH5/DH5	095131-1	1
3	Cover, 22.75 SS Pivot	099123	1
4	Tube Weldment, Bed Front	092904-1	1
5	Leg, Outrigger Stationary Left	501639	1
6	Bolt, M10 X 125-8.8 Carriage Head	F81003-34	4
7	Washer, Flat, M10, Zinc	F81055-1	20
8	Nut, M10, Nylon Hex Zinc Lock	F81033-1	12
9	Bolt, M8 x 65mm, HH, Grade 5.8, Zinc	F81002-3	2
10	Nut, M8, Hexagon, Nylon Lock Zinc	F81032-2	2
11	Bolt, M10x75-8.8-Fe/Zn5 PN-M/82101	F81003-15	4
12	Bolt, M10-1.5x25mm HH Gr 8.8	F81003-11	4
13	Plate, 1/4 Hose Clamp Ptd	S09245	2
14	Bolt, 5/16-18x3/4 Self Tap	F05015-30	2
15	Bushing, Zinc-Plated Spacer	095427-1	4

8.6 Clamp Mount Assembly, Rear (AH5/7)

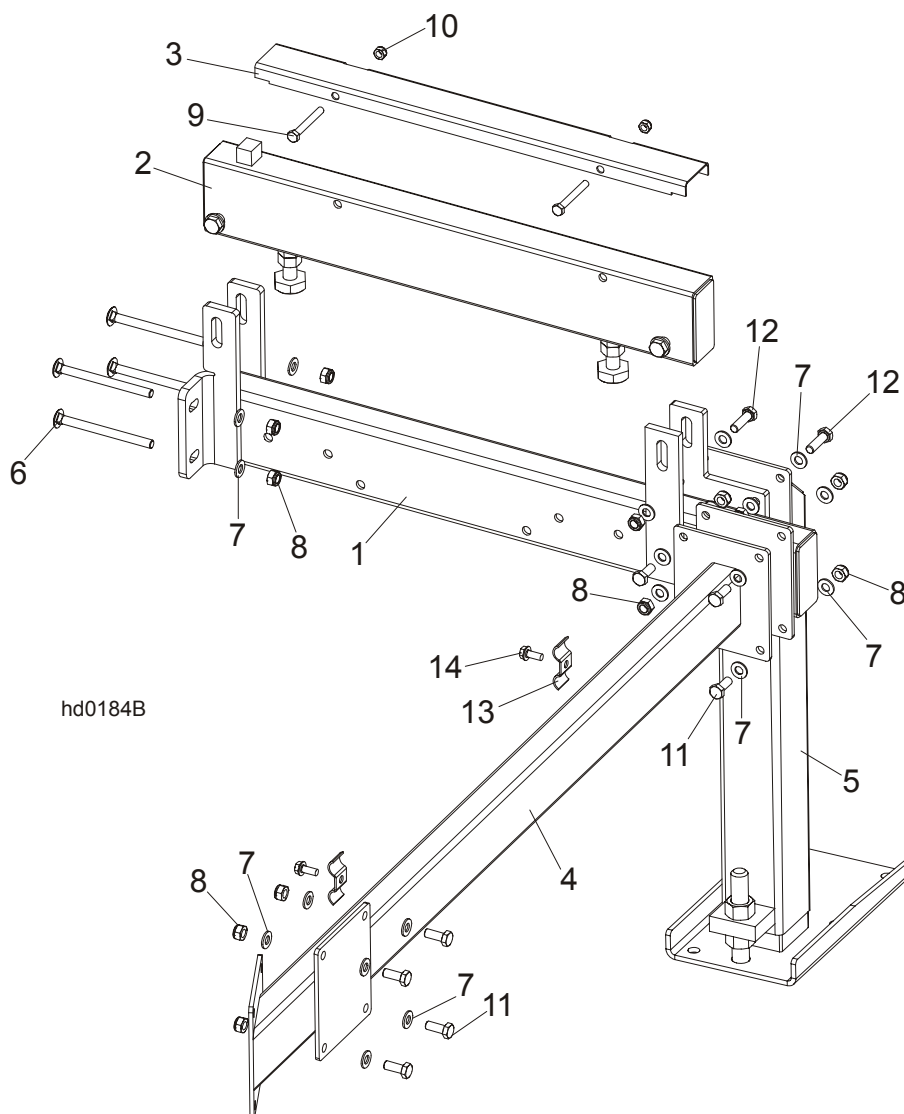

REF	DESCRIPTION (◆ Indicates Parts Available In Assemblies Only)	PART #	QTY.
	CLAMP MOUNT ASSEMBLY - REAR	092938	1
1	Bed Rail Assembly, Rear	092902-1	1
2	Bed Rail AH5/DH5	095131-1	1
3	Cover, 22.75 SS Pivot	099123	1
4	Tube Weldment, Bed Rear	092907-1	1
5	Leg, Outrigger Stationary Left	501639	1
6	Bolt, M10 X 125-8.8 Carriage Head	F81003-34	4
7	Washer, Flat, M10, Zinc	F81055-1	28
8	Nut, M10, Nylon Hex Zinc Lock	F81033-1	16
9	Bolt, M8 x 65mm, HH,Grade 5.8, Zinc	F81002-3	2
10	Nut, M8, Hexagon, Nylon Lock Zinc	F81032-2	2
11	Bolt, M10-1.5x25mm HH Gr 8.8	F81003-11	4
12	Bolt, M10x35mm HH Gr 8.8	F81003-17	4
13	Plate, 1/4 Hose Clamp Ptd	S09245	2
14	Bolt, 5/16-18x3/4 Self Tap	F05015-30	2

8.7 Leg, Stationary

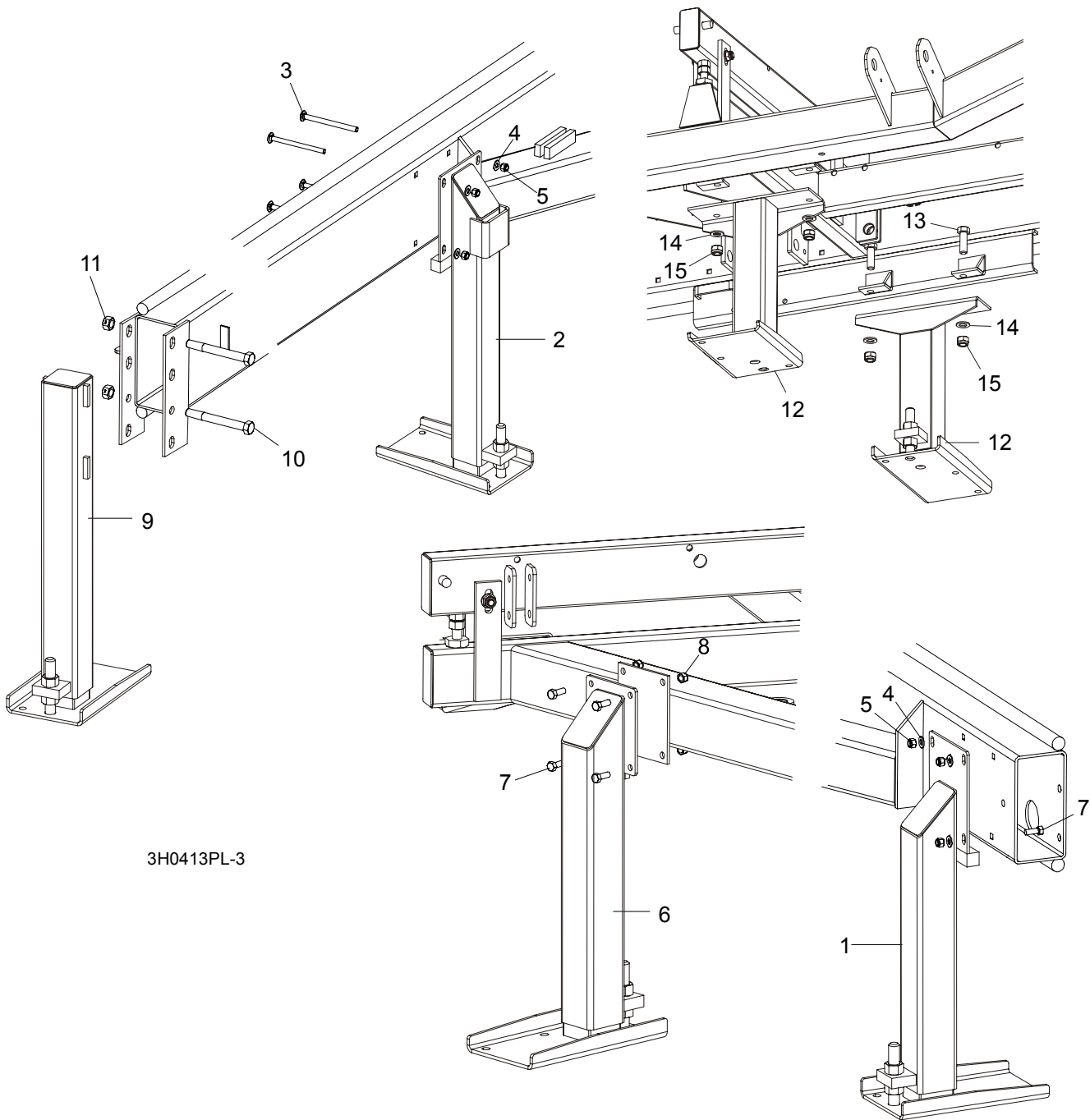

3H0413PL-3

REF	DESCRIPTION (◆ Indicates Parts Available In Assemblies Only)	PART #	QTY.
1	LEG, OUTRIGGER STATIONARY RIGHT (1 REQ'D FOR LT40SDH; 3 REQ'D FOR LT40MDH)	501640	1/3
2	LEG, OUTRIGGER STATIONARY W/BOARD RETURN TABLE BRACKET	501638	1
3	BOLT, M10 X 120-8.8 CARRIAGE HEAD	F81003-33	8/12
4	WASHER, 10.5 FLAT	F81055-1	8/16
5	NUT, M10-8-B HEX NYLON LOCK	F81033-1	8/16
6	LEG, OUTRIGGER STATIONARY LEFT	501639	2
7	BOLT, M10 X 25-8.8 HEX HEAD	F81003-11	12

8 Bed Frame Assembly

Leg, Stationary

8	NUT, M10-8-B HEX NYLON LOCK	F81033-1	12	
9	LEG, OUTRIGGER STATIONARY FRONT	501641	1	
10	BOLT, M16 X 140-8.8 HEX HEAD GRADE 5	F81006-4	2	
11	NUT, M16-8 HEX LOCK	F81036-2	2	
12	LEG, OUTRIGGER STATIONARY MIDDLE	501637	2	
13	BOLT, M16 X 50-8.8 HEX HEAD	F81006-7	4	
14	WASHER, 17 FLAT	F81058-1	4	
15	NUT, M16 NYLON LOCK	F81036-2	4	

8.8 Table, M Frame Sawmill with A/DH1-3 Hydraulics (option)

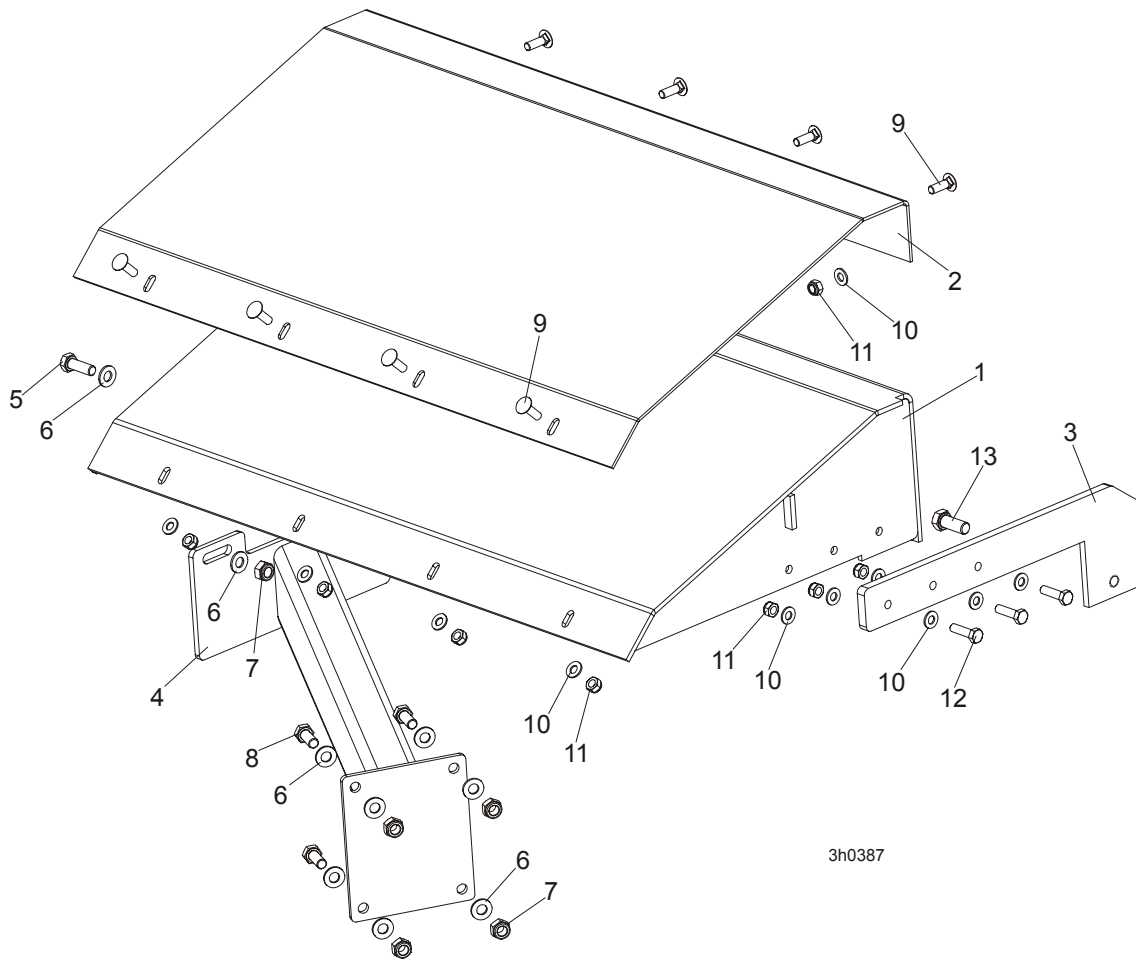

3h0387

REF	DESCRIPTION (◆ Indicates Parts Available In Assemblies Only)	PART #	QTY.
	BOARD RETURN LT40M (A/DH1-3) - COMPLETE	100660	1
	BOARD RETURN ASSEMBLY See Section 4.3	087839-1	1
	TABLE, M FRAME COMPLETE	099939	1
1	Table, M Frame	100672-1	1
2	Plate, M Frame Table	099946	1
3	Plate, Table Right	099945-1	1
4	Bracket, M Frame Table Support	099941-1	1
5	BOLT, M10X30-5.8 HEX HEAD FULL THREAD	F81003-2	2
6	WASHER, 10.5 FLAT ZINC	F81055-1	12
7	NUT, M10-8-B NYLON HEX ZINC LOCK	F81033-1	6
8	Bolt, M10-1.5x25mm HH Gr8.8	F81003-11	4
9	Bolt, M8x20mm HH Gr8.8	F81002-11	8
10	WASHER, 8.4 FLAT, ZINC	F81054-1	14
11	NUT, M8-8-B, HEX, NYLON LOCK ZINC	F81032-2	11
12	BOLT, M8x30mm, HH, GR 5.8, FULL THRD, ZINC	F81002-2	1
13	BOLT M12x30-8.8	F81004-22	1

8.9 Table, M Frame Sawmill with A/DH4-7 Hydraulics (option)

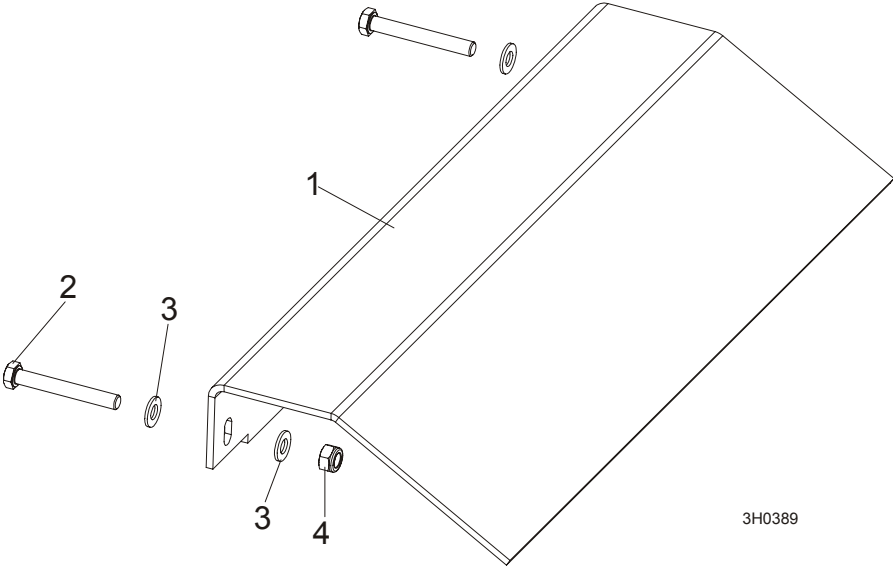

REF	DESCRIPTION (◆ Indicates Parts Available In Assemblies Only)	PART #	QTY.	
	BOARD RETURN LT40M (A/DH4-7) - COMPLETE	100703	1	
	BOARD RETURN ASSEMBLY See Section 4.3	087839-1	1	
1	PLATE, BOARD RETURN ASSY	099953-1	1	
2	BOLT, M10x75-8.8-Fe/Zn5 PN-M/82101	F81003-15	2	
3	WASHER, 10.5 FLAT ZINC	F81055-1	4	
4	NUT, M10-8-B NYLON HEX ZINC LOCK	F81033-1	2	

8.10 Board Return Table, Stationary "M" Frame Option

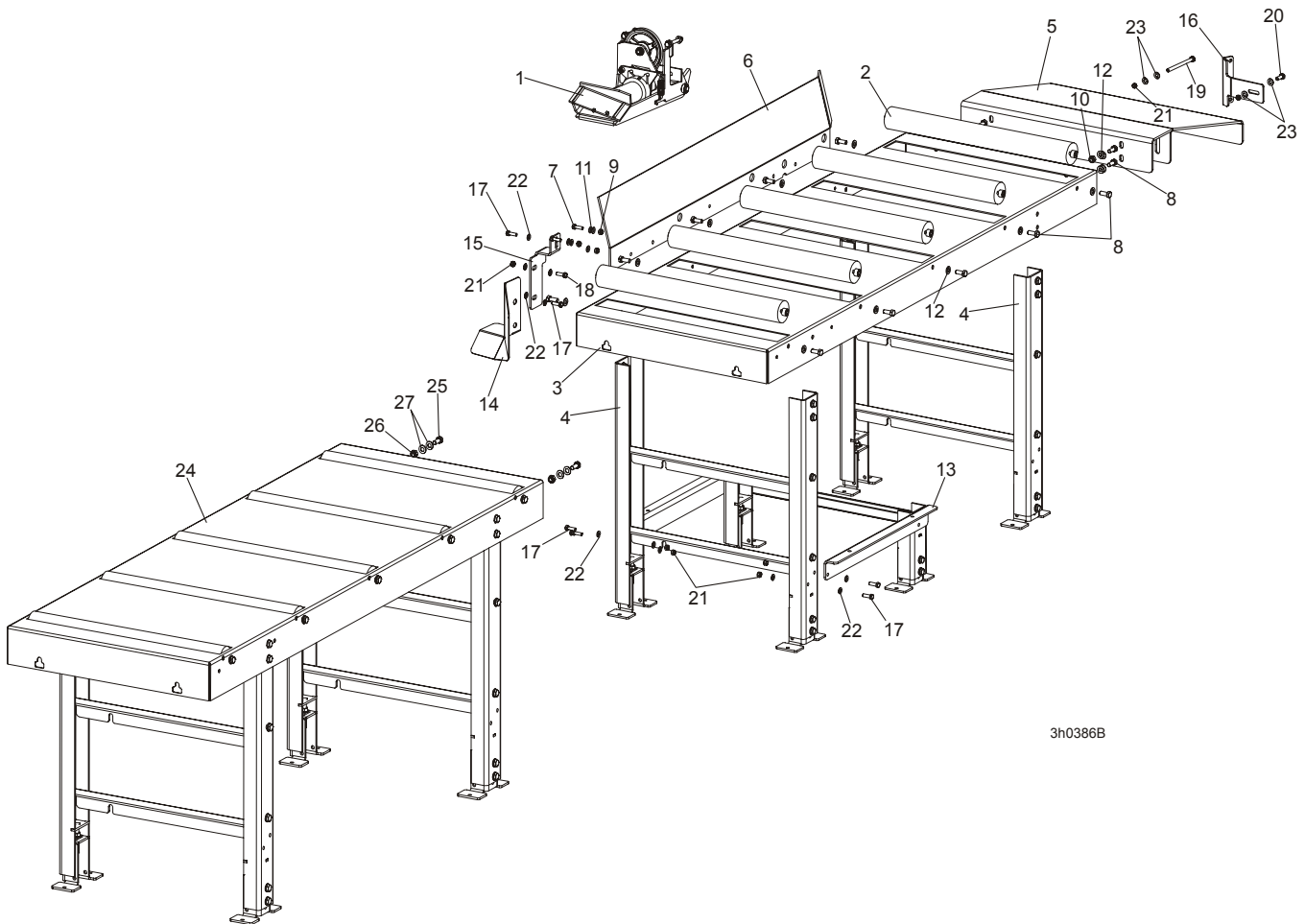

3h0386B

REF	DESCRIPTION (◆ Indicates Parts Available In Assemblies Only)	PART #	QTY.
	TABLE, LT40M DOUBLE	502789	1
	BOARD RETURN TABLE - LT40M LONG TABLE	502530	1
1	BOARD RETURN ASSEMBLY See Section 4.3	087839-1	1
	TABLE, "M" FRAME LONG SPECIAL	501975	1
2	ROLLER, 63.5/20x600 (EDGER) PTD.	500077-1	5
3	TABLE, EDGER	500078-1	1
4	LEG, BOARD RETURN TABLE	501974	2
5	PLATE, BOARD RETURN TABLE FRONT	501977-1	1
6	BRACKET, BOARD RETURN TABLE	501978-1	1
7	BOLT,M8X25-8.8-B HEX HEAD FULL THREAD	F81002-5	4
8	BOLT, M10-1.5X25MM HH GR8.8	F81003-11	14
9	NUT, M8-8-B, HEX,NYLON LOCK ZINC	F81032-2	4
10	NUT,M10-8-B NYLON HEX ZINC LOCK	F81033-1	4
11	WASHER, 8.4 FLAT,ZINC	F81054-1	8
12	WASHER, 10.5 FLAT ZINC	F81055-1	18
13	STAND, HYDRAULIC CONTROL BOX COMPLETE	502345	1
14	COVER, HYDRAULIC HOSE - SPECIAL	502500-1	1
15	BRACKET, "M" LONG TABLE	502519-1	1

8

Bed Frame Assembly*Board Return Table, Stationary "M" Frame Option*

16	TUBE, TABLE LEG	502520-1	1	
17	BOLT, M8X25-8.8-B HEX HEAD FULL THREAD	F81002-5	5	
18	BOLT, M10-1.5X25MM HH GR8.8	F81003-11	2	
19	BOLT, M10X125-8.8 HEX HEAD ZINC	F81003-18	1	
20	BOLT, M10X30-5.8 HEX HEAD FULL THREAD ZINC	F81003-2	1	
21	NUT, M8-8-B, HEX,NYLON LOCK ZINC	F81032-2	9	
22	WASHER, 8.4 FLAT,ZINC	F81054-1	10	
23	WASHER, 10.5 FLAT ZINC	F81055-1	8	
24	TABLE, M FRAME LONG	502539	1	
25	BOLT, M10-1.5X25MM HH GR8.8	F81003-11	2	
26	NUT, M6, HEXAGON,FREE, GRADE 5(8.8) ZINC	F81031-1	2	
27	WASHER, 10.5 FLAT ZINC	F81055-1	4	

8.11 Board Return Table (LT40M A/DH4-7 Option)

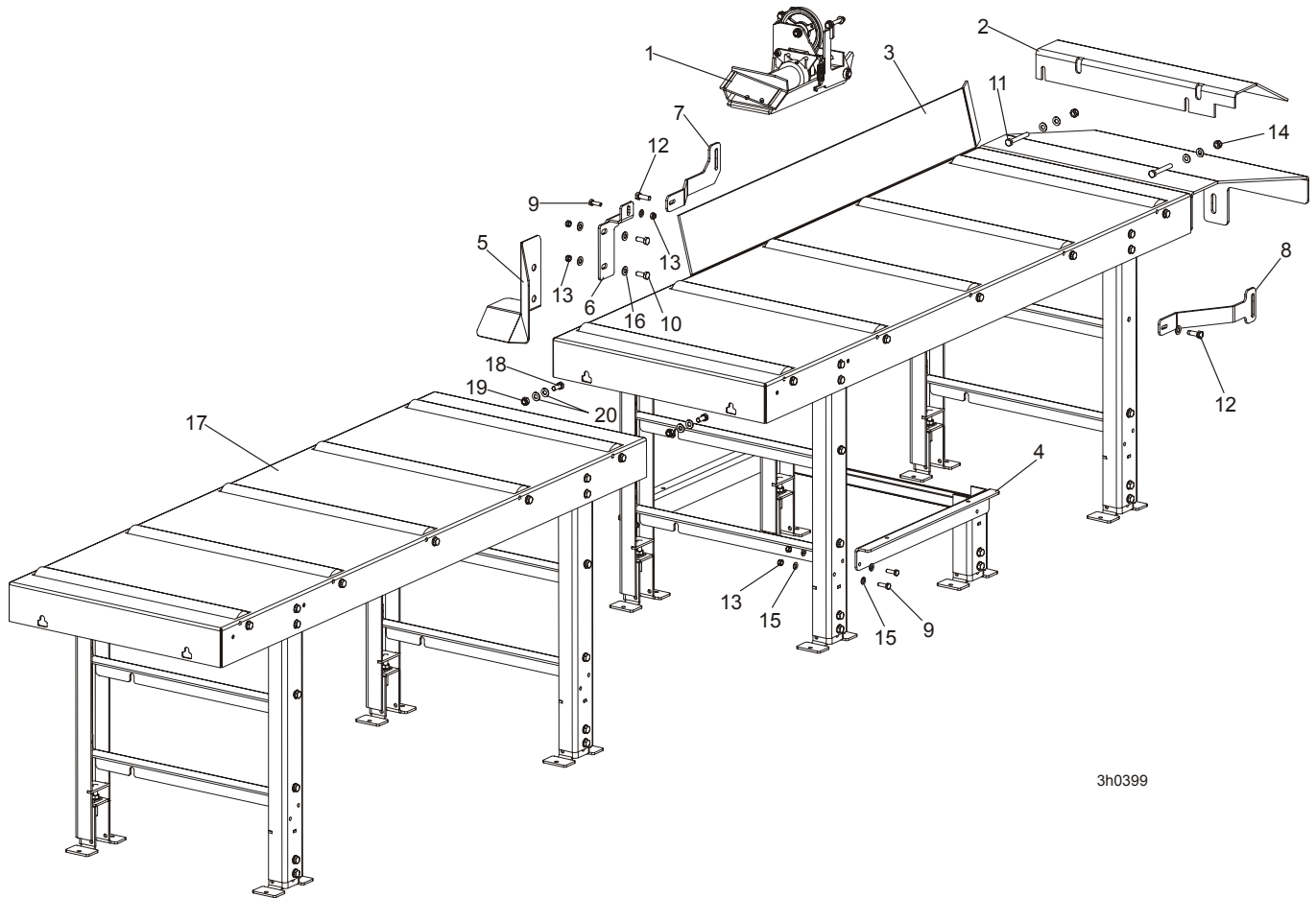

3h0399

REF	DESCRIPTION (◆ Indicates Parts Available In Assemblies Only)	PART #	QTY.
	TABLE, LT40M A/DH4-7 DOUBLE	502801	1
	BOARD RETURN TABLE - LT40M LONG TABLE	502799	1
1	BOARD RETURN ASSEMBLY See Section 4.3	087839-1	1
2	PLATE, BOARD RETURN	099953-1	1
3	TABLE, "M" FRAME LONG SPECIAL	501975	1
4	STAND, HYDRAULIC CONTROL BOX COMPLETE	502345	1
5	COVER, HYDRAULIC HOSE - SPECIAL	502500-1	1
6	BRACKET, "M" LONG TABLE	502519-1	1
7	BRACKET, M A/DH4-7 FRAME TABLE LEFT	502808-1	1
8	BRACKET, M A/DH4-7 FRAME TABLE RIGHT	502809-1	1
9	BOLT, M8X25-8.8-B HEX HEAD FULL THREAD	F81002-5	5
10	BOLT, M10-1.5X25MM HH GR8.8	F81003-11	2
11	BOLT, M10X75-8.8 HEX HEAD ZINC	F81003-15	2
12	BOLT, M10X30-5.8 HEX HEAD FULL THREAD ZINC	F81003-2	2
13	NUT, M8-8-B, HEX,NYLON LOCK ZINC	F81032-2	7
14	NUT, M10-8-B NYLON HEX ZINC LOCK	F81033-1	2
15	WASHER, 8.4 FLAT, ZINC	F81054-1	10
16	WASHER, 10.5 FLAT ZINC	F81055-1	8

8**Bed Frame Assembly***Board Return Table (LT40M A/DH4-7 Option)*

17	TABLE, M FRAME LONG	502539	1	
18	BOLT, M10-1.5X25MM HH GR8.8	F81003-11	2	
19	NUT, M6, HEXAGON,FREE, GRADE 5(8.8) ZINC	F81031-1	2	
20	WASHER, 10.5 FLAT ZINC	F81055-1	4	

8.12 Pivot Bed Rail Assembly

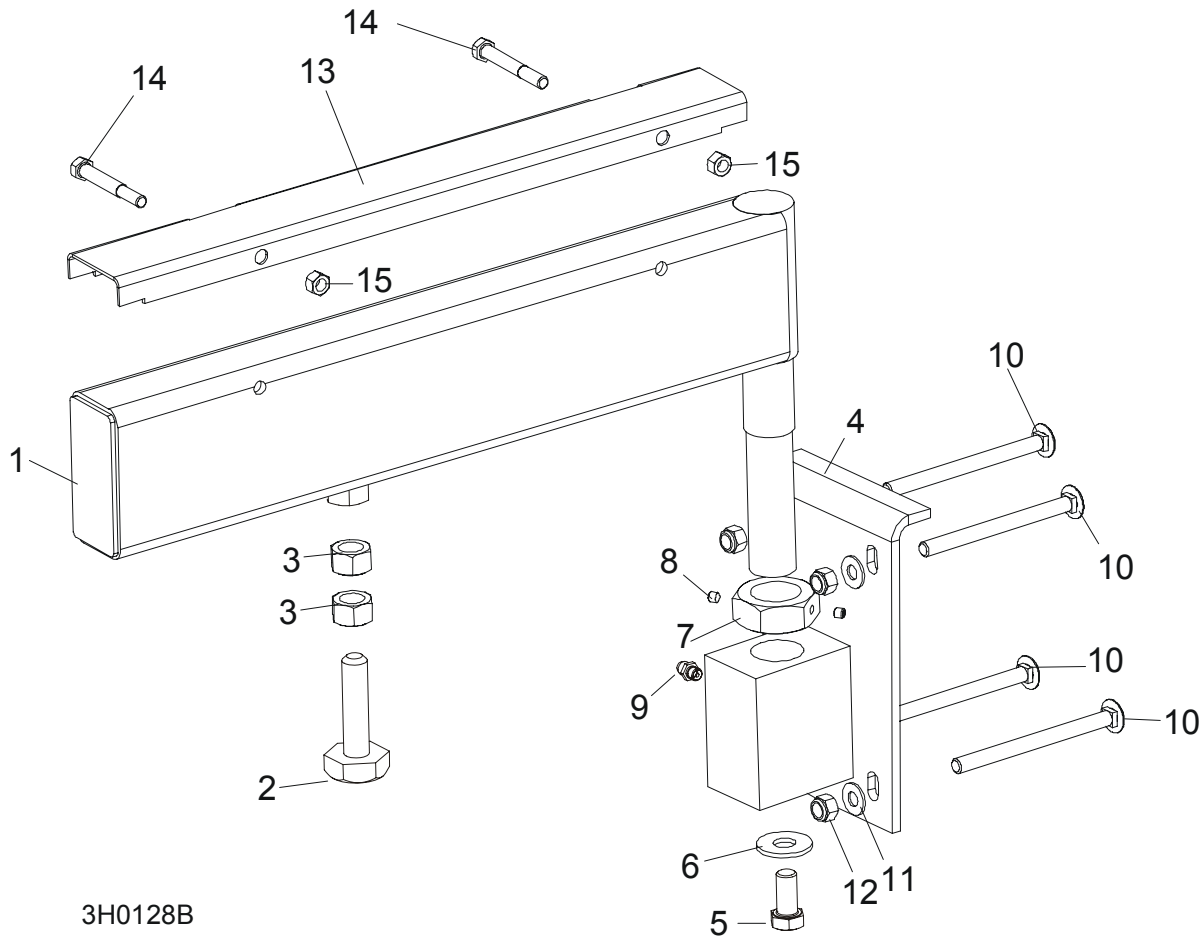

3H0128B

REF	DESCRIPTION (◆ Indicates Parts Available In Assemblies Only)	PART #	QTY.
	PIVOT BED RAIL ASSEMBLY (LT30HD)	087829	2
	PIVOT BED RAIL ASSEMBLY (LT40HD)	087855	2
1	Pivot Bed Rail Weldment (LT30HD)	087852-1	1
	Pivot Bed Rail Weldment (LT40HD)	087848-1	1
	Bolt Assembly, Bed Rail Adjustment		1
2	Bolt, Bed Rail Adjustment	086809	1
3	Nut, 5/8-11 Hex	F81036-1	2
4	Bracket, Pivot Rail Mounting	087841-1	1
5	Bolt, 1/2-13 x 1" Hex Head Grade 2	F81004-31	1
6	Washer, 15 Flat	F05011-52	1
7	Nut, Pivot Rail Adjustment (LT30HD) Nut, Pivot Rail Adjustment (LT40HD)	F81036-1 F81039-2	1
8	Screw, 1/4-28 x 1/4" Brass Tip Set	F05005-42	2
9	Fitting, 3/16" Grease	086280	1
10	BOLT, 3M10 X 120-8.8 CARRIAGE HEAD	F81003-14	2
11	BOLT, 3/8-16 X 5" CARRIAGE HEAD	F05007-113	6
12	WASHER,10.5 FLAT	F81055-1	8
13	NUT, M16-8 NYLON LOCK	F81036-2	8

8 Bed Frame Assembly

Pivot Bed Rail Assembly

	COVER KIT, PIVOT RAIL STAINLESS STEEL (LT30HD)	015926	2	
	COVER KIT, PIVOT RAIL STAINLESS STEEL (LT40HD)	N/A	2	
14	Cover, Stainless Steel Pivot Bed Rail (LT30HD)	012994	1	
	Cover, Stainless Steel Pivot Bed Rail	099123	1	
15	Bolt, 5/16-18 X 2 1/2" Hex Head	F05006-10	2	
16	Nut, 5/16-18 Hex Lock	F05010-6	2	
	WRENCH, BED RAIL ADJUSTMENT (See Section 8.3)	015970	1	

8.13 Bed Rail Assembly, Optional End

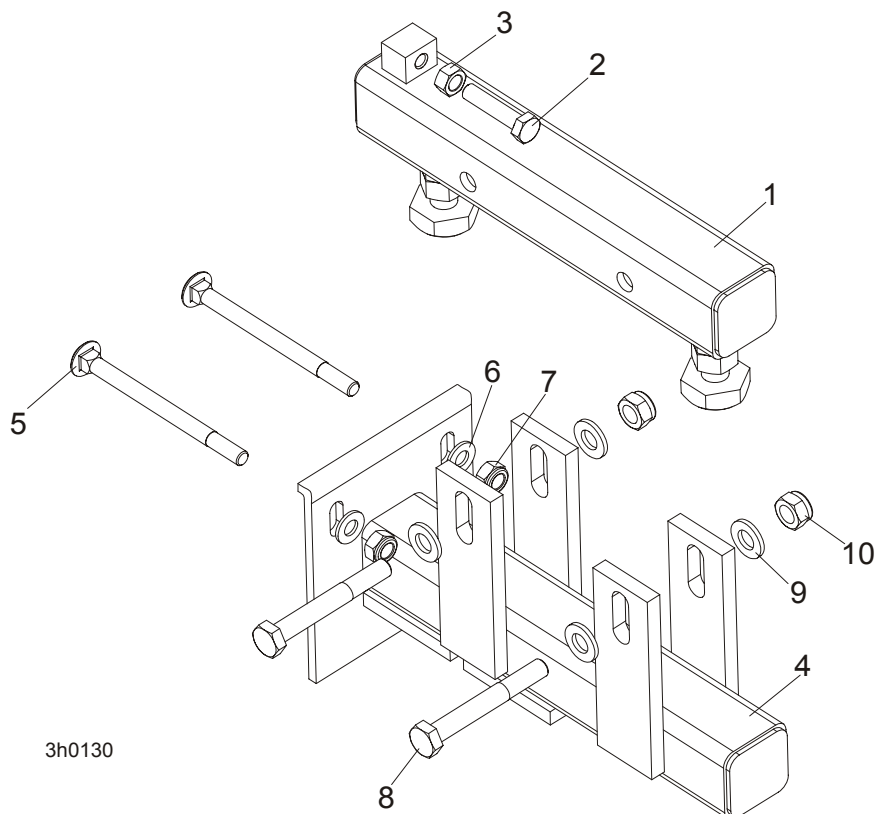

3h0130

REF	DESCRIPTION (◆ Indicates Parts Available In Assemblies Only)	PART #	QTY.
	BED RAIL ASSY, OPTIONAL END	094102	1
1	Zinc-plated Bed Rail	094103-1	1
2	Bolt, M8X45-8.8 Hex Head Full Thread Zinc	F81002-14	1
3	Nut, M8-8-B Hex Zinc	F81032-1	1
4	Bed Rail Weldment, End Painted	094104-1	1
5	Bolt, M10x120 8.8 Mushroom Head Square Neck Zinc	F81003-33	2
6	Washer, 10.5 Zinc Flat	F81055-1	2
7	Nut, M10-8-B Hex Nylon Zinc Lock	F81033-1	2
8	Bolt, M12 x 90-8.8 Hex Head Zinc	F81004-2	2
9	Washer, 13 Zinc Flat	F81056-1	4
10	Nut, M12-8 Hex Nylon Zinc Lock	F81034-2	2

8.14 Log Side Support Assembly (Manual)

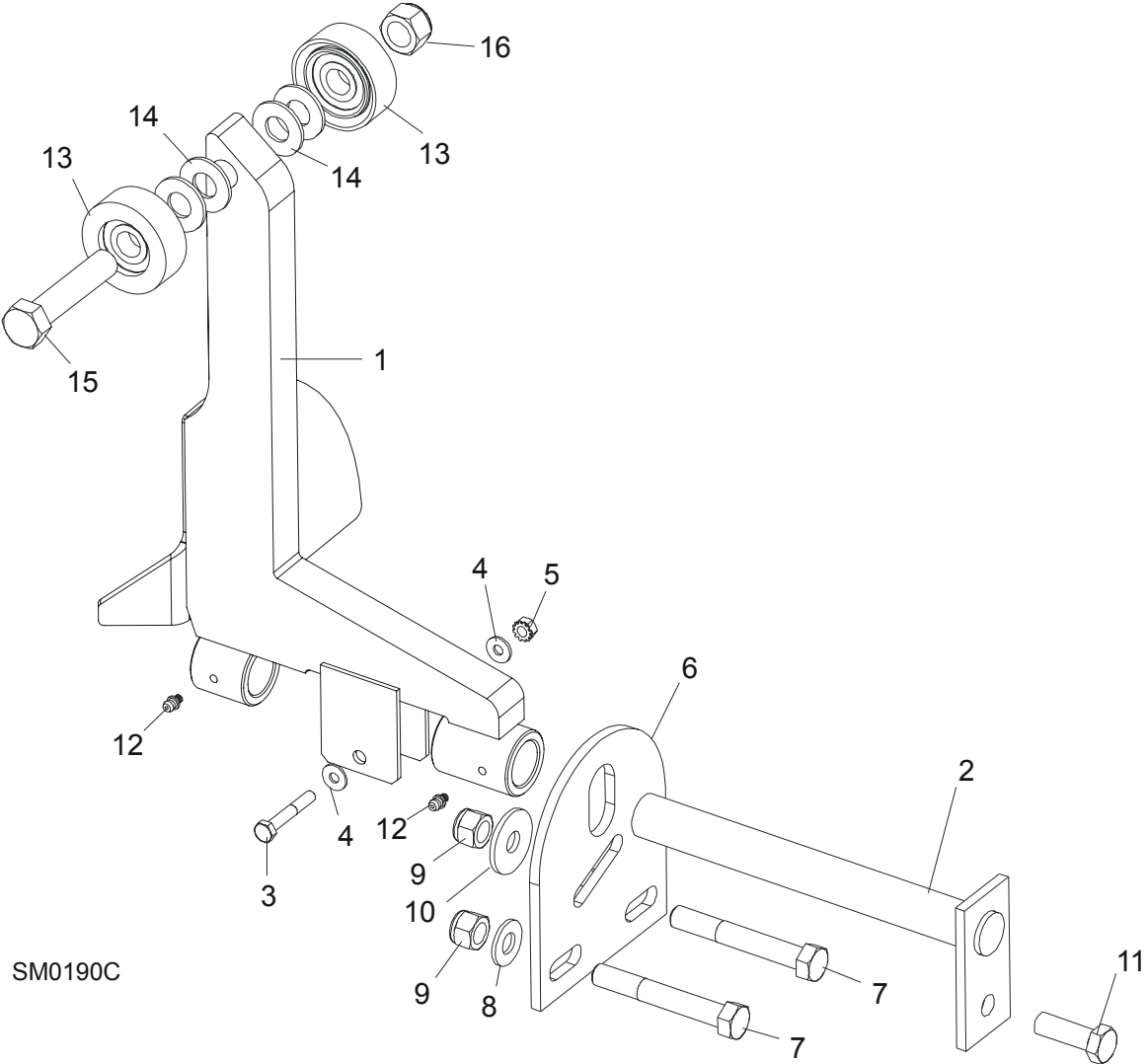

SM0190C

[See Section 9.7](#) for hydraulic side supports...

REF	DESCRIPTION (◆ Indicates Parts Available In Assemblies Only)	PART #	QTY.
1	SUPPORT, LOG SIDE W/GUARD	099785-1	1
2	PIN, LOG SIDE SUPPORT PIVOT	091549-1	1
3	BOLT, M8X45 - 8.8 HEX HEAD GRADE 5	F81002-14	1
4	WASHER, 8.4 FLAT	F81054-1	2
5	NUT, M8-8-B SELF LOCKING	F81032-2	1
6	PLATE, LOG SIDE SUPPORT END	091591-1	1
7	BOLT, M12 X 75-8.8 HEX HEAD	F81004-21	2
8	WASHER, 13 FLAT	F81056-1	2
9	NUT, M12-8 HEX NYLON LOCK	F81034-2	3
10	WASHER, .5" X 1.63" X 11" GA.	086184	1
11	BOLT, M12 X 35-8.8 HEX HEAD	F81004-24	1
12	FITTING, 3/16" GREASE	P04107	2
13	ROLLER ASSEMBLY, SIDE SUPPORT	015014-1	2
14	WASHER, 17 FLAT	F81058-1	2

15	BOLT, M16X65-8.8-B HEX HEAD GRADE 5	F81006-1	1	
16	NUT, M16-8 NYLON LOCK	F81036-2	1	
	INSTRUCTION SHEET, SIDE SUPPORT ROLLER	015109-526	1	

8.15 Tie Down Chain Assembly

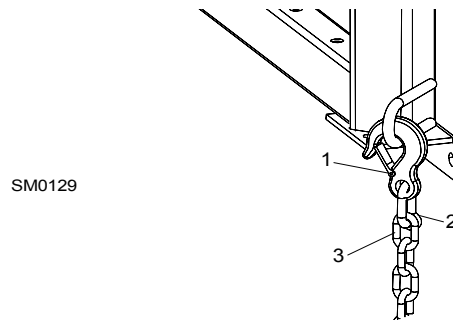

REF	DESCRIPTION (◆ Indicates Parts Available In Assemblies Only)	PART #	QTY.	
	CHAIN ASSEMBLY, TIE DOWN	A04376-1	1	
1	Hook, 5/8" Safety Chain	P12075	1	◆
2	Screw Closed Chain Link, 10	100767	1	◆
3	Chain, N-10 x 35, 6 Links	100951	1	◆

8.16 Saw Head Rest Pin Assembly

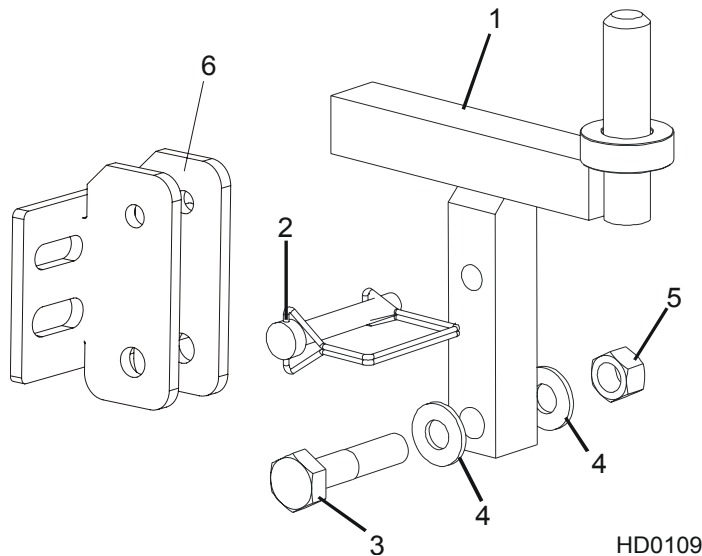

REF	DESCRIPTION (◆ Indicates Parts Available In Assemblies Only)	PART #	QTY.	
1	PIN, SAW HEAD REST	085949	1	
2	PIN, 3/8" X 2 1/4" SNAP RETAINER	014151	1	
3	BOLT, M12 X 60-8.8 HEX HEAD GRADE 5	F81004-5	1	
4	WASHER, 13 SAE FLAT	F81056-1	2	
5	NUT, 1/2-13 HEX LOCK	F05010-3	1	
6	BRACKET, LT40 SAW HEAD REST PIN MOUNT	092765-1	1	

8.17 Saw Head Rest Pin Assembly

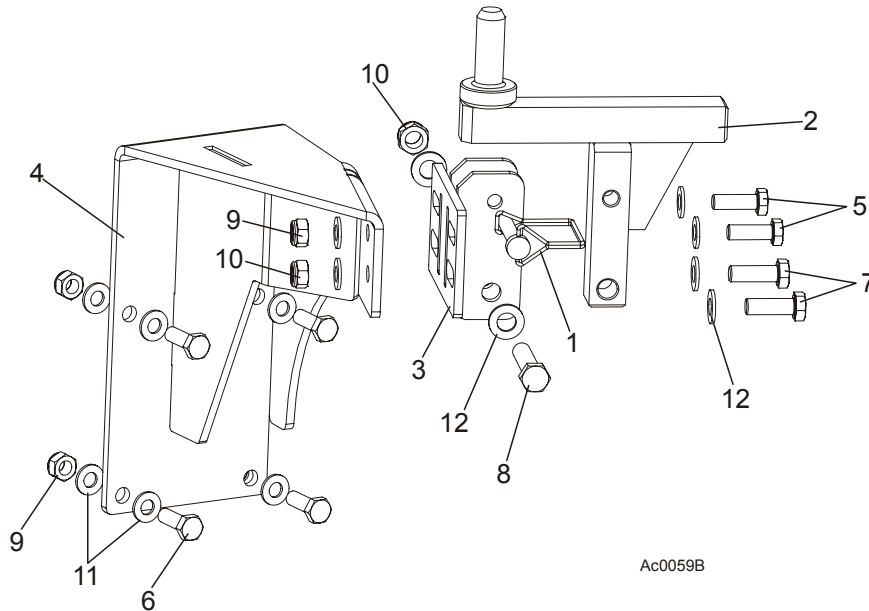

REF	DESCRIPTION (◆ Indicates Parts Available In Assemblies Only)	PART #	QTY.
	KIT, LT40ME15SAH3-1.8 SAW HEAD REST PIN COMPLETE	501627	1
1	PIN, 3/8 X 2 1/4 SQ WIRE LOCK	014151	1
2	PIN, SAW HEAD REST BRACKET	090421-1	1
3	BRACKET, SAW HEAD REST PIN ASSEMBLY	092765-1	1
4	BRACKET, HORIZONTAL	501837-1	1
5	BOLT, M10X35-8.8 HEX HEAD FULL THREAD ZINC	F81003-17	2
6	BOLT, M10x30-5.8 HEX HEAD FULL THREAD ZINC	F81003-2	4
7	BOLT, M12 X 35-8.8-FE/ZN5 HEX HEAD FULL	F81004-24	2
8	BOLT, M12X60MM, HEX HEAD GR 8.8	F81004-5	1
9	NUT, M10-8-B HEX NYLON ZINC LOCK	F81033-1	6
10	NUT, M12-8 HEX NYLON ZINC LOCK	F81034-2	3
11	WASHER, 10.5 FLAT ZINC	F81055-1	12
12	WASHER, 13 FLAT ZINC	F81056-1	6

8.18 Remote Equipment Option

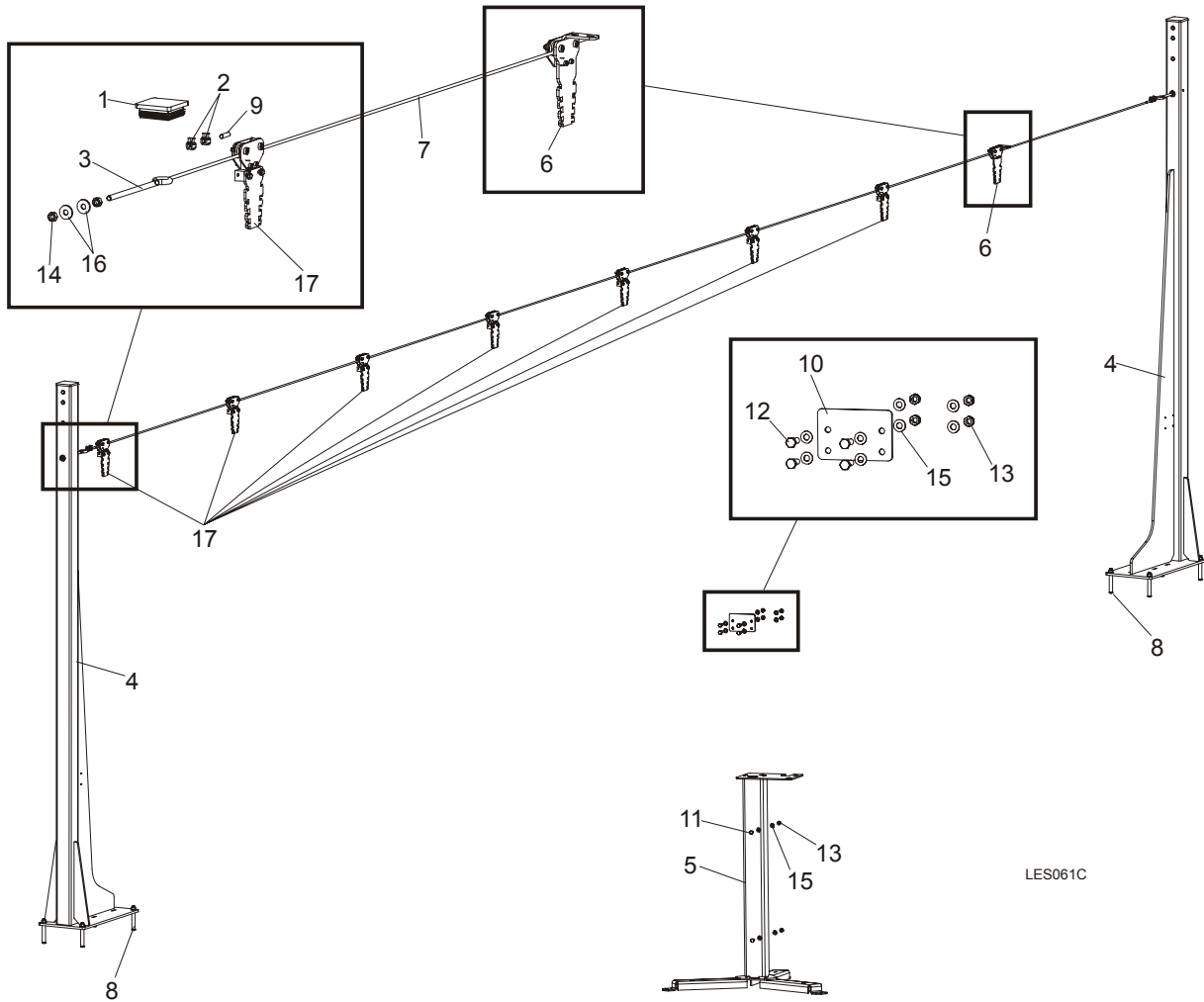

LES061C

REF	DESCRIPTION (◆ Indicates Parts Available In Assemblies Only)	PART #	QTY.
	EQUIPMENT, LT20B REMOTE COMPLETE	501649	1
1	CAP, EDGER FRAME	089644	2
2	CLAMP, LT20 STRING	091614	4
3	TENSIONER, ZINC-PLATED	500846-1	2
4	COLUMN, LT20B LINE GUIDE	503600-1	2
5	STAND, LT20B CONTROL BOX	501651-1	1
6	PULLEY, STATIONARY	504264	1
7	CABLE, 6MM (11,5 M) STEEL	504279	1
8	PIN, LT 16X120	501877	8
9	POINTER, 6MM STEEL CABLE	504280-1	2
10	CAP, LT20B REMOTE CONTROL BOX	501879-1	1
11	BOLT, M8X20-5.8 HEX HEAD FULL THREAD ZINC	F81002-1	2
12	BOLT, M8x25-8.8-B HEX HEAD FULL THREAD ZINC	F81002-5	4
13	NUT, M8-8-B HEX NYLON ZINC LOCK	F81032-2	6
14	NUT, M10-8-B-FE	F81033-3	4
15	WASHER, 8.4 FLAT ZINC	F81054-1	12
16	WASHER, 10.5 ZINC FLAT SPECIAL	F81055-6	4

8 Bed Frame Assembly

Bed Frame Decals

17	PULLEY	504114	7
----	--------	--------	---

8.19 Bed Frame Decals

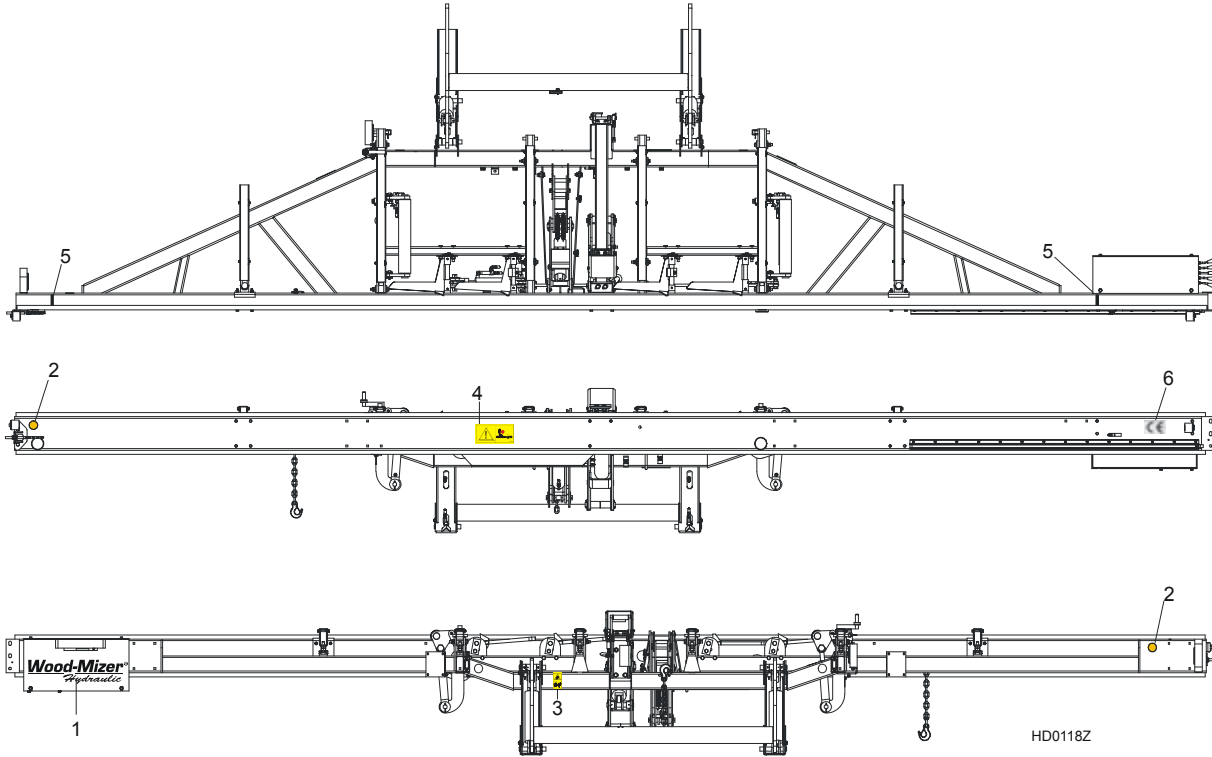

REF	DESCRIPTION (◆ Indicates Parts Available In Assemblies Only)	PART #	QTY.
1	DECAL, WOOD-MIZER SUPER HYDRAULIC LOGO	014168	1
2	DECAL, AMBER REFLECTIVE 2" ROUND	P07453	2
3	DECAL, KEEP AWAY DANGER, PICTOGRAM	099221	1
4	DECAL, SAWMILL TRAILER CAUTION, PICTOGRAM	099542	1
5	DECAL, LOG LIMIT STRIPE	S12051	2
6	DECAL, CE CERTIFIED SAWMILL, SMALL	P85070	1

SECTION 9 HYDRAULIC SYSTEM

9.1 Hydraulic Hoses, LT40 Series AH

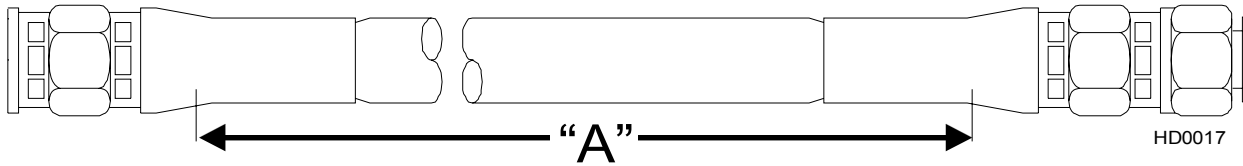

COLOR	LENGTH "A"[m]	DESCRIPTION (◆ Indicates Parts Available In Assemblies Only)	PART #	QTY
None	0,25	3/8" HYDRAULIC PUMP TO VALVE	087774	1
Plain	0,69	3/8" LOG TURNER CYLINDER BASE	014796	1
Orange	0,53	3/8" LOG TURNER CYLINDER TOP	087775	1
Yellow	2,66	1/4" FRONT TOE BOARD TOP (LT40S)	087790	1
	3,81	1/4" FRONT TOE BOARD TOP (LT40M)	087776	1
Gray	2,66	1/4" FRONT TOE BOARD BASE (LT40S)	087790	1
	3,81	1/4" FRONT TOE BOARD BASE (LT40M)	087776	1
Plain	4,21	3/8" SIDE SUPPORT CYLINDER TOP (LT40S)	087791	1
	4,77	3/8" SIDE SUPPORT CYLINDER TOP (LT40M)	087777	1
Pink	4,21	3/8" SIDE SUPPORT CYLINDER BASE (LT40S)	087791	1
	4,77	3/8" SIDE SUPPORT CYLINDER BASE (LT40M)	087777	1
White	3,68	3/8" CLAMP CYLINDER TOP (LT40S)	087792	1
	3,98	3/8" CLAMP CYLINDER TOP (LT40M)	087778	1
Dark Orange	3,27	3/8" CLAMP CYLINDER BASE (LT40S)	087793	1
	3,83	3/8" CLAMP CYLINDER BASE (LT40M)	087779	1
Purple	5,18	1/4" REAR TOE BOARD TOP (LT40S)	087794	1
	5,74	1/4" REAR TOE BOARD TOP (LT40M)	087780	1
Black	5,18	1/4" REAR TOE BOARD BASE (LT40S)	087794	1
	5,74	1/4" REAR TOE BOARD BASE (LT40M)	087780	1
Green	1,58	3/8" LOADING ARM BRANCH TOP	014797	2
Yellow	1,60	3/8" LOADING ARM BRANCH BASE	014798	1
Yellow	1,80	3/8" LOADING ARM BRANCH BASE	093329	1
Blue	4,34	3/8" LOADING ARM CYLINDER TOP (LT40S)	087795	1
	4,90	3/8" LOADING ARM CYLINDER TOP (LT40M)	087781	1
Red	4,34	3/8" LOADING ARM CYLINDER BOTTOM (LT40S)	087795	1
	4,90	3/8" LOADING ARM CYLINDER BOTTOM (LT40M)	087781	1
Green	4,57	1/4" CLAMP UP (LT40S)	087796	1
	5,13	1/4" CLAMP UP (LT40M)	087789	1
Yellow	4,57	1/4" CLAMP DOWN (LT40S)	087796	1
	5,13	1/4" CLAMP DOWN (LT40M)	087789	1
White	4,00	1/4" FRONT LOG CLAMP, IN/OUT CYLINDER BOTTOM (AH5)	094778	1
Orange	4,00	1/4" FRONT LOG CLAMP, IN/OUT CYLINDER TOP (AH5)	094778	1
Red	3,80	1/4" FRONT LOG CLAMP, UP/DOWN CYLINDER BOTTOM (AH5)	094779	1
Blue	3,80	1/4" FRONT LOG CLAMP, UP/DOWN CYLINDER TOP (AH5)	094779	1
White	6,00	1/4" REAR LOG CLAMP, IN/OUT CYLINDER BOTTOM (AH5)	094780	1
Orange	6,00	1/4" REAR LOG CLAMP, IN/OUT CYLINDER TOP (AH5)	094780	1

Red	5,60	1/4" REAR LOG CLAMP, UP/DOWN CYLINDER BOTTOM (AH5)	094781	1	
Blue	5,60	1/4" REAR LOG CLAMP, UP/DOWN CYLINDER TOP (AH5)	094781	1	
Plain	0,40	3/8" HYDRAULIC VALVE TO OIL FLOW CONTROL VALVE (AH5)	094782	1	
Plain	0,53	3/8" HYDRAULIC PUMP TO OIL FLOW CONTROL VALVE (AH5)	087775	1	
Red	1,50	1/4" FIRST CLAMP, UP/DOWN CYLINDER BOTTOM (AH7)	095211	1	
Blue	1,50	1/4" FIRST CLAMP, UP/DOWN CYLINDER TOP (AH7)	095211	1	
Red	4,00	1/4" SECOND CLAMP, UP/DOWN CYLINDER BOTTOM (AH7)	095212	1	
Blue	4,00	1/4" SECOND CLAMP, UP/DOWN CYLINDER TOP (AH7)	095212	1	
Red	8,00	1/4" THIRD CLAMP, UP/DOWN CYLINDER BOTTOM (AH7)	095213	1	
Blue	8,00	1/4" THIRD CLAMP, UP/DOWN CYLINDER TOP (AH7)	095213	1	
Orange	0,40	1/4" HYDRAULIC VALVE POWER CORD TO CLAMP IN/OUT CYLINDER T-FITTING, BOTTOM (AH7)	095214	1	
White	0,40	1/4" HYDRAULIC VALVE POWER CORD TO CLAMP IN/OUT CYLINDER T-FITTING, TOP (AH7)	095214	1	
Orange	7,00	1/4" THIRD CLAMP, IN/OUT CYLINDER BOTTOM (AH7)	095215	1	
White	7,00	1/4" THIRD CLAMP, IN/OUT CYLINDER TOP (AH7)	095215	1	
Orange	2,50	1/4" FIRST/SECOND CLAMP, IN/OUT CYLINDER BOTTOM (AH7)	095216	1	
White	2,50	1/4" FIRST/SECOND CLAMP, IN/OUT CYLINDER TOP (AH7)	095216	1	
Orange	1,20	1/4" FIRST/SECOND CLAMP, IN/OUT CYLINDER BOTTOM (AH7)	095217	1	
White	1,20	1/4" FIRST/SECOND CLAMP, IN/OUT CYLINDER TOP (AH7)	095217	1	

Protective Conduits, LT40 Series AH Hydraulic Hoses

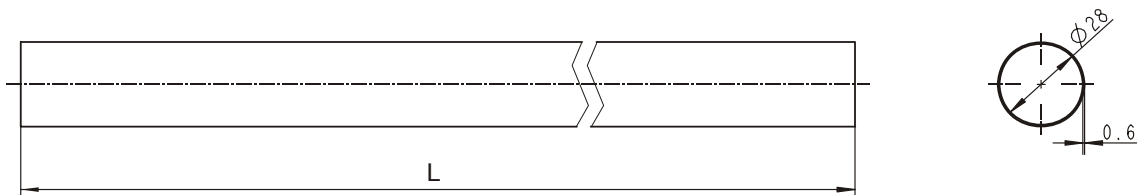

LENGTH "L"	DESCRIPTION (◆ Indicates Parts Available In Assemblies Only)	PART #	QTY.
0,70	PROTECTIVE CONDUIT, LOG TURNER HOSE	099761	2
0,28	PROTECTIVE CONDUIT, IN/OUT CYLINDER HOSE - BOTTOM	099762	1
0,45	PROTECTIVE CONDUIT, IN/OUT CYLINDER HOSE - TOP	099763	1
1,35	PROTECTIVE CONDUIT, UP/DOWN CYLINDER HOSE - BOTTOM	099764	1
1,65	PROTECTIVE CONDUIT, UP/DOWN CYLINDER HOSE - TOP	099765	1

9.2 Hydraulic Control Box, LT40 Series AH3

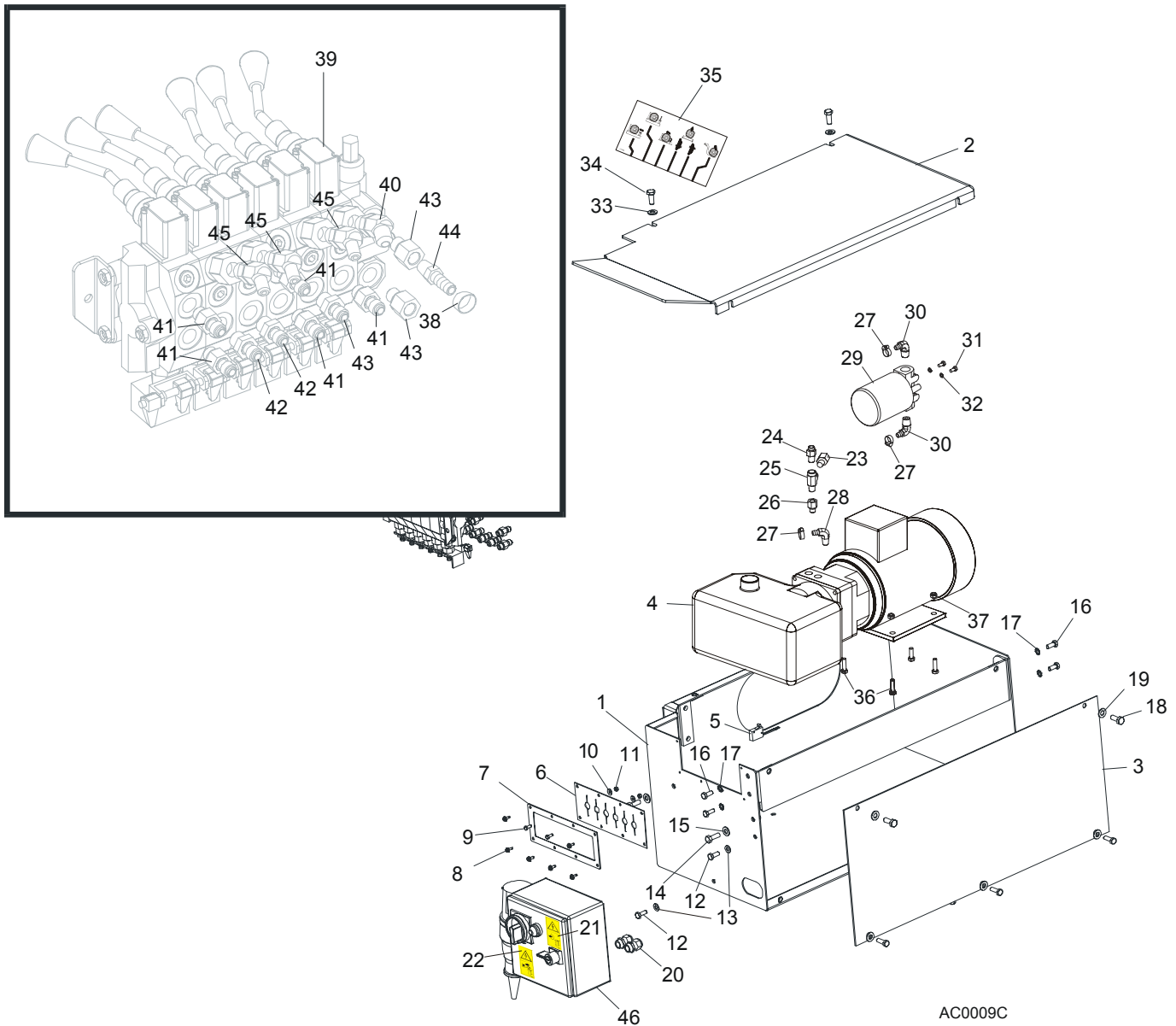

REF	DESCRIPTION (◆ Indicates Parts Available In Assemblies Only)	PART #	QTY.
	BOX, AC SUPER HYDRAULIC (EA20, EA25)	086791	1
	Cap, SR1086 22.2 Hole	093544	2
1	BOX WELDMENT, HYDRAULIC PUMP HOUSING	092243-1	1
2	COVER, AC HYDRAULIC PUMP HOUSING TOP	086485-1	1
3	COVER, AC HYDRAULIC PUMP HOUSING SIDE	086484-1	1
4	HYDRAULIC PUMP W/MOTOR, 4 KW 14.5 L/MIN AC	500958	1
	Pump, AC-4kW Hydraulic	097782	1
	Plate, AC-4kW Hydraulic Connecting	097783	1
	Seal, AC-4kW Hydraulic Complete	097784	1
5	Microswitch, 2A 125V Hydraulic Valve	014765	1
6	GUARD, DOUBLE VALVE RUBBER	015079	1
7	PLATE, AC VALVE PAINTED	086519-1	1

8	SCREW, #10 X 1/2 SLOTTED HEX SELF-TAPPING	F05015-7	6	
9	BOLT, M5X12-5.8 HEX HEAD FULL THREAD ZINC	F81000-5	2	
10	WASHER, 5.5 SPECIAL FLAT ZINC	F81052-3	2	
11	NUT, M5-8 HEX ZINC	F81030-1	2	
12	BOLT, M8 X 20-8.8-B HEX HEAD FULL THREAD ZINC	F81002-4	2	
13	WASHER, 8.4 FLAT ZINC	F81054-1	2	
14	BOLT, 3/8-16X1 HEX HEAD ZINC GRADE 8	F05007-7	2	
15	WASHER, 10.5 FLAT ZINC	F81055-1	2	
16	BOLT, M8 X 20-8.8-B HEX HEAD FULL THREAD ZINC	F81002-4	4	
17	WASHER, 8.4 EXTERNAL STAR LOCK	F81054-3	4	
18	BOLT, M10 X 25-8.8 HEX HEAD FULL THREAD ZINC	F81003-11	4	
19	WASHER, 10.5 FLAT ZINC	F81055-1	4	
20	GLAND, DP 11/H CABLE (SUPER ONLY)	085388	2	
21	DECAL, HIGH VOLTAGE INSIDE THE ELECTRIC BOX (PICTOGRAM)	096316	1	
22	DECAL, REMOVE THE PLUG BEFORE OPENING THE BOX (PICTOGRAM)	096319	1	
23	PLUG, 1/4" NPT BLANK	096221	1	
24	FITTING, 1/4NPT X 1/4JIC MALE	P09143	1	
25	FITTING, 1/4NPT X 1/4JIC MALE RUN TEE	P09141	1	
26	FITTING, 6SAE MALE - 1/4NPT FEMALE	014686	1	
27	CLAMP, 11/16 HOSE	P12739	3	
28	FITTING, 3/8" NPT - 3/8" BARB ELBOW	P12708	1	
29	MANIFOLD, 1.2" W/FILTER	P22683	1	
30	FITTING, 1/2" NPT - 3/8" BARB ELBOW	P12707	2	
31	BOLT, 1/4-20 X 1/2" HEX HEAD ZINC GRADE 2	F05005-15	2	
32	WASHER, 6.1 SPLIT LOCK ZINC	F81053-3	2	
33	WASHER, 10.5 FLAT ZINC	F81055-1	2	
34	BOLT, M10 X 25-8.8 HEX HEAD FULL THREAD ZINC	F81003-11	2	
35	DECAL, 1997 SUPER HYDRAULIC CONTROL BOX	015364	1	
36	BOLT, M8 X 30-8.8-B HEX HEAD FULL THREAD ZINC	F81002-7	4	
37	NUT, M8-8-B HEX NYLON ZINC LOCK	F81032-2	4	
38	CLAMP, 11/16" HOSE	P12739	10	
39	VALVE, HYDRAULIC 6-SECTION	086589	1	
	MICROSWITCH ASSEMBLY, HYDRAULIC VALVE	024198	1	
40	FITTING, #6 SAE 45° ELBOW	015489	1	
41	FITTING, 3/8" O-RING - 3/8" JIC	014687	5	
42	FITTING, 3/8" O-RING - 1/4" JIC	P26284	3	
43	FITTING, #6 SAE MALE - 1/4" NPT FEMALE	014686	2	
44	FITTING, 1/4" NPT X 3/8" HOSE BARB	014685	1	
45	FITTING, #6 SAE - 1/4" JIC 45° ELBOW	015488	3	
46	BOX, 4KW AC ELECTRIC <i>(See Section 1.19 Electrical Information, 920 Operation Manual)</i>	089799	1	
	Switch, ABB OT16F3	503541	1	
	Contactors, LC1K0910B7	084451	1	
	Switch, C60N 24395	084454	1	
	Circuit Breaker, C60N 1P 2A 24396	088278	1	
	Phase Supply Control Relay, 72.31.8.400.0000	501016	1	
	Time Relay, RELPOL MT-TUA-17S-11-92	501015	1	
	Thermal Overload Relay, LR2 K0316	084456	1	

9.3 Hydraulic Control Box, LT40 Series AH5/7

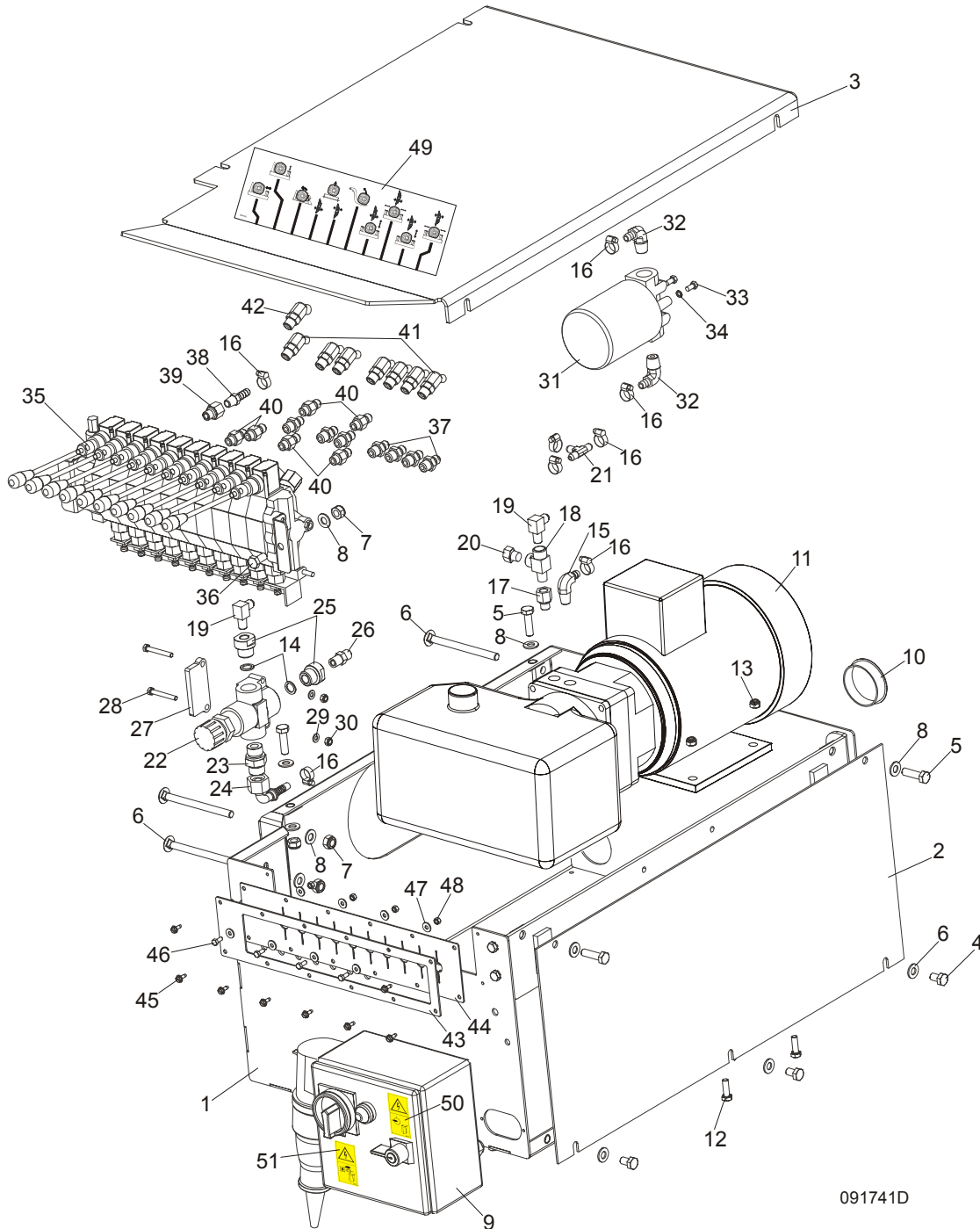

091741D

REF	DESCRIPTION (◆ Indicates Parts Available In Assemblies Only)	PART #	QTY.
	BOX ASSEMBLY, LT40 AH5 HYDRAULIC CONTROL	091741	1
1	Box Weldment, Hydraulic Pump Housing	091729-1	1
	Bracket, AC Hydraulic Control Box	086518-1	1
	Bolt, M8X20mm, Hex Head,GR 5.8 Zinc	F81002-4	4
	Washer, M8 Crown Lock Zinc	F81054-3	4
2	Cover, AC Hydraulic Pump Housing Side	086484-1	1
3	Cover, AC/DC Hydraulic Pump Housing Top	091734-1	1

4	Bolt, M10x16-8.8 Hex Head Full Thread Zinc	F81003-13	3	
5	Bolt, M10x35-8.8 Hex Head Full Thread Zinc	F81003-17	4	
6	Bolt, M10x125 8.8 Carriage Head Zinc	F81003-34	4	
7	Nut, M10-8-B Hex Nylon Zinc Lock	F81033-1	6	
8	Washer, 10.5 Flat Zinc	F81055-1	13	
9	Box, 4kW AC Electric (See Section 1.19 Electrical Information, 920 Operation Manual)	089799	1	
	Switch, ABB OT16F3	503541	1	
	Contactora, LC1K0910B7	084451	1	
	Switch, C60N 24395	084454	1	
	Circuit Breaker, C60N 1P 2A 24396	088278	1	
	Phase Supply Control Relay, 72.31.8.400.0000	501016	1	
	Time Relay, RELPOL MT-TUA-17S-11-92	501015	1	
	Thermal Overload Relay, LR2 K0316	084456	1	
10	Cap, HSA2790 (63.6 Dia.)	092859	1	
11	Hydraulic Pump W/Motor, 4 kW 14.5 l/min AC	500958	1	
	Pump, AC-4kW Hydraulic	097782	1	
	Plate, AC-4kW Hydraulic Connecting	097783	1	
	Seal, AC-4kW Hydraulic Complete	097784	1	
12	Bolt, M8 x 30-8.8-B Hex Head Full Thread Zinc	F81002-7	4	
13	Nut, M8-8-B Hex Nylon Zinc Lock	F81032-2	4	
14	Washer, 22x26 Copper	F81061-5	2	
15	Fitting, 3/8" NPT - 3/8" Barb Elbow	P12708	1	
16	Clamp, 11/16 Hose	P12739	8	
17	Fitting, 6 SAE Male - 1/4 NPT Female	014686	1	
18	Fitting, 1/4 NPT x 1/4 JIC Male Run Tee	P09141	1	
19	Fitting, 3/8 JIC - 1/4 NPT 90L	015491	2	
20	Plug, 1/4" NPT Blank	096221	1	
21	Fitting, 3/8" Barb Tee	015485	1	
22	Valve, MTKA.VB Oil Flow Control	093794	1	
23	Fitting, VMNW10HS22	094486	1	
24	Fitting, PN10AOL13-90 Elbow	094485	1	
25	Fitting, M22x1.5 / 1/4 - 18 NPT Zinc	093139-1	2	
26	Fitting, 3/8JIC-1/4 NPT Straight	015560	1	
27	Plate, MTKA Control Valve Spacer Zinc-Plated	094477-1	1	
28	Bolt, M6x45-8.8 Hex Head Zinc	F81001-6	2	
29	Washer, 6.4 Flat Zinc	F81053-1	2	
30	Nut, M6-8-B Hex Nylon Zinc Lock	F81031-2	2	
31	Manifold, 1.2" W/Filter	P22683	1	
32	Fitting, 1/2" NPT - 3/8" Barb Elbow	P12707	2	
33	Bolt, 1/4-20 x 1/2" Hex Head Zinc Grade 2	F05005-15	2	
34	Washer, Z6.1 Split Lock Zinc	F81053-3	2	
35	Valve, HDS11/10 6-Section Hydraulic	091344	1	
36	Bolt, M10x20-5.8 Hex Head Full Thread Zinc	F81003-1	2	
37	Fitting, 3/8" O-Ring - 1/4" JIC	P26284	7	
38	Fitting, 1/4" NPT x 3/8" Hose Barb	014685	1	
39	Fitting, #6 SAE Male - 1/4" NPT Female	014686	1	
40	Fitting, 3/8" O-Ring - 3/8" JIC	014687	6	
41	Fitting, #4 SAE - #6 SAE 45° Elbow	015488	7	

42	Fitting, #6 SAE 45° Elbow	015489	1	
43	Plate, 10-Section Valve Painted	091826-1	1	
44	Guard, 10-Section Valve Rubber	091739	1	
45	Screw, #10-24x1/2 Self-Tapping	F05015-7	8	
46	Bolt, M5x12-5.8 Hex Head Full Thread Zinc	F81000-5	4	
47	Washer, 5.5 Special Flat Zinc-Plated	F81052-3	8	
48	Nut, M5-8 Hex Zinc	F81030-1	4	
49	Decal, AH5 Hydraulic Control Box	094795	1	
	Decal, AH7 Hydraulic Control Box	094970	1	
50	DECAL, HIGH VOLTAGE INSIDE THE ELECTRIC BOX (PICTOGRAM)	096316	1	
51	DECAL, REMOVE THE PLUG BEFORE OPENING THE BOX (PICTOGRAM)	096319	1	

9.4 Hydraulic Power Supply Strip

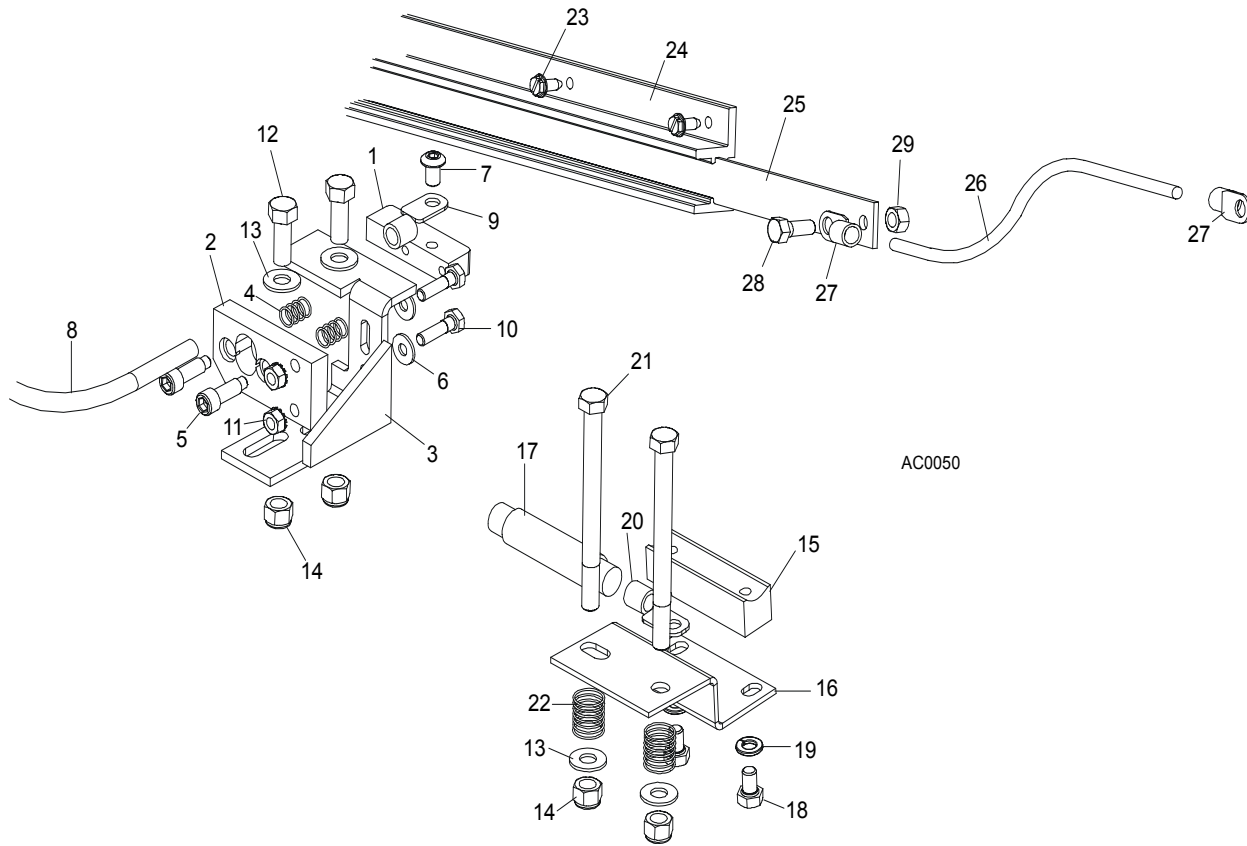

REF	DESCRIPTION (◆ Indicates Parts Available In Assemblies Only)	PART #	QTY.	
	CONTACT ASSEMBLY, HYDRAULIC POWER SUPPLY (POSITIVE)	086625	1	
1	Contact, Hydraulic Power Supply (Positive)	015253	1	
2	Insulator, Positive Contact	095934	1	
3	Bracket, Positive Contact Mounting	086380-1	1	
4	Spring, Positive Contact	P10077	2	
5	Bolt, 5/16" X 3/4" Shoulder (1/4-20 Thread)	F05006-44	2	
6	Washer, 8.4 Flat Zinc	F81054-1	2	
7	Screw, M8x12Socket Button Head Zinc	F81014-4	1	
8	Cable, LGY 1mm2 Red	R80583-2	1 m	◆
9	Terminal, KO 1/10	F81064-11	2	
10	Bolt, 1/4-20 X 1" Hex Head Zinc Grade 2	F05005-38	2	
11	Nut, 1/4-20 Self-Locking Zinc	F05010-9	2	
12	Bolt, 3/8-16 X 1 Hex Head Zinc Grade 5	F05007-87	2	
13	Washer, 10.5 Flat Zinc	F81055-1	4	
14	Nut, 3/8-16 Hex Nylon Lock	F05010-10	4	
	CONTACT ASSEMBLY, HYDRAULIC POWER SUPPLY (GROUND)	086624	1	
15	Contact, Hydraulic Power Supply (Ground)	015264	1	
16	Bracket, Ground Contact Mounting	090254-1	1	
17	Cable, LGY 1mm2 Black	R80583-21	.21m	◆
18	Bolt, 5/16-18x1/2 HH Gr5	F05006-15	2	
19	Washer, 8.2 Split Lock Zinc	F81054-4	2	
20	Terminal, KO 1/10	F81064-11	1	

21	Bolt, 3/8-16 x 4 1/2 Hex Head Zinc Grade 2	F05007-35	2	
22	Spring, Ground Contact	P04282	2	
23	Screw, 1/4-20 x 1/2" Type "23" Self-Tapping	F05015-1	14	
	STRIP ASSEMBLY, HYDRAULIC POWER SUPPLY	086653	1	
	Strip, Contact, complete	096234	1	
24	Housing, Contact Strip	P11976	1	◆
25	Strip, Contact	095932	1	◆
26	Cable, #2 Weld	R80583-21	19m	◆
27	Terminal, KO 1/10	F81064-11	4	
28	Bolt, 5/16-18 X 3/4" Hex Head Black Nylon	F05006-45	1	
29	Nut, 5/16-18 Hex Self-Locking	F05010-86	1	

9.5 Hydraulic Log Loader

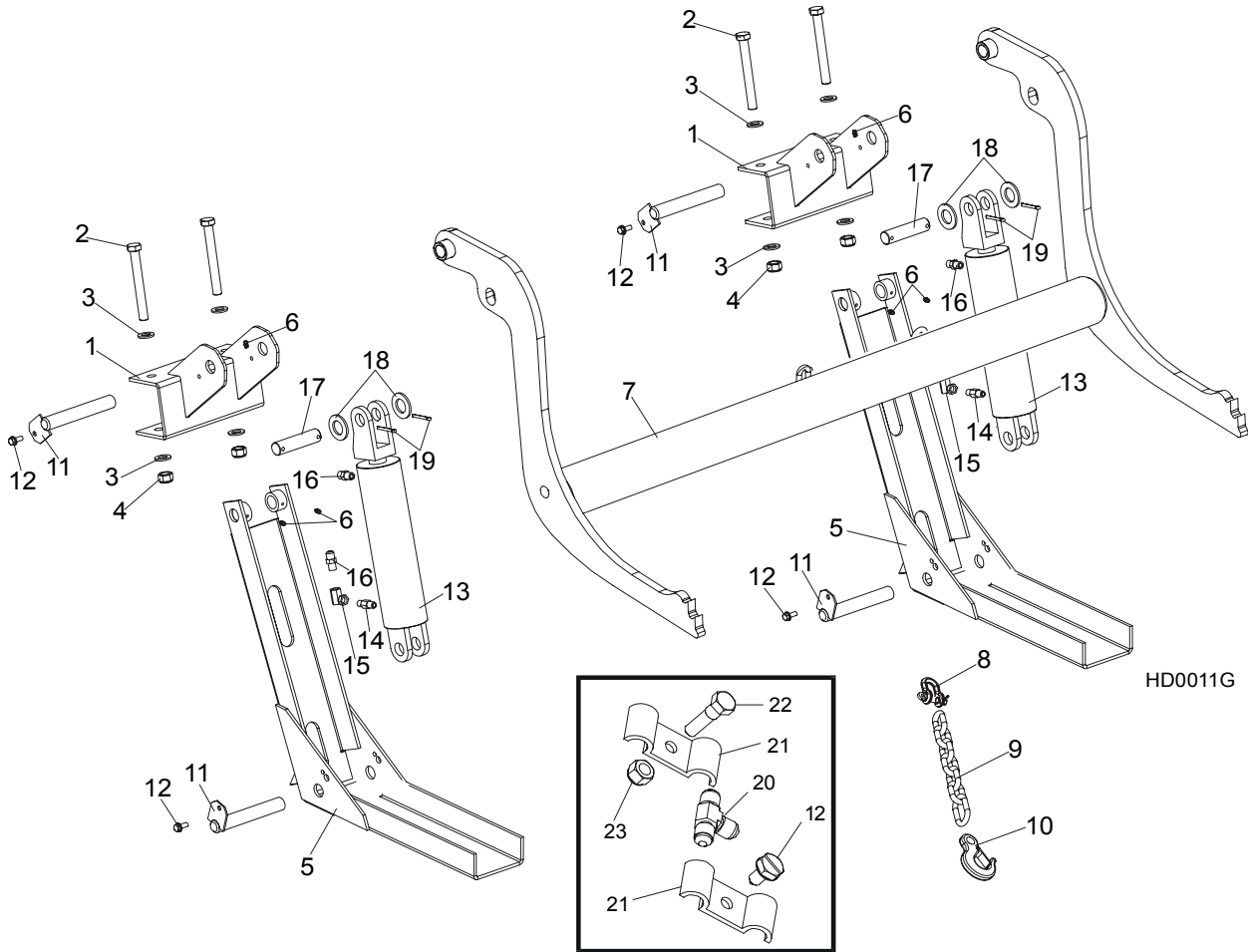

REF	DESCRIPTION (◆ Indicates Parts Available In Assemblies Only)	PART #	QTY.
	HYDRAULIC LOG LOADER - COMPLETE	092863	1
1	Bracket, Log Loader Mount	092865-1	1
2	Bolt, M16x140-8.8 Hex Head Zinc	F81006-4	4
3	Washer, 17 Flat Zinc	F81058-1	8
4	Nut, M16-8 Hex Nylon Zinc Lock	F81036-2	4
	Channel, Hydraulic Log Loading Foot Complete	090049	2
5	Channel, Hydraulic Log Loading Foot	090048-1	2
6	Fitting, 3/16x3/16 Straight Grease	P04107	6
	Arm, Hydraulic Log Loading Complete	090044	1
7	Arm, Hydraulic Log Loading	090006-1	1
8	Shackle, M-D .63	086540	1
9	Chain, Hydraulic Log Loader Safety	090007-1	1
10	Hook, 5/8 Safety Chain	P12075	1
11	Pin, Turner Arm	099127-1	4
12	Screw, 5/16-18x3/4 Self-Tapping	F05015-30	4
13	Cylinder Assy, Log Loading Super	015562	2
14	Fitting, 1/4NPT Velocity Fuse 5.0GPM	015750	2
15	Fitting, 1/4NPT-1/4JIC Swivel Elbow	P12199	2
16	Fitting, 3/8JIC-1/4NPT Straight	015560	4

17	Washer, 28 Flat Zinc	F81061-1	4	
18	Fitting, 1/4JIC Union Tee	P09145	2	
19	Fitting, 3/8 Barb Tee	015485	1	
20	Plate, 1/4 Hose Clamp Painted	S09245	6	
21	Clamp, 3/8 Hose	016041	2	
22	Bolt, 5/16-18x1 Hex Head Zinc Grade 2	F05006-1	1	
23	Nut, 5/16-18 Self-Locking Nylon Zinc	F05010-58	1	

9.6 Hydraulic Log Turner

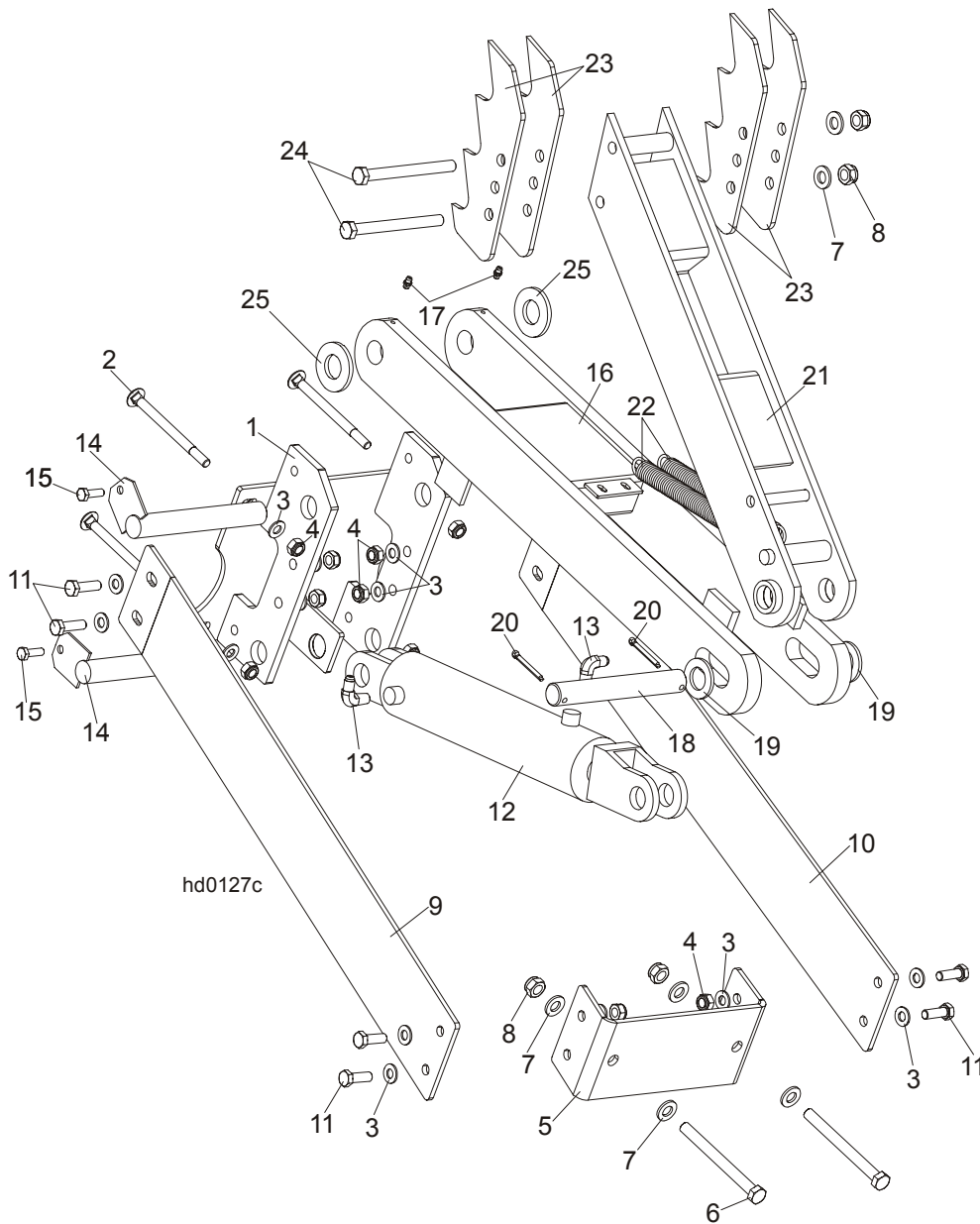

REF	DESCRIPTION (◆ Indicates Parts Available In Assemblies Only)	PART #	QTY.
	HYDRAULIC LOG TURNER OPTION (S/M TYPE FRAME)	088711	1
1	Bracket, Hydraulic Log Turner (S/M TYPE FRAME)	088710-1	1
2	Bolt, M10x120 8.8 Carriage Head Zinc	F81003-33	4
3	Washer, 10.5 Flat Zinc	F81055-1	20
4	Nut, M10-8-B Hex Nylon Zinc Lock	F81033-1	12
5	Bracket, Hydraulic Log Turner Front	091046-1	1
6	Bolt, M12x130-8.8 Hex Head Zinc	F81004-36	2
7	Washer, 13 Flat Zinc	F81056-1	6
8	Nut, M12-8 Hex Nylon Zinc Lock	F81034-2	4
9	Plate, Hydraulic Log Turner Left	091048-1	1
10	Plate, Hydraulic Log Turner Right	091049-1	1

11	Bolt, M10x30-5.8 Hex Head Full Thread Zinc	F81003-2	8	
	Cylinder Assy, Log Turner Super	015563	1	
12	Cylinder, CJ-S305-16-63/28/203 Hydraulic	088679	1	
13	Fitting, 1/4NPTx1/4JIC Male Elbow	P09142	2	
14	Pin, Log Turner Mount	088667-1	2	
15	Bolt, M8x25-8.8-B Hex Head Full Thread Zinc	F81002-5	2	
16	Arm, Hydraulic Log Turner Link	088060-1	1	
17	Fitting, M6 Grease	086280	2	
18	Pin, 25 X 180	088664	1	
19	Washer, 25 Flat Zinc	F81061-3	2	
20	Pin, 5x40 Cotter	F81043-31	2	
21	Arm, Hydraulic Log Turner Painted	088067-1	1	
22	Spring, 7/8x8 1/2x1/8 Extension	P09136	2	
23	Claw, Hydraulic Log Turner	088082-1	4	
24	Bolt, M12x130-8.8 Hex Head Zinc	F81004-36	2	
25	Washer, GTM-2644-015	093359	2	

9.7 Hydraulic Log Side Supports

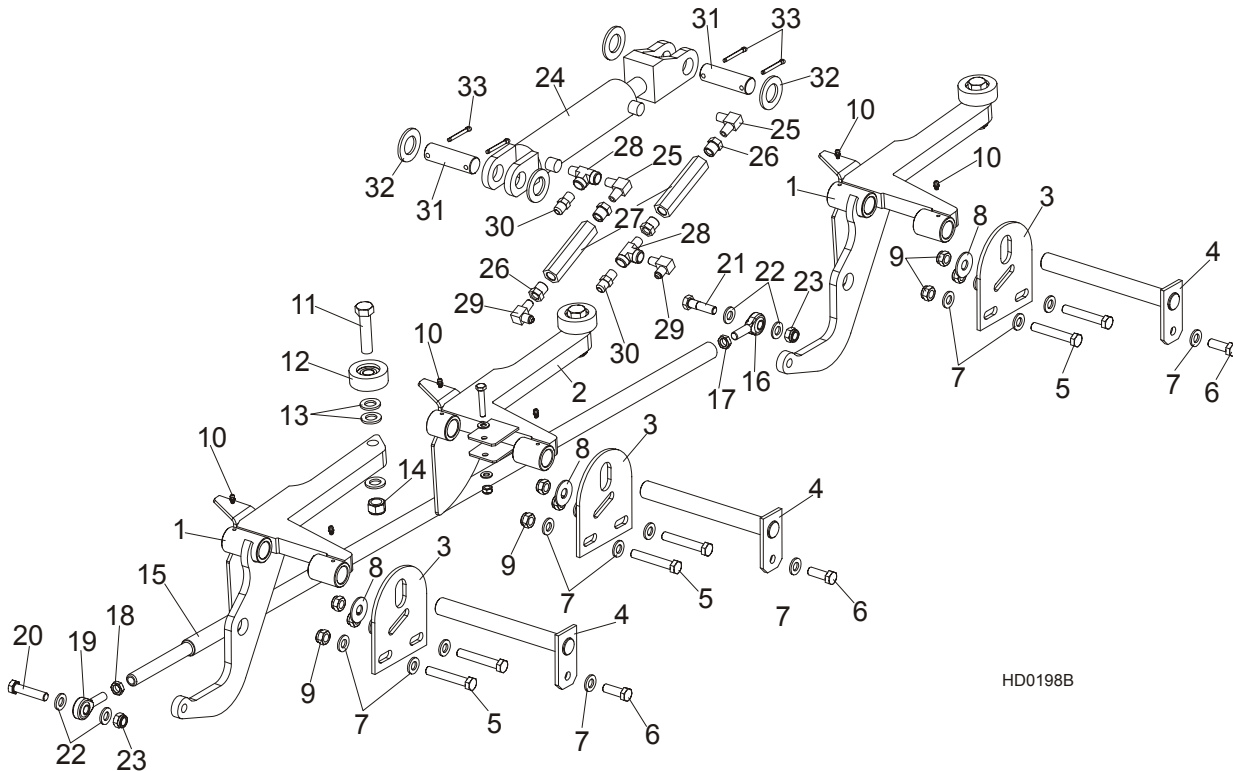

REF	DESCRIPTION (◆ Indicates Parts Available In Assemblies Only)	PART #	QTY.
	LOG SIDE SUPPORT KIT, S/M FRAME	092611	1
1	SUPPORT, HYDRAULIC LOG SIDE W/GUARD	099788-1	2
2	SUPPORT, LOG SIDE W/GUARD	099785-1	1
3	PLATE, LOG SIDE SUPPORT END	091591-1	3
4	PIN, LOG SIDE SUPPORT PIVOT	091549-1	3
5	BOLT, M12 X 75-8.8 HEX HEAD FULL THREAD ZINC	F81004-21	6
6	BOLT, M12 X 35-8.8 HEX HEAD FULL THREAD ZINC	F81004-24	3
7	WASHER, 13 FLAT ZINC	F81056-1	15
8	WASHER, 15 FLAT SPECIAL ZINC-PLATED	F81057-3	3
9	NUT, M12-8 HEX NYLON ZINC LOCK	F81034-2	9
10	FITTING, 3/16" STRAIGHT GREASE	P04107	6
11	BOLT, M16X65-8.8 HEX HEAD FULL TREAT	F81006-1	3
12	ROLLER ASSY, SIDE SUPPORT, PTD	015014-1	3
13	WASHER, 17 FLAT ZINC	F81058-1	9
14	NUT, M16,HEX, NYLON ZINC LOCK	F81036-2	3
15	ROD, SIDE SUPPORT LINK COMPLETE	091640	1
15	ROD, SIDE SUPPORT LINK ZINC-PLATED	089374-1	1
16	ROD END (LEFT THREAD)	087036	1
17	NUT, M12-04-A RIGHT HEX THIN	F81034-6	1
18	NUT, M12-04-A LEFT HEX THIN	F81034-7	1
19	ROD END (RIGHT THREAD)	087035	1
20	BOLT, M12 X 55-8.8 HEX HEAD FULL THREAD ZINC	F81004-12	1
21	BOLT, M12 X 45-8.8 HEX HEAD FULL THREAD ZINC	F81004-32	2

22	WASHER, 13 FLAT ZINC	F81056-1	4	
23	NUT, M12-8 HEX NYLON ZINC LOCK	F81034-2	2	
	CYLINDER ASSEMBLY, SUPER HYDRAULIC LOG SIDE SUPPORT	015561	1	
24	CYLINDER, CJ-S270-16-50/28/152 HYDRAULIC	088678	1	
	SEAL KIT, 6" X 2" HYDRAULIC CYLINDER	P12954	1	
25	FITTING, #C3529X4 90° ELBOW	P09140	2	
26	FITTING, 3/8" NPT - 1/4" NPT REDUCER	015490	4	
27	VALVE, SIDE SUPPORT SEQUENCE	015484	2	
28	FITTING, C3759X4 MALE TEE	P09141	2	
29	FITTING, C3759X4 MALE TEE	P09141	2	
30	FITTING, 3/8" JIC - 1/4" NPT STRAIGHT	015560	2	
31	PIN, HYDRAULIC CYLINDER ZINC-PLATED	086979-1	2	
32	WASHER, 28 FLAT ZINC	F81061-1	4	
33	PIN, 5 X 40 COTTER	F81043-31	4	

9.8 Hydraulic Log Clamp - main

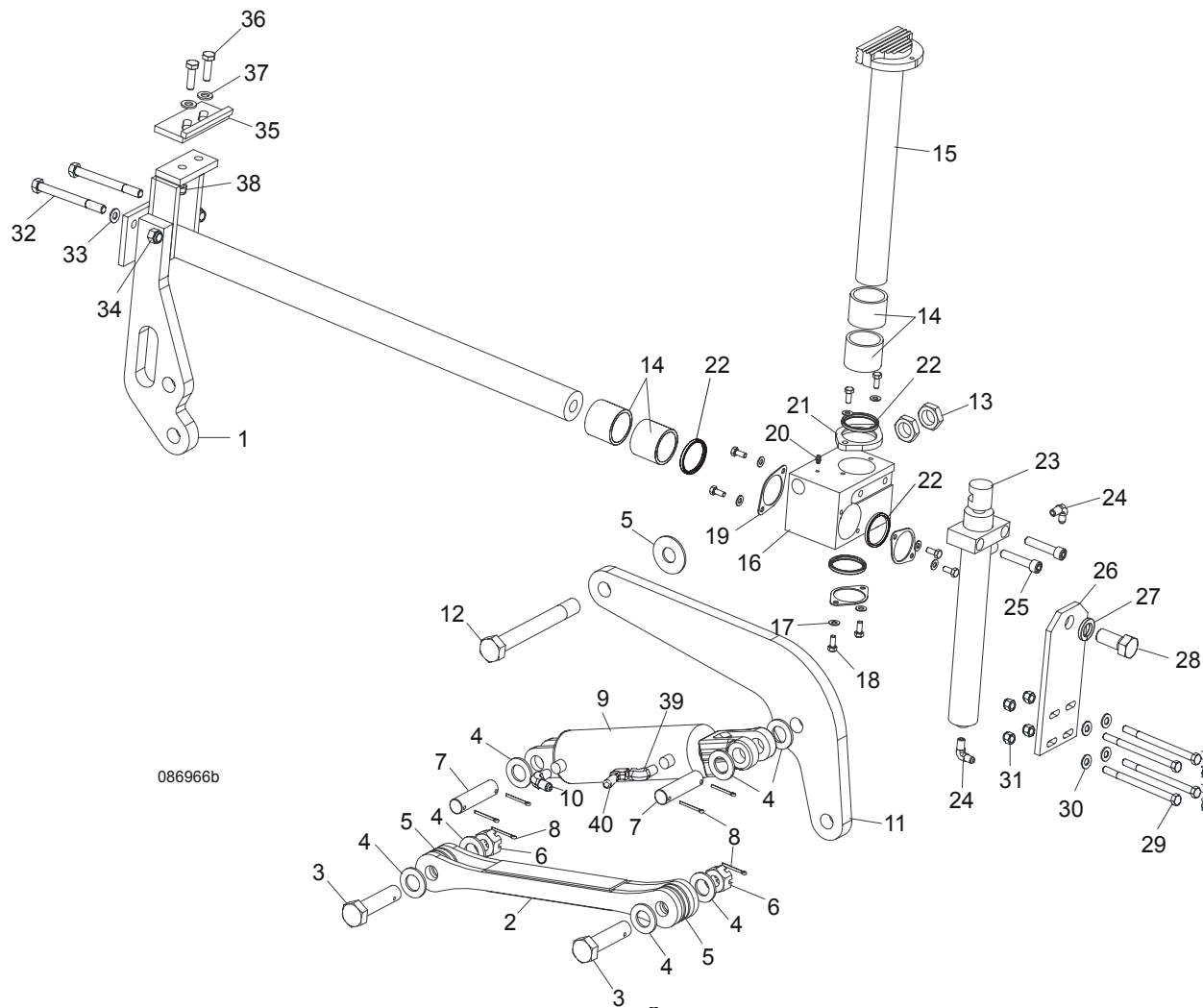

L.P.	OPIS (◆ wskazuje części dostępne jedynie w zespołach)	NUMER KAT.	SZT.
	HYDRAULIC LOG CLAMP ASSEMBLY	088658	1
1	Rod Weldment, Log Clamp Slide Ptd	086967-1	1
2	Arm Weldment, Hydraulic Clamp Link Ptd	086963-1	1
3	Pin, B 24x95/85-Clevis Zinc	F81049-2	1
4	Washer, 25 Flat Zinc	F81061-3	8
5	Washer, 25X63 Zinc-Plated	088585-1	5
6	Nut, Z M20-8-B-Slotted Castle Zinc	F81037-3	2
7	Pin, Hydraulic Cylinder Zinc-Plated	086979-1	2
8	Pin, S-Zn 6,3x45 Cotter	F81045-2	6
9	Cylinder, C,J-S96-16-70/32/178 Hydraulic	088589	1
10	FITTING, 3/8JIC-1/4 NPT STR	015560	1
11	Arm, Hydraulic Log Clamp Link Ptd	086974-1	1
12	Bolt, M24x217/39 -8.8-B- Hex Head Zinc	088586-1	1
13	Nut, M24 -04-B- Hex Thin Zinc	F81039-3	2

14	Bushing, 5040BS Self-Lubricating	088660	2	
15	Rod Weldment, Log Clamp Vertical Painted	088582-1	1	
16	Block, Log Clamp Steel Ptd	088591-1	1	
17	Washer, 8.4 Flat Zinc	F81054-1	8	
18	Bolt, M8x20-8.8-B-Hex Head Full Thread Zinc	F81002-4	8	
19	Flange, Clamp Rod Wiper Ptd	088887-1	3	
20	Fitting, 3/16" Straight Grease	P04107	1	
21	Flange, Clamp Rod Wiper Ptd	088887-1	1	
22	Wiper, ZZ 50x60x7 Log Clamp Rod	088587	1	
23	Cylinder, C,J-S169-16-40/22/254 Hydraulic	088590	1	
	Piston, Hydraulic Cylinder (28mm)	505081-S	1	
24	Fitting, 1/4" NPT - 1/4" JIC Male Elbow	P09142	2	
25	Screw, M12x55 -8.8-B-Hex Socked Head Cap Zinc	F81004-23	2	
26	Plate, Log Clamp Mount Ptd	086975-1	1	
27	Washer, Z 22,5 Split Lock	F81059-4	1	
28	Bolt, M22x1,5x40 -8.8-B-Hex Head Full Thread Zinc	F81009-1	1	
29	Bolt, M10 x 125-8.8 Hex Head Zinc	F81003-18	4	
30	Washer, 10.5 Flat Zinc	F81055-1	8	
31	Nut, M10-8-B Hex Nylon Zinc Lock	F81033-1	4	
32	Bolt, M12x130-8.8-Hex Head Zinc	F81004-36	2	
33	Washer, 13 Flat Zinc	F81056-1	2	
34	Nut, M12-8 Hex Zinc	F81034-1	2	
	STOP KIT, CLAMP	K09485	1	
35	Stop Widmt, Hydraulic Log Clamp Ptd	086980-1	1	
36	Bolt, M12 x 40 8.8 Hex Head Full Thread Zinc	F81004-4	2	
37	Washer, 13 Flat Zinc	F81056-1	2	
38	NUT, M12-8 HEX NYLON ZINC LOCK	F81034-2	4	
39	FITTING, M/F-90-9/16 JIC ELBOW	500597	1	
40	FITTING, 3/8JIC-1/4NPT 90L	015491	1	

9.9 Hydraulic Pull Down Clamp

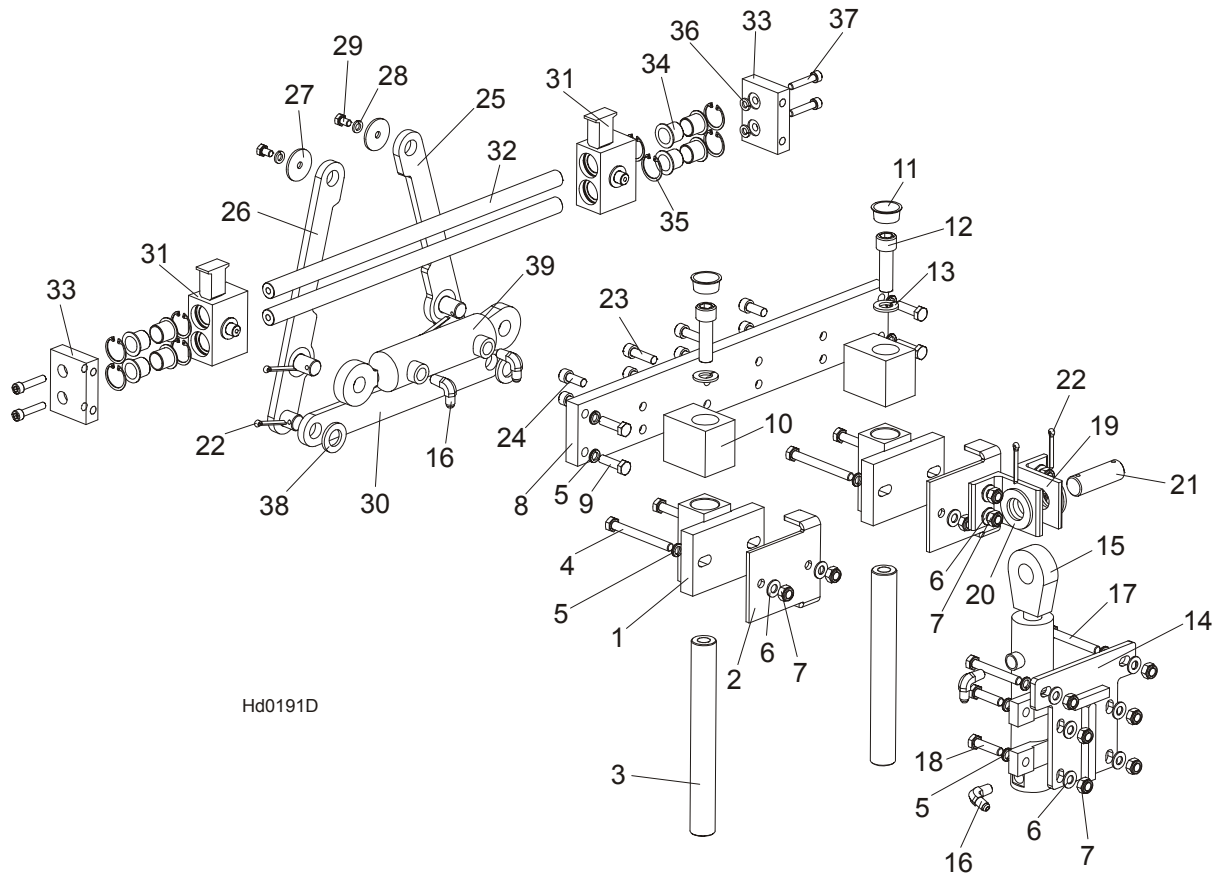

Hd0191D

REF	DESCRIPTION (◆ Indicates Parts Available In Assemblies Only)	PART #	QTY.
	LEFT HYDRAULIC LOG CLAMP ASSEMBLY (REAR)	094129	1
1	Block Weldment, Log Clamp Up/Down Painted	090545-1	2
2	Bracket, Log Clamp Mount Painted	094098-1	2
3	Pin, Log Clamp Up/Down	088631	2
4	Bolt, M10x95-8.8-B Hex Head Zinc	F81003-71	4
5	Washer, 10.2 Split Lock Zinc	F81055-2	14
6	Washer, 10.5 Flat Zinc	F81055-1	14
7	Nut, M10-8-B Hex Nylon Zinc Lock	F81033-1	14
8	Beam, Log Clamp Main Zinc-plated	094115-1	1
9	Bolt, M10x35-8.8 Hex Head Full Thread Zinc	F81003-17	4
10	Block, Log Clamp Up/Down Painted	094124-1	2
11	Plug, M33 Thread #12428	089839	2
12	Screw, M16x55-8.8 Hex Socket Head Cap Zinc	F81006-18	2
13	Washer, 16.3 Split Lock Zinc	F81058-2	2
14	Plate Weldment, Hydraulic Cylinder Mounting Painted	094094-1	1
15	Cylinder, CJ7F-16/40/22 + UE2-40W Hydraulic	091346	1
16	Fitting, 90° Male Elbow	P09142	2

17	Bolt, M10x75-8.8 Hex Head Zinc	F81003-15	2	
18	Bolt, M10x40-8.8 Hex Head Full Thread Zinc	F81003-16	4	
19	Bracket, Hydraulic Cylinder Mounting Painted	094127-1	2	
20	Washer, 28 Flat Zinc	F81061-1	2	
21	Pin, 25X75 Zinc-plated	088659-1	1	
22	Pin, S-Zn 5x40 Cotter Zinc	F81043-31	4	
23	Screw, M10x35 8.8 Hex Socket Head Cap Zinc	F81003-56	4	
24	Screw, M10x25 8.8 Hex Socket Head Cap Zinc	F81003-32	4	
25	Link, Log Clamp In/Out Side Zinc-plated (1)	094097-1	1	
26	Link, Log Clamp In/Out Side Zinc-plated (2)	094099-1	1	
27	Washer, Zinc-plated Spacer	094128-1	1	
28	Washer, 8.2 Split Lock Zinc	F81054-4	2	
29	Bolt, M8x12-8.8 Hex Head Full Thread Zinc	F81002-6	2	
30	Arm, Log Clamp In/Out Zinc-plated	094092-1	1	
31	Jaw Weldment, Log Clamp Zinc-plated	094120-1	2	
32	Rod, Log Clamp Jaw Guide	094116	2	
33	Plate, Locking Zinc-plated	094117-1	2	
34	Bushing, JFM-2023-21 Flanged	094113	8	
35	Ring, W 31 Inside Retaining	F81090-15	8	
36	Washer, 8.2 Split Lock Zinc	F81054-4	4	
37	Screw, M8x40-8.8 Hex Socket Head Cap Zinc	F81002-29	4	
38	Washer, 21 Flat Zinc	F81059-2	2	
39	Cylinder SJ2F-16-40/22/80 Hydraulic	093880	1	

9.10 Hydraulic Toe Board

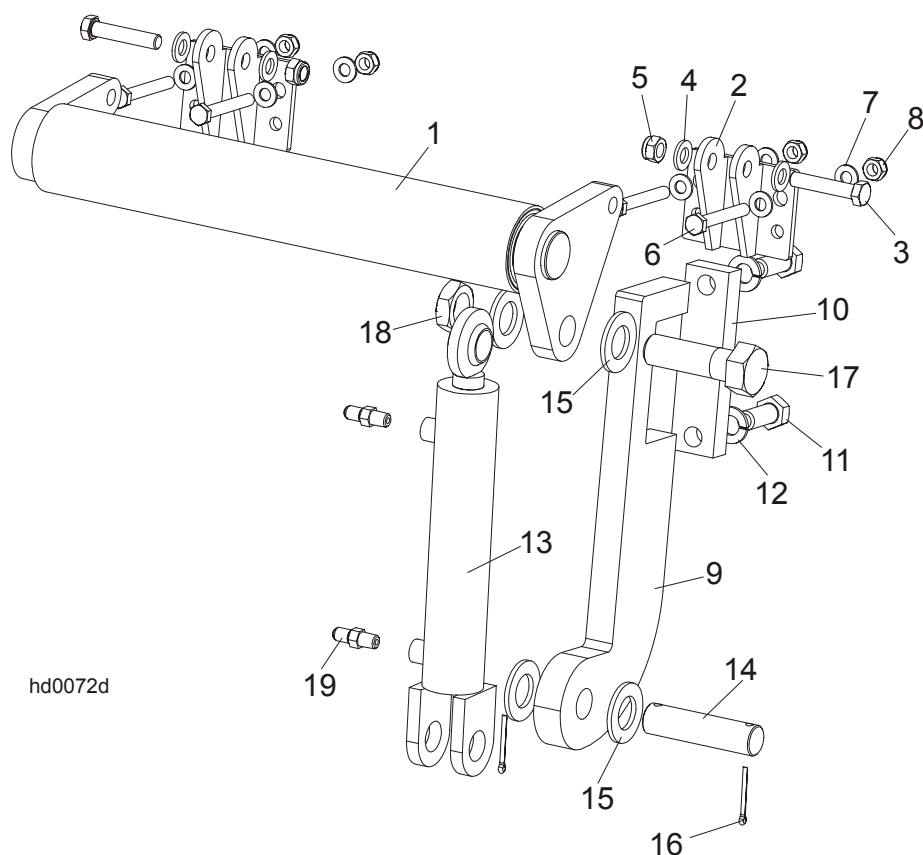

hd0072d

REF	DESCRIPTION (◆ Indicates Parts Available In Assemblies Only)	PART #	QTY.
	FRONT HYDRAULIC TOE BOARD	092613	1
	REAR HYDRAULIC TOE BOARD	092634	1
1	Toe Board Weldment, Front Hydraulic Painted	092612-1	1
	Toe Board Weldment, Rear Hydraulic Painted	086253-1	1
2	Bracket, Toe Board Roller Mount	087903-1	2
3	Bolt, M12x60-8.8 Hex Head Zinc	F81004-5	4
4	Washer, 13 Flat Zinc	F81056-1	8
5	Nut, M12-8 Hex Nylon Zinc Lock	F81034-2	4
6	Bolt, M10x75-8.8 Hex Head Zinc	F81003-15	8
7	Washer, 10.5 Flat Zinc	F81055-1	16
8	Nut, M10-8-B Hex Nylon Zinc Lock	F81033-1	8
9	Bracket, Toe Board Cylinder Mount Painted	087729-1	2
10	Plate, Toe Board Cylinder Mount	090086-1	2
11	Bolt, M16x40-8.8 Hex Head Full Thread Zinc	F81006-13	4
12	Washer, 16.3 Split Lock Zinc	F81058-2	4
13	Cylinder, CJ-S170-16-40/25/152 Hydraulic	088681	2
14	Pin, Hydraulic Cylinder Zinc-Plated	086979-1	2
15	Washer, 28 Flat Zinc	F81061-1	8
16	Pin, 3/16x1.5" Cotter Zinc	F05012-23	4
17	Bolt, 1"-8 x 3 1/4 Hex Head Grade 5	F05009-51	2
18	Nut, 1"-14" Hex Jam Unplated	F05010-117	2
19	Fitting, C5205x4x4 Male	P09143	4