

# **D42 Engine**

## **Safety, Operation, Maintenance & Parts Manual**

---

**LT40 Series MH**  
**LT40 Series DH**

**rev. D1.00**  
**rev. D1.01**

---



**Safety is our #1 concern!** Read and understand all safety information and instructions before operating, setting up or maintaining this machine.

*February 1998*

*Form #916*

# Table of Contents

# Section-Page

## **SECTION 1      OPERATION**

**1-1**

1.1    Starting The Engine .....1-1

## **SECTION 2      MAINTENANCE**

**2-1**

2.1    Safety .....2-1

2.2    Cooling System .....2-2

2.3    Fuel Filter .....2-3

2.4    Battery .....2-4

2.5    Alternator Belt .....2-5

2.6    RPM Adjustments .....2-6

## **SECTION 3      REPLACEMENT PARTS**

**3-1**

3.1    Fuel Tank .....3-1

3.2    Engine Mount Assembly .....3-2

3.3    Engine Assembly .....3-4

3.4    Primary Fuel Filter .....3-6

3.5    Throttle Assembly .....3-7

3.6    Muffler Assembly .....3-9

3.7    Drive Assembly .....3-10

3.8    Radiator Assembly .....3-11

3.9    Alternator Assembly .....3-12

3.10   Engine Pulley Guards .....3-14

## **SECTION 4      ELECTRICAL WIRING DIAGRAMS, D42**

**4-1**

# ABOUT THIS MANUAL

This manual is provided as a supplement to the equipment manufacturer's manuals. This manual provides information specific to the use of this equipment on the Wood-Mizer® sawmill. Refer to the sawmill operator's manual and manufacturer's manual before attempting to operate this equipment.



**IMPORTANT!** Read the sawmill operator's manual and engine manufacturer's manual for instructions and safety precautions before operating this equipment.

The information and instructions given in this manual do not amend or extend the limited warranties for the equipment given at the time of purchase.

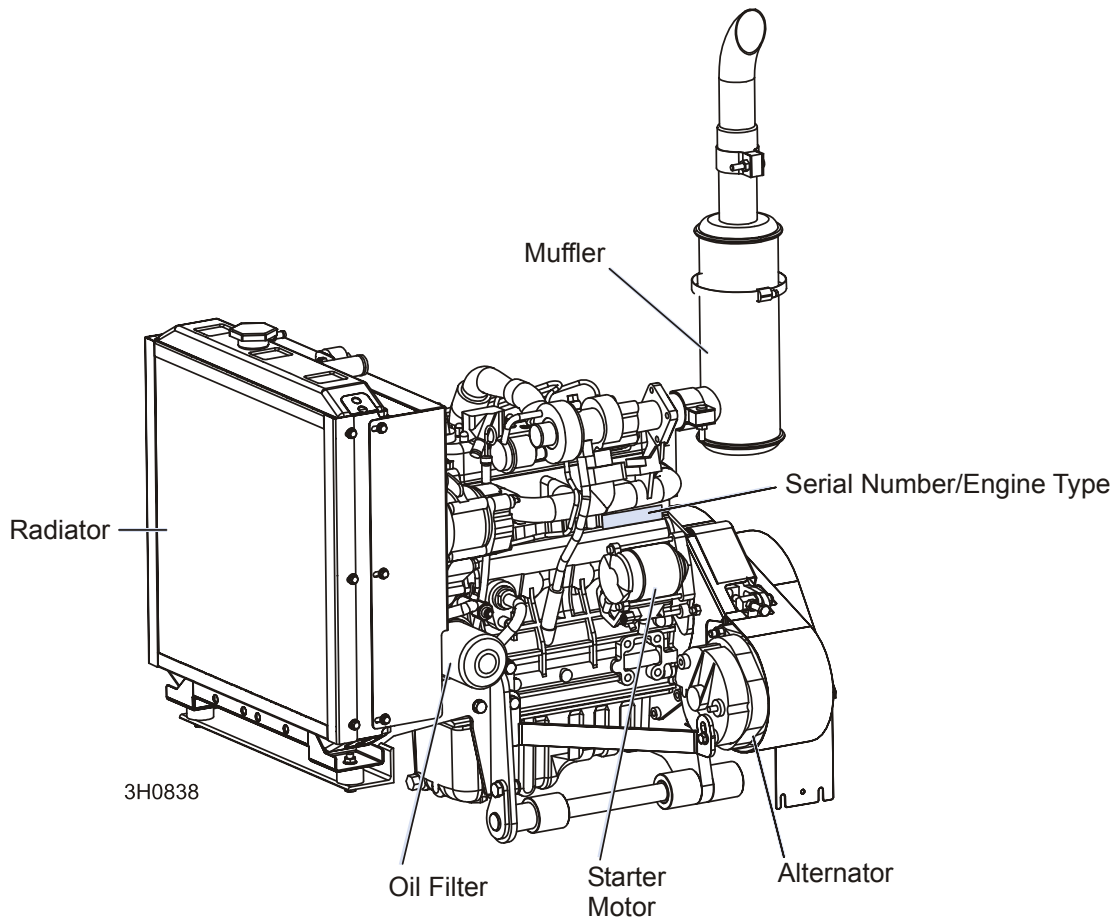

## **ENGINE COMPONENTS**

## SECTION 1 OPERATION

### 1.1 Starting The Engine

#### Control Lights

See Figure 1-1. The following indicator lights are located on the sawmill control panel.

 *Alternator Charge Indicator:* Lights up if the alternator is not charging the battery.



 *Engine Temperature Indicator:* Lights up if the engine is overheating. A circuit breaker assembly in the engine harness will shut the engine off if the engine overheats. Turn the key switch off and allow the engine to cool for a period of time before restarting. If the overheating condition persists, stop operating the engine until the condition is corrected. The engine will automatically switch to low idle if an overheating condition occurs.



 *Key Switch Indicator:* Lights up when the key is in either the on or accessory (#1 or #3) position.



 *Oil Indicator:* Lights up if the oil pressure is too low.



 *Glow Plug Indicator:* Lights up after the key has been turned to the on (#1) position.

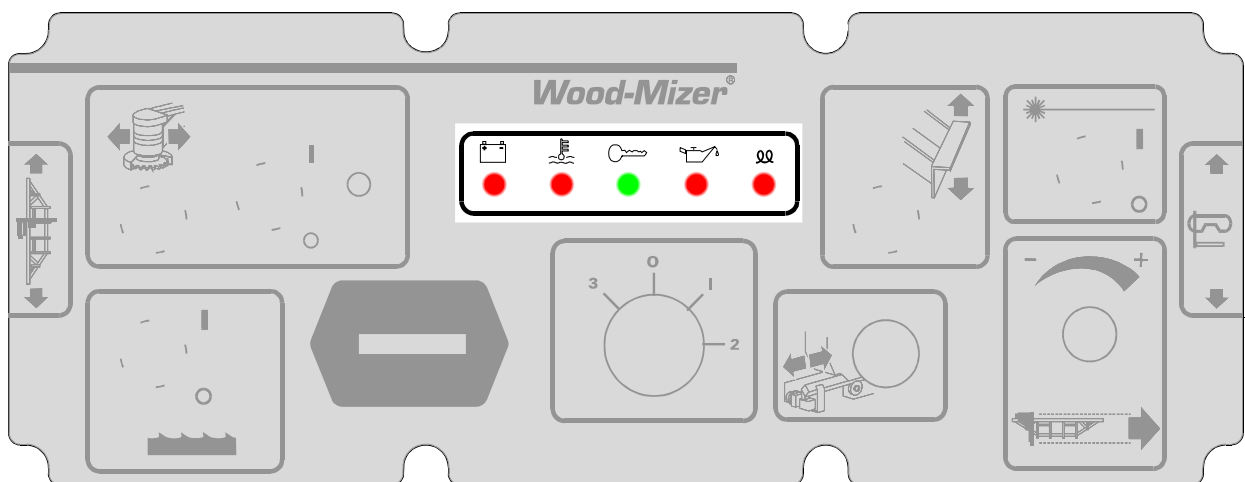

FIG. 1-1

## Engine Start



**DANGER!** Always be sure the blade is disengaged and all persons are out of the path of the blade before starting the engine. Failure to do so will result in serious injury.

**DANGER!** Operate your engine/machine only in well ventilated areas. The exhaust gases of your engine can cause nausea, delirium and potentially death unless adequate ventilation is present.

**DANGER!** Never operate an engine with a fuel or oil leak. The leaking fuel or oil could potentially come in contact with hot surfaces and ignite into flames.



**WARNING!** Be sure the power feed switch is in the neutral position before turning the key switch to the on (#1) or accessory (#3) position. This prevents accidental carriage movement which may cause serious injury or death.

**WARNING!** Do not operate engine without proper and operational spark arrester/muffler. Sparks emitted from the engine exhaust could ignite surrounding materials, causing serious injury or death.



**CAUTION!** Do not crank starter for more than 7 seconds at one time during starting attempts. Damage to the engine may result.

**CAUTION!** Let engine idle for 2 minutes before applying load to prevent engine damage.

1. See the engine manufacturer's manual for lubricating oil recommendations for specific temperature ranges.
2. Use a best quality diesel fuel for below freezing starting.
3. Turn the key switch on the control panel to the on (#1) position.
4. Wait until the glow plug indicator goes out.
5. Turn the key switch to the start (#2) position and release.

# 1 Operation

## *Starting The Engine*

---

### Engine Shutoff



**CAUTION!** A minimum 2 minute idle time is recommended to allow the battery charge to recover before the engine is shut off.

Turn the key switch to the off (#0) position.

## SECTION 2 MAINTENANCE

Refer to the manufacturer's manual for maintenance intervals and procedures unless otherwise instructed in this manual. Follow the manufacturer's recommendations for dusty conditions.



**IMPORTANT!** This manual only provides information about additional procedures or procedures to be performed at different time intervals than found in the manufacturer's manuals. Refer to the manufacturer's manual for complete maintenance instructions.

### 2.1 Safety

Use caution when performing maintenance or service to the engine.



**DANGER!** Always be aware of and take proper protective measures against rotating shafts, pulleys, fans, etc. Always stay a safe distance from rotating members and make sure that loose clothing or long hair does not engage rotating members resulting in possible injury.

**DANGER!** Engine components can become very hot during operation. Avoid contact with any part of a hot engine. The exhaust components of your engine are especially hot during and following operation. Contact with hot engine components can cause serious burns. Therefore, never touch or perform service functions on a hot engine. Allow the engine to cool sufficiently before beginning any service function.



**WARNING!** Remove the blade before performing any engine service. Failure to do so may result in serious injury.

**WARNING!** Always wear proper and necessary safety equipment when performing service functions. Proper safety equipment includes eye protection, breathing protection, hand protection and foot protection.



**This symbol** identifies the interval (hours of operation) at which each maintenance procedure should be performed. "AR" signifies maintenance procedures which should be performed as required.

## 2.2 Cooling System



Clean the radiator fins every 8 hours of operation. Spray the radiator with water from a hose or compressed air to clean sawdust from the radiator fins. Do not use a pressure sprayer.



**CAUTION!** Failure to keep the radiator fins clear of sawdust and/or dirt may cause the engine to overheat resulting in damage to the engine.



### 2.3 Fuel Filter

1500

**See Figure 2-1.** Replace the primary fuel filter cartridge every 1500 hours or one year of operation. After replacing the filter cartridge, loosen the air bleed screw and operate the fuel pump bail until fuel begins to flow from the valve and is free of air bubbles. Tighten the bleed screw. Inspect the water separator bowl periodically and drain the bowl as required by turning the drain cap counterclockwise as viewed from the bottom.

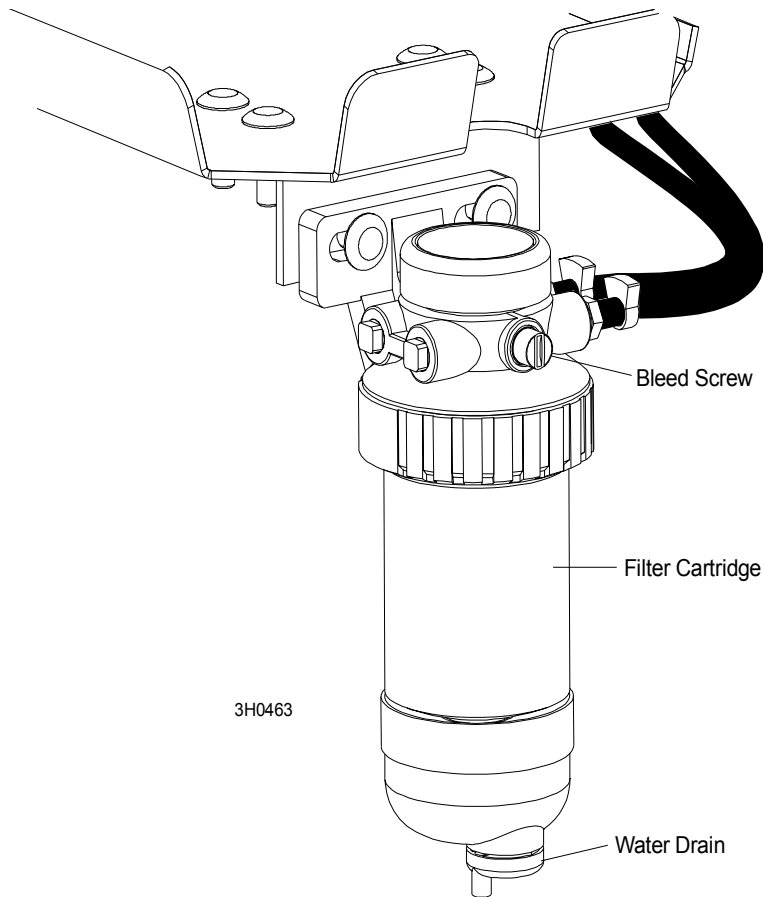

FIG. 2-1

#### 2.4 Battery



Check the battery electrolyte level every 50 hours of operation. See manufacturer's manual for instructions.



**DANGER!** Batteries expel explosive gases. Keep sparks, flames, burning cigarettes, or other ignition sources away at all times. Always wear safety goggles and a face shield when working near batteries. Failure to do so will cause serious injury.<sup>1</sup>



**WARNING!** Battery posts, terminals and related accessories contain lead and lead compounds, chemicals known to the State of California to cause cancer and reproductive harm. Wash hands after handling.

---

1. Battery Council International, copyright 1987

## 2.5 Alternator Belt



The belt tension should be checked after the first 100 hours of operation, when the battery is not charging properly or when the alternator belt is squealing. If the battery continues to not charge properly or the belt continues to squeal after the initial belt adjustment, replace the belt.

1. Release the blade tension and remove the blade from the sawmill if necessary. Turn the key switch to OFF (0) and remove the key.
2. Remove the drive belt cover and alternator cover.

See Figure 2-2.

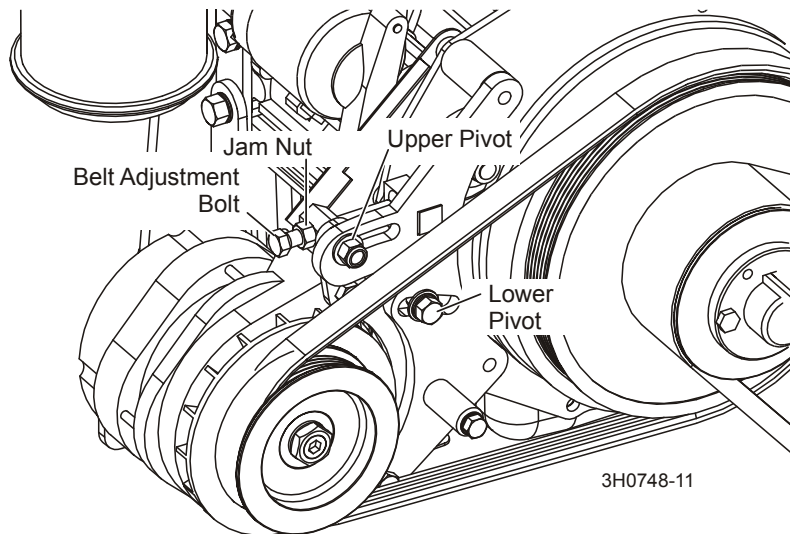

FIG. 2-2

3. Use a belt tension gauge to measure the belt tension. Place the gauge on the belt at the midpoint between the two pulleys. If the belt tension is less than 3/16" with 9 lb. of deflection, tighten the belt as described below.
4. Loosen the upper pivot, lower pivot and the adjustment bolt jam nut.
5. Turn the belt tension adjustment bolt clockwise to tighten the belt, counterclockwise to loosen the belt. Adjust the bolt until the proper belt tension is achieved.



**CAUTION!** Do not overtighten the alternator belt. Damage to the alternator will occur.

6. After the alternator belt has been tensioned, tighten the adjustment bolt jam nut. Tighten the upper and lower pivots and replace the belt covers.

## 2.6 RPM Adjustments



**WARNING!** Remove the blade before performing any engine service. Failure to do so may result in serious injury.



Check the RPM with a tachometer after the first 20 hours of operation and every 200 hours thereafter. High-end RPM should be 3200 RPM and low-end RPM should be 1500 RPM.

Before checking the RPM, make sure belt and brake strap tensions are correct (See Saw-mill Maintenance). Also check oil, fuel, and coolant levels.

Make sure the throttle cable does not affect the engine RPM when the clutch handle is disengaged. Make sure the cable is not bent or kinked.

1. Use the bottom threaded cable mount to adjust the throttle cable. When the clutch handle is disengaged, the throttle cable should be taut but the spring not extended. When the clutch handle is engaged, the throttle spring should extend 1/8" to 1/4". Once the throttle cable is adjusted properly, use the adjustments provided on the engine to adjust the engine RPM (3200[+0, -100] high-end, 1500[±100] idle).



**CAUTION!** Do not extend the throttle spring over 1/4". Excessive tension may cause the throttle cable to fail prematurely.

See Figure 2-3.

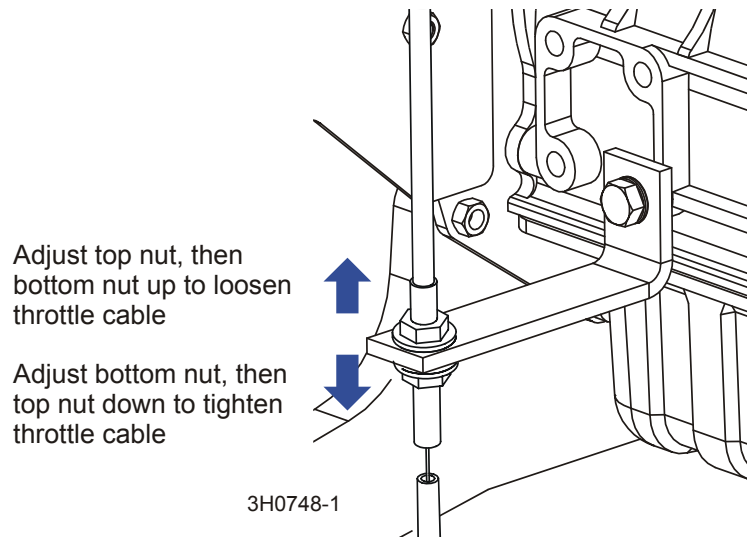

FIG. 2-3

2. Start the engine to measure the low-end RPM. Let idle for 10 minutes.
3. With the engine at idle, check the low-end RPM. Adjust to 1500. To decrease speed, loosen the idle adjustment screw. To increase speed, tighten the idle adjustment screw.

See Figure 2-4.

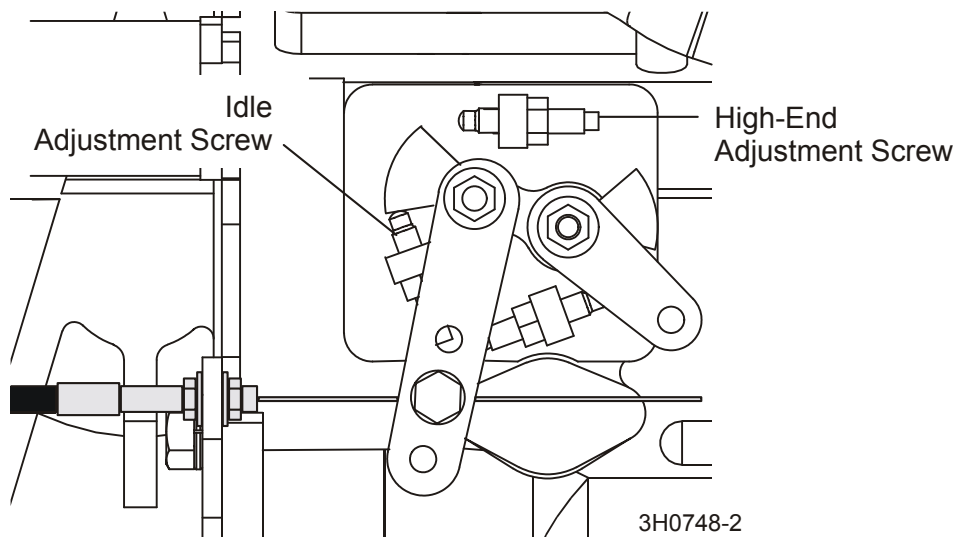

FIG. 2-4

4. Adjust the high-end RPM to 3200. To decrease speed, tighten the high-end adjustment screw. To increase speed, loosen the high-end adjustment screw.



**CAUTION!** Do not adjust the high-end RPM above 3200. Doing so may cause damage to the engine.

5. After the RPM settings are made, shut the engine off. Tighten the throttle cable by engaging the clutch handle. Check the throttle cable at the upper cable mounting bracket. The cable should be centered in the cable housing. If necessary, loosen the upper bracket mounting bolts and adjust the bracket so the cable housing is centered around the cable. Retighten the upper cable bracket mounting bolts.

See Figure 2-5.

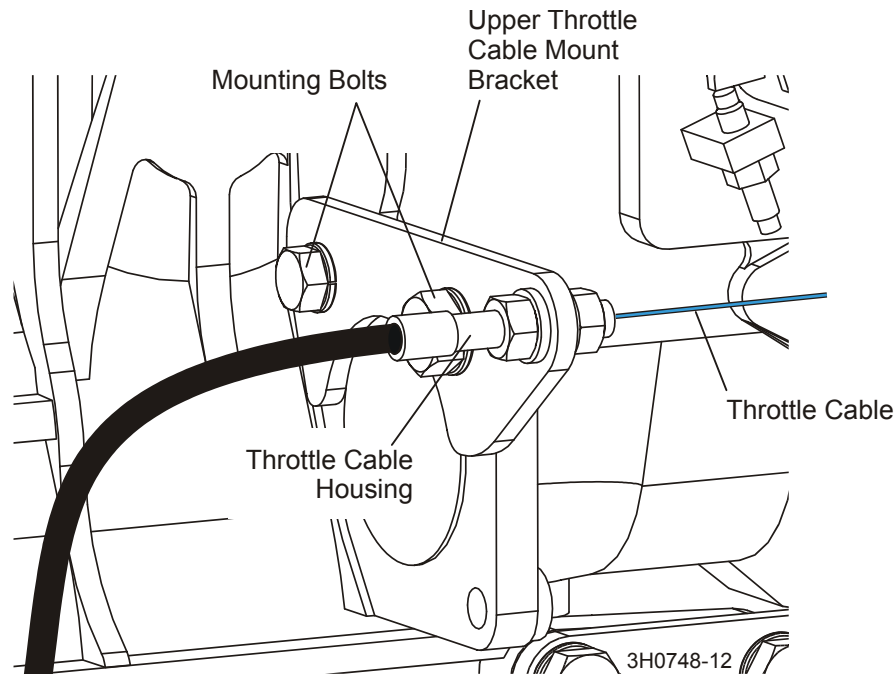

FIG. 2-5



**CAUTION!** Failure to properly center the throttle cable in the cable housing may result in premature cable wear.

## SECTION 3 REPLACEMENT PARTS

### 3.1 Fuel Tank

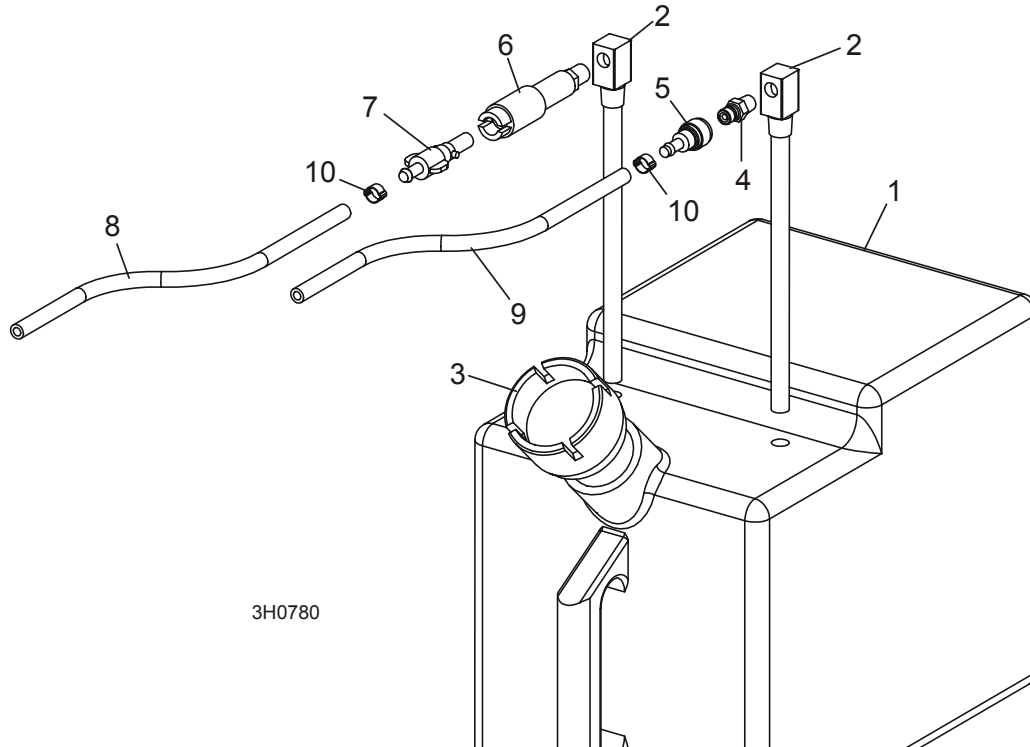

REF	DESCRIPTION (◆ Indicates Parts Available In Assemblies Only)	PART #	QTY.	
	<b>TANK ASSEMBLY, 5 GALLON GREEN DIESEL</b>	A12132	1	
1	Tank, 5 Gallon Green Fuel	P12166	1	◆
2	Pickup, 9" Fuel	P12172	2	
3	Cap, 3/5 Gallon Fuel Tank	P09683	1	
4	Fitting, 1/4" NPT Male Quick Disconnect	015583	1	
5	Fitting, Female Quick Disconnect Barb	015582	1	
6	Fitting, 1/4" NPT Plastic Female Disconnect	P12175	1	
7	Fitting, 1/4" Barb Plastic Male Disconnect	P12176	1	
8	<b>HOSE, 1/4" ID FUEL</b>	P642	7.17 Ft	
9	<b>HOSE, 5/16" ID FUEL</b>	016338	9 Ft.	
10	<b>CLAMP, 7/32 - 1/2 HOSE</b>	P649	6	
	<b>ADDITIVE, DIESEL FUEL 16OZ BOTTLE</b>	004878 <sup>1</sup>	1	

<sup>1</sup> Stanadyne Performance Formula helps eliminate contaminants and water in fuel, prevents gelling in cold weather, and improves lubrication of fuel system parts. 16 oz. bottle treats 60 gallons of diesel fuel.

# 3 Replacement Parts

## Engine Mount Assembly

### 3.2 Engine Mount Assembly

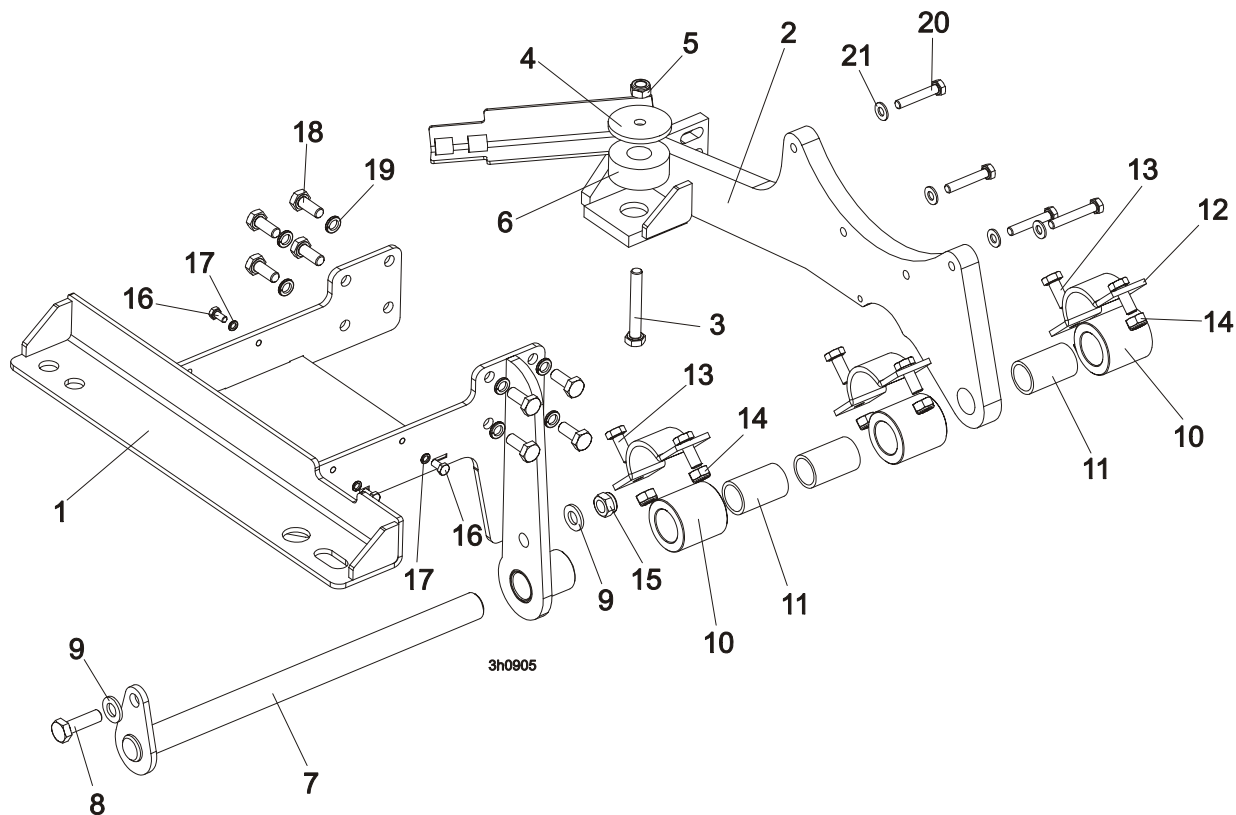

REF	DESCRIPTION (◆ Indicates Parts Available In Assemblies Only)	PART #	QTY.
1	<b>MOUNT WELDMENT, FRONT KUBOTA ENGINE</b>	087947-1	1
2	<b>MOUNT WELDMENT, REAR KUBOTA ENGINE</b>	087945-1	1
	VIBRATION ABSORBER, CLUTCH	090666-1	1
3	<b>Bolt, M10X70-8.8 HEX HEAD, ZINC</b>	F81003-20	1
4	<b>Washer, 3/8" I.D. X 2 1/4" O.D. X 3/16" THICK</b>	S12412-0	1
5	<b>Nut, M10-8-B Hex Nylon Lock</b>	F81033-1	1
6	<b>BUSHING, MOTOR MOUNT VIBRATION</b>	P05032	1
7	<b>PIN WELDMENT, KUBOTA ENGINE MOUNT PIVOT</b>	087955-1	1
8	BOLT, M12 X 40-8.8 HEX HEAD	F81004-4	1
9	WASHER, 13 FLAT ZINC	F81056-1	1
	<b>BUSHING ASSEMBLY, MOTOR MOUNT</b>	016380	3
10	Bushing, 2" OD x 2"	016378	1
11	Bearing, 1" x 1 1/4" x 2"	016379	1
12	<b>CLAMP WELDMENT, MOTOR MOUNT</b>	086200	1
13	BOLT, M10-1.5X25MM HH GR8.8	F81003-11	1
14	<b>NUT, M10, NYLON HEX ZINC LOCK</b>	F81033-1	2
15	NUT, M12-8-B NYLON LOCK	F81034-2	1
16	BOLT M6x12-8.8-Fe/Zn5	F81001-7	4



<b>17</b>	WASHER, 10.2 SPLIT LOCK ZINC	F81053-3	4	
<b>18</b>	BOLT M10x1,25x25-8.8-A-Fe/Zn5	F81003-29	8	
<b>19</b>	WASHER, 10.2 SPLIT LOCK ZINC	F81055-2	8	
<b>20</b>	BOLT, M8X45 - 8.8 HEX HEAD GRADE 5	F81002-14	4	
<b>21</b>	WASHER, M8, FLAT ZINC	F81054-1	4	

# 3 Replacement Parts

## Engine Assembly

### 3.3 Engine Assembly

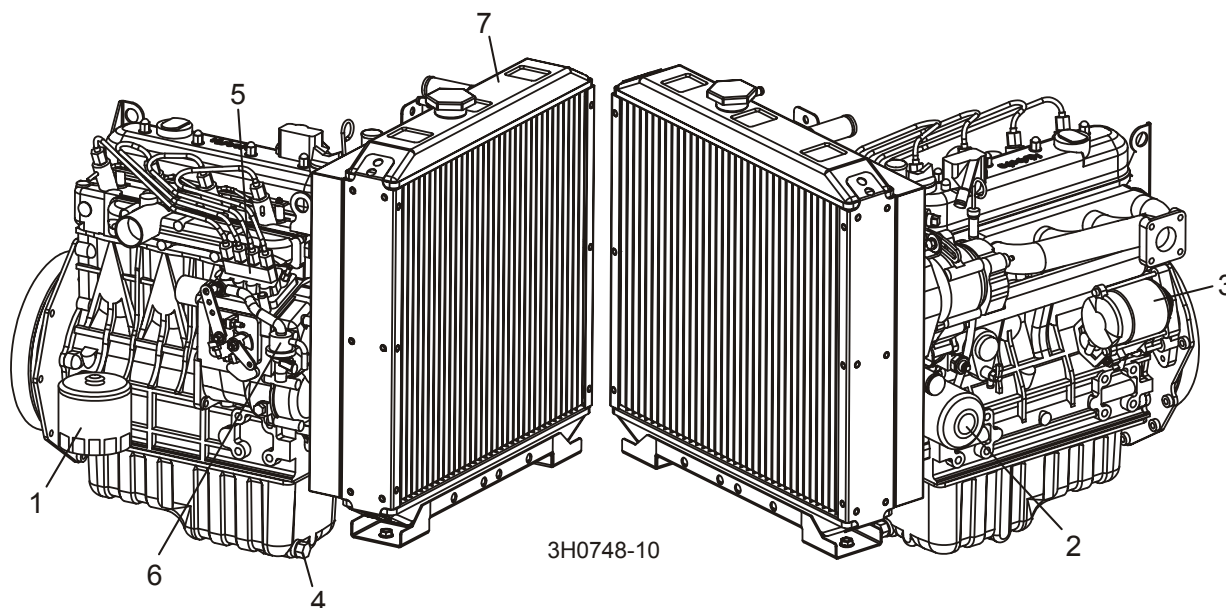

REF	DESCRIPTION (◆ Indicates Parts Available In Assemblies Only)	PART #	QTY.
	<b>ENGINE, KUBOTA 1505TE</b>	088022	1
	Belt, Kubota Fan #16282-97010	028514	1
	Filter, Kubota D42 Air B53/207(16617-11001)	088025	1
1	Filter, Kubota D42 fuel D52/184(16616-43001)	088024	1
	Filter, Kubota Fuel 16616-43001(D52/184)	028560	1
2	Filter, Kubota Oil #16271-32090	018050	1
	Gasket Kit, Kubota Lower #07916-29265	028519	1
	Gasket Kit, Kubota Upper #16285-99352	028572	1
	Gasket, Kubota Exhaust #15263-12370	028513	1
	Gasket, Kubota Fuel Injector #15841-53622	028516	1
	Gasket, Kubota Fuel Transfer Pump #16264-52140	028518	1
	Gasket, Kubota Head #16292-03310	028571	1
	Gasket, Kubota Muffler #15263-12371	028549	1
	Gasket, Kubota Oil Drain Plug #15451-96670	028543	1
	Gasket, Kubota Stop Solenoid #16299-60150	028544	1
	Gasket, Kubota Thermostat #15313-7320	028545	1
	Gasket, Kubota Valve Cover #16241-14520	028524	1
	Gasket, Kubota Water Pump #16259-73430	028526	1
	Glow Plug, Kubota #16851-65510	028562	1
	Injector, Kubota Fuel #16032-53000	028515	1
3	Motor, Kubota Starter #37560-63010	028522	1

<b>4</b>	Plug, Kubota Oil Drain #16541-33750	028542	1	
<b>5</b>	Pump, Kubota Fuel Injector #16060-51010	028540	1	
<b>6</b>	Pump, Kubota Fuel Transfer #16285-52032	028517	1	
	Pump, Kubota Water #16241-73032	028525	1	
<b>7</b>	Radiator Parts ( <a href="#">See Section 3.8</a> )			
	Sending Unit, Kubota Heat Sensor #TM9A230RQCG	028510	1	
	Solenoid, Kubota Stop #17454-60010	028523	1	
	Switch, Kubota Oil Pressure #15841-39010	028547	1	
	Thermostat, Kubota #19434-73010	028546	1	
	<b>HARNESS ASSEMBLY, KUBOTA DIESEL ENGINE</b>	024594	1	
	Breaker Assembly, Water Temp Max Circuit	024453	1	
	Socket, Glow Plug Relay w/Fuse Holder	024554	1	
	Fuse Link, 50 Amp	024597	1	
	Relay, Glow Plug	088143	1	

# 3 Replacement Parts

## Primary Fuel Filter

### 3.4 Primary Fuel Filter

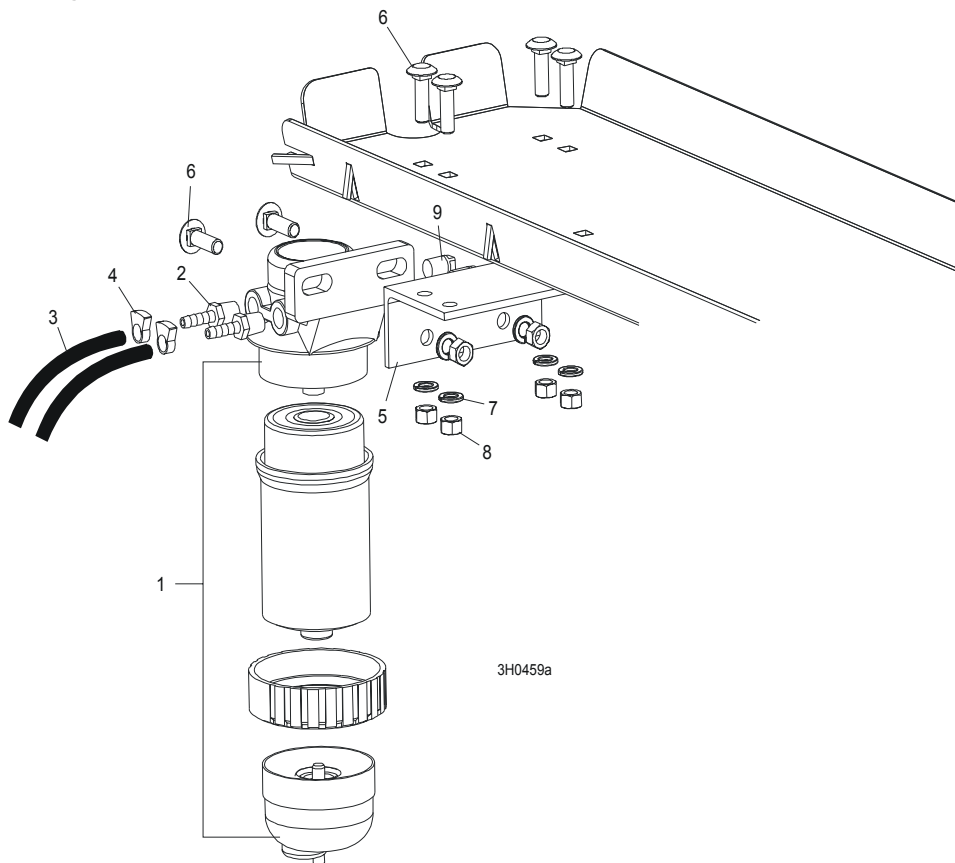

REF	DESCRIPTION (◆ Indicates Parts Available In Assemblies Only)	PART #	QTY.
1	<b>FILTER ASSEMBLY, STANDADYNE FUEL FPV-5,7 04WP40/3</b>	088101	1
2	<b>FITTING, 3.4/3, 8MM, FILTR FPV-5,7</b>	088094	2
3	<b>HOSE, 5/16" ID FUEL</b>	R80703-2	9 Ft
4	<b>CLAMP, 11-17MM HOSE</b>	F81080-3	2
5	<b>BRACKET, DIESEL FUEL FILTER MOUNT</b>	015905	1
6	<b>BOLT, 3/8-16 X 1 1/4" CARRIAGE HEAD</b>	F05007-11	6
7	<b>WASHER, 3/8" SPLIT LOCK</b>	F05011-4	6
8	<b>NUT, 3/8-16 HEX</b>	F05010-1	6
9	<b>FITTING, 1/4" NPT PLUG</b>	P05498	2

### 3.5 Throttle Assembly

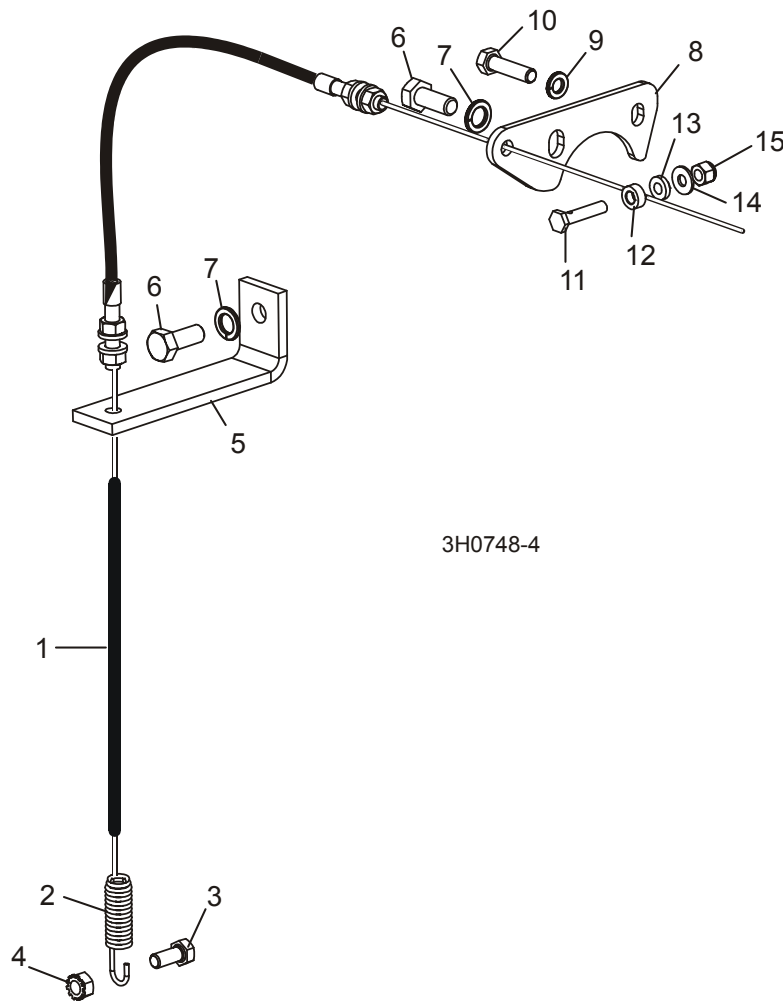

3H0748-4

REF	DESCRIPTION (◆ Indicates Parts Available In Assemblies Only)	PART #	QTY.
1	CABLE, KUBOTA THROTTLE	015857	1
2	Spring, Throttle	016033	1
3	BOLT, 5/16-18 X 3/4" HEX HEAD	F05006-5	1
4	NUT, 5/16-18 HEX SELF-LOCKING	F05010-20	1
5	BRACKET, LOWER THROTTLE CABLE MOUNT	015853	1
6	BOLT, M10-1.5 X 25MM HEX HEAD FULL THREAD GRADE 5	F05009-52	2
7	WASHER, 10MM SPLIT LOCK	F05011-88	2
8	BRACKET, UPPER THROTTLE CABLE MOUNT	019009	1
9	WASHER, 5/16" SPLIT LOCK	F05011-13	1
10	BOLT, M8-1.25 X 1" HEX HEAD	F05004-40	1
11	BOLT, THROTTLE CABLE	015985	1
12	WASHER, .266 X .50 X .28 AL-BRONZE	015986	1

### **3** Replacement Parts

*Throttle Assembly*

---

13	BOSS, 1/4 X 1/2 X .26" AL-BRONZE	016339	1	
14	WASHER, .25ID X .62OD X .06THK, PLATED	016175	1	
15	NUT, 1/4-20 NYLON LOCK	F05010-69	1	
16	NUT, 1/4-20 NYLON LOCK	F05010-69	1	
17	NUT, 5/16-18 SELF-LOCKING HEX	F05010-20	1	
18	BOLT, 5/16-18 X 1 1/4" HEX HEAD FULL THREAD	F05006-18	1	
19	NUT, 5/16-18 HEX LOCK	F05010-6	1	

### 3.6 Muffler Assembly

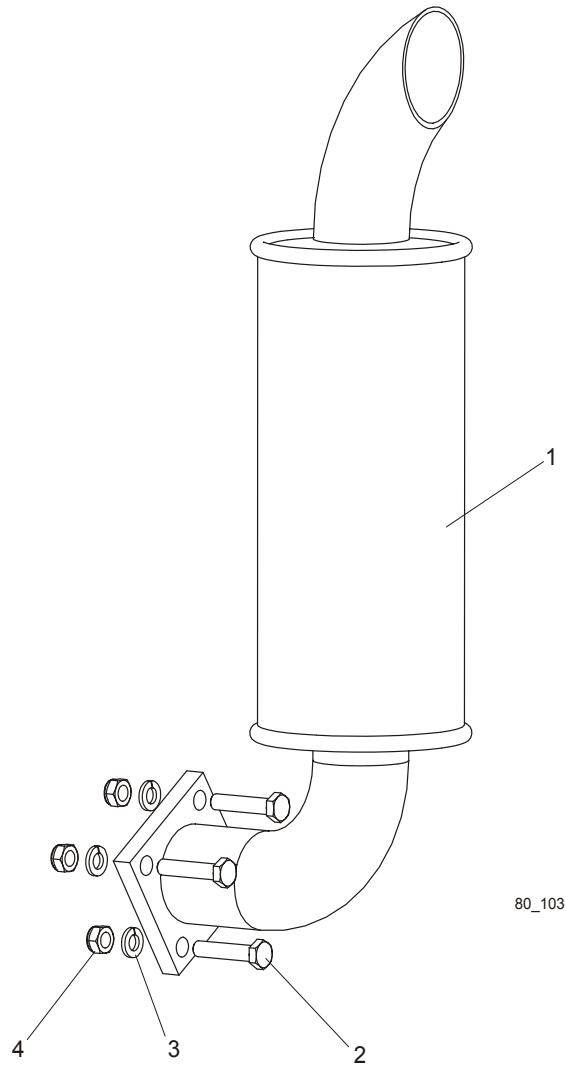

REF	DESCRIPTION (◆ Indicates Parts Available In Assemblies Only)	PART #	QTY.	
1	MUFFLER, KUBOTA ENGINE	088100	1	
2	BOLT, M8X40-8.8 HEX HEAD FULL THREAD ZINC	F81002-15	4	
3	WASHER, 8.2 ZINC SPLIT LOCK	F81054-4	4	
4	NUT, M8 HEX WELD	F81032-3	4	

# 3 Replacement Parts

## Drive Assembly

### 3.7 Drive Assembly

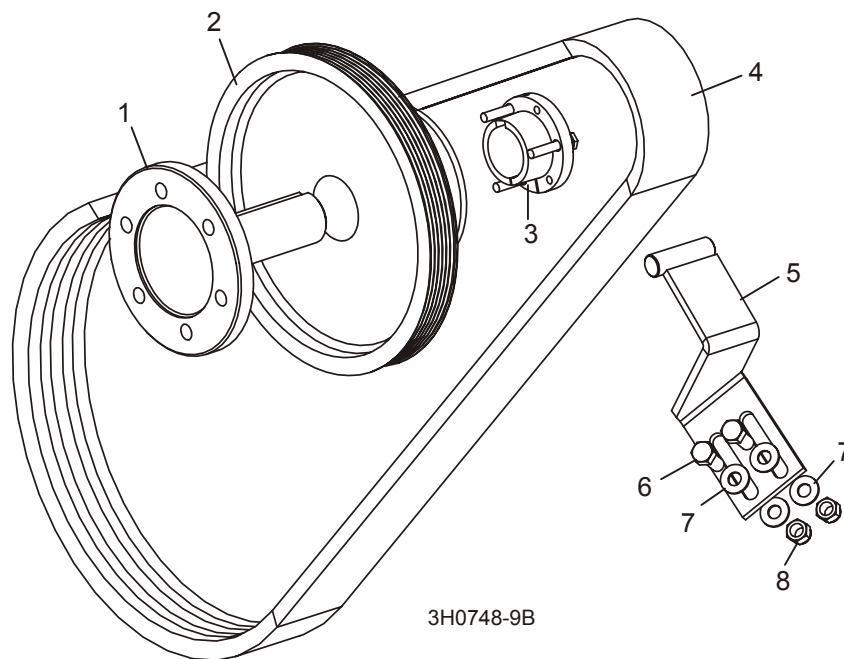

REF	DESCRIPTION (◆ Indicates Parts Available In Assemblies Only)	PART #	QTY.
1	SHAFT, KUBOTA POWER	087953	1
2	SHEAVE, 5V X 4.46" POLY V (GAS/DIESEL)	085921	1
3	BUSHING, SH X 1 7/16"	085714	1
4	BELT, 3BX72	014085	1
5	BRACKET, DRIVE BELT SUPPORT	016364	1
6	BOLT, 3/8-16 X 1" HEX HEAD	F05007-7	2
7	WASHER, 3/8" SAE FLAT	F05011-3	4
8	NUT, 3/8-16 HEX NYLON LOCK	F05010-10	2



### 3.8 Radiator Assembly

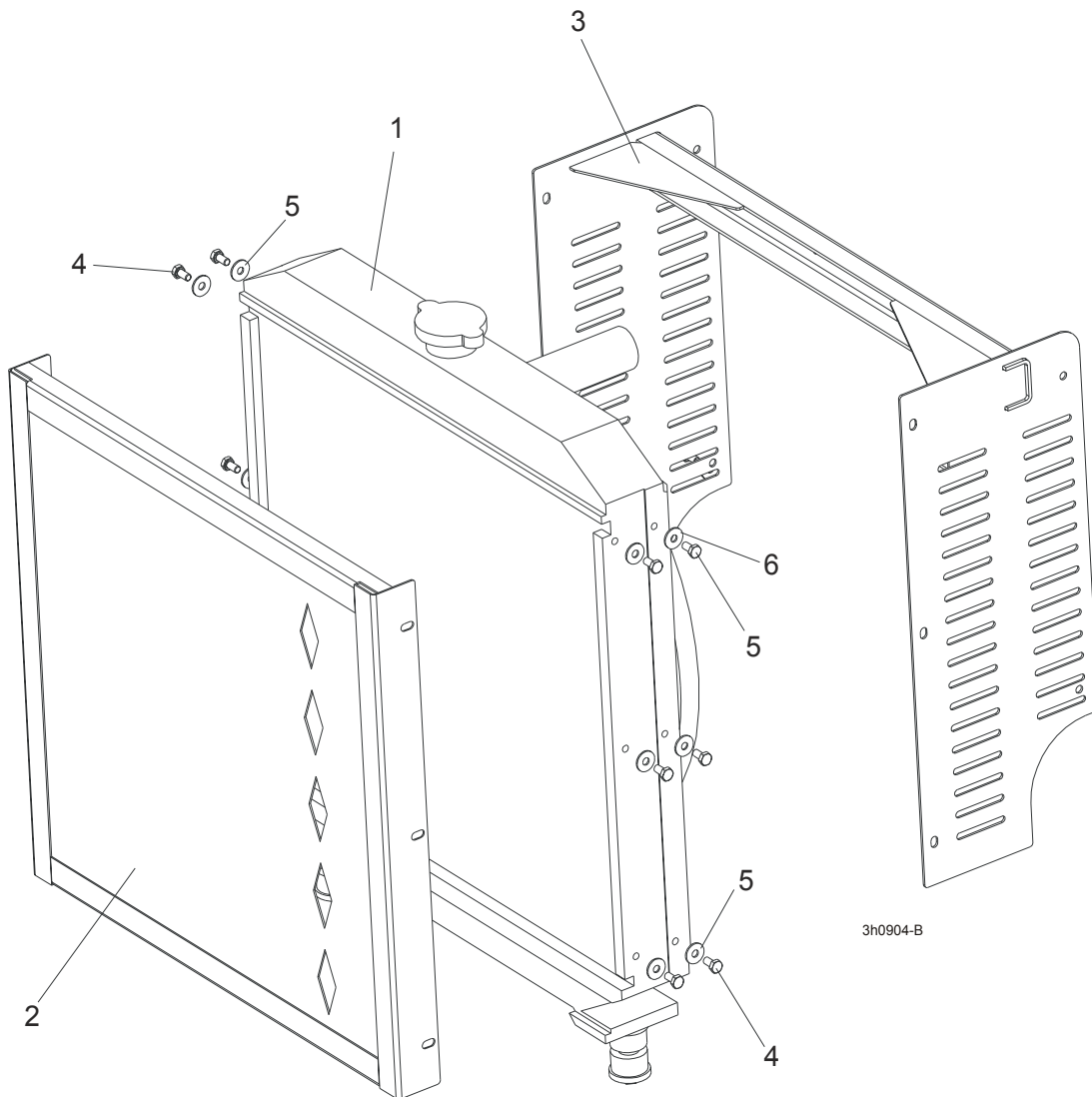

REF	DESCRIPTION (◆ Indicates Parts Available In Assemblies Only)	PART #	QTY.
1	<b>RADIATOR ASSEMBLY, D42 A21/349(16292-72001)</b>	088023	1
2	GUARD, KUBOTA RADIATOR FRONT	087967-1	1
3	<b>BRACKET, RADIATOR MOUNT</b>	088083-1	1
4	BOLT, M6X12-8.8 HEX HEAD FULL THREAD ZINC	F81001-7	12
5	<b>WASHER, 6.5 FLAT ZINC</b>	F81053-11	12

# 3 Replacement Parts

## Alternator Assembly

### 3.9 Alternator Assembly

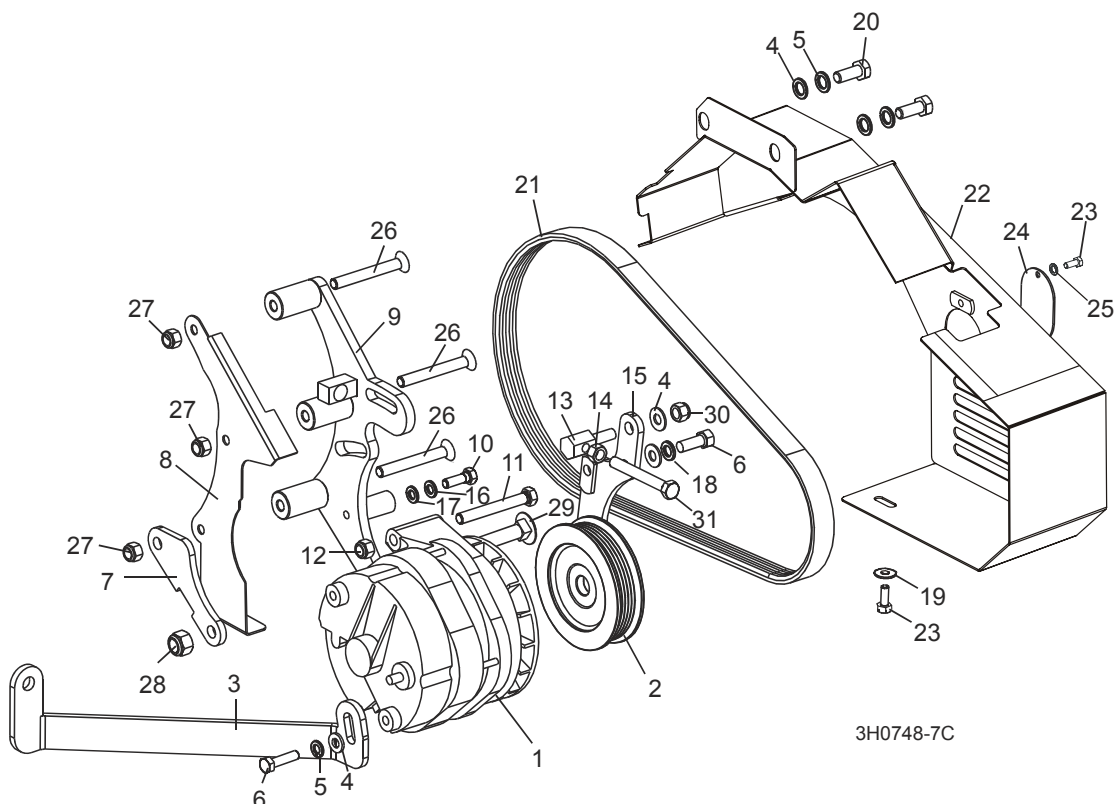

REF	DESCRIPTION (◆ Indicates Parts Available In Assemblies Only)	PART #	QTY.	
	<b>WIRE ASSEMBLY, 61/140 AMP ALTERNATOR PLUG</b>	015969	1	
	<b>ALTERNATOR ASSEMBLY, 140 AMP</b>	023730	1	◆
1	Alternator, 140 Amp	023695	1	
2	Pulley, 140 Amp Alternator	023694	1	
3	<b>BRACKET, ALTERNATOR SUPPORT</b>	015923	1	
4	<b>WASHER, 10.5 SAE FLAT</b>	F81055-1	3	
5	<b>WASHER, 10.2 SPLIT LOCK</b>	F81055-2	3	
6	<b>BOLT, M10X25 8.8 HEX HEAD</b>	F81003-11	1	
7	<b>PLATE, REAR ALTERNATOR MOUNT</b>	091676-1	1	
8	<b>GUARD WELDMENT, REAR ALTERNATOR</b>	091678-1	1	
9	<b>BRACKET WELDMENT, ALTERNATOR MOUNT</b>	091675-1	1	
10	<b>BOLT, M10X20 8.8 HEX HEAD</b>	F81002-4	1	
11	<b>BOLT, 3/8-16 X 3" HEX HEAD FULL THREAD</b>	F05007-1	2	
12	<b>NUT, 3/8-16 HEX NYLON LOCK</b>	F05010-10	1	
13	<b>STUD, ALTERNATOR BELT TENSION ADJUSTMENT</b>	091694-1	1	
14	<b>NUT, M10-8-B</b>	F81033-3	1	
15	<b>PLATE WELDMENT, ALTERNATOR PIVOT</b>	091678-1	1	

16	WASHER, 8.2 SPLIT LOCK	F81054-4	1	
17	WASHER, 8.4 SAE FLAT	F81054-1	1	
18	WASHER, 10.2 SPLIT LOCK	F81055-2	1	
19	WASHER, 6.5 SAE FLAT	F81053-11	1	
20	BOLT, M10 X 1.25 X 25MM HEX HEAD	F81003-29	2	
21	BELT, 6PK1080 FIBERGLASS ALTERNATOR	088181	1	
22	GUARD WELDMENT, ALTERNATOR BELT	093470-1	1	
23	BOLT, M6X12-8.8 HEX HEAD	F81001-7	2	
24	PLATE, ALTERNATOR BELT ACCESS COVER	093367-1	1	
25	WASHER, 6.4 SAE FLAT	F81053-1	1	
26	BOLT, M8 X 90 8.8 FLAT HEAD CAP GRADE 8	F81002-92	3	
27	NUT, M8-8-B FREE ZINC PLATE	F81032-2	3	
28	NUT, 3/8-16 HEX NYLON LOCK	F05010-10	1	
29	BOLT, 3/8-16 X 3 1/2" CARRIAGE HEAD BOLT	F05007-161	1	
30	NUT, M10-8-B HEX NYLON LOCK	F81033-1	1	
31	BOLT, M10X70-8.8 HEX HEAD	F81003-20	1	

# 3 Replacement Parts

## Engine Pulley Guards

### 3.10 Engine Pulley Guards

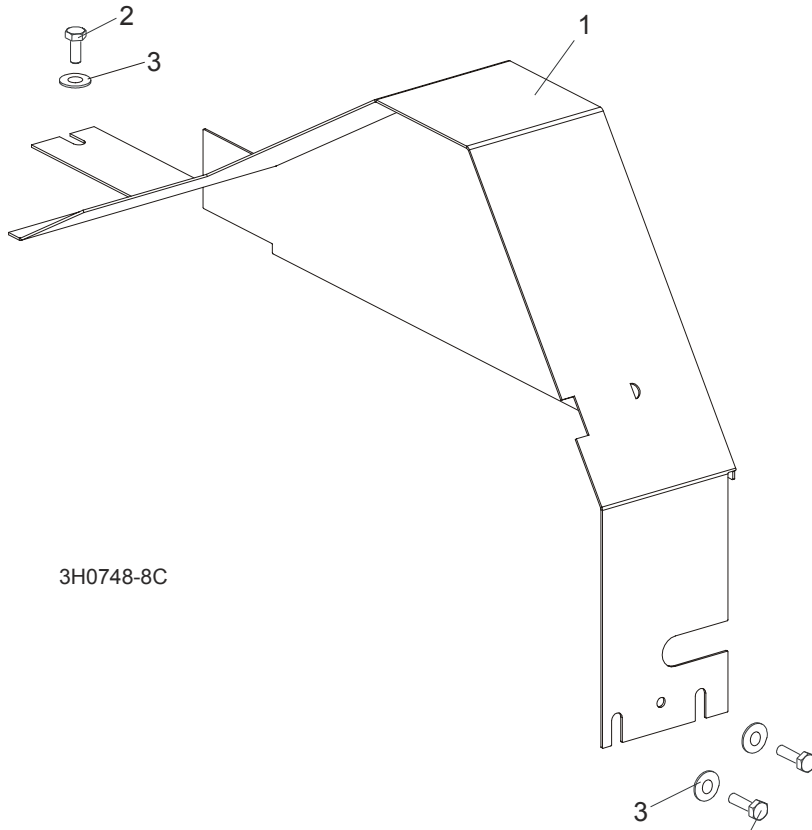

REF	DESCRIPTION (◆ Indicates Parts Available In Assemblies Only)	PART #	QTY.	
1	GUARD WELDMENT, KUBOTA ENGINE PULLEY	095086-1	1	
2	BOLT, M6x12-8.8 HEX HEAD	F81001-7	3	
3	WASHER, 6,5	F81053-11	3	

---

## SECTION 4 ELECTRICAL WIRING DIAGRAMS, D42



**IMPORTANT!** When using a sawmill with the rewired control panel it is very important not to switch between saw head forward/backward movement until the saw head stops. Failure to do so may result in serious sawmill damage.



**WARNING!** When using the variable reverse speed wiring it is recommended that the operator should stop the head, turn the potentiometer to zero, engage reverse and then increase speed. Failure to do this may result in damage to the circuit. There is a protection in the circuit and if this is activated it will not allow the head to start the return movement until the potentiometer is set to zero.

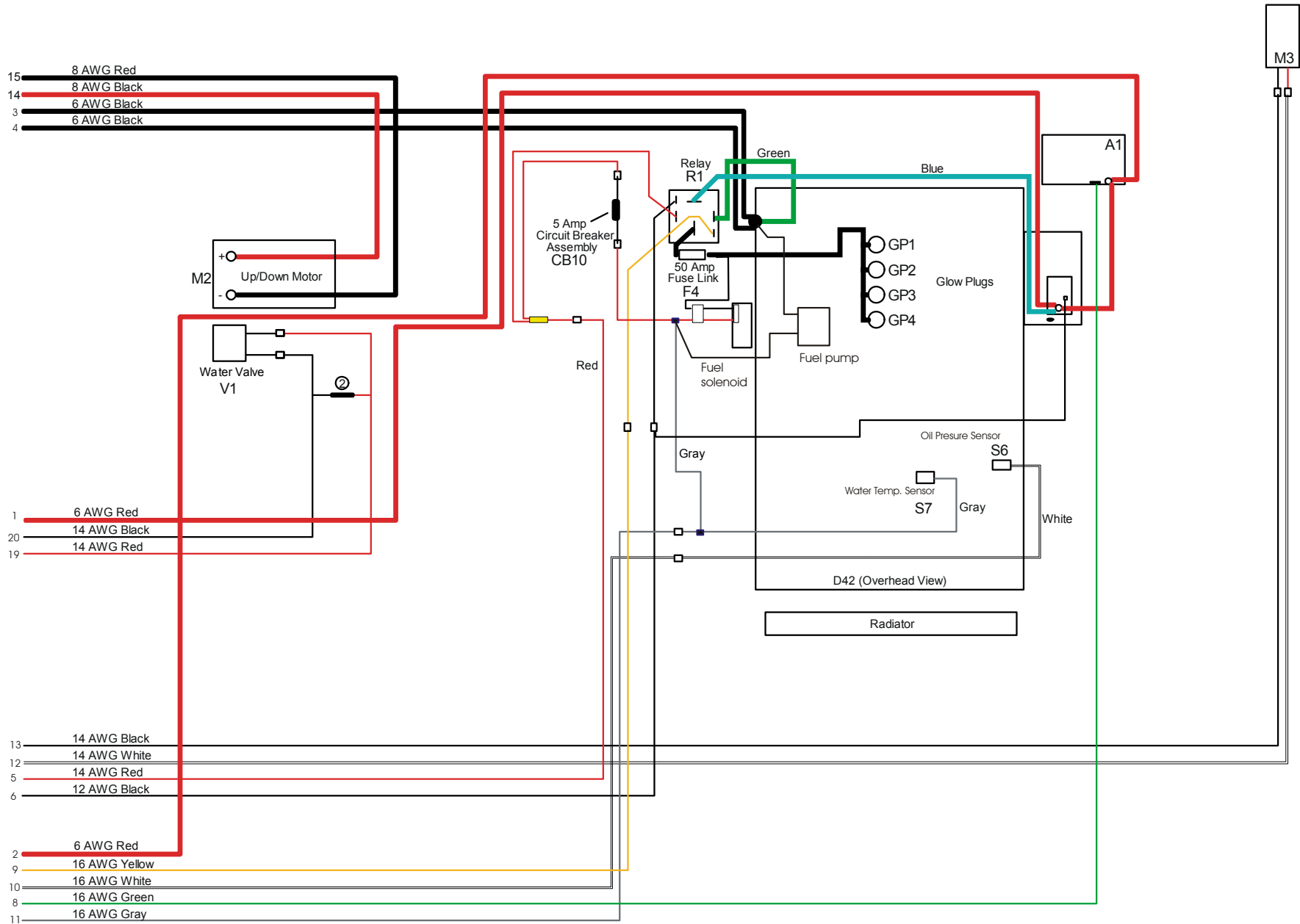

FIG. 4-1 D42 WIRING DIAGRAM (LT40 SAWMILLS).

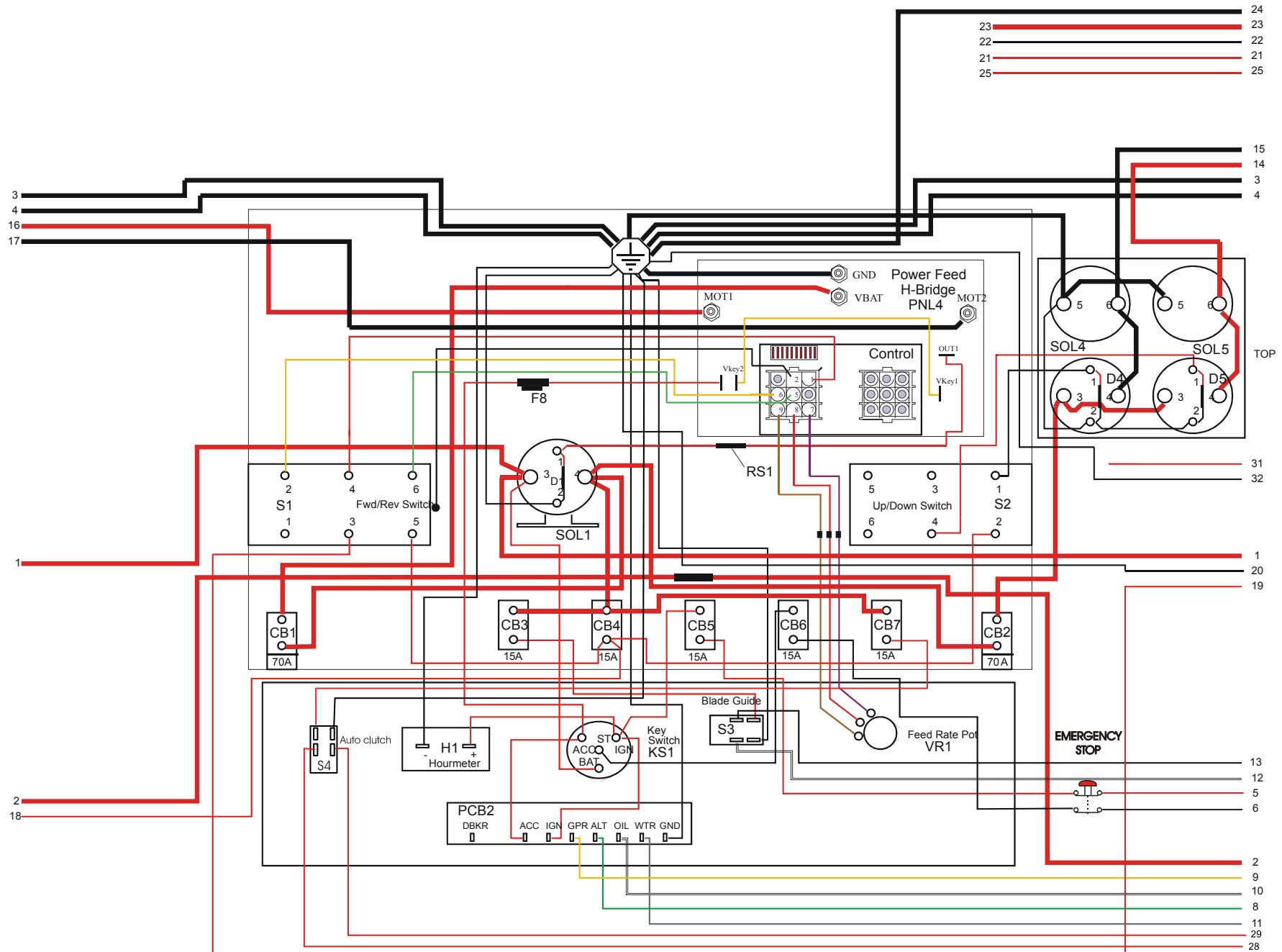

FIG. 4-2 D42 CONTROL BOX DIAGRAM).





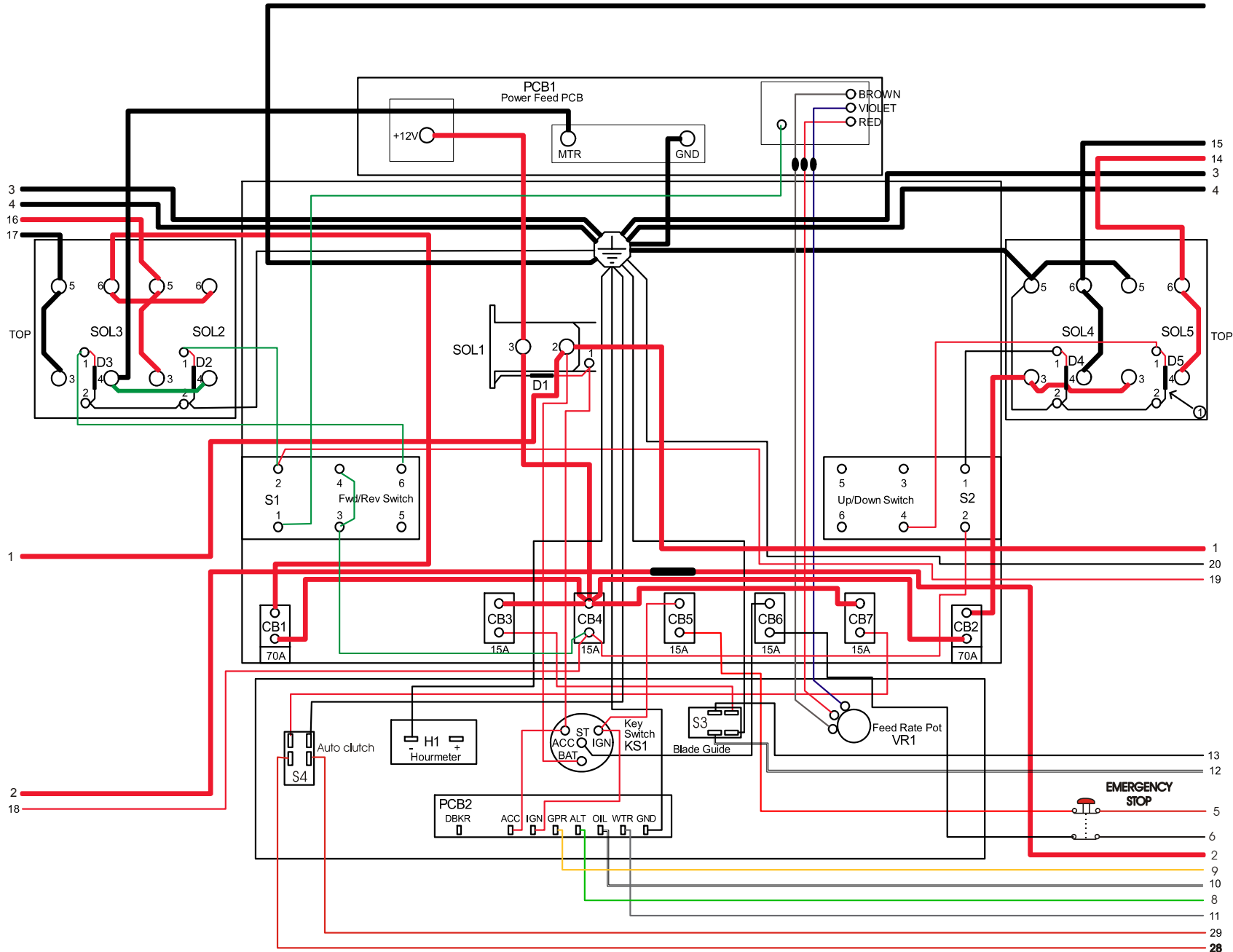

FIG. 4-4 D42 CONTROL BOX DIAGRAM (VARIABLE REVERSES MOVEMENT SPEED).

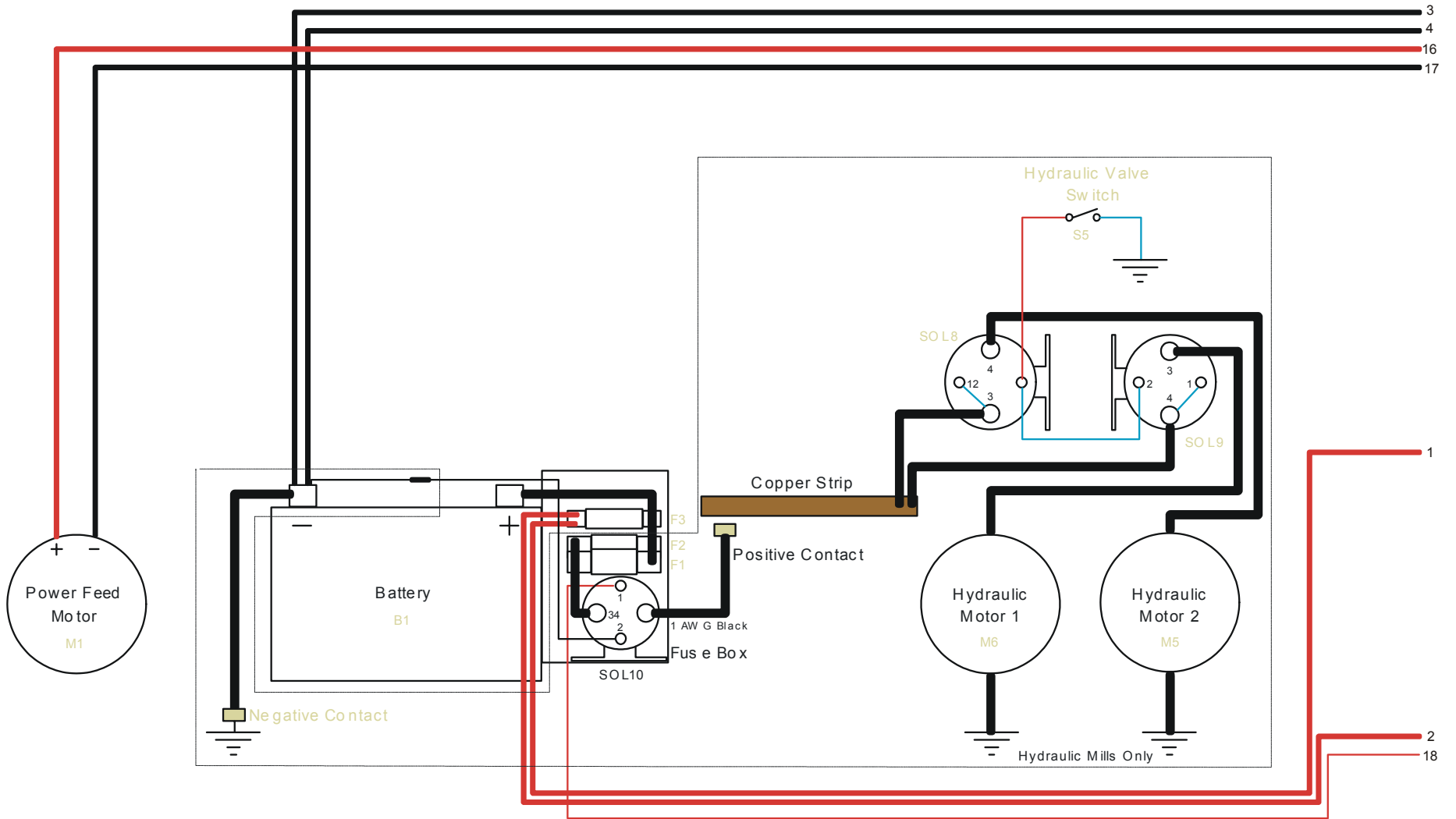

FIG. 4-5 D42 HYDRAULIC DIAGRAM.

Component List				
Item	Mfg. Part No.	Mfg.	Wood-Mizer Part No.	Description
A1	023 73 0	Wood-Mizer	023 73 0	Alternator, 14 0 Amp
B1	12 31 PMF	Deka	015475	Battery, 12 Volt ( <a href="#">See Battery Specifications</a> )
CB1	70-164 8-009	Mech. Prod.	015 52 7	Breaker, 70 Amp Manual Reset Panel Mount, Power Feed
CB2	70-164 8-009	Mech. Prod.	015527	Breaker, 70 Amp Manual Reset Panel Mount, Up/Down
CB3	CH304 07 -15	Cole-Hersee	E204 30	Breaker, 15 Amp Manual Reset, Blade Guide
CB4	CH304 07 -15	Cole-Hersee	E204 30	Breaker, 15 Amp Manual Reset, Accessory
CB5	CH304 07 -15	Cole-Hersee	E204 30	Breaker, 15 Amp Manual Reset, Ignition
CB6	CH304 07 -15	Cole-Hersee	E204 30	Breaker, 15 Amp Manual Reset, Start
CB7	CH304 07 -15	Cole-Hersee	E204 30	Breaker, 15 Amp Manual Reset, Board Return
CB1 0	024 45 3	Wood-Mizer	024 45 3	Breaker Assy, Water Temp Max Circuit
D1 - D5	087496	Wood-Mizer	087496	Diode Assembly, Solenoid Coil Chassis
D7	024 12 3	Wood-Mizer	024 12 3	Diode Assembly, Inductive Kick Protection (Setworks Only)
F1, F2 <sup>1</sup>	RL-225	Gould	P1155 0	Fuse Link, 225 Amp, 250 Volt For Hydraulic + 12 Volt Circuit
F3	RL-150	Gould	023361	Fuse Link, 150A 250V For Main + 12 Volt Starter, Alternator
F4	N/A	N/A	02 45 97	Fuse Link, 50 Amp Kubota Glow Plug
GP 1-GP 4	16851- 65510	Kubota	092277	Glow Plug
H1	T14BH517BC9	ENM Corp.	015 40 1	Hour Meter, 12 Volt, Low Power T14 Series
KS 1	121801	General	P0 4350	Key Switch, 4-position (Accessory, Off, Ignition, Start)
M1	10 86 77 .00	Leeson	024 16 9	Motor, 3/4HP 12VDC TEFC Power Feed w/o Base
M2	10 86 78 .00	Leeson	015 17 4	Motor, 3/4HP 12VDC TEFC Up/Down w/Base
M3	P096 98 -1	Klauber	A10 36 5	Motor, 12 Volt Blade Guide Arm 53:1 Gear
M4	P096 98 -1	Klauber	A10 36 5	Motor, 12 Volt Board Return 53:1 Gear
M5, M6 <sup>1</sup>	81 11	Monarch	P09955	Motor, 12 Volt Hydraulic Pump
PCB1	051667	Wood-Mizer	051667	Circuit Board, Control Box Power Feed
PCB2	089694	Wood-Mizer	089694	Board, LED Circuit (Diesel)
R1	1238 537	Bosch	092277	Relay, Glow Plug Timer
S1	26 01-AF 2-S 11	Square D	E20438	Drum Switch, Power Feed Fwd/Reverse Motor
S2	26 01 -AF2-S12	Square D	E20 44 0	Drum Switch, Up/Down Motor
S3	34 -591Q	Pollak	024 20 0	Toggle Switch, Blade Guide In/Out Motor
S4	34 -591Q	Pollak	02 42 00	Toggle Switch, Board Return Motor
S5 <sup>1</sup>	024 19 8	Wood-Mizer	024 19 8	Switch, Hydraulic Pump Levers
S6	15841- 39010	Kubota	028 54 7	Switch, Oil Pressure Sensor
S7	TM9A 230RQCG	Kubota	028 51 0	Switch, Water Temp Sensor
SO L1	015470	Stancor	015470	Solenoid 200 A 12V SPST
SO L4 -SO L5	58 6-911	Stancor	01 54 17	Solenoid, 200 A 12V DPST
SO L7	17454- 60010	Kubota	028 52 3	Solenoid, Fuel
SO L8, SO L9, SO L10 <sup>1</sup>	586- 902	Stancor	015470	Solenoid, 200 A 12V SPST Hydraulic Pump Motor
V1	G51190 14 5	Parker	016 28 0	Valve, Waterlube Solenoid
VR 1	E20519	Wood-Mizer	E20519	Potentiometer, Variable Resistance Power Feed