

D42 Engine

Safety, Operation, Maintenance & Parts Manual

LT70S DH	rev.A1.00-B2.00
LT70M DH	rev.A1.00-B2.00
LT70L DH	rev.A1.00-A5.00



Safety is our #1 concern! Read and understand all safety information and instructions before operating, setting up or maintaining this machine.

February 1998

Form #916

Table of Contents

Section-Page

SECTION 1 OPERATION

1-1

1.1 Starting The Engine1-1

SECTION 2 MAINTENANCE

2-1

2.1 Safety2-1

2.2 Cooling System2-2

2.3 Fuel Filter2-3

2.4 Battery2-5

2.5 Alternator Belt2-6

2.6 Radiator Fan Belt Adjustment2-7

2.7 RPM Adjustments2-8

2.8 Centrifugal Clutches Maintenance2-11

SECTION 3 REPLACEMENT PARTS

3-1

3.1 Fuel Tank3-1

3.2 Engine Mount Assembly3-2

3.3 Engine Assembly3-3

3.4 Primary Fuel Filter3-5

3.5 Acceleration/Brake Assembly3-6

3.6 Muffler Assembly3-9

3.7 Radiator Assembly3-10

3.8 Alternator Assembly3-11

3.9 Engine Guards3-13

SECTION 4 ELECTRICAL WIRING DIAGRAMS, D42

4-1

ABOUT THIS MANUAL

This manual is provided as a supplement to the equipment manufacturer's manuals. This manual provides information specific to the use of this equipment on the Wood-Mizer® sawmill. Refer to the sawmill operator's manual and manufacturer's manual before attempting to operate this equipment.



IMPORTANT! Read the sawmill operator's manual and engine manufacturer's manual for instructions and safety precautions before operating this equipment.

The information and instructions given in this manual do not amend or extend the limited warranties for the equipment given at the time of purchase.

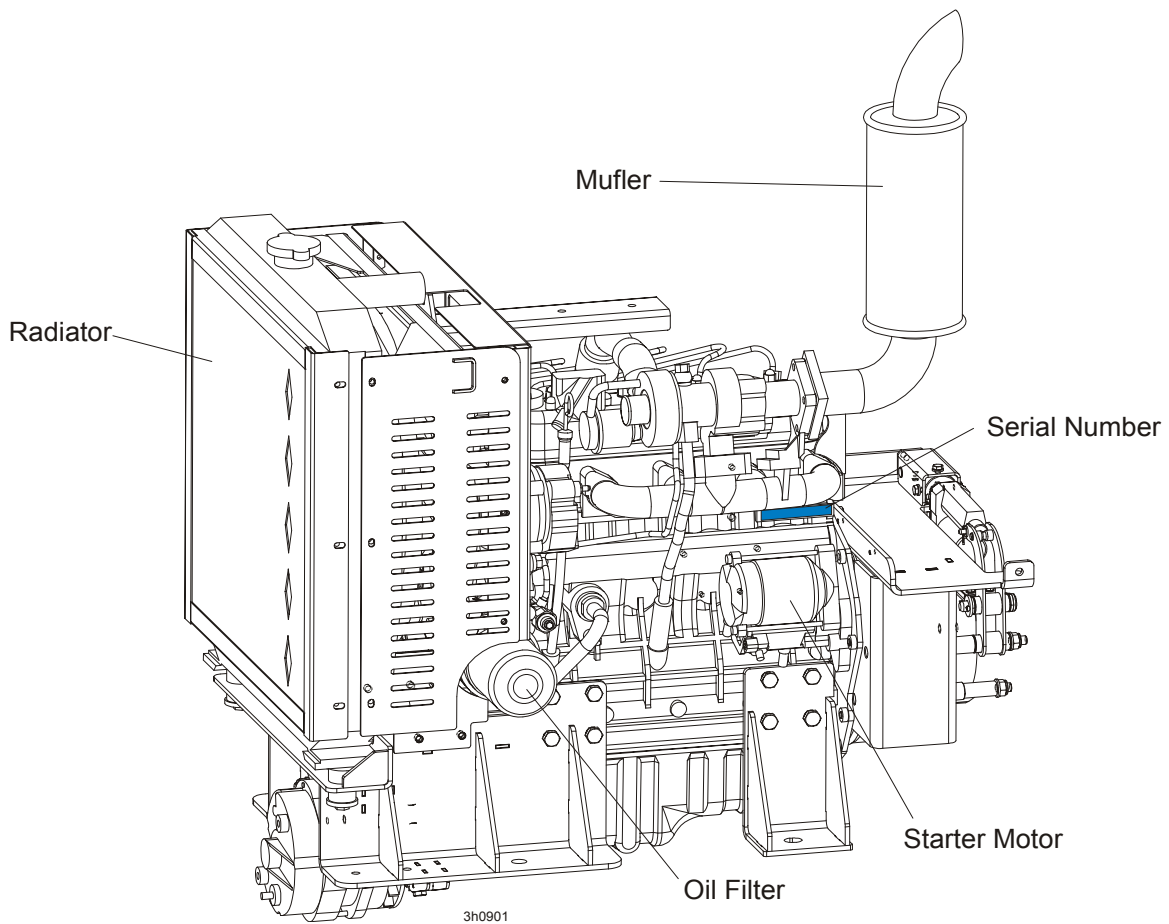

ENGINE COMPONENTS

SECTION 1 OPERATION

1.1 Starting The Engine

Control Lights

See Figure 1-1. The following indicator lights are located on the sawmill control panel.

 *Alternator Charge Indicator:* Lights up if the alternator is not charging the battery.



 *Engine Temperature Indicator:* Lights up if the engine is overheating. A circuit breaker assembly in the engine harness will shut the engine off if the engine overheats. Turn the key switch off and allow the engine to cool for a period of time before restarting. If the overheating condition persists, stop operating the engine until the condition is corrected. The engine will automatically switch to low idle if an overheating condition occurs.



 *Key Switch Indicator:* Lights up when the key is in either the on or accessory (#1 or #3) position.



 *Oil Indicator:* Lights up if the oil pressure is too low.



 *Glow Plug Indicator:* Lights up after the key has been turned to the on (#1) position.

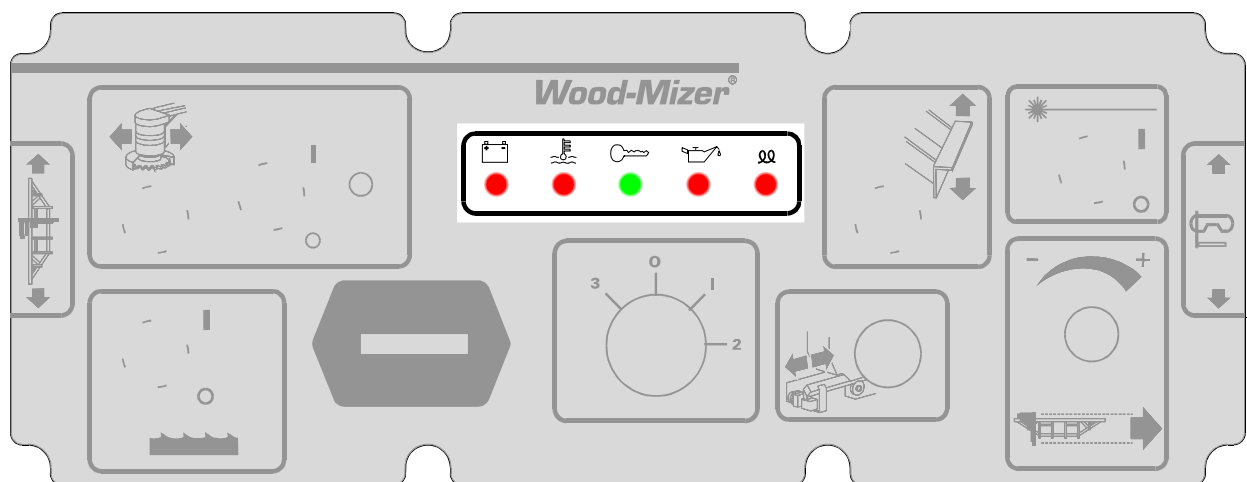

FIG. 1-1

Engine Start



DANGER! Always be sure the blade is disengaged and all persons are out of the path of the blade before starting the engine. Failure to do so will result in serious injury.

DANGER! Operate your engine/machine only in well ventilated areas. The exhaust gases of your engine can cause nausea, delirium and potentially death unless adequate ventilation is present.

DANGER! Never operate an engine with a fuel or oil leak. The leaking fuel or oil could potentially come in contact with hot surfaces and ignite into flames.



WARNING! Be sure the power feed switch is in the neutral position before turning the key switch to the on (#1) or accessory (#3) position. This prevents accidental carriage movement which may cause serious injury or death.

WARNING! Do not operate engine without proper and operational spark arrester/muffler. Sparks emitted from the engine exhaust could ignite surrounding materials, causing serious injury or death.



CAUTION! Do not crank starter for more than 7 seconds at one time during starting attempts. Damage to the engine may result.

CAUTION! Let engine idle for 2 minutes before applying load to prevent engine damage.

1. See the engine manufacturer's manual for lubricating oil recommendations for specific temperature ranges.
2. Use the best quality diesel fuel for below freezing starting.
3. Turn the key switch on the control panel to the on (#1) position.
4. Wait until the glow plug indicator goes out.
5. Turn the key switch to the start (#2) position and release.

1 Operation

Starting The Engine

Engine Shutoff



CAUTION! A minimum 2 minute idle time is recommended to allow the battery charge to recover before the engine is shut off.

Turn the key switch to the off (#0) position.

SECTION 2 MAINTENANCE

Refer to the manufacturer's manual for maintenance intervals and procedures unless otherwise instructed in this manual. Follow the manufacturer's recommendations for dusty conditions.



IMPORTANT! This manual only provides information about additional procedures or procedures to be performed at different time intervals than found in the manufacturer's manuals. Refer to the manufacturer's manual for complete maintenance instructions.

2.1 Safety

Use caution when performing maintenance or service to the engine.



DANGER! Always be aware of and take proper protective measures against rotating shafts, pulleys, fans, etc. Always stay a safe distance from rotating members and make sure that loose clothing or long hair does not engage rotating members resulting in possible injury.

DANGER! Engine components can become very hot during operation. Avoid contact with any part of a hot engine. The exhaust components of your engine are especially hot during and following operation. Contact with hot engine components can cause serious burns. Therefore, never touch or perform service functions on a hot engine. Allow the engine to cool sufficiently before beginning any service function.



WARNING! Remove the blade before performing any engine service. Failure to do so may result in serious injury.

WARNING! Always wear proper and necessary safety equipment when performing service functions. Proper safety equipment includes eye protection, breathing protection, hand protection and foot protection.



This symbol identifies the interval (hours of operation) at which each maintenance procedure should be performed. "AR" signifies maintenance procedures which should be performed as required.

2.2 Cooling System



Clean the radiator fins every 8 hours of operation. Spray the radiator with water from a hose or compressed air to clean sawdust from the radiator fins. Do not use a pressure sprayer.



CAUTION! Failure to keep the radiator fins clear of sawdust and/or dirt may cause the engine to overheat resulting in damage to the engine.

2.3 Fuel Filter



See Figure 2-1. Replace the primary fuel filter and prefilter cartridge every 200 hours. After replacing any of the two filter cartridges, loosen the air bleed screw on the main filter and turn the key switch on the control panel to #1 position and wait until fuel begins to flow from the valve and is free of air bubbles. Turn the key to #0 position. Tighten the bleed screw.

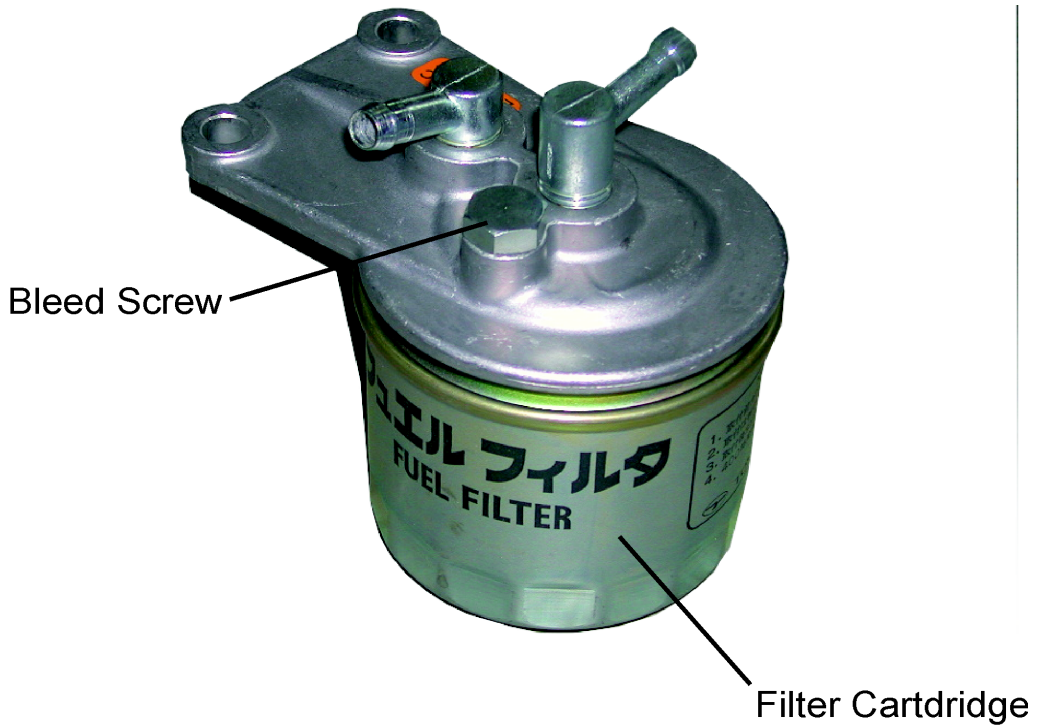

FIG. 2-1

2 Maintenance

Fuel Filter

See **Figure 2-2**. Inspect the water separator bowl on the prefilter periodically and drain the bowl as required by turning the drain cap counterclockwise as viewed from the bottom.

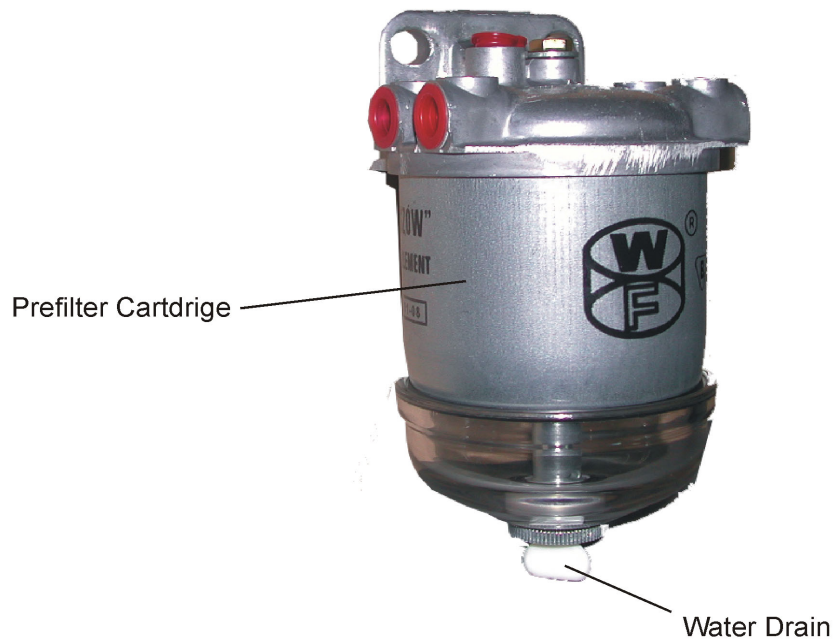

FIG. 2-2

2.4 Battery



Check the battery electrolyte level every 50 hours of operation. See manufacturer's manual for instructions.



DANGER! Batteries expel explosive gases. Keep sparks, flames, burning cigarettes, or other ignition sources away at all times. Always wear safety goggles and a face shield when working near batteries. Failure to do so will cause serious injury.¹



WARNING! Battery posts, terminals and related accessories contain lead and lead compounds, chemicals known to the State of California to cause cancer and reproductive harm. Wash hands after handling.

1. Battery Council International, copyright 1987

2.5 Alternator Belt



The belt tension should be checked after the first 100 hours of operation, when the battery is not charging properly or when the alternator belt is squealing. If the battery continues to not charge properly or the belt continues to squeal after the initial belt adjustment, replace the belt.

1. Turn the key switch to OFF (#0) and remove the key.
2. Remove the alternator cover.

See Figure 2-3.

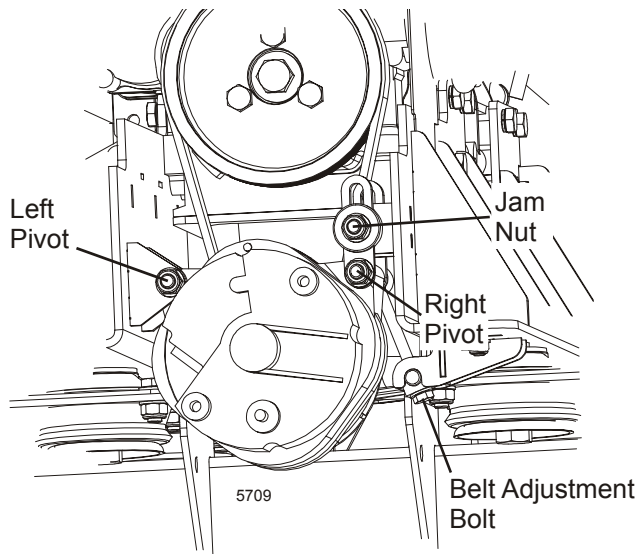

FIG. 2-3

3. Loosen the left pivot, right pivot and jam nut.
4. Turn the belt tension adjustment bolt clockwise to tighten the belt, counterclockwise to loosen the belt. Adjust the bolt until the proper belt tension is achieved.



CAUTION! Do not overtighten the alternator belt. Damage to the alternator will occur.

5. After the alternator belt has been tensioned, tighten the jam nut. Tighten the left and right pivots and replace the belt covers.

2.6 Radiator Fan Belt Adjustment

AR The fan belt tension should be checked after the first 100 hours of operation, when the engine is overheating or when the fan belt is squealing. If the engine continues overheating or the belt continues to squeal after the initial belt adjustment, replace the belt.

1. Turn the key switch to OFF (#0) and remove the key.
2. Remove the radiator covers.
3. Loosen the jam nut (shown below).
4. Tension the fan belt properly by hand.
5. Tighten the jam nut and replace the radiator covers.

See Figure 2-4.

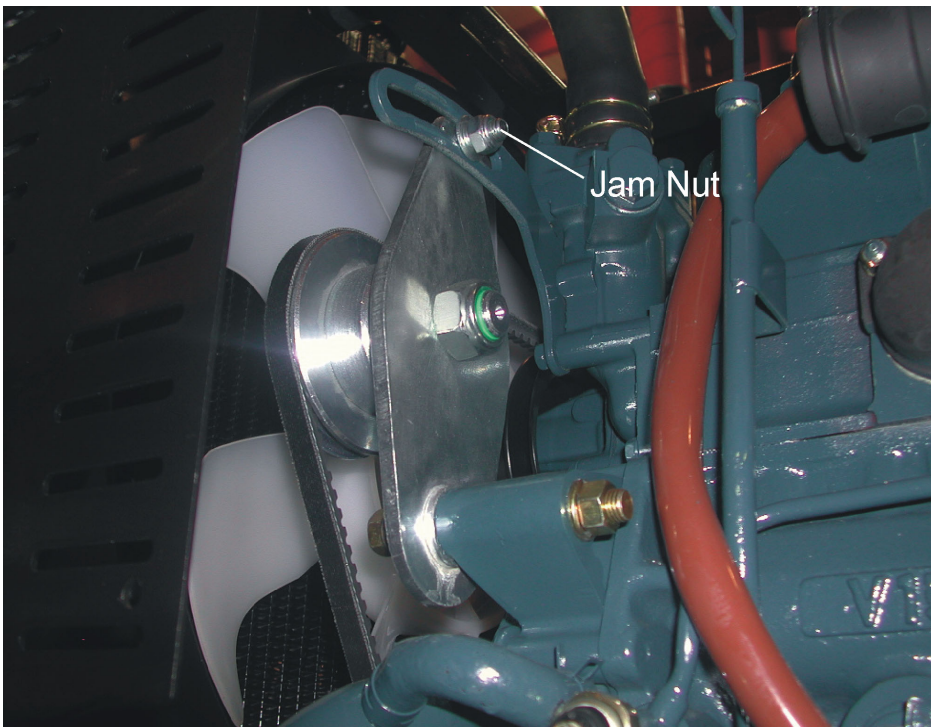

FIG. 2-4

2.7 RPM Adjustments



WARNING! Remove the blade before performing any engine service. Failure to do so may result in serious injury.



CAUTION! The engine RPM should be adjusted when the engine is warmed up to its working temperature.



Check the RPM with a tachometer after the first 20 hours of operation and every 200 hours thereafter. High-end RPM should be 3000 RPM and low-end RPM should be 1150 RPM.

Before checking the RPM, make sure belt and brake strap tensions are correct (See Saw-mill Maintenance). Also check oil, fuel, and coolant levels.

To adjust brake strap, set the adjustment bolt so that the braking time is about 5-7 seconds.

Make sure the throttle cable does not affect the engine RPM when the blade switch is disengaged. Make sure the cable is not bent or kinked.

1. When the blade switch is disengaged, the throttle cable should be taut but the spring not extended. When the blade switch is engaged, the throttle spring should extend 1/8" to 1/4".



CAUTION! Do not extend the throttle spring over 1/4". Excessive tension may cause the throttle cable to fail prematurely.

See Figure 2-5. Use the adjustments shown below to adjust the engine RPM (3000[+0,

-50] high-end, 1150[±50] idle).

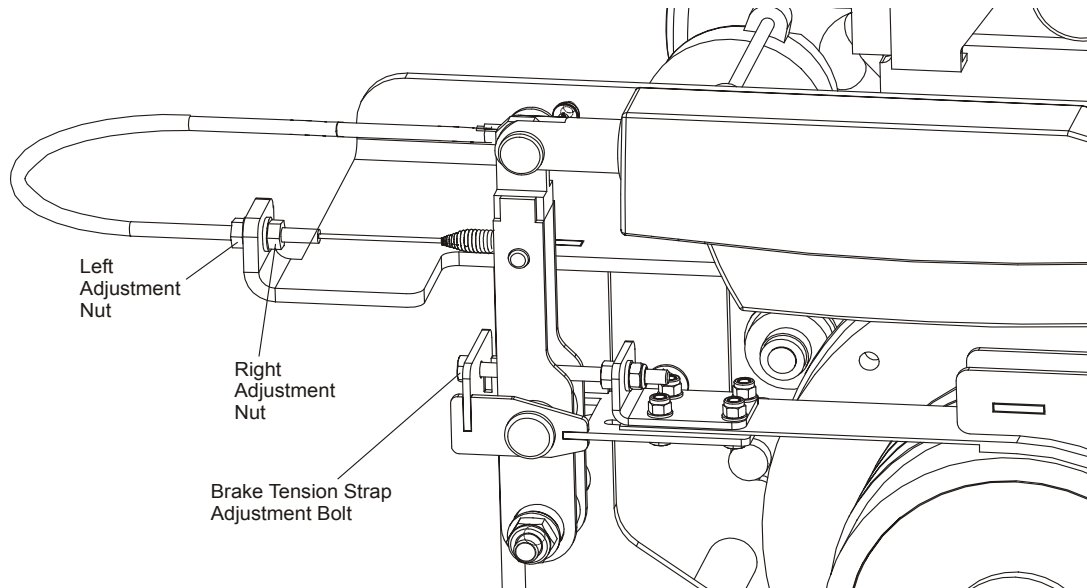

FIG. 2-5



CAUTION! Do not adjust the high-end RPM above 3200.
Doing so may cause damage to the engine.

2. After the RPM settings are made, shut the engine off. Tighten the throttle cable by engaging the blade switch. Check the throttle cable at the upper cable mounting bracket. The cable should be centered in the cable housing. If necessary, loosen the upper bracket mounting bolts and adjust the bracket so the cable housing is centered around the cable. Retighten the upper cable bracket mounting bolts.

See Figure 2-6.

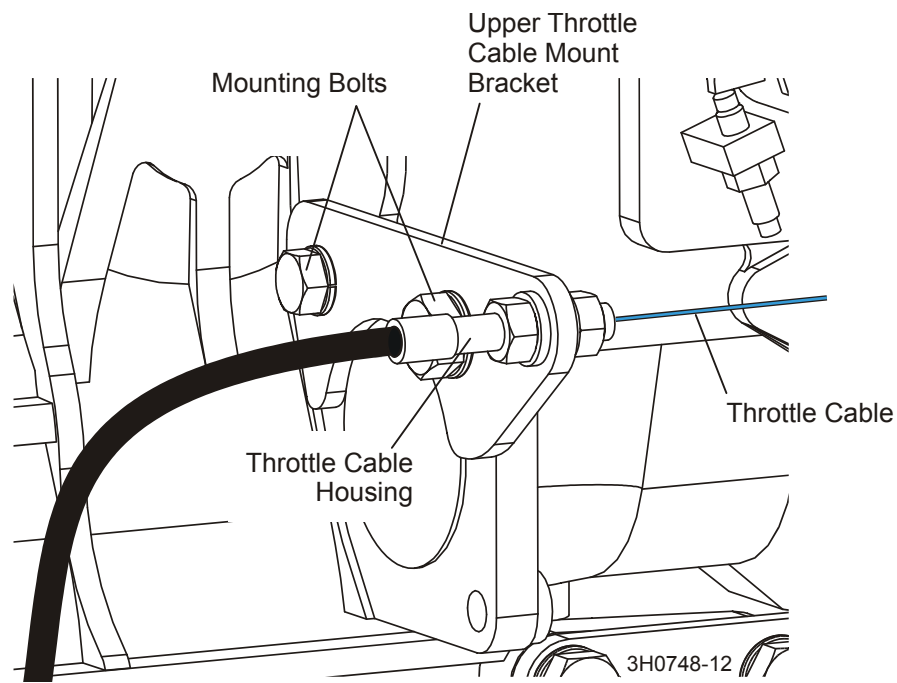

FIG. 2-6



CAUTION! Failure to properly center the throttle cable in the cable housing may result in premature cable wear.

2.8 Centrifugal Clutches Maintenance

Always shut off the engine and allow the sawmill to come to a complete stop before performing any engine service.

Before replacing the extension springs clean the clutch with compressed air.

500 ▶ The extension springs should be replaced every 500h of operation. Check the clutch linings and replace them if they are worn to a thickness smaller than 1.5 mm.

Idling r.p.m., brake strap tension and clutch braking time should be checked after every extension springs replacement.

See Picture 2-7.

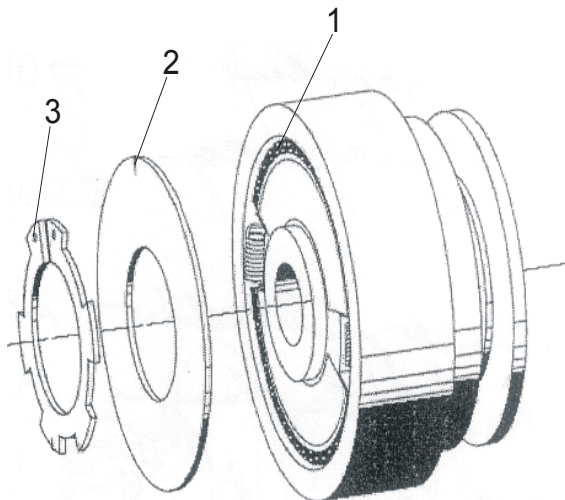

PIC. 2-7

Clutch linings and extension springs replacement:

1. Remove retaining ring (Fig.2-7 pos.3) and the cover plate (Fig.2-7 pos.2).
2. Pull out the linings and flyweights (Fig.2-7 pos.1).
3. Remove worn linings from the flyweights.
4. Fit new linings and extension springs. The hook opening should be turned outside!
5. Install the cover plate and secure with retaining ring.

2

Maintenance

Centrifugal Clutches Maintenance

The Seeger-L-circlip is slightly conical in shape and applies a degree of pressure on the plate. It must be fitted with the radial fingers of the circlip pressing towards the cover ensuring at the same time that the circlip is fully seated in the hub groove.



CAUTION! Clutches must be fully assembled with the drum in position and cover plated fastened before the driving machine is started.

SECTION 3 REPLACEMENT PARTS

3.1 Fuel Tank

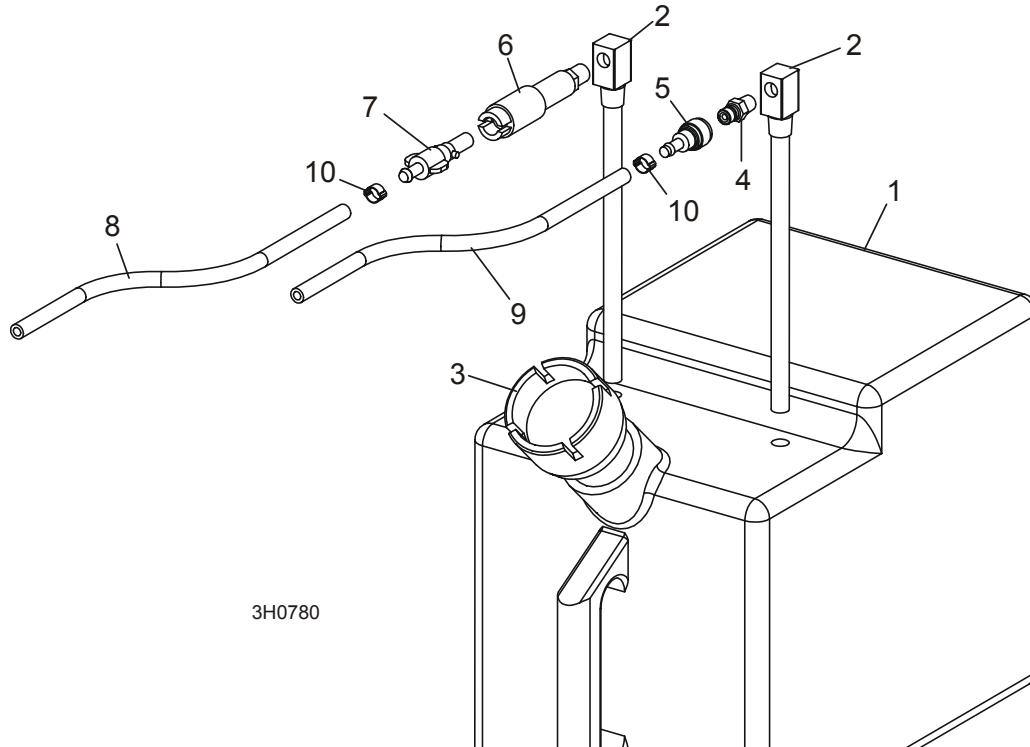

3H0780

REF	DESCRIPTION (◆ Indicates Parts Available In Assemblies Only)	PART #	QTY.	
	TANK ASSEMBLY, 5 GALLON GREEN DIESEL	A12132	1	
1	Tank, 5 Gallon Green Fuel	P12166	1	◆
2	Pickup, 9" Fuel	P12172	2	
3	Cap, 3/5 Gallon Fuel Tank	P09683	1	
4	Fitting, 1/4" NPT Male Quick Disconnect	015583	1	
5	Fitting, Female Quick Disconnect Barb	015582	1	
6	Fitting, 1/4" NPT Plastic Female Disconnect	P12175	1	
7	Fitting, 1/4" Barb Plastic Male Disconnect	P12176	1	
8	HOSE, 1/4" ID FUEL	P642	7.17 Ft	
9	HOSE, 5/16" ID FUEL	016338	9 Ft.	
10	CLAMP, 7/32 - 1/2 HOSE	P649	6	
	ADDITIVE, DIESEL FUEL 16OZ BOTTLE	004878 ¹	1	

¹ Stanadyne Performance Formula helps eliminate contaminants and water in fuel, prevents gelling in cold weather, and improves lubrication of fuel system parts. 16 oz. bottle treats 60 gallons of diesel fuel.

3.2 Engine Mount Assembly

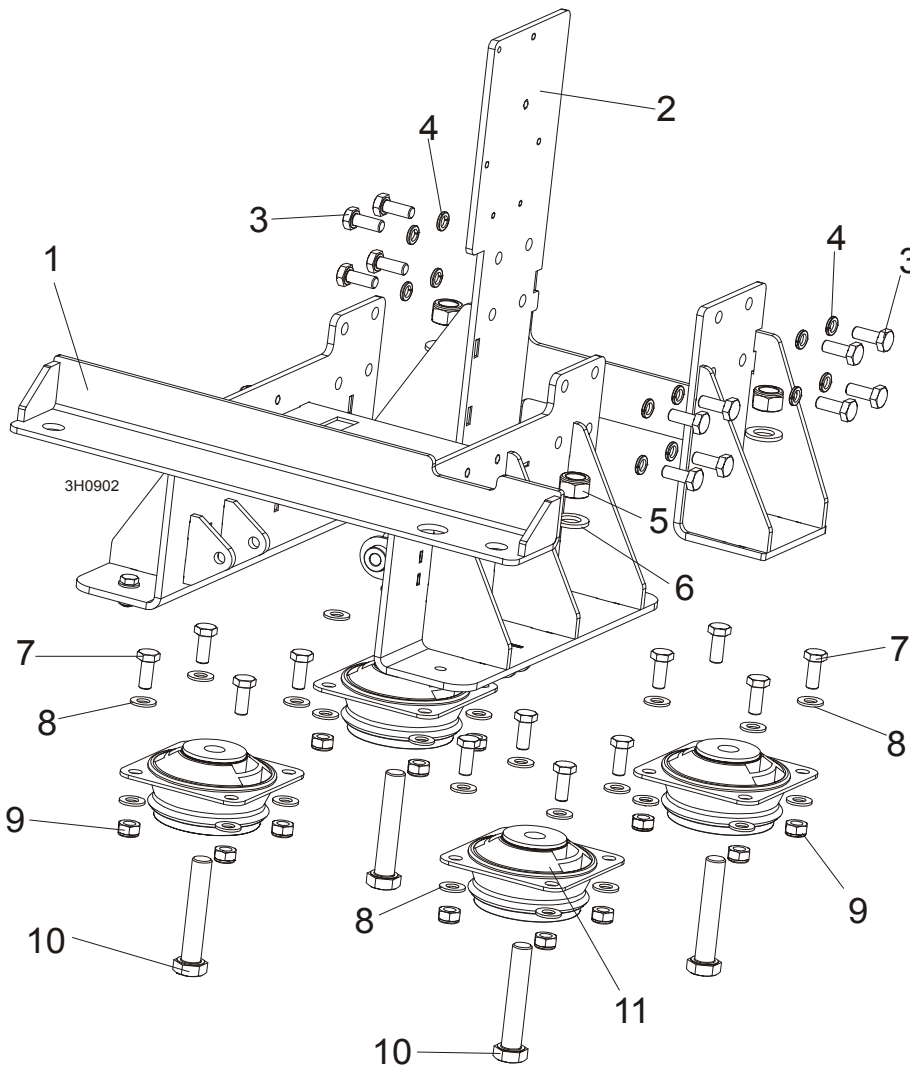

REF	DESCRIPTION (◆ Indicates Parts Available In Assemblies Only)	PART #	QTY.	
1	MOUNT WELDMENT, REAR D42 ENGINE	089468-1	1	◆
2	MOUNT WELDMENT, FRONT D42 ENGINE	089459-1	1	◆
3	BOLT, M10X1.25X25-8.8-A HEX HEAD FULL THREAD ZINC	F81003-29	16	
4	WASHER, 10.2 ZINC SPLIT	F81055-2	16	
5	NUT, M16-8 HEX NYLON ZINC LOCK	F81036-2	4	
6	WASHER, 17 ZINC FLAT	F81058-1	4	
7	BOLT, M10X25 8.8 HEX HEAD FULL THREAD	F81003-31	16	
8	WASHER, 10.5 ZINC FLAT	F81055-1	32	
9	NUT, M10-8-B HEX NYLON ZINC LOCK	F81033-1	16	
10	BOLT, M16X90-8.8 HEX HEAD ZINC	F81006-17	4	
11	SHOCK ABSORBER MEGI-LAGER 742 062 S1 STEEL, RUBBER	088570	4	

3.3 Engine Assembly

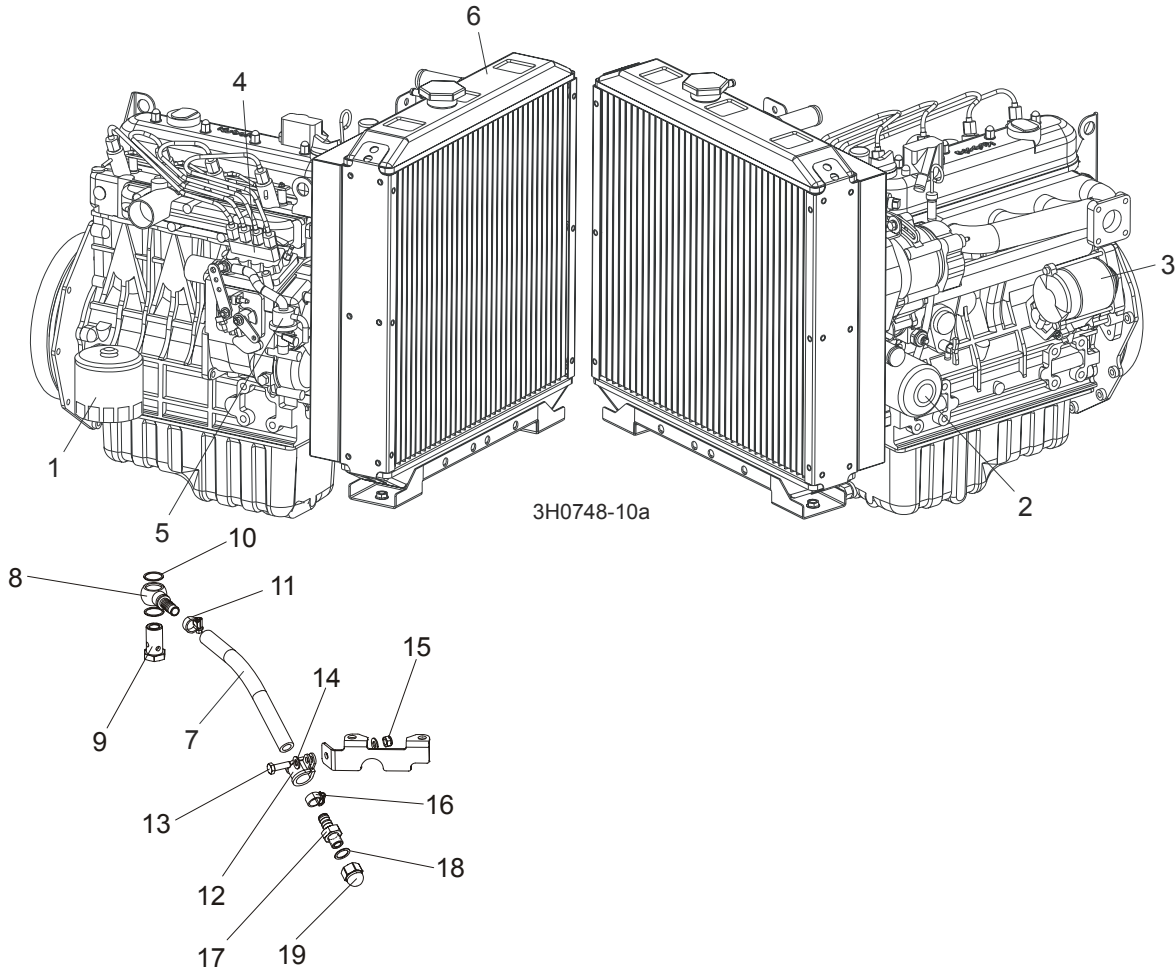

REF	DESCRIPTION (◆ Indicates Parts Available In Assemblies Only)	PART #	QTY.
	ENGINE, KUBOTA 1505TE	088022	1
	Belt, Kubota Fan #16282-97010	028514	1
	Filter, Kubota D42 Air B53/207(16617-11001)	088025	1
1	Filter, Kubota D42 Fuel, Complete	088024	1
	Filter, Kubota Fuel 16616-43001(D52/184)	028560	1
2	Filter, Kubota Oil #16271-32090	018050	1
	Gasket Kit, Kubota Lower #07916-29265	028519	1
	Gasket Kit, Kubota Upper #16285-99352	028572	1
	Gasket, Kubota Exhaust #15263-12370	028513	1
	Gasket, Kubota Fuel Injector #15841-53622	028516	1
	Gasket, Kubota Fuel Transfer Pump #16264-52140	028518	1
	Gasket, Kubota Head #16292-03310	028571	1
	Gasket, Kubota Muffler #15263-12371	028549	1

3 Replacement Parts

Engine Assembly

	Gasket, Kubota Oil Drain Plug #15451-96670	028543	1	
	Gasket, Kubota Stop Solenoid #16299-60150	028544	1	
	Gasket, Kubota Thermostat #15313-7320	028545	1	
	Gasket, Kubota Valve Cover #16241-14520	028524	1	
	Gasket, Kubota Water Pump #16259-73430	028526	1	
	Glow Plug, Kubota #16851-65510	028562	1	
	Injector, Kubota Fuel #16032-53000	028515	1	
3	Motor, Kubota Starter #37560-63010	028522	1	
4	Pump, Kubota Fuel Injector #16060-51010	028540	1	
5	Pump, Kubota Fuel Transfer #16285-52032	028517	1	
	Pump, Kubota Water #16241-73032	028525	1	
6	Radiator Parts (See Section 1.5)			
	Sending Unit, Kubota Heat Sensor #TM9A230RQCG	028510	1	
	Solenoid, Kubota Stop #17454-60010	028523	1	
	Switch, Kubota Oil Pressure #15841-39010	028547	1	
	Thermostat, Kubota #19434-73010	028546	1	
	HARNESS ASSEMBLY, KUBOTA DIESEL ENGINE	024594	1	
	Breaker Assembly, Water Temp Max Circuit	024453	1	
	Socket, Glow Plug Relay w/Fuse Holder	024554	1	
	Fuse Link, 50 Amp	024597	1	
	Relay, Glow Plug	088143	1	
	RELAY, 40A, 12V	021238	1	
	HOSE, D42 ENGINE OIL DRAIN	091774	1	
7	Hose, Oil Drain	091777	1	
8	End, BANJO M22x1.5x1/2 ZMB 600-22-08	091773	1	
9	Bolt, BANJO M22x1.5 ZMB 610-22/1.5	091772	1	
10	Washer, 22 Copper	F81061-5	2	
11	Clamp, 12-20mm Diameter Hose	F81080-3	1	
12	Ring, RSGU 1.20/20 Hose Bracket	F81087-2	1	
13	Bolt, M8x25-8.8-B Hex Head Full Thread Zinc	F81002-5	1	
14	Washer, 8.4 Flat Zinc	F81054-1	2	
15	Nut, M8-8-B Hex Nylon Zinc Lock	F81032-2	1	
16	Clamp, 12-20mm Diameter Hose	F81080-3	1	
17	End, Oil Drain Hose	091776	1	
18	Washer, 16 Copper	F81058-3	1	
19	Nut, M16x1.5 Hex Domed Cap Zinc	F81036-7	1	

3.4 Primary Fuel Filter

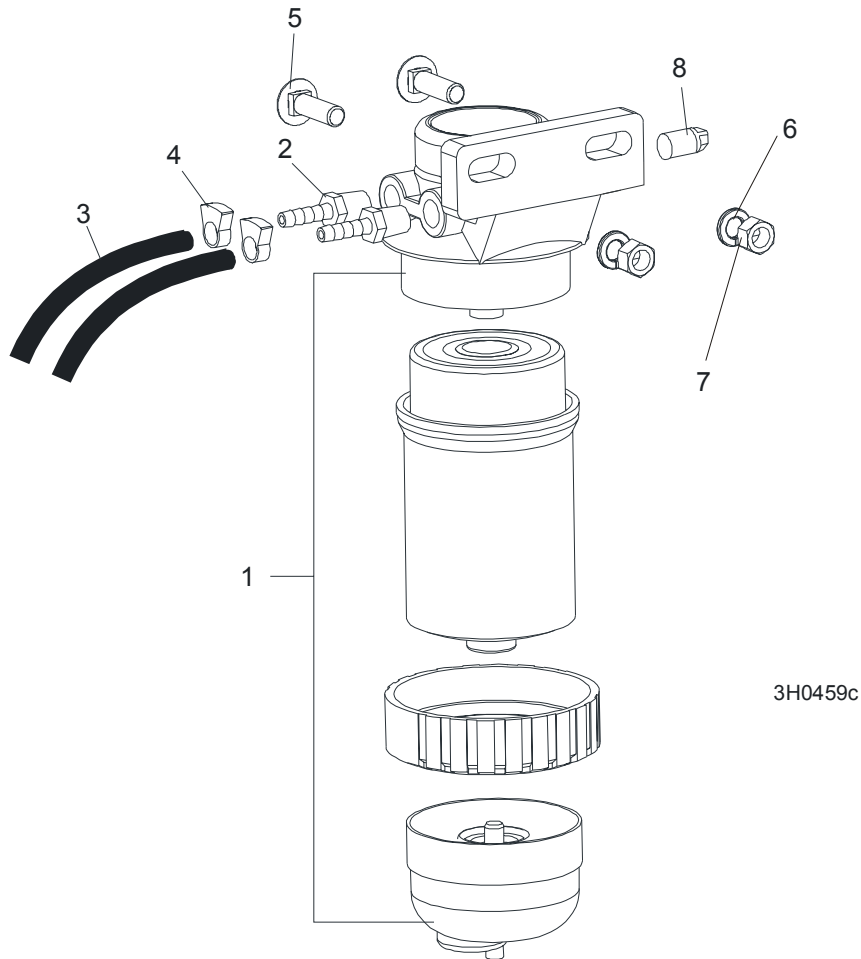

REF	DESCRIPTION (◆ Indicates Parts Available In Assemblies Only)	PART #	QTY.	
1	FILTER ASSEMBLY, STANDADYNE FUEL FPV-5,7 04WP40/3	088101	1	
2	FITTING, 8MM, FILTR FPV-5,7	088094	2	
3	HOSE, 5/16" ID FUEL	R80703-2	2m	
4	CLAMP, 11-17MM HOSE	F81080-3	2	
5	BOLT, 3/8-16 X 1 1/4" CARRIAGE HEAD	F05007-11	6	
6	WASHER, 3/8" SPLIT LOCK	F05011-4	6	
7	NUT, 3/8-16 HEX	F05010-1	6	
8	FITTING, 1/4" NPT PLUG	P05498	2	

3 Replacement Parts

Acceleration/Brake Assembly

3.5 Acceleration/Brake Assembly

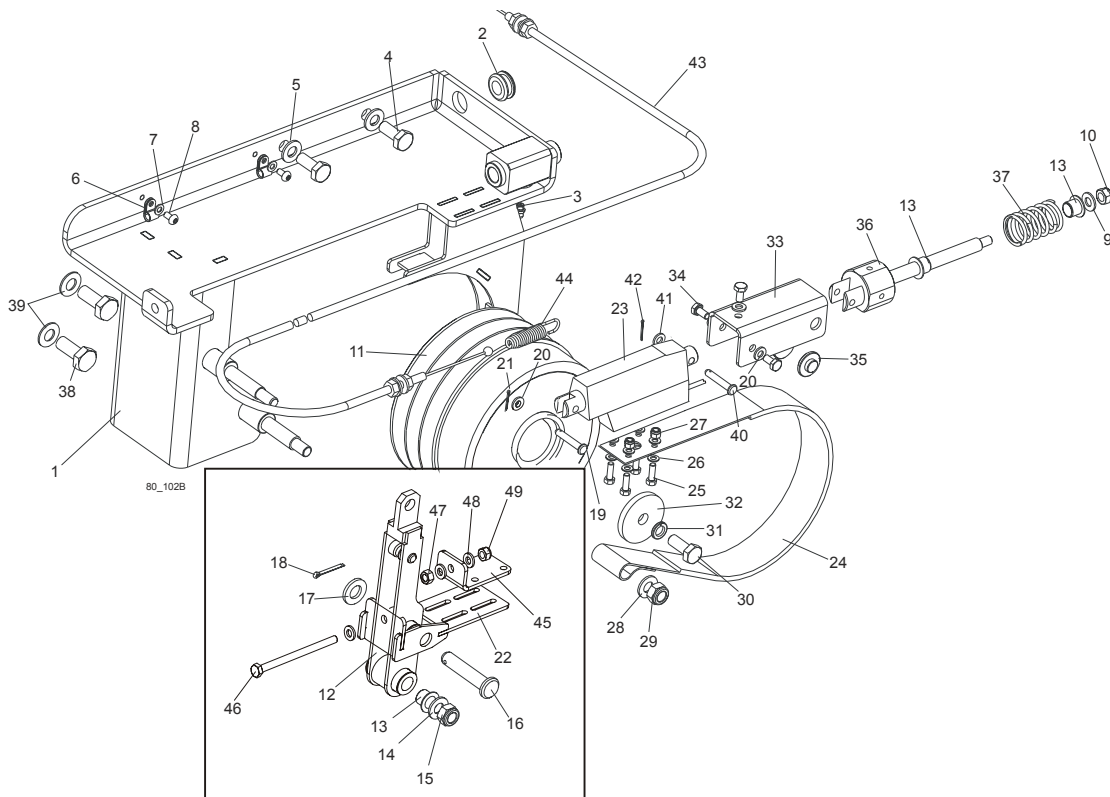

REF	DESCRIPTION (◆ Indicates Parts Available In Assemblies Only)	PART #	QTY.
	ACCELERATION/BRAKE ASSEMBLY, D42	091750	1
1	Bracket, Acceleration/Brake Assy, LA12	091343-1	1
2	Grommet, 20/13 Rubber	086188	1
3	Fitting, M6 Straight Grease	086280	1
4	Bolt, M10x1.25x25-8.8-A Hex Head Full Thread Zinc	F81003-29	2
5	Washer, 10.5 Zinc Flat	F81055-1	2
6	Clamp, EE63 Throttle Cable	F81080-4	2
7	Washer, 5.3 Zinc Flat	F81052-1	2
8	Screw, H M5x10 8.8 Cross Recessed Pan Head Zinc	F81000-13	2
9	Washer, 8.4 Zinc Flat	F81054-1	1
10	Nut, M8-8-B Hex Nylon Zinc Lock	F81032-2	1
11	Clutch, Type 140-1139 (RADIUS-RADPOL) Centrifugal	089467	1
	Clutch Repair Kit, 140-1139 type	084109-1	
	Friction Linings Kit, 140-1139 type	084109	2
	Spring, Centrifugal Clutch	091649	4
	Cover, Type 140-1139 Clutch	084109-2	1
	Ring, AL.60 (440-5049) Retaining	084109-3	1

12	Lever, Strap Brake	091339-1	1	
13	Bushing, XFM-1214-12 Flanged	088934	3	
14	Washer, 10.5 Zinc Flat	F81055-1	1	
15	Nut, M10-8-B Hex Nylon Zinc Lock	F81033-1	1	
16	Pin, B 12X60/53 Clevis w/Head Zinc	F81049-3	1	
17	Washer, 13 Zinc Flat	F81056-1	1	
18	Pin, 3.2x25 Zinc Cotter	F81043-4	1	
19	Pin, B-10x32x3,2x26-St-A2 Clevis W/Head Zinc	F81047-1	1	
20	Washer, 10.5 Zinc Flat	F81055-1	4	
21	Pin, 1.6x16 Zinc Cotter	F81040-1	1	
22	Plate, Brake Strap Mount	096273-1	1	
23	Actuator, LA121000-20401210 Linear	091309	1	
24	Strap, K140ER Clutch/Brake	088935	1	
25	Bolt, M5x16 -8.8 Hex Head Full Thread Zinc	F81000-20	4	
26	Washer, 5.3 Zinc Flat	F81052-1	8	
27	Nut, M5-8 DIN 985 Zinc	F81030-2	4	
28	Washer, 10.5 Zinc Flat	F81055-1	1	
29	Nut, M10-8-B Hex Nylon Zinc Lock	F81033-1	1	
30	Bolt, M10x25 8.8 Hex Head Full Thread	F81003-31	1	
31	Washer, 10.2 Zinc Split	F81055-2	1	
32	Washer, Zinc Special	088956-1	1	
33	Guard, Acceleration/Brake Spring	089435-1	1	
34	Bolt, M6x12-8.8 Hex Head Full Thread Zinc	F81001-7	3	
35	Pad, Linear Actuator Slide	089436	2	
36	Block, Actuator Mount w/Shaft Zinc LA12	091342-1	1	
37	Spring, 60x23x3 Zinc	088992	1	
38	Bolt, M8x20-8.8-B Hex Head Full Thread Zinc	F81002-4	2	
39	Washer, 8.4 Flat Zinc	F81054-1	2	
40	Pin, B-10x32x3,2x26-St-A2 Clevis w/Head Zinc	F81047-1	1	
41	Washer, 10.5 Flat Zinc	F81055-1	1	
42	Pin, 1.6x16 Zinc Cotter	F81043-4	1	
43	CABLE, THROTTLE	089450	1	
44	SPRING, 40X9X2.2 SPECIAL	089451	1	
45	ANGLE, ADJUSTMENT PAINTED	096277-1	1	
46	BOLT, M6x80 5.8 HEX HEAD FULL THREAD ZINC	F81001-61	1	
47	NUT, M6-8 HEX ZINC	F81031-1	1	
48	NUT, M6-8-B HEX NYLON ZINC LOCK	F81031-2	1	
49	WASHER, 6.4 FLAT ZINC	F81053-1	3	
	RETROFIT KIT, LINEAR ACTUATOR "LINAK".D42-LT70	094501 ¹	1	
	RETROFIT KIT, BRAKE STRAP ADJUSTMENT	096566 ²	1	

¹ The kit was created for the LT70 Series sawmills with D42 engines mounted before 1 January 2005. The kit includes D42 acceleration/brake assembly (Part No. 091750) and new engine side guards.

3 Replacement Parts

Acceleration/Brake Assembly

² The kit includes brake strap mount plate (Part No. 096273-1) and adjustment angle (Part No. 096277-1) along with mounting hardware (02/2006).

3.6 Muffler Assembly

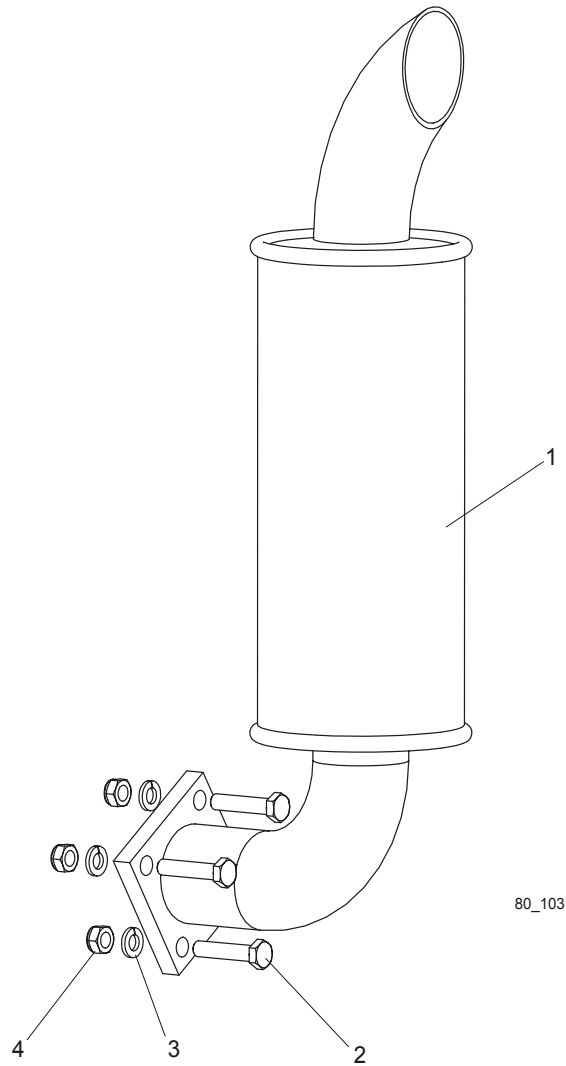

REF	DESCRIPTION (◆ Indicates Parts Available In Assemblies Only)	PART #	QTY.	
1	MUFFLER, KUBOTA ENGINE	088100	1	
2	BOLT, M8X40-8.8 HEX HEAD FULL THREAD ZINC	F81002-15	4	
3	WASHER, 8.2 ZINC SPLIT LOCK	F81054-4	4	
4	NUT, M8 HEX WELD	F81032-3	4	

3 Replacement Parts

Radiator Assembly

3.7 Radiator Assembly

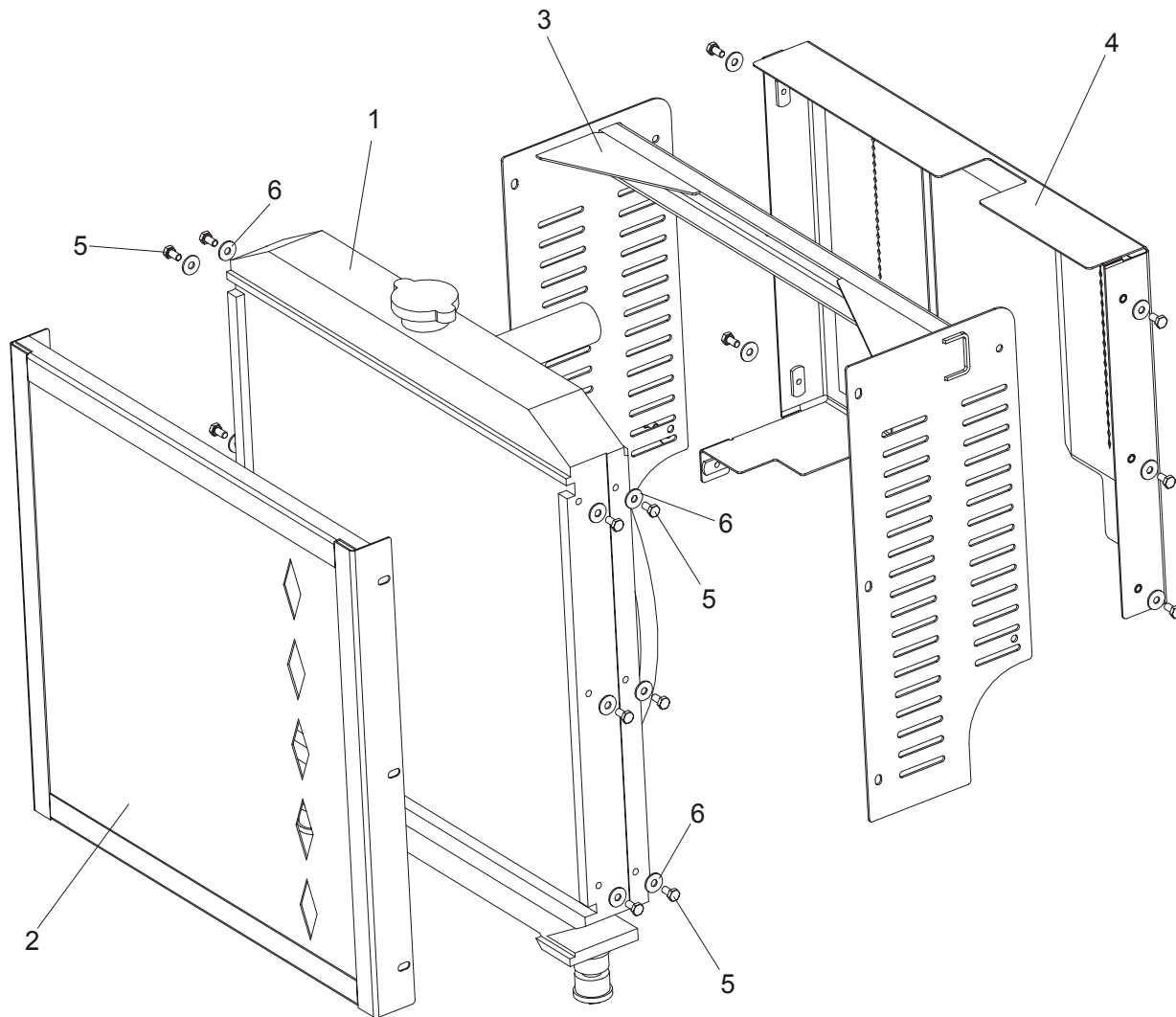

REF	DESCRIPTION (◆ Indicates Parts Available In Assemblies Only)	PART #	QTY.
1	RADIATOR ASSEMBLY, D42 A21/349(16292-72001)	088023	1
2	GUARD, KUBOTA RADIATOR FRONT	087967-1	1
3	BRACKET, RADIATOR MOUNT	088083-1	1
4	GUARD, KUBOTA RADIATOR REAR	088126-1	1
5	BOLT, M6X12-8.8 HEX HEAD FULL THREAD ZINC	F81001-7	19
6	WASHER, 6.5 FLAT ZINC	F81053-11	19

3.8 Alternator Assembly

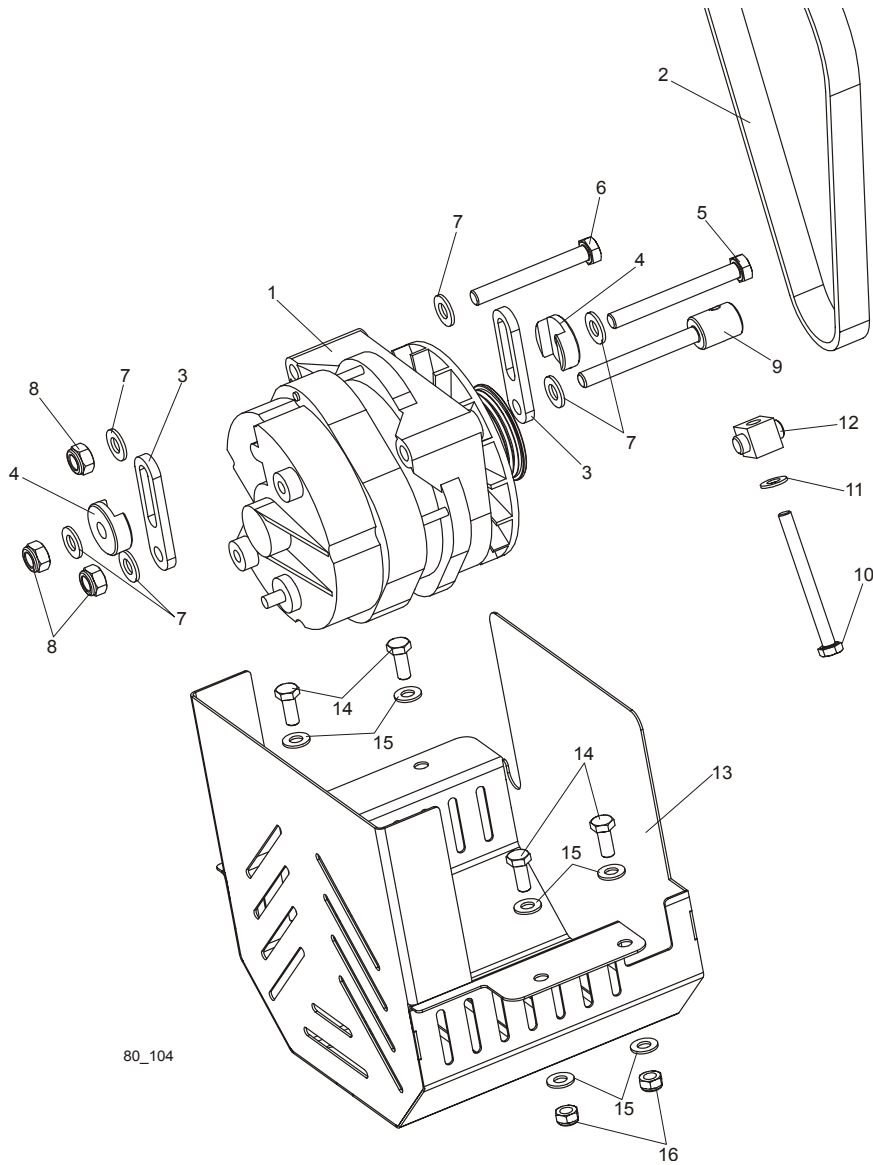

REF	DESCRIPTION (◆ Indicates Parts Available In Assemblies Only)	PART #	QTY.
1	ALTERNATOR, 190A (FOR LT70)	089466	1
2	BELT, 6PK 775 ALTERNATOR	089465	1
3	PLATE, D190 ALTERNATOR BELT TENSIONER	088933-1	2
4	WASHER, SPECIAL	088932-1	2
5	BOLT, M10X90-8.8-B HEX HEAD ZINC	F81003-66	1
6	BOLT, M10X80-8.8 HEX HEAD ZINC	F81003-51	1
7	WASHER, 10.5 ZINC FLAT	F81055-1	6
8	NUT, M10-8-B HEX NYLON ZINC LOCK	F81033-1	3

3 Replacement Parts

Alternator Assembly

9	BOLT, M10 SPECIAL	089472-1	1	
10	BOLT, M8X90-8.8 HEX HEAD FULL THREAD ZINC	F81002-16	1	
11	WASHER, 8.4 ZINC FLAT	F81054-1	1	
12	BLOCK, ALTERNATOR BELT TENSIONER	089473-1	1	
13	GUARD, 190A ALTERNATOR	089491-1	1	
14	BOLT, M8X20-8.8-B HEX HEAD FULL THREAD ZINC	F81002-4	4	
15	WASHER, 8.4 ZINC FLAT	F81054-1	8	
16	NUT, M8-8-B HEX NYLON ZINC LOCK	F81032-2	4	

3.9 Engine Guards

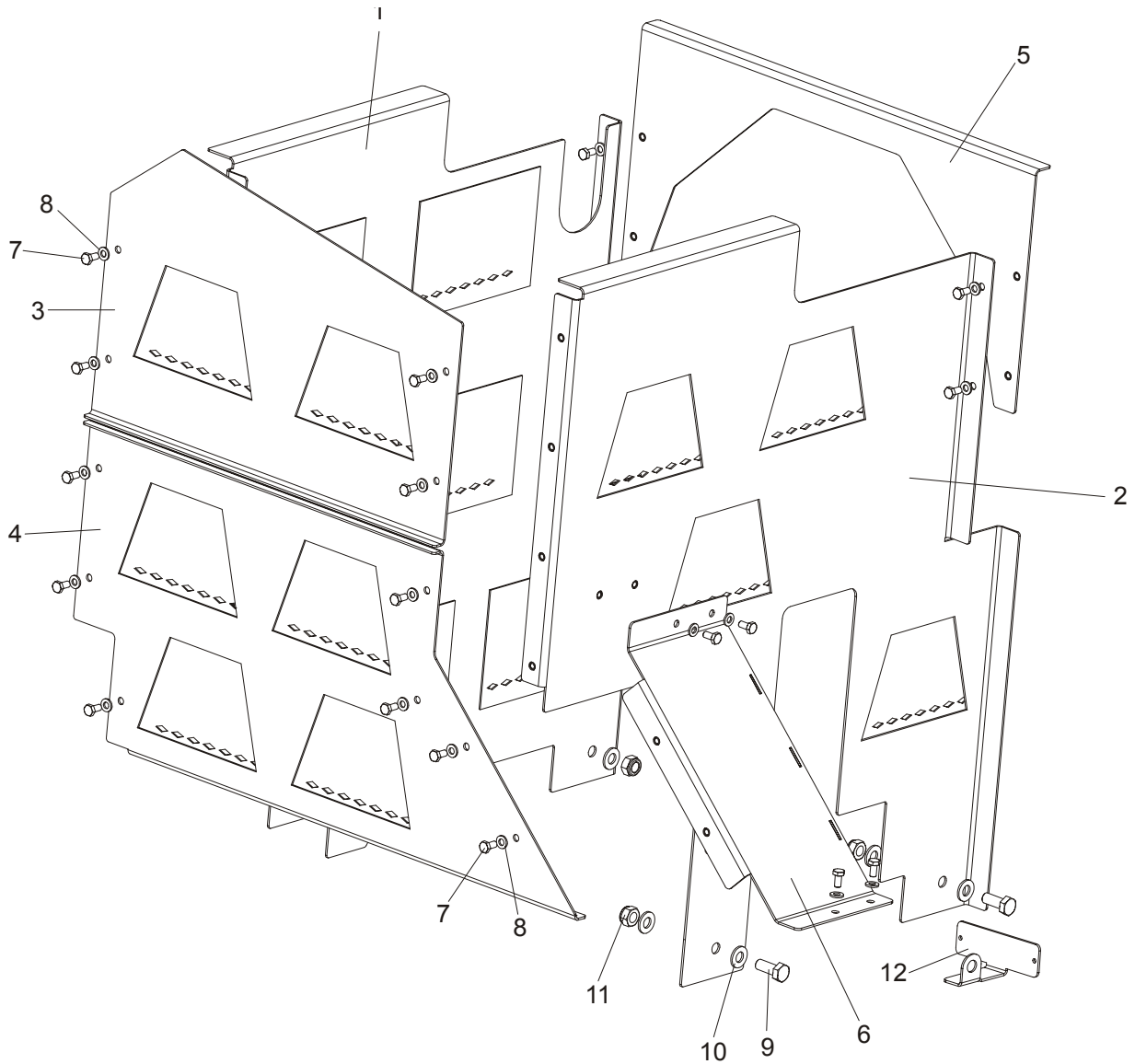

REF	DESCRIPTION (◆ Indicates Parts Available In Assemblies Only)	PART #	QTY.
	LT70 D42 ENGINE GUARDS	094499	1
1	Guard Weldment, Right Side Painted	094495-1	1
2	Guard, Left Side Painted	094497-1	1
3	Guard Weldment, Front Upper Painted	089496-1	1
4	Guard, Front Lower Painted	088988-1	1
5	Guard Weldment, Rear Painted	088980-1	1
6	Guard, D42 Main Drive Belt Side Painted	088983-1	1

3 Replacement Parts

Engine Guards

7	Bolt, M6x12-8.8 Hex Head Full Thread Zinc	F81001-7	17	
8	Washer, 6.4 Zinc Flat	F81053-1	17	
9	BOLT, M10X25-8.8 HEX HEAD FULL THREAD ZINC	F81003-11	4	
10	WASHER, 10.5 ZINC FLAT	F81055-1	4	
11	NUT, M10-8-B HEX NYLON ZINC LOCK	F81033-1	4	
12	BRACKET, SAFETY SWITCHES JUNCTION BOX	096873-1	1	

SECTION 4 ELECTRICAL WIRING DIAGRAMS, D42



IMPORTANT! When using a sawmill with the rewired control panel it is very important not to switch between saw head forward/backward movement until the saw head stops. Failure to do so may result in serious sawmill damage.



WARNING! When using the variable reverse speed wiring it is recommended that the operator should stop the head, turn the potentiometer to zero, engage reverse and then increase speed. Failure to do this may result in damage to the circuit. There is a protection in the circuit and if this is activated it will not allow the head to start the return movement until the potentiometer is set to zero.

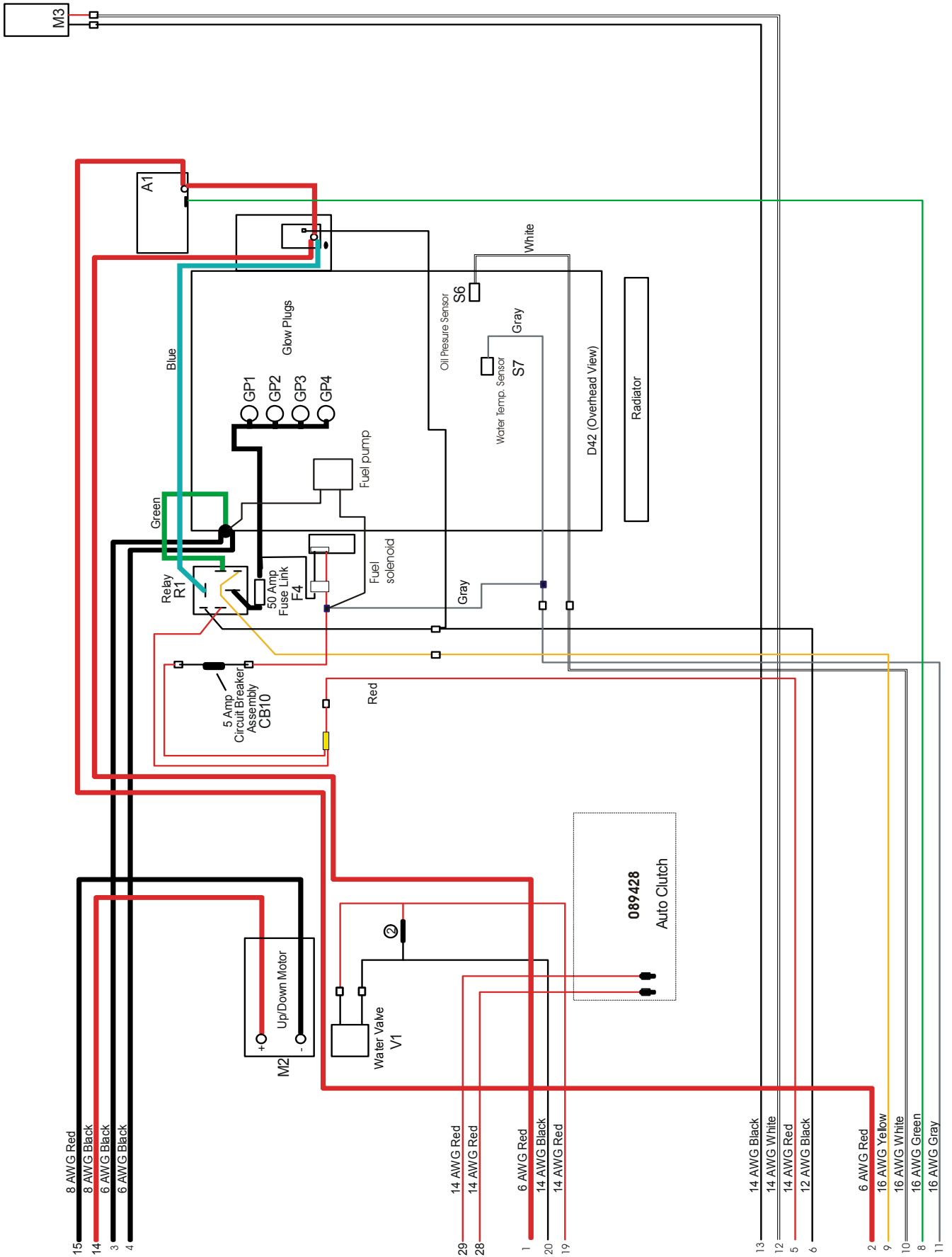

FIG. 4-1 D42 WIRING DIAGRAM (LT70 SAWMILLS).

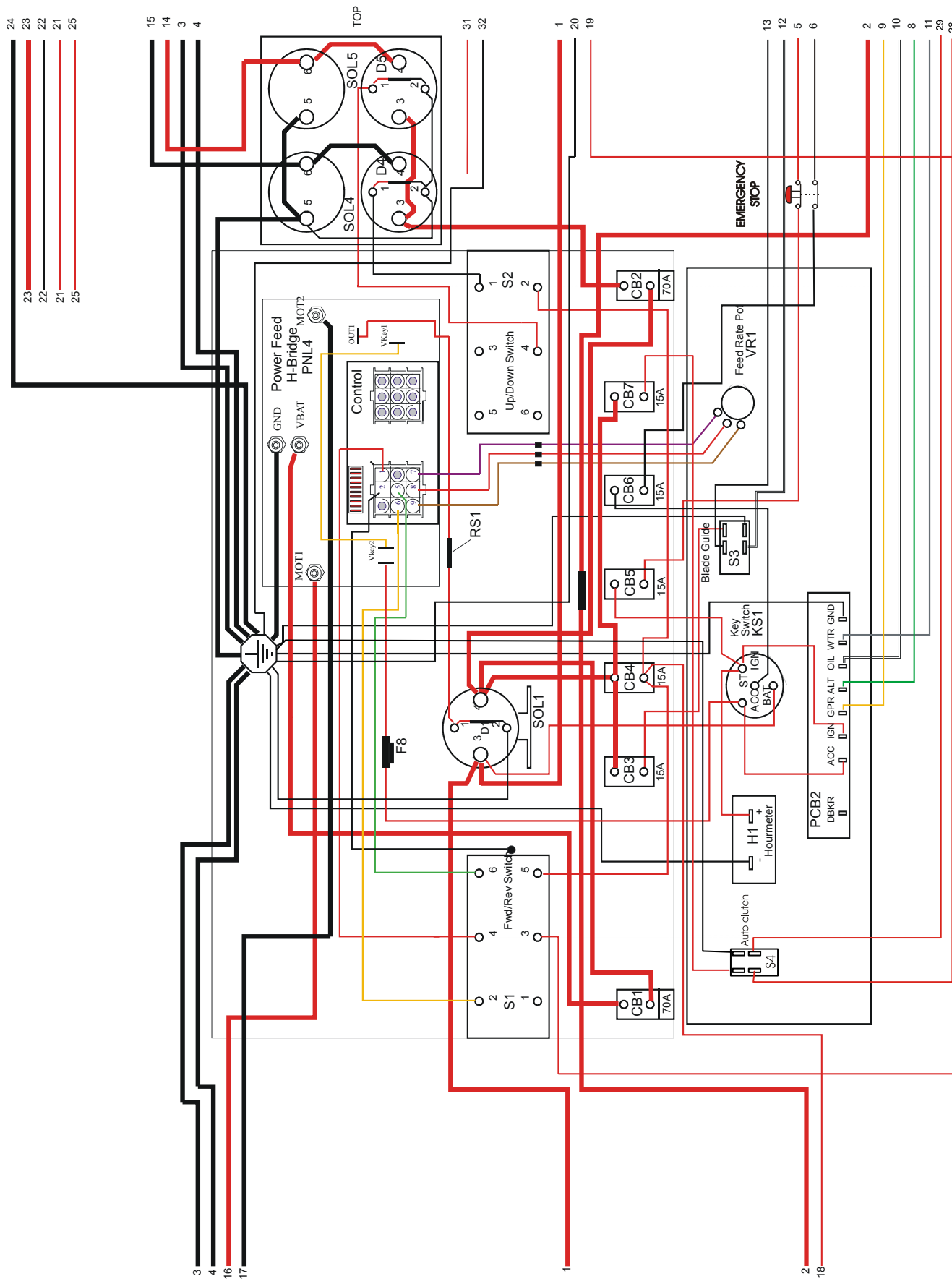

FIG. 4-2 D42 CONTROL BOX DIAGRAM).

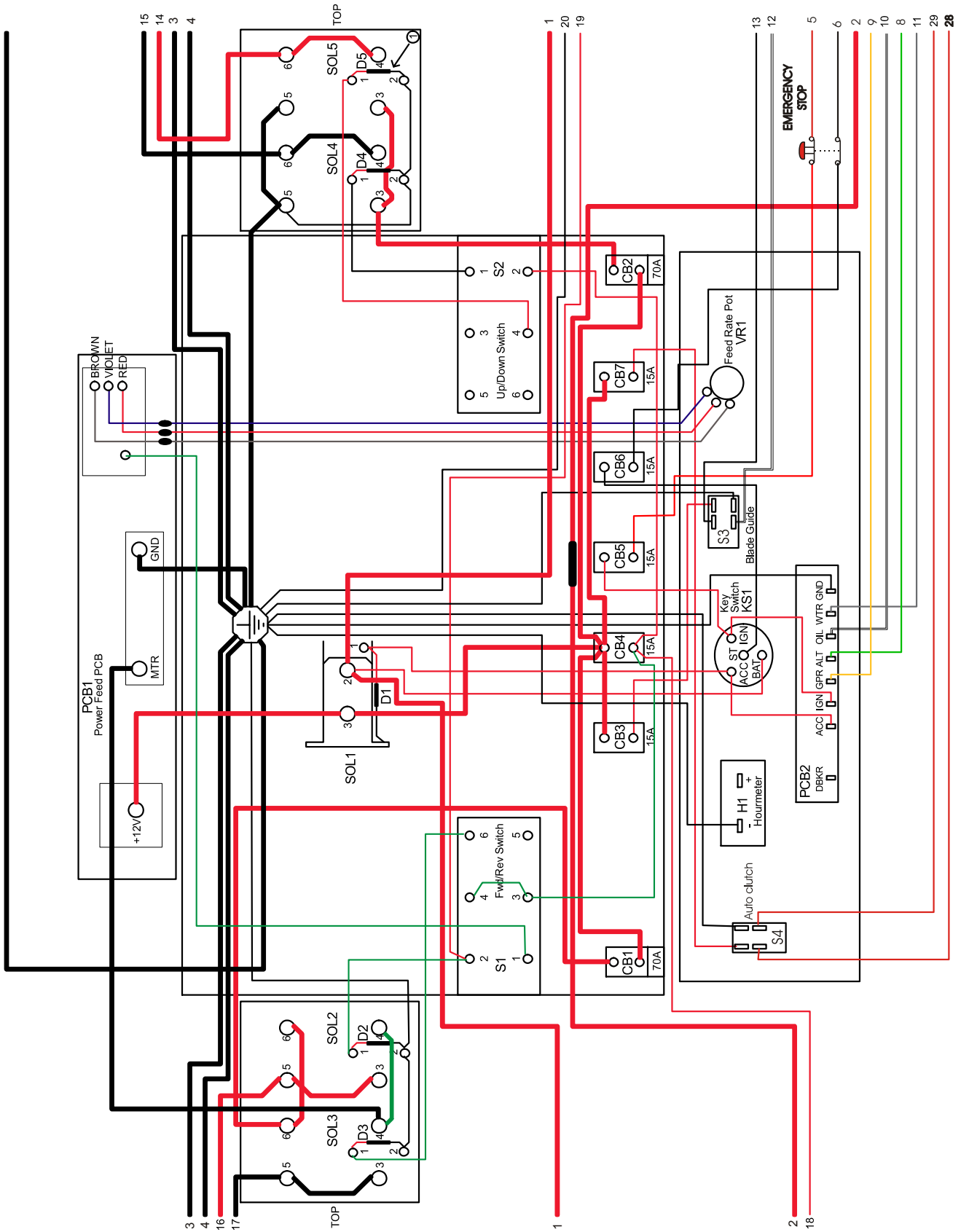

FIG. 4-4 D42 CONTROL BOX DIAGRAM (VARIABLE REVERS MOVEMENT SPEED).

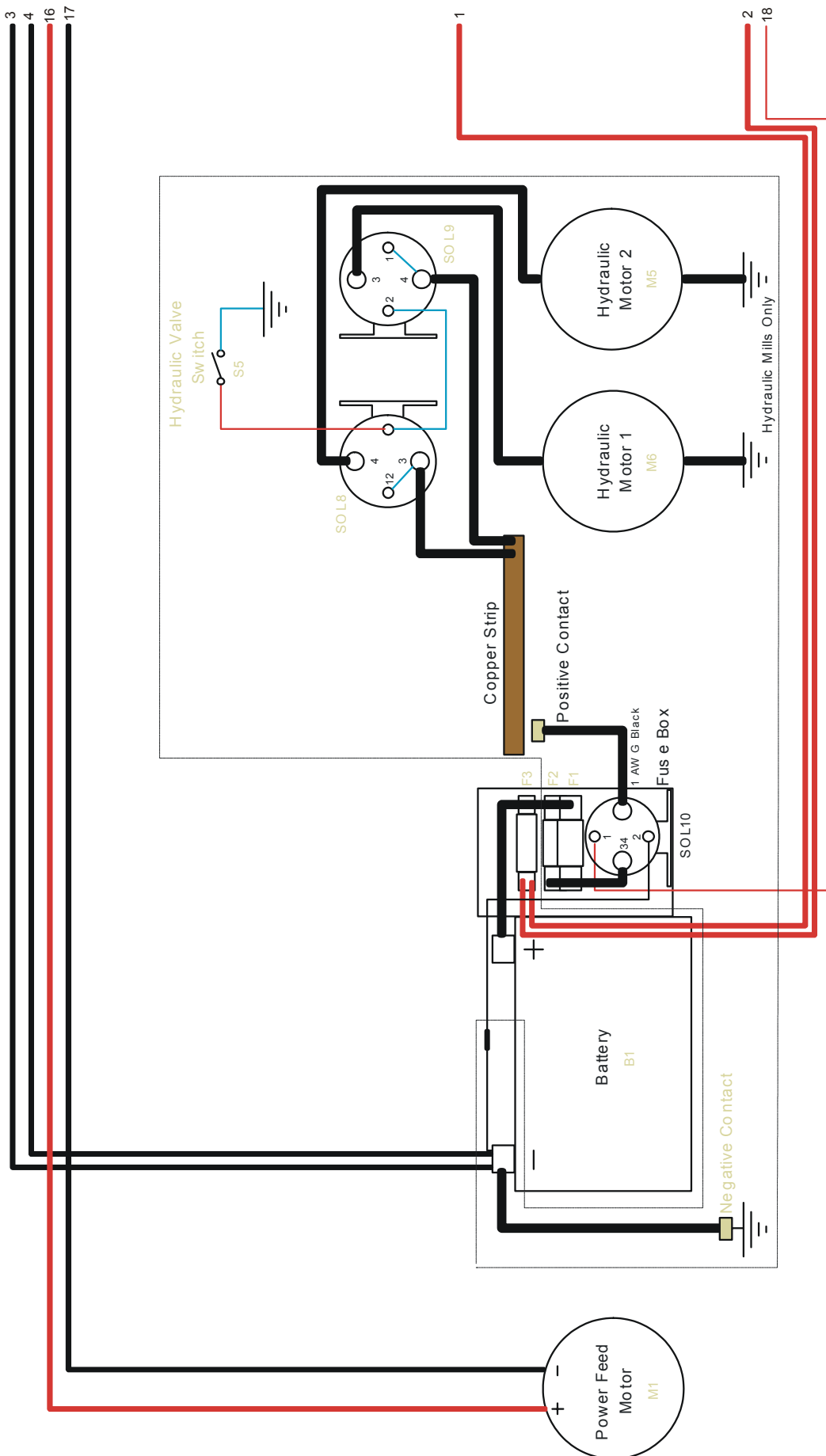

FIG. 4-5 D42 HYDRAULIC DIAGRAM.

Component List				
Item	Mfg. Part No.	Mfg.	Wood-Mizer Part No.	Description
A1	023 73 0	Wood-Mizer	023 73 0	Alternator, 14 0 Amp
B1	12 31 PMF	Deka	015475	Battery, 12 Volt (See Battery Specifications)
CB1	70-164 8-009	Mech. Prod.	015 52 7	Breaker, 70 Amp Manual Reset Panel Mount, Power Feed
CB2	70-164 8-009	Mech. Prod.	015527	Breaker, 70 Amp Manual Reset Panel Mount, Up/Down
CB3	CH304 07 -15	Cole-Hersee	E204 30	Breaker, 15 Amp Manual Reset, Blade Guide
CB4	CH304 07 -15	Cole-Hersee	E204 30	Breaker, 15 Amp Manual Reset, Accessory
CB5	CH304 07 -15	Cole-Hersee	E204 30	Breaker, 15 Amp Manual Reset, Ignition
CB6	CH304 07 -15	Cole-Hersee	E204 30	Breaker, 15 Amp Manual Reset, Start
CB7	CH304 07 -15	Cole-Hersee	E204 30	Breaker, 15 Amp Manual Reset, Board Return
CB1 0	024 45 3	Wood-Mizer	024 45 3	Breaker Assy, Water Temp Max Circuit
D1 - D5	087496	Wood-Mizer	087496	Diode Assembly, Solenoid Coil Chassis
D7	024 12 3	Wood-Mizer	024 12 3	Diode Assembly, Inductive Kick Protection (Setworks Only)
F1 , F2 ¹	RL-225	Gould	P1155 0	Fuse Link, 225 Amp, 250 Volt For Hydraulic + 12 Volt Circuit
F3	RL-150	Gould	023361	Fuse Link, 150A 250V For Main + 12 Volt Starter, Alternator
F4	N/A	N/A	02 45 97	Fuse Link, 50 Amp Kubota Glow Plug
GP 1-GP 4	16851- 65510	Kubota	092277	Glow Plug
H1	T14BH517BC9	ENM Corp.	015 40 1	Hour Meter, 12 Volt, Low Power T14 Series
KS 1	121801	General	P0 4350	Key Switch, 4-position (Accessory, Off, Ignition, Start)
M1	10 86 77 .00	Leeson	024 16 9	Motor, 3/4HP 12VDC TEFC Power Feed w/o Base
M2	10 86 78 .00	Leeson	015 17 4	Motor, 3/4HP 12VDC TEFC Up/Down w/Base
M3	P096 98 -1	Klauber	A10 36 5	Motor, 12 Volt Blade Guide Arm 53:1 Gear
M4	P096 98 -1	Klauber	A10 36 5	Motor, 12 Volt Board Return 53:1 Gear
M5 , M6 ¹	81 11	Monarch	P09955	Motor, 12 Volt Hydraulic Pump
PCB1	051667	Wood-Mizer	051667	Circuit Board, Control Box Power Feed
PCB2	089694	Wood-Mizer	089694	Board, LED Circuit (Diesel)
R1	1238 537	Bosch	092277	Relay, Glow Plug Timer
S1	26 01-AF 2-S 11	Square D	E20438	Drum Switch, Power Feed Fwd/Reverse Motor
S2	26 01 -AF2-S12	Square D	E20 44 0	Drum Switch, Up/Down Motor
S3	34 -591Q	Pollak	024 20 0	Toggle Switch, Blade Guide In/Out Motor
S4	34 -591Q	Pollak	02 42 00	Toggle Switch, Board Return Motor
S5 ¹	024 19 8	Wood-Mizer	024 19 8	Switch, Hydraulic Pump Levers
S6	15841- 39010	Kubota	028 54 7	Switch, Oil Pressure Sensor
S7	TM9A 230RQCG	Kubota	028 51 0	Switch, Water Temp Sensor
SO L1	015470	Stancor	015470	Solenoid 200 A 12V SPST
SO L4 -SO L5	58 6-911	Stancor	01 54 17	Solenoid, 200 A 12V DPST
SO L7	17454- 60010	Kubota	028 52 3	Solenoid, Fuel
SO L8 , SO L9 , SO L1 0 ¹	586- 902	Stancor	015470	Solenoid, 200 A 12V SPST Hydraulic Pump Motor
V1	G51190 14 5	Parker	016 28 0	Valve , Waterlube Solenoid
VR 1	E20519	Wood-Mizer	E20519	Potentiometer, Variable Resistance Power Feed