

D42 Engine

Safety, Operation, Maintenance & Parts Manual

LT70S DH rev. B6.00

LT70M DH rev. B6.00

LT70L DH rev. A9.00



Safety is our #1 concern! Read and understand all safety information and instructions before operating, setting up or maintaining this machine.

February 1998

Form #916

Table of Contents

Section-Page

SECTION 1	OPERATION	1-1
SECTION 2	MAINTENANCE	2-1
2.2	Cooling System	2-2
2.3	Air Filter & Pre-Cleaner	2-4
2.4	Fuel Filter	2-5
2.5	Battery	2-7
2.6	Alternator Belt	2-8
2.7	Radiator Fan Belt Adjustment	2-9
2.8	RPM Adjustments	2-10
2.9	Centrifugal Clutches Maintenance	2-13
SECTION 3	REPLACEMENT PARTS	3-1
3.1	Fuel Tank	3-1
3.2	Engine Mount Assembly	3-2
3.3	Engine Assembly	3-3
3.4	Primary Fuel Filter	3-6
3.5	Acceleration/Brake Assembly	3-7
3.6	Muffler Assembly	3-9
3.7	Radiator Assembly	3-10
3.8	Alternator Assembly	3-12
3.9	Engine Guards	3-14
SECTION 4	ELECTRICAL WIRING DIAGRAMS, D42	4-1

ABOUT THIS MANUAL

This manual is provided as a supplement to the equipment manufacturer's manuals. This manual provides information specific to the use of this equipment on the Wood-Mizer® sawmill. Refer to the sawmill operator's manual and manufacturer's manual before attempting to operate this equipment.



IMPORTANT! Read the sawmill operator's manual and engine manufacturer's manual for instructions and safety precautions before operating this equipment.

The information and instructions given in this manual do not amend or extend the limited warranties for the equipment given at the time of purchase.

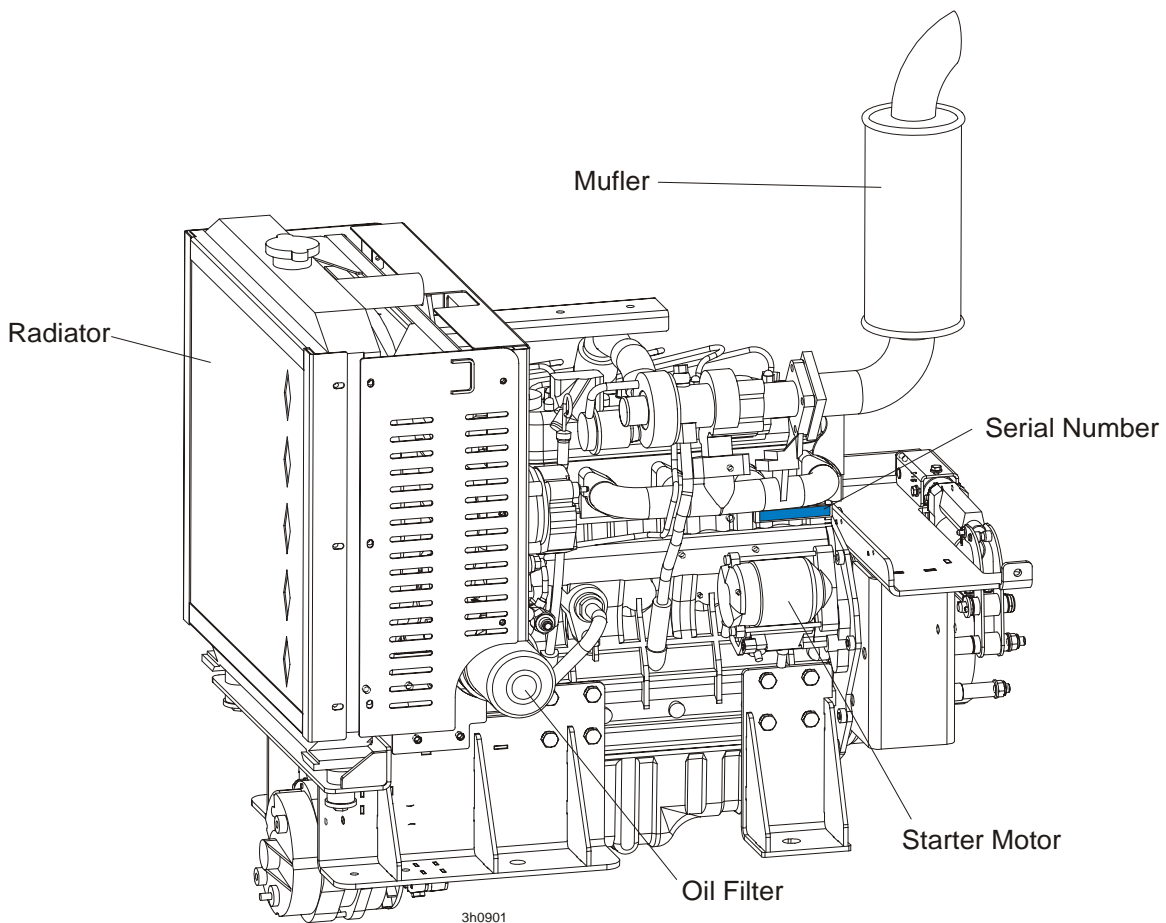











ENGINE COMPONENTS

SECTION 1 OPERATION

1.1 Starting The Engine

Control Lights

See **Figure 1-1**. The following indicator lights are located on the sawmill control panel.

-  *Alternator Charge Indicator*: Lights up if the alternator is not charging the battery.

-  *Engine Temperature Indicator*: Lights up if the engine is overheating. A circuit breaker assembly in the engine harness will shut the engine off if the engine overheats. Turn the key switch off and allow the engine to cool for a period of time before restarting. If the overheating condition persists, stop operating the engine until the condition is corrected. The engine will automatically switch to low idle if an overheating condition occurs.

-  *Key Switch Indicator*: Lights up when the key is in either the on or accessory (#1 or #3) position.

-  *Oil Indicator*: Lights up if the oil pressure is too low.

-  *Glow Plug Indicator*: Lights up after the key has been turned to the on (#1) position.

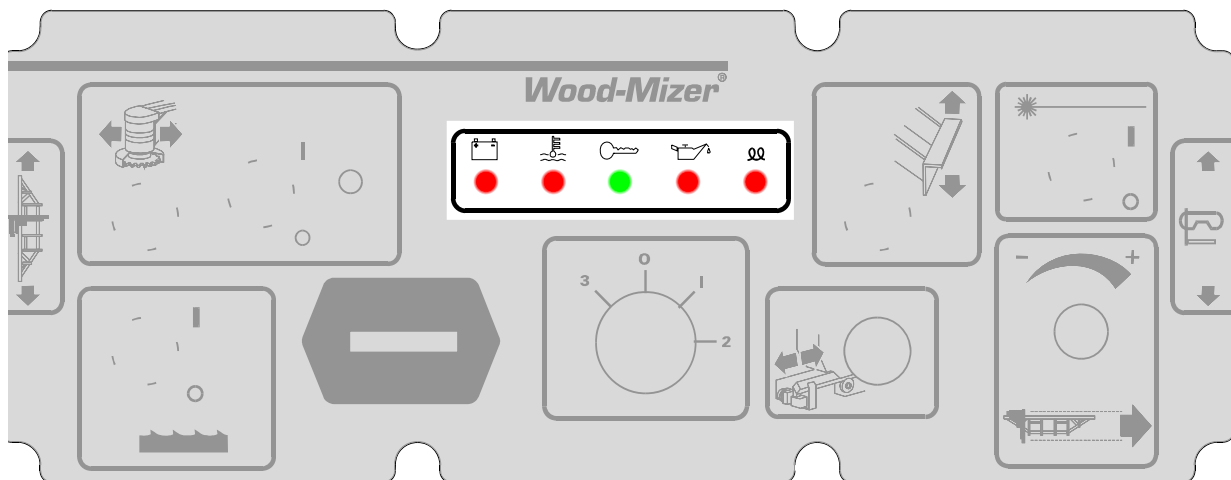

FIG. 1-1

Engine Start



DANGER! Always be sure the blade is disengaged and all persons are out of the path of the blade before starting the engine. Failure to do so will result in serious injury.

DANGER! Operate your engine/machine only in well ventilated areas. The exhaust gases of your engine can cause nausea, delirium and potentially death unless adequate ventilation is present.

DANGER! Never operate an engine with a fuel or oil leak. The leaking fuel or oil could potentially come in contact with hot surfaces and ignite into flames.



WARNING! Be sure the power feed switch is in the neutral position before turning the key switch to the on (#1) or accessory (#3) position. This prevents accidental carriage movement which may cause serious injury or death.

WARNING! Do not operate engine without proper and operational spark arrester/muffler. Sparks emitted from the engine exhaust could ignite surrounding materials, causing serious injury or death.



CAUTION! Do not crank starter for more than 7 seconds at one time during starting attempts. Damage to the engine may result.

CAUTION! Let engine idle for 2 minutes before applying load to prevent engine damage.

1. See the engine manufacturer's manual for lubricating oil recommendations for specific temperature ranges.
2. Use the best quality diesel fuel for below freezing starting.
3. Turn the key switch on the control panel to the on (#1) position.
4. Wait until the glow plug indicator goes out.
5. Turn the key switch to the start (#2) position and release.

Engine Shutoff

CAUTION! A minimum 2 minute idle time is recommended to allow the battery charge to recover before the engine is shut off.

Turn the key switch to the off (#0) position.

SECTION 2 MAINTENANCE

Refer to the manufacturer's manual for maintenance intervals and procedures unless otherwise instructed in this manual. Follow the manufacturer's recommendations for dusty conditions.



IMPORTANT! This manual only provides information about additional procedures or procedures to be performed at different time intervals than found in the manufacturer's manuals. Refer to the manufacturer's manual for complete maintenance instructions.

2.1 Safety

Use caution when performing maintenance or service to the engine.



DANGER! Always be aware of and take proper protective measures against rotating shafts, pulleys, fans, etc. Always stay a safe distance from rotating members and make sure that loose clothing or long hair does not engage rotating members resulting in possible injury.

DANGER! Engine components can become very hot during operation. Avoid contact with any part of a hot engine. The exhaust components of your engine are especially hot during and following operation. Contact with hot engine components can cause serious burns. Therefore, never touch or perform service functions on a hot engine. Allow the engine to cool sufficiently before beginning any service function.



WARNING! Remove the blade before performing any engine service. Failure to do so may result in serious injury.

WARNING! Always wear proper and necessary safety equipment when performing service functions. Proper safety equipment includes eye protection, breathing protection, hand protection and foot protection.



This symbol identifies the interval (hours of operation) at which each maintenance procedure should be performed. "AR" signifies maintenance procedures which should be performed as required.

2.2 Cooling System



Clean the radiator fins every 8 hours of operation. Spray the radiator with water from a hose or compressed air to clean sawdust from the radiator fins. Do not use a pressure sprayer.



CAUTION! Failure to keep the radiator fins clear of sawdust and/or dirt may cause the engine to overheat resulting in damage to the engine.



CAUTION! Do not spray the radiator with water when the engine is hot.



CAUTION! Do not open the radiator cap or reservoir cap when the engine is hot.



Every 8 hours of operation check the coolant level on the coolant reservoir. When engine is cold the coolant level should be above the LOW level.

For the aluminium radiator use only glycol solution (1l. of glycol concentrate for 1l. of dis-

tilled water).

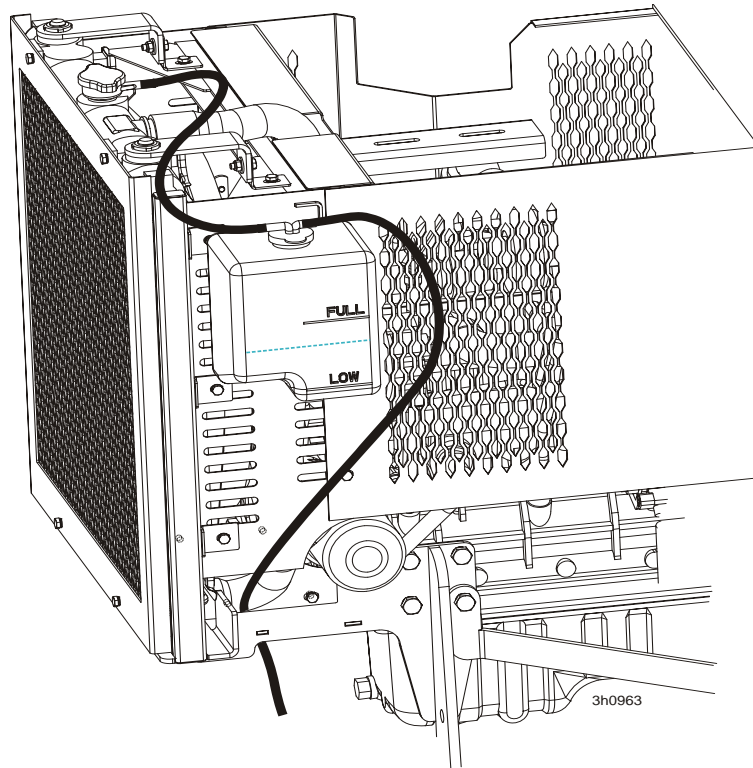

FIG. 2-0

2.3 Air Filter & Pre-Cleaner



WARNING! Always wear proper and necessary safety equipment when performing service functions. Proper safety equipment includes eye protection, breathing protection, hand protection and foot protection.

4

Service the pre-cleaner every four hours of operation. Service by gently shaking excess sawdust and debris from the foam piece.

8

Clean the air filter (air cleaner element) and pre-cleaner (element wrapper) every eight hours of operation. See the engine manual for further instructions.

200

Replace the air filter (cleaner) every 200 hours of operation.

2000

Replace the pre-cleaner (element wrapper) every 2000 hours of operation.

2.4 Fuel Filter

200

See **Figure 2-1**. Replace the primary fuel filter and prefilter cartridge every 200 hours. After replacing any of the two filter cartridges, loosen the air bleed screw on the main filter and turn the key switch on the control panel to #1 position and wait until fuel begins to flow from the valve and is free of air bubbles. Turn the key to #0 position. Tighten the bleed screw.



FIG. 2-1

2 Maintenance

Fuel Filter

See Figure 2-2. Inspect the water separator bowl on the prefilter periodically and drain the bowl as required by turning the drain cap counterclockwise as viewed from the bottom.



FIG. 2-2

2.5 Battery



Check the battery electrolyte level every 50 hours of operation. See manufacturer's manual for instructions.



DANGER! Batteries expel explosive gases. Keep sparks, flames, burning cigarettes, or other ignition sources away at all times. Always wear safety goggles and a face shield when working near batteries. Failure to do so will cause serious injury.¹



WARNING! Battery posts, terminals and related accessories contain lead and lead compounds, chemicals known to the State of California to cause cancer and reproductive harm. Wash hands after handling.

1. Battery Council International, copyright 1987

2.6 Alternator Belt

AR The belt tension should be checked after the first 100 hours of operation, when the battery is not charging properly or when the alternator belt is squealing. If the battery continues to not charge properly or the belt continues to squeal after the initial belt adjustment, replace the belt.

1. Turn the key switch to OFF (#0) and remove the key.
2. Remove the alternator cover.

See Figure 2-3.

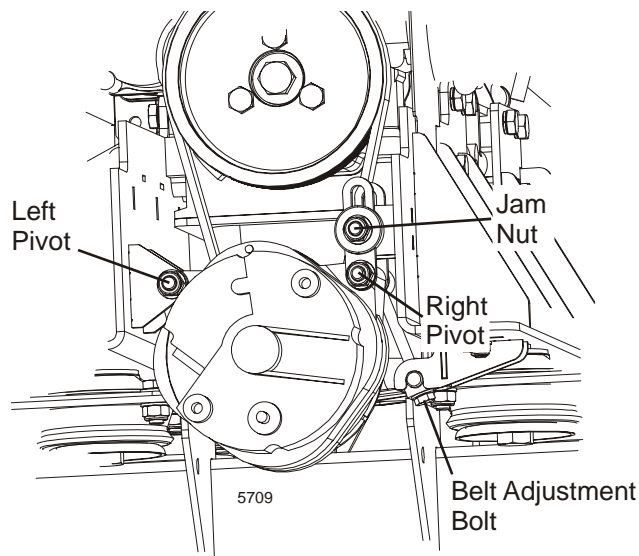

FIG. 2-3

3. Loosen the left pivot, right pivot and jam nut.
4. Turn the belt tension adjustment bolt clockwise to tighten the belt, counterclockwise to loosen the belt. Adjust the bolt until the proper belt tension is achieved.



CAUTION! Do not overtighten the alternator belt. Damage to the alternator will occur.

5. After the alternator belt has been tensioned, tighten the jam nut. Tighten the left and right pivots and replace the belt covers.

2.7 Radiator Fan Belt Adjustment



The fan belt tension should be checked after the first 100 hours of operation, when the engine is overheating or when the fan belt is squealing. If the engine continues overheating or the belt continues to squeal after the initial belt adjustment, replace the belt.

1. Turn the key switch to OFF (#0) and remove the key.
2. Remove the radiator covers.
3. Loosen the jam nut (shown below).
4. Tension the fan belt properly by hand.
5. Tighten the jam nut and replace the radiator covers.

See Figure 2-4.



FIG. 2-4

2.8 RPM Adjustments



WARNING! Remove the blade before performing any engine service. Failure to do so may result in serious injury.



CAUTION! The engine RPM should be adjusted when the engine is warmed up to its working temperature.

200

Check the RPM with a tachometer after the first 20 hours of operation and every 200 hours thereafter. High-end RPM should be 3000 RPM and low-end RPM should be 1150 RPM.

Before checking the RPM, make sure belt and brake tensions are correct (See Sawmill Maintenance). Also check oil, fuel, and coolant levels.

To adjust brake, set the turnbuckle so that the braking time is about 5-7 seconds.

Make sure the throttle cable does not affect the engine RPM when the blade switch is disengaged. Make sure the cable is not bent or kinked.

1. When the blade switch is disengaged, the throttle cable should be taut but the spring not extended. When the blade switch is engaged, the throttle spring should extend 1/8" to 1/4" (3-6 mm).



CAUTION! Do not extend the throttle spring over 1/4". Excessive tension may cause the throttle cable to fail prematurely.

See **Figure 2-5**. Use the adjustments shown below to adjust the engine RPM (3000[±50] high-end, 1150[±50] idle).

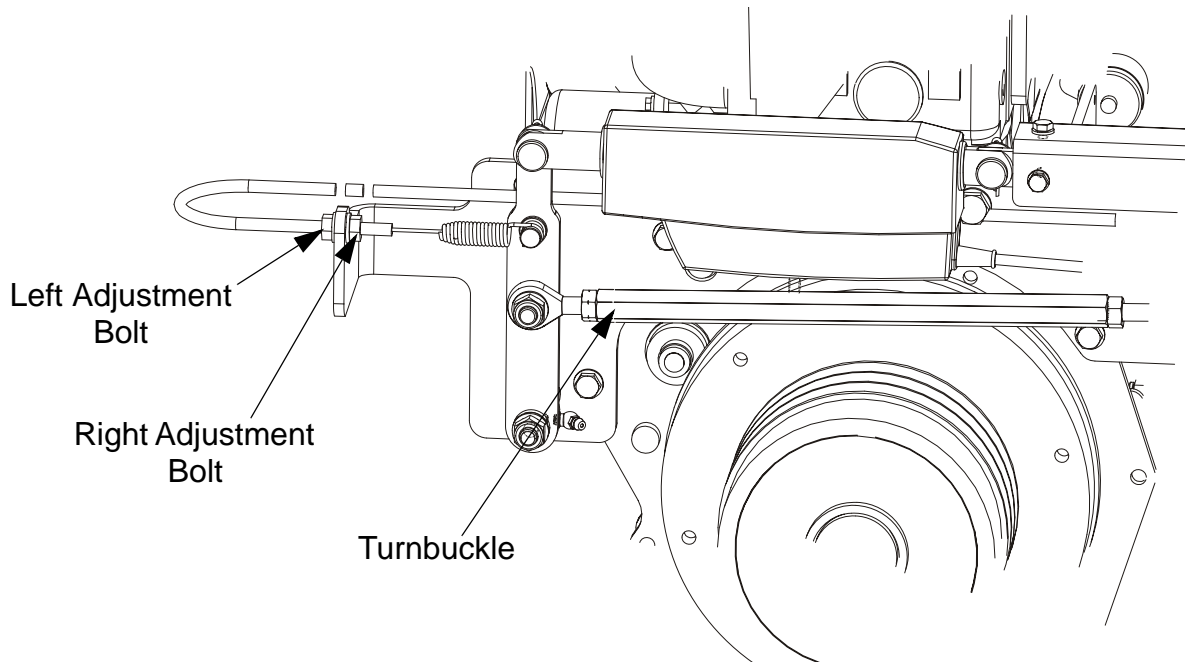

FIG. 2-5



CAUTION! Do not adjust the high-end RPM above 3200. Doing so may cause damage to the engine.

NOTE: When using the 097779 clutch (with reduced diameter) for hardwood cutting, adjust the high-end RPM at 2900.

2. After the RPM settings are made, shut the engine off. Tighten the throttle cable by engaging the blade switch. Check the throttle cable at the upper cable mounting bracket. The cable should be centered in the cable housing. If necessary, loosen the upper bracket mounting bolts and adjust the bracket so the cable housing is centered around the cable. Retighten the upper cable bracket mounting bolts.

See Figure 2-6.

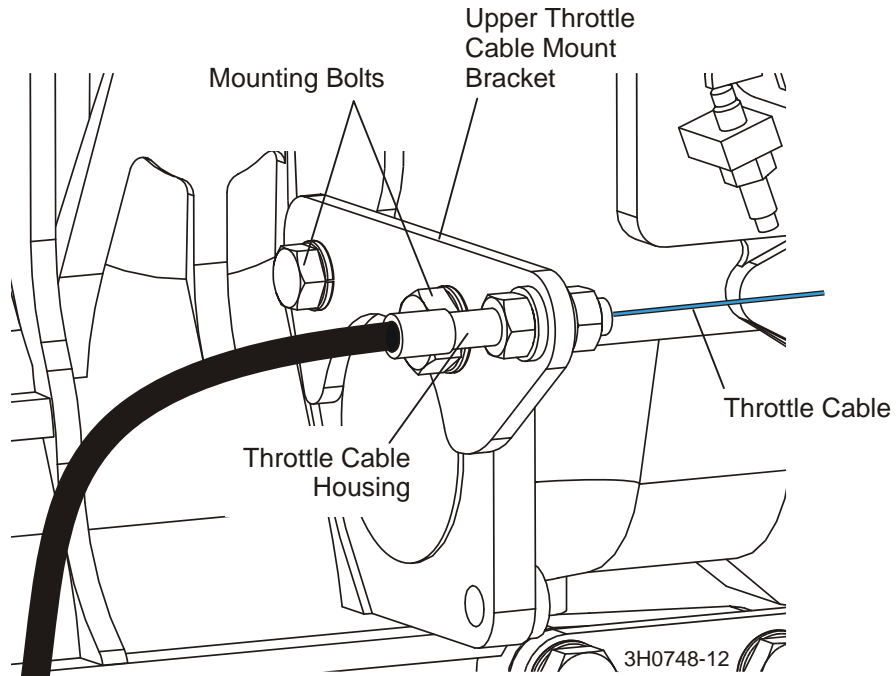

FIG. 2-6



CAUTION! Failure to properly center the throttle cable in the cable housing may result in premature cable wear.

2.9 Centrifugal Clutches Maintenance

Always shut off the engine and allow the sawmill to come to a complete stop before performing any engine service.

Before replacing the extension springs clean the clutch with compressed air.

250 The extension springs should be replaced every 250h of operation. Check the clutch linings and replace them if they are worn to a thickness smaller than 1.5 mm.

Idling r.p.m., brake strap tension and clutch braking time should be checked after every extension springs replacement.

See Picture 2-7.

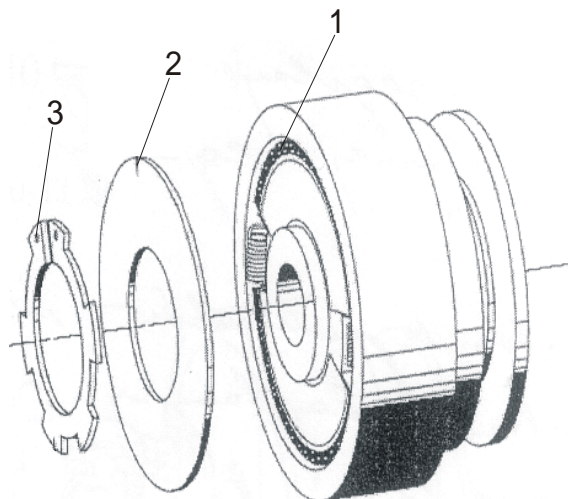

PIC. 2-7

Clutch linings and extension springs replacement:

1. Remove retaining ring (Fig.2-7 pos.3) and the cover plate (Fig.2-7 pos.2).
2. Pull out the linings and flyweights (Fig.2-7 pos.1).
3. Remove worn linings from the flyweights.
4. Fit new linings and extension springs. The hook opening should be turned outside!
5. Install the cover plate and secure with retaining ring.

2

Maintenance

Centrifugal Clutches Maintenance

The Seeger-L-circlip is slightly conical in shape and applies a degree of pressure on the plate. It must be fitted with the radial fingers of the circlip pressing towards the cover ensuring at the same time that the circlip is fully seated in the hub groove.



CAUTION! Clutches must be fully assembled with the drum in position and cover plated fastened before the driving machine is started.

SECTION 3 REPLACEMENT PARTS

3.1 Fuel Tank

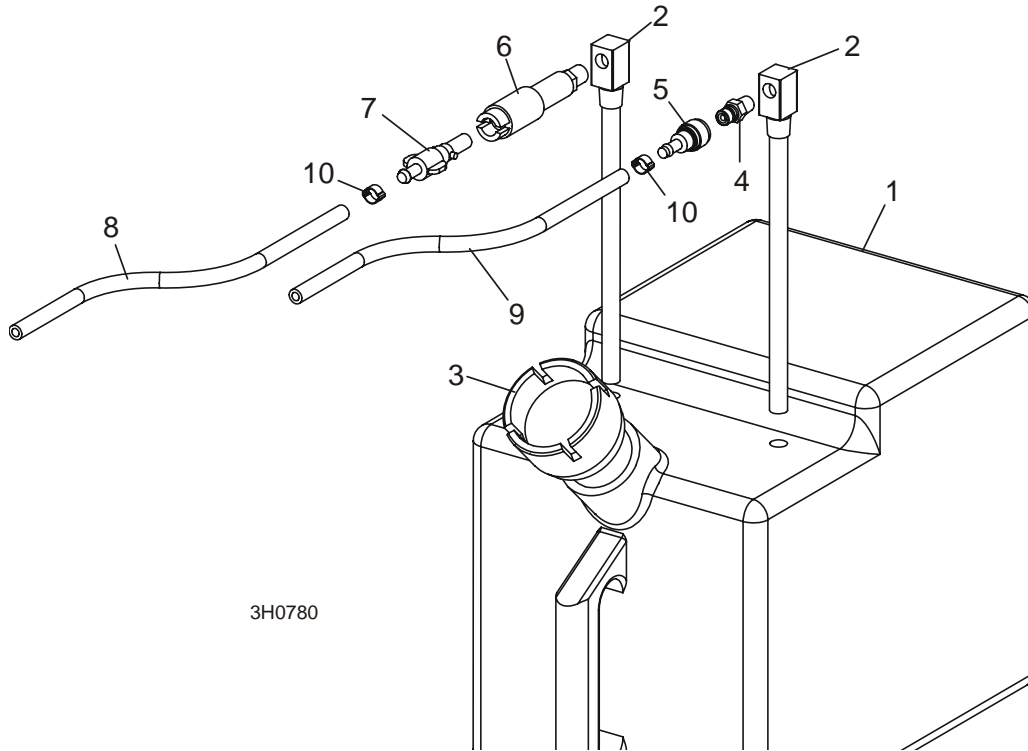

REF	DESCRIPTION (◆ Indicates Parts Available In Assemblies Only)	PART #	QTY.	
	TANK ASSEMBLY, 5 GALLON GREEN DIESEL	A12132	1	
1	Tank, 5 Gallon Green Fuel	P12166	1	◆
2	Pickup, 9" Fuel	P12172	2	
3	Cap, 3/5 Gallon Fuel Tank	P09683	1	
4	Fitting, 1/4" NPT Male Quick Disconnect	015583	1	
5	Fitting, Female Quick Disconnect Barb	015582	1	
6	Fitting, 1/4" NPT Plastic Female Disconnect	P12175	1	
7	Fitting, 1/4" Barb Plastic Male Disconnect	P12176	1	
8	HOSE, 1/4" ID FUEL	P642	7.17 Ft	
9	HOSE, 5/16" ID FUEL	016338	9 Ft.	
10	CLAMP, 7/32 - 1/2 HOSE	P649	6	
	ADDITIVE, DIESEL FUEL 16OZ BOTTLE	004878 ¹	1	

¹ Stanadyne Performance Formula helps eliminate contaminants and water in fuel, prevents gelling in cold weather, and improves lubrication of fuel system parts. 16 oz. bottle treats 60 gallons of diesel fuel.

3.2 Engine Mount Assembly

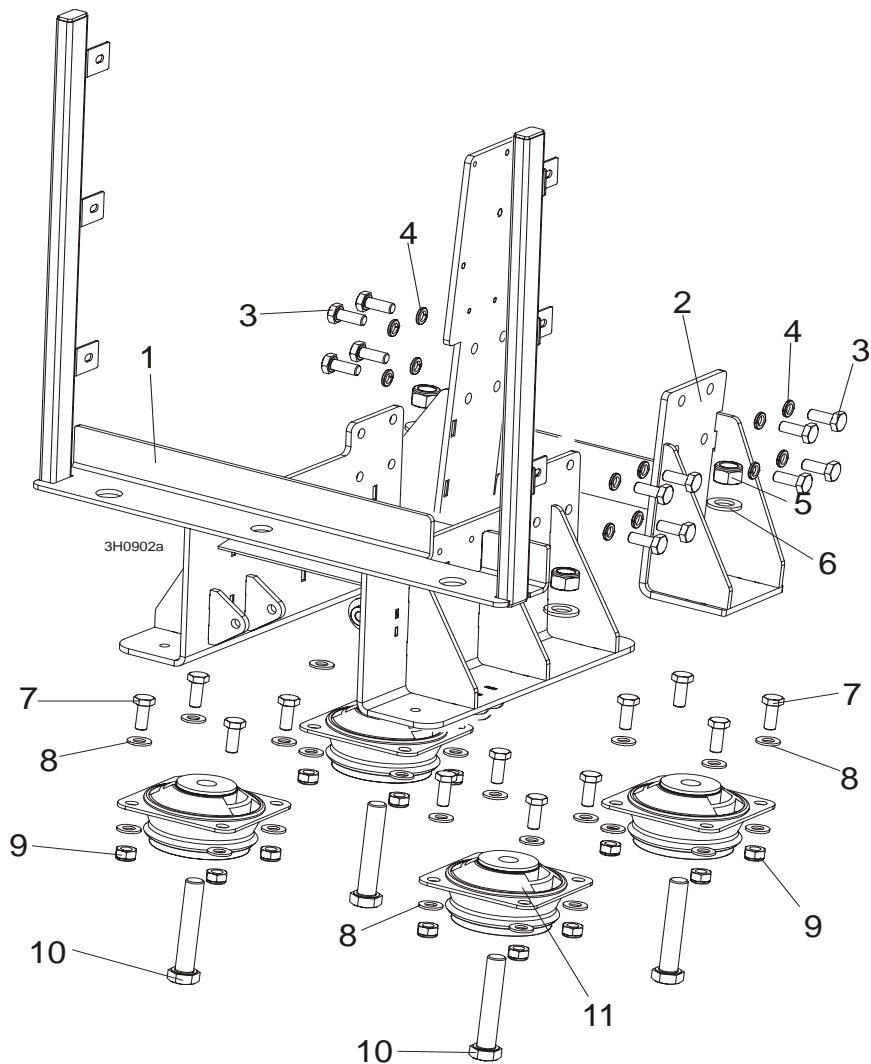

REF	DESCRIPTION (◆ Indicates Parts Available In Assemblies Only)	PART #	QTY.
1	MOUNT WELDMENT, REAR D42 ENGINE	097588-1	1
2	MOUNT WELDMENT, FRONT D42 ENGINE	089459-1	1
3	BOLT, M10X1.25X25-8.8-A HEX HEAD FULL THREAD ZINC	F81003-29	16
4	WASHER, 10.2 ZINC SPLIT	F81055-2	16
5	NUT, M16-8 HEX NYLON ZINC LOCK	F81036-2	4
6	WASHER, 17 ZINC FLAT	F81058-1	4
7	BOLT, M10X25 8.8 HEX HEAD FULL THREAD	F81003-31	16
8	WASHER, 10.5 ZINC FLAT	F81055-1	32
9	NUT, M10-8-B HEX NYLON ZINC LOCK	F81033-1	16
10	BOLT, M16X90-8.8 HEX HEAD ZINC	F81006-17	4
11	SHOCK ABSORBER, STEEL & RUBBER	088570	4

3.3 Engine Assembly

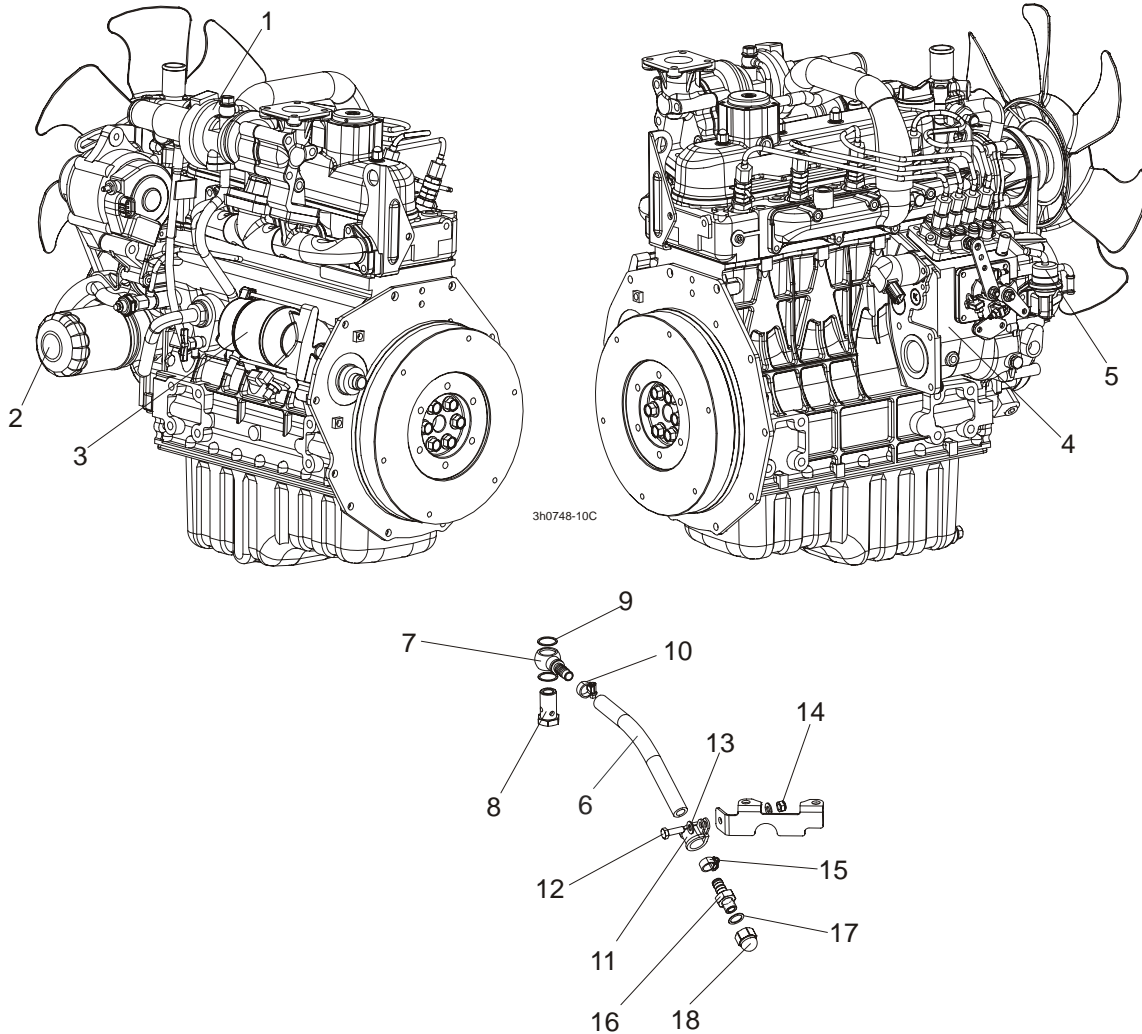

REF	DESCRIPTION (◆ Indicates Parts Available In Assemblies Only)	PART #	QTY.
	ENGINE, KUBOTA V1505-T-E3B-EU-XL1	100571	1
1	Turbocharger, Kubota	097738	1
	Belt, Kubota Fan	097739	1
	Radiator Fan	097740	1
	Filter, Kubota D42 Air B53/207	088025	1
	Filter Cartridge, Kubota D42 Air	097741	1
	Filter, Kubota D42 fuel	088024	1
	Filter Cartridge, Kubota Fuel D42	097742	1
2	Filter, Kubota Oil	097743	1
	Gasket Kit, Kubota Lower	097744	1

3

Replacement Parts

Engine Assembly

	Gasket Kit, Kubota Upper	097745	1	
	Gasket, Kubota Muffler	097746	1	
	Gasket, Kubota Fuel Injector	097747	1	
	Gasket, Kubota Fuel Transfer Pump	097748	1	
	Gasket, Kubota Head	097749	1	
	Gasket, Kubota Oil Drain Plug	097750	1	
	Gasket, Kubota Stop Solenoid	097751	1	
	Gasket, Kubota Thermostat	097752	1	
	Gasket, Kubota Valve Cover	097753	1	
	Gasket, Kubota Water Pump	097754	1	
	Gasket, Kubota Exhaust Manifold	097755	1	
	Glow Plug, Kubota	097756	1	
	Injector, Kubota Fuel	097757	1	
	Injection Sprayer, Fuel Kubota	097758	1	
3	Motor, Kubota Starter	097759	1	
4	Pump, Kubota Fuel Injector	097761	1	
5	Pump, Kubota Fuel Transfer	097762	1	
	Pump, Kubota Water	097763	1	
	Pulley, D42 Kubota Idler Ptd	087959-1	1	
	Radiator Parts (See Section 1.5)			
	Sending Unit, Kubota Heat Sensor	097764	1	
	Solenoid, Kubota Stop	097765	1	
	Switch, Kubota Oil Pressure	097766	1	
	Thermostat, Kubota	097767	1	
	Seal, D42 Crankshaft Front	097788	1	
	Seal, D42 Crankshaft Rear	097789	1	
	HARNESS ASSEMBLY, KUBOTA DIESEL ENGINE	088144	1	
	Breaker Assembly, Water Temp Max Circuit	N/A	1	
	Socket, Glow Plug Relay w/Fuse Holder	N/A	1	
	Fuse Link, 50 Amp	N/A	1	
	Relay, Glow Plug	088143	1	
	RELAY, 40A, 12V	021238	1	
	HOSE, D42 ENGINE OIL DRAIN	091774	1	
6	Hose, Oil Drain	091777	1	
7	End, BANJO M22x1.5x1/2 ZMB 600-22-08	091773	1	
8	Bolt, BANJO M22x1.5 ZMB 610-22/1.5	091772	1	
9	Washer, 22 Copper	F81061-5	2	
10	Clamp, 12-20mm Diameter Hose	F81080-3	1	
11	Ring, RSGU 1.20/20 Hose Bracket	F81087-2	1	
12	Bolt, M8x25-8.8-B Hex Head Full Thread Zinc	F81002-5	1	
13	Washer, 8.4 Flat Zinc	F81054-1	2	
14	Nut, M8-8-B Hex Nylon Zinc Lock	F81032-2	1	
15	Clamp, 12-20mm Diameter Hose	F81080-3	1	

16	End, Oil Drain Hose	091776	1	
17	Washer, 16 Copper	F81058-3	1	
18	Nut, M16x1.5 Hex Domed Cap Zinc	F81036-7	1	

3 Replacement Parts

Primary Fuel Filter

3.4 Primary Fuel Filter

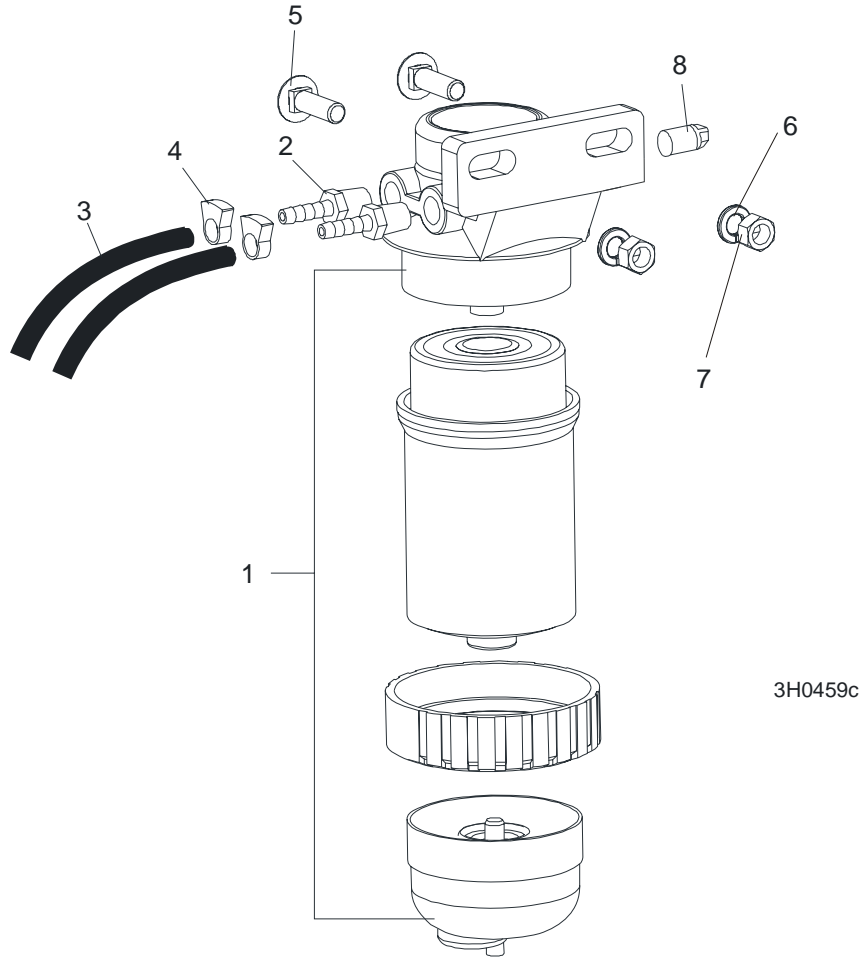

REF	DESCRIPTION (◆ Indicates Parts Available In Assemblies Only)	PART #	QTY.
1	FILTER ASSEMBLY, STANDADYNE FUEL FPV-5,7 04WP40/3	088101	1
2	FITTING, 8MM, FILTR FPV-5,7	088094	2
3	HOSE, 5/16" ID FUEL	R80703-2	2m
4	CLAMP, 11-17MM HOSE	F81080-3	2
5	BOLT, 3/8-16 X 1 1/4" CARRIAGE HEAD	F05007-11	6
6	WASHER, 3/8" SPLIT LOCK	F05011-4	6
7	NUT, 3/8-16 HEX	F05010-1	6
8	FITTING, 1/4" NPT PLUG	P05498	2

3.5 Acceleration/Brake Assembly

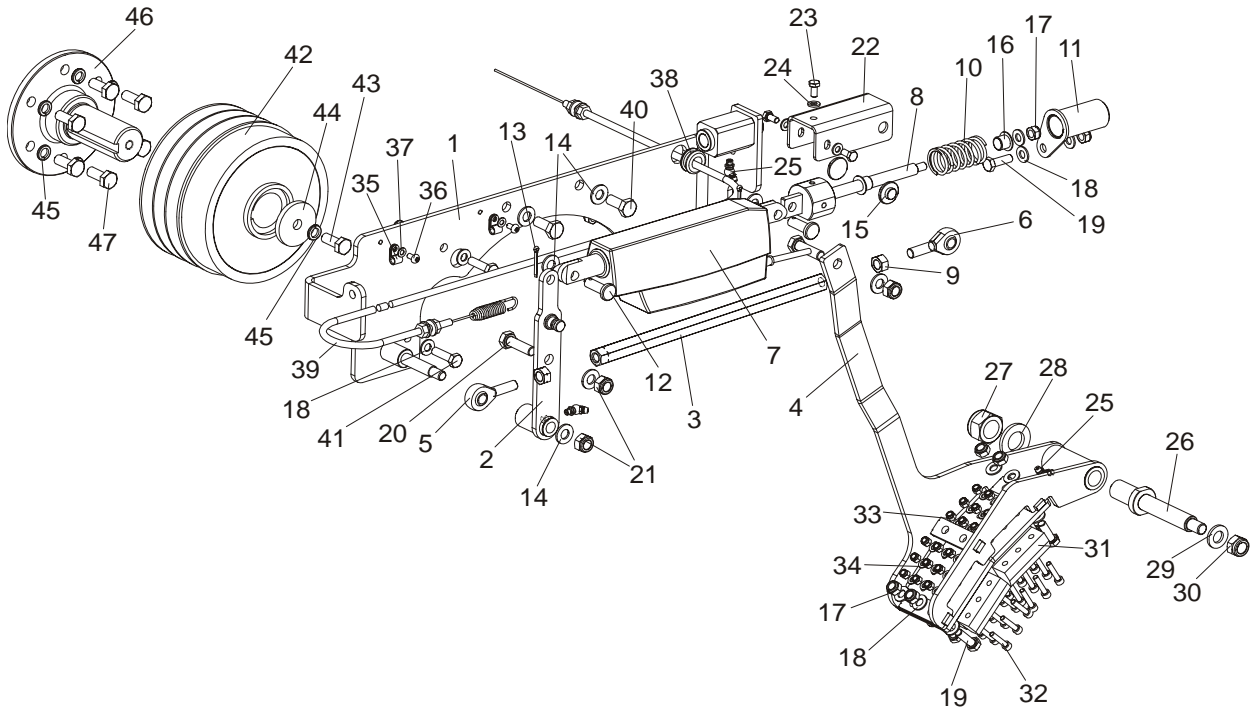

REF	DESCRIPTION (◆ Indicates Parts Available In Assemblies Only)	PART #	QTY.
	ACCELERATION/BRAKE ASSEMBLY, D42	096417	1
1	Bracket, Acceleration/Brake Assy	096434-1	1
2	Lever, ptd	096427-1	1
3	Turnbuckle, M10 zinc	096433-1	1
4	Braking lever, ptd	096419-1	1
5	Turnbuckle End SAL10 CX	096431	1
6	Turnbuckle End SA10	094236	1
7	Actuator, LA121000-20401210 Linear	091309	1
8	Block, Actuator Mount w/Shaft Zinc LA12	091342-1	1
9	Nut, M10-8-B-FE	F81033-3	1
10	Spring, 60X23X3 zinc	088992	1
11	Cover, Actuator Mount Block ptd.	096430-1	1
12	Pin, 10x32x3,2x26-St-A2	F81047-1	2
13	Cotter Pin S-Zn 3,2x25	F81043-4	2
14	Washer, flat, M10,zinc	F81055-1	8
15	Pad, Linear Actuator Slide	089436	2
16	Bushing, XFM-1214-12 flanged	088934	2
17	Nut, M8, Hexagon,Nylon Lock zinc	F81032-2	3
18	Washer, M8, Flat, zinc	F81054-1	5

3

Replacement Parts Acceleration/Brake Assembly

19	Bolt, M8 x 25mm HEX HEAD GR 5.8 ZINC	F81002-5	5	
20	Bolt M10x35-8.8 Fe/Zn5	F81003-17	2	
21	Nut, M10, Nylon Hex zinc lock	F81033-1	3	
22	Spring Cover, ptd	089435-1	1	
23	Bolt, M6x12mm HEX HEAD ZINC	F81001-7	3	
24	Washer, M6, FLAT,ZINC	F81053-1	3	
25	Grease Nipple M6 Type B	094213	2	
26	Rotation Axis, Braking Lever, zinc	096424-1	1	
27	Nut M20, Nylon zinc lock	F81037-2	1	
28	Washer, M20 Flat zinc	F81059-2	1	
29	Washer, M12 , Flat, zinc	F81056-1	1	
30	Nut, M12,Hexagon,Nylon,Zinc,Lock	F81034-2	1	
	Braking assembly	096438	1	
31	Brake Block, narrow	096432	6	
32	Bolt M5x25	F81000-7	18	
33	Nut, M5	F81030-2	18	
34	Washer, M5, Flat zinc	F81052-1	18	
17	Nut, M8,Hexagon,Nylon,Zinc,Lock	F81032-2	4	
18	WASHER, M8, FLAT,ZINC	F81054-1	8	
19	BOLT, M8 x 25mm HEX HEAD GR 5.8 ZINC	F81002-5	5	
35	Cable Mounting EE63	F81080-4	2	
36	Screw H M5x10 8.8 Fe/Zn5	F81000-13	2	
37	Washer, M5, flat zinc	F81052-1	2	
38	Grommet, 20/13 Rubber	086188	1	
39	Cable, Accelerate WM08	089450	1	
40	Bolt M10-1.5x50mm H/H PART/THR G5 ZINC	F81003-29	2	
41	Bolt M8x30	F81002-7	3	
42	Clutch, Type 140-1139 (RADIUS-RADPOL) Centrifugal	089467 097779 ¹	1	
	Clutch Repair Kit, 140-1139 type	084109-1		
	Friction Linings Kit, 140-1139 type	084109	2	
	Spring, Centrifugal Clutch	091649	4	
	Cover, Type 140-1139 Clutch	084109-2	1	
	Ring, AL.60 (440-5049) Retaining	084109-3	1	
43	Bolt M10x25 8.8 PN-M/82105	F81003-31	1	
44	Washer, Blade Drive Wheel	088956-1	1	
45	Washer, M10 Split Nylon,Zinc,Lock	F81055-2	7	
46	Output Shaft, Kubota Engine	088732	1	
47	Bolt M10-1.5x50mm H/H PART/THR G5 ZINC	F81003-29	6	

¹ 097779 Clutch is used for sawmills with low blade speed for hardwood cutting. [See Section 2.8](#)

3.6 Muffler Assembly

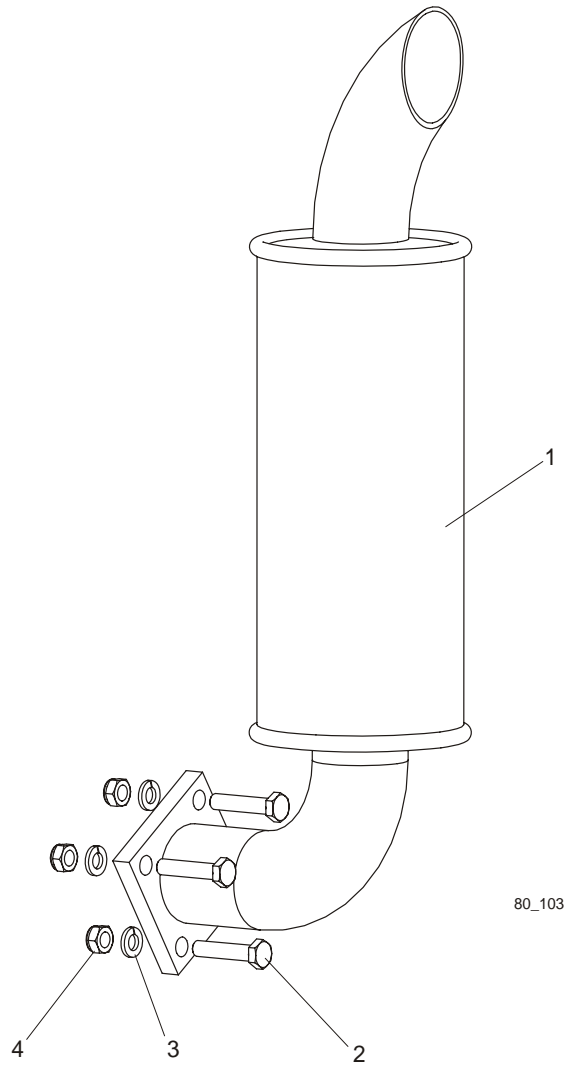

REF	DESCRIPTION (◆ Indicates Parts Available In Assemblies Only)	PART #	QTY.
1	MUFFLER, KUBOTA ENGINE	088100	1
2	BOLT, M8X40-8.8 HEX HEAD FULL THREAD ZINC	F81002-15	4
3	WASHER, 8.2 ZINC SPLIT LOCK	F81054-4	4
4	NUT, M8 HEX WELD	F81032-3	4

3 Replacement Parts

Radiator Assembly

3.7 Radiator Assembly

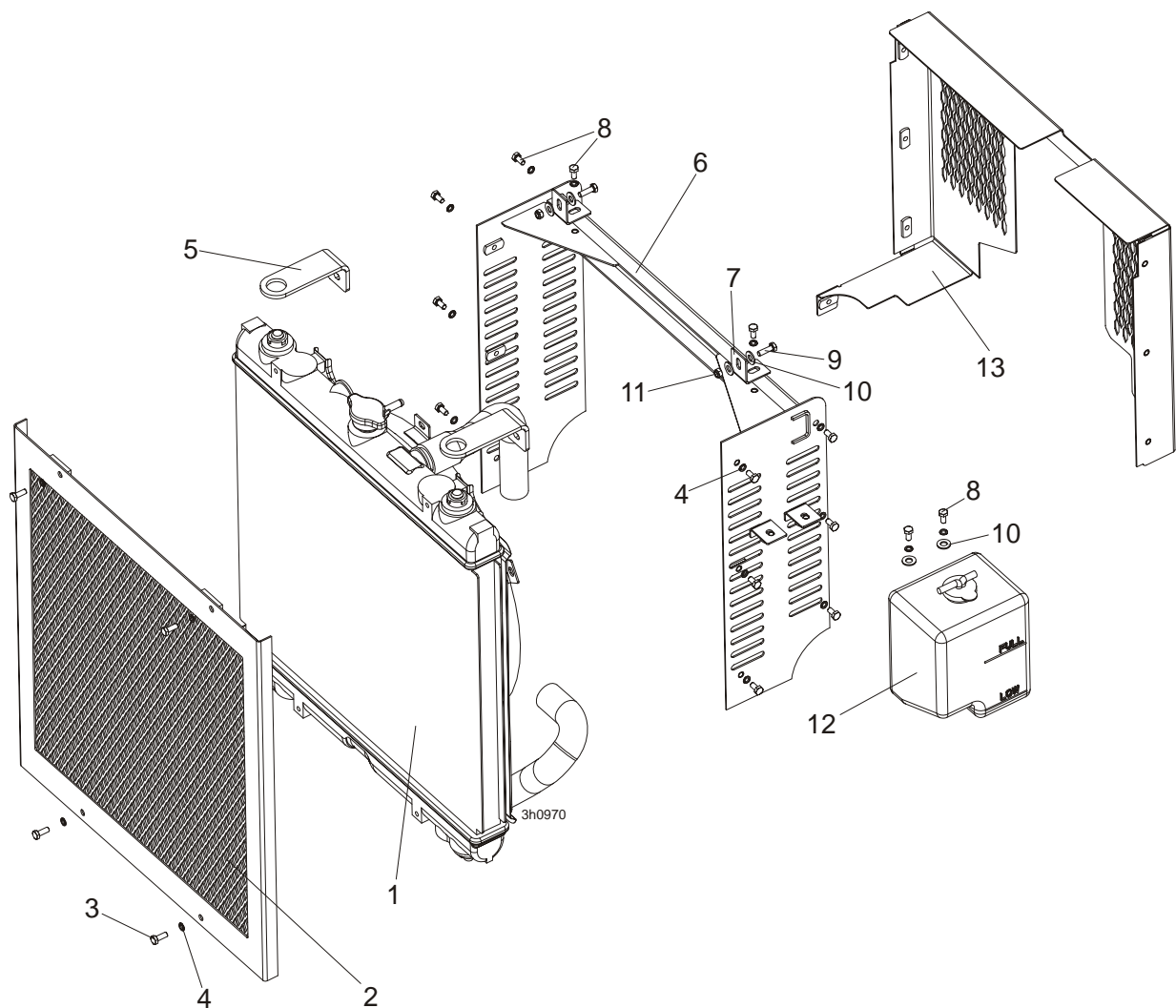

REF	DESCRIPTION (◆ Indicates Parts Available In Assemblies Only)	PART #	QTY.
1	RADIATOR ASSEMBLY, D42	097148	1
2	GUARD, KUBOTA RADIATOR	097201-1	1
3	BOLT M6x16	F81001-15	4
4	WASHER, M6 SPLIT LOCK ZINC	F81053-3	18
5	BRACKET, RADIATOR MOUNT	097305-1	2
6	GUARDS WELDMENT, D42 ENGINE	097156-1	1
7	BRACKET HOLDER	097306-1	2
8	BOLT, M6x12mm HEX HEAD ZINC	F81001-7	16
9	BOLT, M6X20MM, HH, FULL THREAD, ZINC	F81001-2	2
10	WASHER, M8, FLAT,ZINC	F81054-1	6
11	NUT, M6, HEX,NYLON LOCK ZINC	F81031-2	2

Replacement Parts
Radiator Assembly

3

12	RESERVOIR TANK, D42 ENGINE	097157	1	
13	GUARD, RADIATOR INNER	097308-1	1	

3 Replacement Parts

Alternator Assembly

3.8 Alternator Assembly

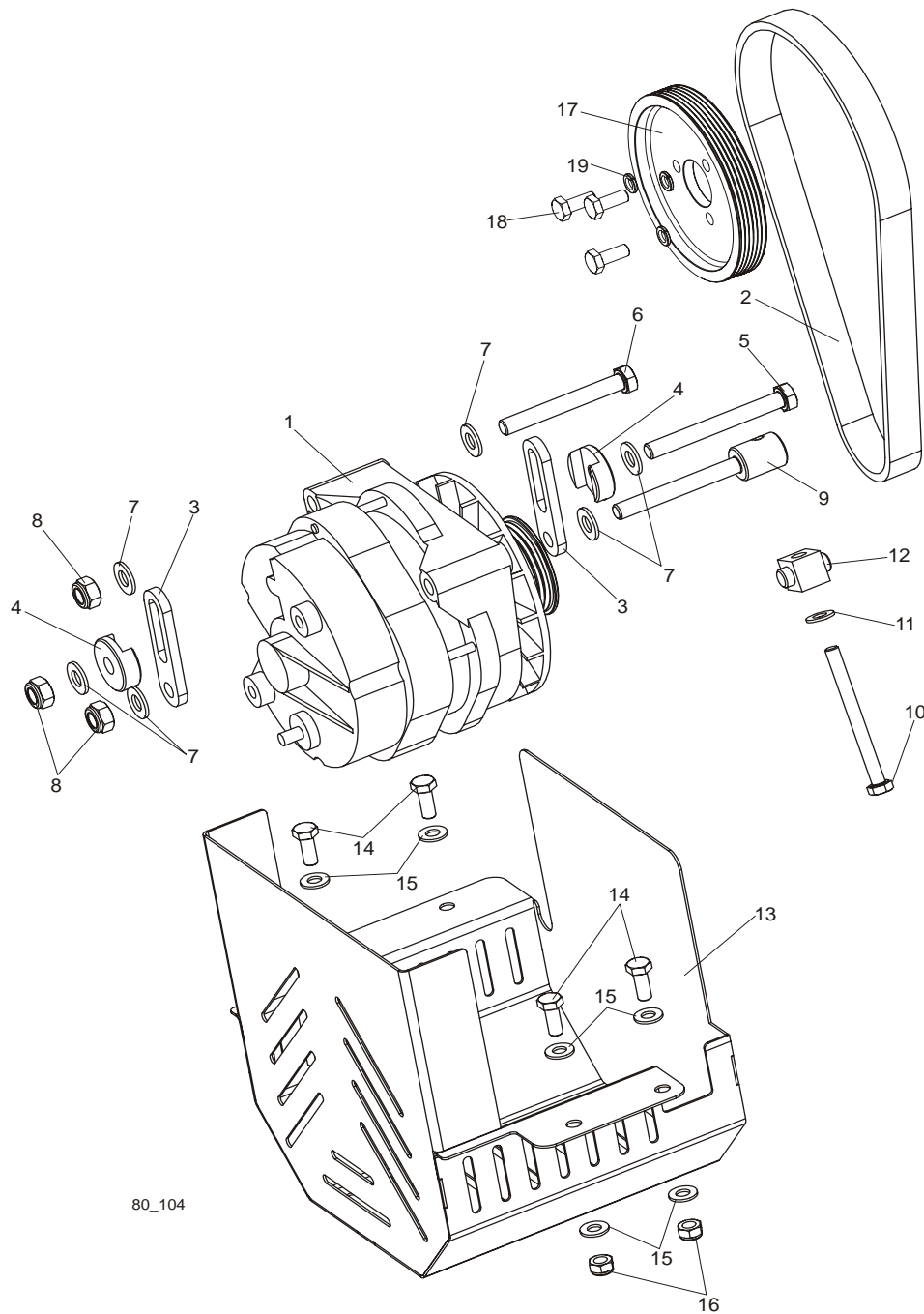

REF	DESCRIPTION (◆ Indicates Parts Available In Assemblies Only)	PART #	QTY.
1	ALTERNATOR, 190A (FOR LT70)	089466	1
2	BELT, 6PK 775 ALTERNATOR	089465	1

3	PLATE, D190 ALTERNATOR BELT TENSIONER	088933-1	2	
4	WASHER, SPECIAL	088932-1	2	
5	BOLT, M10X90-8.8-B HEX HEAD ZINC	F81003-66	1	
6	BOLT, M10X80-8.8 HEX HEAD ZINC	F81003-51	1	
7	WASHER, 10.5 ZINC FLAT	F81055-1	6	
8	NUT, M10-8-B HEX NYLON ZINC LOCK	F81033-1	3	
9	BOLT, M10 SPECIAL	089472-1	1	
10	BOLT, M8X90-8.8 HEX HEAD FULL THREAD ZINC	F81002-16	1	
11	WASHER, 8.4 ZINC FLAT	F81054-1	1	
12	BLOCK, ALTERNATOR BELT TENSIONER	089473-1	1	
13	GUARD, 190A ALTERNATOR	089491-1	1	
14	BOLT, M8X20-8.8-B HEX HEAD FULL THREAD ZINC	F81002-4	4	
15	WASHER, 8.4 ZINC FLAT	F81054-1	8	
16	NUT, M8-8-B HEX NYLON ZINC LOCK	F81032-2	4	
17	PULLEY, ALTERNATOR DRIVE ZINC-PLATED	089458-1	1	
18	BOLT M10-1.5x50mm H/H PART/THR G5 ZINC	F81003-29	3	
19	WASHER, M10 SPLIT LOCK ZINC	F81055-2	3	

3.9 Engine Guards

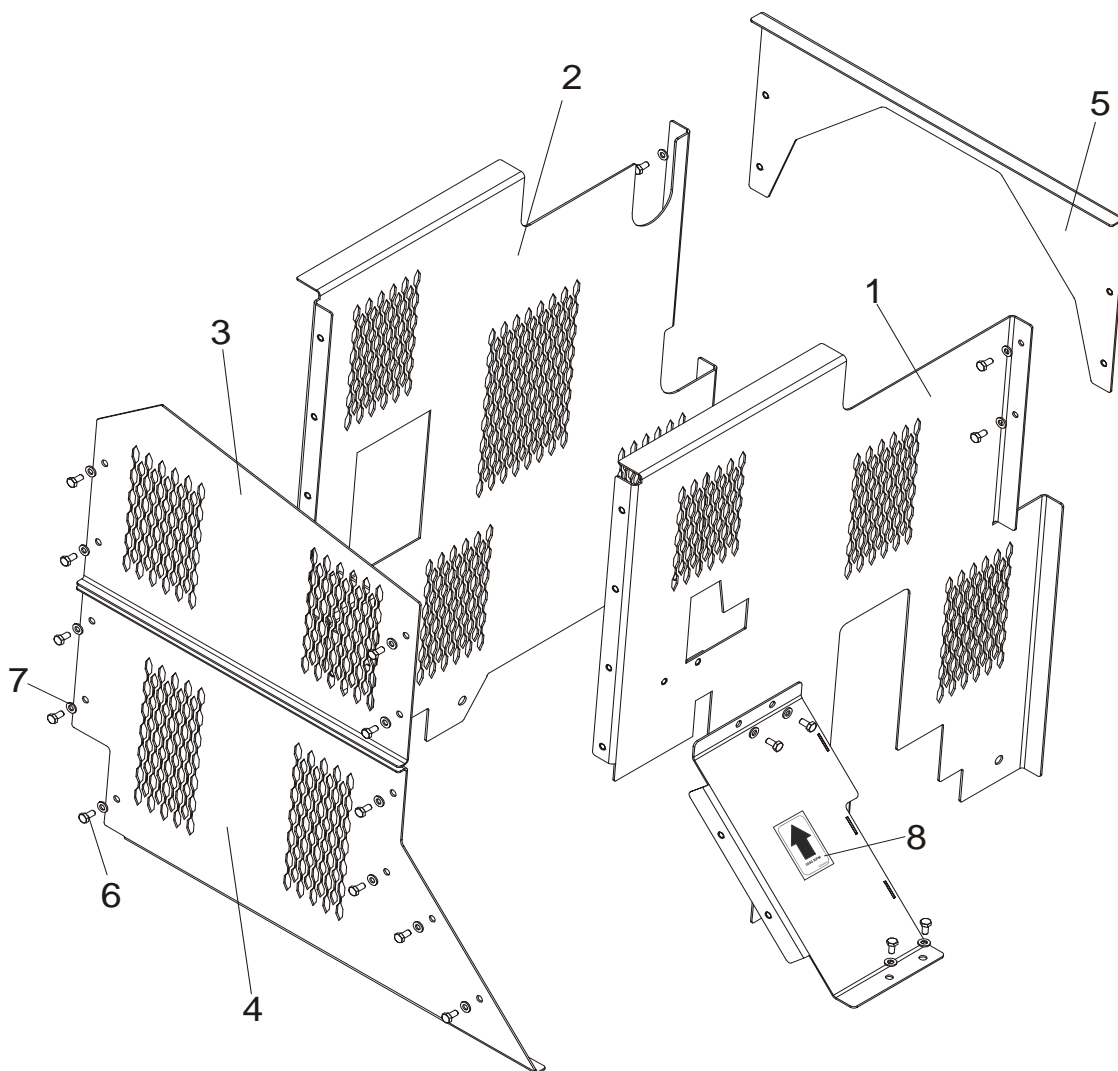

REF	DESCRIPTION (◆ Indicates Parts Available In Assemblies Only)	PART #	QTY.
	D42 ENGINE GUARDS	097596	1
1	Guard Weldment, Left Side Painted	097591-1	1
2	Guard Weldment, Right Side Painted	097593-1	1
3	Guard Weldment, Front Upper Painted	097597-1	1
4	Guard, Front Lower Painted	097598-1	1
5	Guard Weldment, Rear Painted	097600-1	1
6	Bolt, M6x12mm Hex Head Zinc	F81001-7	19
7	Washer, M6, Flat, zinc	F81053-1	19
8	DECAL, 3000 RPM ENGINE DIRECTION	S20097D ¹	1

¹ Includes in 099519 - LT70DC Pictographic Decal Kit..

SECTION 4 ELECTRICAL WIRING DIAGRAMS, D42



IMPORTANT! When using a sawmill with the rewired control panel it is very important not to switch between saw head forward/backward movement until the saw head stops. Failure to do so may result in serious sawmill damage.



WARNING! When using the variable reverse speed wiring it is recommended that the operator should stop the head, turn the potentiometer to zero, engage reverse and then increase speed. Failure to do this may result in damage to the circuit. There is a protection in the circuit and if this is activated it will not allow the head to start the return movement until the potentiometer is set to zero.

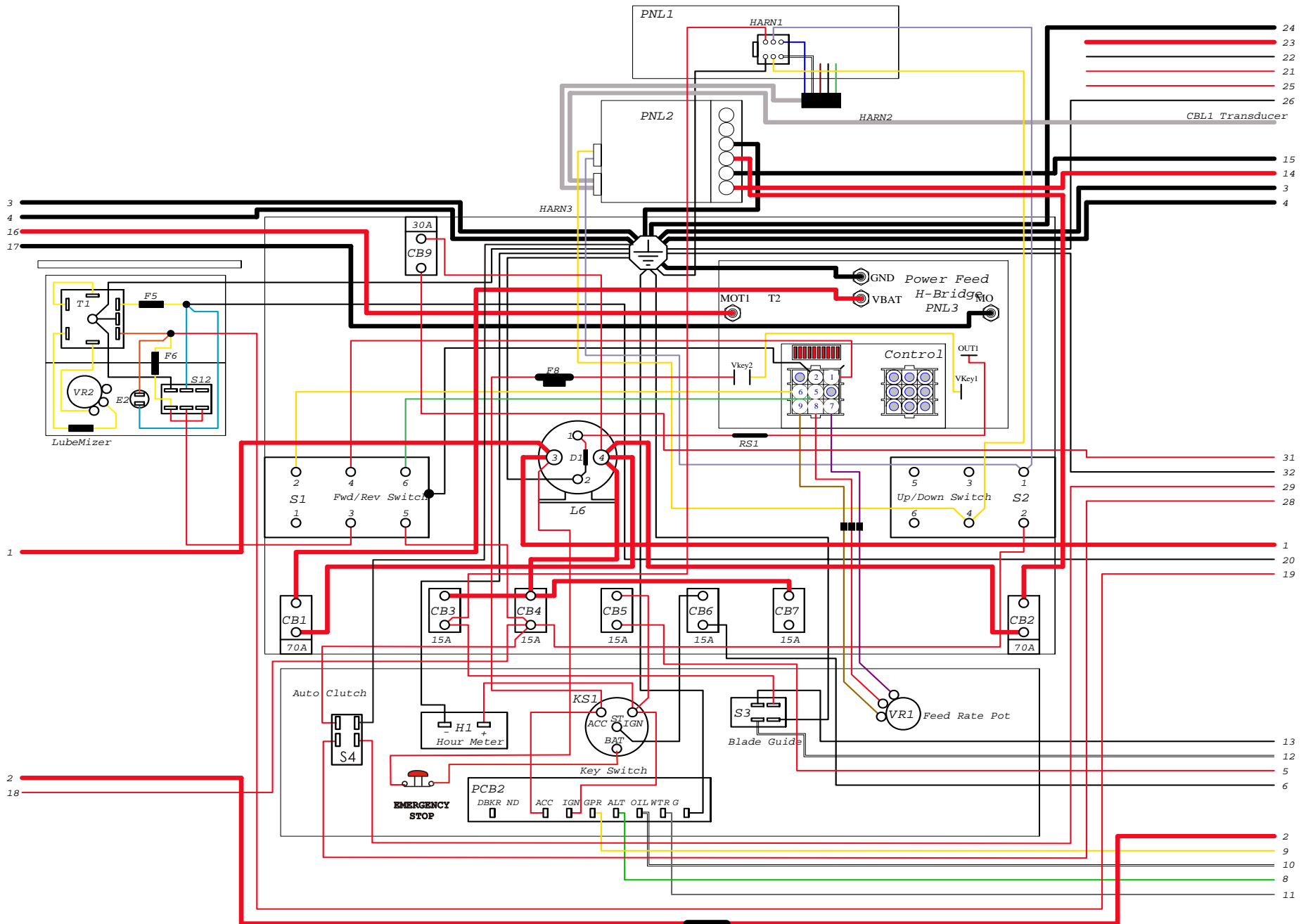

FIG. 4-1 D42 CONTROL BOX DIAGRAM.

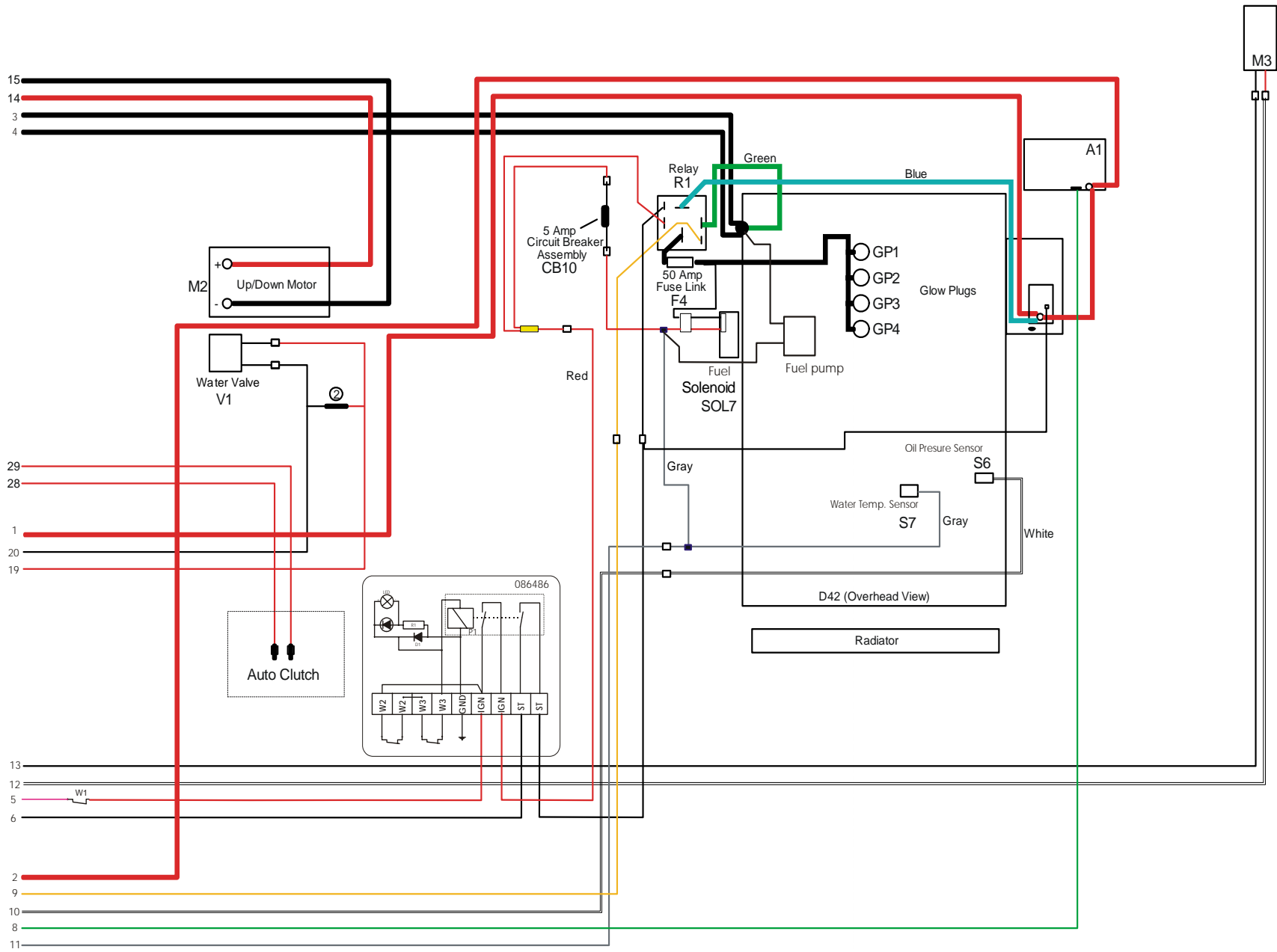

FIG. 4-4 D42 WIRING DIAGRAM.

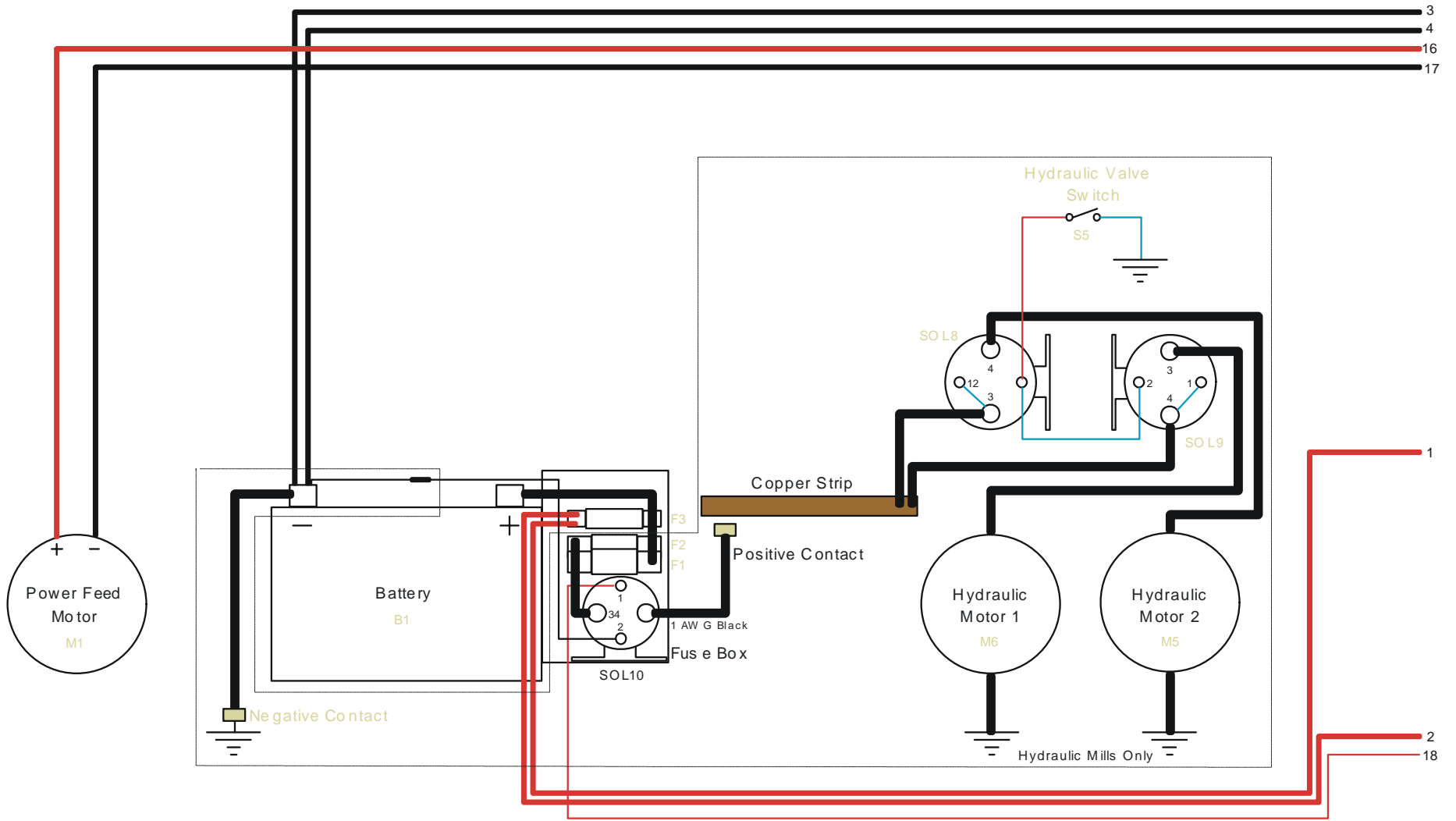

FIG. 4-5 D42 HYDRAULIC DIAGRAM.

Component List

Item	Mfg. Part No.	Mfg.	Wood-Mizer Part No.	Description
	023 73 0	Wood-Mizer	023 73 0	Alternator, 140 Amp
B1	1231 PMF	Deka	015475	Battery, 12 Volt (See Battery Specifications)
CB1	70-164 8-009	Mech. Prod.	015 52 7	Breaker, 70 Amp Manual Reset Panel Mount, Power Feed
CB2	70-164 8-009	Mech. Prod.	015527	Breaker, 70 Amp Manual Reset Panel Mount, Up/Down
CB3	CH 304 07-15	Cole-Hersee	E204 30	Breaker, 15 Amp Manual Reset, Blade Guide
CB4	CH 304 07-15	Cole-Hersee	E204 30	Breaker, 15 Amp Manual Reset, Accessory
CB5	CH 304 07-15	Cole-Hersee	E204 30	Breaker, 15 Amp Manual Reset, Ignition
CB6	CH 304 07-15	Cole-Hersee	E204 30	Breaker, 15 Amp Manual Reset, Start
CB7	CH 304 07-15	Cole-Hersee	E204 30	Breaker, 15 Amp Manual Reset, Board Return
CB1 0	024 45 3	Wood-Mizer	024 45 3	Breaker Assy, Water Temp Max Circuit
D1 -D5	087496	Wood-Mizer	087496	Diode Assembly, Solenoid Coil Chassis
D7	024 12 3	Wood-Mizer	024 12 3	Diode Assembly, Inductive Kick Protection (Setworks Only)
F1 , F2 ¹	RL-225	Gould	P 11 55 0	Fuse Link, 225 Amp, 250 Volt For Hydraulic + 12 Volt Circuit
F3	RL-150	Gould	023361	Fuse Link, 150A 25 0V For Main + 12 Volt Starter, Alternator
F4	N/A	N/A	02 45 97	Fuse Link, 50 Amp Kubota Glow Plug
GP1-GP4	16851-65510	Kubota	092277	Glow Plug
H1	T14BH517BC9	ENM Corp.	015 40 1	Hour Meter, 12 Volt, Low Power T14 Series
KS1	121801	General	P04350	Key Switch, 4-position (Accessory, Off, Ignition, Start)
M1	10 86 77 .00	Leeson	024169	Motor, 3/4HP 12VDC TEFC Power Feed w/o Base
M2	1086 78.00	Leeson	015174	Motor, 3/4HP 12VDC TEFC Up/Down w/Base
M3	P096 98-1	Klauber	A10 36 5	Motor, 12 Volt Blade Guide Arm 53:1 Gear
M4	P096 98-1	Klauber	A10 36 5	Motor, 12 Volt Board Return 53:1 Gear
M5, M6 ¹	81 11	Mona rch	P09955	Motor, 12 Volt Hydraulic Pump
PCB1	051667	Wood-Mizer	051667	Circuit Board, Control Box Power Feed
PCB2	089694	Wood-Mizer	089694	Board, LED Circuit (Diesel)
R1	1238 537	Bosch	092277	Relay, Glow Plug Timer
S1	2601-AF 2-S11	Sq u are D	E20438	Drum Swi tch, Power Feed Fwd/Reverse Motor
S2	26 01 -AF2-S12	Square D	E20 44 0	Drum Switch, Up/Down Motor
S3	34-5910	Pollak	024 20 0	Toggle Switch, Blad e Guide In/Out Motor
S4	34-5910	Pollak	02 42 00	Toggle Switch, Board Return Motor
SS ¹	024 19 8	Wood-Mizer	024198	Switch, Hydraulic Pump Levers
S6	15841-39010	Kubota	028 54 7	Switch, Oil Pressure Sensor
S7	TM9A230ROCG	Kubota	028 51 0	Switch, Water Temp Sensor
SOL1	015470	Stancor	015470	Solenoid 200 A 12V SPST
SOL4 -SOL 5	586-911	Stancor	015417	Solenoid, 200 A 12V DPST
SOL7	17454-60010	Kubota	028 52 3	Solenoid, Fuel
SOL8, SOL9, SOL10 ¹	586-902	Stancor	015470	Solenoid, 200 A 12V SPST Hydraulic Pump Motor
V1	G51190 145	Parker	016280	Valve , Waterlube Solenoid
VR1	E20519	Wood-Mizer	E20519	Potentiometer, Variable Resistance Power Feed