

## user manual

Instrukcja obsługi | Руководство пользователя  
Manuel de l'Utilisateur | Betriebsanweisung  
Bruksanvisning | Manual del Usuario  
Betjeningsvejledning | Gebruikershandleiding  
Käyttöohjeet | Manual de utilizare | Bruksanvisning  
Manuale d'uso | Příručka uživatele

Zachować do przyszłego użytku  
Сохраните для последующего использования  
A conserver pour une utilisation future  
Für zukünftige Benutzung aufbewahren  
Behold for senere bruk  
Säilytä nämä käyttöohjeet tulevaa tarvetta marten  
Opbevar manualen til fremtidig brug  
Bewaren voor gebruik in de toekomst  
Conservare il presente manuale a l'uso futuro  
Păstrați acest manual pentru utilizare viitoare  
Conservar para futuras consultas  
Uchovajte pro další použití



# Edger Multi-Rip

## Safety, Operation, Maintenance & Parts Manual

---

<b>EG300E20S-EMR</b>	<b>rev. A2.02</b>
<b>(EE20S-EMR)</b>	<b>rev. A2.02</b>
<b>EG300E25S-EMR</b>	<b>rev. A2.02</b>
<b>(EE25S-EMR)</b>	<b>rev. A2.02</b>

---



**Safety is our #1 concern!** Read and understand all safety information and instructions before operating, setting up or maintaining this machine.

*June 2009*

*Form #907*

# Table of Contents

# Section-Page

<b>SECTION 1</b>	<b>SERVICING THE EDGER</b>	<b>1-1</b>
1.1	If You Need To Order Parts .....	1-1
1.2	Customer and Edger Identification.....	1-1
1.3	If You Need Service .....	1-2
1.4	Edger Components .....	1-2
<b>SECTION 2</b>	<b>SAFETY</b>	<b>2-1</b>
2.1	Safety Symbols.....	2-1
2.2	Safety Instructions.....	2-1
<b>SECTION 3</b>	<b>OPERATION</b>	<b>3-1</b>
3.1	Pre-Operation Check .....	3-1
3.2	Control Overview .....	3-3
3.3	Edger Setup .....	3-4
3.4	Machine Start.....	3-6
3.5	Blade Installation.....	3-8
3.6	Edging Lumber.....	3-13
<b>SECTION 4</b>	<b>SETWORKS OPERATION</b>	<b>4-1</b>
4.1	Edger Controller Panel .....	4-1
4.2	Start-up settings of the controller .....	4-2
4.3	Operation, Memory Buttons (A, B, C, D, E).....	4-5
<b>SECTION 5</b>	<b>MAINTENANCE &amp; ALIGNMENT</b>	<b>5-1</b>
5.1	Changing the Blades.....	5-1
5.2	Tensioning the Belts .....	5-3
5.3	Tensioning the Chains .....	5-4
5.4	Checking the Rollers .....	5-6
5.5	Lubrication .....	5-6
5.6	Maintaining and Sharpening Anti-Kickback Fingers.....	5-7
5.7	Alignment.....	5-7
5.8	Blade Sharpening.....	5-10
5.9	Using the Blades.....	5-11
<b>SECTION 6</b>	<b>SPECIFICATIONS</b>	<b>6-1</b>
6.1	Overall Dimensions .....	6-1
6.2	Multirip Edger Specifications.....	6-2
6.3	Electrical Diagram EG300EB_S .....	6-3
6.4	Electrical Diagram EG300EC .....	6-5
6.5	Electrical Diagram EG300EH .....	6-7
6.6	Electrical Diagram EG300EH_S .....	6-9

## Table of Contents

## Section-Page

6.7	Electrical Component List EG300EB_S .....	6-11
6.8	Electrical Component List EG300EC .....	6-12
6.9	Electrical Component List EG300EH_S .....	6-13
6.10	Dust Extractor Specifications .....	6-14

### **SECTION 7 PARTS**

**7-1**

7.1	How To Use The Parts List .....	7-1
7.1	Sample Assembly .....	7-1
7.2	Anti-Kickback Assembly & Press Roller.....	7-2
7.3	Blades Drive Shaft Assembly.....	7-4
7.4	Spacer Mounting Kit (Optional).....	7-6
7.5	Covers.....	7-7
7.6	Infeed Roller Assemblies & Roller Chains .....	7-9
7.7	Board Guide Fence .....	7-10
7.8	Motor Assembly, Control Box, Electric Box, Safety Switches .....	7-11
7.9	Blade Setting Assembly .....	7-13
7.10	Laser Guide Assembly (Optional).....	7-15
7.11	Control Box .....	7-17
7.12	Table .....	7-19
7.13	Sawdust Hopper.....	7-21
7.14	Edger Decals.....	7-22

### **SECTION 8 DC ELECTROMAGNETIC BRAKE**

**8-1**

8.1	Design and Principle of Operation .....	8-1
8.2	Service .....	8-2

## SECTION 1 SERVICING THE EDGER

Wood-Mizer is committed to providing you with the latest technology, best quality and strongest customer service available on the market today. We continually evaluate our customers' needs to ensure we're meeting current wood-processing demands. Your comments and suggestions are welcome.

### 1.1 If You Need To Order Parts

From Europe call our European Headquarters and Manufacturing Facility in Kolo, ul. Nagórna 114, Poland at **+48-63-2626000**. Please have the machine identification number and your customer number ready when you call. Wood-Mizer will accept these methods of payment:

- Visa, Mastercard, or Discover
- COD
- Prepayment
- Net 15 (with approved credit)

Be aware that shipping and handling charges may apply. Handling charges are based on size and quantity of order. In most cases, items will ship on the day they are ordered. Second Day and Next Day shipping are available at additional cost.

### 1.2 Customer and Edger Identification

Each Wood-Mizer edger has a serial number. In addition, when you pick up your edger, you will receive a customer number. These three numbers will help expedite our service to you. Please locate them now and write them below so you have quick, easy access to them.

**See Figure 1-1.** See the following figures for serial number locations.

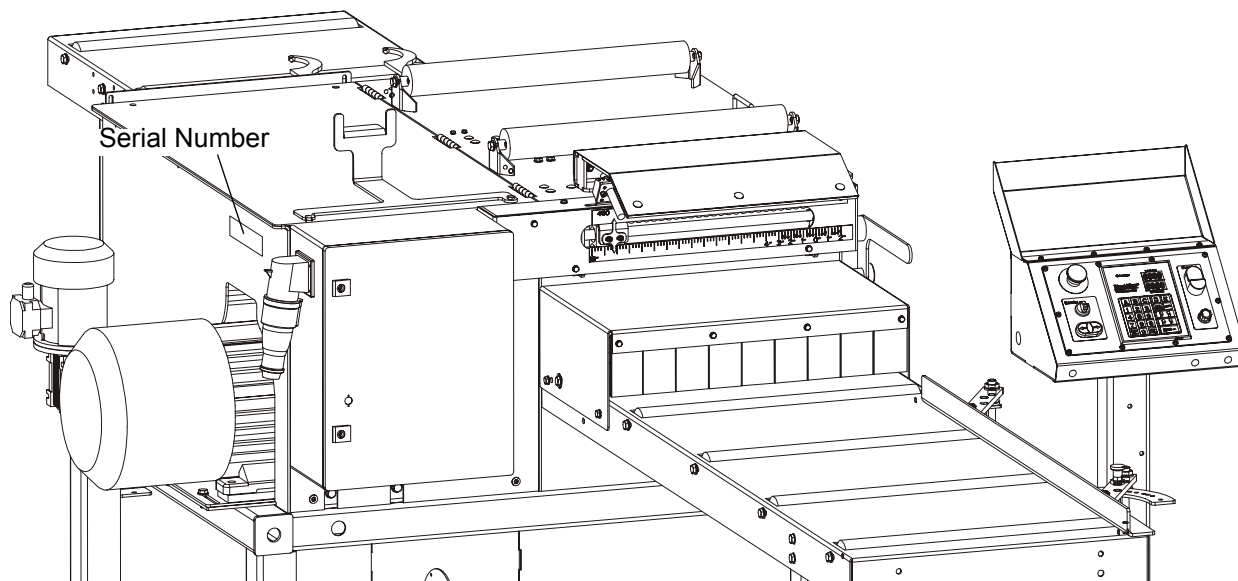

**FIG. 1-1**

### 1.3 If You Need Service

From Europe call our European Headquarters and Manufacturing Facility in Kolo, Nagórna 114, Poland at **+48-63-2626000**. Ask to speak with a Customer Service Representative, please have your machine identification number and your customer number ready when you call. The Service Representative can help you with questions about the operation and maintenance of your edger. He also can schedule you for a service call.

**Office Hours:**

Country	Monday - Friday	Saturday	Sunday
Poland	7-16	Closed	Closed

### 1.4 Edger Components

See Figure 1-2. The major components of the Edger are shown below.

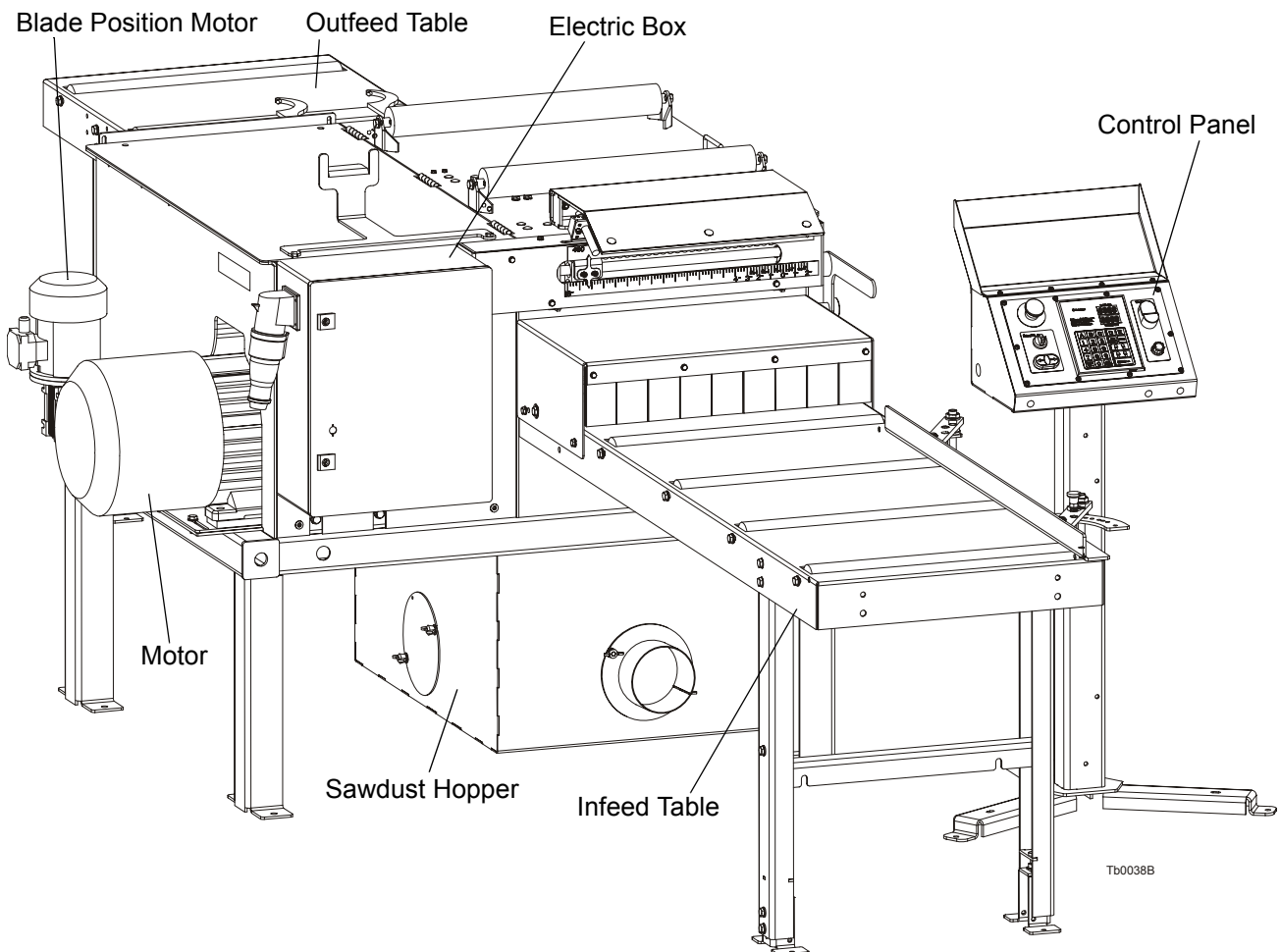



**FIG. 1-2**

## SECTION 2 SAFETY

### 2.1 Safety Symbols

The following symbols and signal words call your attention to instructions concerning your personal safety. Be sure to observe and follow these instructions.

 **DANGER!** indicates an imminently hazardous situation which, if not avoided, will result in death or serious injury.

 **WARNING!** suggests a potentially hazardous situation which, if not avoided, could result in death or serious injury.

 **CAUTION!** refers to potentially hazardous situations which, if not avoided, may result in minor or moderate injury or damage to equipment.

 **IMPORTANT!** indicates vital information.

**NOTE:** gives helpful information.

 Warning stripes are placed on areas where a single decal would be insufficient. To avoid serious injury, keep out of the path of any equipment marked with warning stripes.

### 2.2 Safety Instructions

**NOTE:** ONLY safety instructions regarding personal injury are listed in this section. Caution statements regarding only equipment damage appear where applicable throughout the manual.

#### *Observe Safety Instructions*

 **IMPORTANT!** Read the entire Operator's Manual before operating the Edger. Take notice of all safety warnings throughout this manual and those posted on the machine. Keep this manual with this machine at all times, regardless of ownership.

Also read any additional manufacturer's manuals and observe any applicable safety instructions including dangers, warnings, and cautions.



Only persons who have read and understood the entire operator's manual should operate the Egder. The Egder is not intended for use by or around children.

**IMPORTANT!** It is always the owner's responsibility to comply with all applicable federal, state and local laws, rules and regulations regarding the ownership and operation of your Wood-Mizer Edger. All Wood-Mizer owners are encouraged to become thoroughly familiar with these applicable laws and comply with them fully while using the Egder.



### **Wear Safety Clothing**



**WARNING!** Secure all loose clothing and jewelry before operating the machine. Failure to do so may result in serious injury or death.

**WARNING!** Always wear gloves and eye protection when handling bandsaw blades. Changing blades is safest when done by one person! Keep all other persons away from area when coiling, carrying or changing a blade. Failure to do so may result in serious injury.

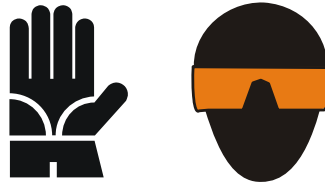

**WARNING!** Always wear eye, ear, respiration, and foot protection when operating or servicing the Egder.



### Keep Egder And Area Around Clean

 **DANGER!** Maintain a clean and clear path for all necessary movement around the Egder and lumber stacking areas. Failure to do so will result in serious injury.

### Dispose Of Sawing By-Products Properly

 **IMPORTANT!** Always properly dispose of all sawing by-products, including sawdust and other debris.

### Check Edger Before Operation

 **DANGER!** Make sure all guards and covers are in place and secured before operating the Egder. Failure to do so may result in serious injury.



 **WARNING!** Always shut off the motor to stop the blade whenever the Edger is not in use. Failure to do so may result in serious injury.

**WARNING!** Do not for any reason adjust the motor drive belts with the motor running. Doing so may result in serious injury.

**WARNING!** Always ensure that there is a sharp point on the anti-kickback fingers before each use of the Edger.

Be sure anti-kickback fingers are free from obstruction and are in a downward position with lever released. Failure to do so may result in serious injury.

### Keep Persons Away

 **DANGER!** Keep all persons out of the path of moving equipment and boards when operating the Edger. Failure to do so will result in serious injury.

## Keep Hands Away



**DANGER!** Motor components can become very hot during operation. Avoid contact with any part of a hot motor. Contact with hot motor components can cause serious burns. Therefore, never touch or perform service functions on a hot motor. Allow the motor to cool sufficiently before beginning any service function.

**DANGER!** Moving Parts Can Crush and Cut. Keep hands clear. Make sure all guards and covers are in place and secured before operating or towing. Failure to do so may result in serious injury.

**DANGER!** Always be aware of and take proper protective measures against rotating shafts, pulleys, fans, etc. Always stay a safe distance from rotating members and make sure that loose clothing or long hair does not engage rotating members resulting in possible injury.

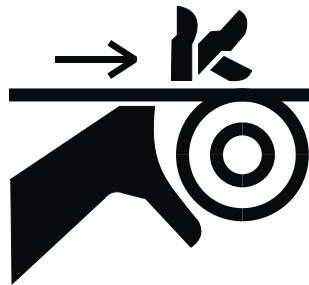

**WARNING!** Coastdown Required. Always shut off the motor and allow all moving parts to come to a complete stop before removing any guards or covers. Do NOT operate with any guards or covers removed.

**WARNING!** Kickback Hazard. Stay clear of area during operation. Follow all anti-kickback service and safety rules. Failure to do so may result in serious injury

**DANGER!** Before changing the blades or performing any service to the machine, disconnect the power cord from the electric box.

**IMPORTANT!** The blade housing and drive assembly covers are equipped with safety key switches. As soon as you open the cover, the motor will get turned off and all moving parts will stop spinning. The safety switches should always be in proper working condition.

**IMPORTANT!** The cutting width system is equipped with safety switch. When you feed a board into edger, the cutting width setting is blocked.



### Use Proper Maintenance Procedures



**DANGER!** Make sure all electrical installation, service and/or maintenance work is performed by a qualified electrician and is in accordance with applicable electrical codes.

**DANGER!** Hazardous voltage inside the electric boxes and at the motor can cause shock, burns, or death. Disconnect and lock out power supply before servicing! Keep all electrical component covers closed and securely fastened during machine operation.



**WARNING!** Consider all electrical circuits energized and dangerous.

**WARNING!** Disconnect and lock out power supply before servicing! Failure to do so may result in serious injury.

**WARNING!** Never assume or take the word of another person that the power is off; check it out and lock it out.

**WARNING!** Do not wear rings, watches, or other jewelry while working around an open electrical circuit.



**IMPORTANT!** Edger is equipped with two emergency stop buttons - one at the front, the other at the rear of the machine. They are used to immediately stop the motor and/or Edger operation in hazardous situations. The emergency stop buttons should always be in proper condition.

### Keep Safety Labels In Good Condition



**IMPORTANT!** Always be sure that all safety decals are clean and readable. Replace all damaged safety decals to prevent personal injury or damage to the equipment. Contact your local distributor, or call your Customer Service Representative to order more decals.

**IMPORTANT!** If replacing a component which has a safety decal affixed to it, make sure the new component also has the safety decal affixed.

### Fire-Fighting

**CAUTION!** The edger's work-stand should be equipped with a 4 kg or bigger dry powder extinguisher.





### Safety Labels Description

See Table 2-1. See table below for safety labels description.



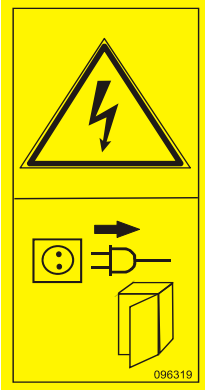



**TABELA 2-1**

Decals View	Decal No.	Description
	099220	Close guards prior to operating the machine
	096316	Electric box opening is possible with the switch in "0" position only.

**TABELA 2-1**

	<p>096319</p>	<p>Always disconnect the power cord before opening the electric box.</p>
	<p>099540</p>	<p>CAUTION! Gear train - Keep safe distance!</p>
	<p>S12004G</p>	<p>Always wear eye protection equipment when operating this machine.</p>
	<p>S12005G</p>	<p>Always wear ear protection equipment when operating this machine.</p>

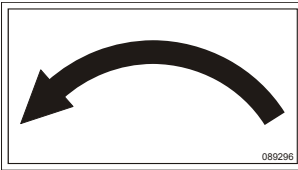
**TABELA 2-1**

	<p>501465</p>	<p>Always wear safety boots when operating this machine.</p>
	<p>501467</p>	<p>Lubrication point</p>
	<p>099504</p>	<p>Visible and/or invisible laser radiation. Avoid eye or skin exposure to direct or scattered radiation.</p>
	<p>P85070</p>	<p>CE certified machine</p>
	<p>089296</p>	<p>Rotation direction</p>
	<p>S20097</p>	<p>Motor rotation direction</p>

## SECTION 3 OPERATION

### 3.1 Pre-Operation Check

Prior to operating the Edger; always perform these basic checks:

1. Make sure the Edger is level. Secure the legs to the surface.

 **CAUTION!** Always be sure the machine is level prior to operating. Failure to do so can and will affect machine operation and wear life.

2. Make sure the outfeed table is level with the rest of the Edger. Place blocks under the table if necessary.
3. Make sure the motor drive belt is tensioned properly.

 **WARNING!** Do not for any reason adjust the motor drive belts with the motor running. Doing so may result in serious injury.

4. Be sure the anti-kickback fingers are in proper working condition.

 **WARNING!** Always ensure that there is a sharp point on the anti-kickback fingers before each use of the Edger.

Be sure anti-kickback fingers are free from obstruction and are in a downward position with lever released. Failure to do so may result in serious injury.

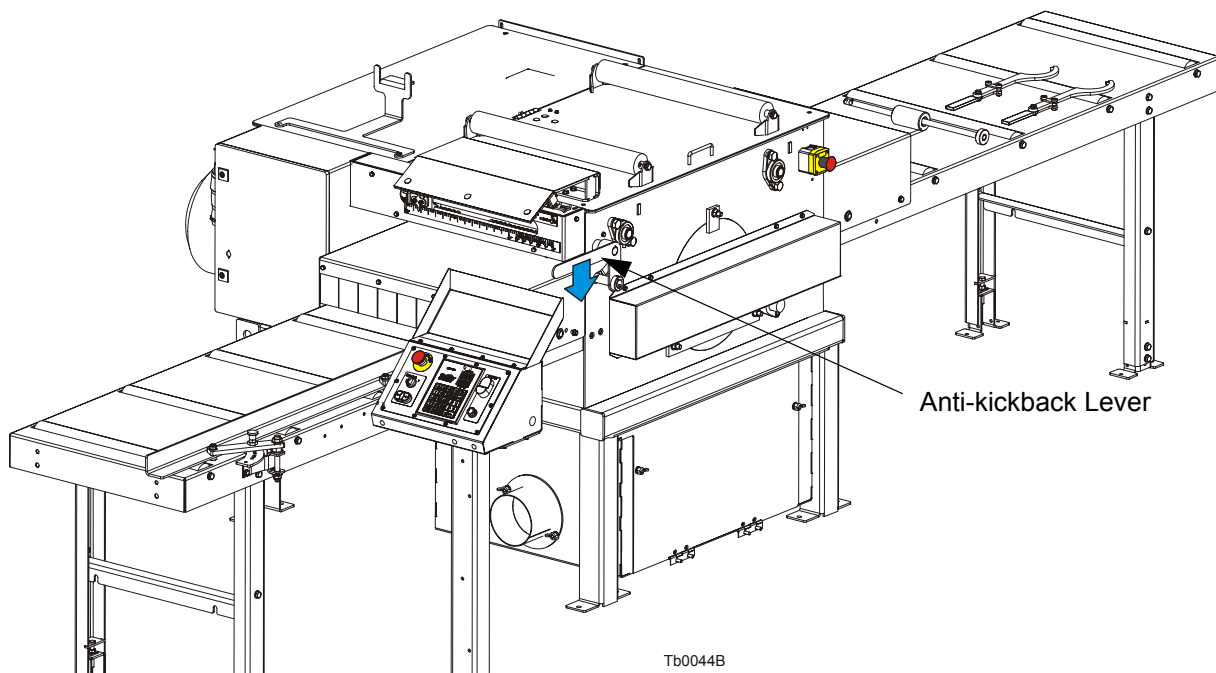



FIG. 3-0



5. Be sure all guards and covers are in place and secured.

 **DANGER!** Make sure all guards and covers are in place and secured before operating or towing the Edger. Failure to do so may result in serious injury.

6. Also be aware that the blades are spinning whenever the motor is ON. You should always turn off the motor to stop the blade whenever the Edger is not in use and ensure that all parts have stopped moving before removing any covers or guards.

 **WARNING!** Coastdown Required. Always shut off the motor and allow all moving parts to come to a complete stop before removing any guards or covers. Do NOT operate with any guards or covers removed.

**WARNING!** Always shut off the motor to stop the blade whenever the Edger is not in use. Failure to do so may result in serious injury.

 **IMPORTANT!** If at any time you need to immediately stop the motor and/or Edger operation, press the Emergency Stop button located at the front or at the rear of the Edger.

Emergency Stop  
Twist to release

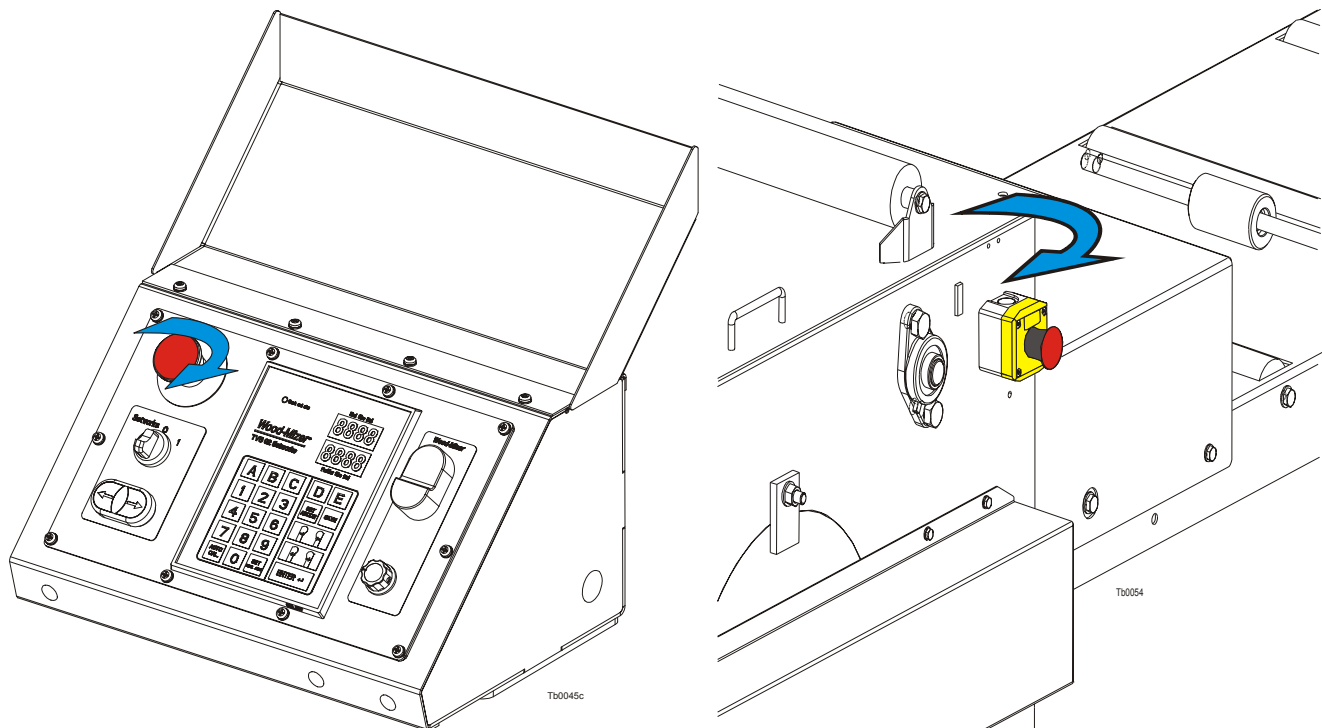
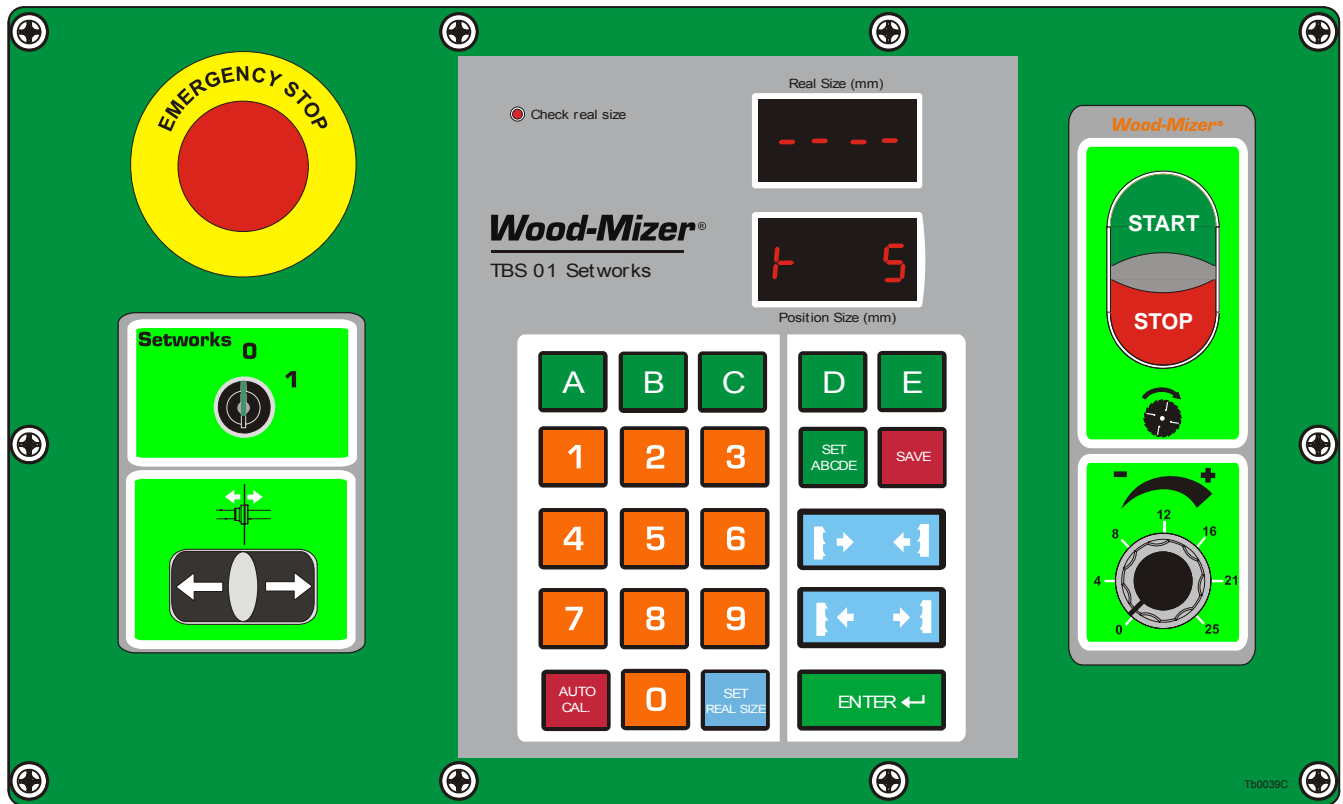

**FIG. 3-0**

### 3.2 Control Overview

#### 1. Control Panel

See **Figure 3-1**. The control panel includes: START-STOP switch, blade distance automatic controller, feed rate knob, automatic controller ON/OFF switch, additional switches for setting blades distance and emergency stop button.



**FIG. 3-1 CONTROL PANEL COMPONENTS**

#### 2. Blade Drive



To start the blade motor press the START button. To stop the blade motor, press the STOP button.

#### Feed Roller Speed Adjustment



The feed roller speed switch controls the speed at which the feed roller moves. Turn the switch right to increase the speed, turn left to reduce the speed.

#### 4. Edger Setworks Controller

Allows to set blade position automatically. [See Section SECTION 3 SETWORKS OPERATION \(Optional Equipment\)](#)

## 5. Emergency Stop

Push the emergency stop button to stop the blade and the track feed motors. Turn the emergency stop clockwise to release the stop. The machine will not restart until the emergency stop is released.

## 3.3 Edger Setup

 **IMPORTANT!** Before starting to use the Edger you have to meet the following conditions:

- Set up the machine on firm and level ground
- The machine should be operated with the sawdust collection system
- The machine can be operated under roof only
- The machine can be operated in temperature range from -15° C to 40° C only
- Light intensity at operators position must be 300lx
- The machine operator's position is shown below

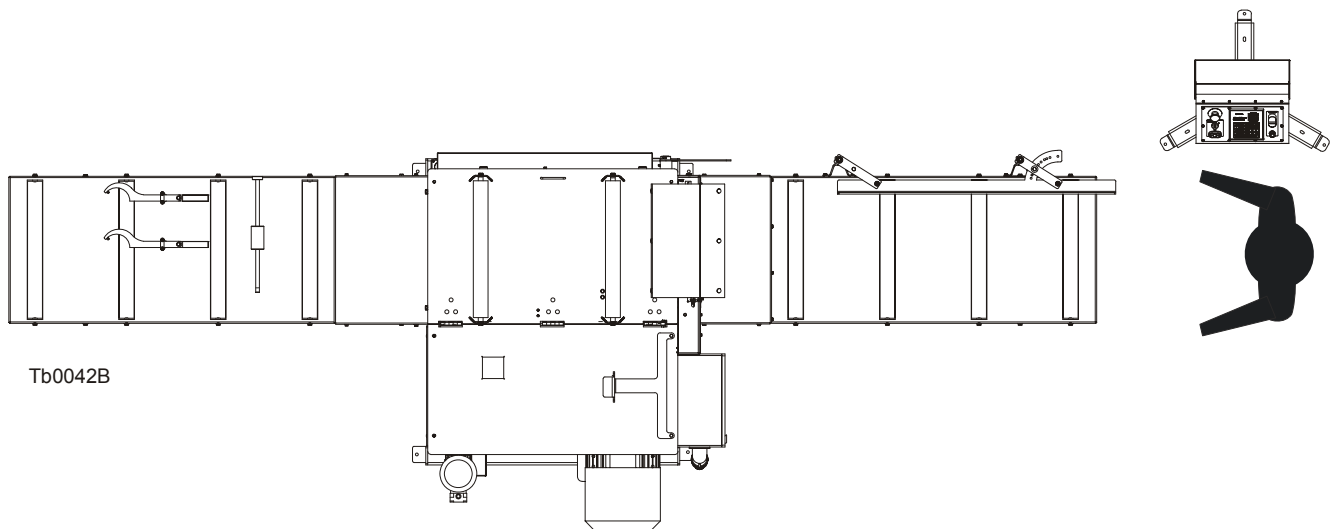



**FIG. 3-1**

- Have a qualified electrician install the power supply (according to EN 60204 Standard). The power supply must meet the specifications given in the table below.

3-Phase Volts	Fuse Disconnect	Suggested Wire Size
400 VAC	40 Amps	4 mm <sup>2</sup> , up to 15 m long

**TABLE 3-1**

 **IMPORTANT!** When starting the machine for the first time, check that blade rotation direction is as indicated by the arrow located on the blades covers. If the rotation direction is incorrect, invert the phases in the phase inverter located in the power socket (electric box). Setting the phases in the phase inverter correctly will ensure correct rotation directions of all machine motors.

 **IMPORTANT!** When starting the machine for the first time, let it run without any load for 1-2 hours. It will let the infeed and outfeed tables drive components to grind in.

- The Edger can be lifted using the forklift only. Forklift must be rated for at least 2000kg. Edger is equipped with forklift pockets. Remove sawdust hopper before lifting the Edger by forklift. Insert the forks into the pockets shown on the picture below.

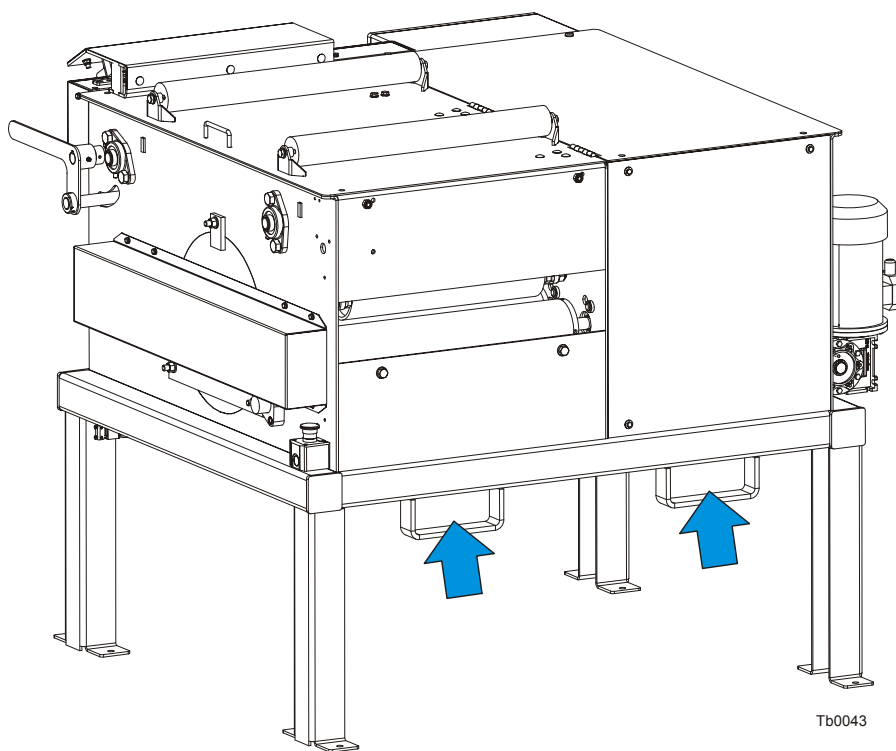

**FIG. 3-1**

### 3.4 Machine Start

 **DANGER!** Before starting the machine, perform these steps to avoid injury and/or damage to the equipment:

- Close the blade housing covers and replace any guards removed for service.
- Check the feed rollers and remove all loose objects such as tools, wood, etc.
- Make sure all persons are a safe distance from the machine.
- Check that the emergency stops are released.

**NOTE:** The machine will not start if either of the emergency stops is on.

Before starting the blades, check that the main power switch servicing the machine is on.

**See Figure 3-2.** Start the blade motors. To do this, turn the switch to the “1” position and then push the START button on the control panel (see the figure below). The motor should start and the feed rollers should start.

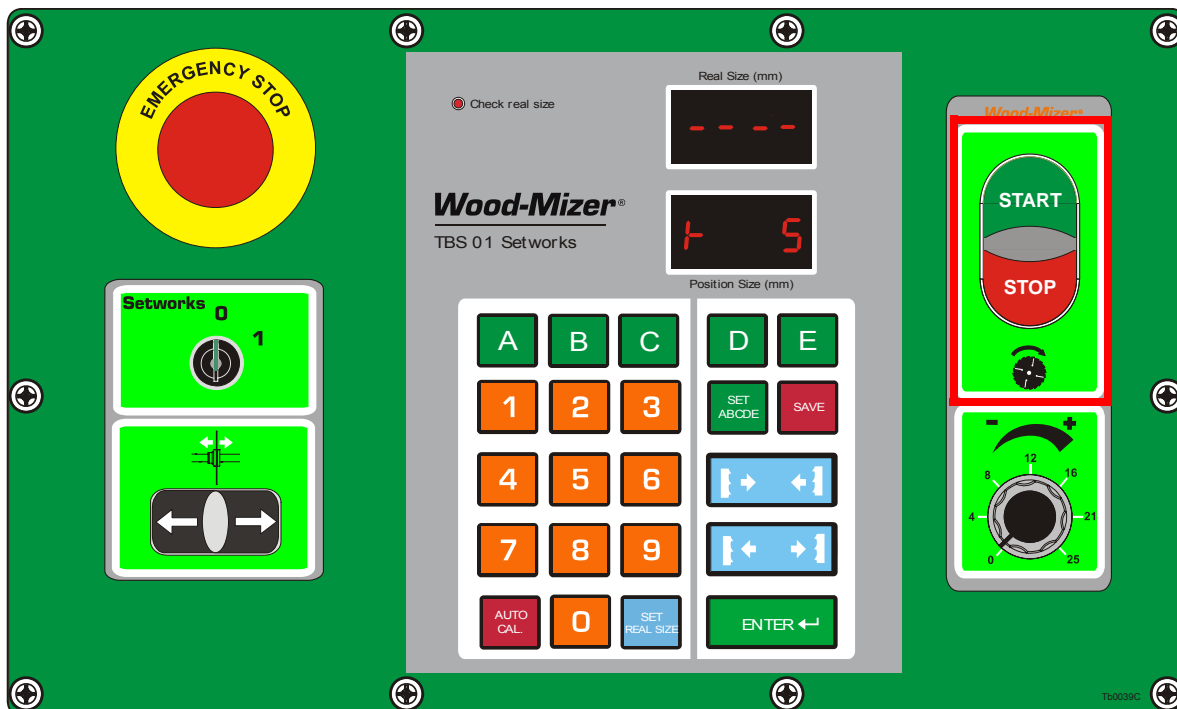

**FIG. 3-2**

To stop the blade motor, push the Stop button shown in the figure above. The motor also may be stopped by pushing the emergency stop button.

See **Figure 3-3**. The speed at the feed rollers move is adjustable by dial located on the control panel, allows the operator to adjust the feed rate from 0 to ca. 25 m per minute.

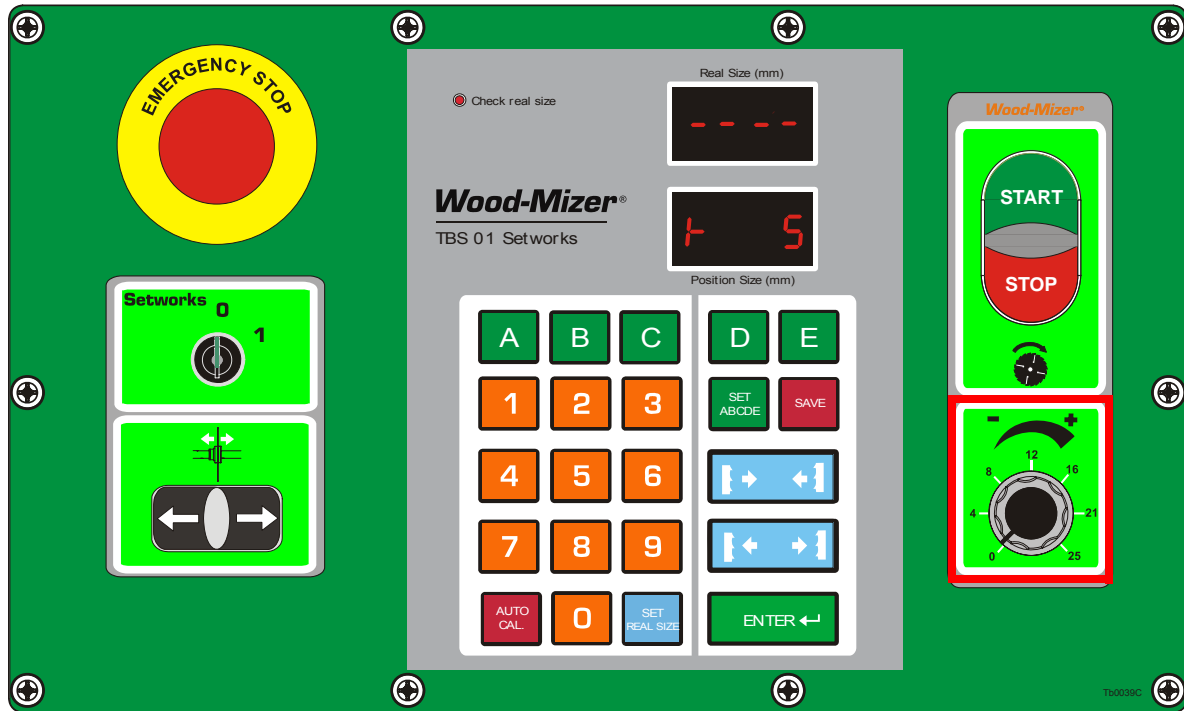

**FIG. 3-3**

Turn the switch clockwise to increase the feed rate, counterclockwise to slow the feed rate down.

**Factors that will determine what feed rate you can use include:**

- Material thickness.
- Hardness of material to be cut. Some woods that are seasoned or naturally very hard will require slower feed rates.
- Sharpness of blades. Dull or improperly sharpened blades will require slower feed rates than sharp and properly maintained blades.
- Off-bearing capability. Your ability to feed will also determine what feed rate you can use.

## 3.5 Blade Installation

### *Multirip Option*

The main shaft's strength and motor horsepower allows you to use maximally five blades with your Edger. Using more blades may make the cutting parameters worse and cause the shaft to crack. The standard Wood-Mizer Edger is equipped with two blades. The additional three blades in Edger are installed on the provided bushing with spacers.

The blades should be installed on the main shaft in the following order:

- movable blade arbor,
- fixed blade arbor,
- bushing with three blades.

**NOTE:** It is necessary to adjust the movable blade limit switch after installing the bushing with additional blades. To do that, measure the distance from the left edge of the fixed blade arbor to the left edge of the bushing with additional blades (see the figure below). Then loosen the screws and move the limit switch left, the measured distance.



**WARNING!** Failure to adjust the safety switch after installing additional blades may result in machine damage.

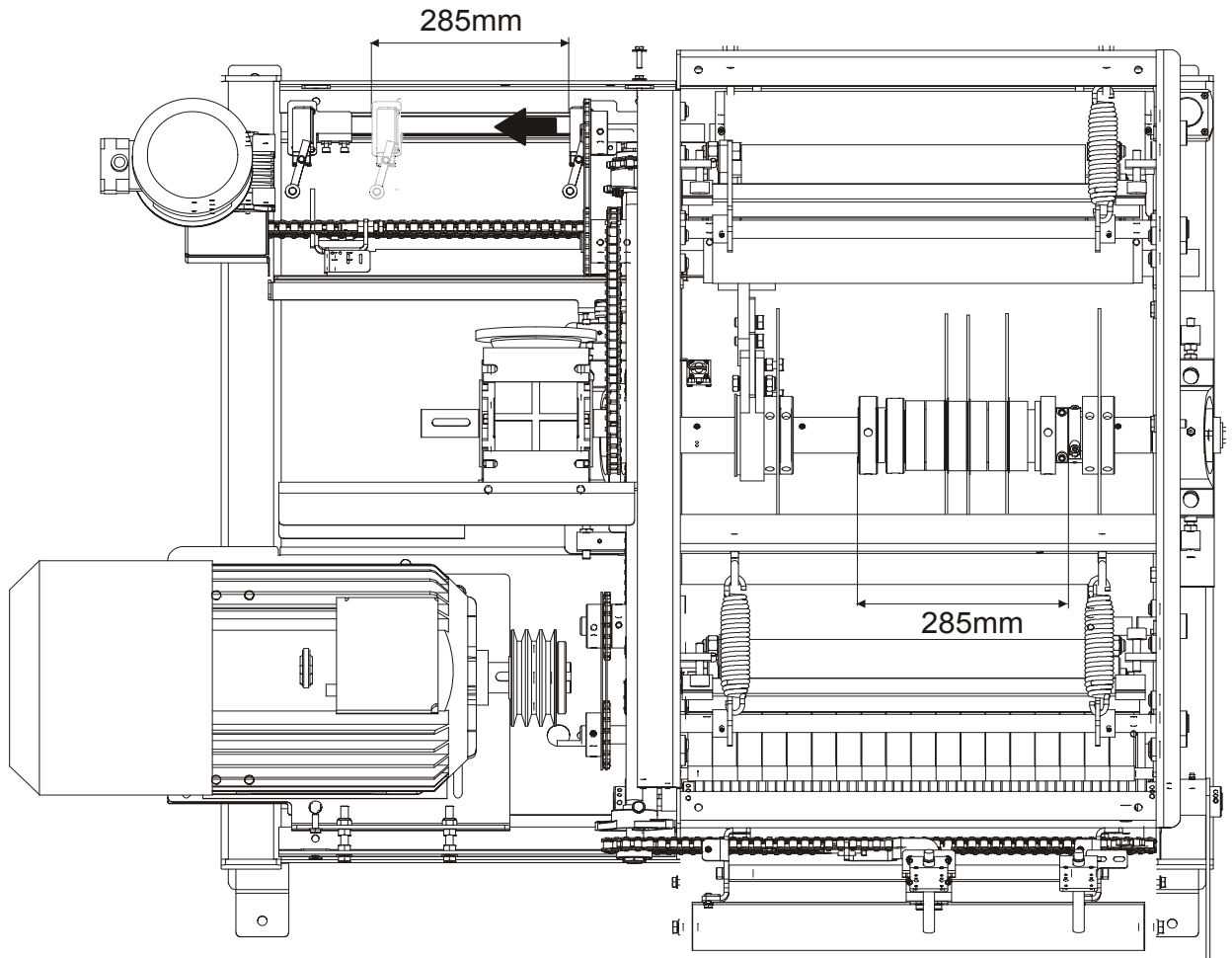

**FIG. 3-3**

**NOTE:** After installing the additional bushing with blades, you should turn off the Networks controller because the remaining range of movable blade movement is insufficient for performing the auto-calibration. However, you can still automatically move the movable blade in the remaining range of its movement - using the additional blades distance setting switches located below the Networks controller ON/OFF switch.



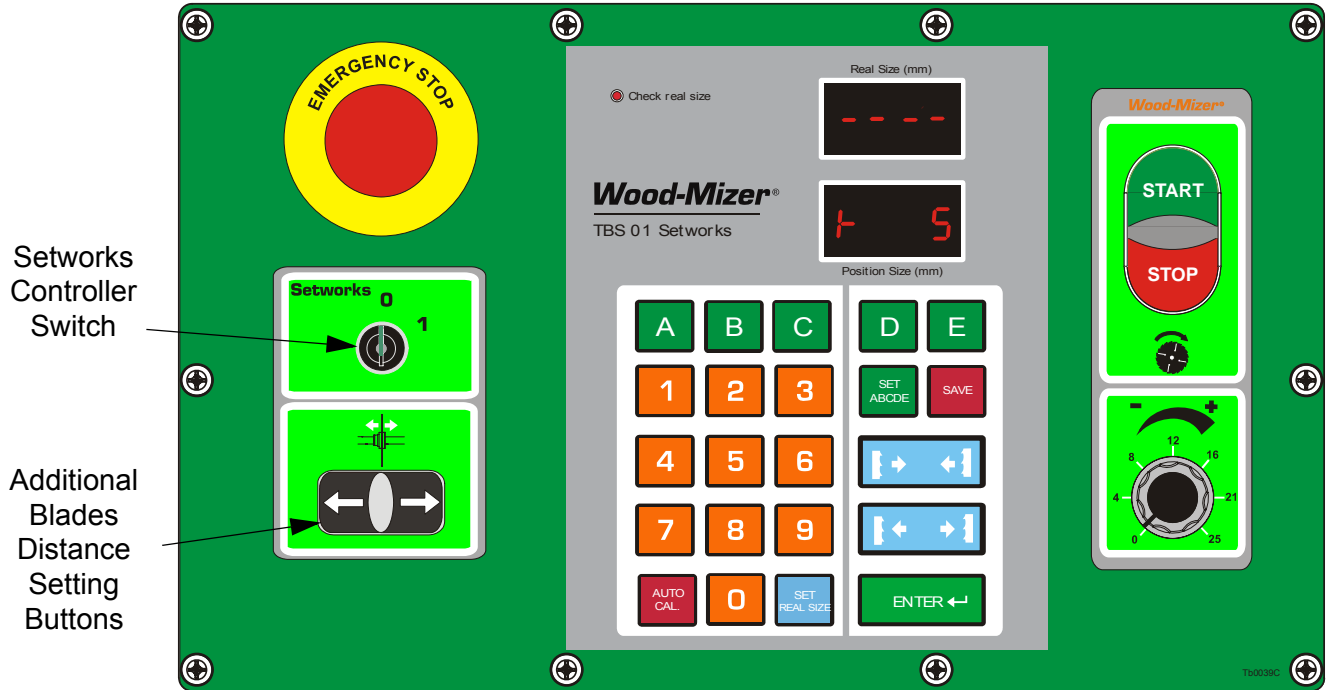

FIG. 3-3

The table below will help you choose suitable thickness and number of spacers for various numbers of blades and distances between them. Use the toolmaker's table to mount the blades on the bushing and then install the bushing assembly to the Edger. You can also mount two bushing assemblies on the shaft, however no more than five blades. To do this, you have to order an additional bushing with spacers.

Ref.	Board Width	Maximum number of blades	Thickness and number of spacers behind each blade except the last one G [mm]				Thickness and number of spacers filling the spacing behind the last blade (up to the nut)					
			G=26,1	G=5	G=10	G=20	A - 4,2mm	B - 6,4mm	C - 7,8mm	D - 5,0mm	E - 10,0mm	F - 20,0mm
							Number of spacers					
1	25	5	1	0	0	0	1	0	0	1	0	1
2	25	4	1	0	0	0	0	0	1	0	1	2
3	30	4	1	1	0	0	0	0	1	1	1	1
4	35	4	1	0	1	0	0	0	1	0	0	1
5	40	4	1	1	1	0	0	0	1	1	0	0
6	25	3	1	0	0	0	0	1	0	0	0	4
7	30	3	1	1	0	0	0	1	0	0	1	3
8	35	3	1	0	1	0	0	1	0	0	0	3
9	40	3	1	1	1	0	0	1	0	0	1	2
10	45	3	1	0	0	1	0	1	0	0	0	2
11	50	3	1	1	0	1	0	1	0	0	1	1
12	55	3	1	0	1	1	0	1	0	0	0	1
13	60	3	1	1	1	1	0	1	0	0	1	0
14	65	3	1	0	0	2	0	1	0	0	0	0
15	25	2	1	0	0	0	0	0	0	1	1	5
16	30	2	1	1	0	0	0	0	0	0	1	5
17	35	2	1	0	1	0	0	0	0	1	0	5
18	40	2	1	1	1	0	0	0	0	0	0	5
19	45	2	1	0	0	1	0	0	0	1	1	4
20	50	2	1	1	0	1	0	0	0	0	1	4
21	55	2	1	0	1	1	0	0	0	1	0	4
22	60	2	1	1	1	1	0	0	0	0	0	4
23	65	2	1	0	0	2	0	0	0	1	1	3
24	70	2	1	1	0	2	0	0	0	0	1	3
25	75	2	1	0	1	2	0	0	0	1	0	3
26	80	2	1	1	1	2	0	0	0	0	0	3
27	85	2	1	0	2	2	0	0	0	1	1	2
28	90	2	1	1	0	3	0	0	0	0	1	2
29	95	2	1	0	1	3	0	0	0	1	0	2
30	100	2	1	1	1	3	0	0	0	0	0	2
31	105	2	1	0	0	4	0	0	0	1	1	1
32	110	2	1	1	0	4	0	0	0	0	1	1
33	115	2	1	0	1	4	0	0	0	1	0	1
34	120	2	1	1	1	4	0	0	0	0	0	1
35	125	2	1	0	0	5	0	0	0	1	1	0
36	130	2	1	1	0	5	0	0	0	0	1	0
37	135	2	1	0	1	5	0	0	0	1	0	0
38	140	2	1	1	1	5	0	0	0	0	0	0

FIG. 3-3

**NOTE:** The minimum distance between two blades can be 25mm. The maximum distance between the blades can be as follows:

- for 2 blades 140 mm

- for 3 blades 65 mm
- for 4 blades 40 mm
- for 5 blades 25 mm

***Additional Fixed Blade Option***

The edger can be equipped with an additional fixed blade (optional equipment).

**NOTE:** It is necessary to readjust the movable blade limit switch after mounting the additional fixed blade (or blades). To do that, measure the distance from the left edge of the fixed blade arbor to the left edge of the last added blade (see the figure below). Loosen the mounting screws and move the limit switch left, the measured distance.

 **WARNING!** If the limit switch is not readjusted after mounting additional blades, damage to the machine equipment may occur.

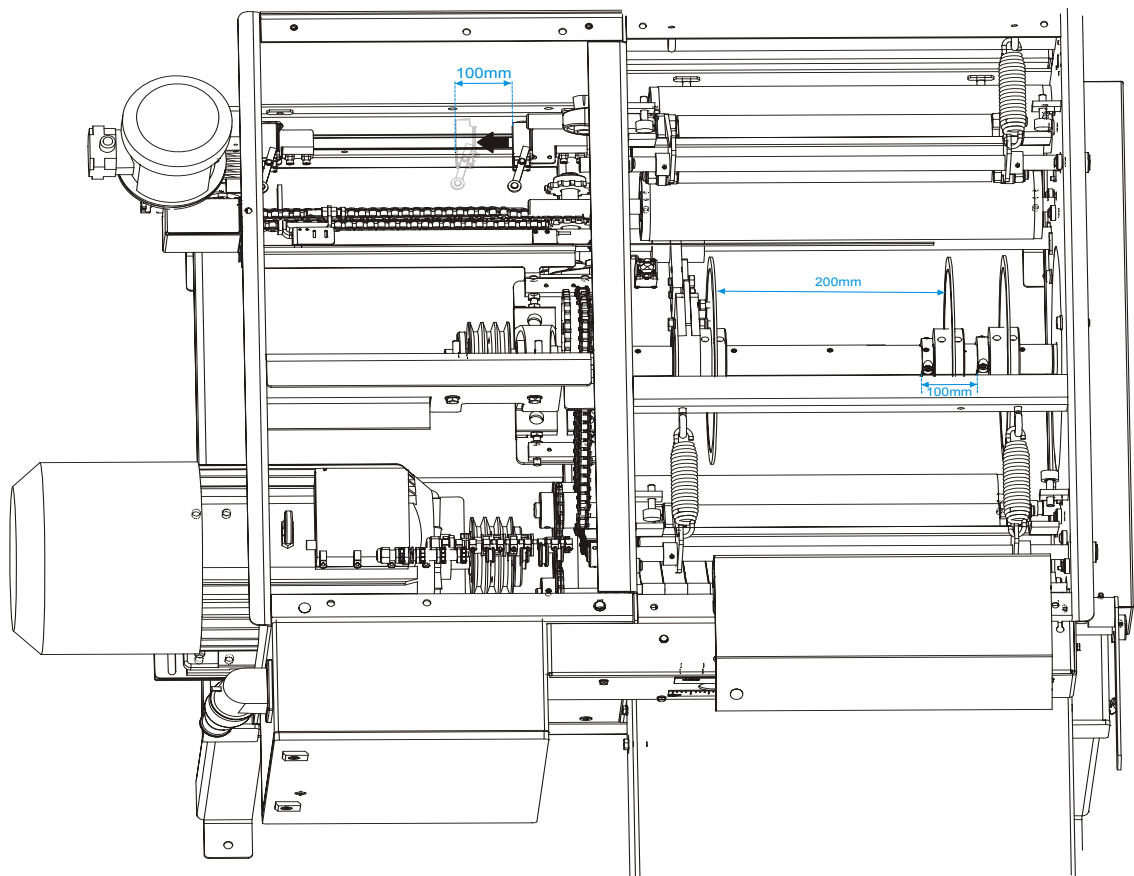

**FIG. 3-3**

## 3.6 Edging Lumber



**DANGER!** Make sure all guards and covers are in place and secured before operating the Edger. Failure to do so may result in serious injury.

**DANGER!** Keep all persons out of the path of moving equipment and boards when operating the Edger or loading boards. Failure to do so will result in serious injury.

**DANGER!** Moving Parts Can Crush and Cut. Keep hands clear. Make sure all guards and covers are in place and secured before operating or towing. Failure to do so may result in serious injury.

**DANGER!** Maintain a clean and clear path for all necessary movement around the Edger and lumber stacking areas. Failure to do so will result in serious injury.



**WARNING!** Always shut off the motor to stop the blade whenever the Edger is not in use. Failure to do so may result in serious injury.

**WARNING!** Always wear eye, ear, respiration, and foot protection when operating the Edger. Failure to do so may result in serious injury.

**WARNING!** Secure all loose clothing and jewellery before operating the Edger. Failure to do so may result in serious injury or death.

After performing the pre-operation check, you are ready to begin edging lumber.

1. Start the machine.
2. Place the board on the infeed table.
3. If one side of the board is edged, place the board with the squared edge against fence.

See Figure 3-4. The board guide fence allows guide the board parallel. Release the locking bolt to adjust the board guide fence.

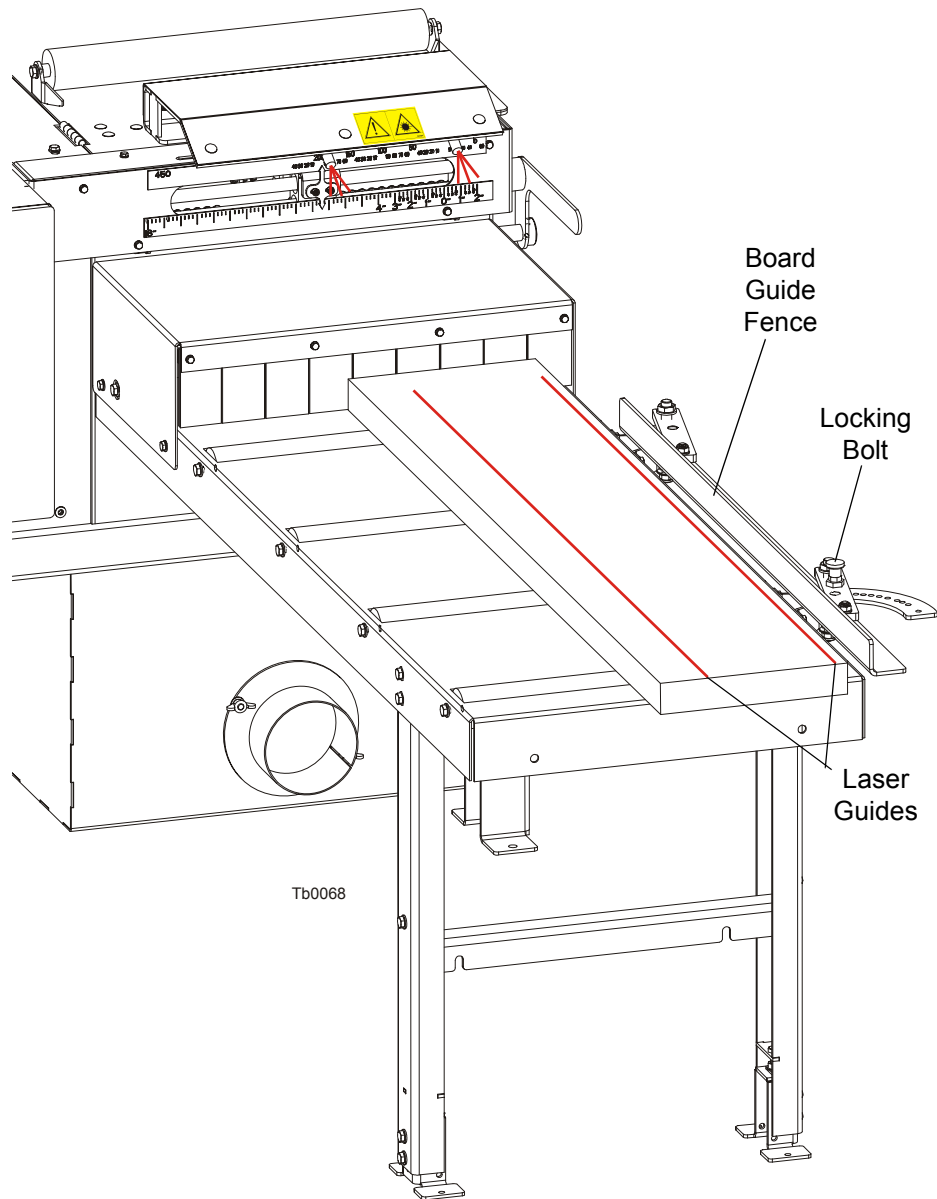

FIG. 3-4

4. Move the blades as desired. If using a fence as a guide, use the corresponding scale to determine the width of the board after edging. The laser will show the path of the blade to help you decide how wide to cut. If edging both sides of the board, use the scale at the top of the edger and or setworks display to determine the width of cut. Again, the lasers show the path of the blades. For instructions how to use Setwork, [See Section 4.1 Edger Controller Panel](#)
5. Start the blade motor and the feed motor. Set the board feed speed as desired. Push the board into the edger until the feed system takes the board.



**IMPORTANT!** If at any time you need to immediately stop the motor and/or Edger operation, press the Emergency Stop button located at

the front or at the rear of the Edger.

6. Repeat the above procedures for all boards to be edged.
7. Shutdown the machine when done edging.

SECTION 4 NETWORKS OPERATION

4.1 Edger Controller Panel

See Pic. 4-1.

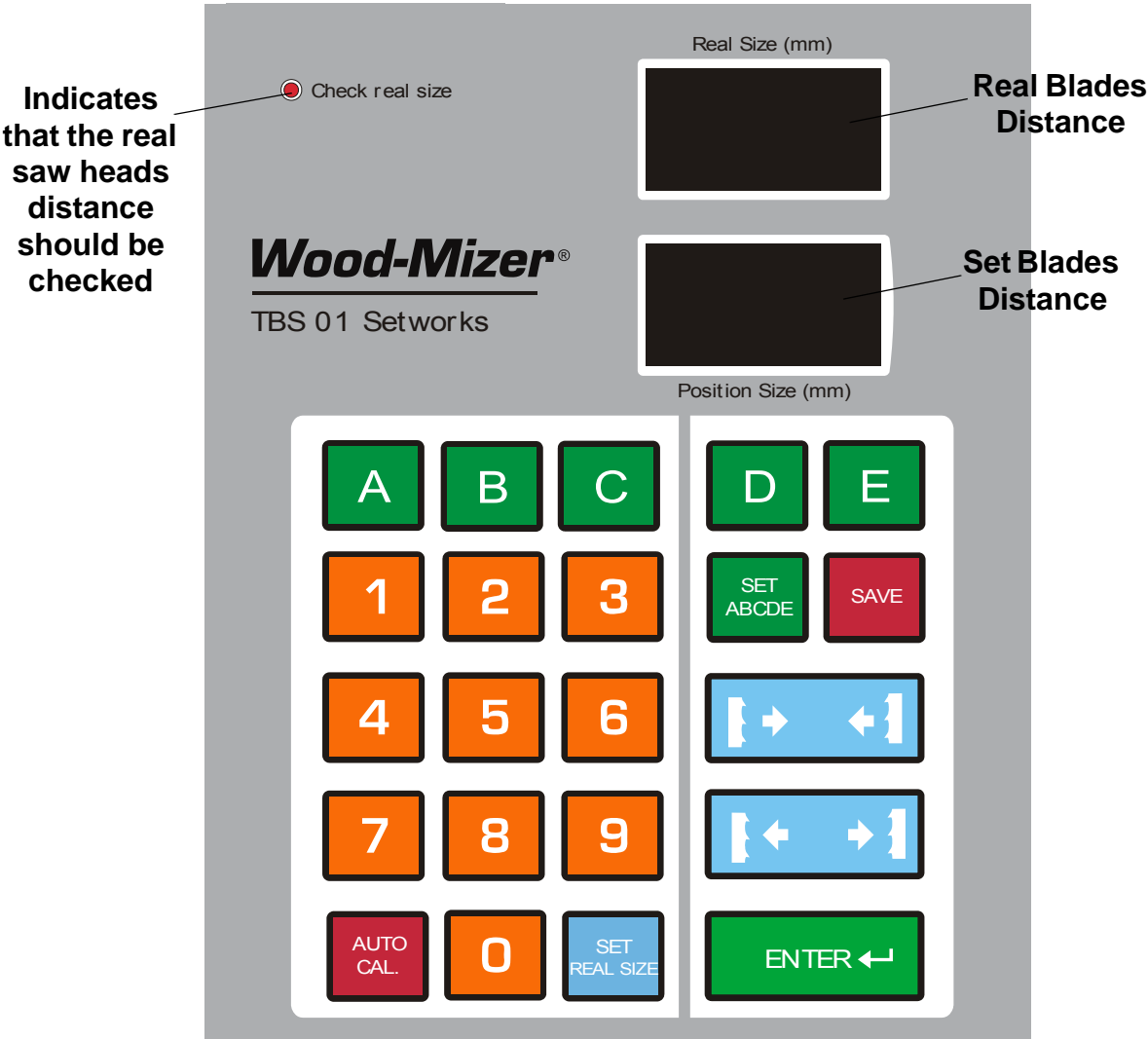

PIC. 4-1

**Descriptions of the control panel buttons:**

A, B, C, D, E - blades width memory buttons.



SET ABCDE - Sets the blades width value to each memory button.



Save - Saves parameters determined by operator.



Blades width manual setting buttons (in/out).



ENTER ← – enters the value to the memory



Auto Mode – Adjustment of the networks automatic calibration parameters. Used for initial calibration and re-calibration if dimensional error occur.



Set Real Size - Sets the real distance between saw heads. Should be set when “Check real size” indicator lamp blinks.

**4.2 Start-up settings of the controller****1. Setting the input divider (entered only once, at the first start-up)**

- Switch on the controller by turning the main switch to ON position.
- When the text “TBS-01” appears on the display, press and hold  until the divider value appears on the lower right display.
- Enter the correct value of the divider (for Edger the divider value should be **5**).



See Pic. 4-2.

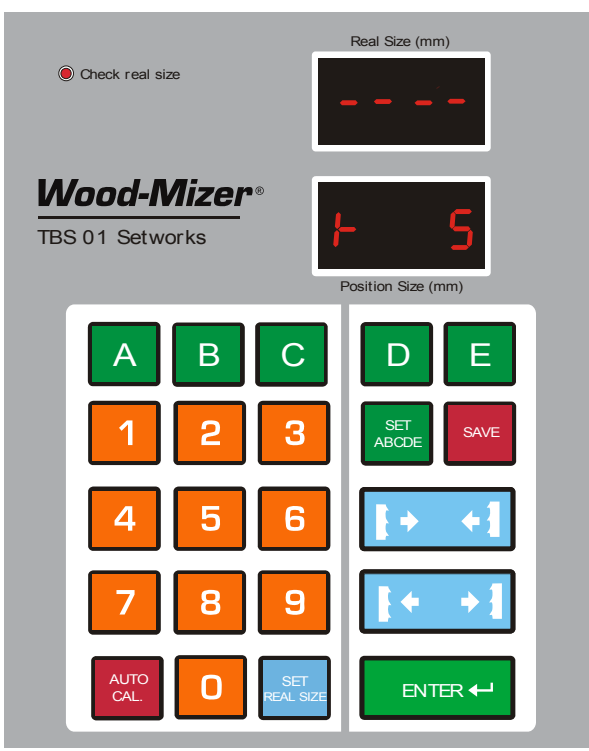



PIC. 4-2

- Press  to save the entered divider value.

1. Auto-calibration



This function should be used in case of: replacement of any component of the blades width setting system, motor or after lubrication of the chains and other moving elements or when significant cutting variances are observed;

- Switch on the edger by turning the main switch to ON position. and wait until the text “TBS-01” disappears.
- Using   buttons set the blades to 180 mm width.
- Press and hold down . After a while - the text “Aut” will appear on the displays. The controller is ready for auto-calibration.

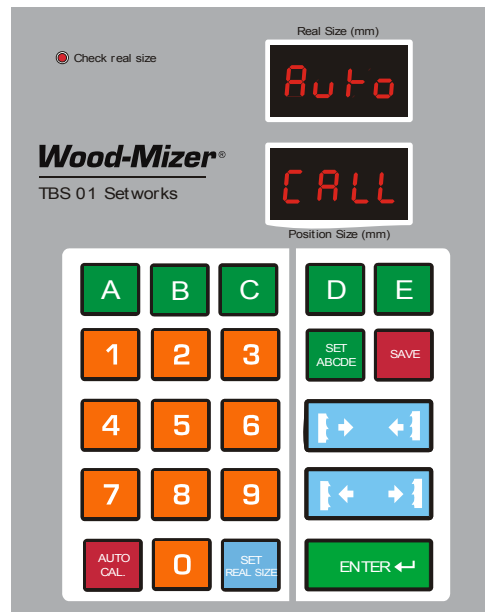
See Pic. 4-3.



PIC. 4-3

- Press  again, the controller successively performs some movements of the blades. After performing the last movement, measure and enter the real head width using the keypad. Confirm by pressing .

## 2. Real blades width entering.

To ensure, that upper display shows the correct blade width, it is necessary to enter real blades width. It must be done on the first start-up and also when:

- significant cutting variances are observed;
- a sudden power disappearance happend when the controller was setting the blade width;
- any repairs to blades drive system was made.

To enter the real blade width:

- Press and hold 
- Using the the scale, set the blades to full measurement (for ex. 250mm)
- Measure the distance between the blades and make sure if the measured distance is the same as



on the scale. If not, [See Section 5.7](#) for alignment instructions.

- Enter the distance between the blades without any pauses. Confirm by pressing .



### 4.3 Operation, Memory Buttons (A, B, C, D, E)

After switching-on, the TBS-01 inscription appears on the display, and the networks is ready for operation within a few seconds or after  is pressed.

- To set the blades to any width, enter the blades width value using keypad and press . The blades will automatically move to the entered width value.

- You can also change the blades width manually using  .

You can store up to 5 blades width values using the memory buttons.

- To store the width value using the memory button, press and hold . On the upper display the “ABC” will appear. Press the memory button (A, B, C, D or E), enter the width value and confirm by pressing . Perform the same procedure for other memory buttons. Press  to exit this function.

## 4

# NETWORKS OPERATION

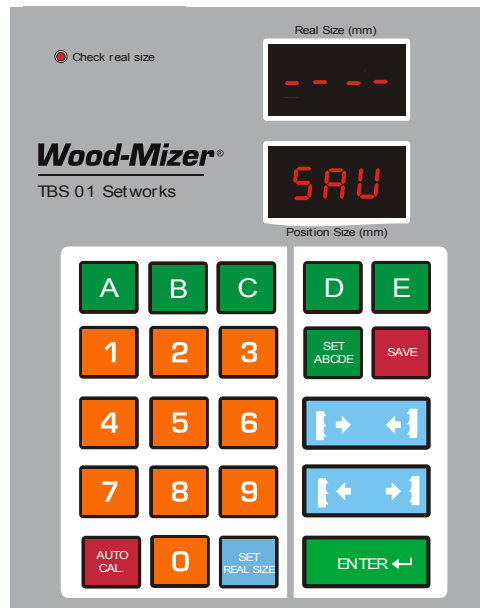

## Operation, Memory Buttons (A, B, C, D, E)

See Pic. 4-4.



PIC. 4-4

- To use the stored value, press the required memory button and confirm by pressing . The blades will move to the stored width.

**NOTE:** If during normal operation the “Check real size” lamp start blinking, press and hold the  button. Measure and enter the distance between the blades with an accuracy of 0,1 mm. For example: if you want to enter 102mm - press **1-0-2-0** without any pauses and confirm by pressing .

## SECTION 5 MAINTENANCE & ALIGNMENT

### 5.1 Changing the Blades

1. Replace the blades as necessary. Dull blades will cause the motor to work harder and will result in decreased cut quality and accuracy. Blade life will vary depending on maintenance of machine, operator, species of wood being sawn, and condition of wood being sawn.

 **DANGER!** Before changing the blades, make sure the arbor has come to a complete stop and the motor is shut off completely. Turn the main switch to "0" position and disconnect the power cord. Failing to do so can cause serious injury.

 **WARNING!** Always wear eye, glove and foot protection when handling saw blades.

2. To access the blades, unbolt and open the blade housing cover.
3. With the shaft secured, use the provided spanner wrenches to loosen the locking nuts on the blades.
4. Remove the cone/bearing assembly from the Edger. To remove, first unbolt and remove the blade shaft bearing guard. Loosen the cone retaining bolt. Remove the cone. If is not possible to remove the cone freely, use the bearing puller. Remove the three mounting nuts on the bearing plate and pry the plate from the Edger.

See Figure 5-1.

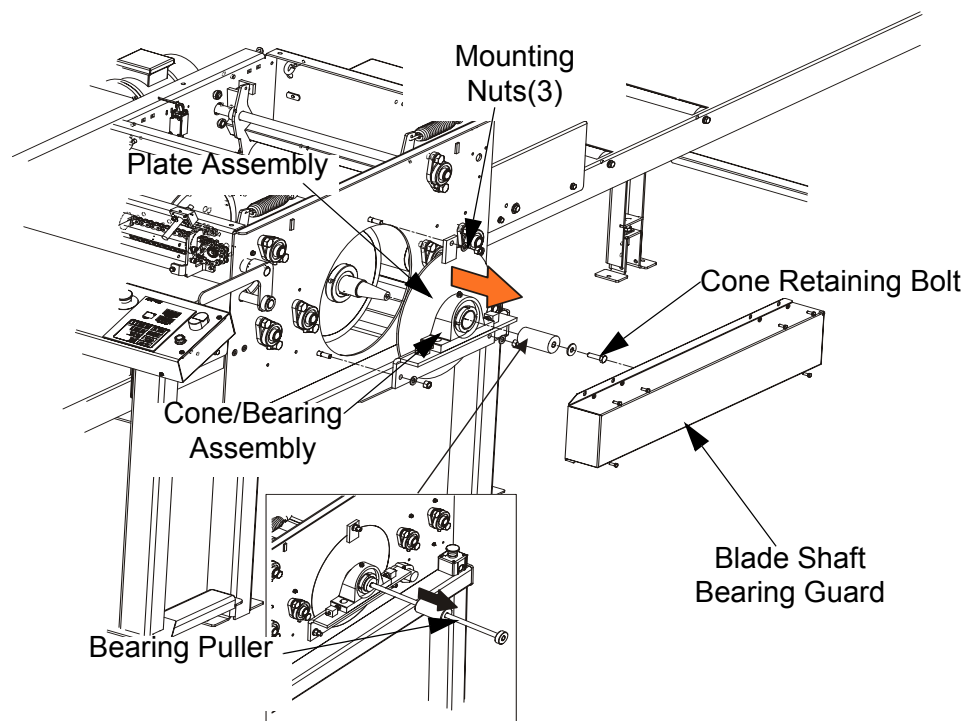
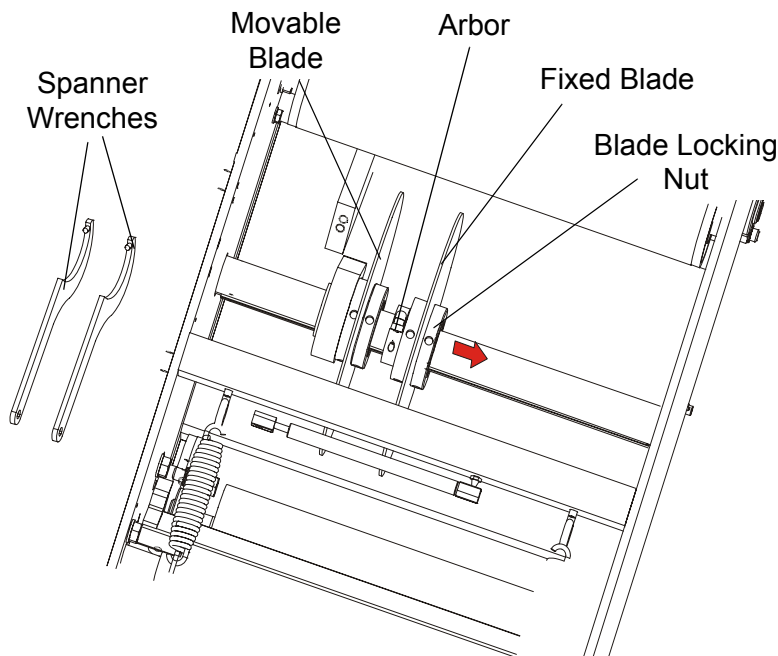

FIG. 5-1

5. Next, remove the blades from the shaft. To do this, remove the fixed blade locking nut using the provided spanner wrenches and next remove the fixed blade. Loosen the two allen screws on the fixed blade arbor and remove the arbor from the shaft.
6. Unscrew and remove the adjustable blade locking nut. Slide the movable blade from the shaft.

**See Figure 5-2.**



**FIG. 5-2**

7. Apply an anti-seize lubricant to the face of the arbor and to the face and threads of the blade locking nut.
8. Install a new or resharpened blade to shaft and position it next to the movable blade arbor. Loosely reinstall the adjustable blade locking nut.
9. Reinstall the fixed blade arbor to the shaft. Install a new or resharpened blade, and loosely reinstall the fixed blade locking nut.
10. Reinstall the cone/bearing assembly and secure in place with the existing mounting nuts.
11. Reinstall the cone retaining bolt and the blade shaft bearing guard.
12. With the shaft secured, use the spanner wrenches to tighten the blade locking nuts all the way.
13. Align the blades. [See Section 4.7.](#)
14. During alignment, the blade arbor allen screws will be tightened to secure the blade assemblies in place.
15. After alignment, be sure to close and re-secure the blade housing cover.

## 5.2 Tensioning the Belts



**DANGER!** Always shut off the motor and allow all moving parts to come to a complete stop before removing any guards or covers. Failure to do so will result in serious injury.

Before tensioning the belts, make sure the motor is shut off completely and the main switch is in "0" position. Disconnect the power cord. Failing to do so can cause serious injury.



**WARNING!** Do not for any reason adjust the motor drive belts with the motor running. Doing so may result in serious injury.



**CAUTION!** Never apply belt dressing as this will damage the belt and cause early failure.

1. Check the drive belts for wear every 8 hours of operation and more frequently during the first 24-48 hours of operation. Tension or replace as necessary. Tension should be 14mm deflection with 4 kg of force for new belts or 14mm deflection with 2,7kg of force for used belts. In case of damage of one belt, we recommend to replace all three belts.

To tension the drive belts:

- Unbolt and open the gearbox housing cover.
- Locate and loosen the mounting bolts which secure the motor plate to the edger weldment.
- Using adjustment bolts, tension or loosen the belts. Be sure to adjust the bolts evenly so the motor remains in alignment.



**CAUTION!** Do not over tighten the drive belt as it can cause premature belt and/or bearing failure.

**CAUTION!** Do not under-tighten the drive belt as it can cause one or all of the following damages: slippage of the belt on the drive pulley, binding or fetching up of the blades while in the cut, damage or bending of blades.

- Retighten the motor plate mounting bolts.

2. Close the gearbox housing cover and use the existing bolts to secure.

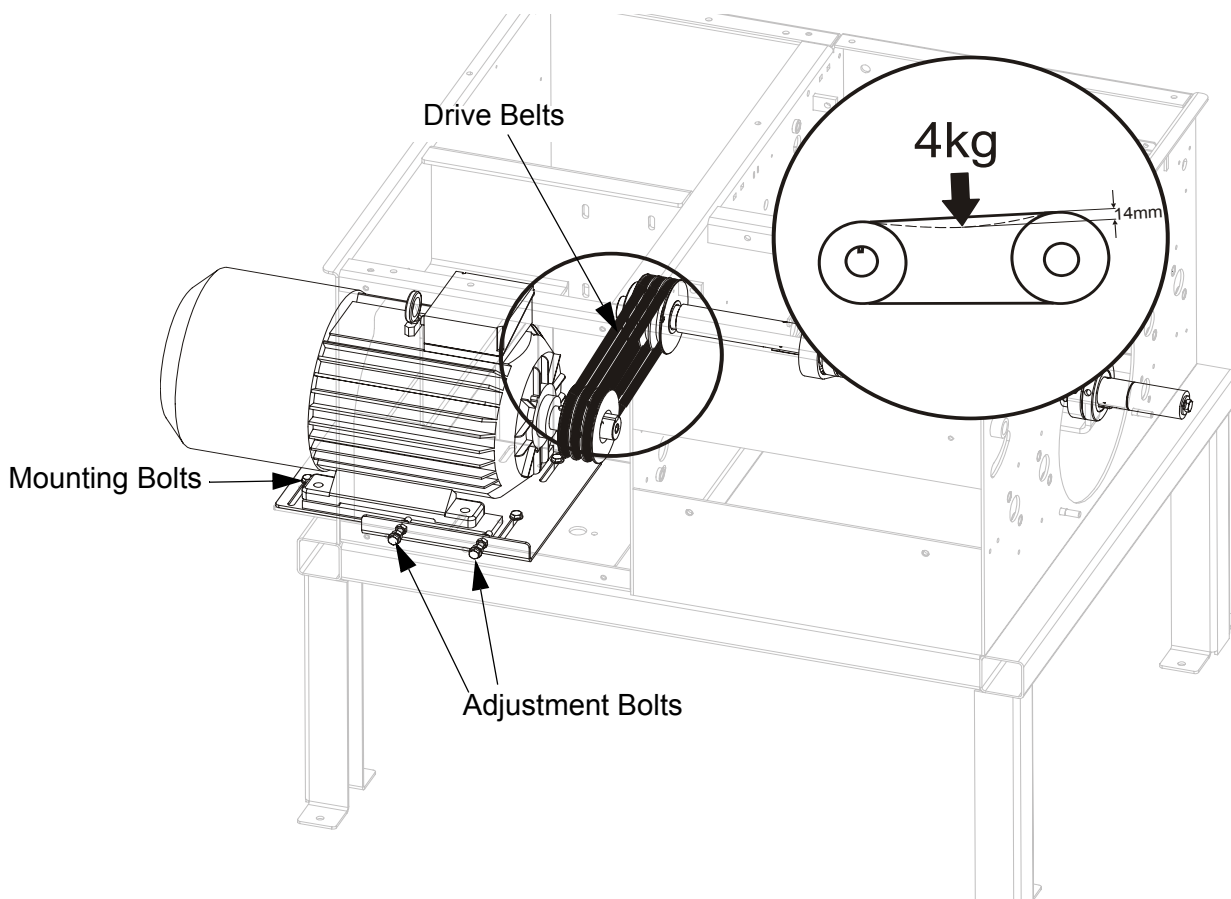

FIG. 5-2

## 5.3 Tensioning the Chains

### Board Feed Drive Chains

40

Check the board feed drive chains for tension every 40 hours of operation and tension as necessary. The chains should have approximately 15mm of slack. **NOTE:** The smaller idler chains have no adjustment.

See Figure 5-3. To tension the drive chains, unbolt and open the gearbox housing cover.

- Loosen the four gearbox mounting bolts.
- Use the adjustment bolts underneath the gearbox to raise the gearbox until the chains are tensioned as needed. Be sure to adjust the bolts evenly.



- Retighten the gearbox mounting bolts and close and secure the gearbox housing cover.

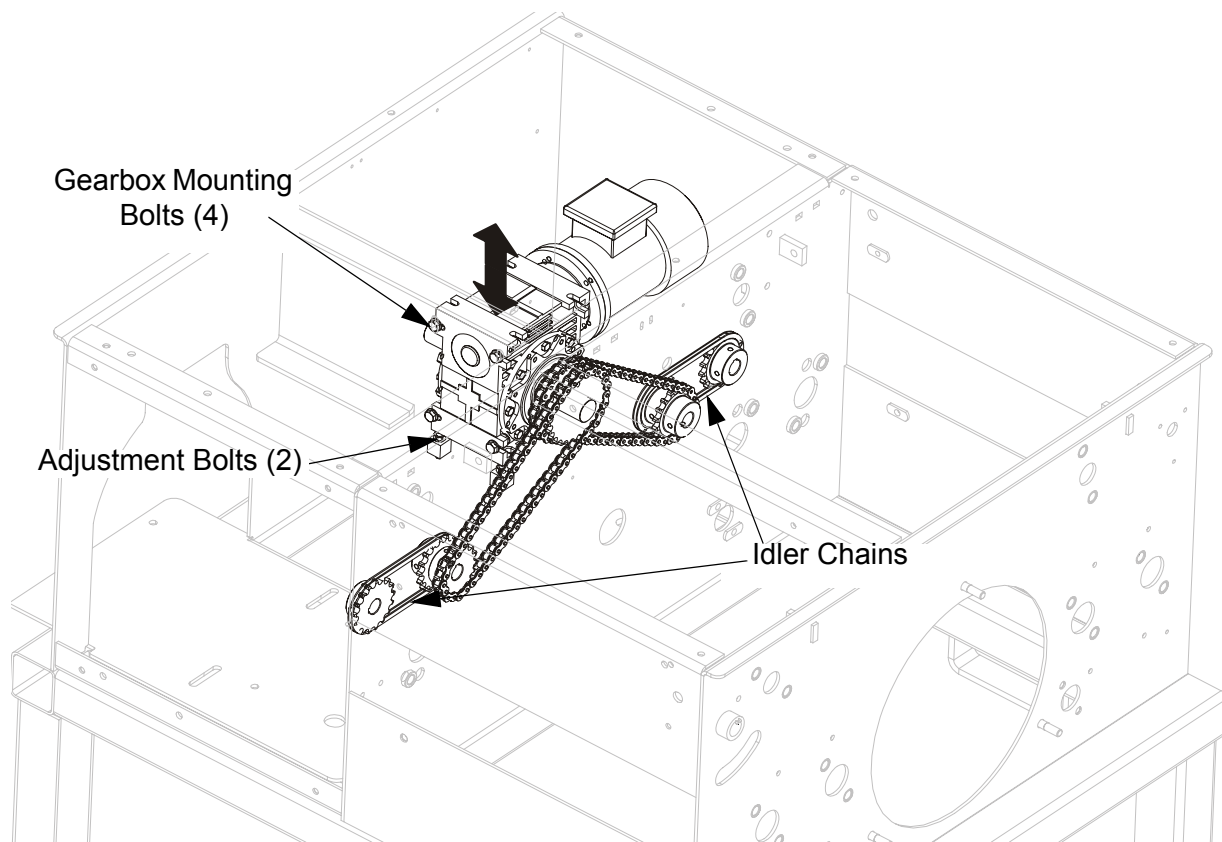

FIG. 5-3

### Blade & Laser Positioning Chains

100

Check the blade and laser positioning chains for tension every 100 hours of operation and tension as necessary. The chains should have approximately 15mm of slack. **NOTE:** The chain tension affects cutting accuracy.

**See Figure 5-4.** To tension the blade and laser positioning chains, unbolt and open the gearbox housing cover and lasers cover. Using the chain tensioner set the appropriate tension. Loosen the locking nut. Holding the adjustment bolt, turn the adjustment nut right to tighten the chain or turn the adjustment nut left to loosen the chain. After that, tighten the locking nut. The laser positioning chain tension is set in the same way.

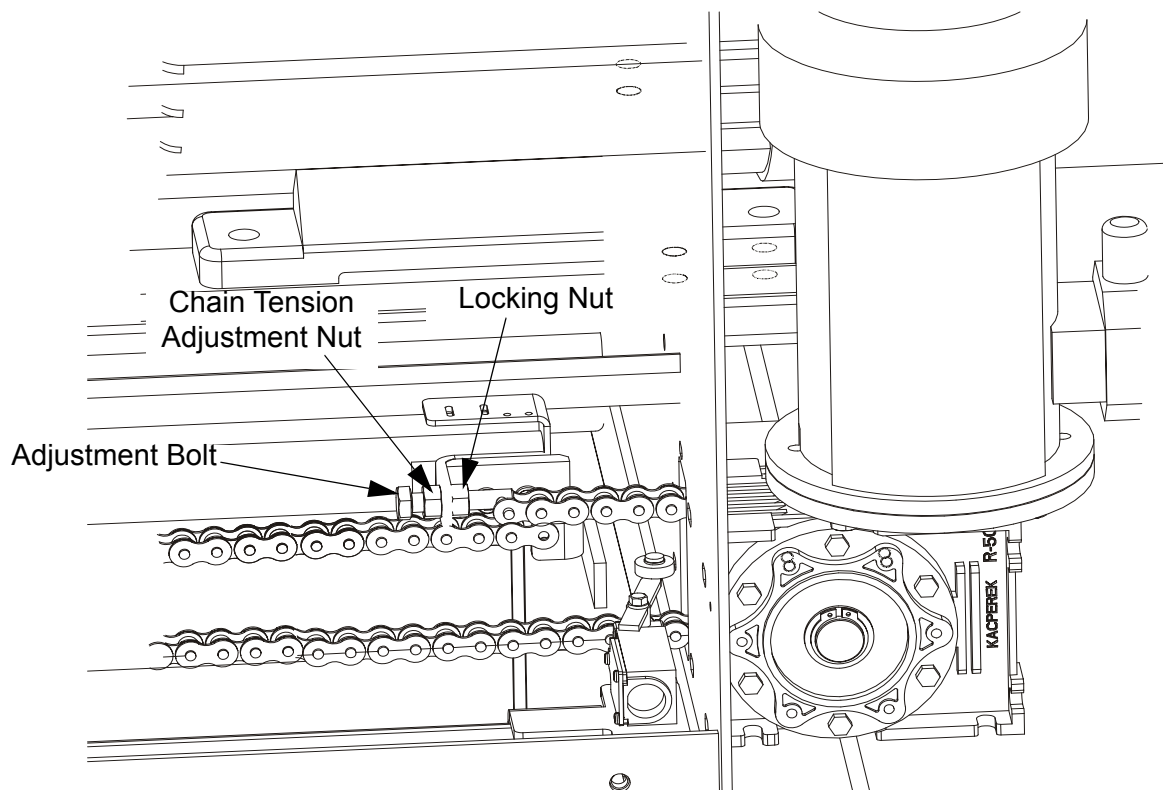

FIG. 5-4

## 5.4 Checking the Rollers

1. Check the feed rollers every 8 hours of operation. Remove any dirt or debris from the rollers. Make sure they spin freely, without much play. Replace the spring-loaded feed rollers as needed.
2. Check the press rollers every 8 hours of operation. Clean any debris or sap buildup from the rollers with a wire brush. Replace the press roller bearings if there is any play in the rollers.

## 5.5 Lubrication

1. Clean any debris from the blade drive shaft and every 8 hours of operation. Use a soft cloth to apply a dry graphite daily to ensure resistance-free motion and to prevent surface corrosion.
2. Lubricate the blade shaft bearings every 200 hours of operation with one to two pumps of lithium-based grease such as Shell Alvania No. 3. Do not overgrease.
3. Lubricate the anti-kickback shaft pivots every 200 hours of operation with a high-quality lithium-based grease such as Shell Alvania No. 3.
4. Lubricate the press roller bearings every 200 hours of operation with a high-quality lithium-based grease such as Shell Alvania No. 3.
5. Apply anti-seize lubricant to the surfaces and threads of the blade arbors and locking nuts every

blade change ([See Section 4.1](#)).

## 5.6 Maintaining and Sharpening Anti-Kickback Fingers

This machine has the potential for kick-backs. Kick-backs can cause the board to be suddenly and uncontrollably hurled towards the operator. Such action can result in severe injury or death.

If you are working with frozen boards or with boards that have protruding knots, the chance of kickbacks is increased.

The infeed opening of the Edger is equipped with anti-kickback fingers to help prevent kickback from occurring. To maintain the safety of your Edger, periodically inspect the machine to ensure all anti-kickback fingers are intact and undamaged and have a sharp point. Missing or damaged parts can affect the safety of the machine operator or bystanders and should be replaced immediately. Dulled parts should be re-ground with a hand grinder or replaced.



**DANGER!** Always ensure that there is a sharp point on the anti-kickback fingers before each use of the Edger.

Be sure anti-kickback fingers are free from obstruction and are in a downward position with lever released. Failure to do so may result in serious injury.

## 5.7 Alignment



**WARNING!** Before performing service near moving parts such as blades, pulleys, motors, belts and chains, first turn the main switch to the "0" position and disconnect the power cord.



**WARNING!** Coastdown Required. Always shut off the motor and allow all moving parts to come to a complete stop before removing any guards or covers. Do NOT operate with any guards or covers removed.



**WARNING!** Visible and/or invisible laser radiation. Avoid eye or skin exposure to direct or scattered radiation.

### Fixed Blade, Laser and Fence Alignment

1. The position of the fixed blade is adjusted by loosening the blade locking nuts just sufficiently to be able to slide the blade on the shaft.
2. Set the fence to the maximum width, so that the pin is secured in the first hole.
3. Place a 60mm wide bar along the outside edge of the blade and so that the bar is aligned with the 0 mark on the scale and the bar meets the fence. [See Figure 5-5](#).
4. Tighten the blade clamps and check the alignment again.
5. Check if the fixed blade laser indicates the left edge of the bar. If not, loosen the laser mounting bolts

and slide the laser as necessary. Next, tighten the mounting bolts.

See Figure 5-5.

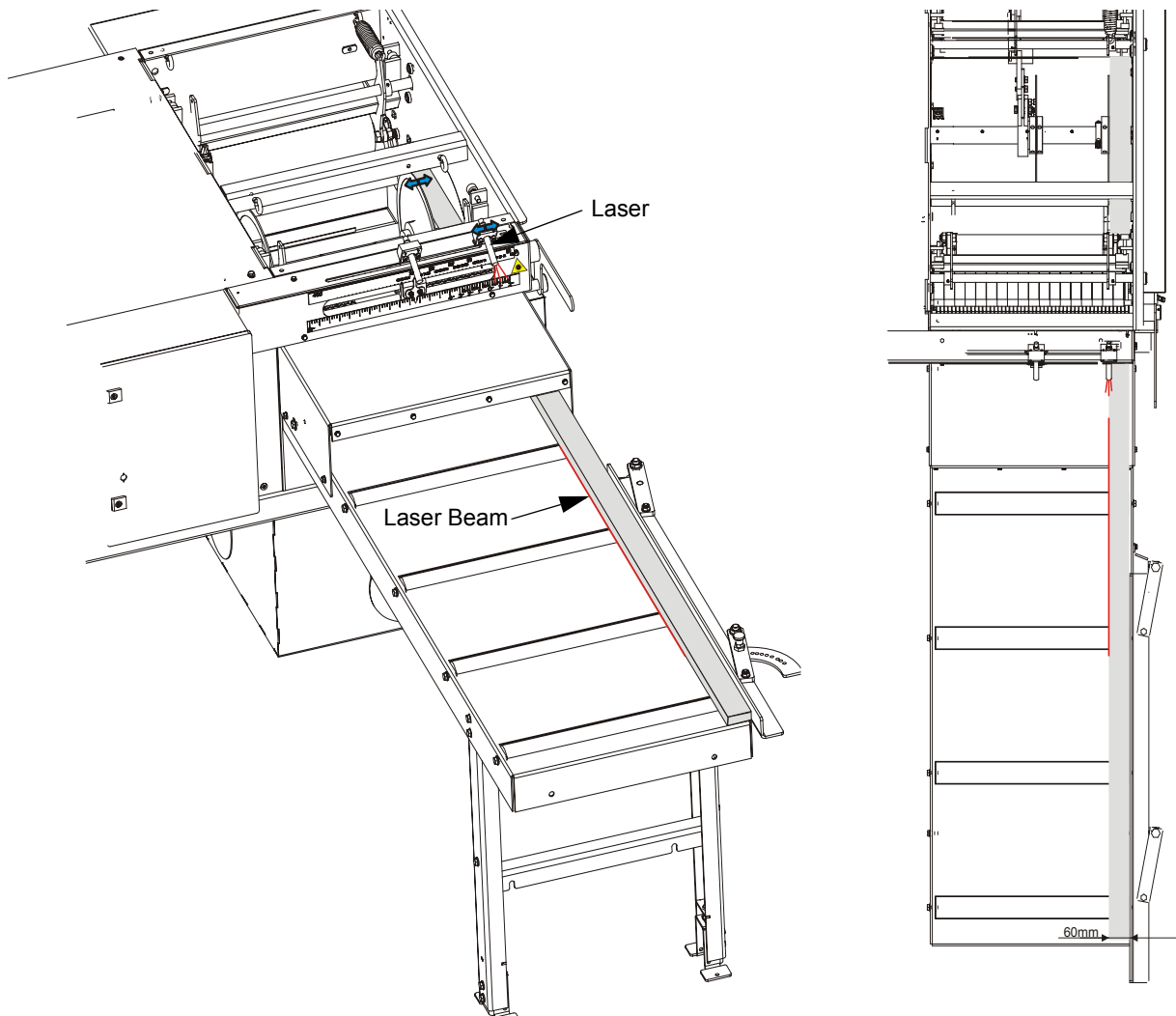



FIG 5-5

### Adjustable blade and its laser indicator alignment

- To position the adjustable blade, set the blade to 200mm using  buttons and scale. Measure from the inside of the fixed blade to the inside of the movable blade. If necessary, loosen the movable blade arm and slide the blade assembly on the shaft until the blades are 200mm apart. Retighten the blade arm. If the adjustable blade has been aligned, it is necessary to perform the auto-calibration procedure and enter the real blade width to Setwork Controller ([See Section 4.2](#)).

Correct the scale indicator position if necessary.

See Figure 5-6.

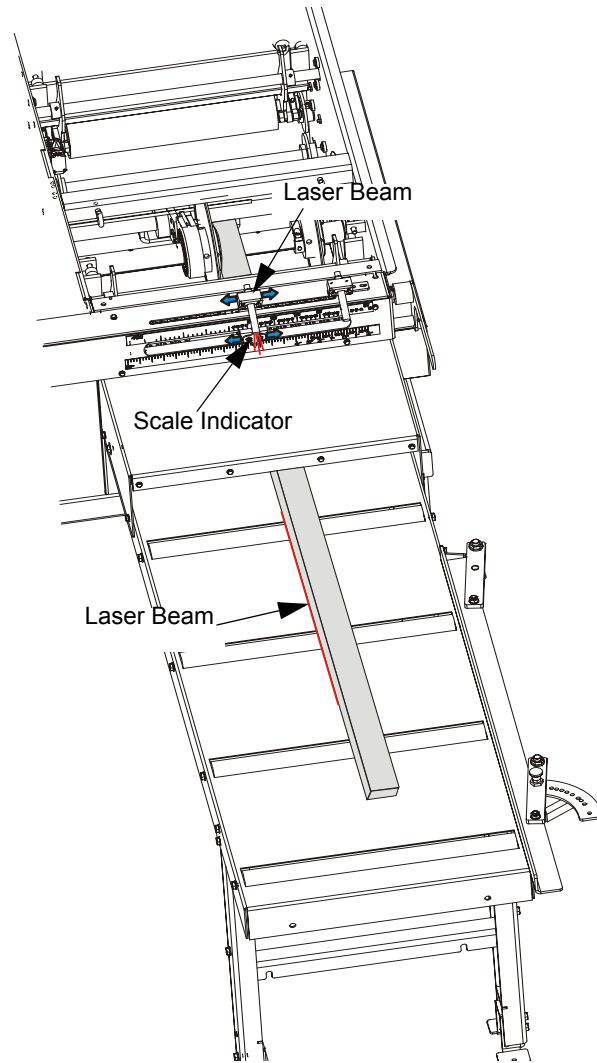

FIG 5-6

## 5.8 Blade Sharpening

The blade teeth should be sharpened as soon as their dullness, measured as shown in the figure on the right, is .10 - .20 mm.



Use diamond grinding wheels for sharpening the blades. Apply intensive cooling during sharpening to prevent overheating and structural changes in the cemented carbide tips.

**Blades with hard tips (GLOTECH series) must be intensively cooled with water during sharpening. Failure to do so will result in cracks in the tips.**

In Multix type blades the carbide tips should be .4 - .6 mm wider than the carbides in the wiper slots. (See the figure below.) If this difference is not kept, it will result in disk overheating and – in extreme case – in cracks in the blade gullets. The carbide plates in the wiper slots remove sawdust and splinters from the kerf. They also cause sawdust to be blown away.

When sharpening, maintain the proper tooth geometry as indicated in the figure below.

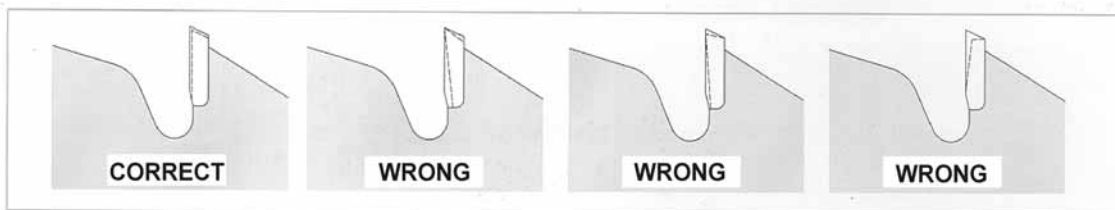
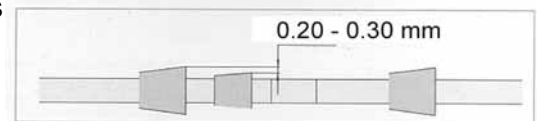

## 5.9 Using the Blades

The surfaces of spacers should be clean and flat against one another. The blade should not rotate on the shaft during sharpening as it will lead to its damage.

It is not recommended to change the blade mounting hole. Unsuitable hole modification will result in decreased breaking strength, increased radial run-out and wavy cuts. Besides, it may result in blade burning, cracks in the gullets and finally in blade breakage.

### **Do not set teeth with cemented carbide tips!**

Do not make any modifications to the blade teeth!

Do not operate the machine if any of the blades is dull. Using dull blades causes stronger cutting resistance, decreased cut accuracy and may result in blade burning and even cracks in the gullets and the wiper slots.

### **Do not exceed the maximum blade rotation speed recommended for a given type of material!**

When using Multix type blades, keep at least 5 mm spacing between the bottom of the wiper slot and the spacer outer diameter.

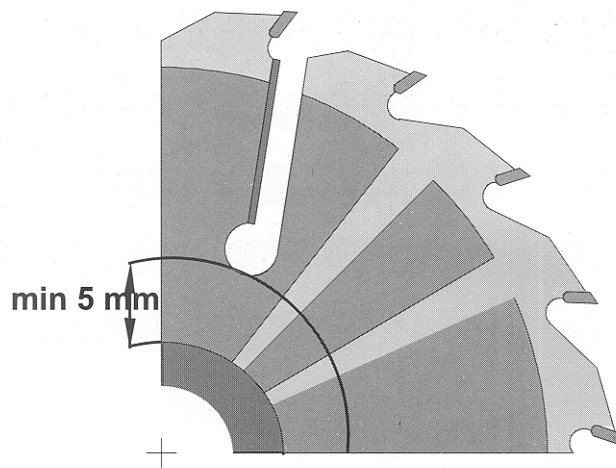

To remove any sawdust buildup from the blade disk, preferably use a solution of hot water and soda or another cleaner.

Any blades which are not used for a longer period of time should be properly maintained.

The blades should be used in accordance with safety rules and their application and with machines in good operating condition and equipped with suitable safety guards.

## SECTION 6 SPECIFICATIONS

### 6.1 Overall Dimensions

See Figure 6-1. The major dimensions of the Edger are shown below (all dimensions are in millimeters).

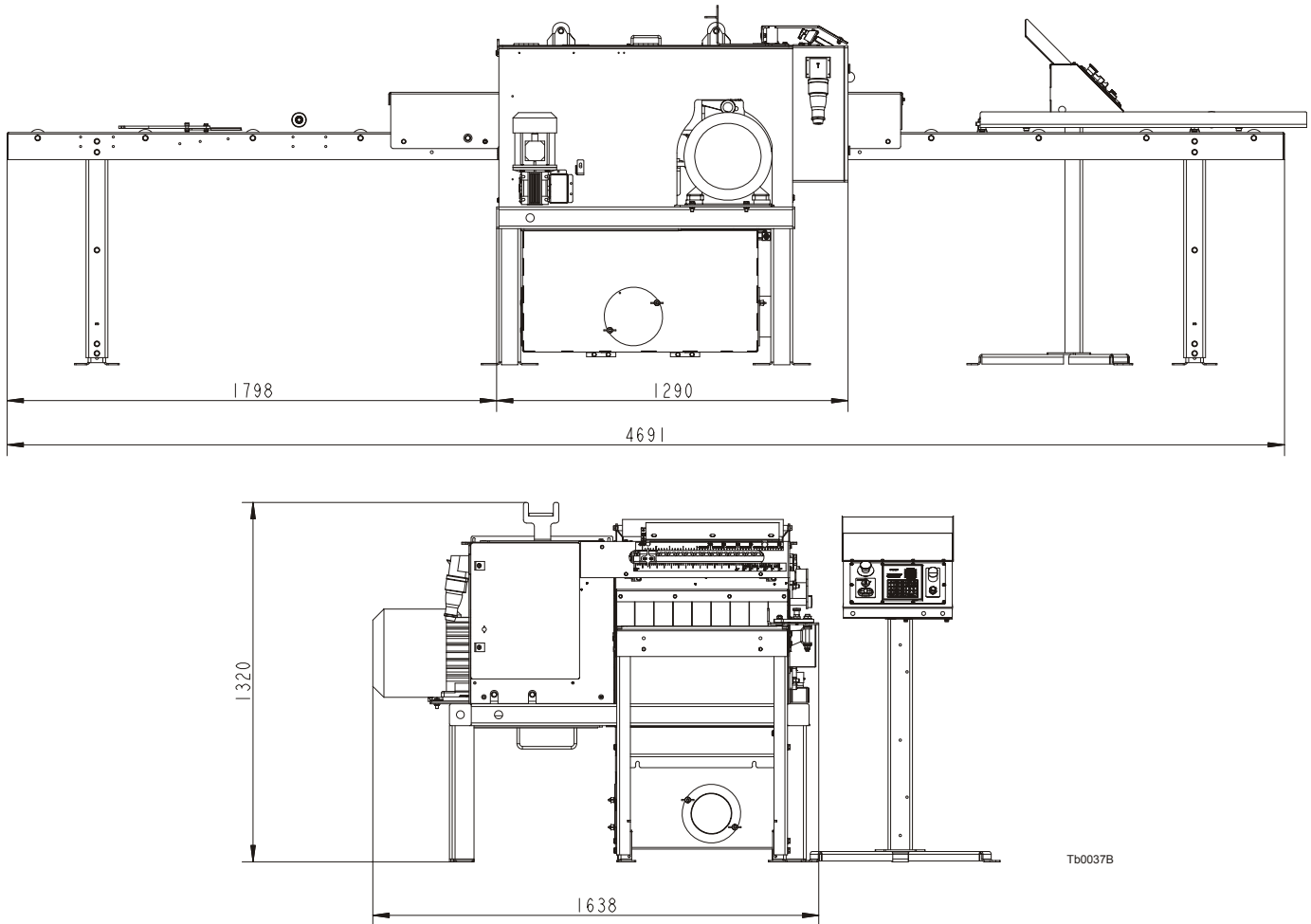

**FIG. 6-1**

See Table 6-1 The overall dimensions of the Edger are listed in the table below.

<b>Weight</b>	988 kg
<b>Height</b>	1320 mm
<b>Width</b>	1638 mm
<b>Length</b>	4691 mm

**TABLE 6-1**



## 6.2 Multirip Edger Specifications

See Table 6-2 The power option specifications of the Wood-Mizer Edger is listed below.

	Motor Specifications	Motor Specifications
Motor Type	E20 Electric Motor	E25 Electric Motor
Manufacturer	Tamel S.A., Poland	INDUKTA
Voltage at 380V	380-420V	380-420V
Maximum Current	26.7 A	32.2 A
Maximum Torque	2920 RPM	2920 RPM
Rated Output	15kW ( 20HP )	18.5kW ( 25HP )
Manufacturer Part #	Sg160M2BHM	SG160ML2HM
WM Part #	087929	096622

**TABLE 6-2**

See Table 6-3 The noise level of the Edger is given below.<sup>1 2</sup>

	Engaged
Edger Equipped With E20 Electric Motor	84 dB (A)

**TABLE 6-3**

See Table 6-4 Other specifications of the Edger are listed below.

Number of Blades	2 - 5
Blade Diameter	350 mm
Feed Speed	0 - 25 m/min
Minimum Board Length	700 mm
Minimum Board Thickness	10 mm
Maximum Board Thickness	60 mm
Maximum Egding Width	420 mm
Maximum Material Width	550 mm

**TABLE 6-4**

1. The noise level measurement was taken in accordance with PN-EN ISO 3746 Standard. The noise exposure level given above concerns an 8-hour work day
2. The measured values refer to emission levels, not necessarily to noise levels in the workplace. Although there is a relation between emission levels and exposure levels, it is not possible to determine with certainty if preventives are needed or are not needed. The factors affecting a current level of noise exposure during work are inter alia room characteristics and characteristics of other noise sources, e.g. number of machines and machining operations nearby. Also, the permissible exposure level value may vary depending on country. This information enables the machine's user to better identify hazards and a risk.

6.3 Electrical Diagram EG300EB\_S

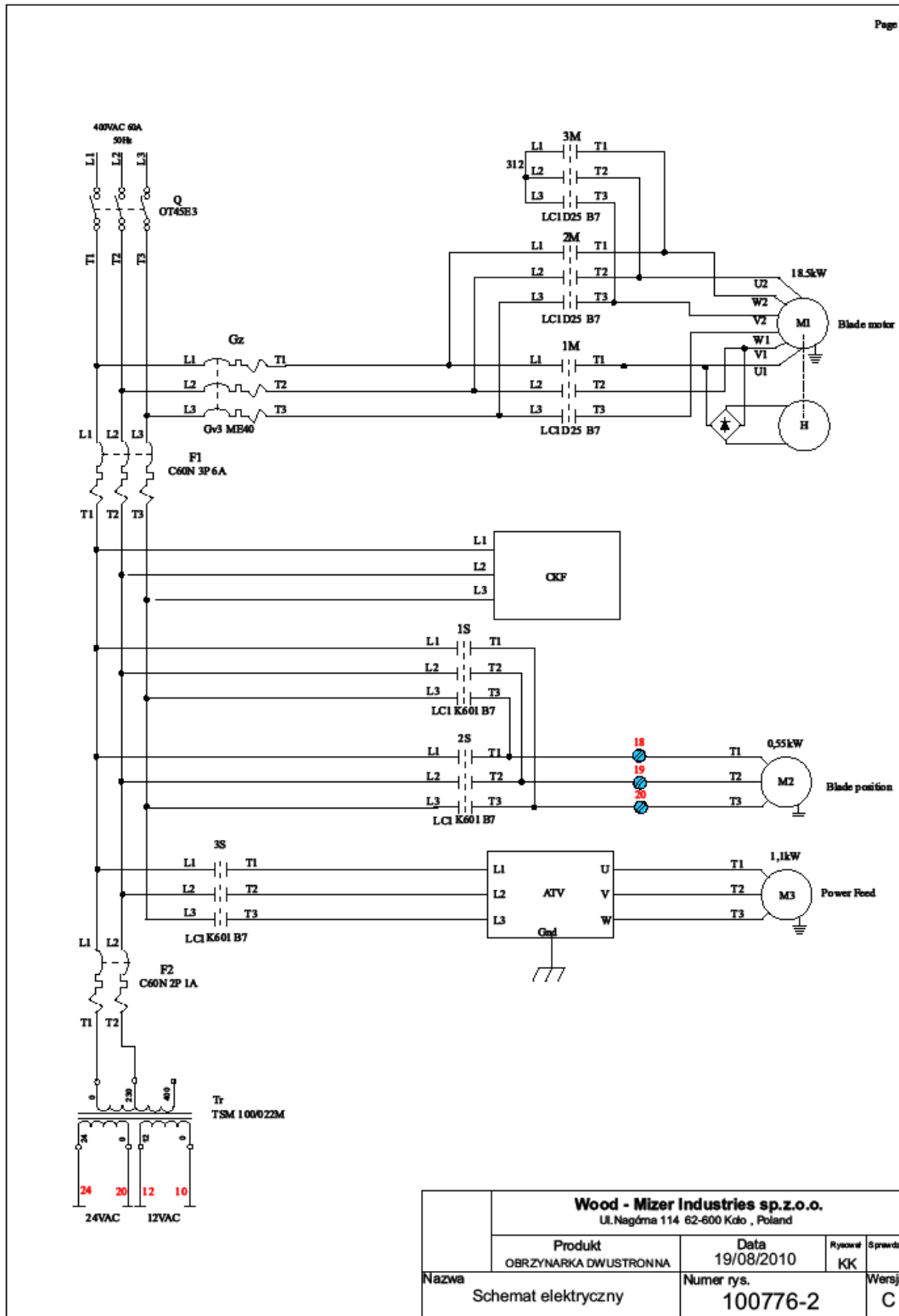

FIG. 6-1

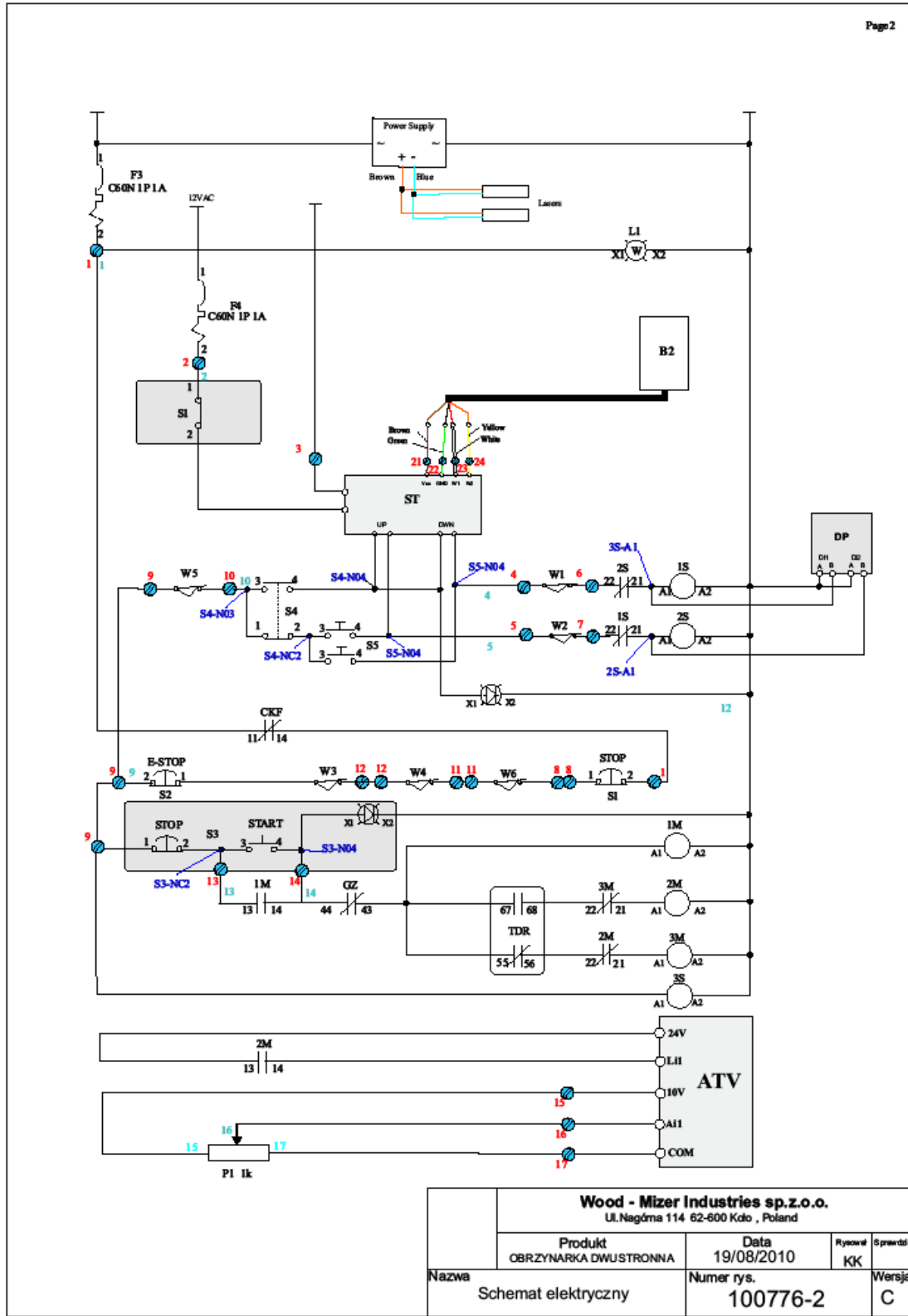

FIG. 6-1

**6.4 Electrical Diagram EG300EC**

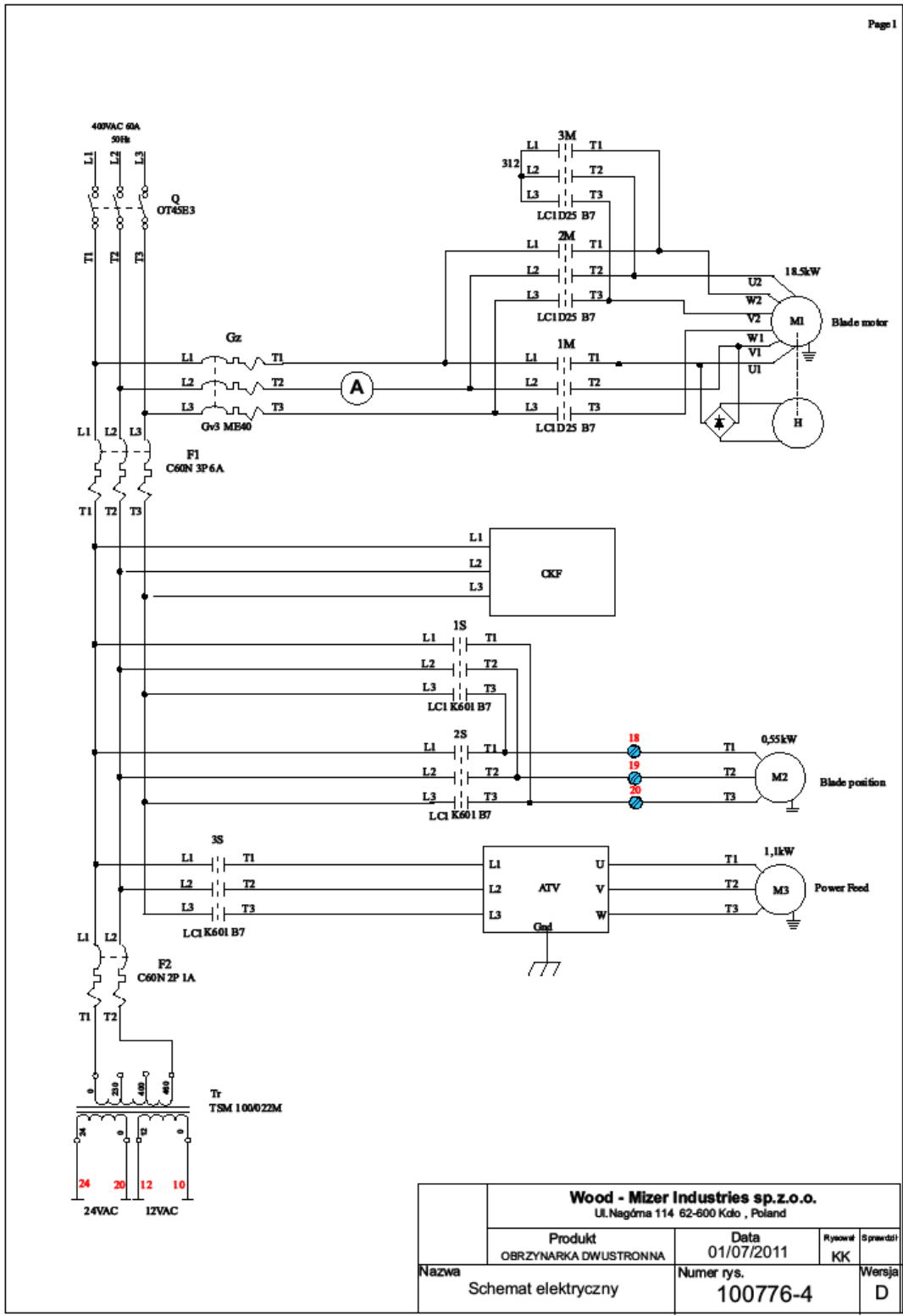

FIG. 6-1

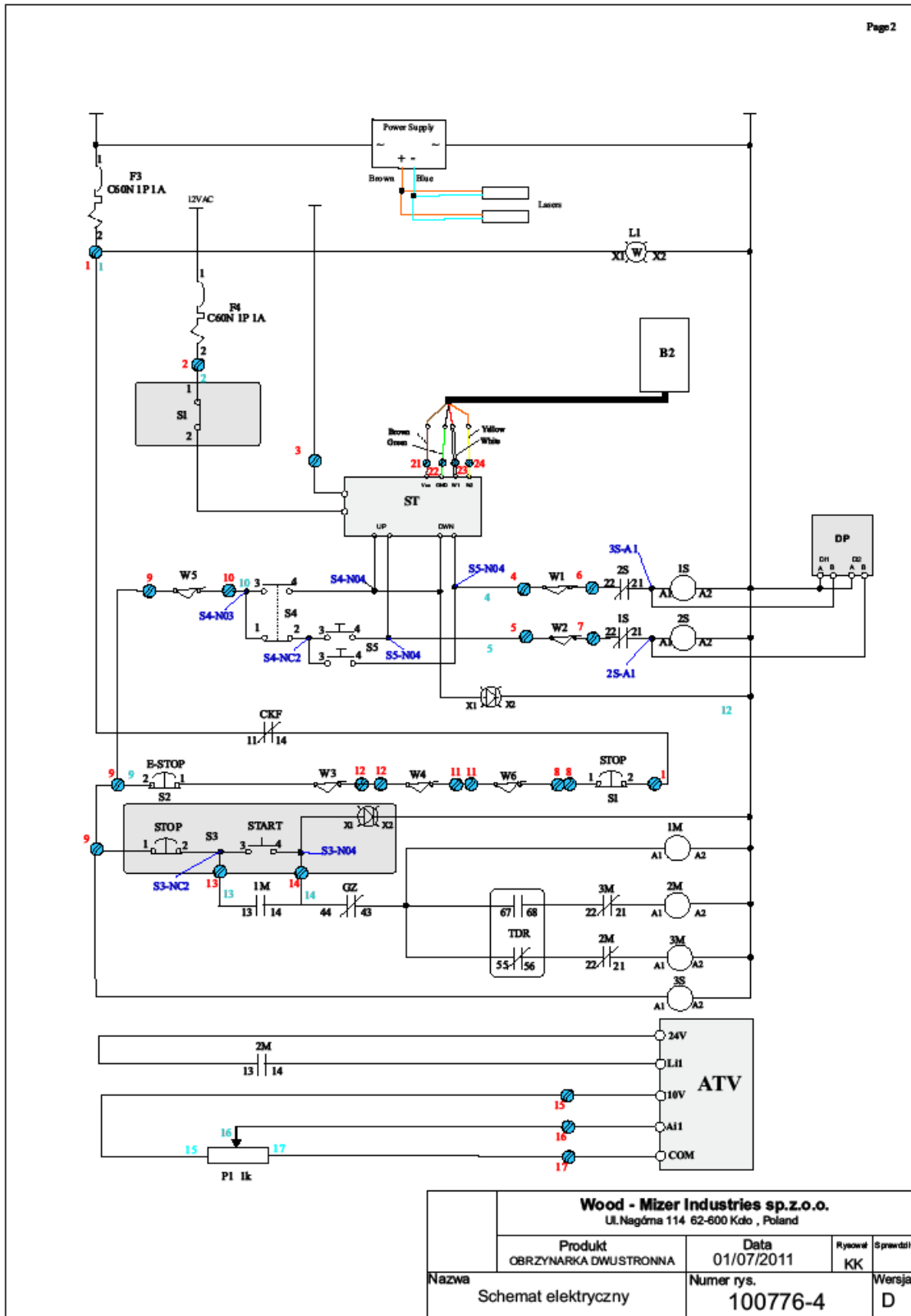

FIG. 6-1

**6.5 Electrical Diagram EG300EH**

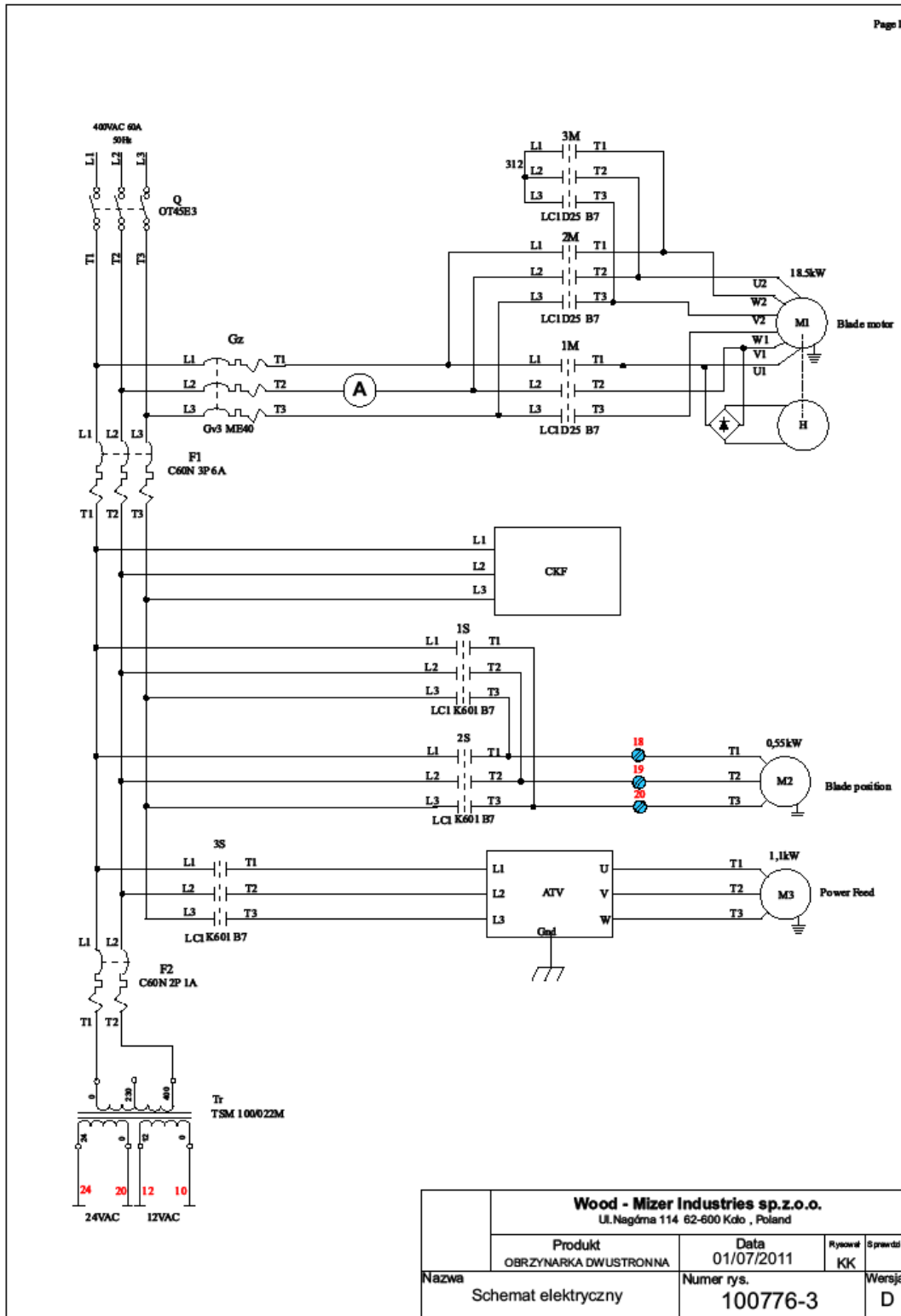

FIG. 6-1

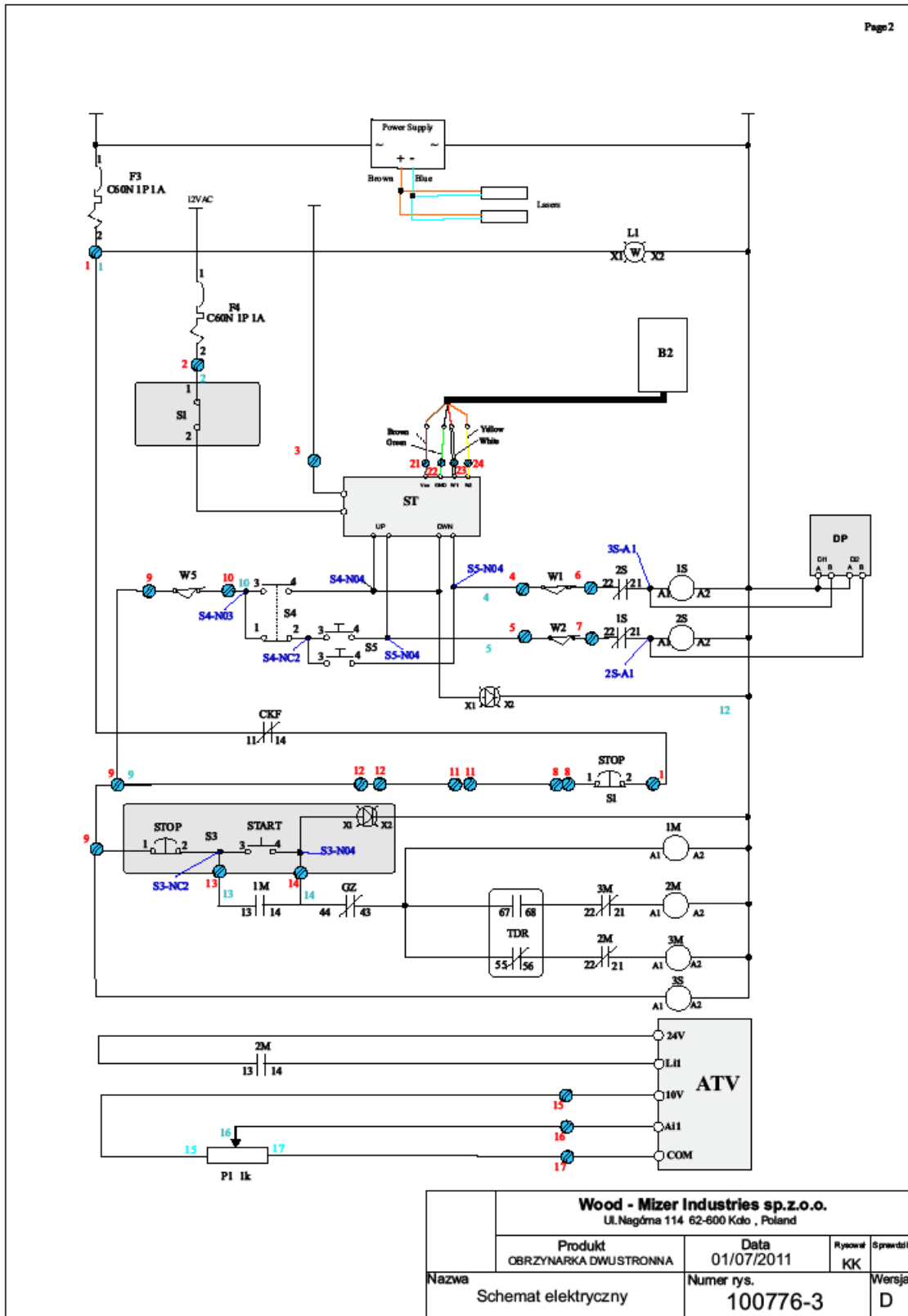

FIG. 6-1

6.6 Electrical Diagram EG300EH\_S

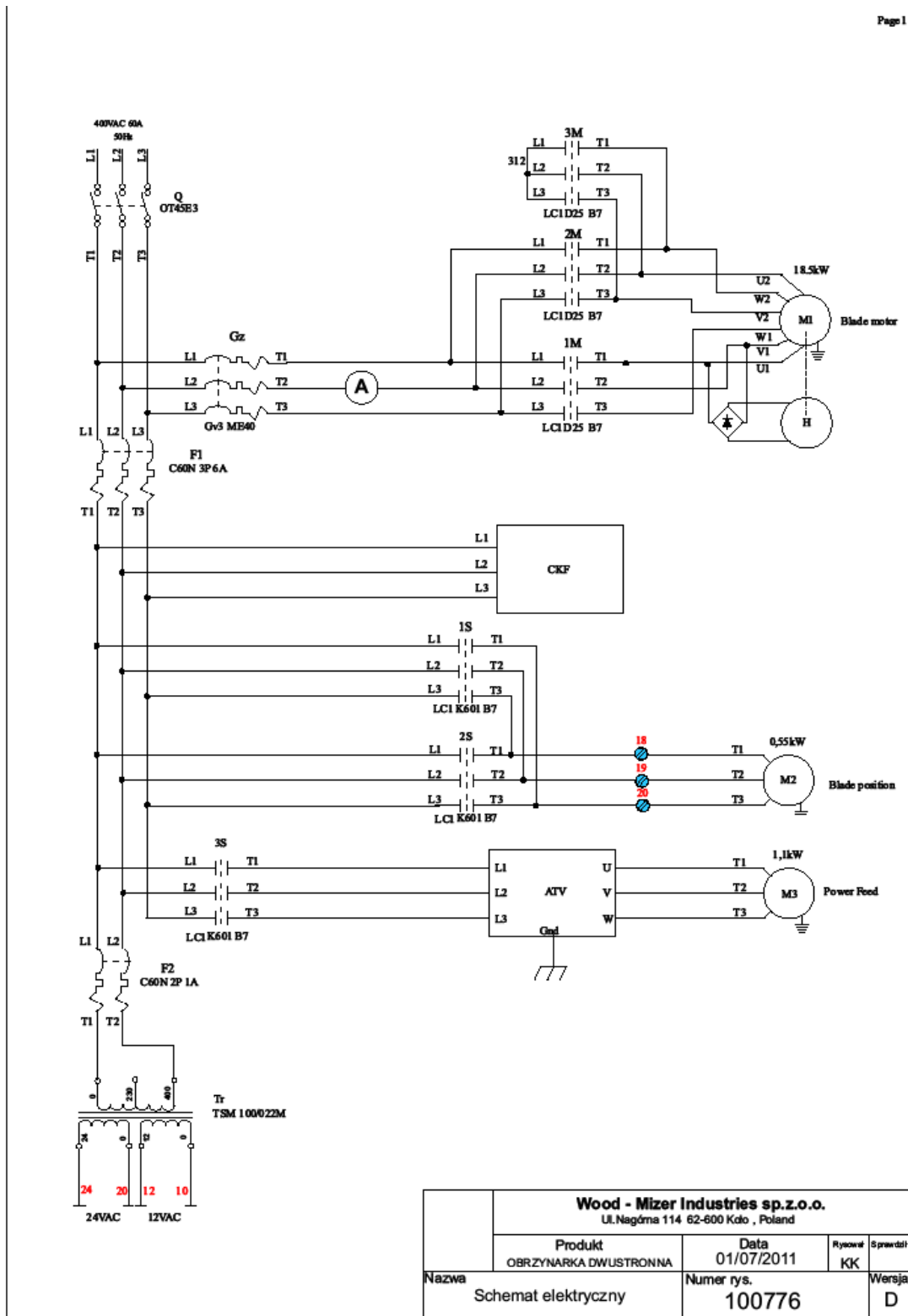
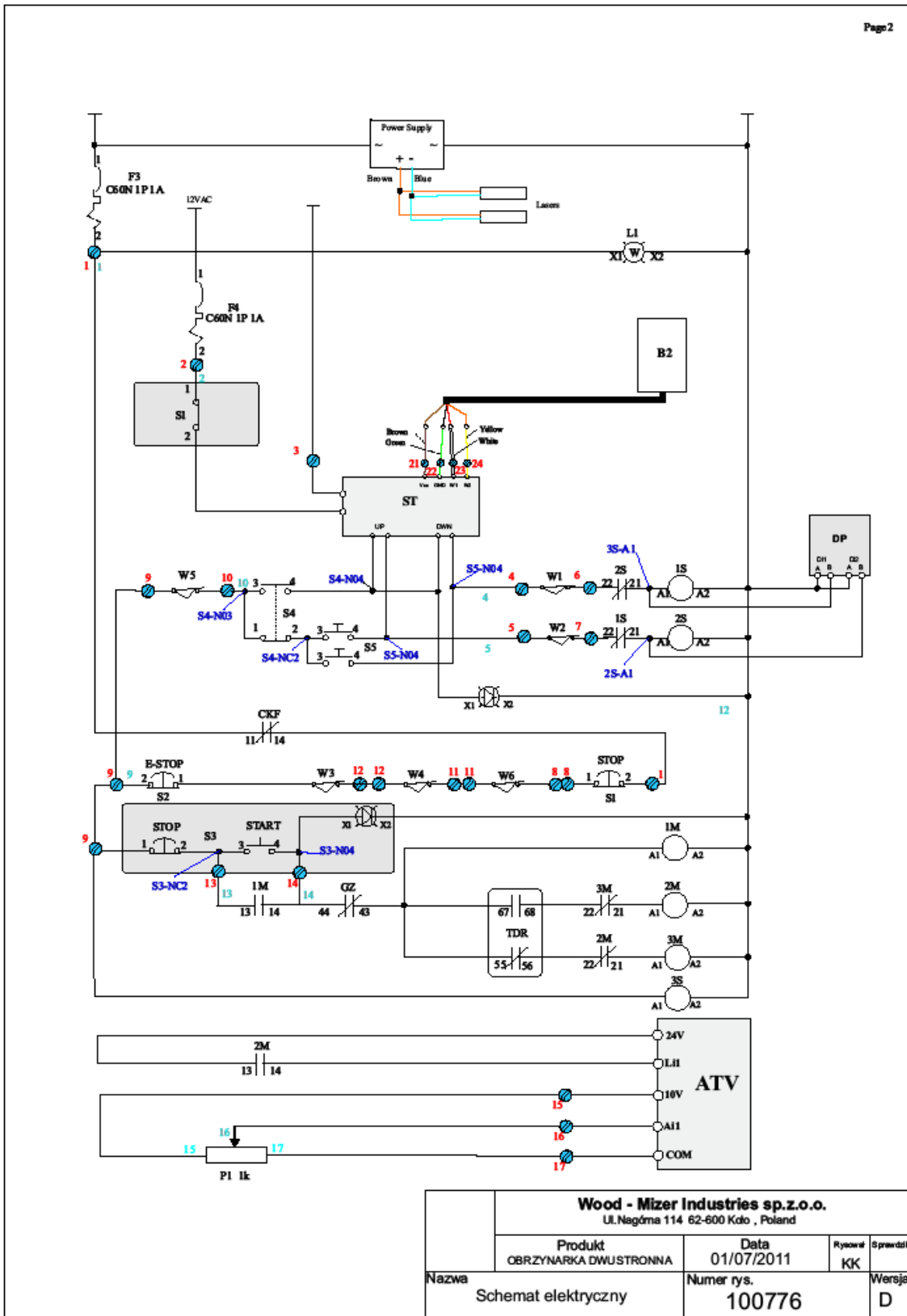

FIG. 6-1





<b>Wood - Mizer Industries sp.z.o.o.</b> Ul. Nagómska 114 62-600 Kolo, Poland			
Produkt OBRZYNIARKA DWUSTRONNA		Data 01/07/2011	Rysownik KK
Nazwa Schemat elektryczny		Numer rys. 100776	Sprawił Wersja D

FIG. 6-1

## 6.7 Electrical Component List EG300EB\_S

See Table 6-5

Symbol	Opis	Nr kat. Wood-Mizer	Producent
Q	SWITCH ABB OT63F3	503466	ABB
F1M	PRZEKAŹNIK TERMICZNY LRD35		SCHNEIDER ELECTRIC
F1	SWITCH C60N C10 24349	084317	SCHNEIDER ELECTRIC
F2	CIRCUIT BREAKER, C60N 2P C1 24331	093905	SCHNEIDER ELECTRIC
F3, F4	CIRCUIT BREAKER, C60N 1P C10 24401	088283	SCHNEIDER ELECTRIC
1M, 2M, 3M	CONTRACTOR LC1 D38 B7	503464	SCHNEIDER ELECTRIC
1S, 2S	CONTRACTOR LC1K 0601 B7	084309	SCHNEIDER ELECTRIC
3S	CONTRACTOR LC1D 09 B7	084305	SCHNEIDER ELECTRIC
M1, H	BLADE MOTOR 18.5KW, 1LA7166-2AA10-Z G26 ELECTRIC	087397-2	SIEMENS
M2	SILNIK ROZSTAWU PIŁ 0,55KW 1LA7070-6AA13		SIEMENS
M3	SILNIK NAPĘDU POSUWU 1,1KW SKH80X – 4C1	090104	BESEL
ATV	FALOWNIK ATV312HU11M3	093489	SCHNEIDER ELECTRIC
Tr	TRANSFORMATOR INDEL TSM100/022M	096917	INDEL
L1	LAMPKA KONTROLNA BIAŁA MOELLER M22	090448	MOELLER
ST	STEROWNIK POZYCJONOWANIA PIŁ SELBIT TBS01	503467	SELBIT
W1, W2	WYŁĄCZNIKI KRAŃCOWE ROZSTAWU PIŁ GLCB01A2B	086469	HONEYWELL
B2	CZUJNIK POŁOŻENIA PIŁ MSK 320	096014	SIKO
DP	DŁAWIK PRZECIWKŁÓCENIOWY DPZ-320	-	SELBIT
W3	WYŁĄCZNIK KRAŃCOWY BEZPIECZEŃSTWA GSCA01S1	088407	HONEYWELL
W4	WYŁĄCZNIK BEZPIECZEŃSTWA AZ17	094232	SCHMERSAL
W5	CZUJNIK WYKRYWANIA KŁODY GLCB01C	100910	HONEYWELL
S1	WYŁĄCZNIK BEZPIECZEŃSTWA XAL K174	E22703-P	SCHNEIDER ELECTRIC
S2	WYŁĄCZNIK BEZPIECZEŃSTWA XB4BS542	086556	SCHNEIDER ELECTRIC
S3	PRZYCISK START-STOP M22	090452	MOELLER
TDR	BLOK OPÓŹNIAJĄCY ŁAD S2	084037	SCHNEIDER ELECTRIC
P1	SILNIK NAPĘDU PIŁ 18,5KW 1LA7166-2AA10-Z G26	E20519	CLAROSTAT
CKF	SILNIK ROZSTAWU PIŁ 0,55KW 1LA7070-6AA13	501016	FINDER

TABLE 6-5

## 6.8 Electrical Component List EG300EC

See Table 6-6

Symbol	Opis	Nr kat. Wood-Mizer	Producent
Q	Switch ABB OT40F3	502312	ABB
Gz	Wyłącznik silnikowy GV3 P40 SCHNEIDER	090436	SCHNEIDER ELECTRIC
F1	Wyłącznik modułowy C60N 3P C6	091554	SCHNEIDER ELECTRIC
F2	Wyłącznik modułowy C60N 2P C1	093905	SCHNEIDER ELECTRIC
F3, F4	Wyłącznik modułowy C60N 1P C1	088283	SCHNEIDER ELECTRIC
1M, 2M, 3M	Stycznik LC1 D25 B7	090923	SCHNEIDER ELECTRIC
1S, 2S, 3S	Stycznik LC1 0601 B7	084309	SCHNEIDER ELECTRIC
M1, H	Silnik napędu pił 18,5kW 1LA7166-2AA60-Z G26+C01 Silnik napędu pił 15kW 1LA7164-2AA60-Z G26+C01	087397 087396	SIEMENS
M2	Silnik rozstawu pił 0,55kW 1LA7070-6AA13		SIEMENS
M3	Silnik napędu posuwu 1,1kW SKh80X – 4C1	090104	BESEL
ATV	Falownik ATV31HU11N4	093488	SCHNEIDER ELECTRIC
Tr	Transformator INDEL TSM100/022M	096917	INDEL
L1	Lampka kontrolna biała MOELLER M22	090448	MOELLER
ST	Sterownik pozycjonowania pił SELBIT TBS01	503467	SELBIT
W1, W2	Wyłączniki krańcowe rozstawu pił GLCB01A2B	086469	HONEYWELL
B2	Czujnik położenia pił MSK 320	096014	SIKO
DP	Dławik przeciwwzakłócenowy DPZ-320	-	SELBIT
W3	Wyłącznik krańcowy bezpieczeństwa GSCA01S1	088407	HONEYWELL
W4	Wyłącznik bezpieczeństwa AZ17	094232	SCHMERSAL
W5	Czujnik wykrywania kłody GLCB01C	100910	HONEYWELL
S1	Wyłącznik bezpieczeństwa XAL K174	E22703-P	SCHNEIDER ELECTRIC
S2	Wyłącznik bezpieczeństwa XB4BS542	086556	SCHNEIDER ELECTRIC
S3	Przycisk START-STOP M22	090452	MOELLER
TDR	Blok opóźniający LAD S2	084037	SCHNEIDER ELECTRIC
P1	Potencjometr 1k/1W	E20519	CLAROSTAT
CKF	Przełącznik nadzorczy 72.31.8.400.0000	501016	FINDER
A	Ammeter EQB72 30/60A for E20 Electric Motor	505372	GOSSSEN
A	Ammeter EQB72 40/80A for E25 Electric Motor	505373	GOSSSEN

TABLE 6-6

## 6.9 Electrical Component List EG300EH\_S

See Table 6-7

Symbol	Opis	Nr kat. Wood-Mizer	Producent
Q	Switch ABB OT40F3	502312	ABB
Gz	Wyłącznik silnikowy GV3 P40 SCHNEIDER	090436	SCHNEIDER ELECTRIC
F1	Wyłącznik modułowy C60N 3P C6	091554	SCHNEIDER ELECTRIC
F2	Wyłącznik modułowy C60N 2P C1	093905	SCHNEIDER ELECTRIC
F3, F4	Wyłącznik modułowy C60N 1P C1	088283	SCHNEIDER ELECTRIC
1M, 2M, 3M	Stycznik LC1 D25 B7	090923	SCHNEIDER ELECTRIC
1S, 2S, 3S	Stycznik LC1 0601 B7	084309	SCHNEIDER ELECTRIC
M1, H	Silnik napędu pił 18,5kW 1LA7166-2AA60-Z G26+C01 Silnik napędu pił 15kW 1LA7164-2AA60-Z G26+C01	087397 087396	SIEMENS
M2	Silnik rozstawu pił 0,55kW 1LA7070-6AA13		SIEMENS
M3	Silnik napędu posuwu 1,1kW SKh80X – 4C1	090104	BESEL
ATV	Falownik ATV31HU11N4	093488	SCHNEIDER ELECTRIC
Tr	Transformator INDEL TSM100/022M	096917	INDEL
L1	Lampka kontrolna biała MOELLER M22	090448	MOELLER
ST	Sterownik pozycjonowania pił SELBIT TBS01	503467	SELBIT
W1, W2	Wyłączniki krańcowe rozstawu pił GLCB01A2B	086469	HONEYWELL
B2	Czujnik położenia pił MSK 320	096014	SIKO
DP	Dławik przeciwzakłóceń DPZ-320	-	SELBIT
W3	Wyłącznik krańcowy bezpieczeństwa GSCA01S1	088407	HONEYWELL
W4	Wyłącznik bezpieczeństwa AZ17	094232	SCHMERSAL
W5	Czujnik wykrywania kłody GLCB01C	100910	HONEYWELL
S1	Wyłącznik bezpieczeństwa XAL K174	E22703-P	SCHNEIDER ELECTRIC
S2	Wyłącznik bezpieczeństwa XB4BS542	086556	SCHNEIDER ELECTRIC
S3	Przycisk START-STOP M22	090452	MOELLER
TDR	Blok opóźniający LAD S2	084037	SCHNEIDER ELECTRIC
P1	Potencjometr 1k/1W	E20519	CLAROSTAT
CKF	Przełącznik nadzorczy 72.31.8.400.0000	501016	FINDER
A	Ammeter EQB72 30/60A for E20 Electric Motor	505372	GOSSSEN
A	Ammeter EQB72 40/80A for E25 Electric Motor	505373	GOSSSEN

TABLE 6-7

## 6.10 Dust Extractor Specifications

See **Table 6-8** Specifications of the dust extractors used on the Edger are listed below.

<b>Airflow</b>	1200 m <sup>3</sup> /h
<b>Inlet diameter</b>	150 mm
<b>Motor power</b>	1,5 kW
<b>Number of sacks</b>	2 pcs
<b>Sack capacity</b>	0.25 m <sup>3</sup>
<b>Weight</b>	110 kg
<b>Recommended conveying air velocity in the duct</b>	20 m/s

**TABLE 6-8**

## SECTION 7 PARTS

### 7.1 How To Use The Parts List

- Go to the appropriate section and locate the part in the illustration.
- Use the number pointing to the part to locate the correct part number and description in the table.
- Parts shown indented under another part are included with that part.
- Parts marked with a diamond (◆) are only available in the assembly listed above the part.

See the sample table below. Sample Part #A01111 includes part F02222-2 and subassembly A03333. Subassembly A03333 includes part S04444-4 and subassembly K05555. The diamond (◆) indicates that S04444-4 is not available except in subassembly A03333. Subassembly K05555 includes parts M06666 and F07777-77. The diamond (◆) indicates M06666 is not available except in subassembly K05555.

7.1 Sample Assembly				
REF	DESCRIPTION (◆ Indicates Parts Available In Assemblies Only)	PART #	QTY.	
	<b>SAMPLE ASSEMBLY, COMPLETE</b> (Includes All Indented Parts Below)	A01111	1	
1	Sample Part	F02222-22	1	
2	Sample Subassembly (Includes All Indented Parts Below)	A03333	1	
	Sample Part (Indicates Part Is Only Available With A03333)	S04444-4	1	◆
3	Sample Subassembly (Includes All Indented Parts Below)	K05555	1	
	Sample Part (Indicates Part Is Only Available With K05555)	M06666	2	◆
4	Sample Part	F07777-77	1	

#### To Order Parts:

From the Europe, call **+48 26 26 000** to order parts. Have your customer number, VIN, and part numbers ready when you call. From other international locations, contact the Wood-Mizer distributor in your area for parts.

## 7.2 Anti-Kickback Assembly & Press Roller

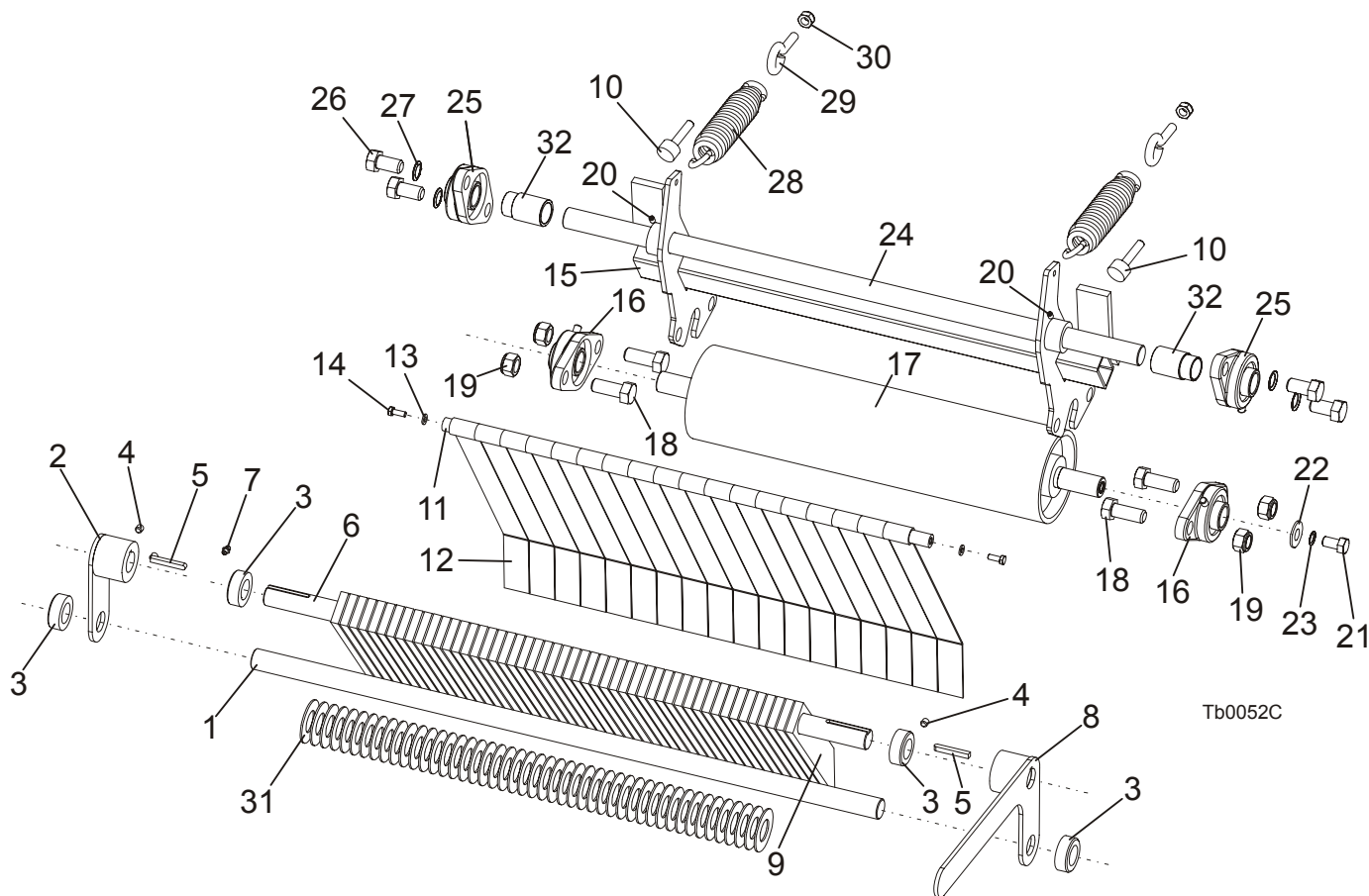

Tb0052C

REF	DESCRIPTION (◆ Indicates Parts Available In Assemblies Only)	PART #	QTY.
1	ROD, 25X810 HANDLE MOUNTING	089089-1	1
2	PLATE WELDMENT, ANTI-KICKBACK	089087-1	1
3	RING, 25 ZINC STOPPING LIGHT TYPE	F81039-4	4
4	SCREW, M8X8-33H HEX SOCKET SET FLAT POINT ZINC	F81014-1	4
5	KEY, 1/4" X 1 11/16"	089229	2
6	SHAFT, ANTI-KICKBACK FINGER	089088-1	1
7	FITTING, M6 "A" TYPE STRAIGHT GREASE	086280	1
8	HANDLE WELDMENT, ANTI-KICKBACK RELEASE	089086-1	1
9	FINGER, ANTI-KICKBACK	089079-1	51
10	BUMPER, RUBBER	089147	2
11	ROD, SAWDUST SHIELD	089236-1	1
12	PLATE, SAWDUST SHIELD ZINC-PLATED	089234-1	18
13	WASHER, 6.4 FLAT ZINC	F81053-1	2
14	BOLT, M6 x 16 8.8 HEX HEAD FULL THREAD ZINC	F81001-15	2
	<b>PRESS ROLLER ASSEMBLY</b>	089156	1
15	PIVOT WELDMENT, PRESS ROLLER	089063-1	1
16	BEARING, UCFL 205 W/HOUSING	089124	2
17	ROLLER, PRESS	503170-1	1
18	BOLT, M16X40-8.8 HEX HEAD FULL THREAD ZINC	F81006-13	4

# 7

## PARTS

### Anti-Kickback Assembly & Press Roller

19	NUT, M16-8 HEX NYLON ZINC LOCK	F81036-2	4	
20	SCREW, M6X8 45H HEX SOCKET SET CONE POINT	F81013-1	2	
21	BOLT, M10-1.5X25MM HH GR8.8	F81003-11	1	
22	WASHER, 10.5 ZINC FLAT SPECIAL	F81055-6	1	
23	WASHER, 791 M10/10.5 SPRING LOCK RIBBED	F81055-7	1	
24	ROD, PIVOT	089064	1	
25	BEARING, UCFL 205 W/HOUSING	089124	2	
26	BOLT, M16X30 8.8 HEX HEAD FULL THREAD ZINC	F81006-36	4	
27	WASHER, 791 M16/17 RIBBED LOCK	F81056-13	4	
28	SPRING, PRESS ROLLER ZINC-PLATED	089689-1	2	
29	TENSIONER, ZINC-PLATED	089153-1	2	
30	NUT, M10-8-B HEX NYLON ZINC LOCK	F81033-1	2	
31	WASHER, SPECIAL - ZINC	089157-1	47	
32	BUSHING, 33.7x26x55 PRESS ROLLER SPACER ZINC	504257-1	2	



### 7.3 Blades Drive Shaft Assembly

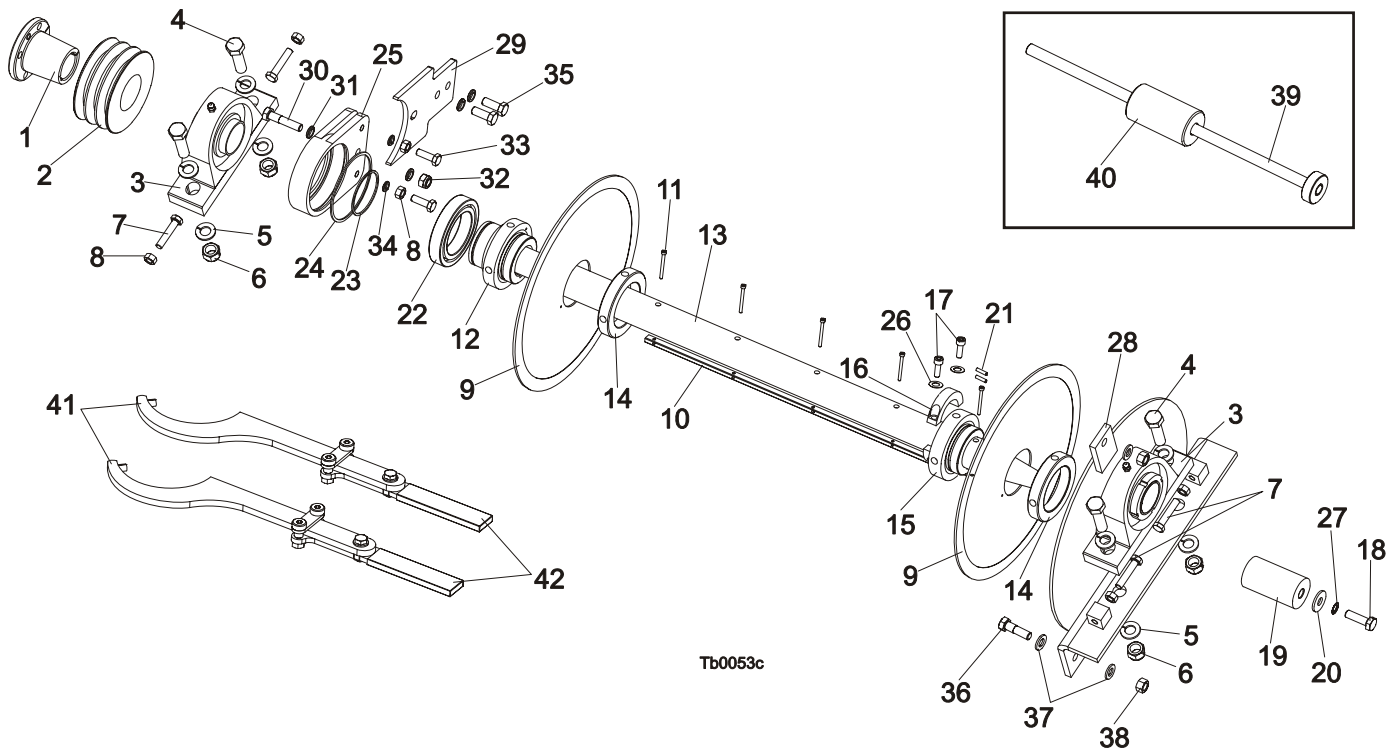

REF	DESCRIPTION (◆ Indicates Parts Available In Assemblies Only)	PART #	QTY.
1	BUSHING, FLANGED (E25 MOTOR)	085714	1
2	PULLEY, 15/18.5 KW EA25 MOTOR	085671	1
3	BEARING, UKP211D1 NSK	101109	2
	BUSHING, H2311X PULLED	503075	2
4	BOLT, M16 X 60 8.8 HEX HEAD FULL THREAD ZINC	F81006-12	6
5	WASHER, 16.3 SPLIT LOCK ZINC	F81058-2	12
6	NUT, M16-8 HEX NYLON ZINC LOCK	F81036-2	6
7	BOLT, M10x50-8.8 HEX HEAD FULL THRD ZINC	F81003-4	4
8	NUT, M10-8-B HEX ZINC	F81033-3	6
9	BLADE, PI-510 350x3,9/2,6/76 Z-24+4GM	089144	2
	COMPLETE BLADE DRIVE SHAFT	100716	1
10	KEY, 12X8X585 SPECIAL	089040	1
11	SCREW, M4X50-8.8 HEX SOCKET HEAD CAP ZINC	F81011-32	5
12	ARBOR, MOVING BLADE PTD	089093-1	1
13	SHAFT, CIRCULAR SAW BLADE CHROMIUM-PLATED	101005	1
14	NUT, BLADE RETAINER PTD (EE15)	089092-1	2
15	ARBOR, FIXED BLADE PTD	089091-1	1
16	WRAP, EDGER	089116-1	1
17	SCREW, M8x25-8.8 HEX SOCKET HEAD CAP ZINC	F81002-21	2
18	BOLT, M12x40-8.8 HEX HEAD FULL THREAD ZINC	F81004-4	1
19	BUSHING, LOCKING	094416-1	1
20	WASHER, 13 FLAT SPECIAL	F81056-12	1
21	PIN,H 3m6x20 DIN6325 HRC60 ROLL	F81048-2	2
22	BEARING, 6014 2RS1 CX BALL	089164	1

23	RING, Z70 OUTSIDE RETAINING	089165	1	
24	RING, W110 INSIDE RETAINING	089166	1	
25	BLOCK, BLADE SLIDE	500527-1	1	
26	WASHER, 8.2 SPRONG LOCK ZINC	F81054-4	2	
27	WASHER, 792 M12/13 SPRING LOCK RIBBED	F81056-15	1	
28	<b>COVER, SIDE COMPLETE</b>	500109-1	1	
29	<b>PLATE, BLADE SLIDE ZINC-PLATED</b>	500549	1	
30	<b>BOLT, M12x55-8.8 HEX HEAD FULL THREAD ZINC</b>	F81004-43	1	
31	<b>WASHER, 12.2 DIN 127 A2 SPLIT LOCK STAINLESS STEEL</b>	F81056-8	4	
32	<b>NUT, M12-8 HEX NYLON ZINC LOCK</b>	F81034-2	1	
33	<b>BOLT, M10x30-5.8 HEX HEAD FULL THREAD ZINC</b>	F81003-2	2	
34	<b>WASHER, 10.2 SPLIT LOCK ZINC</b>	F81055-2	2	
35	<b>BOLT, M12X30-8.8 HEX HEAD FULL THREAD ZINC</b>	F81004-22	2	
36	<b>BOLT, M12x40-8.8 HEX HEAD ZINC</b>	F81004-1	2	
37	<b>WASHER, 13 FLAT ZINC</b>	F81056-1	4	
38	<b>NUT, M12-8-B HEX ZINC</b>	F81034-1	2	
	<b>BEARING PULLER</b>	094626	1	
39	PULLER, BEARING ZINC-PLATED	094627-1	1	
40	BUSHING, STRIKING ZINC-PLATED	094628-1	1	
41	<b>WRENCH, #628500/110/115 EDGER</b>	094641	2	
42	<b>EXTENSION, #628500/110/115 EDGER WRENCH</b>	504356	2	

## 7.4 Spacer Mounting Kit (Optional)

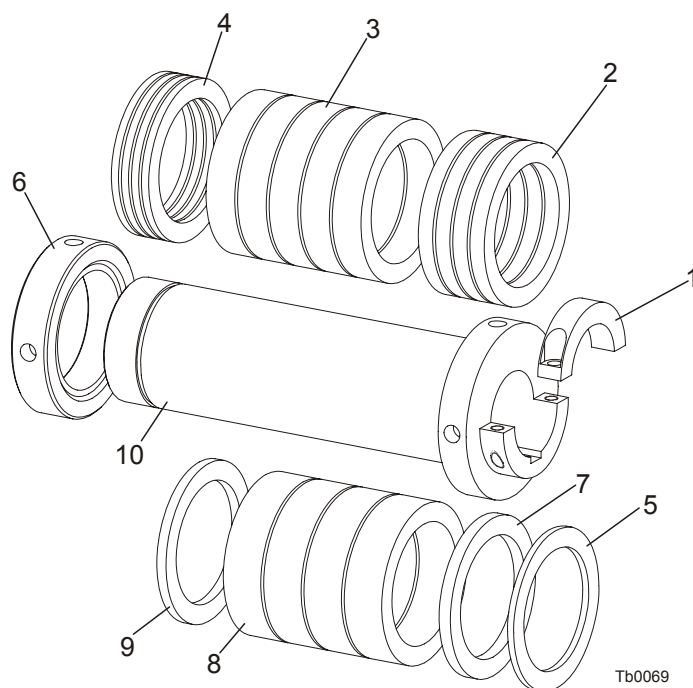

LP.	OPIS (◆ wskazuje części dostępne jedynie w zespołach )	NUMER KAT.	SZT.
	<b>MOUNTING KIT FOR 5 BLADES</b>	093328 <sup>1</sup>	1
1	COLLAR, LOCKING EDGER	089116	1
2	RING, SPACER (FOR 5 BLADES)	090967-1	4
3	SPACER (FOR 5 BLADES)	090968-1	5
4	SPACER, 5MM THICK (FOR 5 BLADES)	090971-1	4
5	SPACER, 4.2MM THICK (FOR 5 BLADES)	091135-1	1
6	NUT, LOCKING ZINC-PLATED (FOR 5 BLADES)	091493-1	1
7	SPACER, 7MM THICK (FOR 5 BLADES)	091509-1	1
8	SPACER, 26.1MM THICK (FOR 5 BLADES)	091510-1	4
9	SPACER, 6.4MM THICK (FOR 5 BLADES)	091511-1	1
10	BUSHING, BLADE MOUNT - LONG	092961-1	1

<sup>1</sup> It is possible to mount maksimum 3 blades as optional equipment.

### 7.5 Covers

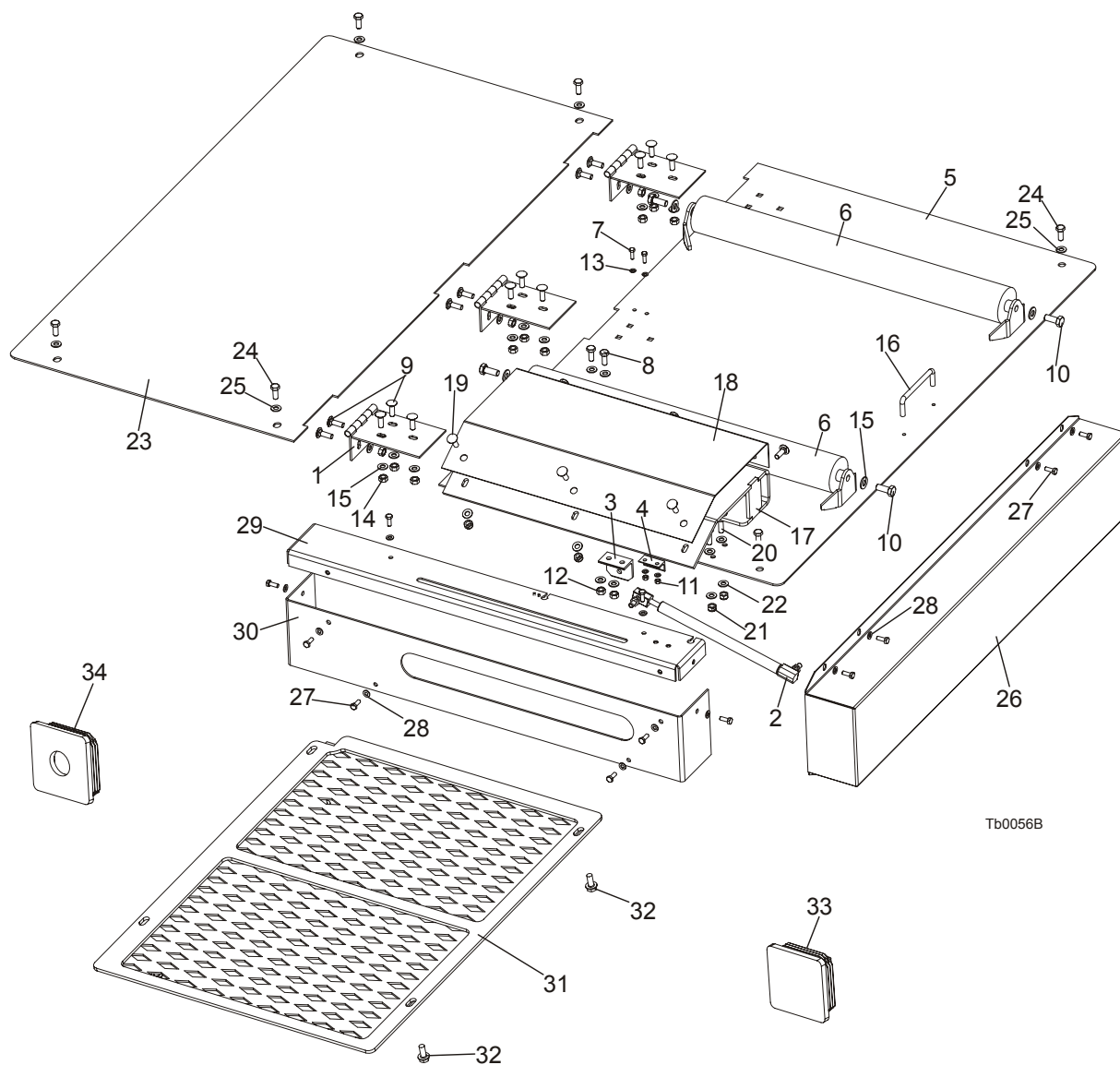

Tb0056B

REF	DESCRIPTION (◆ Indicates Parts Available In Assemblies Only)	PART #	QTY.
	<b>COVER, COMPLETE RIGHT</b>	101119	1
1	HINGE, COMPLETE	038136-1	3
2	SPRING, 340N GAS COMPLETE	089212	1
3	BRACKET, GAS SPRING	089213-1	1
4	BRACKET, SAFETY SWITCH CAM	089225-1	1
5	COVER, RIGHT	100707-1	1
6	ROLLER, 63.5/20x590	501090-1	2
7	BOLT, M5x16-5.8 HEX HEAD FULL THREAD ZINC	F81000-51	2
8	BOLT, M8X20-5.8 HEX HEAD FULL THREAD ZINC	F81002-1	2
9	BOLT, M8 X 20 MUSHROOM HEAD SQUARE NECK ZINC	F81002-11	15
10	BOLT, M10X25-8.8 HEX HEAD FULL THREAD ZINC	F81003-11	4
11	NUT, M5-8 HEX ZINC	F81030-1	2
12	NUT, M8-8-B HEX ZINC	F81032-1	18

13	WASHER, 5.3 FLAT ZINC	F81052-1	4	
14	WASHER, 8.4 FLAT ZINC	F81054-1	20	
15	WASHER, 10.5 FLAT ZINC	F81055-1	4	
16	HANDLE, BLADE COVER	P08065	1	
	<b>GUARD, EDGER LASERS - COMPLETE</b>	500755	1	
17	GUARD, EDGER LASERS	500753-1	1	
18	PLATE, LASERS GUARD	500754	1	
19	BOLT, M8 X 20 MUSHROOM HEAD SQUARE NECK	F81002-11	6	
20	BOLT, M8x25-8.8-B HEX HEAD FULL THREAD ZINC	F81002-5	4	
21	NUT, M8-8-B HEX NYLON ZINC LOCK	F81032-2	10	
22	WASHER, 8.4 FLAT ZINC	F81054-1	14	
23	<b>COVER, RIGHT HINGED</b>	089108-1	1	
24	<b>BOLT, M8x20-8.8-B HEX HEAD FULL THREAD ZINC</b>	F81002-4	6	
25	<b>WASHER, 8.4 FLAT ZINC</b>	F81054-1	6	
26	<b>GUARD, EDGER SHAFTS</b>	101112-1	1	
27	<b>BOLT, M6 x 16 8.8 HEX HEAD FULL THREAD ZINC</b>	F81001-15	12	
28	<b>WASHER, 6.4 FLAT ZINC</b>	F81053-1	12	
29	<b>COVER, TOP</b>	500745-1	1	
30	<b>GUARD, EDGER LASERS</b>	500743-1	1	
31	<b>COVER, EDGER DRIVE</b>	501093-1	1	
32	<b>BOLT, 5/16-18x3/4 SELF TAP</b>	F05015-30	4	
33	<b>CAP, EDGER FRAME</b>	089644	2	
34	<b>CAP, EDGER W/HOLE</b>	501095	2	

## 7.6 Infeed Roller Assemblies & Roller Chains

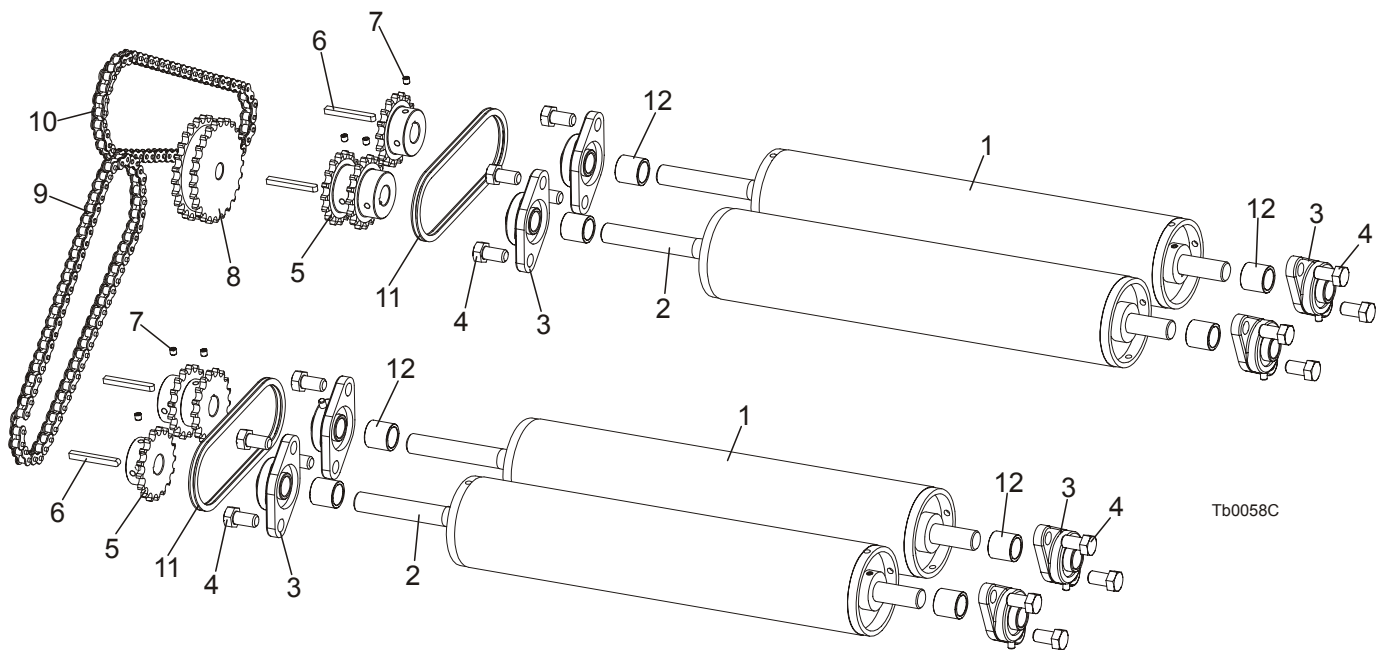

Tb0058C

REF	DESCRIPTION (◆ Indicates Parts Available In Assemblies Only)	PART #	QTY.
1	ROLLER, INFEEED COMPLETE	089138	4
2	SHAFT, INFEEED ROLLER	089372	4
3	BEARING, UCFL 205 W/HOUSING	089124	8
4	BOLT, M16X30 8.8 HEX HEAD FULL THREAD ZINC	F81006-36	16
5	SPROCKET, ZINC-PLATED	089098-1	6
6	KEY, AB 8X7X70 PARALLEL	089231	4
7	SCREW, M8X8 45H HEX SOCKET SET FLAT POINT	F81014-1	6
8	SPROCKET, 10B-1 F03212 Z=25 ZINC-PLATED	101124	1
9	CHAIN, 10B 1-64PZ EDGER ROLLER DRIVE	101420	1
10	CHAIN, II (10B I-59) EDGER ROLLER DRIVE	501455	1
11	CHAIN, 10B-37WZ+LINK 10BWZ, ROLLER-TO-ROLLER	089177	2
12	BUSHING, 33.7x26x31 INFEEED ROLLER SPACER ZINC	504256-1	8

## 7.7 Board Guide Fence

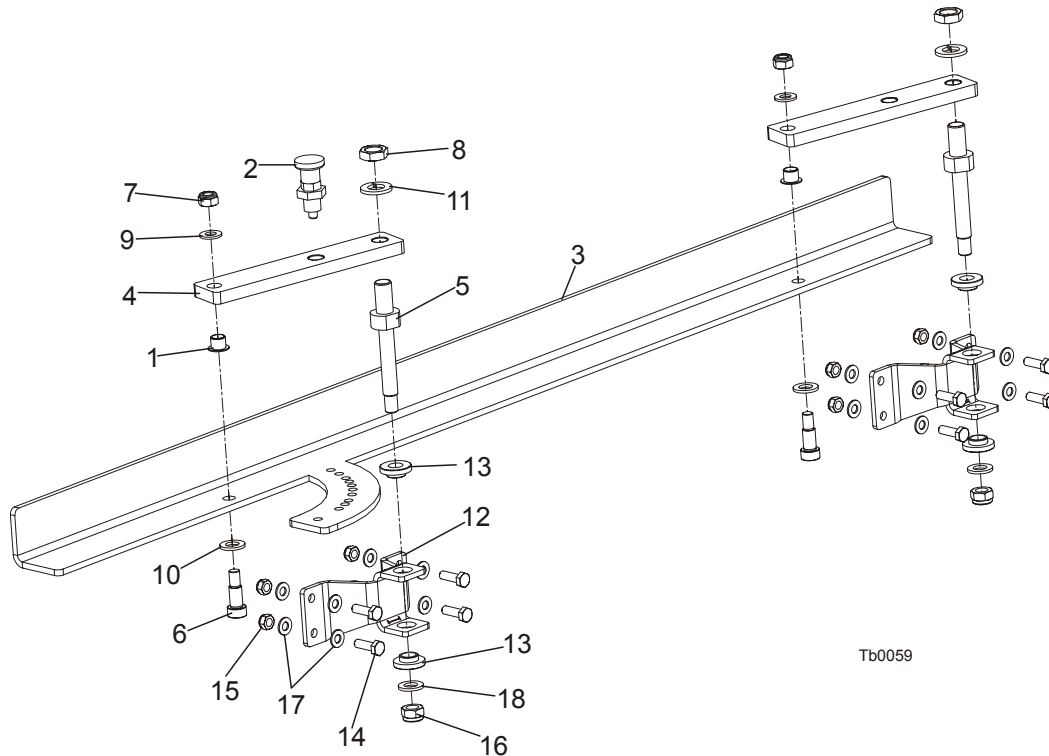

REF	DESCRIPTION (◆ Indicates Parts Available In Assemblies Only)	PART #	QTY.
	<b>COMPLETE BOARD GUIDE FENCE</b>	101100	1
	<b>FENCE, BOARD GUIDE</b>	101020	1
1	BUSHING, XFM-1214-12 FLANGED	088934	2
2	PIN, DETENT	090197	1
3	FENCE, GUIDE	101097-1	1
4	BAR, GUIDE FENCE ARM	101098-1	2
5	PIN, GUIDE FENCE ARM ZINC-PLATED	101099-1	2
6	BOLT, 12/M10x20 12.9 ISO7379 SHOULDER	F81003-68	2
7	NUT, M10-8-B HEX NYLON ZINC LOCK	F81033-1	2
8	NUT, M16X1.5-08-B HEX THIN ZINC	F81036-6	2
9	WASHER, 10.5 FLAT ZINC	F81055-1	2
10	WASHER, 13 FLAT ZINC	F81056-1	2
11	WASHER, 16.3 SPLIT LOCK ZINC	F81058-2	2
12	BRACKET, BOARD GUIDE FENCE	101102-1	2
13	BUSHING, BOARD GUIDE FENCE	101411	4
14	BOLT, M8x25-8.8-B HEX HEAD FULL THREAD ZINC	F81002-5	8
15	NUT, M8-8-B HEX NYLON ZINC LOCK	F81032-2	8
16	NUT, M12-8 HEX NYLON ZINC LOCK	F81034-2	2
17	WASHER, 8.4 FLAT ZINC	F81054-1	16
18	WASHER, 13 FLAT ZINC	F81056-1	2

### 7.8 Motor Assembly, Control Box, Electric Box, Safety Switches

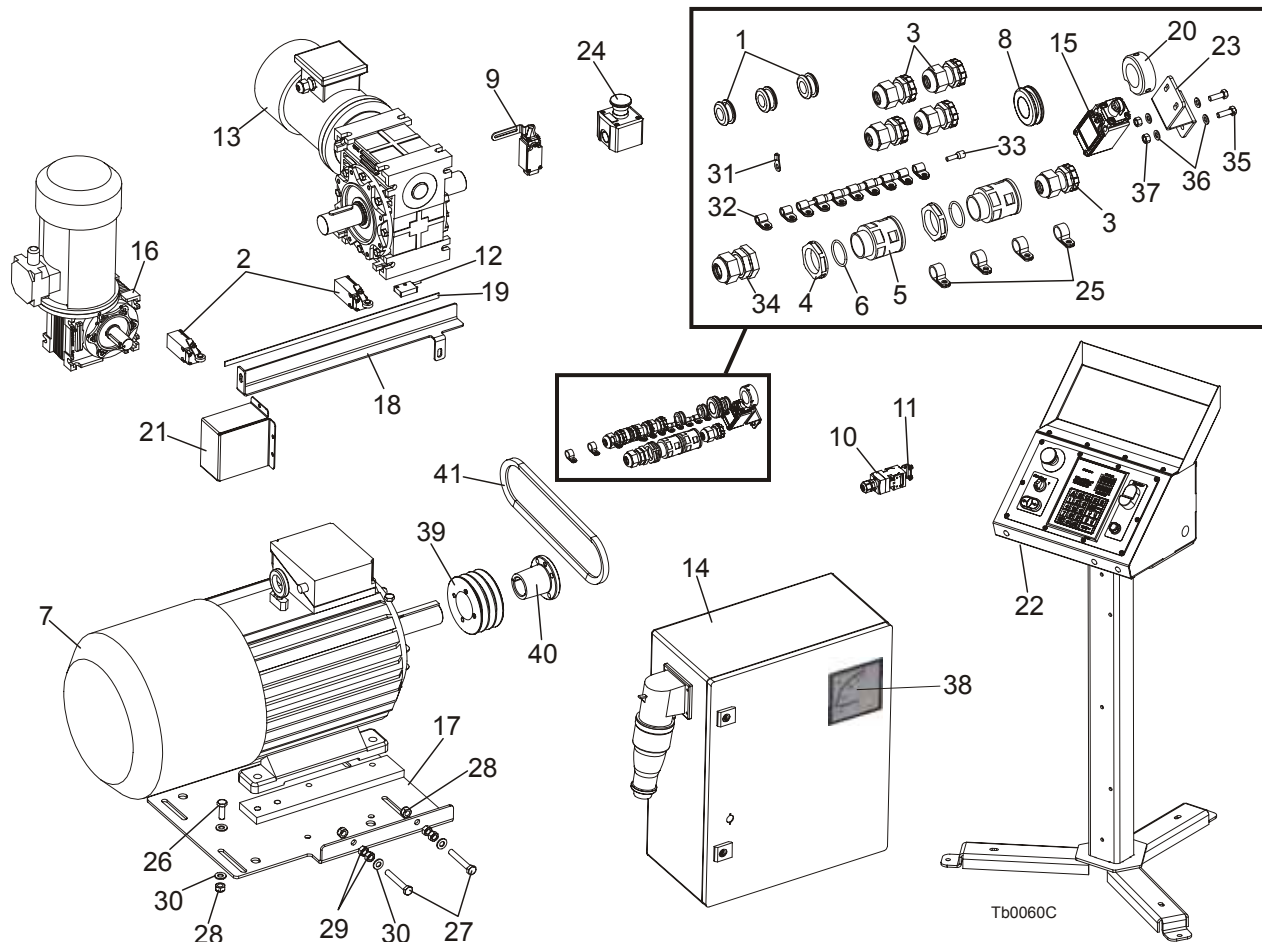

REF	DESCRIPTION (◆ Indicates Parts Available In Assemblies Only)	PART #	QTY.
	<b>EDGER MOTOR ASSEMBLY 15KW E20</b>	500635	1
	<b>EDGER MOTOR ASSEMBLY 18.5KW E25</b>	500034	1
1	GROMMET, 20/13 RUBBER	086188	3
2	SWITCH, GLCB01A2B LIMIT	086469	2
3	GLAND, SKINTOP PG 13.5 CABLE	086524	5
4	NUT, GMP-GL 21	086559	2
5	CONNECTOR, KLICK-GP21 RILL 21	086577	2
6	O-RING, SKINDICHT 0 21	086578	2
7	MOTOR ELECTR.18,5kW WITH BRAKE HPS18	087397	1
	MOTOR, 15kW1LA7164-2AA60-Z G26+C01	087396	1
8	GROMMET, 22MM I.D. RUBBER	087400	1
9	SWITCH, GSCB 01S1 LIMIT (UPPER BLADES COVER)	088407	1
10	SWITCH, AZ17-11ZRK SAFETY (SAWDUST HOPPER COVER)	094232	1
11	KEY, A217/170-B5 SAFETY SWITCH	094422	1
12	SENSOR, MSK-320 BLADES DISTANCE MEASUREMENT	096014	1
13	MOTOREDUCER, MR-80/64/1.1-1400/K3/V6	098663	1
14	ELECTRICAL BOX, EDGER	100776	1



15	SWITCH, GLCB01C SAFETY (ANTY-KICKBACK ASSEMBLY)	100910	1	
16	MOTOREDUCER, MR-50/78/0.18-900 K3/B8	101024	1	
17	PLATE, MOTOR MOUNT	101406-1	1	
	KIT, MAGNETIC STRIP	504117	1	
18	BRACKET, MAGNETIC STRIP	101025	1	
19	TAPE, MB320 MAGNETIC (0.5M)	096014-1	1	
20	CAM, SAFETY SWITCH	500073	1	
21	GUARD, BLADES SPACING CHAIN	500114-1	1	
22	BOX, EG300 CONTROL COMPLETE <a href="#">See Section 7.11</a>	504374	1	
23	BRACKET, SAFETY SWITCH	500140	1	
24	SWITCH, XALJ174F EMERGENCY STOP	E22703-P	1	
25	CLAMP, 1/2 WIRE PLASTIC	F05114-1	4	
26	BOLT, M10x30-5.8 HEX HEAD FULL THREAD ZINC	F81003-2	4	
27	BOLT, M10 X 70-8.8 HEX HEAD FULL THREAD ZINC	F81003-20	2	
28	NUT, M10-8-B HEX NYLON ZINC LOCK	F81033-1	6	
29	NUT, M10-8-B HEX ZINC	F81033-3	4	
30	WASHER, 10.5 FLAT ZINC	F81055-1	10	
31	TERMINAL, 2.5/5 RING	F81064-1	1	
32	ELEMENT, EE63 MOUNTING	F81080-4	10	
33	CONDUCTOR END, HI 1/6	F81083-3	12	
34	GLAND, DP 16/H CABLE	F81096-7	1	
35	BOLT, M5x16-5.8 HEX HEAD FULL THREAD ZINC	F81000-51	2	
36	WASHER, 5.3 FLAT ZINC	F81052-1	4	
37	NUT, M5-8 HEX ZINC	F81030-1	2	
38	AMMETER EQB72 40/80A - FOR E25 ELECTRIC MOTOR	505373	1	
	AMMETER EQB72 30/60A - FOR E20 ELECTRIC MOTOR	505372	1	
39	<b>PULLEY, 15/18.5 KW EA25 MOTOR</b>	085671	1	
	<b>PULLEY, SPB-3 D100 PBT100SPB3 TB 1610 (USA Version)</b>	502894	1	
40	<b>BUSHING, KEYED BORE SPLIT TAPER (E25 MOTOR)</b>	085714	1	
	<b>BUSHING, TAPER LOCK 1610/42 (USA Version)</b>	502895	1	
41	<b>V-BELT, BX39 1040 Lp</b>	101130	3	

## 7.9 Blade Setting Assembly

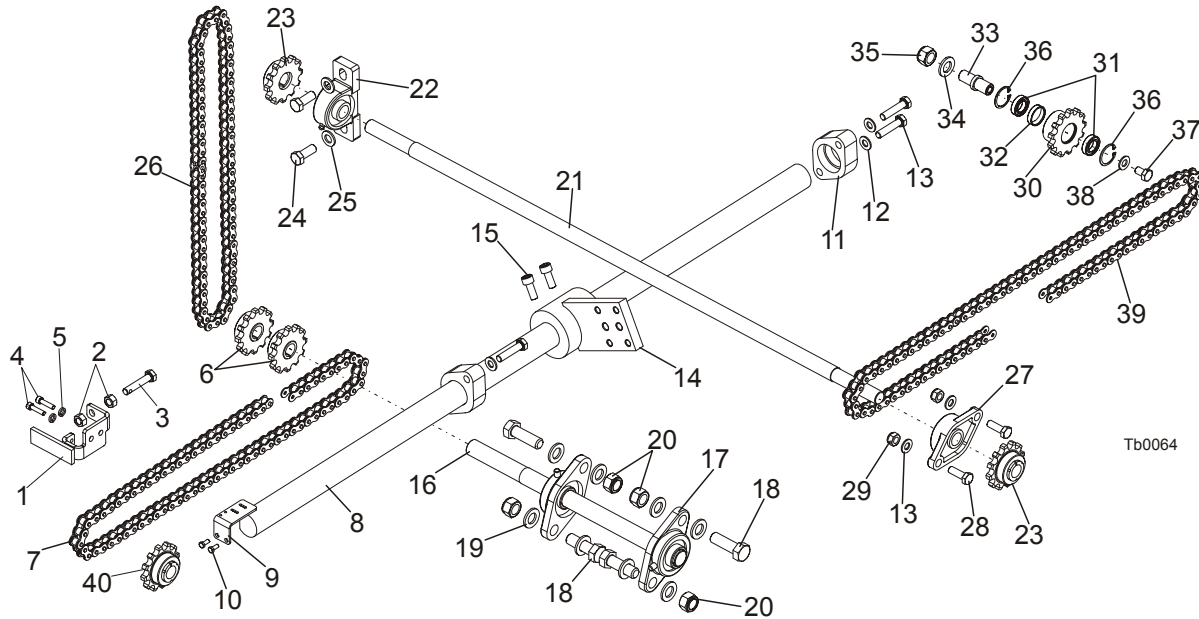

Tb0064

REF	DESCRIPTION (◆ Indicates Parts Available In Assemblies Only)	PART #	QTY.
	<b>TENSIONER, BLADES CHAIN</b>	101413	1
1	TENSIONER, EGDER CHAIN	500556-1	1
2	NUT, 10MM x 1.25 NYLON	F81033-6	2
3	BOLT, CHAIN TENSION	500071	1
4	SCREW, M6X25-8.8 HEX SOCKET HEAD CAP ZINC	F81001-41	2
5	WASHER, 8.2 SPLIT LOCK ZINC	F81054-4	2
6	SPROCKET W/TAPERLOCK	500546-1	2
7	CHAIN, 10B1-83 BLADE SLIDE	100713	1
8	ROD, BLADE SLIDE BLOCK	101417	1
9	BRACKET, SENSOR MOUNT	101399-1	1
10	BOLT, M5 X 12-5.8 HEX HEAD FULL THREAD ZINC	F81000-5	2
11	BEARING, COMPLETE	089134	2
12	BOLT, M10X45-8.8 HEX HEAD FULL THREAD ZINC	F81003-3	4
13	WASHER, 10.5 FLAT ZINC	F81055-1	6
14	BRACKET, BLADE SLIDE BLOCK	101009-1	1
15	SCREW, M10 X 25 8.8 HEX SOCKET HEAD CAP ZINC	F81003-32	2
16	ROD, BLADE & SENSOR SLIDE	101409-1	1
17	BEARING, UCFL 205 W/HOUSING	089124	2
18	BOLT, M16 X 50-8.8 HEX HEAD FULL THREAD ZINC	F81006-7	4
19	WASHER, 17 FLAT ZINC	F81058-1	8
20	NUT, M16-8 HEX NYLON ZINC LOCK	F81036-2	4
21	SHAFT, BLADE SCALE POINTER	500010-1	1
22	BEARING, UCP 204	500059	1
23	SPROCKET W/TAPERLOCK	500547-1	2
24	BOLT, M12X30-8.8 HEX HEAD FULL THREAD ZINC	F81004-22	2
25	WASHER, 13 FLAT ZINC	F81056-1	2

26	<b>CHAIN, 10B1-75 BLADE SCALE POINTER SHAFT</b>	100714	1	
27	<b>BEARING, UCFL 204</b>	500060	1	
28	<b>BOLT, M10x30-5.8 HEX HEAD FULL THREAD ZINC</b>	F81003-2	2	
29	<b>NUT, M10-8-B HEX NYLON ZINC LOCK</b>	F81033-1	2	
	<b>SPROCKET, LASER CHAIN TENSION</b>	500055	1	
30	SPROCKET, z=12 ZINC-PLATED	500548-1	1	
31	BEARING, 61903 SKF BALL	500051	2	
32	BUSHING, 30/25x8 ZINC-PLATED	500054	1	
33	PIN, SPROCKET	500063	1	
34	WASHER, 17 FLAT ZINC	F81058-1	1	
35	NUT, M16-8 HEX NYLON ZINC LOCK	F81036-2	1	
36	RING, W 31 INSIDE RETAINING	F81090-15	2	
37	BOLT, M10X16-8.8 HEX HEAD FULL THREAD ZINC	F81003-13	1	
38	WASHER, 10.5 FLAT ZINC	F81055-1	1	
39	<b>CHAIN, 10B1-93 BLADE SCALE POINTER</b>	100711	1	
40	<b>SPROCKET, 5/8"X3/8"(10B-1)</b>	<b>502382</b>	<b>1</b>	

## 7.10 Laser Guide Assembly (Optional)

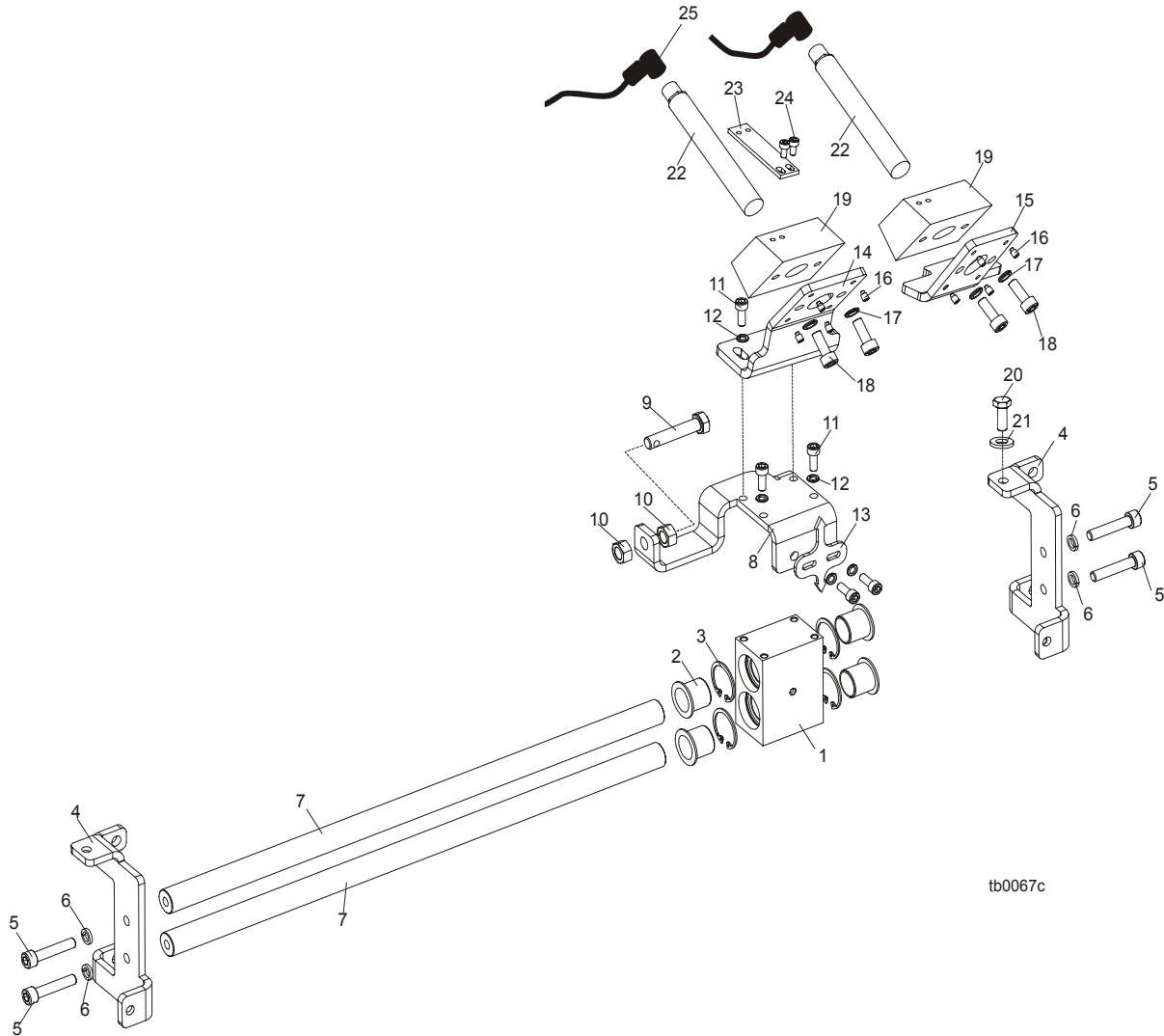

tb0067c

REF	DESCRIPTION (◆ Indicates Parts Available In Assemblies Only)	PART #	QTY.
	<b>GUIDE ASSEMBLY, EDGER LASER</b>	500056	1
	BLOCK, BLADE SLIDE COMPLETE	500067	1
1	LASER GUIDE, JAW, ZINC	094118-1	1
2	BUSHING, JFM-2023-21	094113	4
3	RING, W 30 INSIDE RETAINING	F81090-15	4
4	BRACKET, GUARDS COMPLETE	500070-1	2
5	SCREW, M8X40-8.8 HEX SOCKET HEAD CAP ZINC	F81002-29	4
6	WASHER 8.2 SPLIT LOCK ZINC	F81054-4	4
7	ROD, CLAMP JAW GUIDE	094116	2
	TENSIONER, LASER CHAIN	500058	1
8	BRACKET, BLADE SCALE POINTER	500072-1	1
9	BOLT, M10X50-8.8 HEX HEAD FULL THREAD ZINC	F81003-4	1
10	NUT, M10-8-B HEX ZINC	F81033-3	2
11	SCREW, M6x16 8.8 HEX SOCKET HEAD CAP ZINC	F81001-21	6
12	WASHER, Z6.1 SPLIT LOCK ZINC	F81053-3	6

13	POINTER, BLADE SCALE	500068-1	1	
	<b>LASER, CUTTING POINTER - GREEN</b>	500634	1	
	BRACKET, MOVING BLADE LASER - COMPLETE	500522	1	
	BRACKET, FIXED BLADE LASER - COMPLETE	500523	1	
14	BRACKET, LASER	500524-1	1	
15	BRACKET, LASER	500526-1	1	
16	SCREW, M6x8 45H	F81013-1	8	
17	WASHER, Z6.1 SPLIT LOCK ZINC	F81053-3	4	
18	SCREW, M6x16 8.8 HEX SOCKET HEAD CAP ZINC	F81001-21	4	
19	BLOCK, LASER MOUNT	500749	2	
20	BOLT, M6 x 16 8.8 HEX HEAD FULL THREAD ZINC	F81001-15	1	
21	WASHER, 6.4 FLAT ZINC	F81053-1	1	
22	LASER, Z5M18B-F-532-IG90 LINEAR (GREEN BEAM)	501025	2	
23	<b>LINK, EDGER LASER MOVING</b>	501091-1	1	
24	<b>BOLT, M4x8 8.8 SOCKET HEAD ZINC-PLATED</b>	F81011-36	2	
25	<b>CABLE, 5m SAFETY SWITCH</b>	087652	2	

**7.11 Control Box**

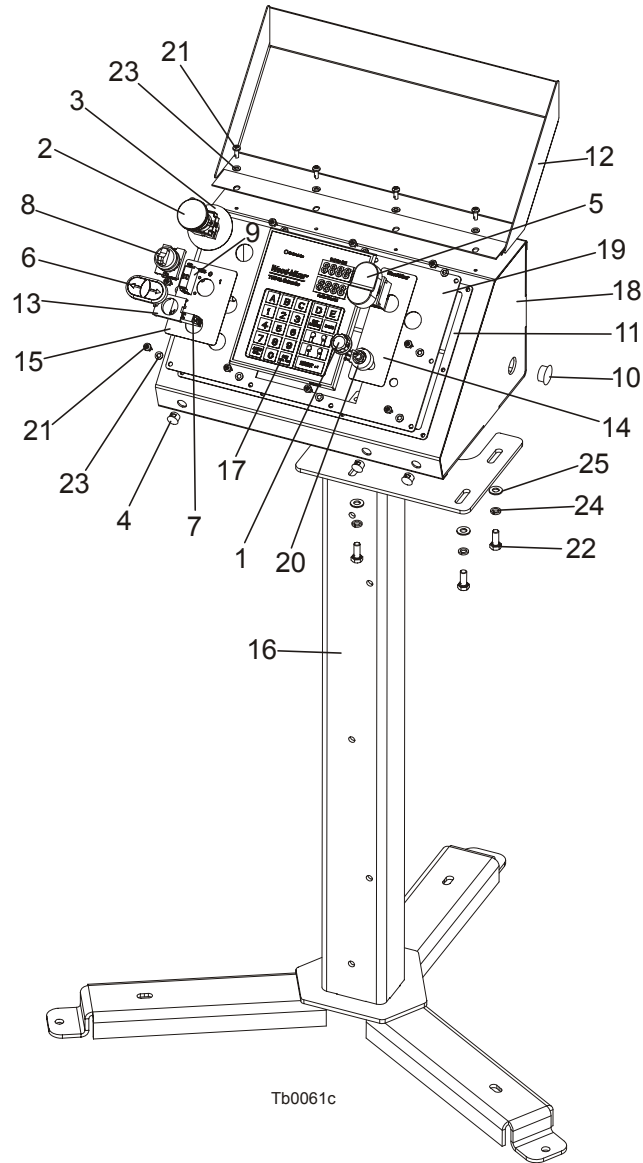

REF	DESCRIPTION (◆ Indicates Parts Available In Assemblies Only)	PART #	QTY.
	<b>CONTROL BOX, EG300 EDGER COMPLETE</b>	504374	1
1	KNOB, 1/4 ID FLUTED ROUND PLASTIC	033478	1
2	SWITCH, XB4 BS542 EMERGENCY STOP	086556	1
3	WASHER, ZBY9330 EMERGENCY STOP SWITCH	086561	1
4	CAP, DP 812 HEJMAN 12.7 DIA. HOLE	086773	3
5	SWITCH, 24V ILLUMINATED START/STOP	090452	1
6	BUTTON, M22-DD-S-X7/X7	090917	1
7	ELEMENT, M22-K10 CONTACT	091362	1
8	SWITCH, 2POSITION KEY	091467	1
9	ELEMENT, M22-K01 CONTACT	092684	1
10	CAP, 22.2 DIA. HOLE	093544	2
11	GASKET, CONTROL BOX	097132	1
12	COVER, LT20/40 CONTROL BOX - COMPLETE	097135-1	1

13	LINK, M22-A	100905	1	
14	DECAL, EDGER 1 CONTROL BOX	500035	1	
15	DECAL, EDGER 2 CONTROL BOX	500035-1	1	
16	STAND, LT20B CONTROL BOX	501651-1	1	
17	CONTROLLER, TBS01	503467	1	
18	CONTROL BOX, TVS	503536-1	1	
19	PANEL, EG300 CONTROL BOX	504375-1	1	
20	POTENTIOMETER, 1K	E20519	1	
21	BOLT, #10-24 x 1/2 PH PAN HD, TYPE 23	F05015-17	14	
22	BOLT, M8x20-8.8-B HEX HEAD FULL THREAD	F81002-4	4	
23	WASHER, 5.3 FLAT ZINC	F81052-1	14	
24	WASHER, 8.4 FLAT ZINC	F81054-1	4	
25	WASHER 8.2 FLAT ZINC	F81054-4	4	

**7.12 Table**

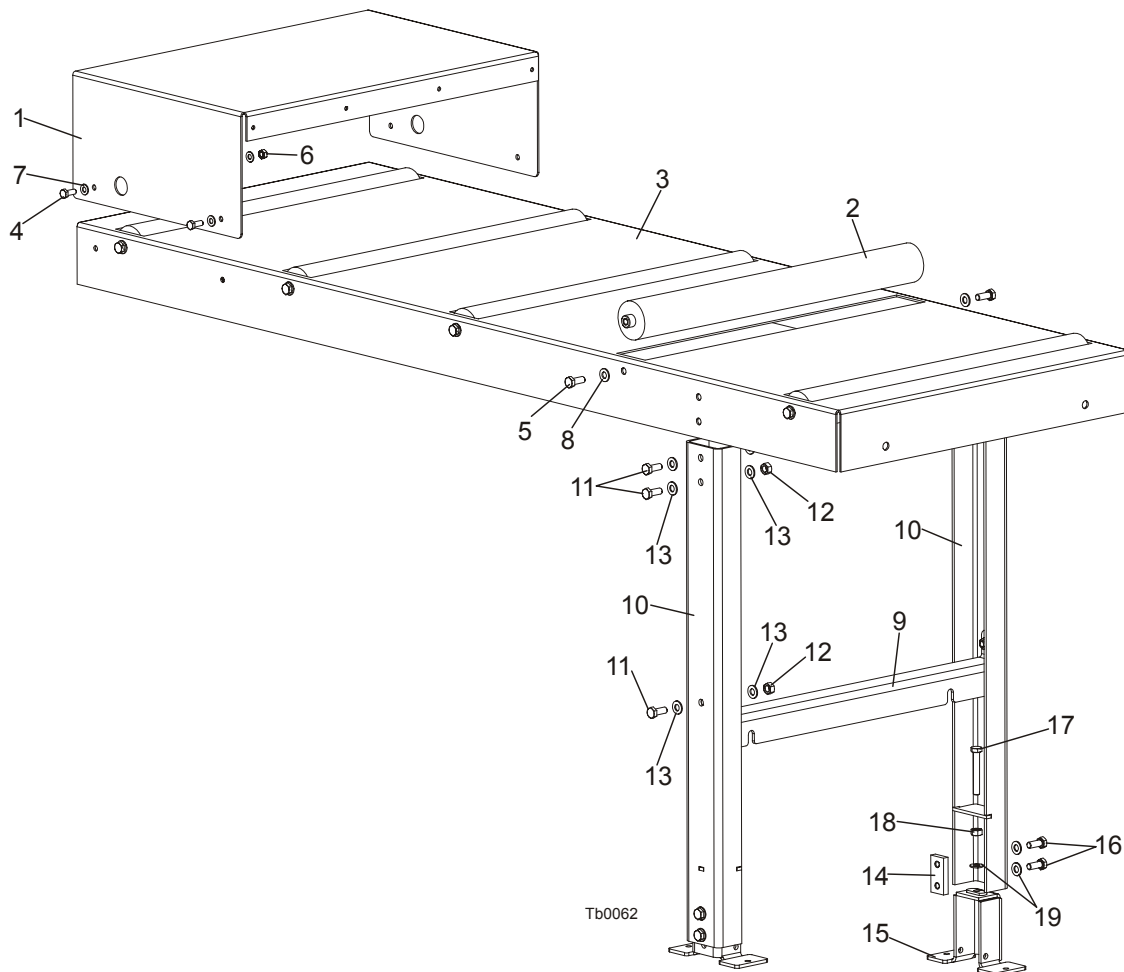

REF	DESCRIPTION (◆ Indicates Parts Available In Assemblies Only)	PART #	QTY.
	<b>TABLE, EDGER COMPLETE</b>	101400	1
1	GUARD, BOARDS	099299-1	1
2	ROLLER, 63.5/20x590	501090-1	5
3	TOP, TABLE	500078-1	1
4	BOLT, M8X20-5.8 HEX HEAD FULL THREAD ZINC	F81002-1	4
5	BOLT, M10X25-8.8 HEX HEAD FULL THREAD ZINC	F81003-11	10
6	NUT, M8-8-B HEX ZINC	F81032-1	4
7	WASHER, 8.4 FLAT ZINC	F81054-1	8
8	WASHER, 10.5 FLAT ZINC	F81055-1	10
	<b>LEG, EDGER TABLE COMPLETE</b>	500118	1
9	CROSS-BAR, TABLE LEGS	500074-1	1
10	LEG, EDGER TABLE	500076-1	2
11	BOLT, M10X25-8.8 HEX HEAD FULL THREAD ZINC	F81003-11	6
12	NUT, M10-8-B HEX ZINC	F81033-3	6
13	WASHER, 10.5 FLAT ZINC	F81055-1	12
	<b>COMPLETE ADJUSTABLE LEG FOOT</b>	101014	2
14	PLATE, M10 CLAMPING ZINC-PLATED	101242-1	1
15	FOOT, LEG ADJUSTABLE	101022-1	1



<b>16</b>	BOLT, M10X25-8.8 HEX HEAD FULL THREAD ZINC	F81003-11	2	
<b>17</b>	BOLT, M10 X 70-8.8 HEX HEAD FULL THREAD ZINC	F81003-20	1	
<b>18</b>	NUT, M10-8-B HEX ZINC	F81033-3	1	
<b>19</b>	WASHER, 10.5 FLAT ZINC	F81055-1	3	

**7.13 Sawdust Hopper**

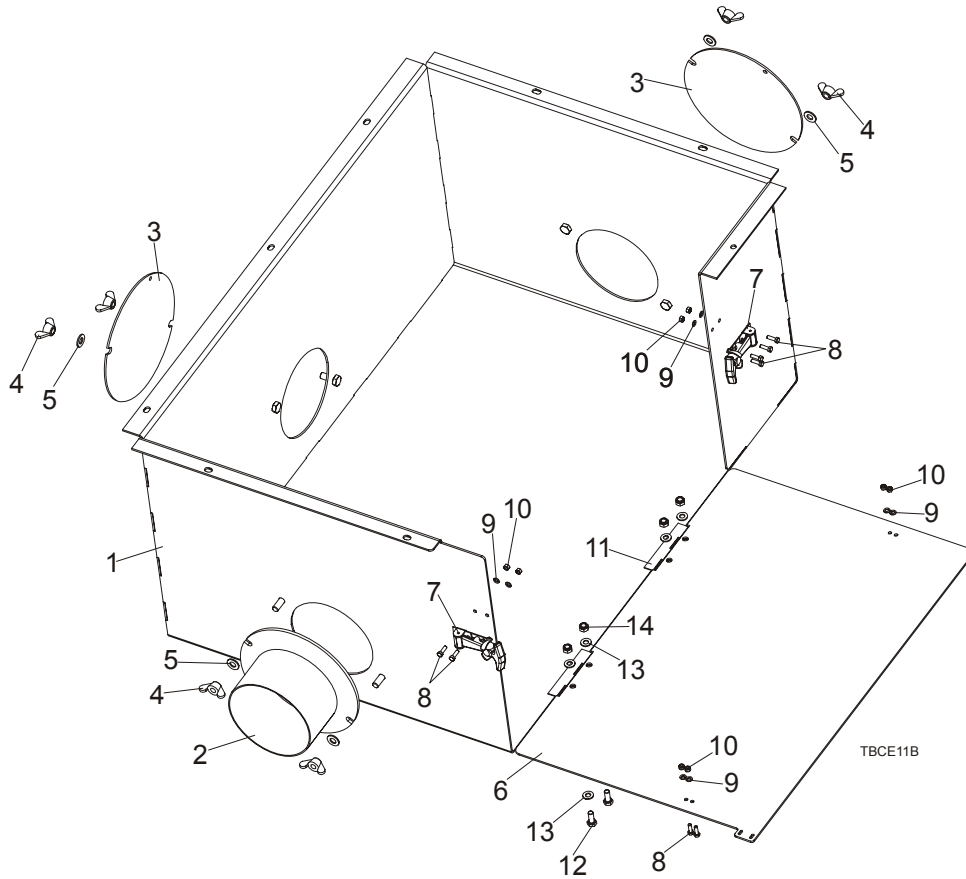

REF	DESCRIPTION (◆ Indicates Parts Available In Assemblies Only)	PART #	QTY.
	<b>HOPPER ASSEMBLY, EDGER SAWDUST DEEP</b>	101103	1
1	HOPPER WELDMENT, SAWDUST	101104-1	1
2	TUBE WELDMENT, SAWDUST EXHAUST SYSTEM CONNECTOR	095412-1	1
3	COVER, HOPPER HOLE PAINTED	095413-1	2
4	NUT, M10 WING ZINC	F81033-8	6
5	WASHER, 10.5 FLAT ZINC	F81055-1	6
6	COVER, HOPPER HINGED	100689-1	1
7	LATCH, FLEXIBLE DRAW	014829	2
8	BOLT, M5X16-5.8 HEX HEAD FULL THREAD ZINC	F81000-51	8
9	WASHER, 5.3 FLAT ZINC	F81052-1	8
10	NUT, M5-8 HEX ZINC	F81030-1	8
11	HINGE, COVER	089356	2
12	BOLT, M8X20-8.8 HEX HEAD FULL THREAD ZINC	F81002-4	4
13	WASHER, 8.4 FLAT ZINC	F81054-1	8
14	NUT, M8-8-B HEX, NYLON ZINC LOCK	F81032-2	4

## 7.14 Edger Decals

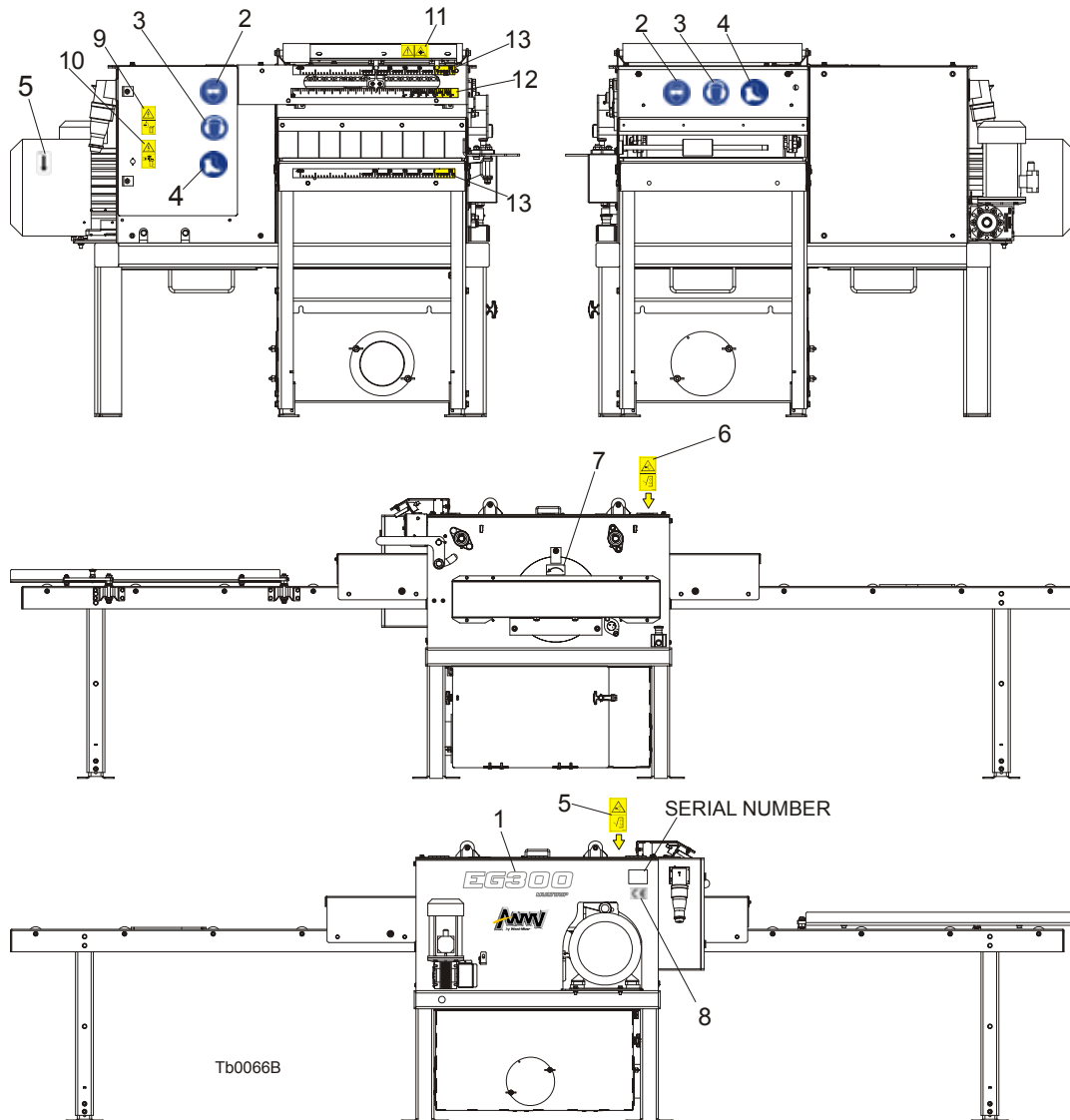

REF	DESCRIPTION (◆ Indicates Parts Available in Assemblies Only)	PART #	QTY.
	<b>DECAL KIT, EDGER W/ELECTRICAL BLADE SETTING</b>	<b>500995</b>	<b>1</b>
1	DECAL KIT, MACHINE NAME	099586	1
	PICTOGRAPHIC DECAL KIT, EDGER	099520	1
2	DECAL, EYE PROTECTION WARNING (PICTOGRAM)	S12004G	2
3	DECAL, EAR PROTECTION WARNING (PICTOGRAM)	S12005G	2
4	DECAL, USE SAFETY BOOTS (PICTOGRAM)	501465	2
5	DECAL, MOTOR ROTATION DIRECTION	S20097	1
6	DECAL, SAWMILL COVERS CAUTION	099220	2
7	DECAL, ROTATION DIRECTION	089296	1
8	DECAL, CE CERTIFIED SAWMILL	P85070	1
9	DECAL, HIGH VOLTAGE INSIDE THE ELECTRIC BOX (PICTOGRAM)	096316	1
10	DECAL, REMOVE THE PLUG BEFORE OPENING THE BOX (PICTOGRAM)	096319	1
11	DECAL, CAUTION - LASER BEAM (PICTOGRAM)	099504	1
12	SCALE, EDGER INCH	101006	1
13	SCALE, EDGER METRIC	101007	2

## SECTION 8 DC ELECTROMAGNETIC BRAKE

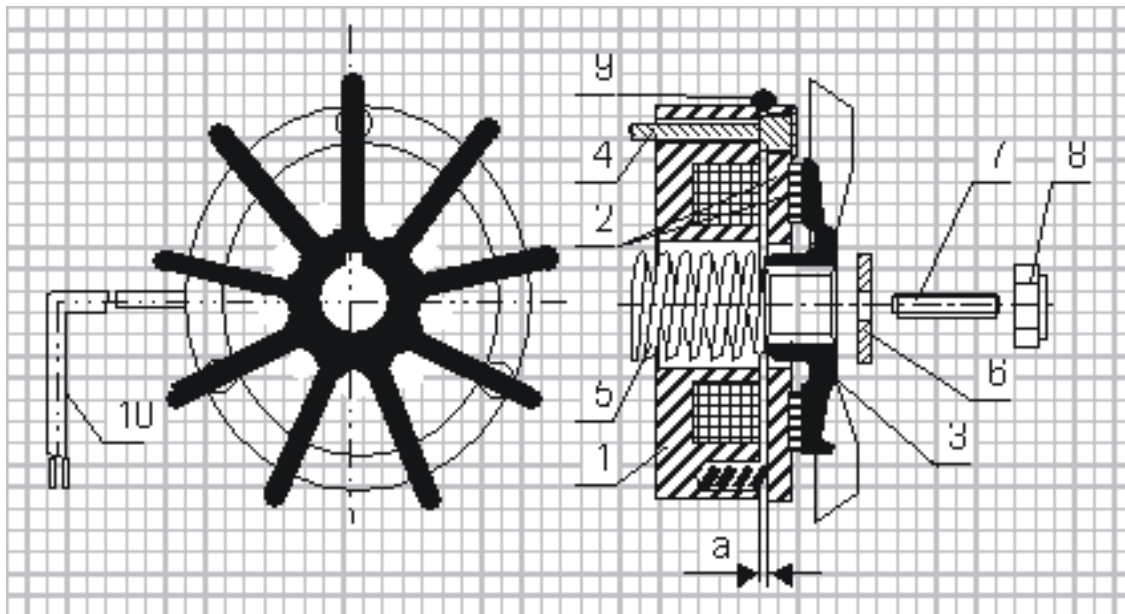

- 1 - Electromagnet,
- 2 - Armature complete with brake linings,
- 3 - Fan,
- 4 - Retaining bolt
- 5 - Central spring,
- 6 - Special washer,
- 7 - Set screw,
- 8 - Self-locking nut,
- 9 - Sealing ring,
- 10 - Output cable.

## 8.1 Design and principle of operation

The DC electromagnetic brake type H consists of 3 main subassemblies:

- electromagnet (1),
- armature complete (2)
- cast iron fan (3).

**Electromagnet (1) energised:** The DC voltage from the motor applied via the rectifying circuit causes the attraction of the armature (2) releasing the brake and thus the fan (3) is free to rotate.

**Electromagnet (1) de-energised:** The electromagnet stops to attract the armature (2) and spring presses the armature with brake linings (2) against the fan and the brake is thus applied.

## 8.2 Service

During normal operation and at the routine inspections verify the air gap and check if all screws are tight. In case when any symptoms of inefficient braking are observed, then use the self-locking nut (8) to re-adjust the air gap to the value corresponding to Table 1.

Such readjustment may be repeated until the brake linings are completely worn out. When this will occur, a complete armature with brake linings (2) must be replaced.

If the air gap of the brake is correctly adjusted and despite of it the brake does not operate properly (the brake fails to release), it may be caused by:

- the electromagnet (1): burned coil or defected output cable (10),
- rectifying circuit (installed in the electric motor terminal box).

The above mentioned subassemblies should be checked and defected part replaced.

**Table 1:**

TYPE	H-63	H-71	H-80	H-90	H-100	H-112	H-132	H-160
Nominal Gap „a”	0.2 ±0,05	<b>0.2</b> ±0,05	<b>0.2</b> ±0,05	<b>0.2</b> ±0,05	<b>0.2</b> ±0,1	<b>0.2</b> ±0,1	<b>0.2</b> ±0,1	<b>0.2</b> ±0,1

**EC declaration of conformity**  
**according to EC Machinery Directive 2006/42/EC**

We herewith declare,

Wood-Mizer Industries sp. Z O.O.  
114 Nagorna street, 62-600 Kolo; Poland.

That the following described machine in our delivered version complies with the appropriate basic safety and health requirements of the EC Machinery Directive 2006/42/EC based on its design and type, as brought into circulation by us. In case of alteration of the machine, not agreed by us, this declaration is no longer valid.

Designation of the machine:	<b>Edger Multirip</b>
TYPE:	EE25S-EMR
No. of manufacturer:	.....
Applicable EC Directives:	EC Machinery Directive 2006/42/EC EC Low-Voltage Directive 2006/95/EC EC Electromagnetic Compatibility Directive 2004/108/EC
Applicable Harmonized Standards:	EN ISO 12100 : 2009; EN ISO 13857 : 2008; EN 847-1 : 2007; EN 1870-4 : 2009 ; EN 60204-1 : 2007.
Notified Body according to annex IV :	PZ.LSV; Pruf- und Zertifizierungsstelle des Spitzenverbandes der landwirtschaftlichen Sozialversicherung
Notification No:	2157
Responsible for:	EC type examination
EC type-examination certificate no.	LSV-EG-2009/103
Responsible for Technical Documentation:	Roman Frontczak / R&D Director
Date/Authorized Signature:	29. 12. 2009 
Title:	R&D Director