

Twin Blade Edger

Safety, Operation, Maintenance & Parts Manual

EE15

rev. A2.00



Safety is our #1 concern! Read and understand all safety information and instructions before operating, setting up or maintaining this machine.

Form #904

Table of Contents

Section-Page

SECTION 1	SAFETY	1-1
1.1	Safety Symbols.....	1-1
1.2	Safety Instructions.....	1-2
1.3	Twin Blade Edger Specifications.....	1-8
SECTION 2	SERVICING THE EDGER	2-1
2.1	If You Need To Order Parts.....	2-1
2.2	Customer and Edger Identification.....	2-2
2.3	If You Need Service.....	2-4
SECTION 3	EDGER SETUP	3-1
3.1	Pre-Operation Check.....	3-1
3.2	Edging Lumber.....	3-4
SECTION 4	MAINTENANCE	4-1
4.1	Changing the Blades.....	4-1
4.2	Tensioning the Belts.....	4-4
4.3	Tensioning the Chains.....	4-6
4.4	Checking the Rollers.....	4-7
4.5	Lubrication.....	4-8
4.6	Maintaining and Sharpening Anti-Kickback Fingers.....	4-9
4.7	Alignment.....	4-10
SECTION 5	TROUBLESHOOTING	5-1
5.1	Boards Are Not Self-Feeding.....	5-1
5.2	Jammed Boards.....	5-2
SECTION 6	PARTS	6-1
6.1	How To Use The Parts List.....	6-1
6.2	Sample Assembly.....	6-1
6.3	Anti-Kickback & Press Roller.....	6-2
6.4	Blade Shaft Assembly.....	6-4
6.5	Covers.....	6-6
6.6	Feed Table & Return Rollers.....	6-8
6.7	Feed Roller Assemblies & Roller Chain.....	6-9
6.8	Front Guide Fence.....	6-10
6.9	Gear Box & Idler.....	6-11
6.10	Motor, Hour Meter & E-Stop (EE15 Only).....	6-12
6.11	Outfeed Table.....	6-14
6.12	Setworks Dial & Indicator.....	6-15
6.13	Setworks Gear & Shaft.....	6-16
6.14	Shaft End Covers.....	6-17
6.15	Starter Assembly (EE15 Only).....	6-18
6.16	Stationary Legs.....	6-19

Table of Contents

Section-Page

SECTION 7 ELECTRICAL INFORMATION

7-1

7.1 Wiring Diagrams7-1
7.2 Electrical Component Lists7-3
7.3 Component Layout Diagram7-4

SECTION 1 SAFETY

1.1 Safety Symbols

The following symbols and signal words call your attention to instructions concerning your personal safety. Be sure to observe and follow these instructions.



DANGER! indicates an imminently hazardous situation which, if not avoided, will result in death or serious injury.



WARNING! suggests a potentially hazardous situation which, if not avoided, could result in death or serious injury.



CAUTION! refers to potentially hazardous situations which, if not avoided, may result in minor or moderate injury or damage to equipment.



IMPORTANT! indicates vital information.

NOTE: gives helpful information.



Warning stripes are placed on areas where a single decal would be insufficient. To avoid serious injury, keep out of the path of any equipment marked with warning stripes.

1.2 Safety Instructions

NOTE: ONLY safety instructions regarding personal injury are listed in this section. Caution statements regarding only equipment damage appear where applicable throughout the manual.

OBSERVE SAFETY INSTRUCTIONS



IMPORTANT! Read the entire Owner's Manual before operating the Edger. Take notice of all safety warnings throughout this manual and those posted on the machine. Keep this manual with this machine at all times, regardless of ownership.

Also read any additional manufacturer's manuals and observe any applicable safety instructions including dangers, warnings, and cautions.

Only persons who have read and understood the entire operator's manual should operate the Edger. The Edger is not intended for use by or around children.

IMPORTANT! It is always the owner's responsibility to comply with all applicable federal, state and local laws, rules and regulations regarding the ownership, operation and towing of your Wood-Mizer Edger. All Wood-Mizer owners are encouraged to become thoroughly familiar with these applicable laws and comply with them fully while using or towing the Edger.



WEAR SAFETY CLOTHING



WARNING! Secure all loose clothing and jewelry before operating the Edger. Failure to do so may result in serious injury or death.

WARNING! Always wear eye, ear, respiration, and foot protection when operating or servicing the Edger.



KEEP EDGER AND AREA AROUND EDGER CLEAN



DANGER! Maintain a clean and clear path for all necessary movement around the Edger and lumber stacking areas. Failure to do so will result in serious injury.

DISPOSE OF SAWING BY-PRODUCTS PROPERLY



IMPORTANT! Always properly dispose of all sawing by-products, including sawdust and other debris, coolant, oil, fuel, oil filters and fuel filters.

CHECK EDGER BEFORE OPERATION OR TOWING



DANGER! Make sure all guards and covers are in place and secured before operating or towing the Edger. Failure to do so may result in serious injury.



WARNING! Always shut off the engine to stop the blade whenever the Edger is not in use. Failure to do so may result in serious injury.

WARNING! Do not for any reason adjust the engine drive belts with the engine running. Doing so may result in serious injury.

WARNING! Always ensure that there is a sharp point on the anti-kickback fingers before each use of the Edger.

Be sure anti-kickback fingers are free from obstruction and are in a downward position with lever released. Failure to do so may result in serious injury.

KEEP PERSONS AWAY



DANGER! Keep all persons out of the path of moving equipment and boards when operating the Edger. Failure to do so will result in serious injury.

KEEP HANDS AWAY



DANGER! Engine components can become very hot during operation. Avoid contact with any part of a hot engine. Contact with hot engine components can cause serious burns. Therefore, never touch or perform service functions on a hot engine. Allow the engine to cool sufficiently before beginning any service function.

DANGER! Moving Parts Can Crush and Cut. Keep hands clear. Make sure all guards and covers are in place and secured before operating or towing. Failure to do so may result in serious injury.

DANGER! Always be aware of and take proper protective measures against rotating shafts, pulleys, fans, etc. Always stay a safe distance from rotating members and make sure that loose clothing or long hair does not engage rotating members resulting in possible injury.

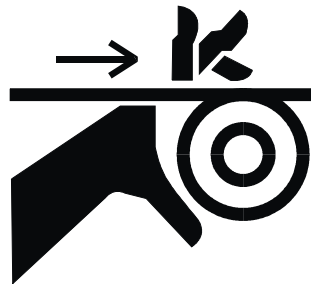



WARNING! Coastdown Required. Always shut off the engine and allow all moving parts to come to a complete stop before removing any guards or covers. Do NOT operate with any guards or covers removed.

WARNING! Kickback Hazard. Stay clear of area during operation. Follow all anti-kickback service and safety rules. Failure to do so may result in serious injury.



CAUTIONS FOR ENGINE OPERATION



DANGER! Operate your engine/machine only in well ventilated areas. The exhaust gases of your engine can cause nausea, delirium and potentially death unless adequate ventilation is present.

DANGER! Never operate an engine with a fuel or oil leak. The leaking fuel or oil could potentially come in contact with hot surfaces and ignite into flames.

WARNING! Do not operate engine without proper and operational spark arrester/muffler. Sparks emitted from the engine exhaust could ignite surrounding materials, causing serious injury or death.

USE PROPER PROCEDURE WHEN CONDUCTING ELECTRICAL SAFETY CHECKS AND MAINTENANCE



DANGER! Make sure all electrical installation, service and/or maintenance work is performed by a qualified electrician and is in accordance with applicable electrical codes.

DANGER! Hazardous voltage inside the electric disconnect box, starter box, and at the motor can cause shock, burns, or death. Disconnect and lock out power supply before servicing! Keep all electrical component covers closed and securely fastened during Edger operation.



WARNING! Consider all electrical circuits energized and dangerous.

WARNING! Never assume or take the word of another person that the power is off; check it out and lock it out.

WARNING! Do not wear rings, watches, or other jewelry while working around an open electrical circuit.

1.3 Twin Blade Edger Specifications

See Table 1-1. The power option specifications of the Wood-Mizer Twin Blade Edger is listed below.

	Motor Specifications
Motor Type	E15 Electric Motor
Manufacturer	Tamel S.A., Poland
Voltage at 380V	380-420V
Maximum Current	22.3 A
Maximum Torque	2920 RPM
Rated Output	11 kW (15KM)
Manufacturer Part #	SG132S2PCHM
WM Part #	088049

TABLE 1-1

See Table 1-2. The overall dimensions of the Twin Blade Edger is shown below.

Model	Maximum Length	Maximum Width	Height	Outfeed Table	Infeed Table	Weight
E15	20' 5" (6.15 m)	70" (1.75 m)	51" (1.3 m)	10' (3.0 m)	6' 5" (1.9 m)	1880 lbs. (850 kg)

TABLE 1-2

See Table 1-3. The noise level.

	Engaged
Twin Blade Edger Equipped With E15 Electric Motor	84 dB (A)

TABLE 1-3

See Table 1-4. Other saw specifications of the Twin Blade Edger are listed below.

	Width of Passage	Maximum Board Thickness	Feed Speed	Blade Size (Wood-Mizer Products)	Saw Diameter
Saw Specifications	20.75" (70 cm)	2" (5 cm)	50'/min (15m/min)	16" x 14" x 18 tooth	14"

TABLE 1-4

SECTION 2 SERVICING THE EDGER

Wood-Mizer is committed to providing you with the latest technology, best quality and strongest customer service available on the market today. We continually evaluate our customers' needs to ensure we're meeting current wood-processing demands. Your comments and suggestions are welcome.

2.1 If You Need To Order Parts

From Europe call our European Headquarters and Manufacturing Facility in Kolo, Poland at **+48-63-2610233**. From the continental U.S., call our toll-free Parts hotline at **1-800-448-7881**. Please have the vehicle identification number and your customer number ready when you call. Wood-Mizer will accept these methods of payment:

- Visa, Mastercard, or Discover
- COD
- Prepayment
- Net 15 (with approved credit)

Be aware that shipping and handling charges may apply. Handling charges are based on size and quantity of order. In most cases, items will ship on the day they are ordered. Second Day and Next Day shipping are available at additional cost.

If your edger was purchased outside of the United States, contact your distributor for replacement parts.

2.2 Customer and Edger Identification

Each Wood-Mizer edger has a 17-digit Vehicle Identification Number (VIN). In addition, when you pick up your edger, you will receive a customer number. These three numbers will help expedite our service to you. Please locate them now and write them below so you have quick, easy access to them. VIN plates can be found in two locations: 1) on the Edger's frame; 2) inside the gearbox housing.

See Figure 2-1. See the following figures for V.I.N. locations.

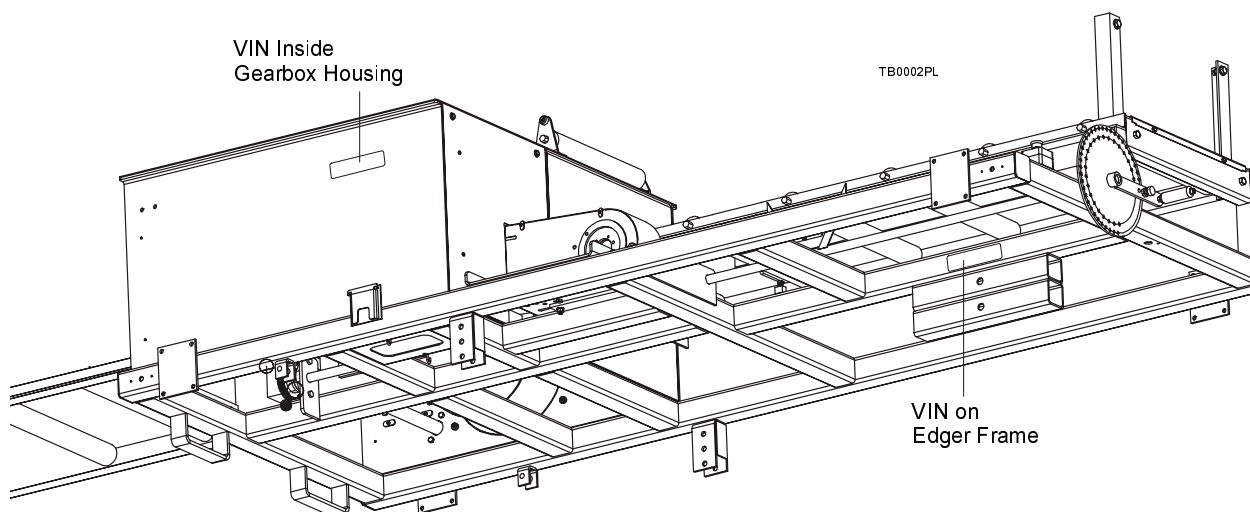

FIG. 2-1

(To be filled in by purchaser)
Edger VIN _____
Customer No. _____

See below for a description of the V.I.N.

Company Identification Number 456=Wood-Mizer Indiana	Weight Class; A=Under 3,000 lbs B=3,001-4,000 lbs C=4,001-5000 lbs	Product No.; 1 = Edger	Length of the Trailer; 14=14 Ft.	Number of axles on the trailer	Check Digit Add all the numbers and divide by 11	Year of Manufacture; X=1999, Y=2000, Z=2001	State of Manufacture N=Indiana, P=Poland	Month of Manufacture A=January, B=February, C=March, etc...	Revision Level	Sequence Number Ranging from 000-999	End of 17-Digit VIN	Revision Level (Repeated)	Two-Digit Minor Revision Level
456	A	1	14	1	X	S	N	A	A1	017		A1	.01

V.I.N. DESCRIPTION.

2.3 If You Need Service

From Europe call our European Headquarters and Manufacturing Facility in Kolo, Poland at **+48-63-2610233**. From the continental U.S., call us toll-free at **1-800-525-8100**. Ask to speak with a Customer Service Representative. Please have your vehicle identification number and your customer number ready when you call. The Service Representative can help you with questions about the operation and maintenance of your edger. He also can schedule you for a service call.

Office Hours: All times are Eastern Standard Time. Please remember that Indiana does not go on Daylight Savings Time in the summer.

Country	Monday - Friday	Saturday	Sunday
U.S., Indiana	8 a.m. to 5 p.m.	8 a.m. to 4 p.m.	Closed
Poland	8 a.m. to 4:30 p.m.	8 a.m. to 1 p.m.	Closed

If your edger was purchased outside the United States, contact the distributor for service.

SECTION 3 EDGER SETUP

3.1 Pre-Operation Check

Prior to operating the Edger; always perform these basic checks:

1. Make sure the Edger is level. Secure the legs to the surface.



CAUTION! Always be sure the machine is level prior to operating. Failure to do so can and will affect machine operation and wear life.

2. Make sure the outfeed table is level with the rest of the Edger. Place blocks under the table if necessary.
3. Make sure the engine drive belt is tensioned properly. [See Section 4.2](#) for more information.



WARNING! Do not for any reason adjust the engine drive belts with the engine running. Doing so may result in serious injury.

4. Be sure the anti-kickback fingers are in proper working condition.

See Figure 3-1.



WARNING! Always ensure that there is a sharp point on the anti-kickback fingers before each use of the Edger.

Be sure anti-kickback fingers are free from obstruction and are in a downward position with lever released. Failure to

3 Edger Setup

Pre-Operation Check

do so may result in serious injury.

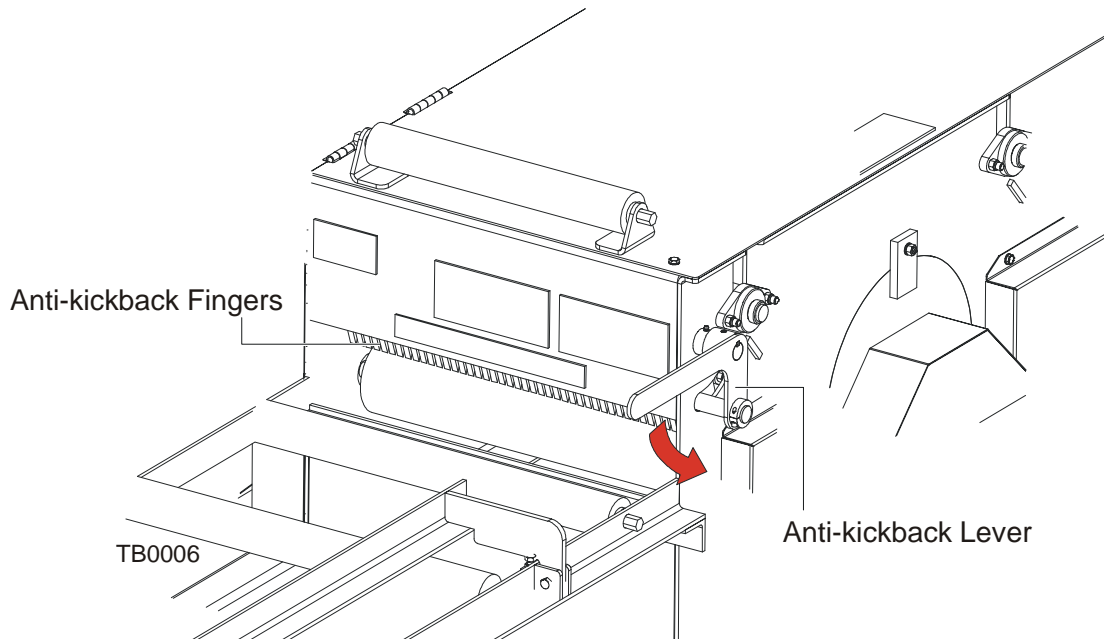



FIG. 3-1

5. Be sure all guards and covers are in place and secured.

 **DANGER!** Make sure all guards and covers are in place and secured before operating or towing the Edger. Failure to do so may result in serious injury.

6. Also be aware that the blades are spinning whenever the engine is ON. You should always turn off the engine to stop the blade whenever the Edger is not in use and ensure that all parts have stopped moving before removing any covers or guards.

 **WARNING!** Coastdown Required. Always shut off the engine and allow all moving parts to come to a complete stop before removing any guards or covers. Do NOT operate with any guards or covers removed.

WARNING! Always shut off the engine to stop the blade whenever the Edger is not in use. Failure to do so may result in serious injury.

See Figure 3-2. An Emergency Stop is located at the front of the Edger, to the left of the Networks dial. Press the Emergency Stop to shut down the engine. Before operating the Edger again, reset the switch by turning the button to the right and releasing.

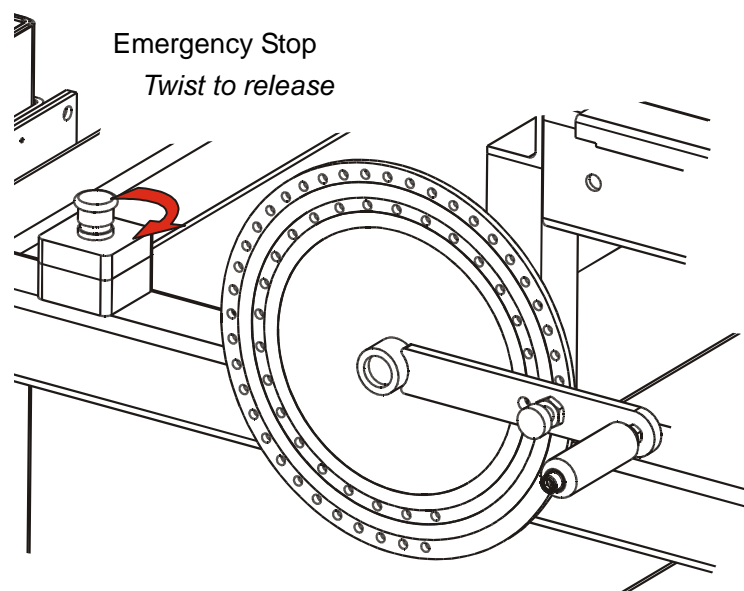

FIG. 3-2

3.2 Edging Lumber



DANGER! Make sure all guards and covers are in place and secured before operating or towing the Edger. Failure to do so may result in serious injury.

DANGER! Keep all persons out of the path of moving equipment and boards when operating the Edger or loading boards. Failure to do so will result in serious injury.

DANGER! Moving Parts Can Crush and Cut. Keep hands clear. Make sure all guards and covers are in place and secured before operating or towing. Failure to do so may result in serious injury.

DANGER! Maintain a clean and clear path for all necessary movement around the Edger and lumber stacking areas. Failure to do so will result in serious injury.



WARNING! Always shut off the engine to stop the blade whenever the Edger is not in use. Failure to do so may result in serious injury.

WARNING! Always wear eye, ear, respiration, and foot protection when operating the Edger. Failure to do so may result in serious injury.

WARNING! Secure all loose clothing and jewelry before operating the Edger. Failure to do so may result in serious injury or death.

After performing the pre-operation check, you are ready to begin edging lumber.

1. Set the setworks dial indicator for the desired size of boards to be cut.

See Figure 3-3. The setworks dial adjusts the movable saw blade closer to or farther away from the fixed saw blade, thus setting the width of the cut to be made. To set, pull the dial indicator locking pin out, turn the setworks handle as necessary, and release the pin into the appropriate labeled hole, from 3" to 15" (or 8 to 38 cm).

For example, setting the dial at 3" will position the movable blade 3" from the fixed blade. Resulting cuts will be 3" in width.

NOTE: To change from using U.S. measurements to metric measurements, simply remove the locking pin from the handle's outer hole and reinstall to the handle's inner hole.

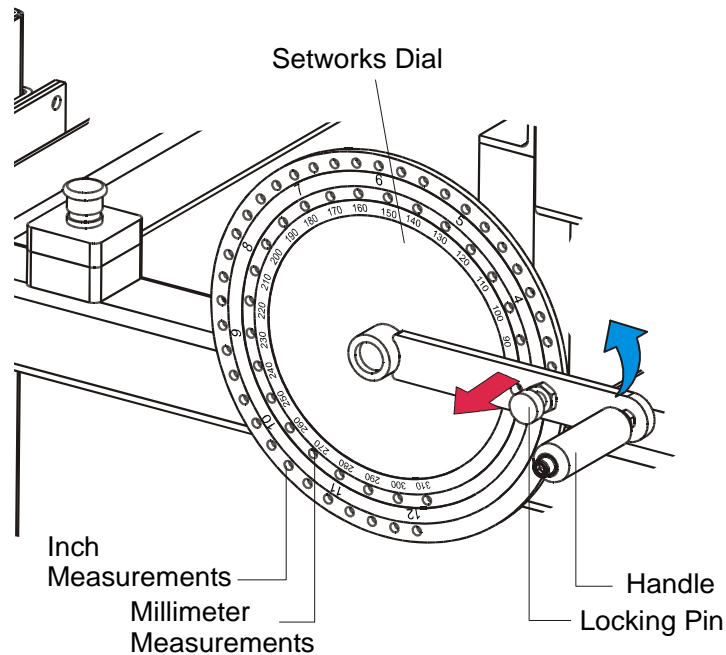

FIG. 3-3

3 Edger Setup

Edging Lumber

2. Set the front fence.

See Figure 3-4. The front fence of the infeed table can be left in place and used as a guide or pivoted up, out of the way.

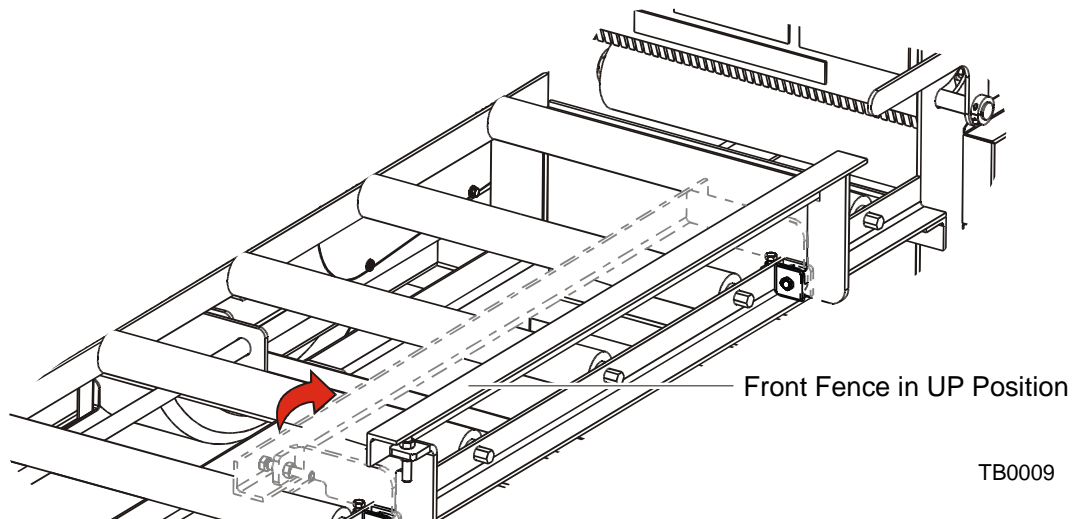



FIG. 3-4

3. Position a board on top of the infeed rollers.
4. Start the motor. If you have an electric Edger, see the appropriate manual supplied with your specific motor configuration for detailed operating instructions.

 **IMPORTANT!** If at any time you need to immediately stop the engine and/or Edger operation, press the Emergency Stop button located at the front of the Edger.

See Figure 3-5.

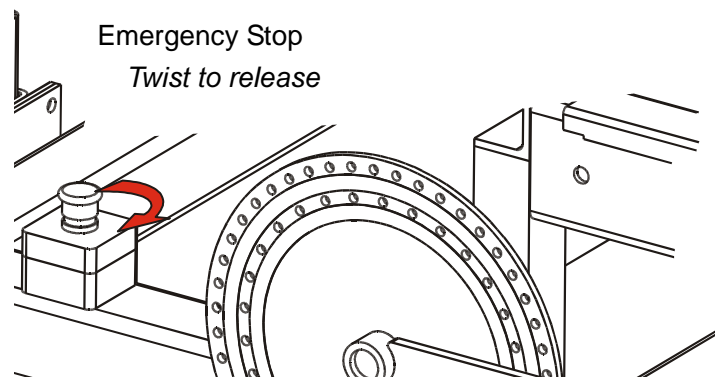

FIG. 3-5

5. Gently push the board through the anti-kickback fingers into the blade until the board begins to feed itself.
6. If the board needs to be edged again, lift the board from the outfeed table. Use the return feed rollers on top of the Edger unit to return the board to the infeed operator.

SECTION 4 MAINTENANCE

Refer to the engine manufacturer's manual for maintenance intervals and procedures regarding the power supply unless otherwise instructed in this manual. Follow the manufacturer's recommendations for dusty conditions.



IMPORTANT! This manual only provides information about additional procedures or procedures to be performed at different time intervals than found in the manufacturer's manuals. Refer to the manufacturer's manual for complete maintenance instructions.

4.1 Changing the Blades

1. Replace the blades as necessary. Dull blades will cause the engine to work harder and will result in decreased cut quality and accuracy. Blade life will vary depending on maintenance of machine, operator, species of wood being sawn, and condition of wood being sawn.



DANGER! Before changing the saws, make sure the arbor has come to a complete stop and the motor is shut off completely. Failing to do so can cause serious injury.



WARNING! Always wear eye, glove and foot protection when handling saw blades.

2. To access the blades, unbolt and open the blade housing cover.
3. With the shaft secured, use the provided spanner wrenches to loosen the locking nuts on the blades.

4

Maintenance

Changing the Blades

4. Remove the cone/bearing assembly from the Edger. To remove, first unbolt and remove the blade shaft bearing guard. Loosen the cone retaining bolt. Remove the three mounting nuts on the bearing plate and pry the plate from the Edger.

See Figure 4-1.

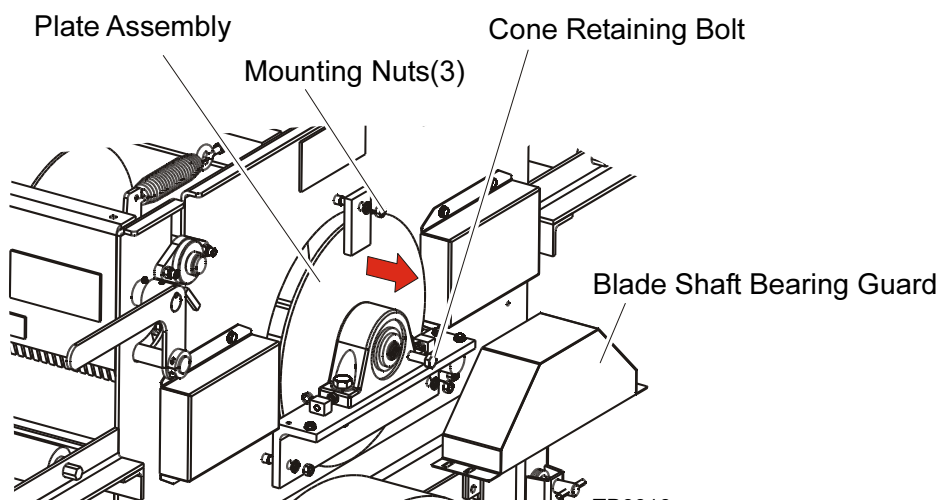

FIG. 4-1

5. Next, remove the blades from the shaft. Remove the fixed blade locking nut and the fixed blade. Loosen the two allen screws on the fixed blade arbor and remove the arbor from the shaft.

6. Unscrew and remove the adjustable blade locking nut. Slide the movable blade from the shaft.

See Figure 4-2.

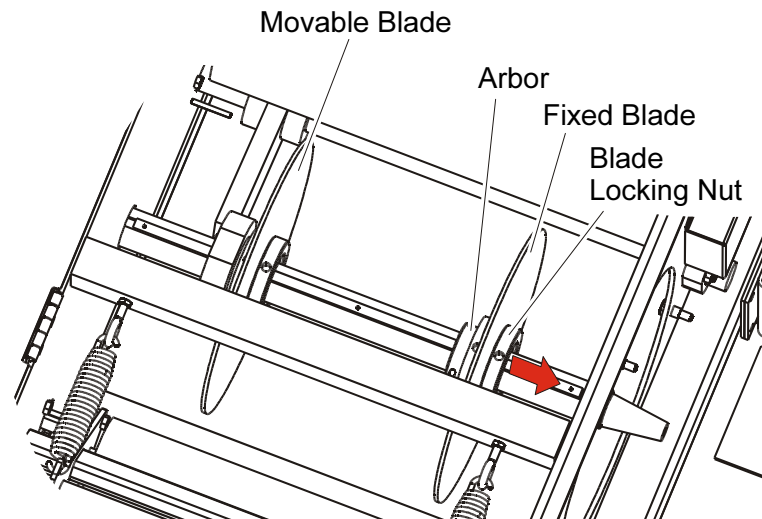

FIG. 4-2

7. Apply an anti-seize lubricant to the face of the arbor and to the face and threads of the blade locking nut.
8. Install a new or resharpened blade to shaft and position it next to the movable blade arbor. Loosely reinstall the adjustable blade locking nut.
9. Reinstall the fixed blade arbor to the shaft. Install a new or resharpened blade, and loosely reinstall the fixed blade locking nut.
10. Reinstall the cone/bearing assembly and secure in place with the existing mounting nuts.
11. Reinstall the cone retaining bolt and the blade shaft bearing guard.
12. With the shaft secured, use the spanner wrenches to tighten the blade locking nuts all the way.
13. Align the blades. [See Section 4.8.](#)
14. During alignment, the blade arbor allen screws will be tightened to secure the blade assemblies in place.
15. After alignment, be sure to close and re-secure the blade housing cover.

4.2 Tensioning the Belts



DANGER! Always shut off the engine and allow all moving parts to come to a complete stop before removing any guards or covers. Failure to do so will result in serious injury.



WARNING! Do not for any reason adjust the engine drive belts with the engine running. Doing so may result in serious injury.



CAUTION! Never apply belt dressing as this will damage the belt and cause early failure.

1. Check the drive belt for wear every 8 hours of operation and more frequently during the first 24-48 hours of operation. Tension or replace as necessary. Tension should be 9/16" deflection with 9 lbs of force for new belts or 9/16" deflection with 6 lbs of force for used belts.

See Figure 4-3. To tension the drive belt:

- Unbolt and open the gearbox housing cover.
- Locate the mounting bolts which secure the drive belt guard to the gearbox housing. Loosen these so that the drive belt housing is free to slide as necessary.
- Loosen the four engine mounting bolts.
- Use the two adjustment bolts as shown to move the engine mount towards the front of the Edger until the belt is properly tensioned. Be sure to adjust the bolts evenly so the motor remains in alignment.



CAUTION! Do not over tighten the drive belt as it can cause premature belt and/or bearing failure.

CAUTION! Do not under-tighten the drive belt as it can cause one or all of the following damages: slippage of the belt on the drive pulley, binding or fetching up of the saws while in the cut, damage or bending of saws

- Retighten the engine mounting bolts. Retighten the belt guard mounting bolts.

2. Check the idler belt for wear every 8 hours of operation. Tension or replace as necessary. Tension should be 1/8" deflection with 9 lbs of force for new belts or 1/8" deflection with 6 lbs of force for used belts.

See Figure 4-4. To tension the idler belt:

- With the gearbox housing cover still open, locate the idler drive bracket. Loosen the bottom mounting bolt first, then the top adjustment bolt.
- Push the bottom of the bracket towards the idler pulley until the belt is tensioned as needed.
- Retighten the top adjustment bolt and the bottom idler bracket mounting bolt.

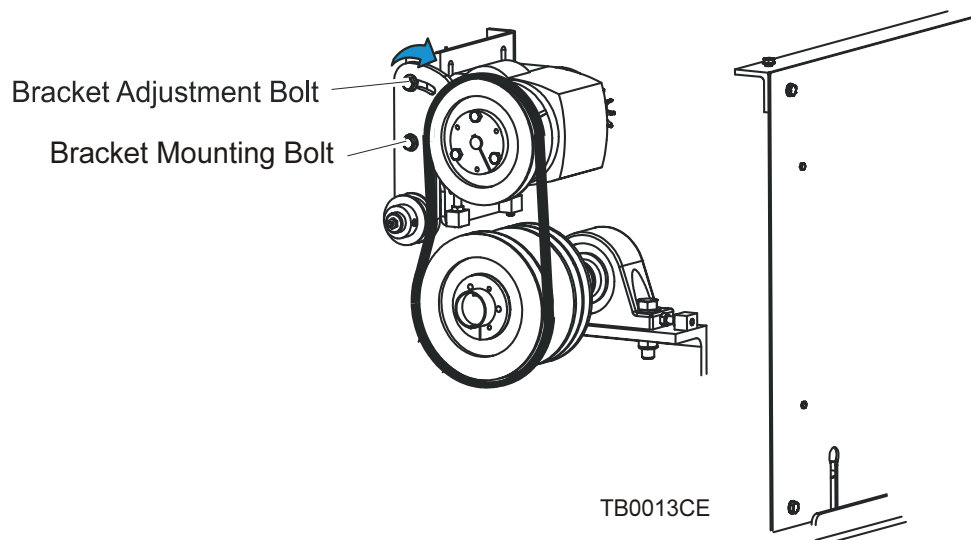

FIG. 4-4

3. Close the gearbox housing cover and use the existing bolts to secure.

4.3 Tensioning the Chains



Check the drive chains for tension every 40 hours of operation and tension as necessary. The chains should have approximately 1/2" of slack. **NOTE:** The smaller idler chains have no adjustment.

See Figure 4-5. To tension the drive chains, unbolt and open the gearbox housing cover.

- Loosen the four gearbox mounting bolts.
- Use the adjustment bolts underneath the gearbox to raise the gearbox until the chains are tensioned as needed. Be sure to adjust the bolts evenly.
- Retighten the gearbox mounting bolts and close and secure the gearbox housing cover.

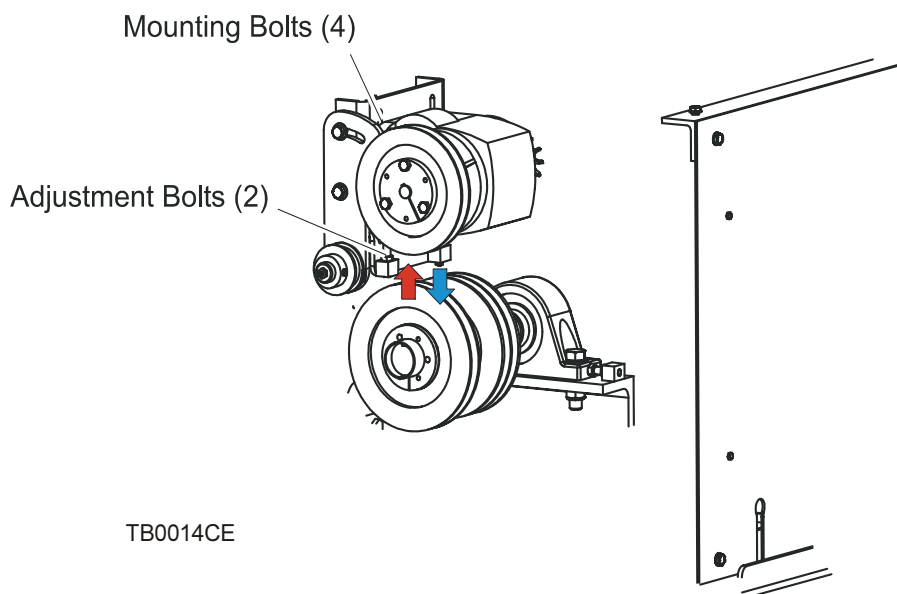





FIG. 4-5





4.4 Checking the Rollers

-  1. Check the feed rollers every 8 hours of operation. Remove any dirt or debris from the rollers. Make sure they spin freely, without much play. Replace the spring-loaded feed rollers as needed.
-  2. Check the press rollers every 8 hours of operation. Clean any debris or sap buildup from the rollers with a wire brush. Replace the press roller bearings if there is any play in the rollers.

4.5 Lubrication

-  1. Clean any debris from the blade drive shaft and every 8 hours of operation. Use a soft cloth to apply a dry graphite daily to ensure resistance-free motion and to prevent surface corrosion.

Also, clean debris from the rack and pinion every 8 hours of operation. Lubricate with dry graphite.

-  2. Lubricate the blade shaft bearings every 200 hours of operation with one to two pumps of lithium-based grease such as Shell Alvania No. 3. Do not overgrease.
-  3. Lubricate the anti-kickback shaft pivots every 200 hours of operation with a high-quality lithium-based grease such as Shell Alvania No. 3.
-  4. Lubricate the press roller bearings every 200 hours of operation with a high-quality lithium-based grease such as Shell Alvania No. 3.
-  5. Lubricate the Setworks dial every 200 hours of operation with a high-quality lithium-based grease such as Shell Alvania No. 3.
-  6. Apply anti-seize lubricant to the surfaces and threads of the blade arbors and locking nuts every blade change ([See Section 4.1](#)).

4.6 Maintaining and Sharpening Anti-Kickback Fingers

This machine has the potential for kick-backs. Kick-backs can cause the board to be suddenly and uncontrollably hurled towards the operator. Such action can result in severe injury or death.

If you are working with frozen boards or with boards that have protruding knots, the chance of kickbacks is increased.

The infeed opening of the Edger is equipped with anti-kickback fingers to help prevent kickback from occurring. To maintain the safety of your Edger, periodically inspect the machine to ensure all anti-kickback fingers are intact and undamaged and have a sharp point. Missing or damaged parts can affect the safety of the machine operator or bystanders and should be replaced immediately. Dulled parts should be re-ground with a hand grinder or replaced.



DANGER! Always ensure that there is a sharp point on the anti-kickback fingers before each use of the Edger.

Be sure anti-kickback fingers are free from obstruction and are in a downward position with lever released. Failure to do so may result in serious injury.

4.7 Alignment



WARNING! Before performing service near moving parts such as blades, pulleys, motors, belts and chains, first turn the engine key switch to the OFF (#0) position and remove the key. If the key is turned on and moving parts activated, serious injury may result.

WARNING! Coastdown Required. Always shut off the engine and allow all moving parts to come to a complete stop before removing any guards or covers. Do NOT operate with any guards or covers

1. Make sure the blade housing cover is open and the blade locking nuts and arbors are loose.
2. Run a string (or straight edge) from the front of the Edger frame to the back. The string should pass directly underneath the "zero" mark on the fixed blade scale and should be parallel to the blades.
3. Move the fixed blade assembly until the inside face of the blade is against the string.

Tighten the fixed blade arbor allen screws to secure the assembly in place.

See Figure 4-6.

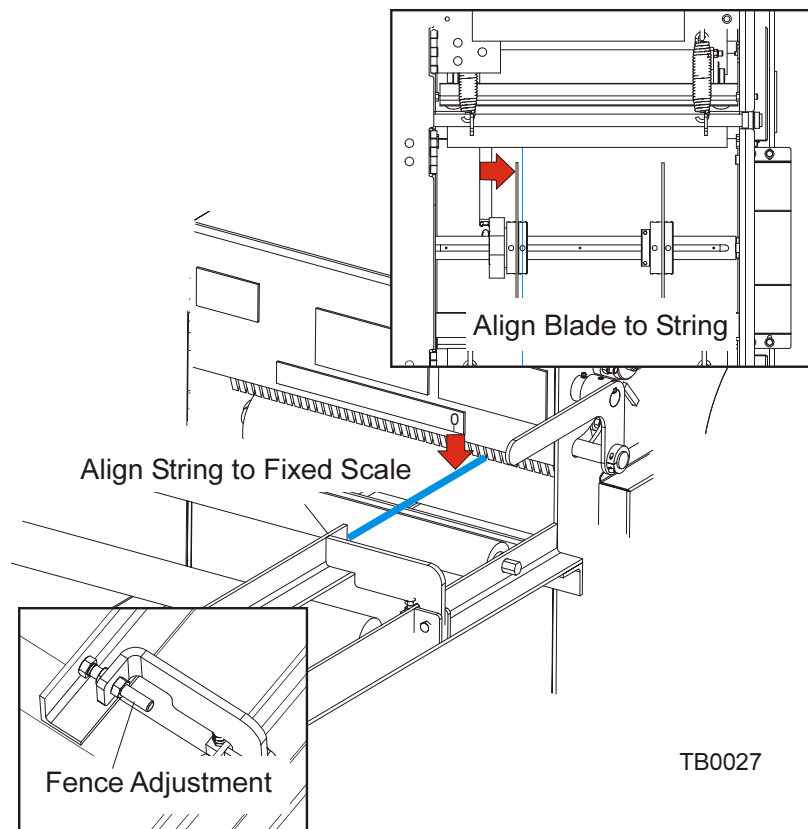

FIG 4-6

4. Next, use the front fence adjustment bolt to adjust the front fence parallel with the string.
5. To position the adjustable blade, set the setworks dial at 3". Measure from the inside of the fixed blade to the inside of the movable blade. If necessary, loosen the movable blade arm and slide the blade assembly on the shaft until the blades are 3" apart. Retighten the blade arm and tighten the arbor allen screws to secure in place.

SECTION 5 TROUBLESHOOTING

5.1 Boards Are Not Self-Feeding



DANGER! Always shut off the engine and allow all moving parts to come to a complete stop before removing any guards or covers.

1. If boards are not self-feeding, increase the tension on the top press rollers.
2. To do this, unbolt and open the blade housing cover.
3. Locate the four horizontal springs which provide tension to the press rollers.
4. Tighten the tension spring eyebolts until sufficient tension is placed on the top press rollers. Always use the lowest amount of tension that still enables boards to feed properly. Too much tension on soft wood can mar the wood.



CAUTION! Do not overtension as this can affect wear life and can cause the rollers to mar the surface of some of the softer woods.

5. Close and secure the blade housing cover.

5.2 Jammed Boards



DANGER! Always shut off the engine and allow all moving parts to come to a complete stop before removing any guards or covers.

1. If a board becomes jammed, temporarily remove press roller tension to release the board.
2. To do this, unbolt and open the blade housing cover.
3. Loosen the nuts on the tension spring eyebolts until enough tension has been released to remove the jammed board.

You may need to use cant hooks to lift the press rollers enough to remove the board. It may also be necessary to lift the anti-kickback fingers by pushing the kickback lever down.

4. Retighten the nuts until the top press rollers are properly tensioned. Always use the lowest amount of tension that still enables boards to feed properly. Too much tension on soft wood can mar the wood.



CAUTION! Do not overtension as this can affect wear life and can cause the rollers to mar the surface of some of the softer woods.

5. Close and secure the blade housing cover.

SECTION 6 PARTS

6.1 How To Use The Parts List

- Go to the appropriate section and locate the part in the illustration.
- Use the number pointing to the part to locate the correct part number and description in the table.
- Parts shown indented under another part are included with that part.
- Parts marked with a diamond (◆) are only available in the assembly listed above the part.

See the sample table below. Sample Part #A01111 includes part F02222-2 and subassembly A03333. Subassembly A03333 includes part S04444-4 and subassembly K05555. The diamond (◆) indicates that S04444-4 is not available except in subassembly A03333. Subassembly K05555 includes parts M06666 and F07777-77. The diamond (◆) indicates M06666 is not available except in subassembly K05555.

6.2 Sample Assembly				
REF	DESCRIPTION (◆ Indicates Parts Available In Assemblies Only)	PART #	QTY.	
	SAMPLE ASSEMBLY, COMPLETE (Includes All Indented Parts Below)	A01111	1	
1	Sample Part	F02222-22	1	
2	Sample Subassembly (Includes All Indented Parts Below)	A03333	1	
	Sample Part (Indicates Part Is Only Available With A03333)	S04444-4	1	◆
3	Sample Subassembly (Includes All Indented Parts Below)	K05555	1	
	Sample Part (Indicates Part Is Only Available With K05555)	M06666	2	◆
4	Sample Part	F07777-77	1	

To Order Parts:

From the continental U.S., call **1-800-448-7881** to order parts. Have your customer number, VIN, and part numbers ready when you call. From other international locations, contact the Wood-Mizer distributor in your area for parts.

6.3 Anti-Kickback & Press Roller

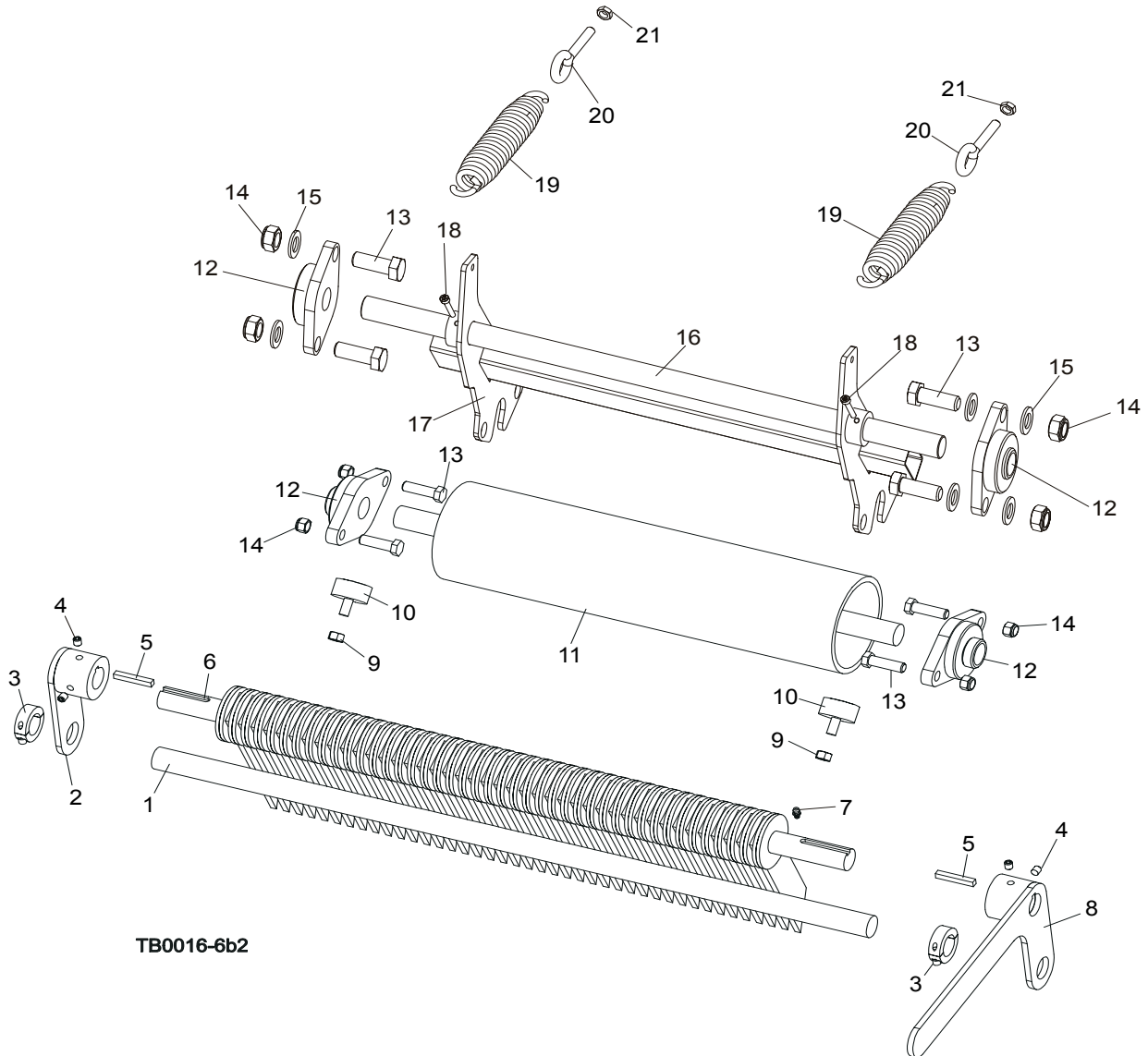

TB0016-6b2

REF	DESCRIPTION (◆ Indicates Parts Available In Assemblies Only)	PART #	QTY.
1	SHAFT, 25X810	089089-1	1
2	PLATE WELDMENT, ANTI-KICKBACK FINGER	089087-1	1
3	COLLAR, 1" LOCKING	089161	2
4	SCREW, M8X8-33H ZINC HEXAGON SOCKET SET	F81014-1	4
5	KEY, 1/4" X 1 11/16"	089229	2
6	SHAFT, ANTI-KICKBACK FINGER	089088-1	1
7	FITTING, STRAIGHT GREASE	086280	1
8	HANDLE WELDMENT, ANTI-KICKBACK RELEASE	089086	1

9	NUT, M10-8-B ZINC	F81033-3	2	
10	BUMP STOP, RUBBER	089147	2	
	PRESS ROLLER ASSEMBLY	089156	1	
11	Roller, Press w/Shaft	038193	1	
12	Bearing, UCFL 205	089124	4	
13	Bolt, M10x35-8.8 Hex Head	F81003-17	8	
14	Nut, M10-8-B Hex Nylon Lock	F81033-1	8	
15	Washer, 17 Zinc Flat	F81058-1	8	
16	SHAFT, PIVOT	089064	1	
17	PIVOT WELDMENT, PRESS ROLLER	089063-1	1	
18	SCREW, M6X16 8.8 ZINC HEX SOCKET HEAD CAP	F81001-21	2	
19	SPRING, 1.5 X 7 X 243	089135	2	
20	TENSIONER, ZINC	089153-1	2	
21	NUT, M10-8-B ZINC HEX NYLON LOCK	F81033-1	2	

6.4 Blade Shaft Assembly

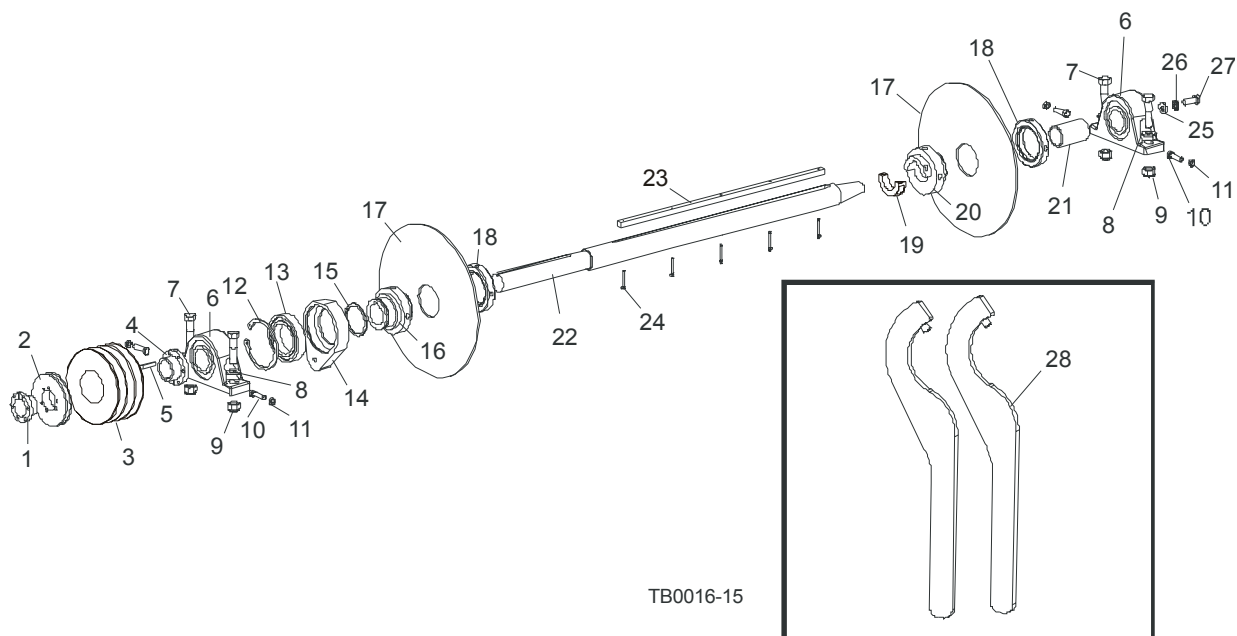

TB0016-15

REF	DESCRIPTION (◆ Indicates Parts Available In Assemblies Only)	PART #	QTY.
1	BUSHING, ZINC-PLATED	089197-1	1
2	PULLEY, 127 MM - ZINC-PLATED	089194-1	1
3	PULLEY	085671	1
4	BUSHING,	085714	1
5	KEY, A12X8X70	089232	1
6	BEARING, UCP 210	089041	2
7	BOLT, M16X60 8.8 FE/ZN5	F81006-12	4
8	WASHER, FLAT 16,3 FE/ZN5 PN-M/82008	F81058-2	4
9	NUT, M16-8-FE/ZN5 HEX NYLON LOCK	F81036-2	4
10	BOLT, M10X50-8.8-FE/ZN5 HEX HEAD FULL THREAD	F81003-4	4
11	NUT, M10-8-B-FE/ZN5	F81033-3	4
	BLADE, MOVING (COMPLETE)		
12	Ring, 110mm Inside Retaining	089166	1
13	Bearing, 6014 2RS	089164	1
14	Housing, Blade Sliding Arbor	089094-1	1
15	Ring, 70mm Outside Retaining	089165	1
16	Arbor, Sliding Blade	089093	1
17	Blade, DNPDe MULTIX 350x76x3,6/18 GM	089144	1
18	Nut, 3-12 Blade Retainer	089092-1	1
	BLADE, FIXED		
17	Blade, DNPDe MULTIX 350x76x3,6/18 GM	089144	1

18	Nut, 3-12 Blade Retainer	089092-1	1	
19	Collar, Locking	089116	1	
20	Arbor, Fixed Blade	089091	1	
21	Bushing, Blade Drive Shaft	089128	1	
22	SHAFT, BLADE DRIVE	089037	1	
23	KEY, BLADE DRIVE SHAFT 12X8X585	089040	1	
24	BOLT,M4X50 -8.8- FE/ZN5 SOCKET HEAD	F81011-32	5	
25	WASHER,13 FE/ZN5 FLAT	F81056-1	1	
26	WASHER, Z12,2 FE/ZN9 SPLIT LOCK	F81056-2	1	
27	BOLT, M12X40-8.8-FE/ZN5 HEX HEAD	F81004-4	1	
28	WRENCH	089209-1	2	

6.5 Covers

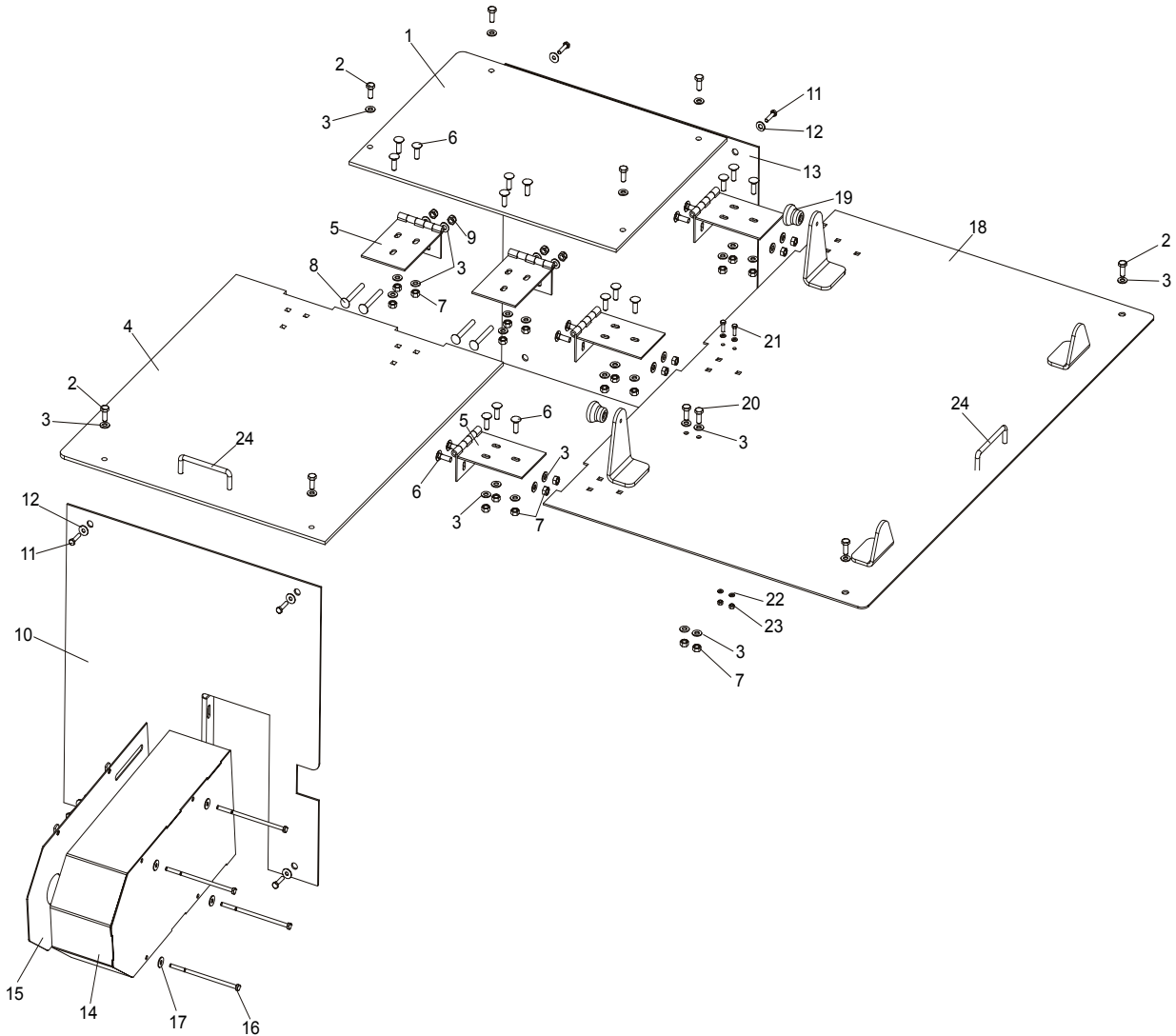

REF	DESCRIPTION (◆ Indicates Parts Available In Assemblies Only)	PART #	QTY.
1	COVER, DRIVE ASSEMBLY	089646-1	1
2	BOLT, M8X20-8.8-B ZINC	F81002-4	8
3	WASHER, 8.4 ZINC STANDARD FLAT	F81054-1	35
4	COVER, DRIVE ASSEMBLY	089645-1	1
5	HINGE, SLOTTED, COMPLETE	089190	5
6	BOLT, M8X20-8.8 ZINC	F81002-11	21
7	NUT, M8-8-B ZINC	F81032-1	21
8	BOLT, M8X65-8.8 ZINC	F81002-24	4
9	NUT, M8-8-B-ZINC NYLON LOCK	F81032-2	4
10	COVER, RIGHT FRONT	089096-1	1

11	BOLT, M6X25-5.8 ZINC	F81001-3	8	
12	WASHER, 6.4 ZINC	F81053-1	8	
13	COVER, RIGHT REAR	089107-1	1	
14	COVER WELDMENT, BELT GUARD	089607-1	1	
15	PLATE WELDMENT, BELT GUARD	089595-1	1	
16	BOLT, M6X136-5.8 ZINC	F81001-51	4	
17	WASHER 6.5 ENLARGED ZINC	F81053-11	4	
18	COVER WELDMENT, TOP LEFT	089109	1	
19	STOP, RUBBER	087825	2	
20	BOLT, M8X20-5.8 ZINC	F81002-1	2	
21	BOLT, M5X16-5.8 ZINC	F81000-51	2	
22	WASHER, 5.3 ZINC	F81052-1	4	
23	NUT, M5-8 ZINC	F81030-1	2	
24	HANDLE, BLADE COVER	P08065	2	

6.6 Feed Table & Return Rollers

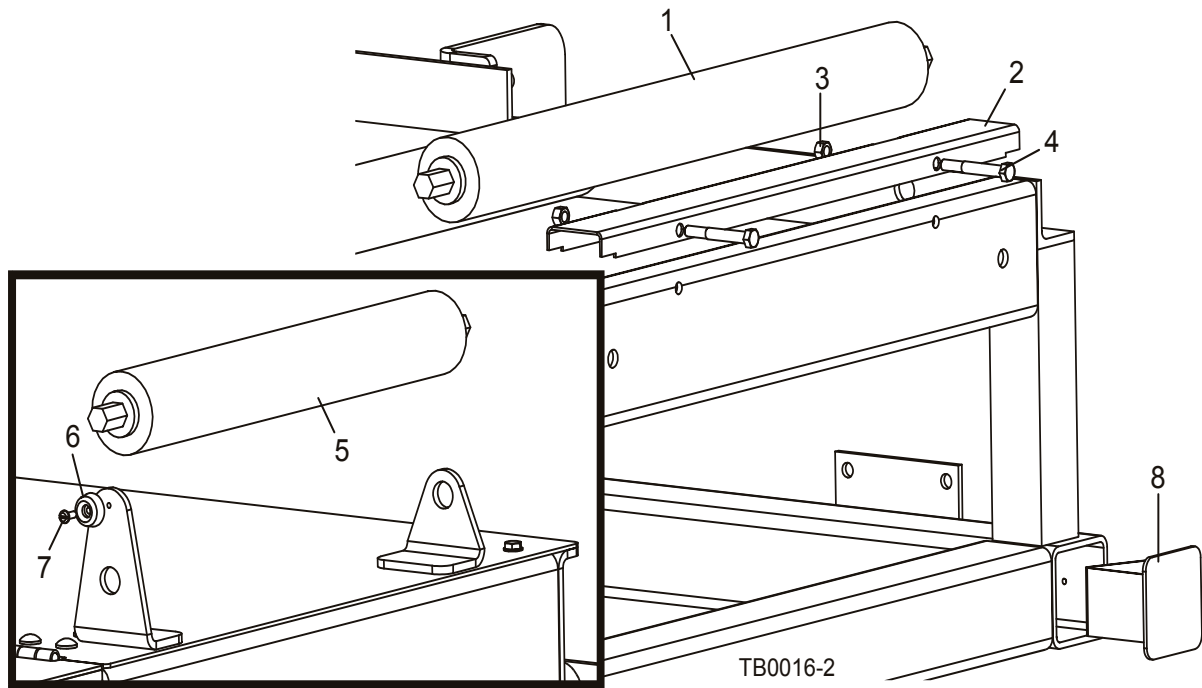

REF	DESCRIPTION (◆ Indicates Parts Available In Assemblies Only)	PART #	QTY.
1	ROLLER, 2 1/2" X 25" FEED	038167	6
2	COVER, 22 3/4" STAINLESS STEEL RAIL	S13012	1
3	NUT, M8-8-B-FE/ZN5 HEX LOCK	F81032-1	2
4	BOLT, M8X70 8.8 FE/ZN5 HEX HEAD	F81002-71	2
5	ROLLER, 63.5/20X500 RETURN	089039-1	2
6	STOP, RUBBER	087825	2
7	SCREW, M5X30-5.8-FE/ZN5 SLOTTED HEX HEAD	F81000-9	2
8	CAP WELDMENT, TUBE END	089143-1	4

6.7 Feed Roller Assemblies & Roller Chain

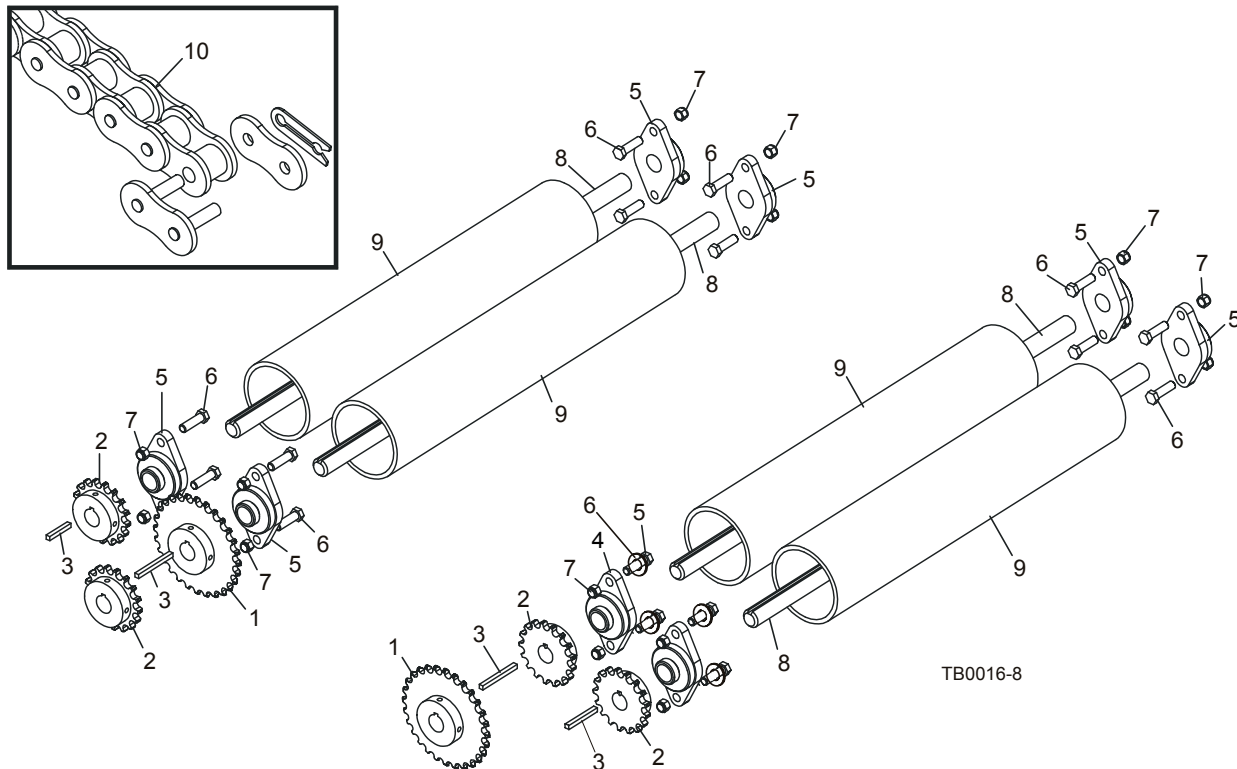

REF	DESCRIPTION (◆ Indicates Parts Available In Assemblies Only)	PART #	QTY.
1	SPROCKET, Z 28 ZINC-PLATED	089099-1	2
2	SPROCKET, ZINC-PLATED	089098-1	4
3	KEY, AB 8X8X70	089231	2
4	BEARING, UCFL 205 FLANGED	089124	8
5	BOLT, M10X35-8.8 FE/ZN5 HEX HEAD	F81003-17	16
6	WASHER 10,5 FE/ZN5	F81055-1	16
7	NUT, M10-8-B -FE/ZN HEX NYLON LOCK	F81033-1	16
8	SHAFT, FEED ROLLER	089059-1	4
9	ROLLER, FEED	038192	4
10	CHAIN, 10B-37WZ+LINK 10BWZ, ROLLER-TO-ROLLER	089177	2
	CHAIN, 10B-65WZ+LINK 10BWZ GEARBOX-TO-ROLLER	089175	2

6.8 Front Guide Fence

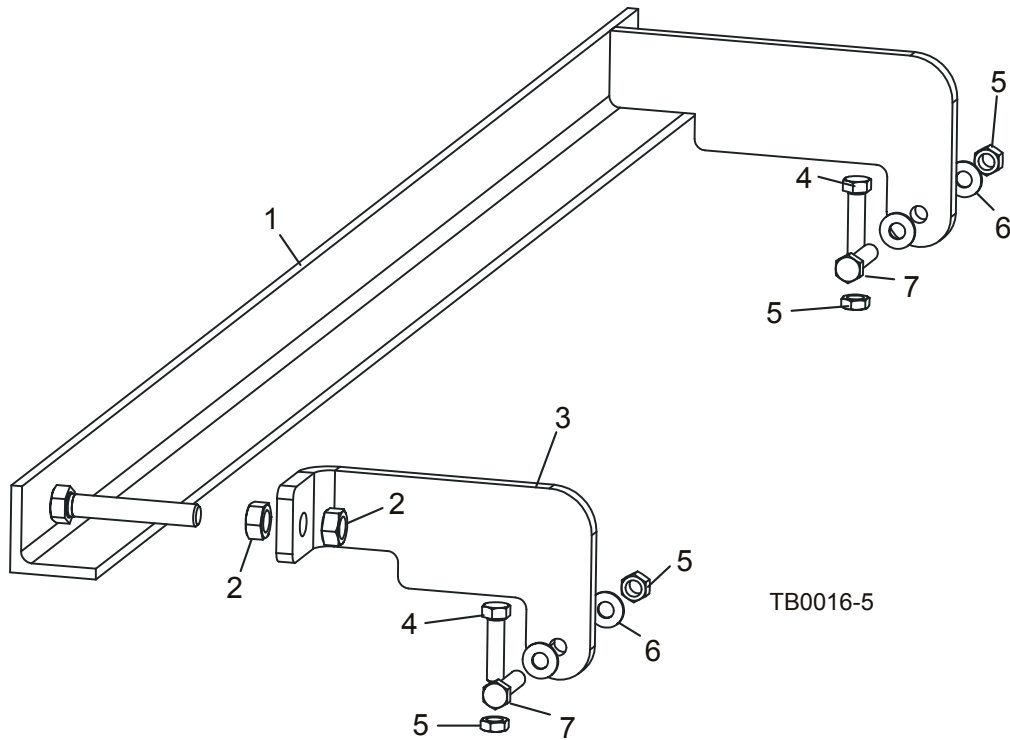

TB0016-5

REF	DESCRIPTION (◆ Indicates Parts Available In Assemblies Only)	PART #	QTY.	
1	FENCE WELDMENT, EDGER FRONT GUIDE	089121-1	1	◆
2	NUT, M12-8 FE/ZN5 HEX	F81034-2	2	◆
3	BRACKET, FRONT GUIDE FENCE MOUNT	089112-1	1	◆
4	BOLT, M10X50-8.8-FE/ZN5 HEX HEAD	F81003-4	2	
5	NUT, M10-8-B-FE/ZN5 HEX JAM	F81033-3	2	
6	WASHER, 10,5 FE/ZN5 FLAT	F81055-1	4	
7	BOLT, M10X130-8.8-FE/ZN5 HEX HEAD	F81003-36	2	

6.9 Gear Box & Idler

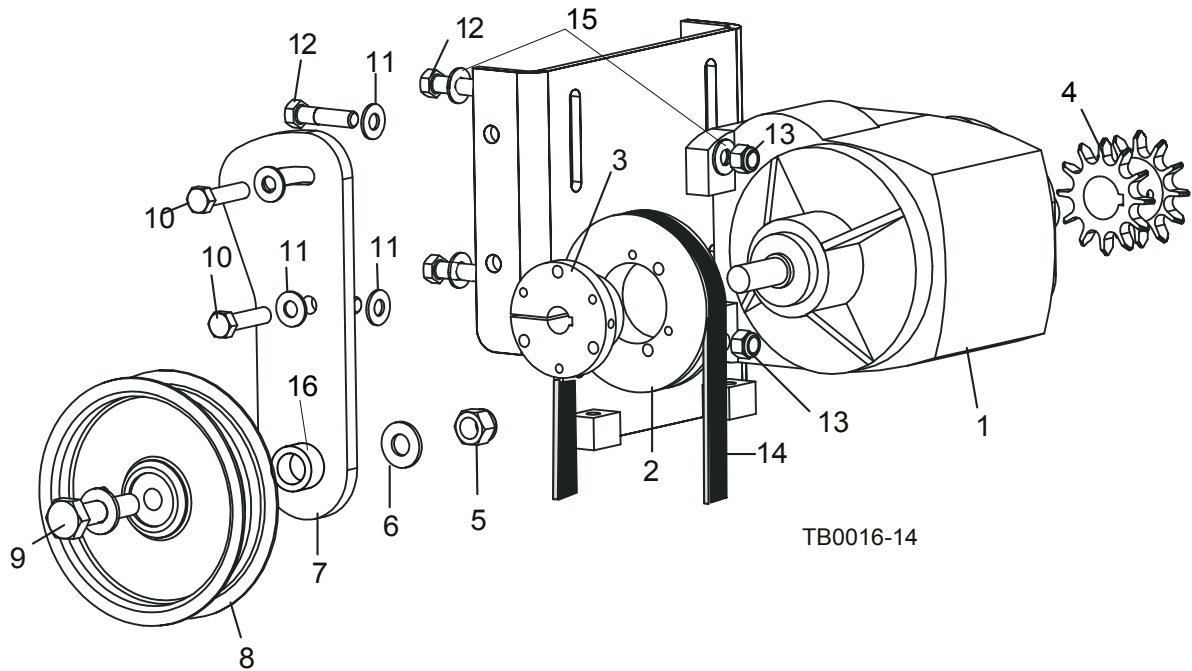

REF	DESCRIPTION (◆ Indicates Parts Available In Assemblies Only)	PART #	QTY.
	REDUCTION GEAR - COMPLETE	089253	1
1	Gear Box, R37AD2	089046	1
2	Pulley 114 zink-plated	089195-1	1
3	Bushing, zink-plated	089196-1	1
4	Sprocket ,2x12 zink-plated	089100-1	1
	BELT TENSIONER	089173	1
5	Nut, M12-8-B Fe/Zn5 Hex NYlon Lock	F81034-1	1
6	Washer, 13 Fe/Zn5 SAE Flat	F81056-1	2
7	Plate, Idler Mount	089198-1	1
8	Pulley, Idler	089066	1
9	Bolt,M12x55-8.8-Fe/Zn5 Hex Head	F81004-12	1
10	BOLT, M10X35-8.8 FE/ZN5 HEX HEAD FULL THREAD	F81003-17	2
11	WASHER,10,5 FE/ZN5 FLAT	F81055-1	6
12	BOLT, M8X35 -8.8-FE/ZN5 HEX HEAD	F81002-13	4
13	NUT, M8-8-B-FEZN5 HEX NYLON LOCK	F81032-2	4
14	BELT, HZ 840	089224	1
15	SPRING WASHER 8,2 FE/ZN9	F81054-4	4
16	TENSIONER BUSHING	089045	4

6 Parts

Motor, Hour Meter & E-Stop (EE15 Only)

6.10 Motor, Hour Meter & E-Stop (EE15 Only)

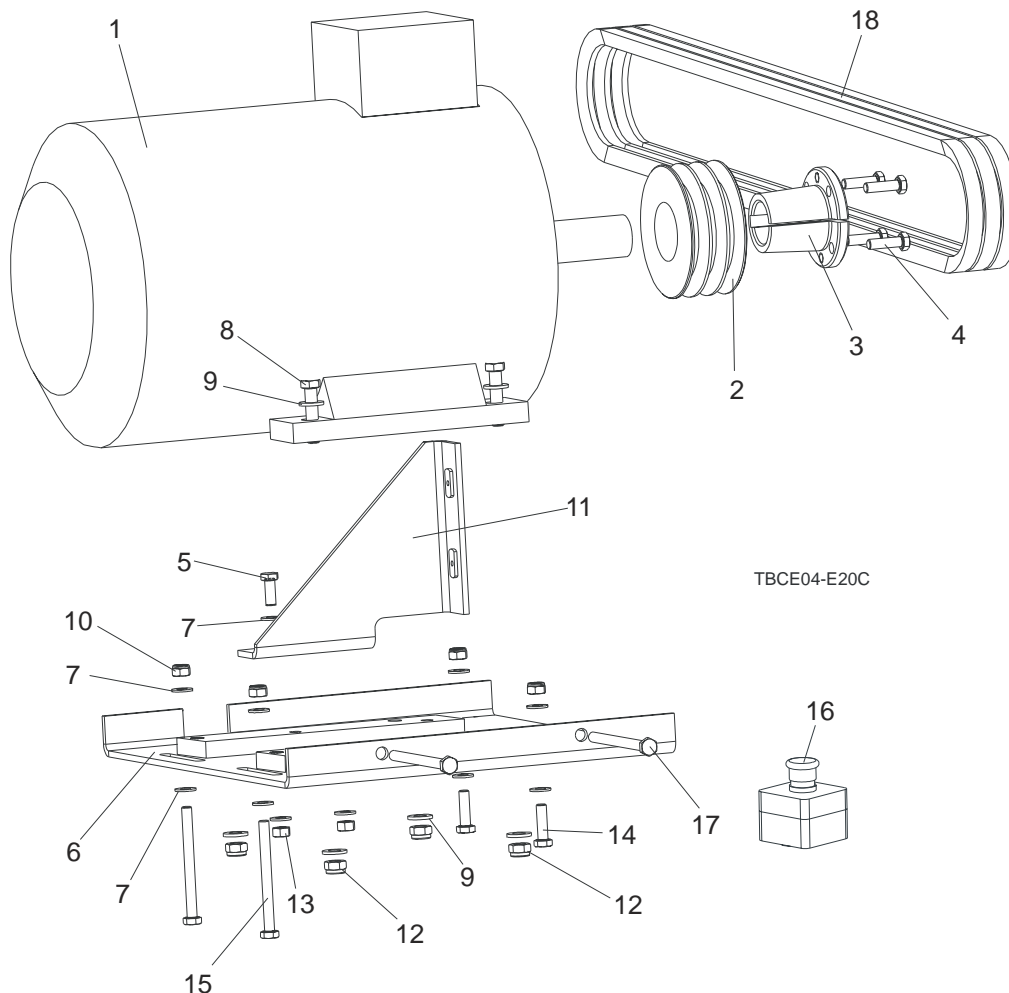

REF	DESCRIPTION (◆ Indicates Parts Available In Assemblies Only)	PART #	QTY.
	ELECTRIC MOTOR ASSEMBLY	089226	1
1	Motor, 11kw (15HP) 3-Phase 380-420v/50Hz (EE15) Sg132S-2PC HM	089049	1
2	Motor Pulley	085671	1
3	Bushing	087066	1
4	Bolt, M10x35-8.8 Fe/Zn5 Hex Head	F81003-17	4
5	Bolt, M10x25-8.8-Fe/Zn5 Hex Head	F81003-11	2
6	Plate, Motor Mount ES15/ES20	091017-1	1
7	Washer, 10,5 Fe/Zn5 Flat	F81055-1	12
8	Bolt, M12x55-8.8-Fe/Zn5	F81004-12	2
9	Washer, 13 Fe/Zn5	F81056-1	6
10	Nut, M10-8-B -Fe/Zn Hex Nylon Lock	F81033-1	4
11	Bracket Weldment, EE20 Belt Guard	089162-1	1
12	Nut, M12-8 Fe/Zn5, Hex Nylon Lock	F81034-2	4

13	Nut, M10-8-B-Fe/Zn5 Hex	F81033-3	5	
14	BOLT, M10X35-8.8 FE/ZN5	F81003-17	2	
15	BOLT, M10X110 8.8 FE/ZN5	F81003-43	1	
16	SWITCH ASSEMBLY, XALK 174 EMERGENCY STOP	E22703-P	1	
17	BOLT, M10X140-8.8-FE/ZN5	F81003-39	2	
18	BELTS ASSEMBLY 3HB2000	089223	1	

6 Parts

Motor, Hour Meter & E-Stop (EE20 Only)

6.11 Motor, Hour Meter & E-Stop (EE20 Only)

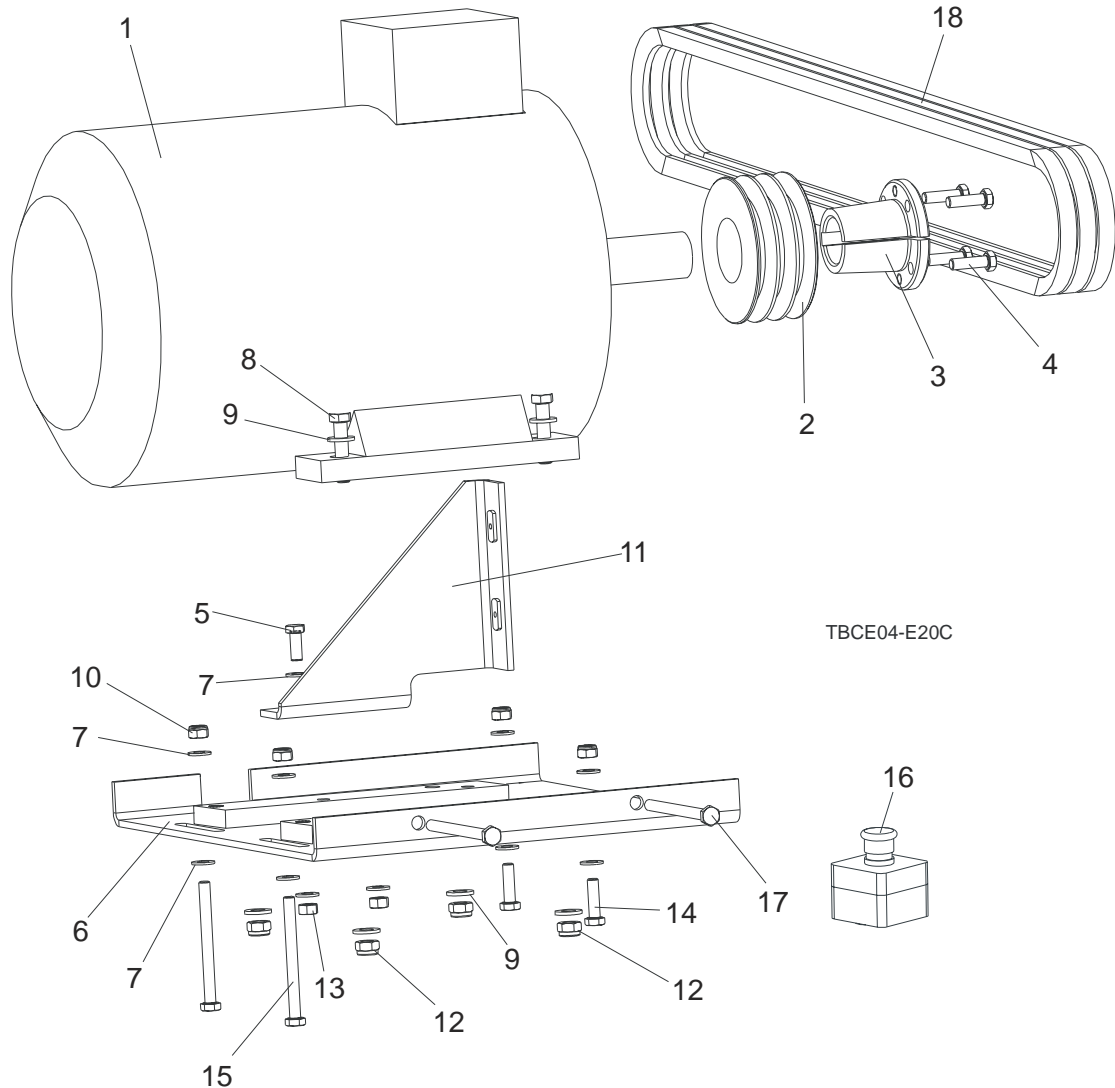

REF	DESCRIPTION (◆ Indicates Parts Available In Assemblies Only)	PART #	QTY.
	ELECTRIC MOTOR ASSEMBLY	ES20	1
1	Motor, 15kw (20HP) 3-Phase 380-420v/50Hz (EE20) Sg160M2B-HM	087929	1
2	Motor Pulley	085671	1
3	Bushing	085714	1
4	Bolt, M10x35-8.8 Fe/Zn5 Hex Head	F81003-17	4
5	Bolt, M10x25-8.8-Fe/Zn5 Hex Head	F81003-11	2
6	Plate, Motor Mount ES15/ES20	091017-1	1
7	Washer, 10,5 Fe/Zn5 Flat	F81055-1	12
8	Bolt, M12x55-8.8-Fe/Zn5	F81004-12	2
9	Washer, 13 Fe/Zn5	F81056-1	6

10	Nut, M10-8-B -Fe/Zn Hex Nylon Lock	F81033-1	4	
11	Bracket Weldment, EE20 Belt Guard	089162-1	1	
12	Nut, M12-8 Fe/Zn5, Hex Nylon Lock	F81034-2	4	
13	Nut, M10-8-B-Fe/Zn5 Hex	F81033-3	5	
14	BOLT, M10X35-8.8 FE/ZN5	F81003-17	2	
15	BOLT, M10X110 8.8 FE/ZN5	F81003-43	1	
16	SWITCH ASSEMBLY, XALK 174 EMERGENCY STOP	E22703-P	1	
17	BOLT, M10X140-8.8-FE/ZN5	F81003-39	2	
18	BELTS ASSEMBLY 3HB2000	089223	1	

6.12 Outfeed Table

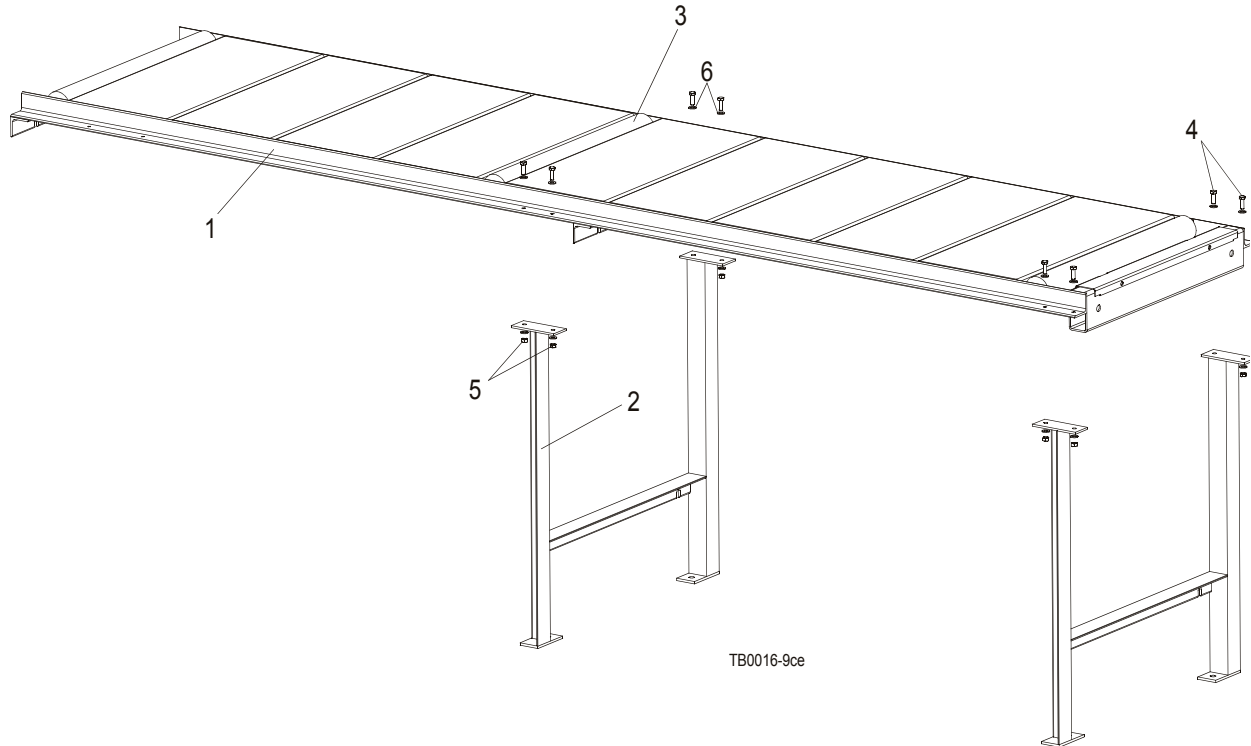

REF	DESCRIPTION (◆ Indicates Parts Available In Assemblies Only)	PART #	QTY.
	OUTFEED TABLE, COMPLETE	089248	1
1	Outfeed Table	089163-1	1
2	Leg, Outfeed Table	089250-1	2
3	Roller, 63.5 x 600 Feed	089044-1	3
4	Bolt M8x25-8.8 -B -Fe/Zn5 Hex Head	F81002-5	8
5	Nut, M8-8 -Fe/Zn5	81032-1	8
6	Washer 8,4 -Fe/Zn5 Flat	F81054-1	16

6.13 Networks Dial & Indicator

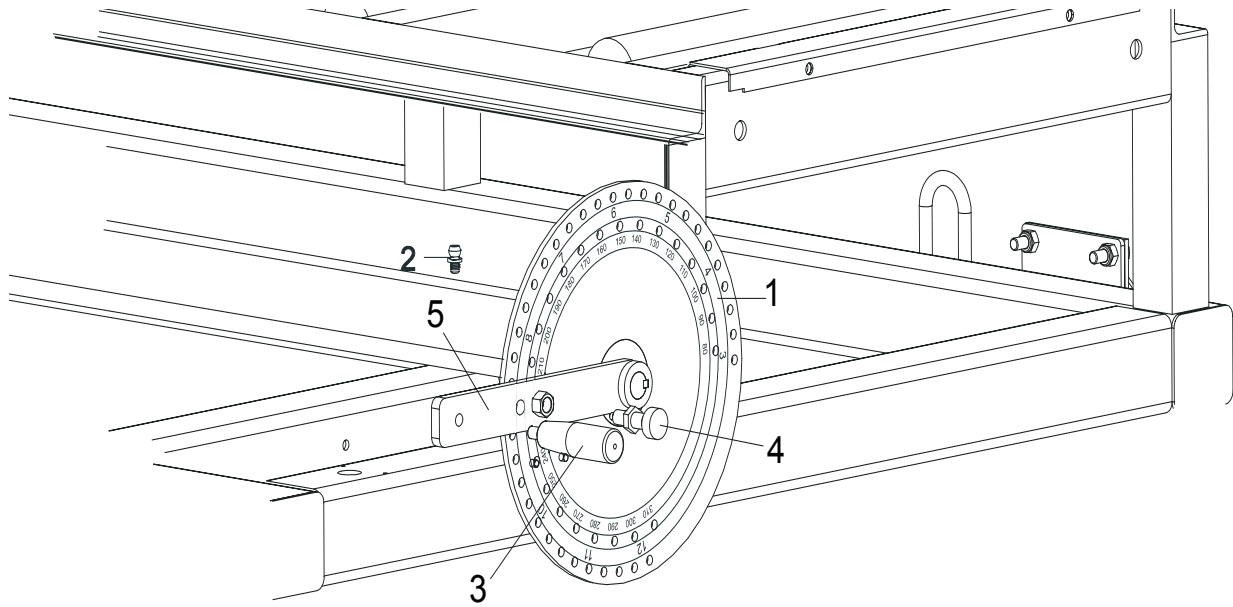

TB0016-1ce

REF	DESCRIPTION (◆ Indicates Parts Available In Assemblies Only)	PART #	QTY.
1	DECAL, EDGER NETWORKS DIAL SCALE (See Section 6.8)		
2	FITTING,M6 PN-M/86002 STRAIGHT GREASE	086280	1
	NETWORKS DIAL, COMPLETE	089255	1
3	Handle, I.301/90+x-M10	086338	1
4	Pin, Networks Dial Locking, GN 617.1-6-A	089242	1
5	Networks dial bracket	089254-1	1

6.14 Setworks Gear & Shaft

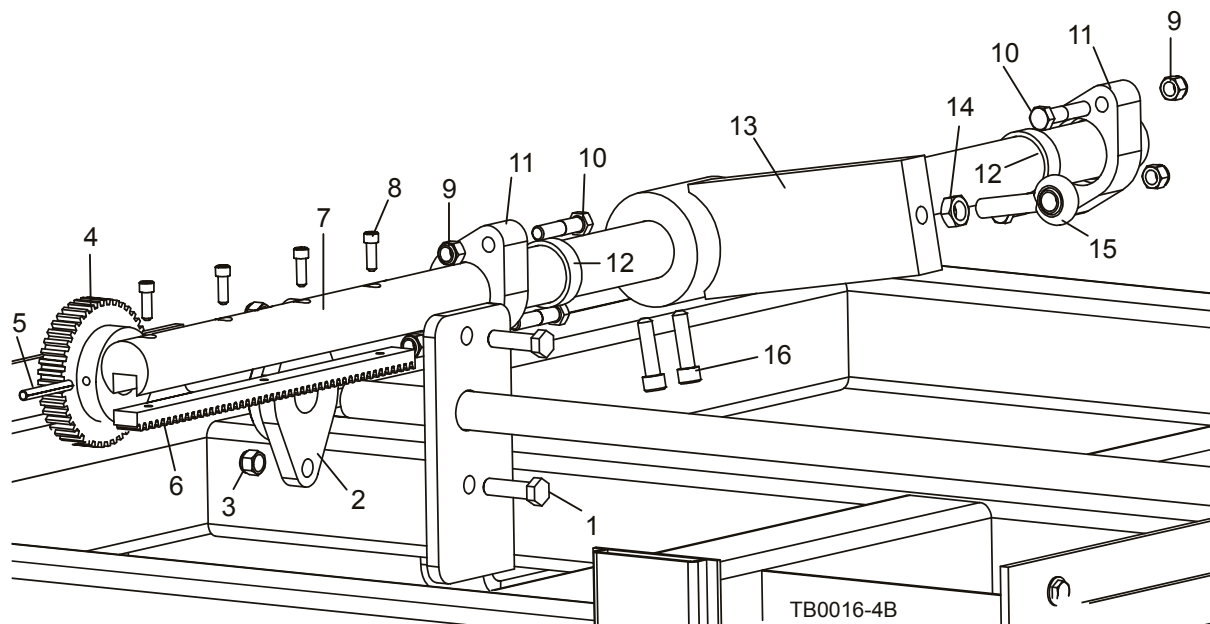

REF	DESCRIPTION (◆ Indicates Parts Available In Assemblies Only)	PART #	QTY.
1	BOLT, M12X40-8.8-FE/ZN5 HEX HEAD	F81004-4	2
2	BEARING, UCFL 205 FLANGED	089124	1
3	NUT, M12-8-B FE/ZN5 HEX NYLON LOCK	F81034-1	2
4	GEAR, SETWORKS TRAVEL, ZINK-PLATED	089054-1	1
5	PIN, 6X50 FE/ZN5	F81045-1	1
	SETWORKS TRAVEL, COMPLETE	089131	1
6	Rack, Setworks Travel	089128	1
7	Shaft, Setworks Gear Travel, chromium plated	089038-1	1
8	BOLT, M6X20 -8.8- FE/ZN5 SOCKET HEAD	F81001-22	4
9	NUT, M10-8-B-FE/ZN5	F81033-3	4
10	BOLT,M10X45-8.8-FE/ZN5 HEX HEAD	F81003-3	4
	SETWORKS SHAFT BEARING - COMPLETE	089134	2
11	Mount, Setworks Shaft Bearing	089047	2
12	Bearing, SR.38/45	089048	2
13	BRACKET WELDMENT, SETWORKS SLIDING	089150-1	1
14	NUT, M12-8-B FE/ZN5 HEX JAM	F81034-1	1
15	ROD END,PGAQR 12 MALE	089127	1
16	BOLT, M10X40 FE/ZN5 SOCKET HEAD	F81003-22	2

6.15 Shaft End Covers

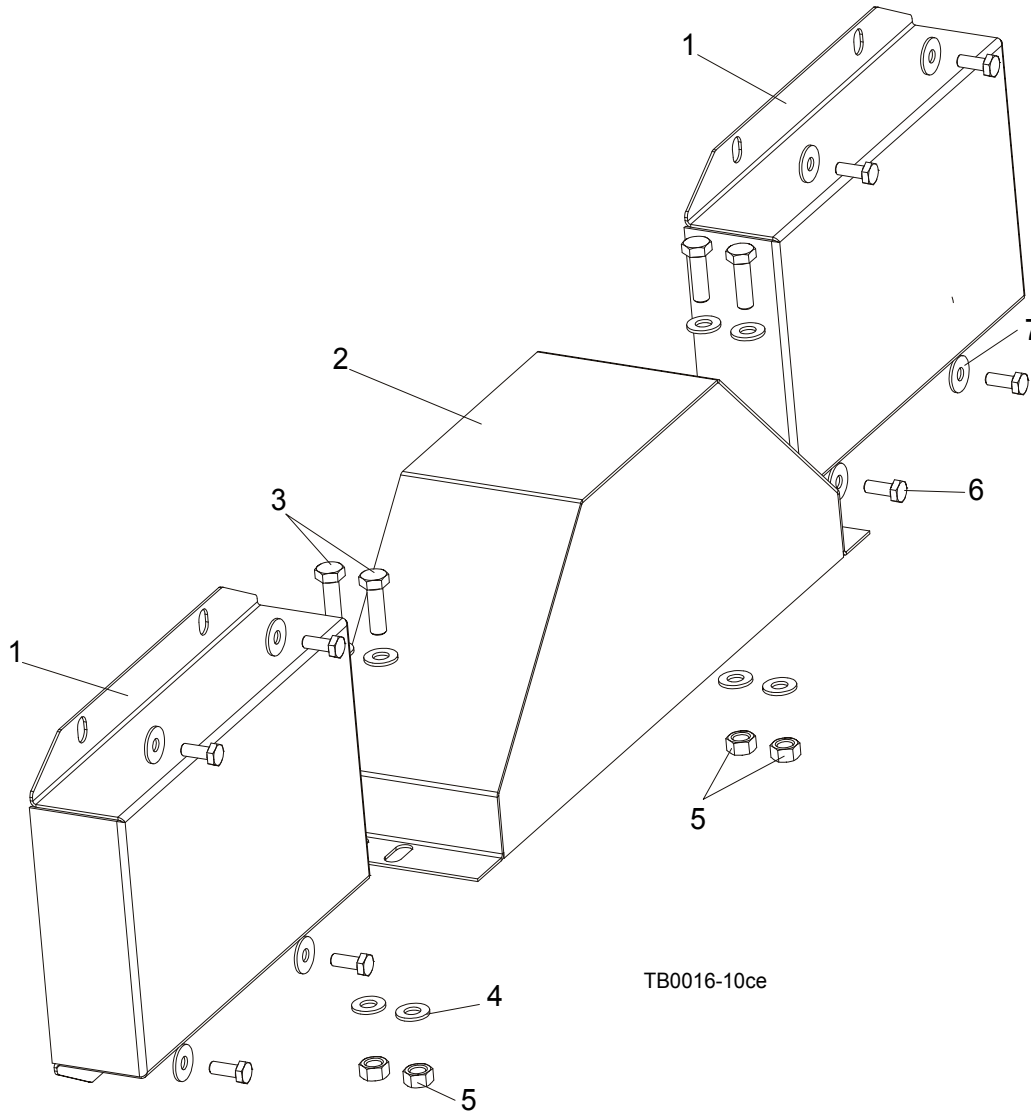

REF	DESCRIPTION (◆ Indicates Parts Available In Assemblies Only)	PART #	QTY.
1	COVER, FLANGED BEARING	089125	2
2	COVER WELDMENT, BEARING	089133-1	1
3	BOLT,M8X25-8.8-B-FE/ZN5 HEX HEAD	F81002-5	4
4	WASHER 8,4-FE/ZN5	F81054-1	4
5	NUT M8-8-B-FE/ZN5	F81032-1	4
6	BOLT M6X16 8.8 FE/ZN5 HEX HEAD	F81001-15	8
7	WASHER 6,5 POW.FE/ZN5	F81053-11	8

6 Parts

Starter Assembly (EE15, EE20 Only)

6.16 Starter Assembly (EE15, EE20 Only)

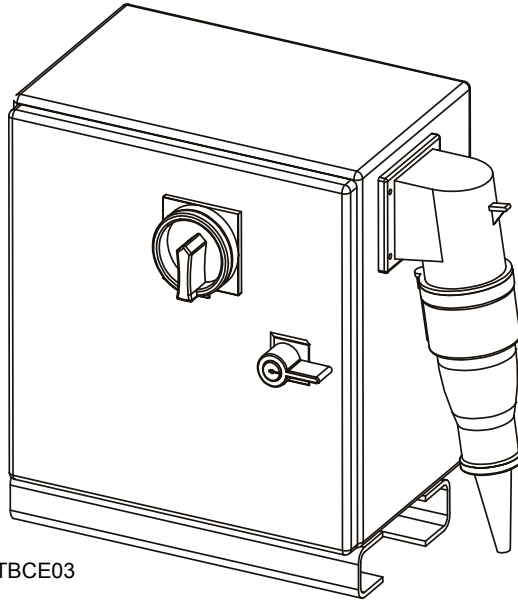

REF	DESCRIPTION (◆ Indicates Parts Available In Assemblies Only)	PART #	QTY.	
	BOX ASSEMBLY, EE15 3-PHASE STARTER (See Section 7 for details)	088050	1	

6.17 Stationary Legs

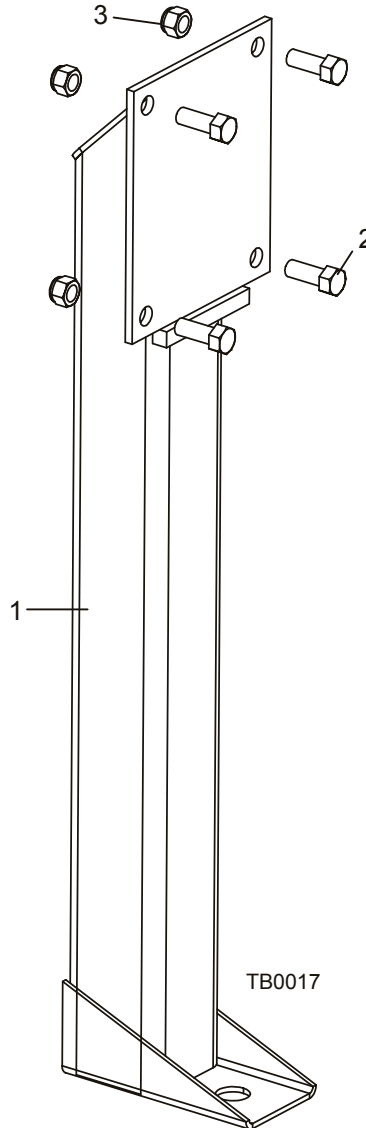

REF	DESCRIPTION (◆ Indicates Parts Available In Assemblies Only)	PART #	QTY.
1	LEG WELDMENT, STATIONARY	W09515	4
2	BOLT, M10X1X25 DIN 933 HEX HEAD	F81003-28	16
3	NUT, M10-8-B -FE/ZN HEX NYLON LOCK	F81033-1	16

SECTION 7 ELECTRICAL INFORMATION

7.1 Wiring Diagrams

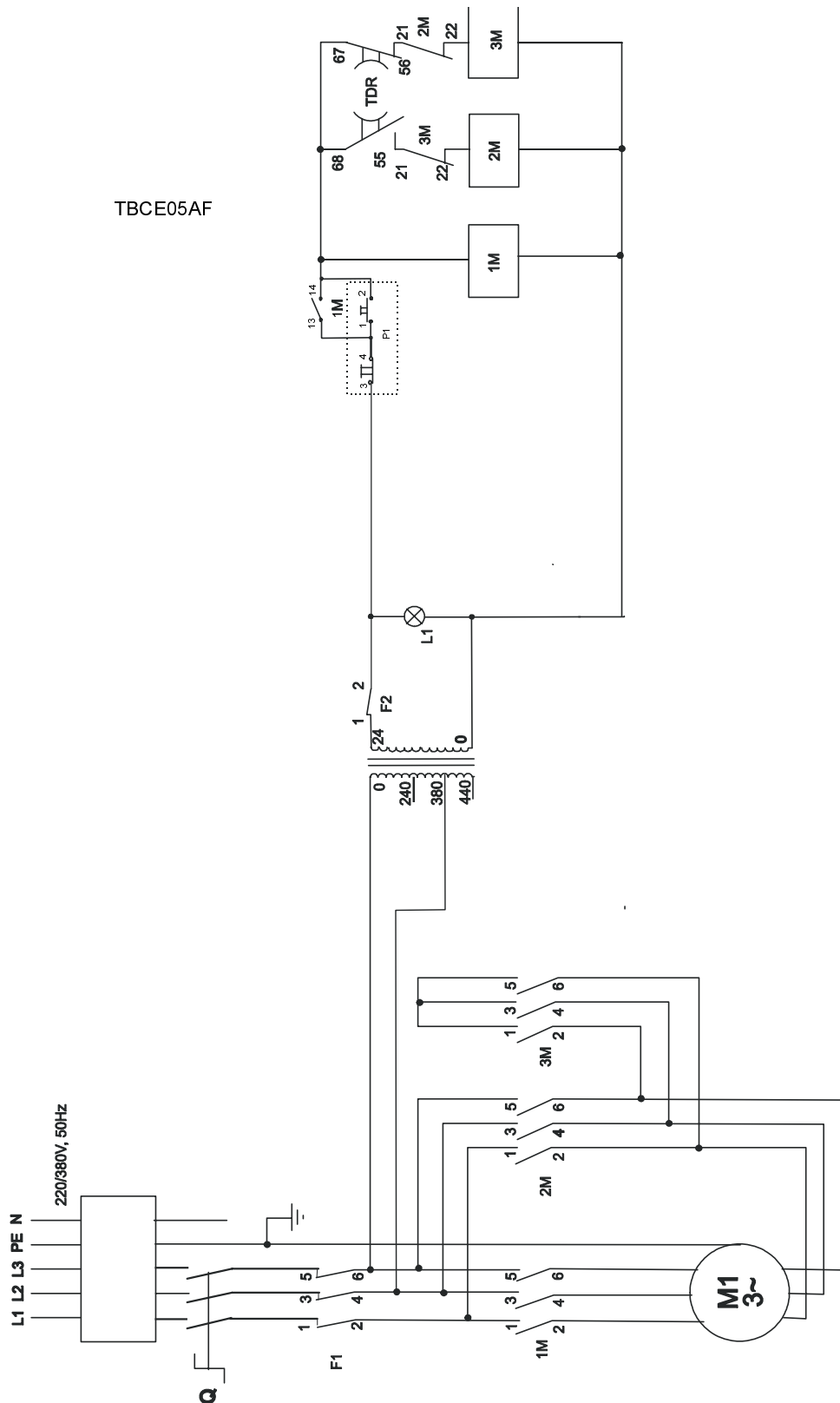
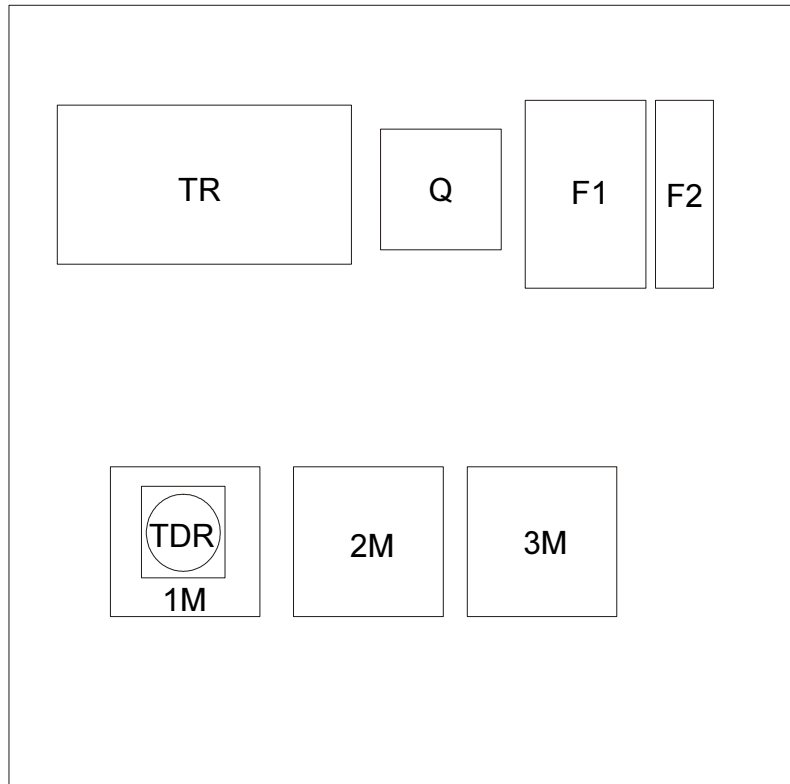

FIG. 7-1 EE15 ELECTRICAL EDGER

7.2 Electrical Component Lists

Component List - EE15				
Item	Mfg. Part No.	Mfg.	Wood-Mizer Part No.	Description
Tr	Toe 160	--	--	Transformer 240/380/440/24
Q	ABB OT32E3	--	--	Disconnecter
F1	GZ1 M32	--	--	Disconnecter, Motor
F2	C60N C2 24396	--	--	Disconnecter, Module
1M	LC1 D1810	--	084307	Contactora
2M	LC1 D1801	--	084306	Contactora
3M	LC1 D0901	--	084305	Contactora
TDR	LR2DS2	--	084037	Relay, Time
P1	XB4 BG33	--	087350	Button, START-STOP
L1	XB4 BV1	--	--	Lamp, Control
M1	Sg132S- 2PC HM	--	088049	Motor, Electric

7.3 Component Layout Diagram



TBCE01

FIG. 7-2