

Wood-Mizer®

Replacement Parts

LX50SC

rev. B1.02



Safety is our #1 concern! Read and understand all safety information and instructions before operating, setting up or maintaining this machine.

Form #851

Table of Contents

Section-Page

SECTION 1	GENERAL INFORMATION	1-1
1.1	How To Use the Parts List.....	1-1
1.2	Sample Assembly	1-1
SECTION 2	BED FRAME PARTS	2-1
2.1	LX50 Bed Frame	2-1
2.2	Basic Bed Frame	2-2
2.3	Bed Section	2-3
2.4	Bed Foot	2-4
2.5	Log Side Support w/Clamp	2-5
2.6	Bed Connection	2-6
2.7	End Stop	2-7
2.8	Cross Brace	2-8
2.9	LX50 Bed Frame Extension	2-9
2.10	LX50 Bed Frame Extension with Log Side Clamp	2-10
2.11	Loading Ramp Assembly 097483	2-11
SECTION 3	SAW HEAD	3-1
3.1	Saw Head	3-2
3.2	Saw Head Decals	3-4
3.3	Blade Height Scale (No. 530667)	3-5
3.4	Up/Down Mast Guide Bracket (No. 532393)	3-6
3.5	Saw Head Rollers (532307, 532308)	3-7
3.6	Cable Guide Roller (Part No. 532306)	3-8
3.7	Band Wheel Assembly	3-9
3.8	Blade Guide Assembly, Drive Side (No. 593254)	3-10
3.9	Blade Guide Assembly, Idle Side (No. 593258)	3-11
3.10	Tensioner Assembly (595710)	3-12
SECTION 4	SAWMILL MAST	4-1
4.1	LX50 Sawmill Mast	4-1
4.2	Horizontal Bearing Assembly	4-3
4.3	Carriage Wheel Assembly	4-4
4.4	Sweeper Assembly	4-5
4.5	Additional Equipment - Left	4-6
4.6	Additional Equipment - Right	4-7
4.7	Blade Tensioner Assembly	4-8
4.8	Up/Down System	4-9
4.9	Winch Crank (No. 532318)	4-10
4.10	Winch Crank Handle (No. 096499)	4-11
4.11	Water Lube Assembly	4-12

Table of Contents

Section-Page

SECTION 5 MOTORS

5-1

5.1	Motor Kit	5-1
5.2	Electric Box Bracket, Starter (included in assy No. 586945-3)	5-3
5.3	Electric Box	5-4
5.4	G14 Engine Kit	5-5
5.5	Clutch Lever	5-8

SECTION 1 GENERAL INFORMATION

1.1 How To Use the Parts List

- Use the index above to locate the assembly that contains the part you need.
- Go to the appropriate section and locate the part in the illustration.
- Use the number pointing to the part to locate the correct part number and description in the table.
- Parts shown indented under another part are included with that part.
- Parts marked with a diamond (◆) are only available in the assembly listed above the part.

See the sample table below. Sample Part #A01111 includes part F02222-2 and subassembly A03333. Subassembly A03333 includes part S04444-4 and subassembly K05555. The diamond (◆) indicates that S04444-4 is not available except in subassembly A03333. Subassembly K05555 includes parts M06666 and F07777-77. The diamond (◆) indicates M06666 is not available except in subassembly K05555.

1.2 Sample Assembly				
REF.	DESCRIPTION (◆ Indicates Parts Available In Assemblies Only)	PART #	QTY	
	Sample Assembly, Complete (Includes All Indented Parts Below)	A01111	1	
1	Sample Part	F02222-22	1	
	Sample Subassembly (Includes All Indented Parts Below)	A03333	1	
2	Sample Part (◆ Indicates Part Is Only Available With A03333)	S04444-4	1	◆
	Sample Subassembly (Includes All Indented Parts Below)	K05555	1	
3	Sample Part (◆ Indicates Part Is Only Available With K05555)	M06666	2	◆
4	Sample Part	F07777-77	1	

To Order Parts:

- From Europe call our European Headquarters and Manufacturing Facility in Kolo, Poland at **+48-63-2626000**. From the continental U.S., call our toll-free Parts hotline at **1-800-525-8100**. Have your customer number, vehicle identification number, and part numbers ready when you call. From other international locations, contact the Wood-Mizer distributor in your area for parts.

Office Hours:

Country	Monday - Friday	Saturday	Sunday
Poland	7-15	Closed	Closed
US	8 a.m.- 5 p.m.	8 a.m.- 12 p.m.	Closed



CAUTION! It is strongly recommended that only original spare parts be used.

SECTION 2 BED FRAME PARTS

2.1 LX50 Bed Frame

530672_001_A
 530672_MANUAL

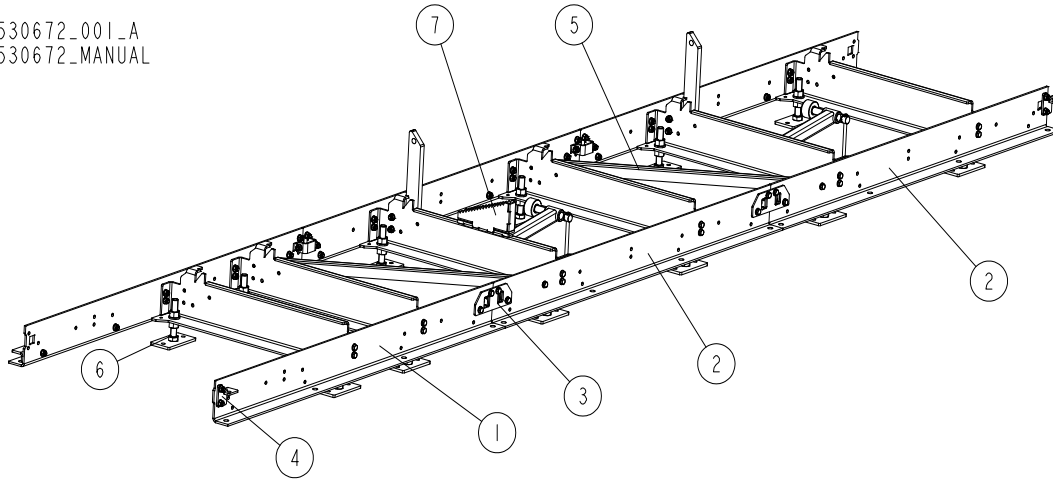

REF.	DESCRIPTION (* indicates parts available in assemblies only)	PART #	QTY
-	BED FRAME, LX50 COMPLETE	530672	1
1	BED FRAME, LX50 BASIC - COMPLETE See Section 2.2	530670	1
2	BED SECTION, LX50 COMPLETE See Section 2.3	530671	2
3	ASSY, BED CONNECTION See Section 2.6	X100-1271	4
4	ASSY, END STOP See Section 2.6	X100-1274	2
5	ASSY, CROSS BRACE See Section 2.6	X100-1276	2
6	FOOT, LT15P BED - COMPLETE	514997	12
7	WLDMT, LOG TAPER	X100-1304	1

2.2 Basic Bed Frame

530670_001
530670_MANUAL

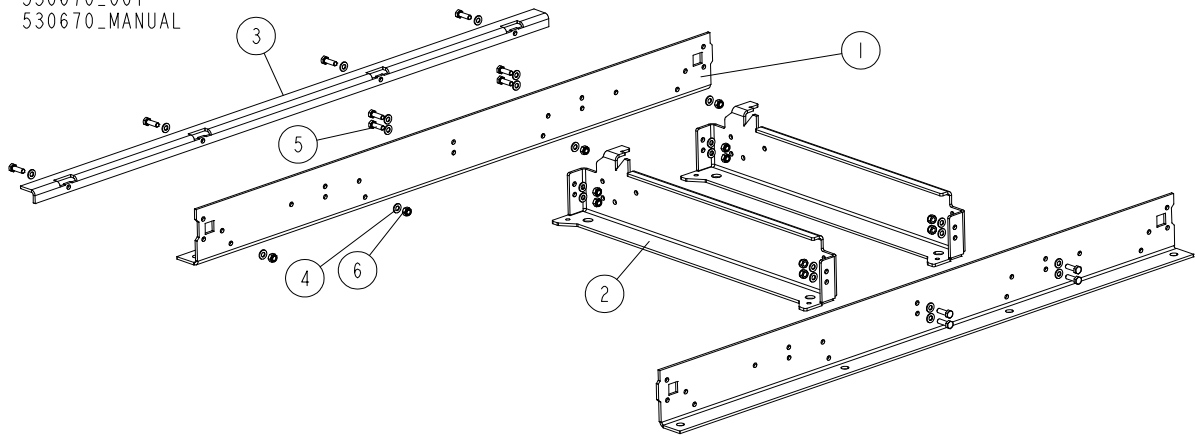

REF	DESCRIPTION (u indicates parts available in assemblies only)	PART #	QTY	
-	BED, LX50 BASIC FRAME - COMPLETE	530670	1	
1	BENT PLATE	X100-1266	2	
2	RAIL, CROSS	550790-1	2	
3	BENT PLATE	X100-1268	1	
4	WASHER, 10.5 FLAT ZINC	F81055-1	24	
5	BOLT, DIN933-M10X30-8.8-A2E HEX HEAD	F81003-111	12	
6	NUT, M10-8-B HEX NYLON ZINC LOCK	F81033-1	12	

2.3 Bed Section

530671_001
 530671_MANUAL

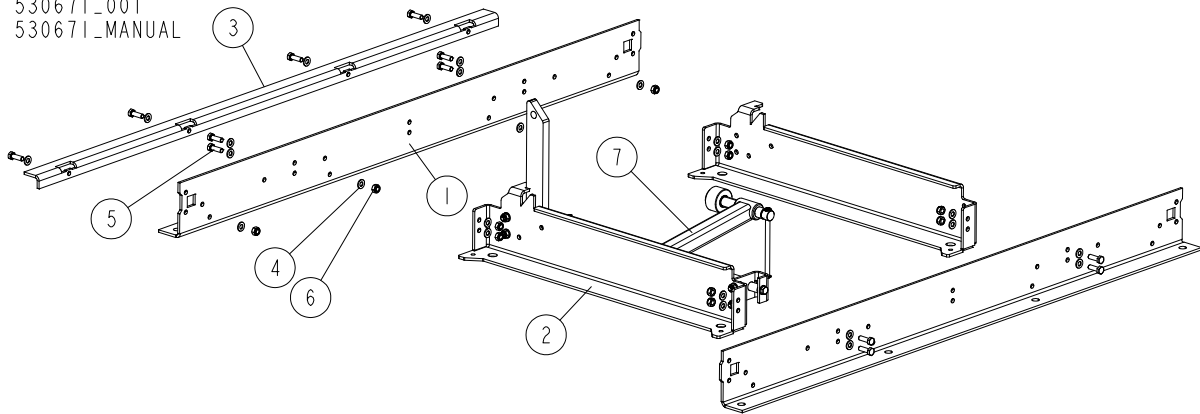

REF	DESCRIPTION (u indicates parts available in assemblies only)	PART #	QTY
-	SECTION, LX50 BED - COMPLETE	530671	1
1	BENT PLATE	X100-1266	2
2	RAIL, CROSS	550790-1	2
3	BENT PLATE	X100-1268	1
4	WASHER, 10.5 FLAT ZINC	F81055-1	24
5	BOLT, DIN933-M10X30-8.8-A2E HEX HEAD	F81003-111	12
6	NUT, M10-8-B HEX NYLON ZINC LOCK	F81033-1	12
7	SUPPORT, LOG SIDE W/CLAMP - COMPLETE	530673	1

2.4 Bed Foot

514997_001
514997_MANUAL

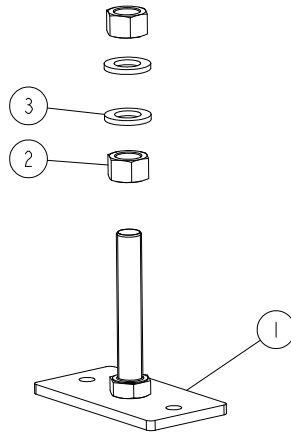

REF.	DESCRIPTION (* indicates parts available in assemblies only)	PART #	QTY	
-	FOOT, LT15P BED - COMPLETE	514997	1	
1	FOOT, LT15 BED WLDMT/ZINC	514996-1	1	
2	NUT, M20-8- HEX ZINC	F81037-1	2	
3	WASHER, 21 FLAT ZINC	F81059-2	2	

2.5 Log Side Support w/Clamp

530673_001
530673_MANUAL

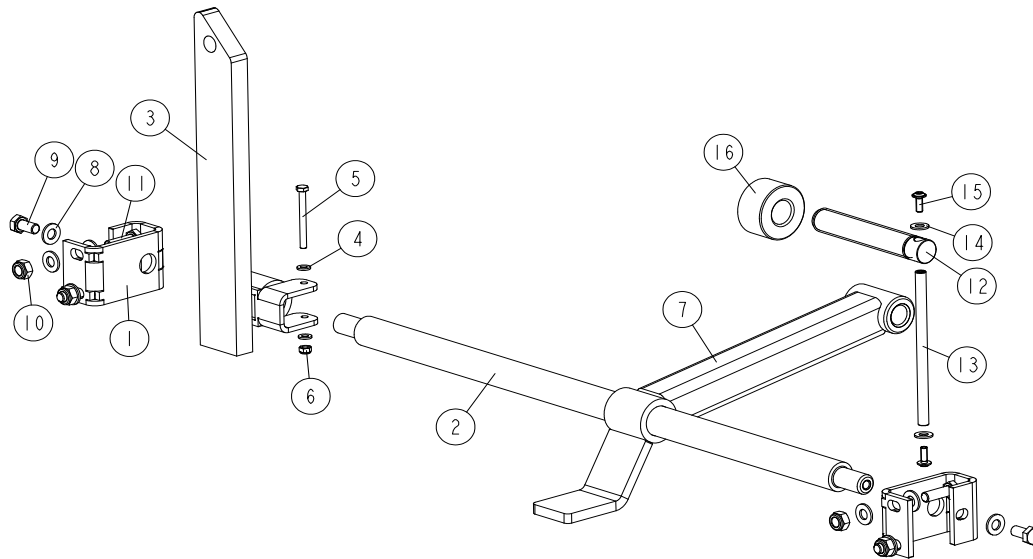

REF	DESCRIPTION (◆ indicates parts available in assemblies only)	PART #	QTY
-	SUPPORT, LOG SIDE W/CLAMP - COMPLETE	530673	1
1	BRACKET, SIDE SUPPORT MOUNTING, LX50 ZIN	530674-1	2
2	ROD, SIDE SUPPORT MAIN	515059-1	1
-	SUPPORT, SIDE LX50 - COMPLETE	530675	1
3	SUPPORT, SIDE LX50 WLDMT/PTD	530676-1	1
4	WASHER, 6.4 FLAT ZINC	F81053-1	2
5	BOLT, M6X60-8.8 HEX HEAD FULL THREAD ZIN	F81001-9	1
6	NUT, M6-8-B HEX NYLON ZINC LOCK	F81031-2	1
7	ARM, CLAMP LX50 ZINC	530701-1	1
8	WASHER, 10.5 FLAT ZINC	F81055-1	10
9	BOLT, ISO 4017-M10X20-8.8-A2E HEX HEAD	F81003-53	2
10	NUT, M10-8-B HEX NYLON ZINC LOCK	F81033-1	4
11	BOLT, DIN933-M10X30-8.8-A2E HEX HEAD	F81003-111	4
-	BOLT, CLAMP - COMPLETE	507563	1
12	BOLT, LOG CLAMP	507463	1
13	ROD, ZINC-PLATED	511923-1	1
14	WASHER, 8.4 FLAT ZINC	F81054-1	2
15	SCREW, M6X16 BN 11252 "BOSSARD".	F81001-24	2
16	CAP, MOUNTING	T00414	1

2.6 Bed Connection

X100-1271_001_A
 X100-1271_MANUAL

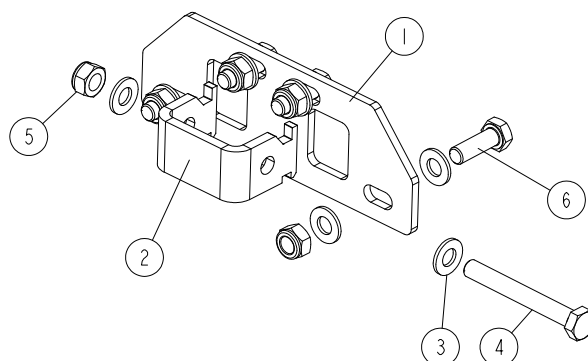

REF.	DESCRIPTION (* indicates parts available in assemblies only)	PART #	QTY
-	ASSY, BED CONNECTION	X100-1271	1
1	FLAT PLATE	X100-1272	1
2	BENT PLATE	X100-1273	1
3	WASHER, 10.5 FLAT ZINC	F81055-1	10
4	BOLT, M10X80-8.8 HEX HEAD ZINC	F81003-50	1
5	NUT, M10-8-B HEX NYLON ZINC LOCK	F81033-1	5
6	BOLT DIN 933-M10X30 8.8-A2E	F81003-111	4

2.7 End Stop

X100-1274_001
 X100-1274_MANUAL

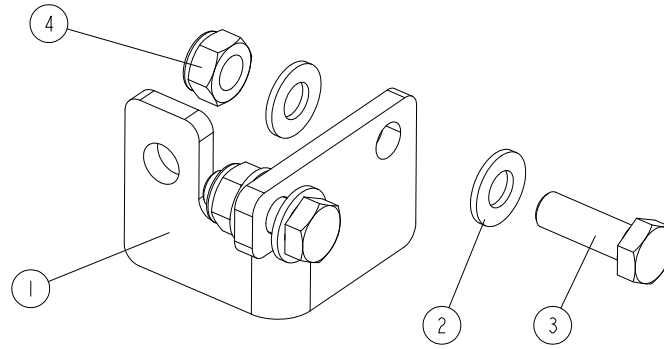

REF.	DESCRIPTION (* indicates parts available in assemblies only)	PART #	QTY	
-	ASSY, END STOP	X100-1274	1	
1	BENT PLATE	X100-1275	1	
2	WASHER, 10.5 FLAT ZINC	F81055-1	4	
3	BOLT, M10X30-8.8 HEX HEAD FULL THREAD ZINC	F81003-2	2	
4	NUT, M10-8-B HEX NYLON ZINC LOCK	F81033-1	2	

2 BED FRAME PARTS

Cross Brace

2.8 Cross Brace

X100-1276_001
X100-1276_MANUAL

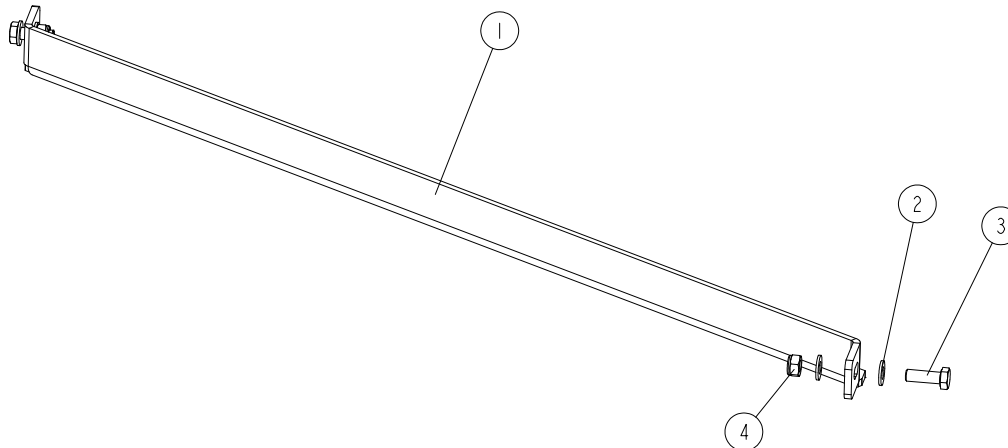

REF.	DESCRIPTION (* indicates parts available in assemblies only)	PART #	QTY
-	ASSY, CROSS BRACE	X100-1276	1
1	BENT PLATE	X100-1277	1
2	WASHER, 10.5 FLAT ZINC	F81055-1	4
3	BOLT, M10X30-8.8 HEX HEAD FULL THREAD ZINC	F81003-2	2
4	NUT, M10-8-B HEX NYLON ZINC LOCK	F81033-1	2

2.9 LX50 Bed Frame Extension

LX50_EXT_001
LX50_EXT_MANUAL

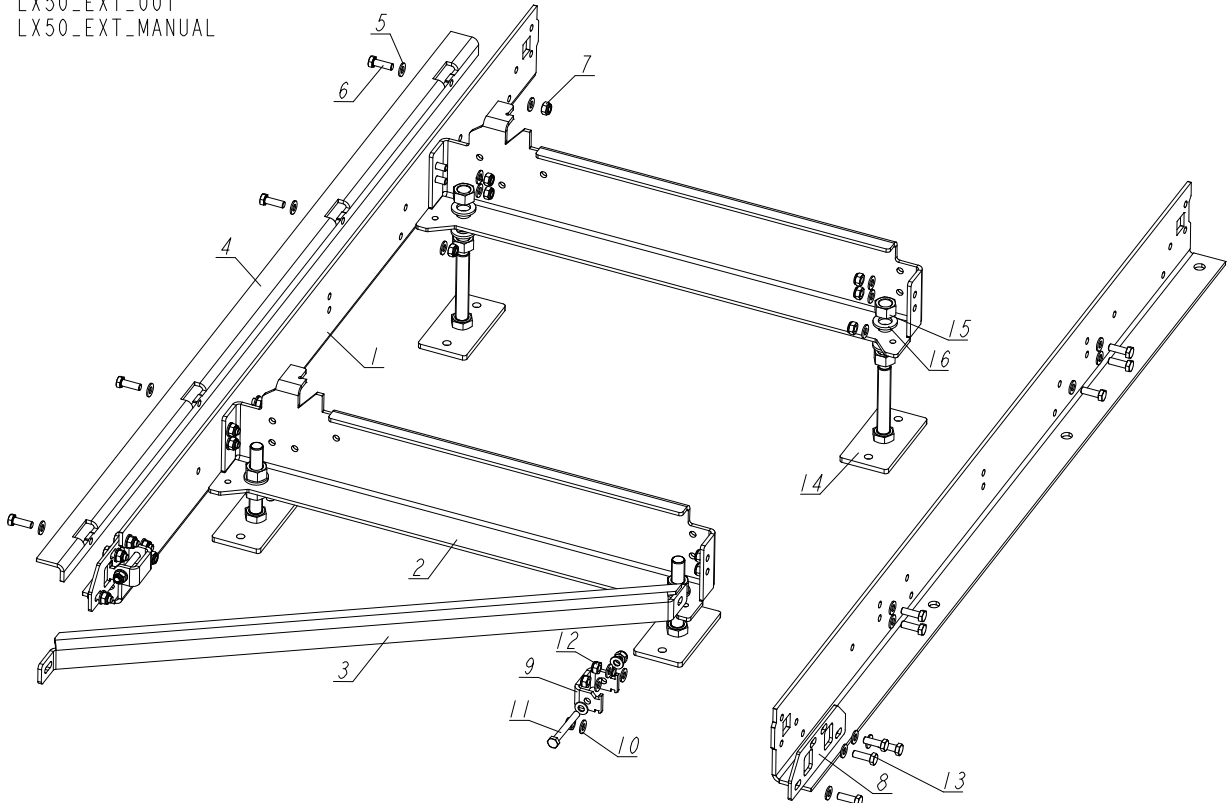

REF.	DESCRIPTION (* indicates parts available in assemblies only)	PART #	QTY
-	LX50 EXTENSION	LX50-EXT	1
1	BENT PLATE	X100-1266	2
2	BENT PLATE	X100-1267	2
3	BENT PLATE	X100-1277	1
4	BENT PLATE	X100-1268	1
5	WASHER, 10.5 FLAT ZINC	F81055-1	28
6	BOLT, DIN933-M10X30-8.8-A2E HEX HEAD FULL THREAD	F81003-111	14
7	NUT, M10-8-B HEX NYLON ZINC LOCK	F81033-1	14
-	ASSY, BED CONNECTION	X100-1271	2
8	FLAT PLATE	X100-1272	1
9	BENT PLATE	X100-1273	1
10	WASHER, 10.5 FLAT ZINC	F81055-1	10
11	BOLT, M10X80-8.8 HEX HEAD ZINC	F81003-50	1
12	NUT, M10-8-B HEX NYLON ZINC LOCK	F81033-1	5
13	BOLT, DIN933-M10X30-8.8-A2E HEX HEAD FULL THREAD	F81003-111	4
-	FOOT, LT15 BED COMPLETE	514997	4
14	FOOT WELDMENT, LT15 ZINC-PLATED	514996-1	1
15	NUT, M20-8 HEX ZINC	F81037-1	2
16	WASHER, 21 FLAT ZINC	F81059-2	2



BED FRAME PARTS

LX50 Bed Frame Extension with Log Side Clamp

2.10 LX50 Bed Frame Extension with Log Side Clamp

LX50_EXT_S_001
LX50_EXT_S_MANUAL

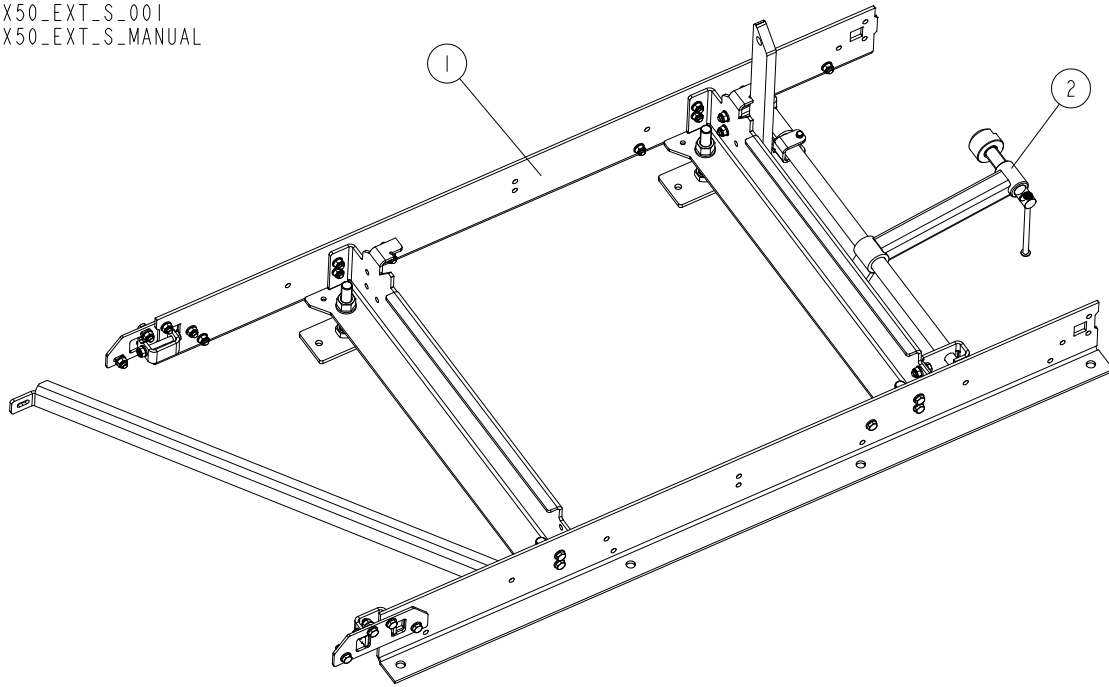

REF.	DESCRIPTION (* indicates parts available in assemblies only)	PART #	QTY	
-	LX50 EXTENSION WITH LOG SIDE CLAMP	LX50-EXT-S	1	
1	LX50 EXTENSION	LX50-EXT	1	
2	LOG SIDE SUPPORT W/CLAMP, LX50 - COMPLETE	530673	1	

2.11 Loading Ramp Assembly 097483¹

097483_001
097483_MANUAL

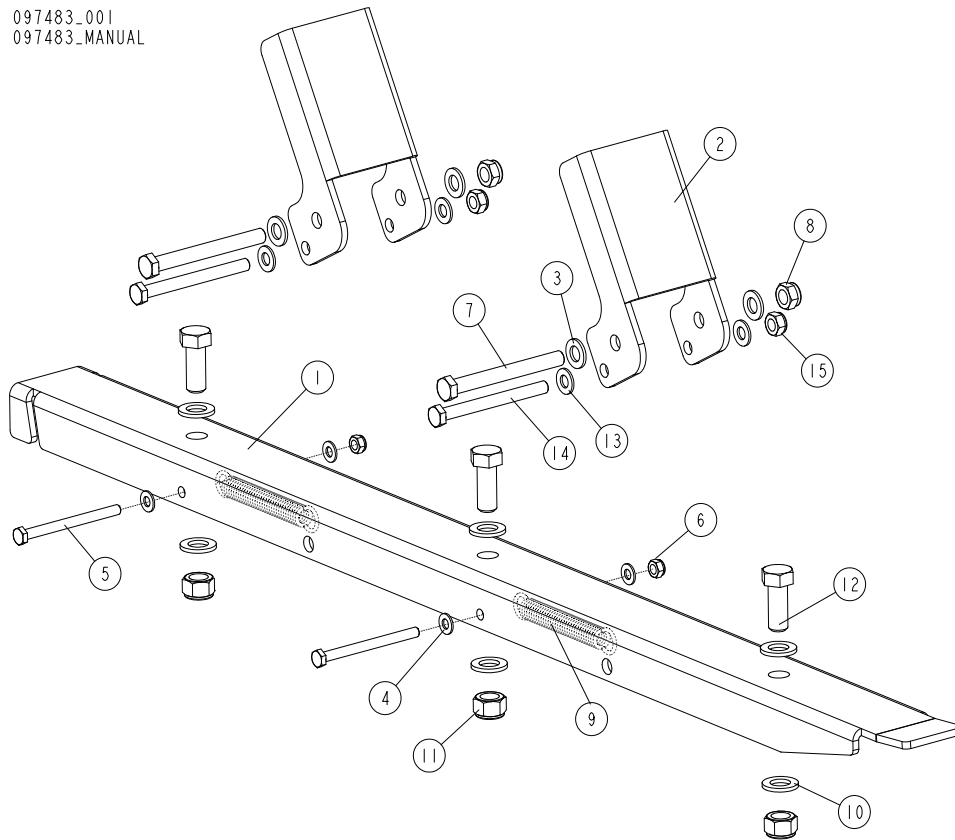

REF.	DESCRIPTION (* indicates parts available in assemblies only)	PART #	QTY
-	RAMP ASSEMBLY, LOADING	097483	1
1	PLATE, LT10 LOADING RAMP - MAIN	097481-1	1
2	BRACKET, LOG LOADING STOP	097482-1	2
3	WASHER, 13 FLAT ZINC	F81056-1	4
4	WASHER, 8.4 FLAT ZINC	F81054-1	4
5	BOLT, M8X100-8.8 HEX HEAD ZINC	F81002-23	2
6	NUT, M8-8-B HEX NYLON ZINC LOCK	F81032-2	2
7	BOLT, M12X115-8.8-B HEX HEAD ZINC	F81004-33	2
8	NUT, M12-8 DIN 982 HEX NYLON ZINC LOCK	F81034-2	2
9	SPRING, N1.9XN14.2X104	091865	2
10	WASHER, 17 SPLIT LOCK ZINC	F81058-1	6
11	NUT, M16-8 HEX NYLON ZINC LOCK	F81036-2	3
12	BOLT, M16X40-8.8 HEX HEAD FULL THREAD ZINC	F81006-13	3
13	WASHER, 10.5 FLAT ZINC	F81055-1	4
14	BOLT, M10X110-8.8 HEX HEAD ZINC	F81003-43	2
15	NUT, M10-8-B HEX NYLON ZINC LOCK	F81033-1	2

1.(2x097483) included in assembly 586967



SECTION 3 SAW HEAD

3.1 Saw Head

594370_001_A
594370

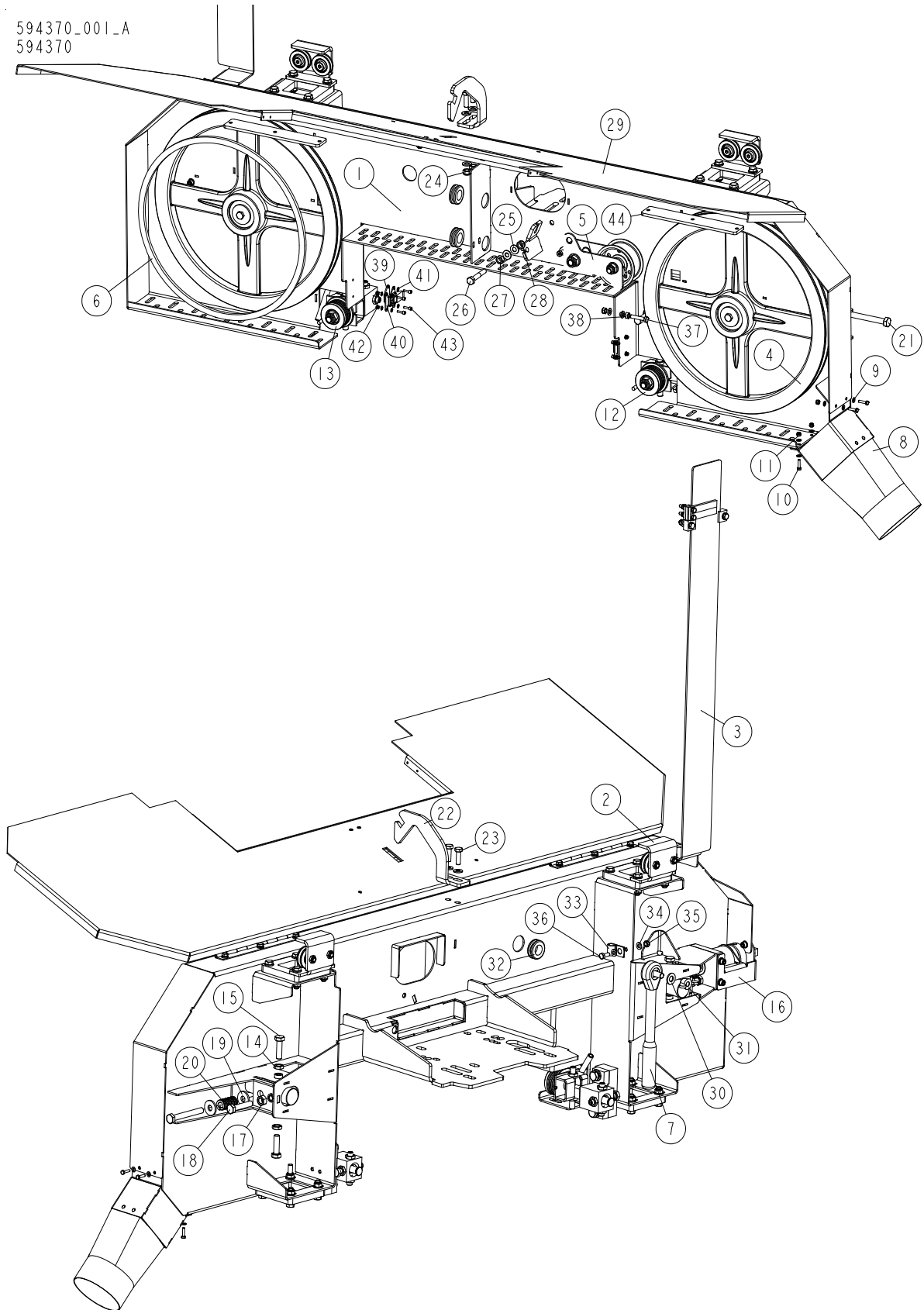

REF	DESCRIPTION (◆ indicates parts available in assemblies only)	PART #	QTY
-	SAW HEAD, LX50 - COMPLETE	594370	1
1	SAW HEAD,LX50SA	557344-1	1
2	BRACKET ASSEMBLY, UP/DOWN MAST GUIDE	532393	1
3	SCALE, BLADE HEIGHT - COMPLETE See Section 3.3	530667	1
4	ASSY, BANDWHEEL SHAFT See Section 3.7	X100-961	2
5	TENSIONER, LX50SA ASSY.	595710	1
6	BELT, B47.5	X100-900	1
7	WRENCH, LT20 BLADE TENSION	091620	1
8	ASSY, SAWDUST CHUTE	X100-1288	1
9	WASHER, 4.3 FLAT ZINC	F81051-2	8
10	BOLT, M4X16 5.8 HEX HEAD FULL THREAD ZIN	F81011-6	4
11	NUT, M4-B HEX NYLON ZINC LOCK	F81029-1	4
12	BLADE GUIDE ASSEMBLY, DRIVE SIDE See Section 3.8	593254	1
13	BLADE GUIDE ASSEMBLY, IDLE SIDE See Section 3.9	593258	1
14	NUT, M10X1-04-ST-A2E ISO8675 THIN	F81033-10	2
15	BOLT,M10X35-8.8 HEX HEAD FULL THREAD ZIN	F81003-17	2
16	TENSIONER ASSEMBLY See Section 4.7	X100-1246	1
17	NUT, M10-8-B-HEX ZINC	F81033-3	1
18	BOLT, M10X50MM,HEX HEAD FULL THREAD ZINC	F81003-4	1
19	WASHER, 10.5 SPECIAL FLAT ZINC	F81055-6	2
20	SPRING, 3/4 O.D.X 1 1/2 DIE	034430	1
21	BOLT, M10X80-8.8 HEX HEAD ZINC	F81003-50	1
22	ASSY, COVER LATCH	X100-1154	1
23	BOLT, M8X25-8.8-B HEX HEAD FULL THREAD Z	F81002-5	2
24	NUT, M8-8-B HEX NYLON ZINC LOCK	F81032-2	2
25	WASHER, 8.4 FLAT ZINC	F81054-1	4
26	BOLT, M8X50 HH	F81002-10	2
27	NUT, M8-8-B HEX ZINC	F81032-1	2
28	NUT, M8-8-B HEX NYLON ZINC LOCK	F81032-2	2
29	COVER, LX50SA FRONT	557348	1
30	WASHER, 10.5 FLAT ZINC	F81055-1	1
31	NUT, M10 WING	F81033-8	1
32	GROMMET, RUBBER 3/4 ID	025247	3
33	CLAMP, 1/2" EMT COATED	P07584	1
34	WASHER, 6.4 FLAT ZINC	F81053-1	4
35	NUT, M6-8-B HEX NYLON ZINC LOCK	F81031-2	2
36	BOLT M6X16 HH ZC FT 8.8 DIN 933	F81001-15	1
37	BOLT, M6X30-8.8 HEX HEAD FULL THREAD ZIN	F81001-8	1
38	NUT, M6 8 HEX ZINC	F81031-1	1
39	WASHER	550822	2
40	HOOK FASTENER, TLE.Z-15/52+R	550743	2
41	WASHER, 3.2 FLAT ZINC	F81050-2	16
42	NUT, M3-6-HEX NYLON ZINC LOCK	F81028-2	8
43	BOLT, M3X12-8.8 FE/ZN PN-EN ISO 4762	F81011-30	8
44	PLATE WELDMENT, COVER MOUNT	086701-1	2

3.2 Saw Head Decals

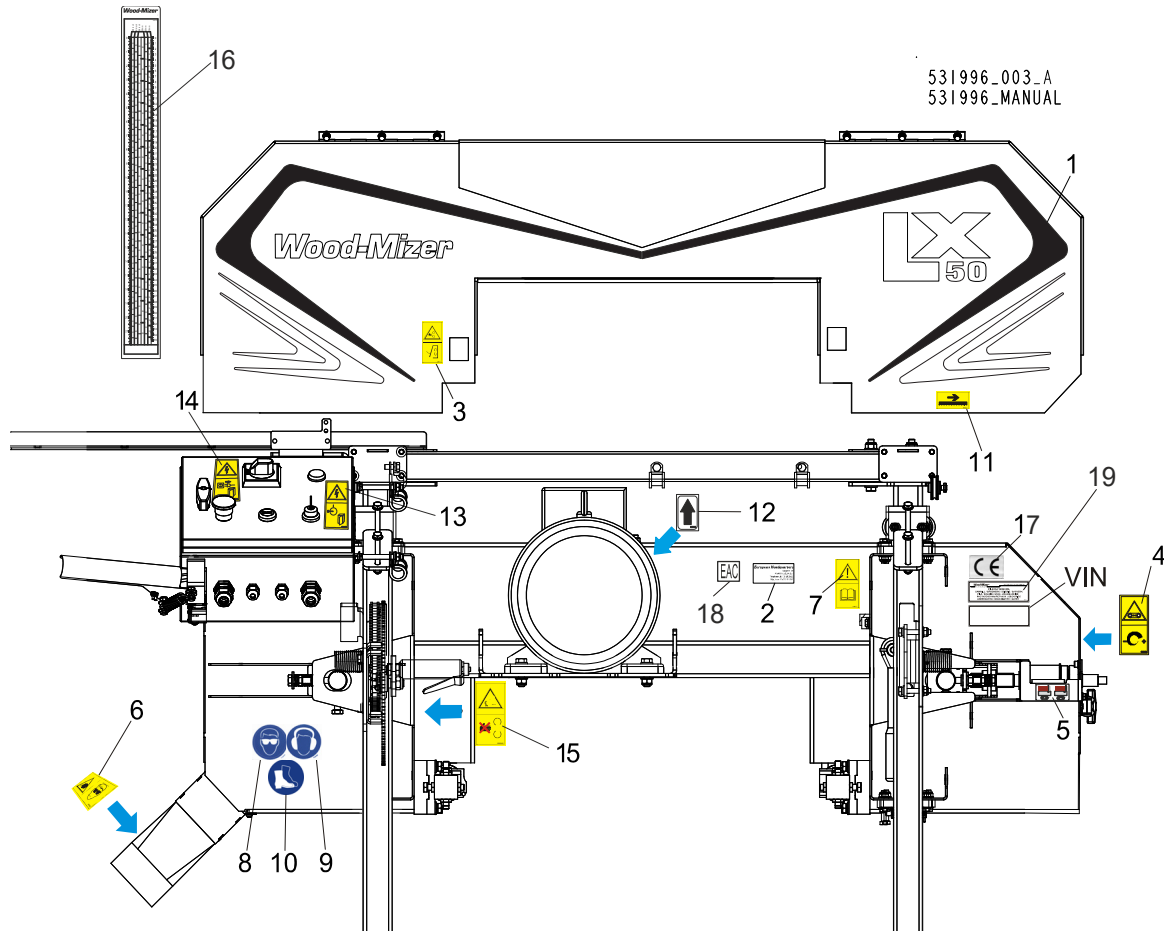

REF.	DESCRIPTION (◆ indicates parts available in assemblies only)	PART #	QTY
	PICTOGRAPHIC DECAL KIT LX50	533690	1
1	DECAL, SERIES SAWMILL	518620	1
2	DECAL, EUROPEAN HEADQUARTERS ADDRESS	015841	1
3	DECAL, SAWMILL COVERS CAUTION	099220	1
4	DECAL, BLADE TENSION (PICTOGRAM)	099219	1
5	DECAL, BLADE ALIGNMENT	527864	1
6	DECAL, SAWDUST PROTECTION, PICTOGRAM	099222	1
7	DECAL, READ OPERATOR'S MANUAL (PICTOGRAM)	096317	1
8	DECAL, EYE WARNING (PICTOGRAM)	S12004G	1
9	DECAL, EAR WARNING (PICTOGRAM)	S12005G	1
10	DECAL, USE SAFETY BOOTS (PICTOGRAM)	501465	1
11	DECAL, BLADE MOVEMENT DIRECTION (PICTOGRAM)	096321	1
12	DECAL, MOTOR DIRECTION	S20097	1
13	DECAL, HIGH VOLTAGE IN ELECTRIC BOX	096316	1
14	DECAL, DISCONNECT POWER SUPPLY BEFORE OPENING	096319	1
15	DECAL, GEAR DANGER (PICTOGRAM)	099540	1
16	DECAL, SCALE (MILLIMETRES/INCHES) LX50	535115	1
17	DECAL, CE CERTIFIED MACHINE [SMALL]	P85070	1
18	DECAL, RUSSIAN SAFETY CERTIFICATION	EAC	1
19	DECAL, INTERNATIONAL SAWMILL NAME	501466	1

3.3 Blade Height Scale (No. 530667)

530667_001_A
530667_MANUAL

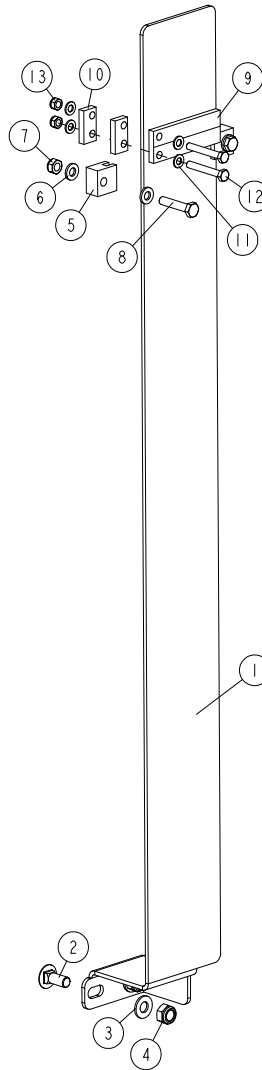

REF.	DESCRIPTION (* indicates parts available in assemblies only)	PART #	QTY
-	SCALE, BLADE HEIGHT - COMPLETE	530667	1
1	PLATE, BLADE HEIGHT SCALE ZINC-PLATED	531993-1	1
2	BOLT, M8X20-8.8 CARRIAGE ZINC	F81002-11	2
3	WASHER, 8.4 FLAT ZINC	F81054-1	2
4	NUT, M8-8-B HEX NYLON ZINC LOCK	F81032-2	2
5	BLOCK, SCALE STIFFENER	X100-1179	2
6	WASHER, 6.4 FLAT ZINC	F81053-1	4
7	NUT, M6-8-B HEX NYLON ZINC LOCK	F81031-2	2
8	BOLT, M6X30-8.8 HEX HEAD FULL THREAD ZINC	F81001-8	2
9	INDICATOR, BLADE HEIGHT SCALE	094821	1
10	SPACER, BLADE HEIGHT SCALE	550707-1	2
11	WASHER, 5.3 FLAT ZINC	F81052-1	4
12	BOLT, M5X35 8.8 HEX HEAD FULL THREAD ZINC	F81000-10	2
13	NUT, M5-8 DIN985 HEX NYLON ZINC LOCK	F81030-2	2

3.4 Up/Down Mast Guide Bracket (No. 532393)

532393_001
532393_MANUAL

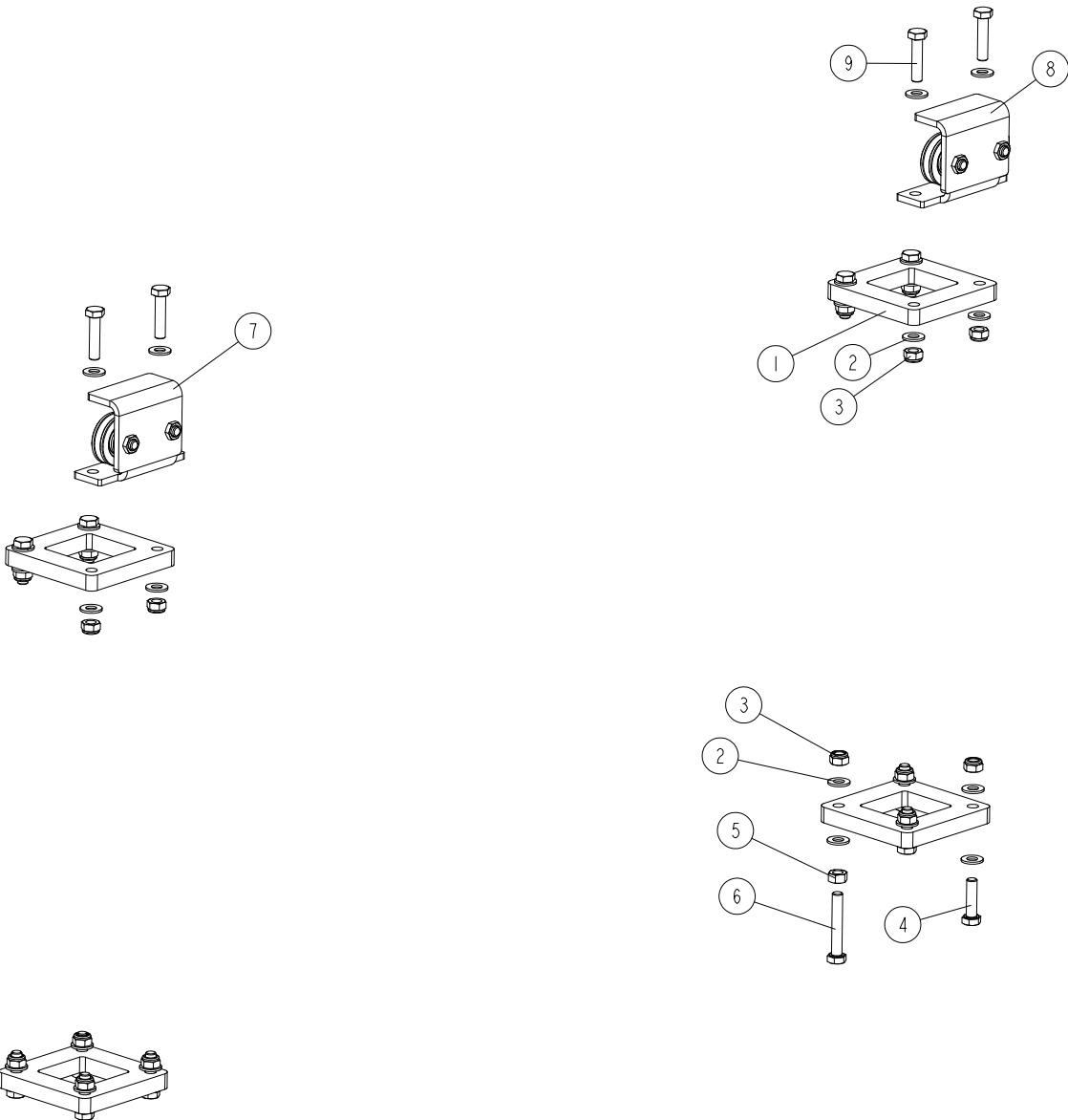

REF.	DESCRIPTION (* indicates parts available in assemblies only)	PART NO.	QTY
-	BRACKET ASSEMBLY, UP/DOWN MAST GUIDE	532393	1
1	BLOCK, VERTICAL SLIDE GUIDE	X100-327	4
2	WASHER, 8.4 FLAT ZINC	F81054-1	32
3	NUT, M8-8-B HEX NYLON ZINC LOCK	F81032-2	16
4	BOLT, M8X30 8.8 HEX HEAD FULL TREAD ZINC	F81002-7	10
5	NUT, M8-8-B HEX ZINC	F81032-1	2
6	BOLT, M8 X 65 8.8 FE/ZN5, PN-85/M-82105	F81002-9	2
7	ROLLER SET, LX50 L SAW HEAD See Section 3.5	532307	1
8	ROLLER SET, LX50 P SAW HEAD See Section 3.5	532308	1
9	BOLT, M8X35-8.8 HEX HEAD FULL THREAD ZINC	F81002-13	4

3.5 Saw Head Rollers (532307, 532308)

532307_001
532307_MANUAL

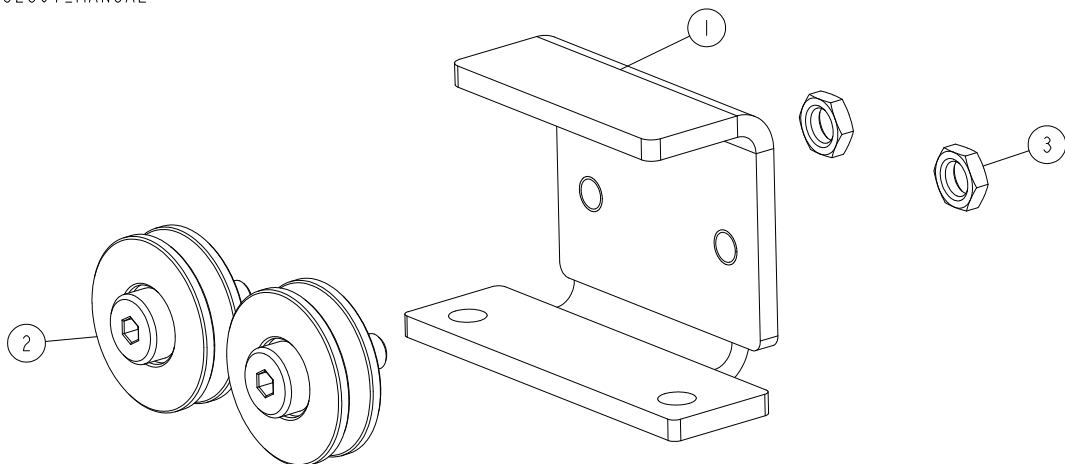

REF.	DESCRIPTION (* indicates parts available in assemblies only)	PART NO.	QTY	
-	ROLLER SET, SAW HEAD- LEFT	532307	1	
-	ROLLER SET, SAW HEAD - RIGHT	532308	1	
1	BRACKET, LX50L ROLLER MOUNT	531985-1	1	
	BRACKET, LX50 P ROLLER MOUNT	532310-1	1	
2	ROLLER, CABLE GUIDE See Section 3.6	532306	2	
3	NUT, M8-04 ISO4035 HEX THIN ZINC	F81032-8	2	

3.6 Cable Guide Roller (Part No. 532306)

532306_001_A
532306_MANUAL

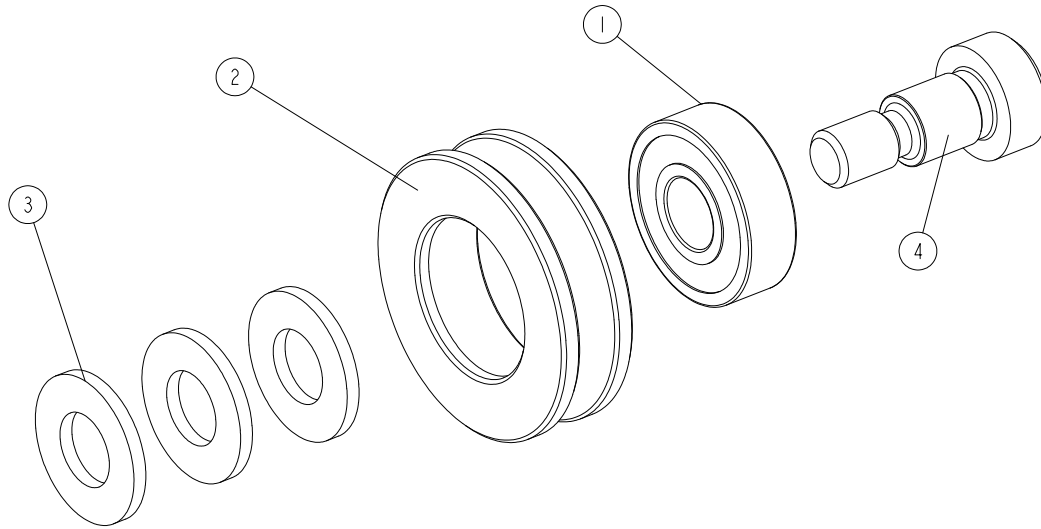

REF.	DESCRIPTION (* indicates parts available in assemblies only)	PART NO.	QTY
-	ROLLER, CABLE GUIDE	532306	1
1	BEARING, 6000.2RSR	087471	1
2	ROLLER	532000	1
3	WASHER, 10.5 FLAT ZINC	F81055-1	3
4	BOLT, 10/M8X12-12.9 BOSSARD SHOULDER	F81003-62	1

3.7 Band Wheel Assembly

X100-961_011
X100-961_MANUAL

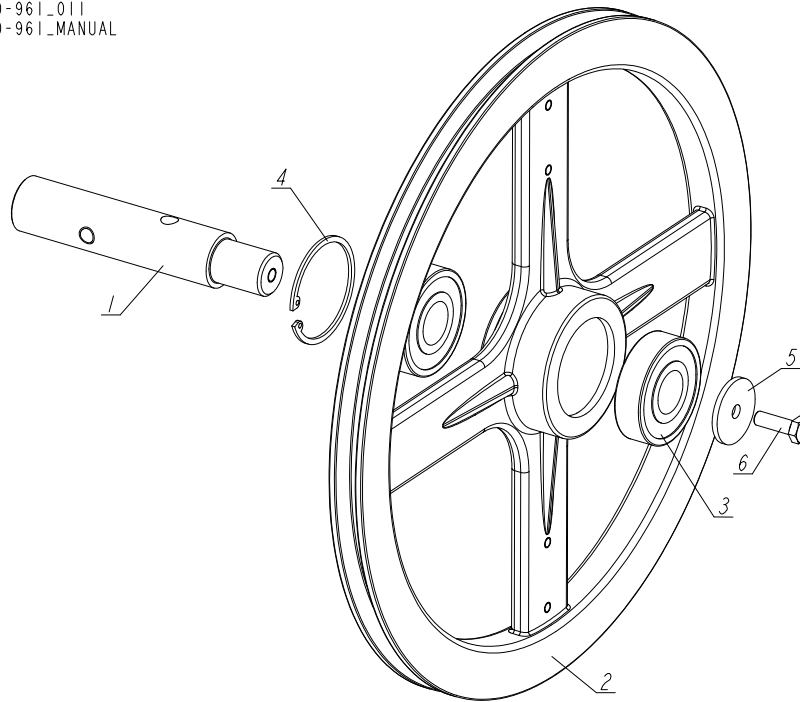

REF.	DESCRIPTION (* indicates parts available in assemblies only)	PART #	QTY
-	Assy, Bandwheel Shaft	X100-961	1
1	SPINDLE, BLADE WHEEL	X100-301	1
2	SHEAVE, BANDWHEEL, 15 3/8 OD	X100-303	1
3	BEARING, 6305 2RS NSK.	P08066	2
4	SNAP RING, 2 7/16 IR BEVELED	F04254-21	1
5	WASHER, .313X1.5X.125	S08220	1
6	BOLT, M8X25-8.8-B HEX HEAD FULL THREAD ZINC	F81002-5	1

3.8 Blade Guide Assembly, Drive Side (No, 593254)

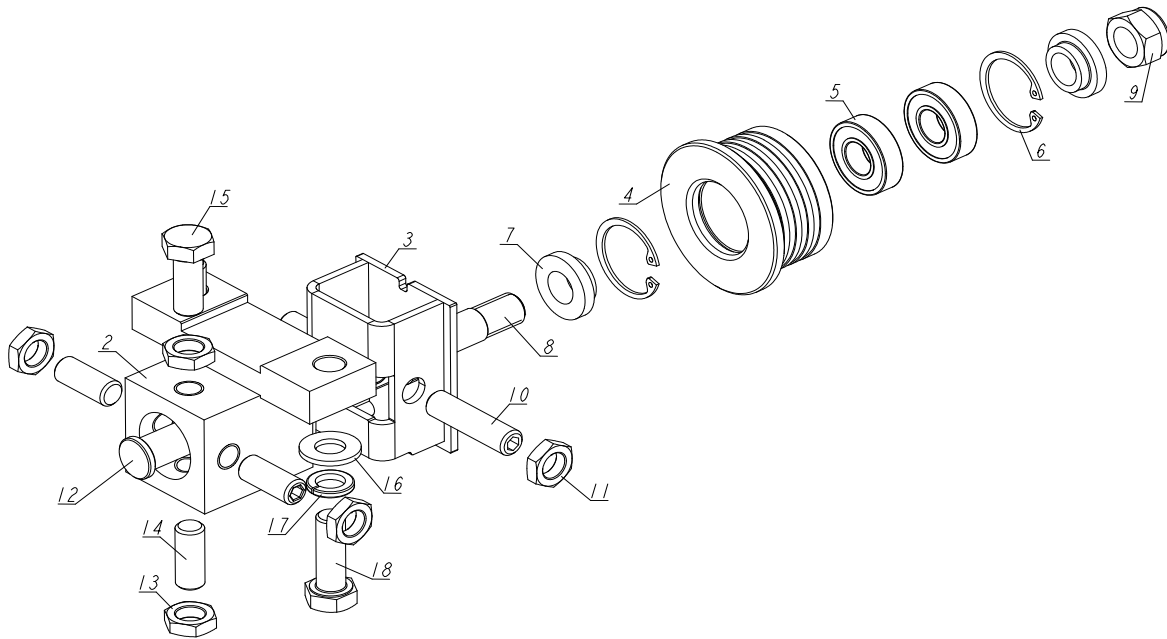
593254_001
593254

REF	DESCRIPTION (u indicates parts available in assemblies only)	PART #	QTY
-	BLADE GUIDE ASSEMBLY, DRIVE SIDE	593254	1
1	BLOCK WELDMENT, BLADE GUIDE MOUNT	087744-1	1
-	BLADE GUIDE ASSEMBLY, DRIVE SIDE	593253	1
2	BRACKET WELDMENT, BLADE GUIDE ROLLER ZINC-PLATED	593251-1	1
-	ROLLER, BLADE GUIDE W/BEARINGS	593250	1
-	ROLLER ASSY, BLADE GUIDE - PL	A09678-1	1
3	ROLLER, BLADE GUIDE NARROW	586175	1
4	BEARING, ABEG R8-2RS (12,7X28,575X7,9)	586174	2
5	RING, W29 WG PN/M-85111 INSIDE RETAINING	F81090-90	2
6	BUSHING, 12.7/25-8.2	593249-1	2
7	AXLE, LX50 BLADE GUIDE ROLLER	593248-1	1
8	NUT, M12 8 HEX NYLON ZINC LOCK	F81034-2	1
9	SCREW, M10X1X40 DIN 913 A2-70 STAINLESS	F81015-2	2
10	NUT, M10X1-04-ST-A2 ISO 8675 THIN	F81033-10	2
11	SHAFT, BLADE GUIDE MOUNT ZINC-PLATED	503588-1	1
12	NUT, M10X1-04-ST-A2 ISO 8675 THIN	F81033-10	4
13	SCREW, M10X1X25 DIN 913 STAINLESS STEEL	F81015-4	3
14	BOLT, M10X1X25 DIN 933 STAINLESS STEEL	F81003-28	1
15	WASHER, 10.5 FLAT ZINC	F81055-1	2
16	WASHER, Z 10.2 SPLIT LOCK ZINC	F81055-2	2
17	BOLT, DIN933-M10X30-8.8-A2E HEX HEAD	F81003-111	2

3.9 Blade Guide Assembly, Idle Side (No. 593258)

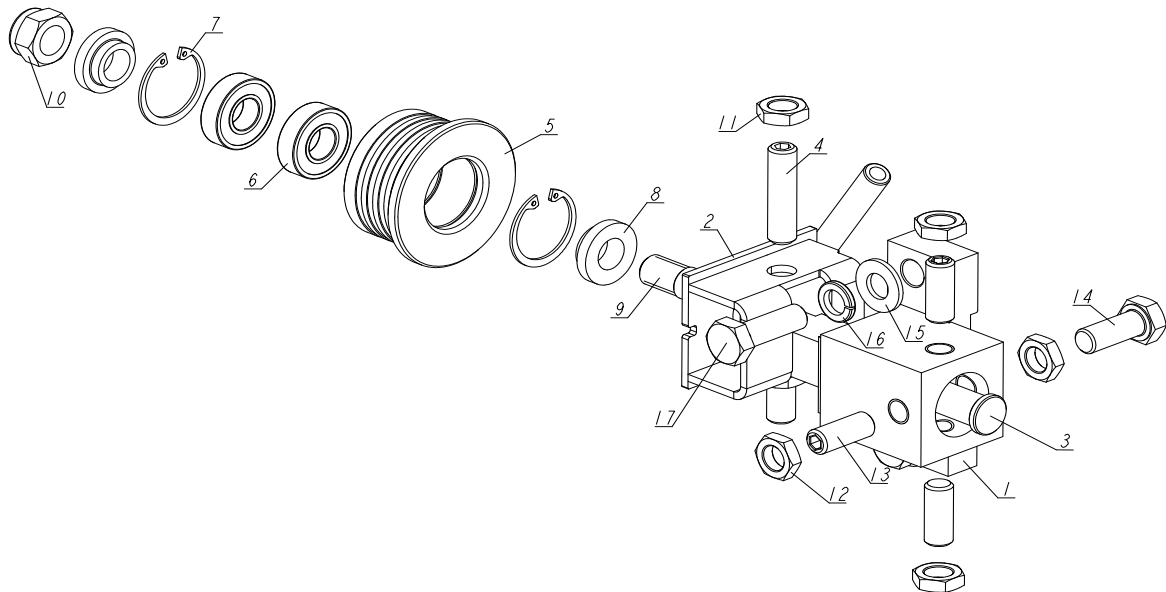
593258_001
593258

REF	DESCRIPTION (u indicates parts available in assemblies only)	PART #	QTY
-	BLADE GUIDE ASSEMBLY, IDLESIDE	593258	1
1	BLOCK WELDMENT, BLADE GUIDE MOUNT	087744-1	1
-	BLADE GUIDE ASSEMBLY, IDLE SIDE	593257	1
2	BRACKET WELDMENT, BLADE GUIDE ROLLER ZINC-PLATED	593255-1	1
3	SHAFT, BLADE GUIDE MOUNT ZINC-PLATED	503588-1	1
4	SCREW, M10X1X40 DIN 913 A2-70 STAINLESS	F81015-2	2
-	ROLLER, BLADE GUIDE W/BEARINGS	593250	1
-	ROLLER ASSY, BLADE GUIDE - PL	A09678-1	1
5	ROLLER, BLADE GUIDE NARROW	586175	1
6	BEARING, ABEG R8-2RS (12,7X28,575X7,9)	586174	2
7	RING, W29 WG PN/M-85111 INSIDE RETAINING.	F81090-90	2
8	BUSHING, 12.7/25-8.2	593249-1	2
9	AXLE, LX50 BLADE GUIDE ROLLER	593248-1	1
10	NUT, M12 8 HEX NYLON ZINC LOCK	F81034-2	1
11	NUT, M10X1-04-ST-A2 ISO 8675 THIN	F81033-10	2
12	NUT, M10X1-04-ST-A2 ISO 8675 THIN	F81033-10	4
13	SCREW, M10X1X25 DIN 913 STAINLESS STEEL	F81015-4	3
14	BOLT, M10X1X25 DIN 933 STAINLESS STEEL	F81003-28	1
15	WASHER, 10.5 FLAT ZINC	F81055-1	2
16	WASHER, Z 10.2 SPLIT LOCK ZINC	F81055-2	2
17	BOLT, DIN933-M10X30-8.8-A2E HEX HEAD	F81003-111	2

3.10 Tensioner Assembly (595710)

595710_001_B
595710

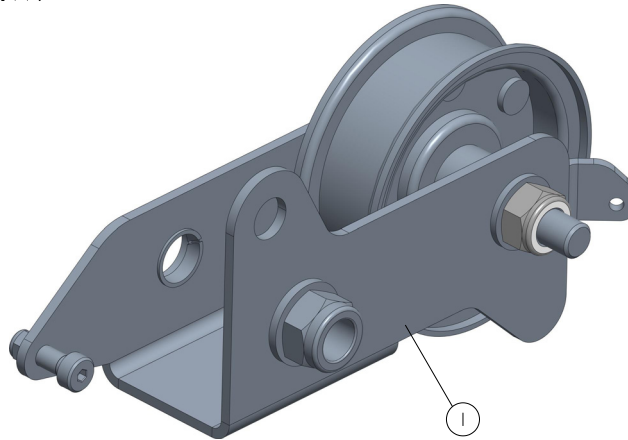

REF	DESCRIPTION (u indicates parts available in assemblies only)	PART #	QTY	
1	TENSIONER, LX50SA ASSY.	595710	1	

SECTION 4 SAWMILL MAST

4.1 LX50 Sawmill Mast

594379_001
594379

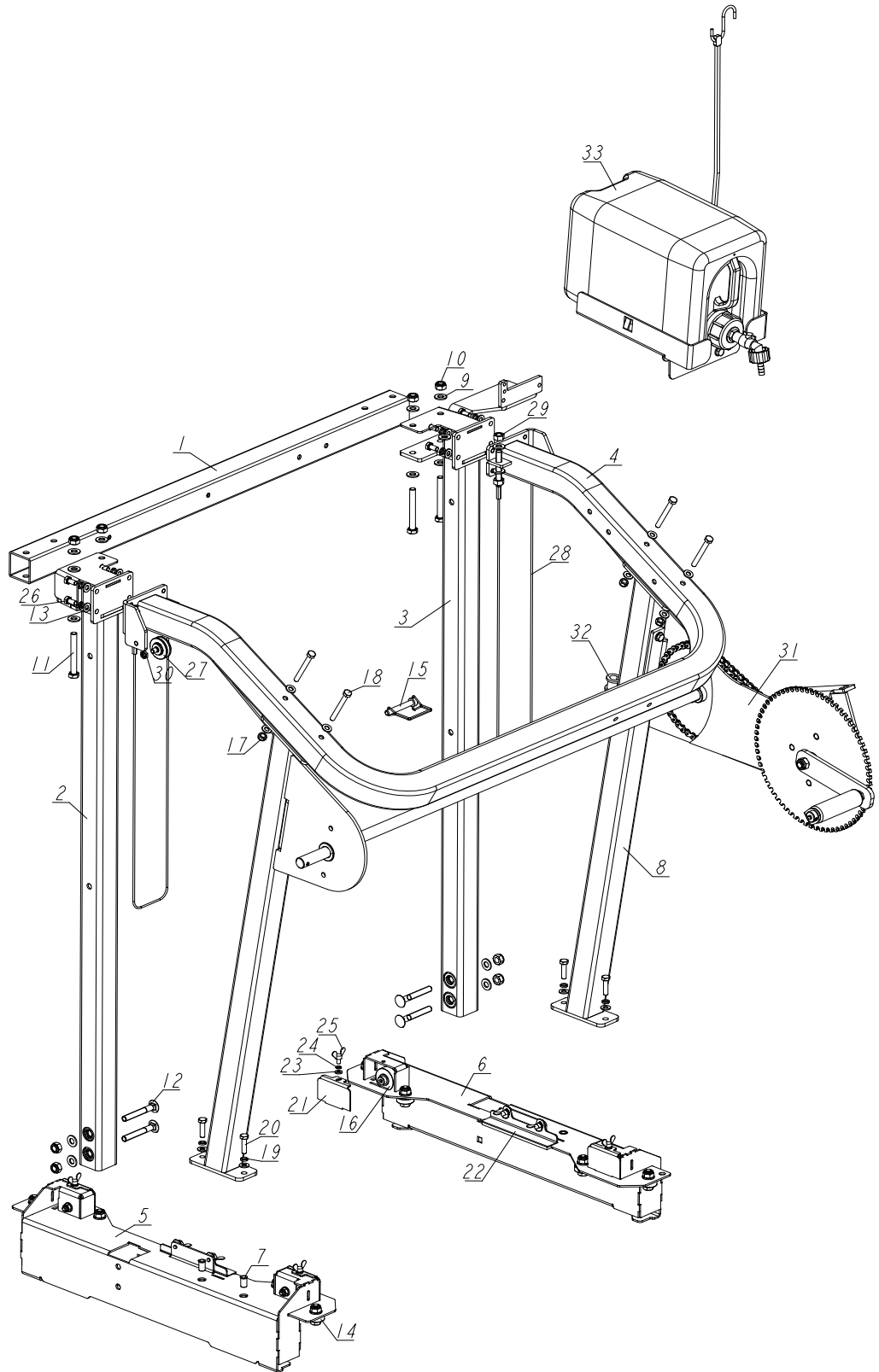

REF	DESCRIPTION (u indicates parts available in assemblies only)	PART #	QTY	
-	MAST, LX50 SAWMILL	594379	1	
1	TUBE 50X3X958	532400-1	1	
2	WLDMNT, FRONT LEFT TUBE - PAINTED.	595712-1	1	
3	WLDMNT, FRONT RIGHT TUBE - PAINTED.	594397-1	1	
4	WLDMNT, BACK TUBE	532394-1	1	
5	WELDMENT, LOWER CARRIAGE MEMBER - LEFT	X100-1123	1	
6	WELDMENT, LOWER CARRIAGE MEMBER - RIGHT	X100-1129	1	
7	NUT, M8 2.0-4.5 RIVET	F81032-10	4	
8	ASSY, RETAINING TUBE	X100-1132	2	
9	WASHER, 10.5 FLAT ZINC	F81055-1	18	
10	NUT, M10-8-B HEX NYLON ZINC LOCK	F81033-1	8	
11	BOLT, M10 X 80 -8.8- FE/ZN5 HEX HEAD	F81003-50	4	
12	BOLT, M10X75-8.8 CARRIAGE ZINC	F81003-107	4	
13	WASHER, 8.4 FLAT ZINC	F81054-1	20	
14	BEARING ASSEMBLY, HORIZONTAL See Section 4.2	X100-1135	8	
15	PIN, 3/8X2 1/4 SNAP	014151	1	
16	ASSY, CARRIAGE WHEEL See Section 4.3	X100-1136	4	
17	NUT, M8-8-B HEX NYLON ZINC LOCK	F81032-2	4	
18	BOLT, M8X70-8.8 HEX HEAD ZINC	F81002-71	4	
19	WASHER 8,2 SPLIT LOCK ZINC	F81054-4	12	
20	BOLT, M8 X 30-8.8-B HEX HEAD FULL THREAD	F81002-7	4	
21	BENT PLATE	X100-1139	4	
22	SWEEPER ASSEMBLY See Section 4.4	X100-1260	2	
23	WASHER, 6.4 FLAT ZINC	F81053-1	4	
24	WASHER, Z 6.1 SPLIT LOCK	F81053-3	4	
25	SCREW, M6X10 DIN-316/BN-276 ZINC-PL. WIN	F81001-49	4	
26	BOLT, M8X16 -8.8-B HEX HEAD FULL THREAD	F81002-20	8	
27	ROLLER, CABLE GUIDE	532306	2	
28	CABLE, STEEL DIA. -3MM L-1830MM M10	532326	2	
29	NUT, M10-8-B-HEX ZINC	F81033-3	4	
30	NUT, M8-04-FE/ZN ISO4035 HEX THIN	F81032-8	2	
31	UP/DOWN SYSTEM ASSEMBLY See Section 4.8	593261	1	
32	CLIP, RSGU 1.15/20 PIPE RETAINING	509701	1	
33	BOTTLE ASSEMBLY, 10 L WATER See Section 4.11	517062	1	

4.2 Horizontal Bearing Assembly

X100-1135_001
X100-1135_MANUAL

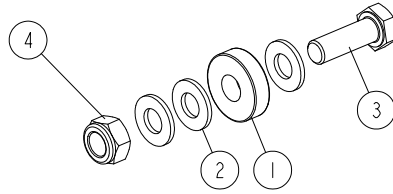

REF.	DESCRIPTION (* indicates parts available in assemblies only)	PART #	QTY	
-	ASSY, HORIZONTAL BEARING	X100-1135	1	
1	BEARING, LLU 6200	X200-903	1	
2	WASHER, 10.5 FLAT ZINC	F81055-1	3	
3	BOLT, M10X30-8.8 HEX HEAD FULL THREAD ZINC	F81003-2	1	
4	NUT, M10-8-B HEX NYLON ZINC LOCK	F81033-1	1	

4.3 Carriage Wheel Assembly

X100-1136_001
 X100-1136_MANUAL

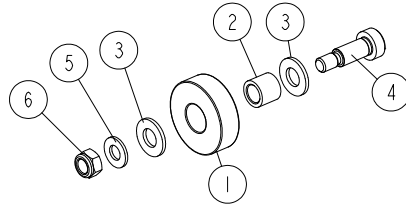

REF.	DESCRIPTION (* indicates parts available in assemblies only)	PART #	QTY	
-	ASSY, CARRIAGE WHEEL	X100-1136	1	
1	BEARING, LLU 6302	X200-957	1	
2	BUSHING 10/15-13	X100-1138	1	
3	WASHER, 10.5 FLAT ZINC	F81055-1	2	
4	BOLT, 10/M8X20-12.9 BOSSARD SHOULDER	F81003-99	1	
5	WASHER, 8.4 FLAT ZINC	F81054-1	1	
6	NUT, M8-8-B HEX NYLON ZINC LOCK	F81032-2	1	

4.4 Sweeper Assembly

X100-1260_001
X100-1260_MANUAL

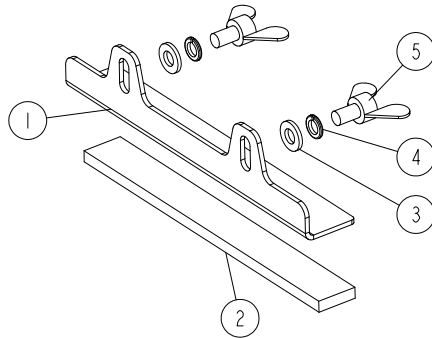

REF.	DESCRIPTION (* indicates parts available in assemblies only)	PART #	QTY	
-	ASSY, SWEEPER	X100-1260	1	
1	BENT PLATE	X100-1261	1	
2	FELT; 5 MM THK TECHNICAL	X100-1262	1	
3	WASHER, 6.4 FLAT ZINC	F81053-1	2	
4	WASHER, Z 6.1 SPLIT LOCK ZINC	F81053-3	2	
5	SCREW, M6X10 DIN-316/BN-276 ZINC-PL. WING	F81001-49	2	

4.5 Additional Equipment - Left

550419-S_001
550419-S_MANUAL

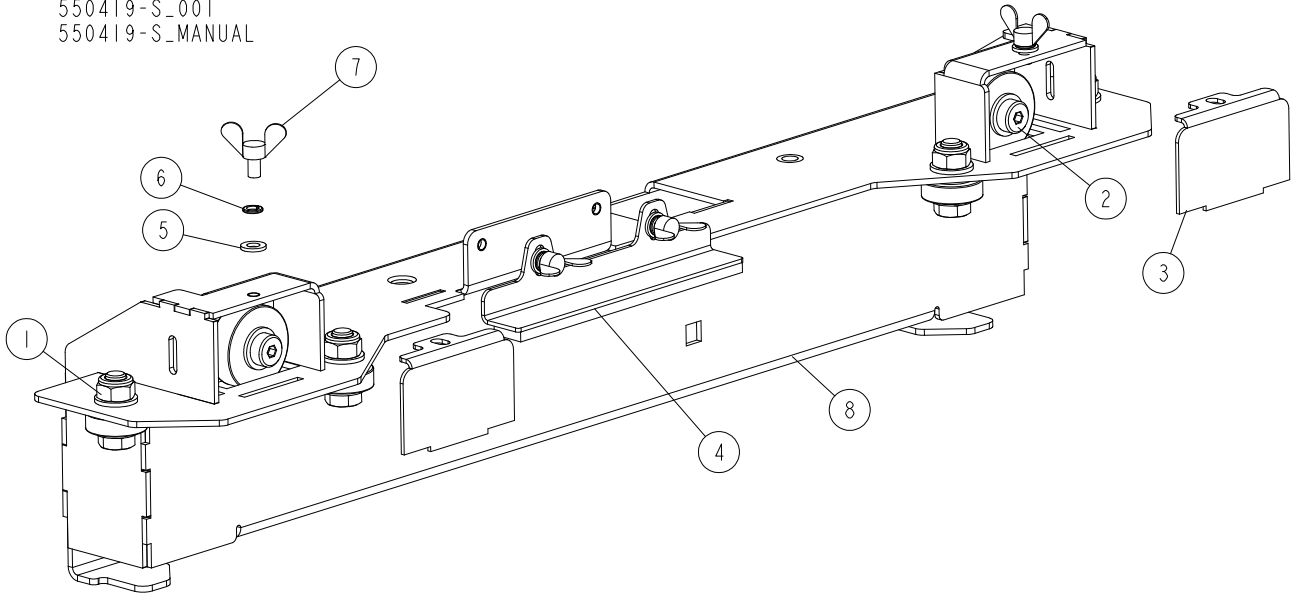

REF.	DESCRIPTION (* indicates parts available in assemblies only)	PART #	QTY
-	EQUIPMENT, LX50 LEFT ADDITIONAL	550419-S	1
1	ASSY, HORIZONTAL BEARING	X100-1135	4
2	ASSY, CARRIAGE WHEEL	X100-1136	2
3	BENT PLAT	X100-1139	2
4	ASSY, SWEEPER	X100-1260	1
5	WASHER, 6.4 FLAT ZINC	F81053-1	2
6	WASHER, Z 6.1 SPLIT LOCK ZINC	F81053-3	2
7	SCREW, M6X10 FE/ZN5 DIN-316/BN-276 WING	F81001-49	2
8	WLDMNT, LOWER CARRIAGE MEMBER - LEFT	X100-1123	1

4.6 Additional Equipment - Right

550512-S_001
550512-S_MANUAL

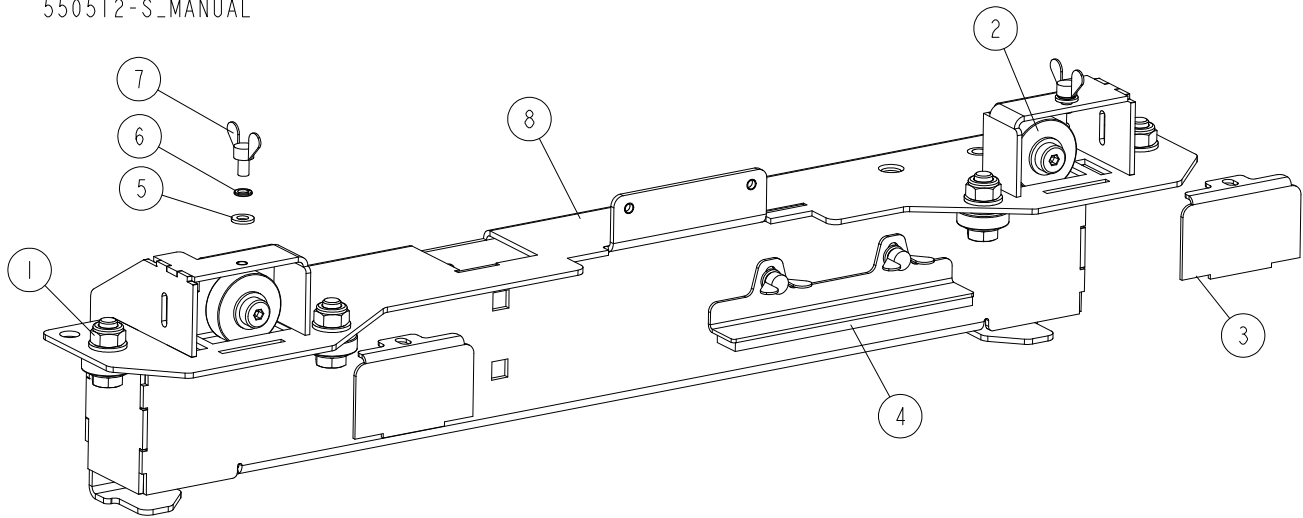

REF.	DESCRIPTION (* indicates parts available in assemblies only)	PART #	QTY	
-	EQUIPMENT, LX50 ADDITIONAL RIGHT	550512-S	1	
1	ASSY, HORIZONTAL BEARING	X100-1135	4	
2	ASSY, CARRIAGE WHEEL	X100-1136	2	
3	BENT PLAT	X100-1139	2	
4	ASSY, SWEEPER	X100-1260	1	
5	WASHER, 6.4 FLAT ZINC	F81053-1	2	
6	WASHER, Z 6.1 SPLIT LOCK ZINC	F81053-3	2	
7	SCREW, M6X10 FE/ZN5 DIN-316/BN-276 WING	F81001-49	2	
8	WLDMNT, LOWER CARRIAGE MEMBER - RIGHT	X100-1129	1	

4.7 Blade Tensioner Assembly

X100-1246_001
X100-1246_MANUAL

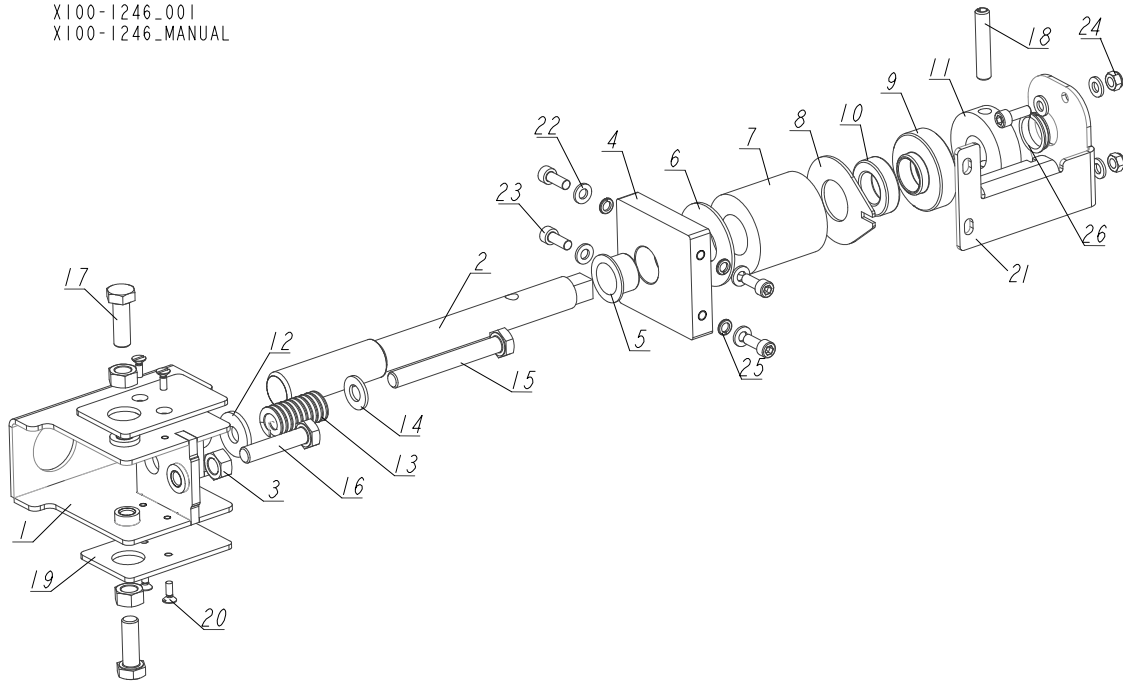

REF.	DESCRIPTION (* indicates parts available in assemblies only)	PART NO.	QTY
-	ASSY, TENSIONER	X100-1246	1
1	WLDMT, TENSIONER	X100-1239	1
2	TENSIONER ROD	X100-1252	1
3	NUT, M10 8 HEX ZINC	F81033-3	3
4	TENSIONER BLOCK	X100-1247	1
5	BUSHING IGUS GFM-2023-16	X100-1256	1
6	WASHER 52X21-2	X100-1284	1
7	SPRING, TENSIONER BLADE LT15	014828	1
8	FLAT PLATE	X100-1251	1
9	BEARING BUSHING	X100-1248	1
10	BEARING, 51104 CX BALL THRUST	511979	1
11	BUSHING 16.1/50-15	X100-1250	1
12	WASHER, 10.5 SPECIAL FLAT ZINC	F81055-6	1
13	SPRING, 3/4 O.D.X 1 1/2 DIE	034430	1
14	WASHER, 10.5 FLAT ZINC	F81055-1	1
15	BOLT, M10X80-8.8 HEX HEAD ZINC	F81003-50	1
16	BOLT, M10X45 HEX HEAD FULL THREAD ZINC	F81003-3	1
17	BOLT, M10X30-8.8 HEX HEAD FULL THREAD ZINC	F81003-2	2
18	PIN, 8X45 ROLL ZINC	F81046-6	1
19	POLYETHYLENE PLATE	X100-1249	2
20	SCREW, M4X12 5.8-B SLOTTED COUNTERSUNK HEAD ZINC	F81011-41	4
21	BENT PLATE	X100-1253	1
22	WASHER, 6.4 FLAT ZINC	F81053-1	8
23	SCREW, M6X16 8.8 HEX SOCKET HEAD CAP ZINC	F81001-21	6
24	NUT, M6-8-B HEX NYLON ZINC LOCK	F81031-2	2
25	WASHER, Z 6.1 SPLIT LOCK ZINC	F81053-3	4
26	CLIP BEARING MCM-20-03	X100-1259	1

4.8 Up/Down System

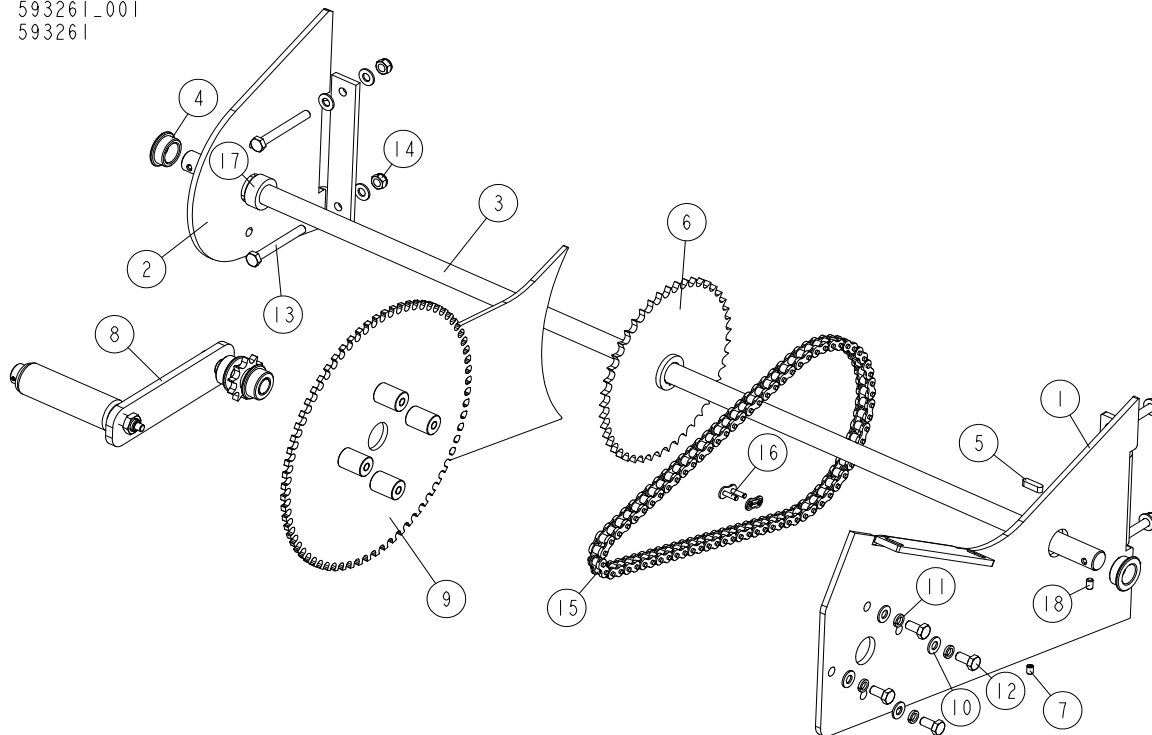
593261_001
593261

REF	DESCRIPTION (u indicates parts available in assemblies only)	PART #	QTY
-	UP/DOWN SYSTEM	593261	1
1	SUPPORT PLATE, WINCH AXIS	594382-1	1
2	PLATE, SUPPORT	594384-1	1
3	SHAFT, SHAFT, WINCH LX50/M120	593259-1	1
4	BUSHING, LX50, BUSHING, SLIDE	532332	2
5	KEY, A 6X6X22 PARALLEL	519161	1
6	SPROCKET ASSEMBLY, LARGE	532323-1	1
7	SCREW, M6X8 HEX SOCKET SET CONE POINT ZI	F81013-1	1
8	CRANK, WINCH	532318	1
9	SCALE	594381-1	1
10	WASHER, 8.4 FLAT ZINC	F81054-1	12
11	WASHER 8,2 SPLIT LOCK ZINC	F81054-4	4
12	BOLT, M8X16 -8.8-B HEX HEAD FULL THREAD	F81002-20	4
13	BOLT, M8X70-8.8 HEX HEAD ZINC	F81002-71	4
14	NUT, M8-8-B HEX NYLON ZINC LOCK	F81032-2	4
15	CHAIN, 08B-1 L=939 73 (73 LINKS), CHAIN, 08B L-939 73-LINK	532365	1
16	LINK, 08B-1PZ MASTER	091625	1
17	RING, 20 RETAINING	593260	1
18	SCREW, M6X10-45H HEX SOCKET SET W/FLAT P	F81001-26	2

4.9 Winch Crank (No. 532318)

532318_001
532318_MANUAL

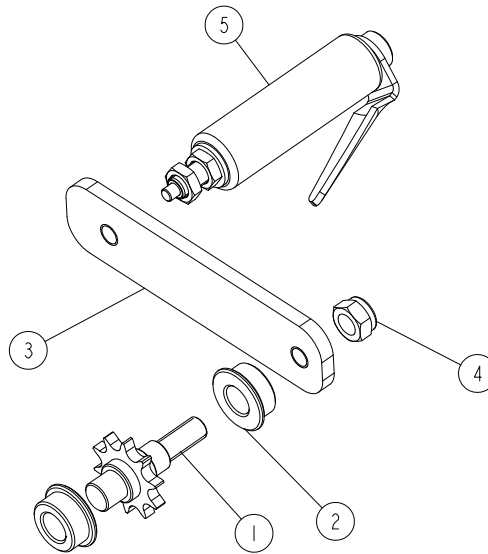

REF.	DESCRIPTION (* indicates parts available in assemblies only)	PART #	QTY	
-	CRANK, WINCH	532318	1	
1	SPROCKET ASSEMBLY, SMALL	532319-1	1	
2	BUSHING, SLIDE	532333	2	
3	PLATE, CRANK	531997-1	1	
4	NUT, M12 8 HEX NYLON ZINC LOCK	F81034-2	1	
5	HANDLE, CRANK See Section 4.10	096499	1	

4.10 Winch Crank Handle (No. 096499)

096499_001
096499_MANUAL

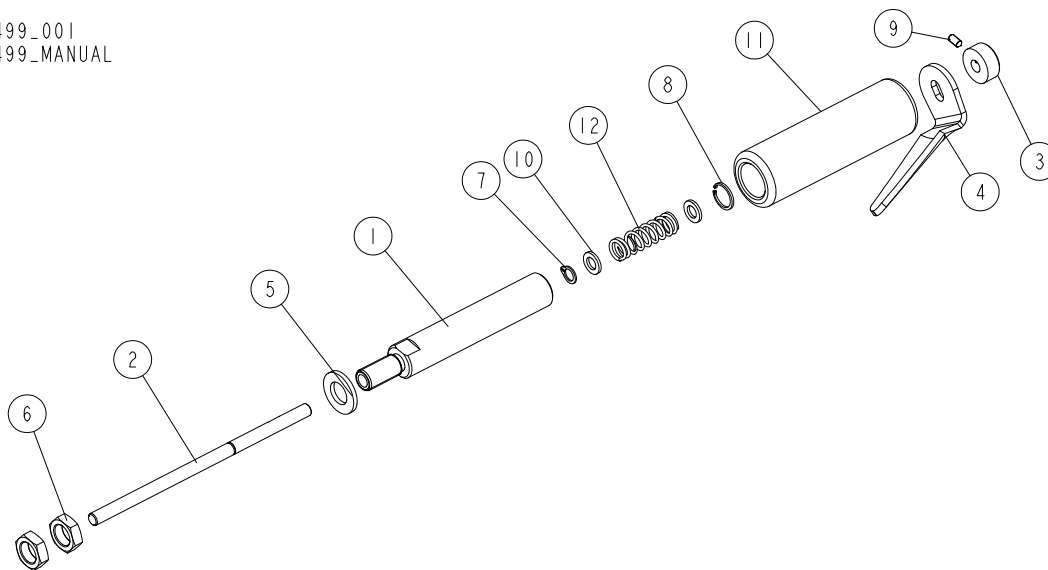

REF.	DESCRIPTION (* indicates parts available in assemblies only)	PART #	QTY
-	HANDLE, CRANK	096499	1
1	MANDREL, CRANK HANDLE	096504-1	1
2	PIN, CRANK HANDLE	097095-1	1
3	RING, 7 STOPPING LIGHT TYPE	F81039-9	1
4	PLATE, LX50	587015-1	1
5	WASHER, 13 FLAT ZINC	F81056-1	1
6	NUT, M12-04-A THIN ZINC	F81034-6	2
7	RING, Z7 OUTSIDE RETAINING	F81090-17	1
8	RING, W13 INSIDE RETAINING	F81090-18	1
9	SCREW, M4X8 GEOMET HEX SOCKET SET W/FLAT POINT	F81011-40	1
10	WASHER, 7.2/12.5	097264	2
11	TUBE, CRANK HANDLE	097263	1
12	SPRING, .48DIA X 1.5 LONG SS COMPRESSION	047690	1

4.11 Water Lube Assembly

517062_001_A
517062_MANUAL

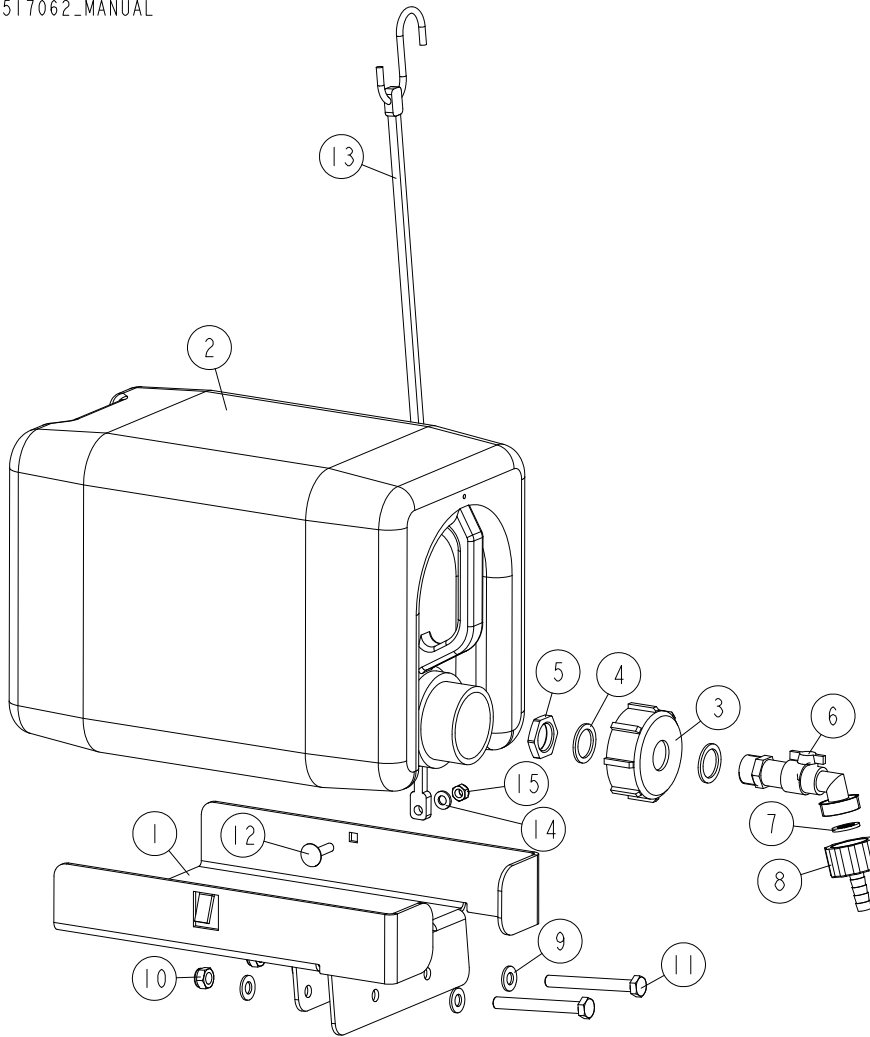

REF	DESCRIPTION (u indicates parts available in assemblies only)	PART #	QTY
-	BOTTLE ASSEMBLY, 10 L WATER	517062	1
1	TRAY, 10 L WATER BOTTLE	516436-1	1
-	TANK, OIL	550786	1
2	TANK, 10L OIL	711400	1
3	NUT, BOTTLE	550785	1
4	SEAL, 27X20X1.5 ESSENTRA 467673 RUBBER	550780	2
5	NUT, 1/2 ESSENTRA 467615 GLAND	550779	1
6	FITTING, WATER LUBE SHUTOFF VALVE	550776	1
7	FILTER, WATER LUBE	550778	1
8	FITTING, G3/4" X 10MM HOSE BARB	550777	1
9	WASHER, 8.4 FLAT ZINC	F81054-1	4
10	NUT, M8-8-B HEX NYLON ZINC LOCK	F81032-2	2
11	BOLT, M8X70-8.8 HEX HEAD ZINC	F81002-71	2
12	BOLT, M6X25-8.8 ZINC	F81001-20	1
13	STRAP, 15 RUBBER W/S HOOKS	P07461	1
14	WASHER, 6.4 FLAT ZINC	F81053-1	1
15	NUT, M6-8-B HEX NYLON ZINC LOCK	F81031-2	1

SECTION 5 MOTORS

5.1 Motor Kit

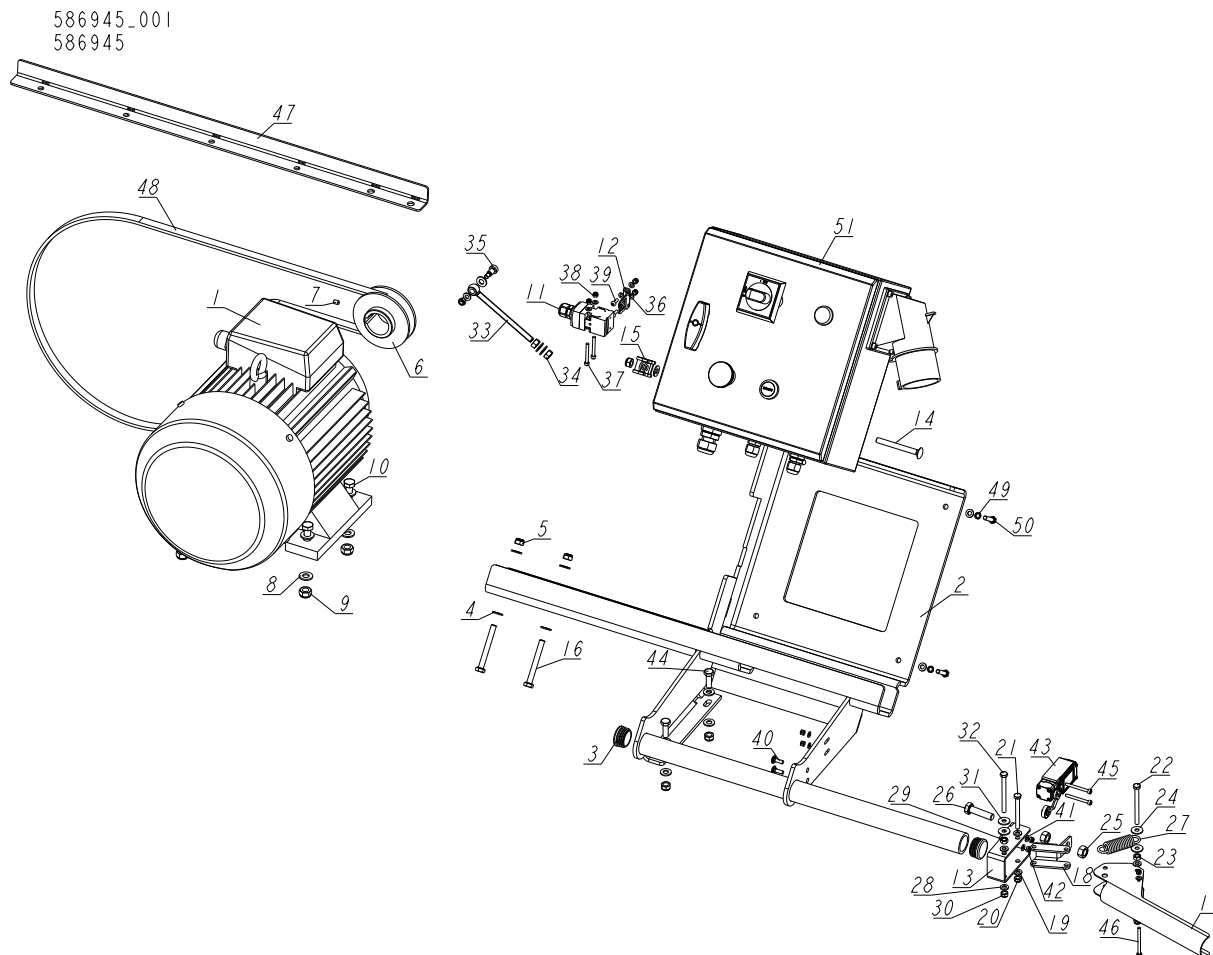

REF	DESCRIPTION (◆ indicates parts available in assemblies only)	PART #	QTY
-	MOTOR KIT, EH7S CE LX50	586945	1
-	MOTOR KIT, EB7S LX50	586945-2	1
-	MOTOR KIT, EH7 LX50	586945-3	1
-	MOTOR KIT, EC7 LX50	586945-4	1
-	MOTOR KIT, EB7 LX50	586945-5	1
1	MOTOR, 5.5KW SG 132S-2A	526139	1
2	BRACKET, ELECTRIC BOX	595725-1 ¹	1
	BRACKET, ELECTRIC BOX See Section 5.2	595735-1 ²	1
3	CAP, SR1530 (HOLE 30) TUBE	517616	2
4	WASHER, 8.4 FLAT ZINC	F81054-1	12
5	NUT, M8-8-B HEX NYLON ZINC LOCK	F81032-2	5
6	PULLEY, M100 TIMBERY	T00406-1	1
7	SCREW, M6X8 HEX SOCKET SET CONE POINT ZI	F81013-1	1
8	WASHER, 10.5 FLAT ZINC	F81055-1	8
9	NUT, M10-8-B HEX NYLON ZINC LOCK	F81033-1	4
10	BOLT, M10X40-8.8 HEX HEAD FULL THREAD ZI	F81003-16	4

REF	DESCRIPTION (◆ indicates parts available in assemblies only)	PART #	QTY
11	SWITCH, AZ17-11ZRK SAFETY 1	094232	1
12	KEY, AZ17/170-B5 SAFETY SWITCH 2	094422	1
13	BRACKET WELDMENT	532316-1	1
14	BOLT, M8X75 DIN603 ZINC MUSHROOM HEAD SQ	F81002-106	1
15	CLIP, RSGU 1.20/20 METAL & RUBBER RETAIN	F81087-2	1
16	BOLT, M8X70-8.8 HEX HEAD ZINC	F81002-71	2
17	LEVER, CABLE	532336-1	1
-	ASSY, TRIGGER PLATE	X100-1231	1
18	BRACKET	532324-1	1
19	WASHER, 6.4 FLAT ZINC	F81053-1	4
20	NUT, M6-8-B HEX NYLON ZINC LOCK	F81031-2	2
21	BOLT, M6X60-8.8 HEX HEAD FULL THREAD ZIN	F81001-9	1
22	BOLT, M6X70 8.8 HEX HEAD FULL THREAD ZIN	F81001-63	1
23	NUT, M6 8 HEX ZINC	F81031-1	1
24	WASHER, 6.5 SPECIAL FLAT ZINC	F81053-11	2
25	NUT, M10-8-B-HEX ZINC	F81033-3	2
26	BOLT, M10X40-8.8 HEX HEAD FULL THREAD ZI	F81003-16	1
27	SPRING, 3/4X2 7/8X12GA	015479	1
28	WASHER, 6.4 FLAT ZINC	F81053-1	7
29	NUT, M6 8 HEX ZINC	F81031-1	1
30	NUT, M6-8-B HEX NYLON ZINC LOCK	F81031-2	2
31	WASHER, 6.5 SPECIAL FLAT ZINC	F81053-11	2
32	BOLT, M6X70 8.8 HEX HEAD FULL THREAD ZIN	F81001-63	1
33	BOLT, M8X120 8.8 DIN444 EYE	F81002-64	1
34	NUT, M8-8-B HEX ZINC	F81032-1	2
35	BOLT, 8/M6X12-12.9 ISO 7379 SHOULDER	F81001-56	1
36	WASHER, 4.3 FLAT ZINC	F81051-2	10
37	SCREW, M4X35 8.8 HEX SOCKET HEAD CAP ZIN	F81011-34	2
38	NUT, M4-8 HEX NYLON ZINC LOCK	F81029-1	7
39	SCREW, M4X12 5,8-B CROSS RECESSED PAN HE	F81011-43	2
40	BOLT, M5X16 DIN 603 CARRIAGE	F81000-75	2
41	WASHER, 5.3 FLAT ZINC	F81052-1	2
42	NUT, M5-8 DIN985 ZINC-PLATED	F81030-2	2
43	SWITCH, FA138 Z11 LIMIT	100931	1
44	BOLT, M8X25-8.8-B HEX HEAD FULL THREAD Z	F81002-5	2
45	SCREW, M4X40-8.8 SOCKET HEAD ZINC	F81011-37	2
46	BOLT, M4X50-8.8 DIN933 HEX HEAD ZINC	F81011-48	1
47	ANGLE, 30X30 L-720	532327-1	1
48	V-BELT, BX69 17X1798 LP CONTITECH	551002	1
49	WASHER, Z 6.1 SPLIT LOCK	F81053-3	4
50	BOLT, M6X30-8.8 HEX HEAD FULL THREAD ZIN	F81001-8	4
51	BOX, M120E7 ELECTRIC	526997	1

¹ Included in assy No. 586945

² Included in assy No. 586945-3

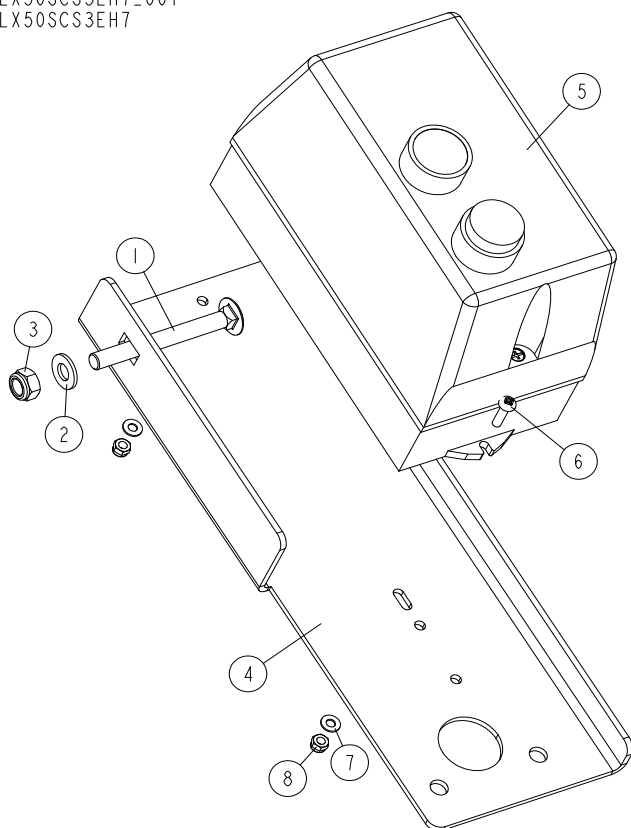
**5.2 Electric Box Bracket, Starter (included in assy No. 586945-3)**LX50SCS3EH7_001
LX50SCS3EH7

REF	DESCRIPTION (u indicates parts available in assemblies only)	PART #	QTY	
-	MOTOR KIT, EH7 LX50	586945-3	1	
1	BOLT, M8X75 DIN603 CARRIAGE ZINC	F81002-106	1	
2	WASHER, 8.4 FLAT ZINC	F81054-1	1	
3	NUT, M8-8-B HEX NYLON ZINC LOCK	F81032-2	1	
4	BLACHA MOCOWANIA PRZEŁĄCZNIKA	595735-1	1	
5	STARTER, 12A MAX (5.5 KW AT 400V) IP65	517343	1	
6	SCREW, M4X16 5.8-B CROSS RECESSED PAN HE	F81011-42	2	
7	WASHER, 4.3 FLAT ZINC	F81051-2	2	
8	NUT, M4-8 HEX NYLON ZINC LOCK	F81029-1	2	

5.3 Electric Box

526997_001
526997

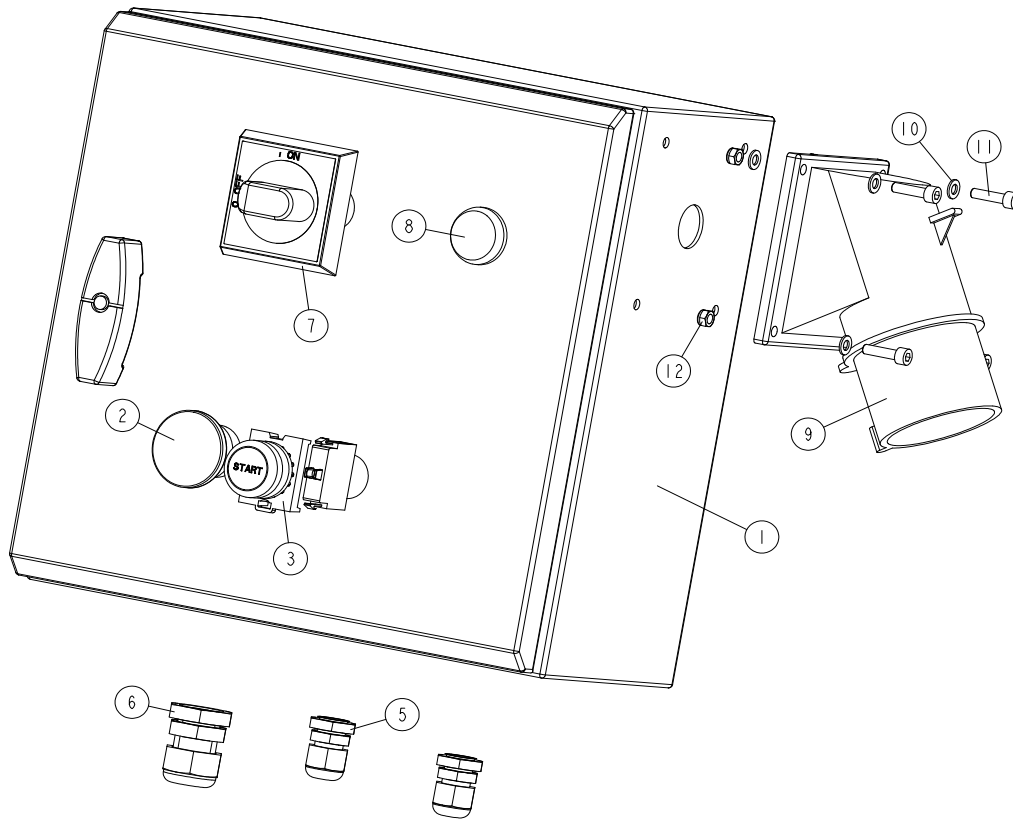

REF	DESCRIPTION (u indicates parts available in assemblies only)	PART #	QTY
-	BOX, M120E7 ELECTRIC	526997	1
1	BOX, CONTROL XC100 - 400V	526998	1
2	BUTTON, XB4 BS542 EMERGENCY STOP	086556	1
3	BUTTON, M22 FLAT GREEN	090925	1
4	CONTACT, M22 - K10	091362	1
5	GLAND, DP9/H CABLE	F81096-2	2
6	GLAND, DP16/H CABLE	F81096-7	1
7	HANDLE, ABB SWITCH	088265-1	1
8	LIGHT, M22 LED 24V BLUE CONTROL	090448	1
9	PLUG, 16A 5P 778152-6 PCE	E85239	1
10	WASHER, 5.3 FLAT ZINC	F81052-1	8
11	BOLT, M5X20-8.8 SOCKET HEAD ZINC	F81000-72	4
12	NUT, M5-8 DIN985 ZINC-PLATED	F81030-2	4

5.4 G14 Engine Kit

595720_001
595720

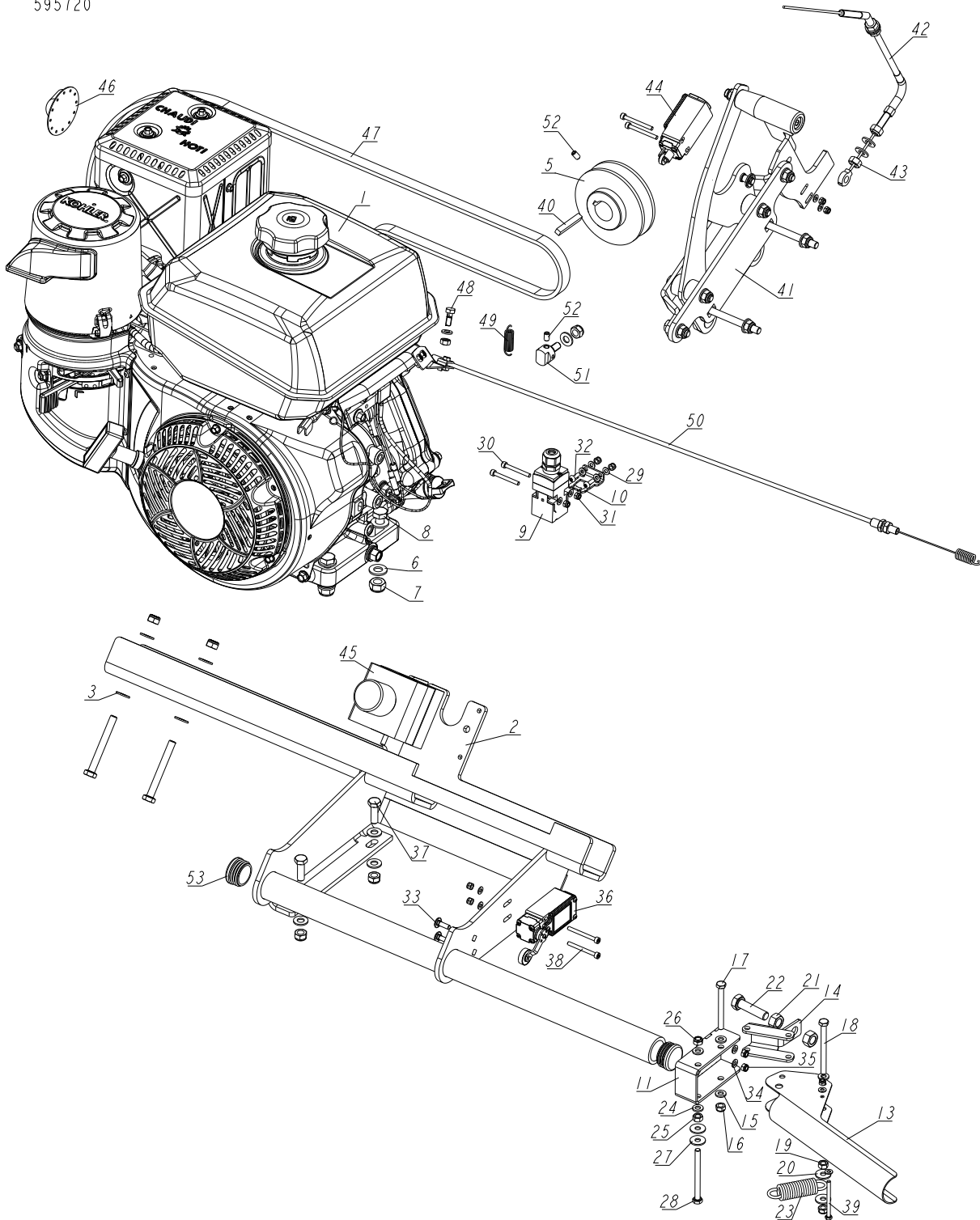

REF	DESCRIPTION (◆ indicates parts available in assemblies only)	PART #	QTY	
-	ENGINE KIT, G14S CE LX50 COMPLETE	595720	1	-
-	ENGINE KIT, G14 CE LX50 COMPLETE	595720-3	1	-
-	ENGINE KIT, G14 LX50 COMPLETE	595720-U	1	-

REF	DESCRIPTION (◆ indicates parts available in assemblies only)	PART #	QTY
1	ENGINE, KOHLER G14 (CH440-3149)	X200-1201	1
2	BRACKET, ELECTRICAL BOX	594386-1	1
3	WASHER, 8.4 FLAT ZINC	F81054-1	13
4	NUT, M8-8-B HEX NYLON ZINC LOCK	F81032-2	5
5	SHEAVE, G13/14	550887-1	1
6	WASHER, 10.5 FLAT ZINC	F81055-1	8
7	NUT, M10-8-B HEX NYLON ZINC LOCK	F81033-1	4
8	BOLT, M10X45-8.8 HEX HEAD FULL THREAD ZI	F81003-3	4
9	SWITCH, AZ17-11ZRK SAFETY 1	094232	1
10	KEY, AZ17/170-B5 SAFETY SWITCH 2	094422	1
11	BRACKET WELDMENT	532316-1	1
12	BOLT, M8X70-8.8 HEX HEAD ZINC	F81002-71	2
13	LEVER, CABLE	532336-1	1
-	ASSY, TRIGGER PLATE	595723	1
14	BRACKET	532324-1	1
15	WASHER, 6.4 FLAT ZINC	F81053-1	4
16	NUT, M6-8-B HEX NYLON ZINC LOCK	F81031-2	2
17	BOLT, M6X60-8.8 HEX HEAD FULL THREAD ZIN	F81001-9	1
18	BOLT, M6X70 8.8 HEX HEAD FULL THREAD ZIN	F81001-63	1
19	NUT, M6 8 HEX ZINC	F81031-1	1
20	WASHER, 6.5 SPECIAL FLAT ZINC	F81053-11	2
21	NUT, M10-8-B-HEX ZINC	F81033-3	2
22	BOLT, M10X40-8.8 HEX HEAD FULL THREAD ZI	F81003-16	1
23	SPRING, 3/4X2 7/8X12GA	015479	1
24	WASHER, 6.4 FLAT ZINC	F81053-1	3
25	NUT, M6 8 HEX ZINC	F81031-1	2
26	NUT, M6-8-B HEX NYLON ZINC LOCK	F81031-2	1
27	WASHER, 6.5 SPECIAL FLAT ZINC	F81053-11	2
28	BOLT, M6X70 8.8 HEX HEAD FULL THREAD ZIN	F81001-63	1
29	WASHER, 4.3 FLAT ZINC	F81051-2	14
30	SCREW, M4X35 8.8 HEX SOCKET HEAD CAP ZIN	F81011-34	2
31	NUT, M4-8 HEX NYLON ZINC LOCK	F81029-1	9
32	SCREW, M4X12 5.8-B CROSS RECESSED PAN HE	F81011-43	2
33	BOLT, M5X16 DIN 603 CARRIAGE	F81000-75	2
34	WASHER, 5.3 FLAT ZINC	F81052-1	2
35	NUT, M5-8 DIN985 ZINC-PLATED	F81030-2	2
36	SWITCH, FA138 Z11 LIMIT	100931	1
37	BOLT, M8X25-8.8-B HEX HEAD FULL THREAD Z	F81002-5	2
38	SCREW, M4X40-8.8 SOCKET HEAD ZINC	F81011-37	4
39	BOLT, M4X50-8.8 DIN933 HEX HEAD ZINC	F81011-48	1
40	KEY, 1/4 X 1 11/16	S04124	1
41	LEVER, CLUTCH	532363	1
42	CABLE, M120 TENSIONER	534518	1
43	NUT, M8-8-B HEX ZINC	F81032-1	4
44	LIMIT SWITCH GLCB01C - D25 7	100910	1
45	SWITCH, M22-PV/KCO2 EMERGENCY STOP	094726	1
46	DEFLECTOR, KOHLER14HP EXHAUST	110187	1

REF	DESCRIPTION (◆ indicates parts available in assemblies only)	PART #	QTY	
47	V-BELT, BX71 17X1848 LD (CONTITECH)	551001	1	
48	BOLT, THROTTLE CABLE CLAMP ZINC-PLATED	088120-1	1	
	THROTTLE FITTING, SWIVEL W/ 1 SCREW	048904 ¹	1	
49	SPRING, LX50 TENSIONER (GRENE NR 0050582	593262	1	
50	CABLE, LX50SC THROTTLE	550814	1	
51	ELEMENT, CLUTCH CABLE MOUNTING	551000-1	1	
52	SCREW, M6X10-45H HEX SOCKET SET W/FLAT P	F81001-26	2	
53	CAP, SR1530 (HOLE 30) TUBE	517616	2	

¹ US market only

5.5 Clutch Lever

532363_001
532363_MANUAL

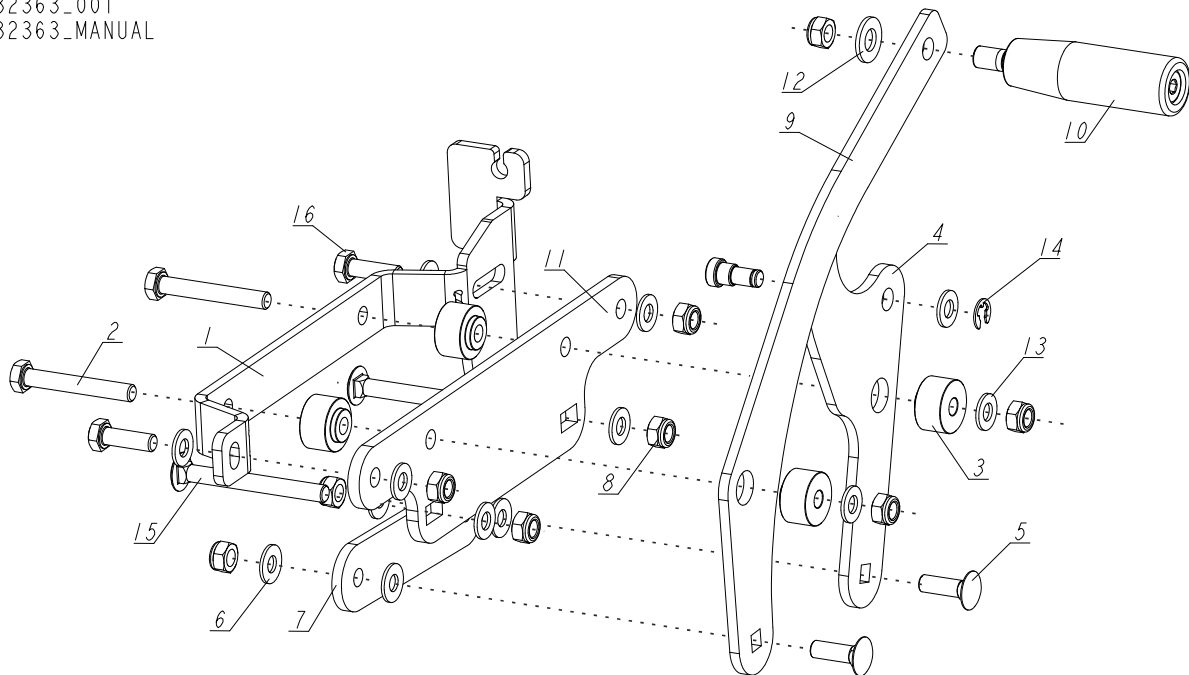

REF.	DESCRIPTION (* indicates parts available in assemblies only)	PART #	QTY
-	LEVER, CLUTCH	532363	1
1	PLATE, CLUTCH ARM MOUNTING	X100-1323	1
2	BOLT, M8X55-8.8 HEX HEAD ZINC	F81002-8	2
3	SPACER	X100-1325	4
4	CLUTCH PIVOT ARM WELDING	X100-1328	1
5	BOLT, M8X25-8.8 ZINC MUSHROOM HEAD SQUARE NECK	F81002-59	2
6	JTM-0818-015	X100-1311	4
7	PLATE, CLUTCH ENGAGEMENT ARM	X100-1310	1
8	NUT, M8-8-B HEX NYLON ZINC LOCK	F81032-2	9
9	PLATE, CLUTCH MOUNTING ARM	X100-1326	1
10	KNOB, PLASTIC CRANK HANDLE	086338	1
11	PLATE	534503-1	1
12	WASHER, 10.5 FLAT ZINC	F81055-1	1
13	WASHER, 8.4 FLAT ZINC	F81054-1	9
14	CIRCLIP, 7 DIN6799	F81090-60	1
15	BOLT, M8X75 DIN603 ZINC MUSHROOM HEAD SQUARE NECK	F81002-106	2
16	BOLT, M8X25-8.8-B HEX HEAD FULL THREAD ZINC	F81002-5	2