

**Wood-Mizer®**  
**E11 Electric Option**  
**Safety, Operation, Maintenance**  
**& Parts Manual**

---

**LT15**

**rev. C2.01**

---



**Safety is our #1 concern!** Read and understand all safety information and instructions before operating, setting up or maintaining this machine.

*September 1997*

*Form #830*

## **CAUTION!**

The electric motor which operates the saw blade is capable of developing horsepower up to two or more times the horsepower listed on the motor nameplate. While the mill design allows for using this increased horsepower intermittently while sawing, it is possible in very aggressive cutting to overload the motor. Aggressive sawing for long periods may cause excessive heat buildup. An internal thermal protection device has been installed to ensure no damage to the motor can result from this overloading. This device shuts off the motor when its internal operating temperature becomes too hot. The motor will operate normally again after it cools (approximately 20 to 30 minutes).

# Table of Contents

# Section-Page

<b>SECTION 1</b>	<b>SAFETY &amp; GENERAL INFORMATION</b>	<b>1-1</b>
1.1	Motor Operation .....	1-2
<b>SECTION 2</b>	<b>OPERATION</b>	<b>2-1</b>
2.1	Starting The Motor .....	2-1
2.2	Changing The Blade Rotation Direction .....	2-2
<b>SECTION 3</b>	<b>MAINTENANCE</b>	<b>3-1</b>
3.1	Drive Belt Adjustment.....	3-1
<b>SECTION 4</b>	<b>REPLACEMENT PARTS</b>	<b>4-1</b>
4.1	How To Use The Parts List .....	4-1
4.2	Sample Assembly .....	4-1
4.3	Motor Assembly .....	4-2
<b>SECTION 5</b>	<b>ELECTRICAL INFORMATION</b>	<b>5-1</b>
5.1	Electrical Symbol Diagram, LT15 E11 With AC Debarker And SW-08 Setworks .	5-1
5.2	Electrical Symbol Diagram, LT15 E11 (African Version) .....	5-2
5.3	Electrical Component List .....	5-3
5.4	Component Layout Diagram, LT15 E11 .....	5-4

## SECTION 1 SAFETY & GENERAL INFORMATION



**IMPORTANT!** This manual is provided as a supplement to the equipment manufacturer's manuals. This manual takes into account the specific use of engines on the Wood-Mizer sawmill. Only safety, maintenance, and operating procedures that are not provided by the manufacturer are supplied in this manual. Refer to the manufacturer's manual before attempting to operate this equipment.



This symbol calls your attention to instructions concerning your personal safety. Be sure to observe and follow these instructions. This symbol accompanies a signal word. The word **DANGER** indicates an imminently hazardous situation which, if not avoided, will result in death or serious injury. **WARNING** suggests a potentially hazardous situation which, if not avoided, could result in death or serious injury. **CAUTION** refers to potentially hazardous situations which, if not avoided, may result in minor or moderate injury to persons or equipment. Read all safety instructions before operating this equipment and observe all safety warnings!

## 1.1 Motor Operation



**DANGER!** Always be sure the blade is disengaged and all persons are out of the path of the blade before starting the engine or motor. Failure to do so will result in serious injury.



**WARNING!** Hazardous voltage inside the disconnect box, starter box, and at the electric motor can cause shock, burns, or death. Disconnect power supply before servicing!

**WARNING!** Do not for any reason adjust the engine drive belts or belt support bracket with the engine running. Doing so may result in serious injury.

**WARNING!** Remove the blade before performing any engine service. Failure to do so may result in serious injury.

**WARNING!** Always wear proper and necessary safety equipment when performing service functions. Proper safety equipment includes eye protection, breathing protection, hand protection and foot protection.



**IMPORTANT!** Make sure the power cords are free to travel the length of the machine. An overhead boom system to keep the cords off of the floor is recommended.

## SECTION 2 OPERATION

Observe all safety instructions included in the sawmill operator's manual. Do not let the motor idle for a period longer than it is necessary. Doing so may cause the drive belts to burn and to smoke and consequently it can lead to their breakage.

### 2.1 Starting The Motor



**DANGER!** Make sure all guards and covers are in place and secured before starting the sawmill. Failure to do so may result in serious personal injury. Be sure the blade housing covers are closed and secured.



**WARNING!** Always wear proper and necessary safety equipment when performing service functions. Proper safety equipment includes eye protection, breathing protection, hand protection and foot protection.

To start the blade motor, turn on the main switch. When the power is on, the control light on the front wall of the starter box comes on. Press and hold the green safety button located on the control box. Press the START button. The drive motor starts when the windings are configured as Wye. After a few seconds the windings switch to Delta. The sawmill is ready to operate.

To stop the motor, release the green safety button.



**CAUTION!** Press the emergency stop button to stop the blade motor immediately. On LT15 sawmills, the emergency stop switch is located on the electric box.

## 2.2 Changing The Blade Rotation Direction

After starting the electric motor sawmill, make sure the blade rotation direction is in accordance with the arrow located on the blade housing cover.

If the blade rotation direction is incorrect, turn off the blade motor using the STOP button on the control box. Disconnect the power supply using the main switch and remove the power cord plug from the socket located on the electric box wall.

Insert a screwdriver into the slot of the phase converter switch (red disk viewed from the bottom of the socket) and turn the switch to the right or to the left until the two socket pins turn 180°. This will convert the motor phases and change the blade rotation direction.

## SECTION 3 MAINTENANCE

 **This symbol** identifies the interval (hours of operation) which each maintenance procedure should be performed. "AR" signifies maintenance procedures which should be performed as required.

### 3.1 Drive Belt Adjustment

 Periodically check all belts for wear. Replace any damaged or worn belts as needed.

 **DANGER!** Do not for any reason adjust the drive belt support with the motor running. Always stop the motor before reaching or looking into the drive belt area.



## SECTION 4 REPLACEMENT PARTS

### 4.1 How To Use The Parts List

- Use the table of contents or the index to locate the assembly that contains the part you need.
- Go to the appropriate section and locate the part in the illustration.
- Use the number pointing to the part to locate the correct part number and description in the table.
- Parts shown indented under another part are included with that part.
- Parts marked with a diamond (◆) are only available in the assembly listed above the part.

See the sample table below. Sample Part #A01111 includes part F02222-2 and subassembly A03333. Subassembly A03333 includes part S04444-4 and subassembly K05555. The diamond (◆) indicates that S04444-4 is not available except in subassembly A03333. Subassembly K05555 includes parts M06666 and F07777-77. The diamond (◆) indicates M06666 is not available except in subassembly K05555.

<b>4.2 Sample Assembly</b>				
REF	DESCRIPTION (◆ Indicates Parts Available In Assemblies Only)	PART #	QTY.	
	<b>SAMPLE ASSEMBLY, COMPLETE (INCLUDES ALL INDENTED PARTS BELOW)</b>	A01111	1	
1	Sample Part	F02222-22	1	
	Sample Subassembly (Includes All Indented Parts Below)	A03333	1	
2	Sample Part (◆ Indicates Part Is Only Available With A03333)	S04444-4	1	◆
	Sample Subassembly (Includes All Indented Parts Below)	K05555	1	
3	Sample Part (◆ Indicates Part Is Only Available With K05555)	M06666	2	◆
4	Sample Part	F07777-77	1	

#### To Order Parts:

- From Europe call our European Headquarters and Manufacturing Facility in Kolo, Poland at **+48-63-2610233** or **+48-3912-1319**. From the continental U.S., call **1-800-448-7881** to order parts. Have your customer number, vehicle identification number, and part numbers ready when you call.
- From other international locations, contact the Wood-Mizer distributor in your area for parts.

# 4 Replacement Parts

## Motor Assembly

### 4.3 Motor Assembly

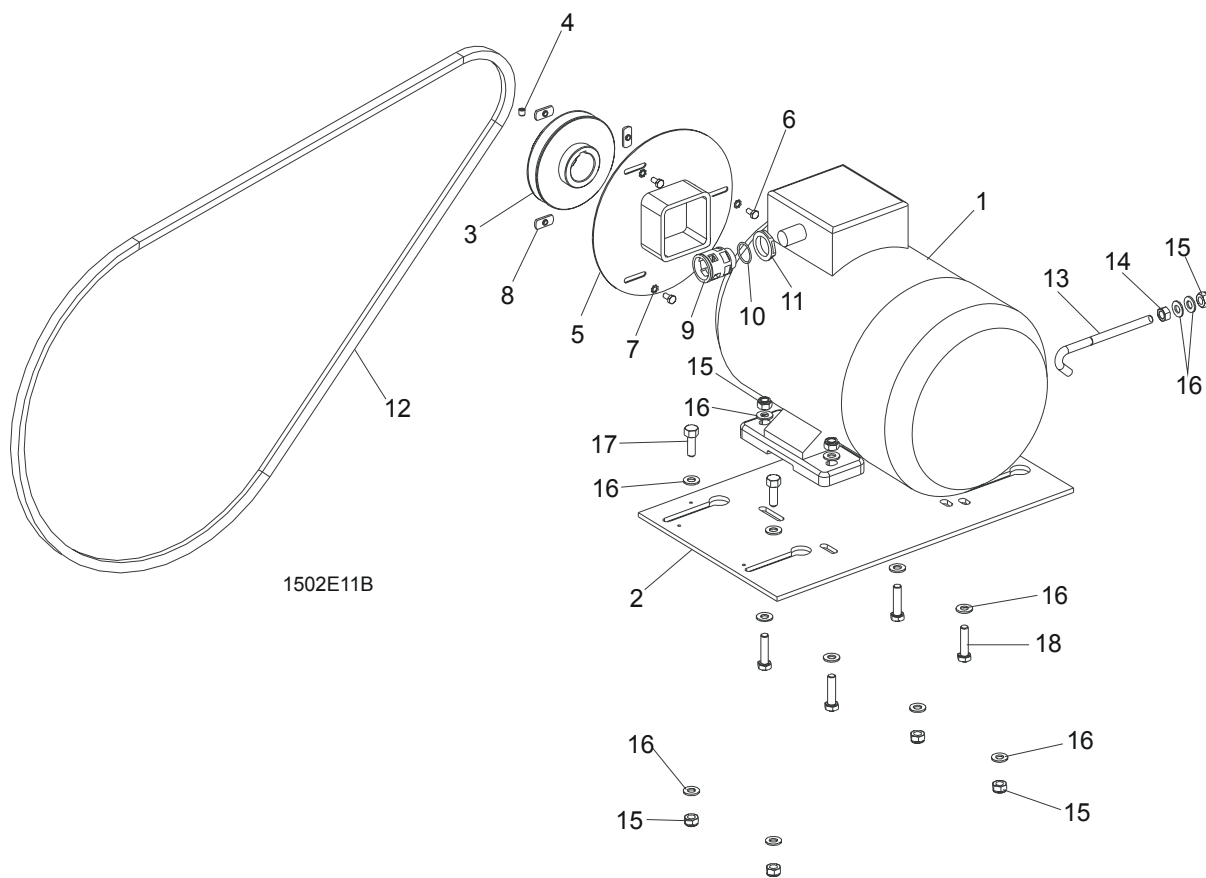

REF	DESCRIPTION (◆ Indicates Parts Available In Assemblies Only)	PART #	QTY.	
	<b>MOTOR ASSEMBLY, LT15</b>	EP11	1	
1	Motor, 3-Phase 11KM/380V/50Hz	085482	1	
	Motor, 3-Phase 11KM/415V (England Only)	085482-1	1	
	Motor, 3-Phase 11KM/230V (Norway Only)	085482-2	1	
2	Plate, LT15 G13 Engine / E11 Motor	091926-1	1	
3	Pulley, LT15 E11 Belt	086807-1	1	
4	Screw, M8 x 8-33H	F81014-1	1	
5	Guard, LT15 Shaft	091684-1	1	
6	Bolt, M6 x 12-8.8 Hex Head	F81001-7	3	
7	Washer, 6.4 External Star	F81053-2	3	
8	Nut, M6 x 1	F81031-3	3	

<b>9</b>	Connector, Click-GP21	086577	1	
<b>10</b>	Ring, 021 N°5200 5750	086578	1	
<b>11</b>	Ring, GMP-GL 21 N°53019050	086579	1	
<b>12</b>	Belt, BX81	014819	1	
<b>13</b>	Rod, Belt Tension Adjustment	086794-1	1	
<b>14</b>	Nut, M10-8-B	F81033-3	1	
<b>15</b>	Nut, M10-8-B Hex Nylon Lock	F81033-1	9	
<b>16</b>	Washer, 10.5 Flat	F81055-1	18	
<b>17</b>	Bolt, M10 x 30-10.9 Hex Head	F81003-25	4	
<b>18</b>	Bolt, M10X45mm Hex Head BOLT, Full Thrd, Zinc	F81003-3	4	

## SECTION 5 ELECTRICAL INFORMATION

### 5.1 Electrical Symbol Diagram, LT15 E11 With AC Debarker And SW-08 Networks

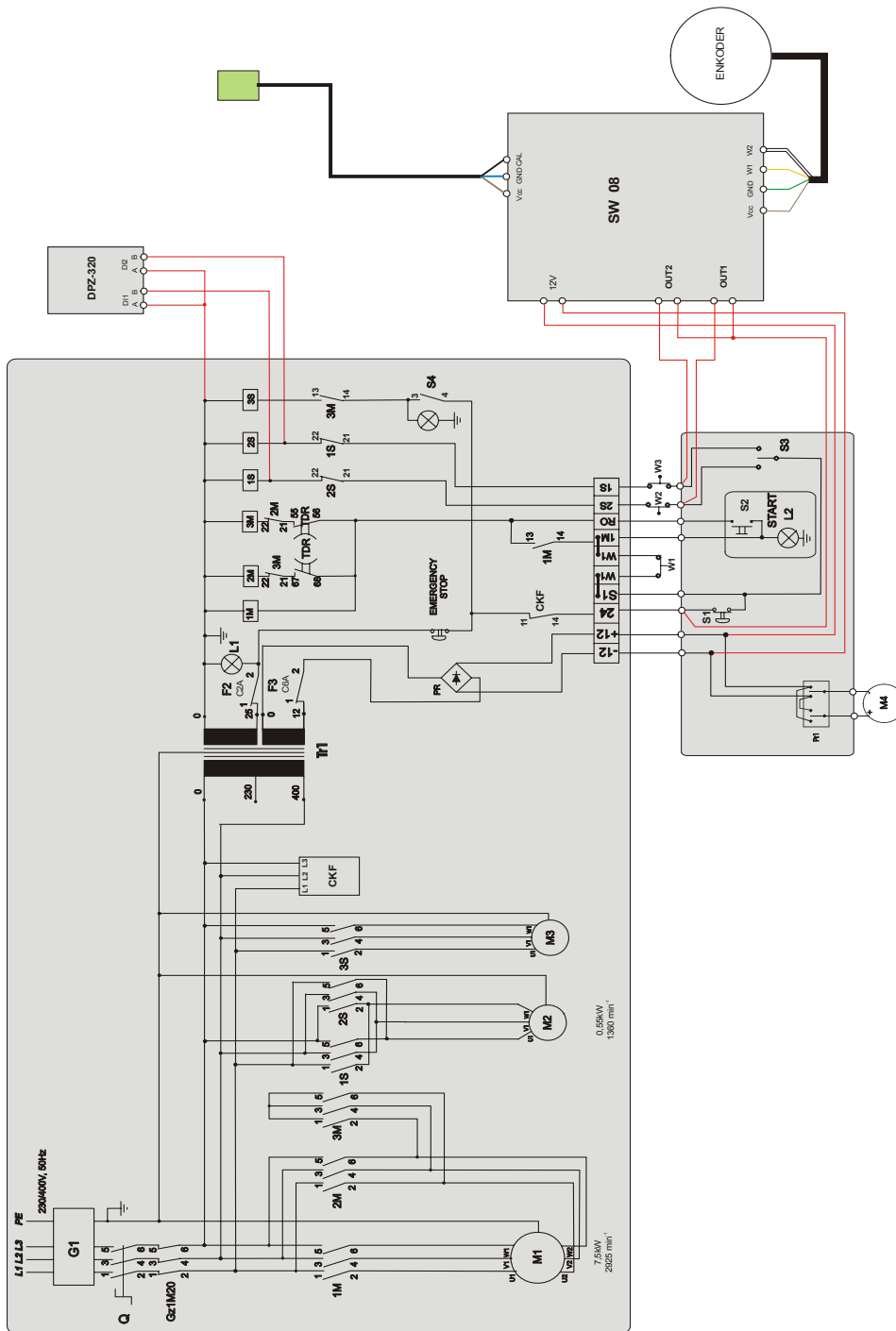

FIG. 5-0

**Limit Switches:** DS1 and DS2 - located on the blade guards, LS1 - activated by the hand grip

## 5.2 Electrical Symbol Diagram, LT15 E11 (African Version)

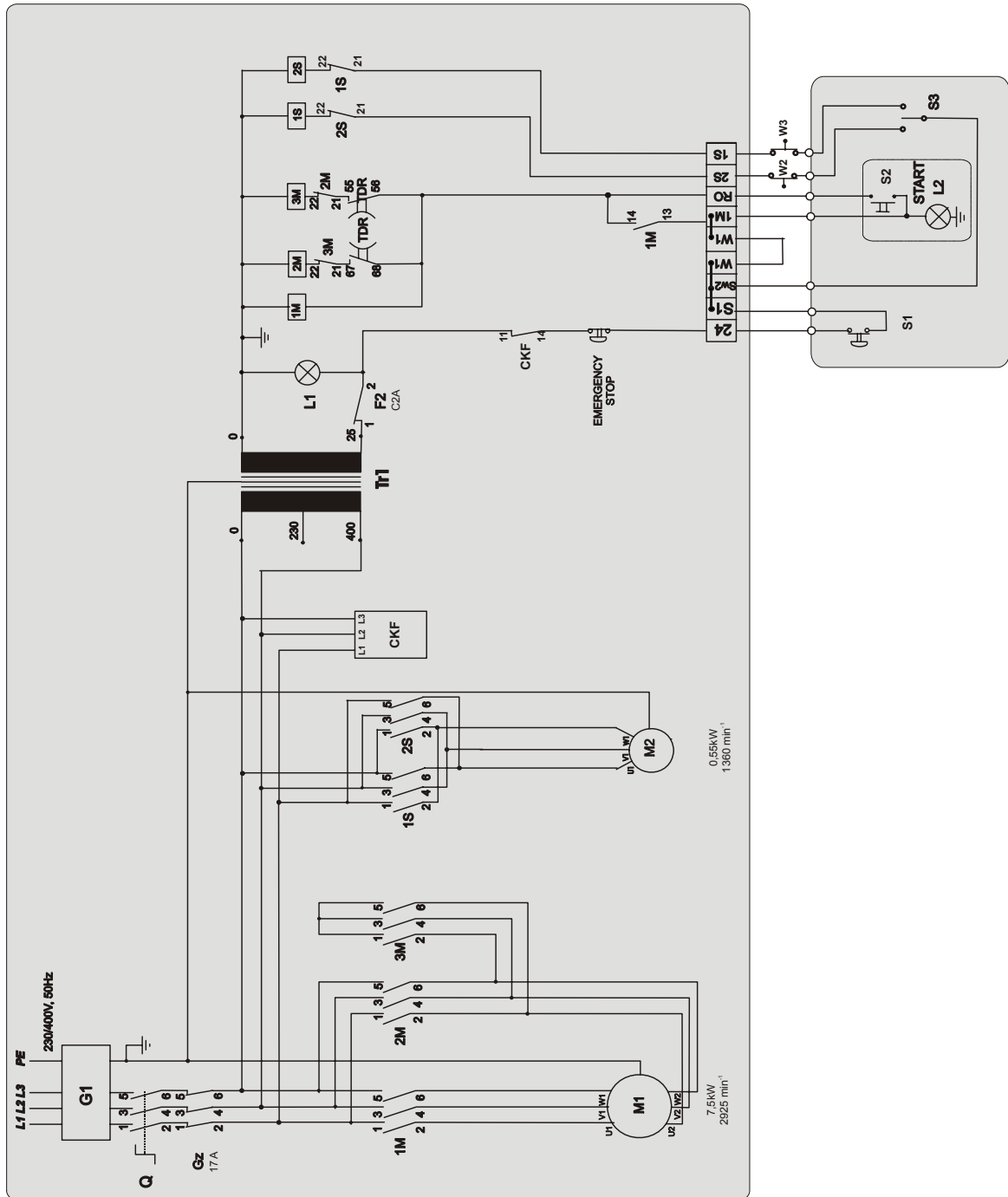

FIG. 5-0

### 5.3 Electrical Component List

ID	Mfg. Part No.	Manufacturer	Wood-Mizer Part #	Description
<b>GZ</b>	GZ1 M20	SCHNEIDER ELECTRIC	090561	Switch, Motor On/Off
<b>F2</b>	C60N C2 24396	SCHNEIDER ELECTRIC	088278	Switch, Modular
<b>Q</b>	ABB OT16E3	ABB	089801	Disconnecter
<b>TR</b>	TMM 80/A	BREVE	096917	Transformer TMM 80/A
<b>1M, 2M, 3M</b>	LC1 D09 B7	SCHNEIDER ELECTRIC	094805	Contactator
<b>1S, 2S, 3S</b>	LC1K0601	SCHNEIDER ELECTRIC	084309	Contactator
<b>TDR</b>	LAD S2	SCHNEIDER ELECTRIC	084037	Relay, Time
<b>L1</b>	M22	MOELLER	090448	Control Light M22 White-LED 24V
<b>S1</b>	M22-DP-R	MOELLER	094328	Safety Switch
<b>S2/L2</b>	M22-XDL-G	MOELLER	094315	Start Button
<b>S3</b>	M22-DDL-S-X7/X7	MOELLER	090917	Up/Down Button
<b>S4</b>	M22	MOELLER	091467	Switch, 2-Position Illuminated
<b>M1</b>	1LA7131-2AA60	SIEMENS	085482	Blade Drive Motor
<b>M2</b>	Skh71X 4C2	BESEL	091186	Up/Down Drive Motor
<b>W1</b>	AZ17-11ZRK	SCHMERSAL	094232	Safety Disconnecter (Only CE Version)
<b>W2, W3</b>	EVN2000C	HONEYWELL	089816	Switch, EVN2000 C Limit
<b>CKF</b>	RM4 TG20	SCHNEIDER ELECTRIC	084452	Phase Supply Control Relay RM3 TG201

**TABLE 5-1**

### 5.4 Component Layout Diagram, LT15 E11

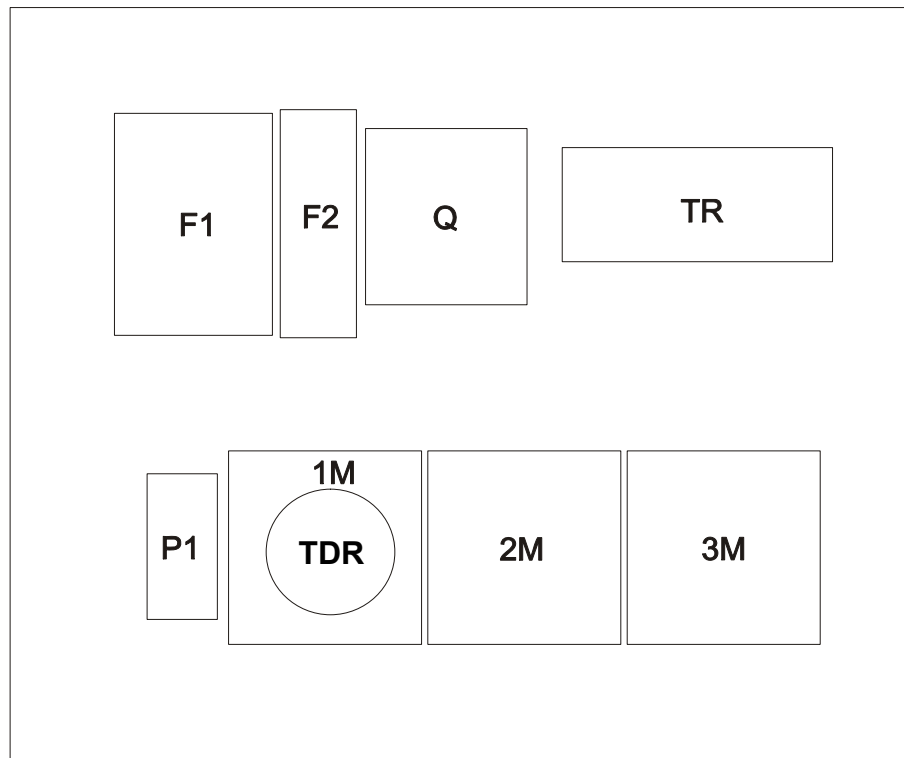

15PL03

FIG. 5-1