

# **G28 Engine**

## **Safety, Operation, Maintenance & Parts Manual**

---

**LT40 Series**

**rev. E5.00**

---



**Safety is our #1 concern!** Read and understand all safety information and instructions before operating, setting up or maintaining this machine.

*September 2003*

*Form #827*

# Table of Contents

# Section-Page

<b>SECTION 1</b>	<b>OPERATION</b>	<b>1-1</b>
1.1	Starting The Engine .....	1-1
<b>SECTION 2</b>	<b>MAINTENANCE</b>	<b>2-1</b>
2.1	Safety .....	2-1
2.2	Engine Oil & Filter .....	2-2
2.3	Cooling System .....	2-2
2.4	Air Filter & Pre-Cleaner .....	2-2
2.5	Fuel Filter .....	2-2
2.6	Battery .....	2-3
2.7	Alternator Belt .....	2-4
2.8	RPM Adjustments .....	2-5
2.9	Drive Belt Adjustment .....	2-6
2.10	Clutch Handle Adjustment .....	2-7
2.11	Miscellaneous Maintenance .....	2-8
<b>SECTION 3</b>	<b>REPLACEMENT PARTS</b>	<b>3-1</b>
3.1	Fuel Tank Assembly .....	3-1
3.2	Engine Mount Assembly .....	3-2
3.3	G28 Engine Assembly .....	3-3
3.4	Alternator Assembly .....	3-6
3.5	Engine Pulley Guards .....	3-8
<b>SECTION 4</b>	<b>ELECTRICAL INFORMATION</b>	<b>4-1</b>
4.1	Electrical Symbol Diagram, G28 LT40 Series .....	4-1
4.2	Electrical Symbol Diagram, LT40 Series .....	4-2
4.3	Electrical Components, G28 LT40 Non-hydraulic .....	4-3
4.4	Electrical Components, G28 LT40 Hydraulic .....	4-4

## SECTION 1 OPERATION

### 1.1 Starting The Engine

#### Engine Control Lights

See **Figure 1-1**. The following indicator lights are located on the sawmill control panel.



*Alternator Charge Indicator:* Lights up if the alternator is not charging the battery.



*Engine Temperature Indicator:* Lights up if the engine is overheating. A circuit breaker assembly in the engine harness will shut the engine off if the engine overheats. Turn the key switch off and allow the engine to cool for a period of time before restarting. If the overheating condition persists, stop operating the engine until the condition is corrected. The engine will automatically switch to low idle if an overheating condition occurs.



*Oil Indicator:* Lights up if the oil pressure is too low.

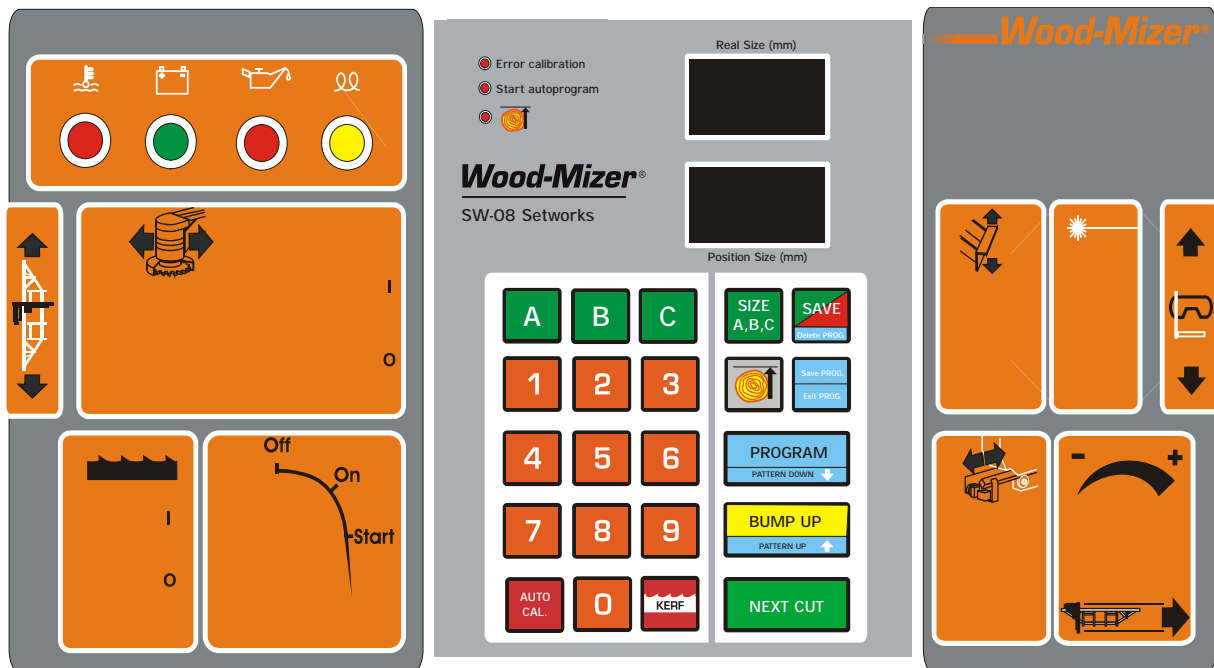

FIG. 1-1

**Engine Start**

**DANGER!** Always be sure the blade is disengaged and all persons are out of the path of the blade before starting the engine. Failure to do so will result in serious injury.

**DANGER!** Operate your engine/machine only in well ventilated areas. The exhaust gases of your engine can cause nausea, delirium and potentially death unless adequate ventilation is present.

**DANGER!** Never operate an engine with a fuel or oil leak. The leaking fuel or oil could potentially come in contact with hot surfaces and ignite into flames.



**WARNING!** Be sure the power feed switch is in the neutral position before turning the key switch to the on (#1) or accessory (#3) position. This prevents accidental carriage movement, which may cause serious injury or death.

**WARNING!** Do not operate engine without proper and operational spark arrester/muffler. Sparks emitted from the engine exhaust could ignite surrounding materials, causing serious injury or death.

Turn the key switch to the start (#2) position and release.

### **Engine Shutoff**

Turn the key switch to the off (#0) position.

## SECTION 2 MAINTENANCE

Refer to the manufacturer's manual for maintenance intervals and procedures unless otherwise instructed in this manual. Follow the manufacturer's recommendations for dusty conditions.



**IMPORTANT!** This manual only provides information about additional procedures or procedures to be performed at different time intervals than found in the manufacturer's manuals. Refer to the manufacturer's manual for complete maintenance instructions.

### 2.1 Safety

Use caution when performing maintenance or service to the engine.



**DANGER!** Always be aware of and take proper protective measures against rotating shafts, pulleys, fans, etc. Always stay a safe distance from rotating members and make sure that loose clothing or long hair does not engage rotating members resulting in possible injury.

**DANGER!** Engine components can become very hot during operation. Avoid contact with any part of a hot engine. The exhaust components of your engine are especially hot during and following operation. Contact with hot engine components can cause serious burns. Therefore, never touch or perform service functions on a hot engine. Allow the engine to cool sufficiently before beginning any service function.



**WARNING!** Remove the blade before performing any engine service. Failure to do so may result in serious injury.



**WARNING!** Always wear proper and necessary safety equipment when performing service functions. Proper safety equipment includes eye protection, breathing protection, hand protection and foot protection.



**This symbol** identifies the interval (hours of operation) at which each maintenance procedure should be performed. "AR" signifies maintenance procedures which should be performed as required.

## 2.2 Engine Oil & Filter

 Check the oil level every 8 hours of operation. Add oil as necessary. See the engine manual for oil viscosity and grade recommendations.

  **IMPORTANT!** During initial break-in, change the oil and the oil filter after the first 5 hours and every 50 hours thereafter. Continue to check oil level every 8 hours of operation and refill as necessary.

**NOTE:** Engine in factory is filled with 5W/40 Shell Helix Ultra, full synthetic oil.

## 2.3 Cooling System

 Wash the engine or brush off sawdust and debris every 50 hours of operation. Clean the grass screen, cooling fins, and external surfaces. Remove any dust, dirt or oil. See engine manual for further instructions.

## 2.4 Air Filter & Pre-Cleaner

 **WARNING!** Always wear proper and necessary safety equipment when performing service functions. Proper safety equipment includes eye protection, breathing protection, hand protection and foot protection.

 Service the pre-cleaner every four hours of operation. Service by gently shaking excess sawdust and debris from the foam piece.

 Clean the air filter (air cleaner element) and pre-cleaner (element wrapper) every eight hours of operation. See the engine manual for further instructions.

 Replace the air filter (cleaner) every 200 hours of operation.

 Replace the pre-cleaner (element wrapper) every 2000 hours of operation.

## 2.5 Fuel Filter

 Replace the fuel filter every 100 hours of operation.

## 2.6 Battery



Check the battery electrolyte level every 50 hours of operation. See manufacturer's manual for instructions.



**DANGER!** Batteries expel explosive gases. Keep sparks, flames, burning cigarettes, or other ignition sources away at all times. Always wear safety goggles and a face shield when working near batteries. Failure to do so will cause serious injury.<sup>1</sup>



**WARNING!** Battery posts, terminals and related accessories contain lead and lead compounds, chemicals known to the State of California to cause cancer and reproductive harm. Wash hands after handling.

---

1. Battery Council International, copyright 1987



## 2.7 Alternator Belt



Adjust the alternator belt as needed. Check the alternator belt for tension and wear when battery is not charging properly or when the alternator belt is squealing. To tighten the belt, loosen the adjustment bolt and lock washer. Pivot the alternator away from the motor until the belt has 7/16" (11 mm) deflection with a 5 lb. deflection force. Retighten the adjustment bolt.

See Figure 2-1.

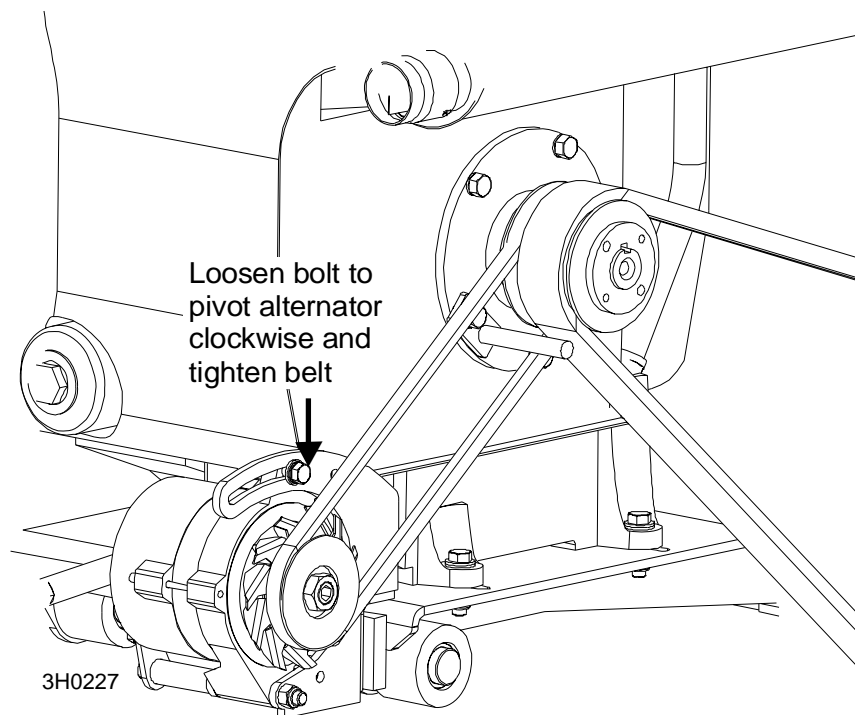

FIG. 2-1

## 2.8 RPM Adjustments



**WARNING!** Remove the blade before performing any engine service. Failure to do so may result in serious injury.



Check the RPM with a tachometer after the first 20 hours of operation and every 200 hours thereafter. High-end RPM should be 3750 RPM and low-end RPM should be 1800 RPM ( $\pm 100$ ).

Before checking the RPM, make sure belt and brake strap tensions are correct (See Sawmill Maintenance). Also check oil, fuel, and coolant levels.

Make sure the throttle cable does not affect the engine RPM when the clutch handle is disengaged. Make sure the cable is not bent or kinked. Check that the cable spring, cable guide, cable, and throttle brackets are aligned. **NOTE:** It is important that the above components are aligned. Proper alignment allows any slack in the cable (when engine is idling) to slide down into the cable spring. This maintains free operation of the cable and prevents the cable from kinking. Make sure the shoulder bolt does not rub against the crankcase vent tube.

1. Start the engine to measure the low-end RPM.
2. Refer to the engine manual to adjust the low-end RPM.
3. Engage the clutch handle to throttle the engine and measure the high-end RPM. The high-end RPM is factory-set at 3750. Readjust the throttle cable if necessary to increase or reduce the high-end engine speed.

The throttle cable should be tensioned just enough so that the engine revs as soon as the clutch/brake handle is engaged. **NOTE:** A properly adjusted throttle will extend the cable spring 1/4" to 3/8" (6.4 - 9.5 mm) when running and have a slight amount of slack in the cable when idling.

## 2.9 Drive Belt Adjustment



**WARNING!** Do not for any reason adjust the engine drive belts or belt support bracket with the engine running. Doing so may result in serious injury.

50

Check the drive belt tension after the first 20 hours, and every 50 hours thereafter. When engaged, the drive belt should have 7/16" (11 mm) deflection with a 15 lb. deflection force (67 N).

To adjust drive belt tension:

1. Loosen the drive belt turnbuckle jam nuts. Turn the turnbuckle counterclockwise (as viewed from the top) to tighten the belts, clockwise to loosen the belts.

Patrz rysunek 2-2.

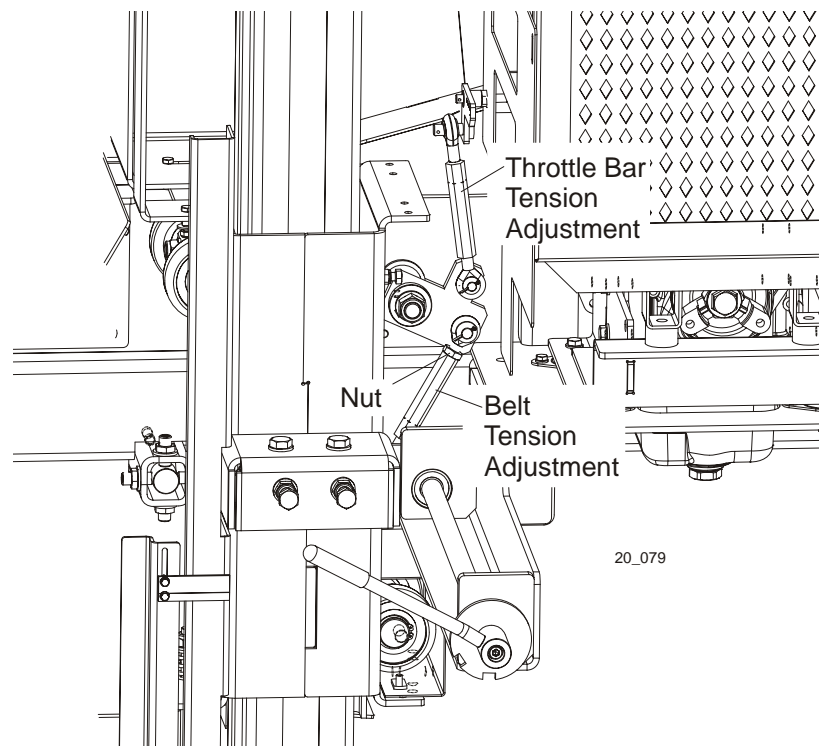

**RYS. 2-2**

AR

Periodically check all belts for wear. Replace any damaged or worn belts as needed.

## 2.10 Clutch Handle Adjustment

After the drive belts and brake strap are properly adjusted, the clutch handle should lock in the down position when the drive belts are engaged. If the clutch handle does not stay locked, adjust the handle turnbuckle.

Patrz rysunek 2-3.

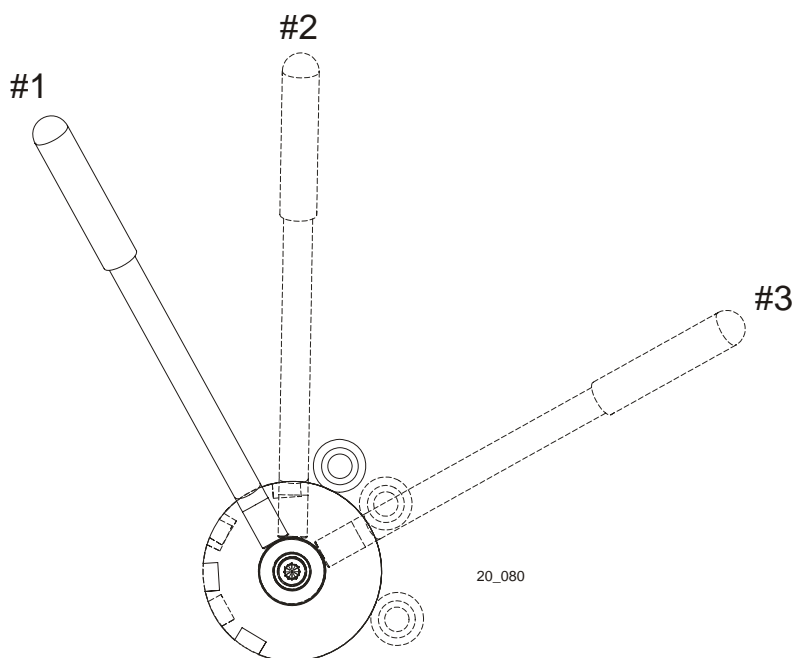

**RYS. 2-3**

#1 - Brake locked, belt loosened

#2 - Intermediate position (blade replacement): brake unlocked, drive not engaged

#3 - Belt tightened, drive engaged

## 2.11 Miscellaneous Maintenance

50

Clean and inspect the spark arresters every 50 hours of operation. Replace if damaged.

100

Inspect the spark plugs every 100 hours of operation. Remove any deposits and adjust gap if necessary. See engine manual for further information.



**CAUTION!** Do not remove the plug wire to check for electrical spark. Damage to the ignition circuit will result.

## SECTION 3 REPLACEMENT PARTS

### 3.1 Fuel Tank Assembly

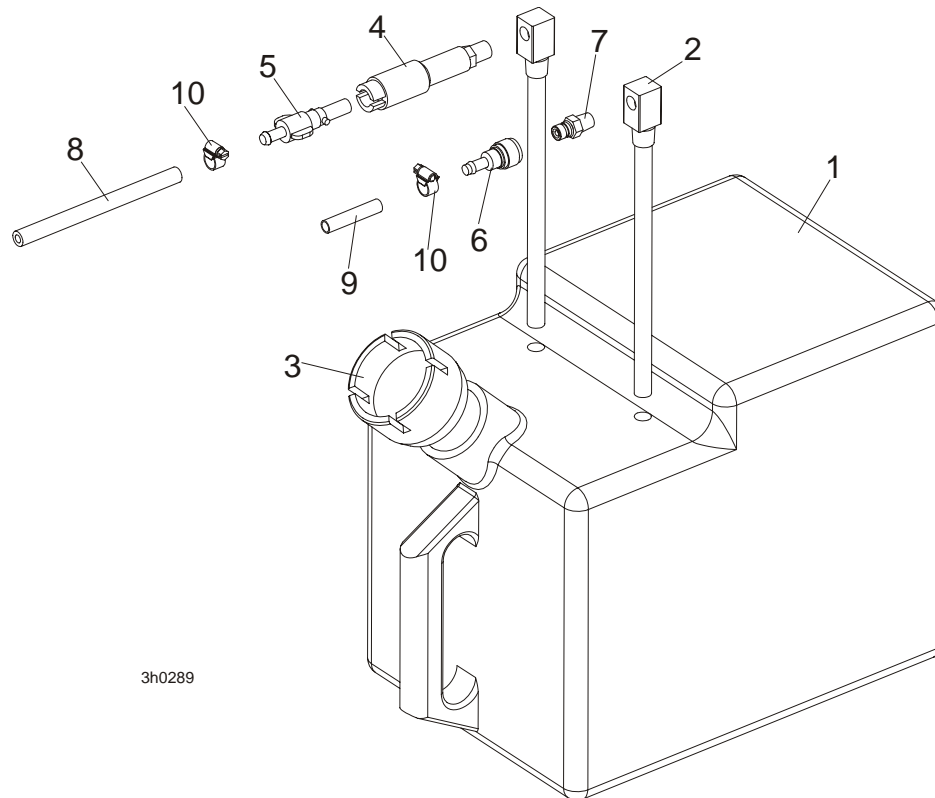

REF	DESCRIPTION (◆ Indicates Parts Available In Assemblies Only)	PART #	QTY.
	<b>TANK ASSEMBLY, G28</b>	098530	1
1	Tank, 5-Gallon Red Fuel	P12167	1
2	Fitting, 1/4NPTX9 Fuel Pick Up	P12172	2
3	Cap, 3 or 5-Gallon Fuel Tank	P09683	1
4	Fitting, 1/4" NPT Plastic Female Disconnect	P12175	1
5	Fitting, 1/4" NPT Plastic Male Disconnect	P12176	1
6	Fitting, Female Quick Disconnect Barb	015582	1
7	Fitting, 1/4 NPT Male Quick Disconnect	015583	1
8	Fuel Line, Diesel Engine	P642	1
9	Hose, Carburante 10mm Fuel	R80703-1	1
10	Clamp, Plastic Hose	F81080-1	2

### 3.2 Engine Mount Assembly

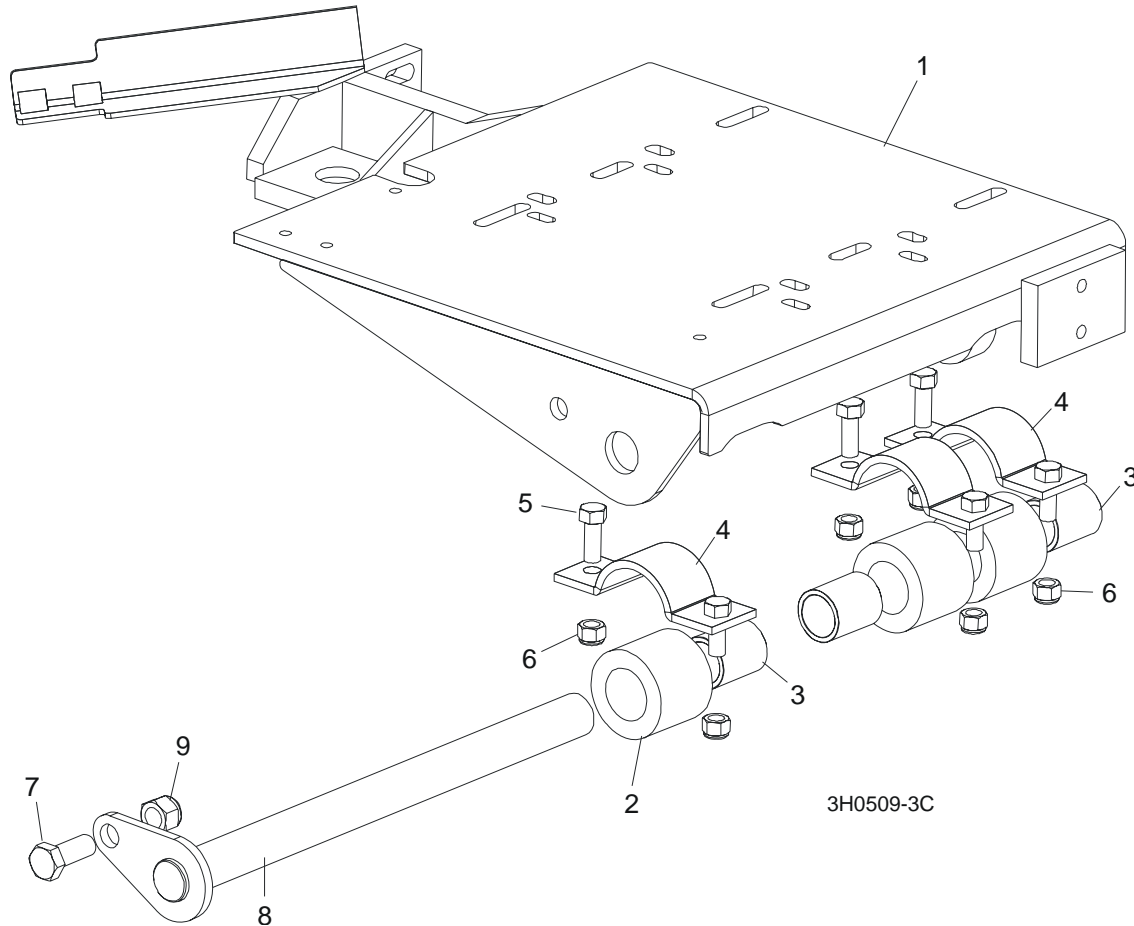

REF	DESCRIPTION (◆ Indicates Parts Available In Assemblies Only)	PART #	QTY.	
1	<b>MOUNT WELDMENT, KOHLER ENGINE</b>	086803-1	1	◆
	<b>BUSHING ASSEMBLY, MOTOR MOUNT</b>	016380	3	
2	Bushing, 2" OD x 2"	016378	1	◆
3	Bearing, 1" x 1 1/4" x 2"	016379	1	◆
4	<b>CLAMP WELDMENT , MOTOR MOUNT PIVOT BUSHING</b>	086235	3	
5	<b>BOLT, M10-1.5X25MM HH GR8.8</b>	F81003-11	3	
	<b>BOLT, M10X45MM,HEX HEAD,FULL THRD,ZINC</b>	F81003-31	3	
6	<b>NUT, M10, NYLON HEX ZINC LOCK</b>	F81033-11	6	
7	<b>BOLT M12X30-8.8</b>	F81004-22	1	
8	<b>PIN WELDMENT, ENGINE MOUNT PIVOT</b>	099130-1	1	
9	<b>NUT, M12, HEXAGON, NYLON, ZINC, LOCK</b>	F81034-2	1	
10	<b>WASHER, M12 , FLAT, ZINC</b>	F81056-1	1	

# 3 Replacement Parts

## G28 Engine Assembly

### 3.3 G28 Engine Assembly

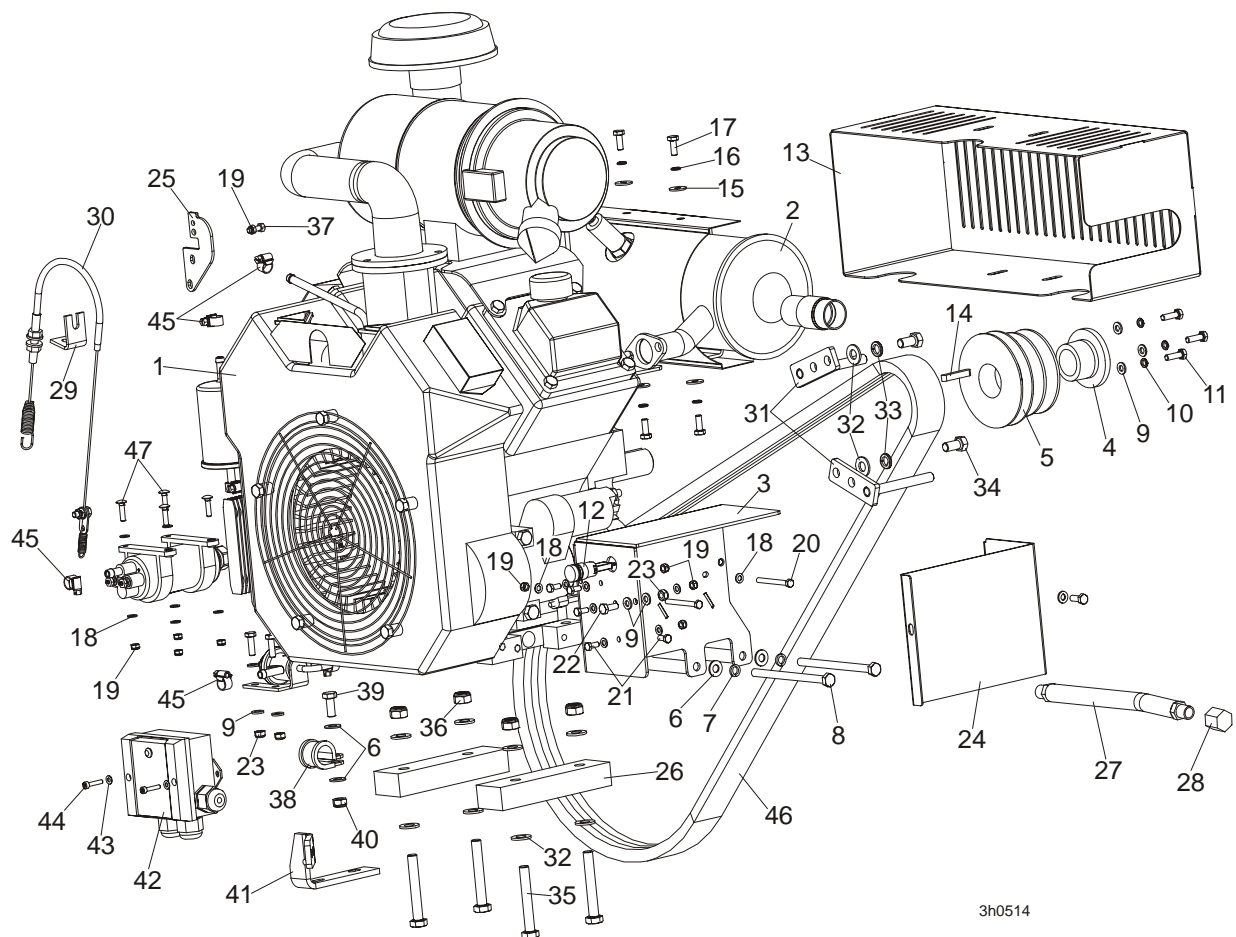

3h0514

REF	DESCRIPTION (◆ Indicates Parts Available In Assemblies Only)	PART #	QTY.
	<b>ENGINE ASSEMBLY, 28HP KOHLER</b>	098528	1
1	ENGINE, 28 HP KOHLER CH745	097844	1
2	Muffler, G28 Kohler	098529	1
	Filter, G28 Kohler Oil	098531	1
	Sensor, G28 Kohler Temperature	098532	1
	Cooler, G28 Kohler Oil	098533	1
	Sensor, G28 Kohler Oil Pressure	098534	1
	Seal Kit, G28 Kohler Head	098535	1
	Coil, G28 Kohler	098536	1
	Plug, G28 Kohler Spark	098537	1
	Injector, G28 Kohler Fuel	098538	1
	Module, G28 Kohler Injection	098539	1



	Pipe, G28 Kohler Suction	098540	1	
	Seal, G28 Kohler Muffler	098541	1	
	Filter, G28 Kohler Fuel	098542	1	
3	HOUSING, G28 ECU CONTROLLER	097845-1	1	
4	BUSHING, SPLIT TAPER	091572	1	
5	PULLEY, OXIDIZED	091566-1	1	
6	WASHER, 8.4 FLAT ZINC	F81054-1	4	
7	WASHER, 8.2 SPLIT LOCK ZINC	F81054-4	2	
8	BOLT, M8X120-8.8 HEX HEAD ZINC	F81002-25	2	
9	WASHER, 6.4 FLAT ZINC	F81053-1	10	
10	WASHER, Z6.1 SPLIT LOCK ZINC	F81053-3	3	
11	BOLT, M6x20-8.8 HEX HEAD FULL THREAD ZINC	F81001-2	3	
12	LIGHT, XB6AV4BB CONTROL RED	091099	1	
13	GUARD, MUFFLER COMPLETE-(GP25/GP18)	091859-1	1	
14	KEY, A 1/4"x1/4"x1,5" PARALLEL	092814	1	
15	WASHER, 6.5 FLAT ZINC	F81053-11	4	
16	WASHER, Z6.1 SPLIT LOCK ZINC	F81053-3	4	
17	BOLT, M6 x 16 8.8 Fe/Zn5 PN-M/82105	F81001-15	4	
18	WASHER, 5.3 FLAT ZINC	F81052-1	20	
19	NUT, M5-8-Fe/Zn5 DIN985	F81030-2	12	
20	BOLT, M5X50MM, HH, GR 8.8, ZINC	F81000-1	2	
21	BOLT, M5 X 12-5.8-Fe/Zn5, PN-M/82105	F81000-5	5	
22	BOLT, M6 x 16 8.8 Fe/Zn5 PN-M/82105	F81001-15	2	
23	NUT, M6-8-B HEX NYLON ZINC LOCK	F81031-2	5	
24	COVER, G28 SETWORK ECU HOUSING	098527-1	1	
25	BRACKET, G25 THROTTLE PAINTED	091565-1	1	
26	BAR, GP25 ENGINE MOUNT PTD	091564-1	2	
27	HOSE, 3/8NPTx9 5/8 RUBBER	P10082	1	
28	CAP, 3/8 PIPE GALVANIZE	P04332	1	
29	BRACKET, THROTTLE CABLE MOUNT PTD	091567-1	1	
30	CABLE, G28 KOHLER THROTTLE	092552	1	
31	BRACKET WELDMENT,GP25 DRIVE BELT SUPPORT	091582-1	2	
32	WASHER, 10.5 FLAT ZINC	F81055-1	10	
33	WASHER, 10.2 SPLIT LOCK ZINC	F81055-2	2	
34	BOLT, 3/8-16X3/4 HH GR2	F05007-27	2	
35	BOLT, M10 X 70-8.8 Fe/Zn5, PN-M/82105	F81003-20	4	
36	NUT, M10-8-B HEX NYLON ZINC LOCK	F81033-1	4	
37	BOLT, M5X16 -8.8- FE/ZN5 HEX HEAD FULL THREAT	F81000-20	1	
38	BRACKET, RSGU 1.20/20 W1 METAL-RUBBER	F81087-2	1	
39	BOLT, M8x20mm ,HH, GR 8.8, FULL THRD ZINC	F81002-1	1	
40	NUT, M8-8-B, HEX, NYLON LOCK ZINC	F81032-2	1	
41	BRACKET, THROTTLE CABLE SPRING PTD	091587-1	1	
42	RELAY, SAFETY KEY SWITCHES	092284	1	

**3****Replacement Parts***G28 Engine Assembly*

---

<b>43</b>	WASHER, 4.3 FLAT ZINC	F81051-2	2	
<b>44</b>	SCREW, M4X20 8.8 Fe/Zn5 HEX SOCKET HEAD	F81011-31	2	
<b>45</b>	CLAMP, PLASTIC HOSE	F81080-1	8	
<b>46</b>	BELT, 2BX72 DRIVE	P09555-2	1	
<b>47</b>	BOLT, M5x20-4.6 SPECIAL ZINC	F81000-29	4	

### 3.4 Alternator Assembly

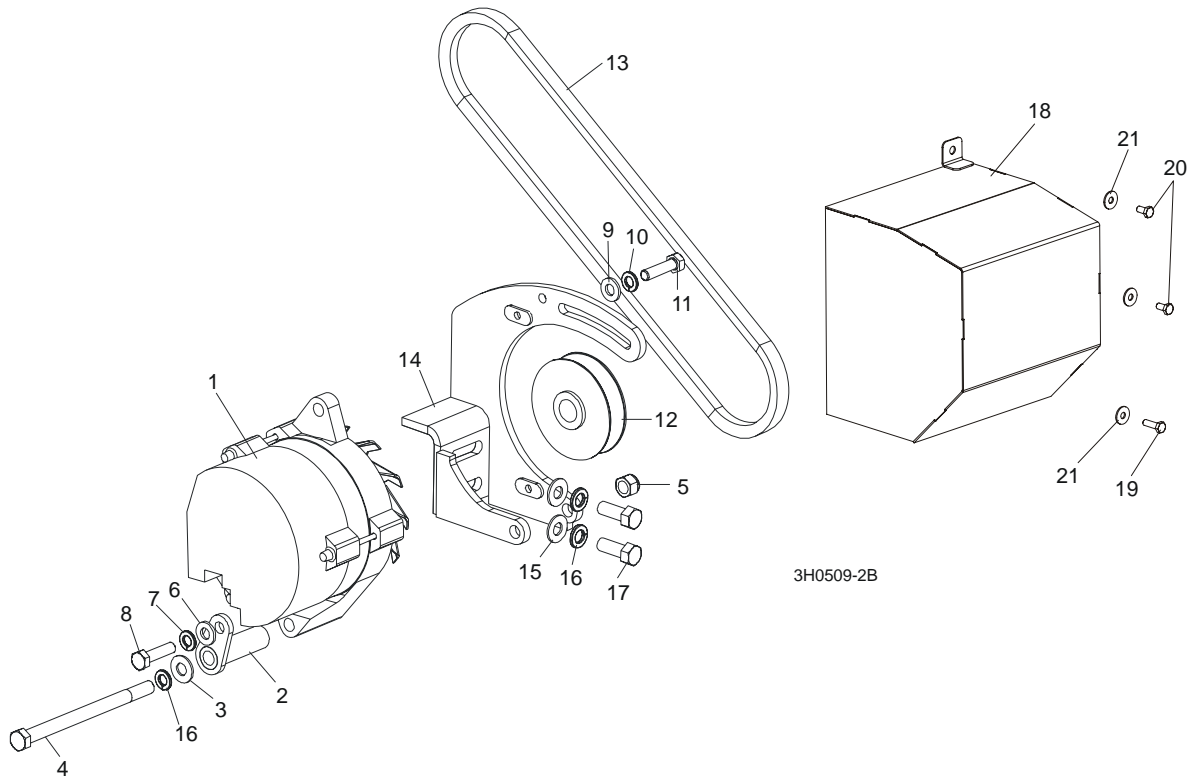

REF	DESCRIPTION (◆ Indicates Parts Available In Assemblies Only)	PART #	QTY.
1	ALTERNATOR, 12V 105A	050287	1
2	BRACE, ALTERNATOR	W12761	1
3	WASHER, FLAT, M10, ZINC	F81055-1	1
4	BOLT, 3/8-16 X 5 1/2" HEX HEAD FULL THREAD	F05007-34	1
5	NUT, 3/8-16 HEX NYLON LOCK	F05010-10	1
6	WASHER, M8, FLAT, ZINC	F81054-1	1
7	WASHER, 8,2 SPLIT LOCK ZINC	F81054-4	1
8	BOLT, M8 X 25MM HEX HEAD GR 5.8 ZINC	F81002-5	1
9	WASHER, M8, FLAT, ZINC	F81054-1	1
10	WASHER, 8,2 SPLIT LOCK ZINC	F81054-4	1
11	BOLT, M8 X 25MM HEX HEAD GR 5.8 ZINC	F81002-5	1
12	PULLEY, ALTERNATOR	P03806	1
13	BELT, ALTERNATOR E15 13X920 "A"	085753	1
	WIRE ASSEMBLY, G25 ALTERNATOR/STARTER	024308	1
	WIRE ASSEMBLY, 61/105 AMP ALTERNATOR PLUG	015969	1
14	BRACKET, ALTERNATOR MOUNT	092015-1	1

**3****Replacement Parts***Alternator Assembly*

---

15	WASHER, FLAT, M10, ZINC	F81055-1	2	
16	WASHER, M10 SPLIT LOCK ZINC	F81055-2	3	
17	BOLT, M10X20MM,HEX HEAD,GR 5.8 ZINC	F81003-1	2	
18	GUARD, ALTERNATOR BELT	091583-1	1	
19	BOLT, M6X20MM, HH, FULL THREAD, ZINC	F81001-2	1	
20	BOLT, M6X12MM HEX HEAD ZINC	F81001-7	2	
21	WASHER, M6, FLAT, ZINC	F81053-11	3	

### 3.5 Engine Pulley Guards

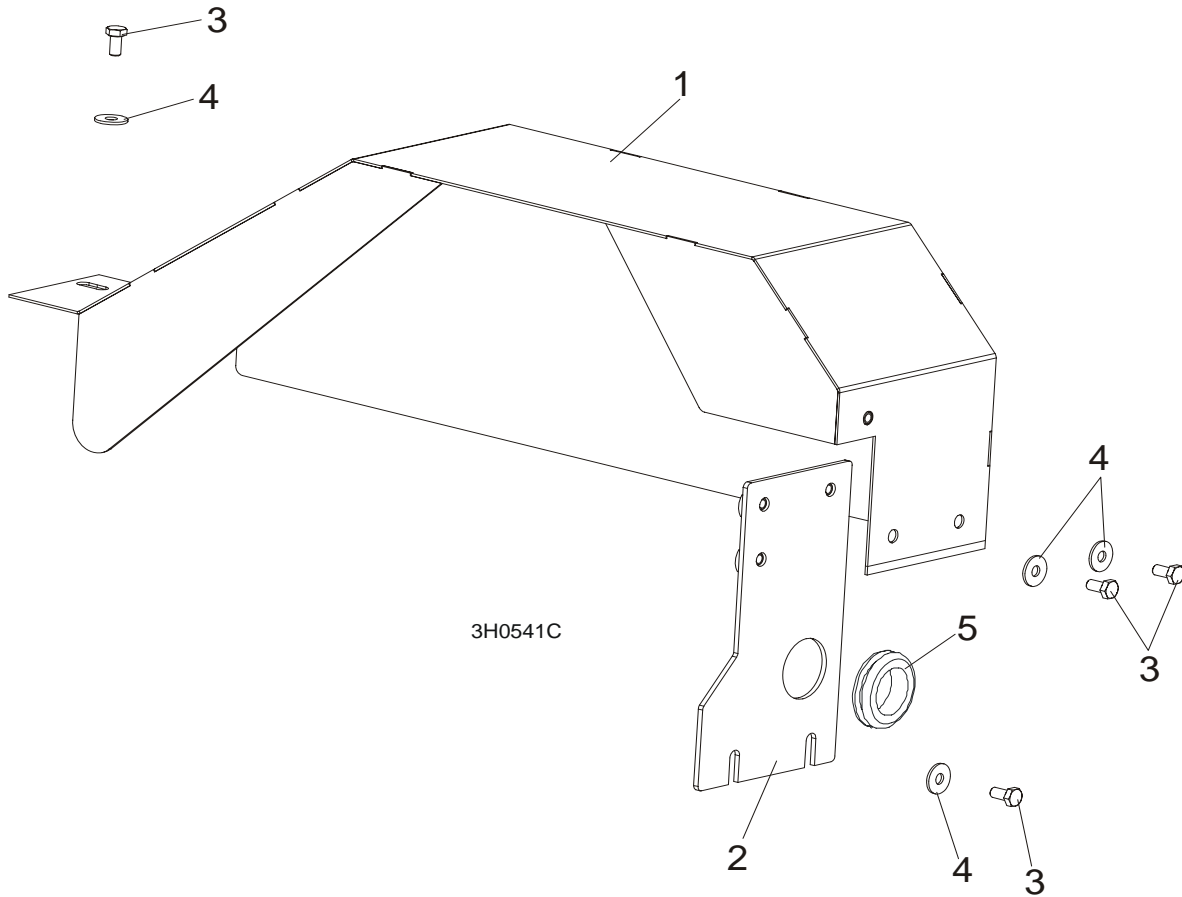

REF	DESCRIPTION (◆ Indicates Parts Available In Assemblies Only)	PART #	QTY.	
1	GUARD WELDMENT, G18/G20/G25 ENGINE PULLEY	091571-1	1	
2	GUARD, G18/G20/G25 SIDE ENGINE PULLEY	087178-1	1	
3	BOLT, M6X12MM HEX HEAD ZINC	F81001-7	4	
4	WASHER, M6, FLAT, ZINC	F81053-11	4	
5	GROMMET, 1 " ID RUBBER	P11765	1	

## SECTION 4 ELECTRICAL INFORMATION

### 4.1 Electrical Symbol Diagram, G28 LT40 Series

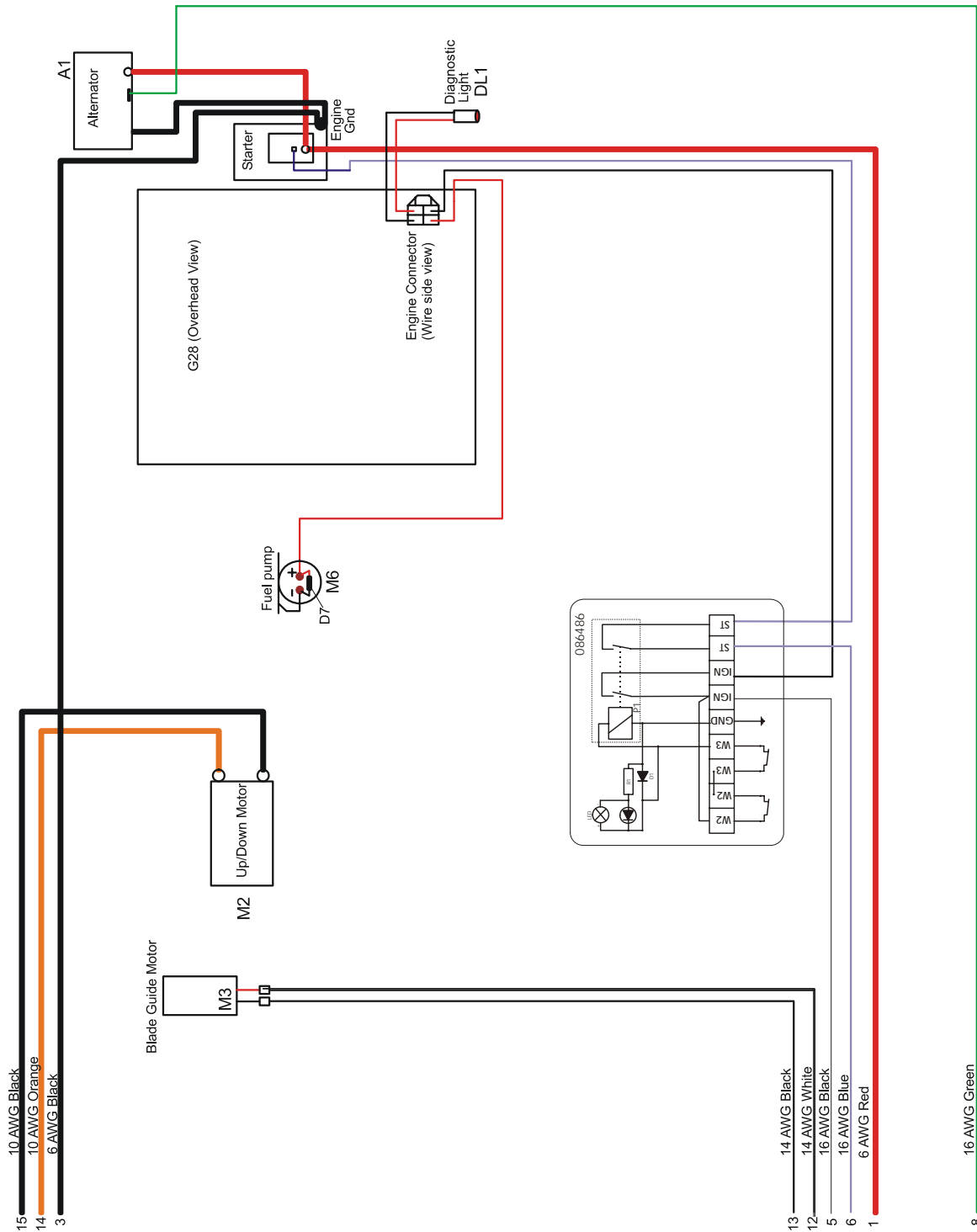

RYS. 4-1

## 4.2 Electrical Symbol Diagram, LT40 Series

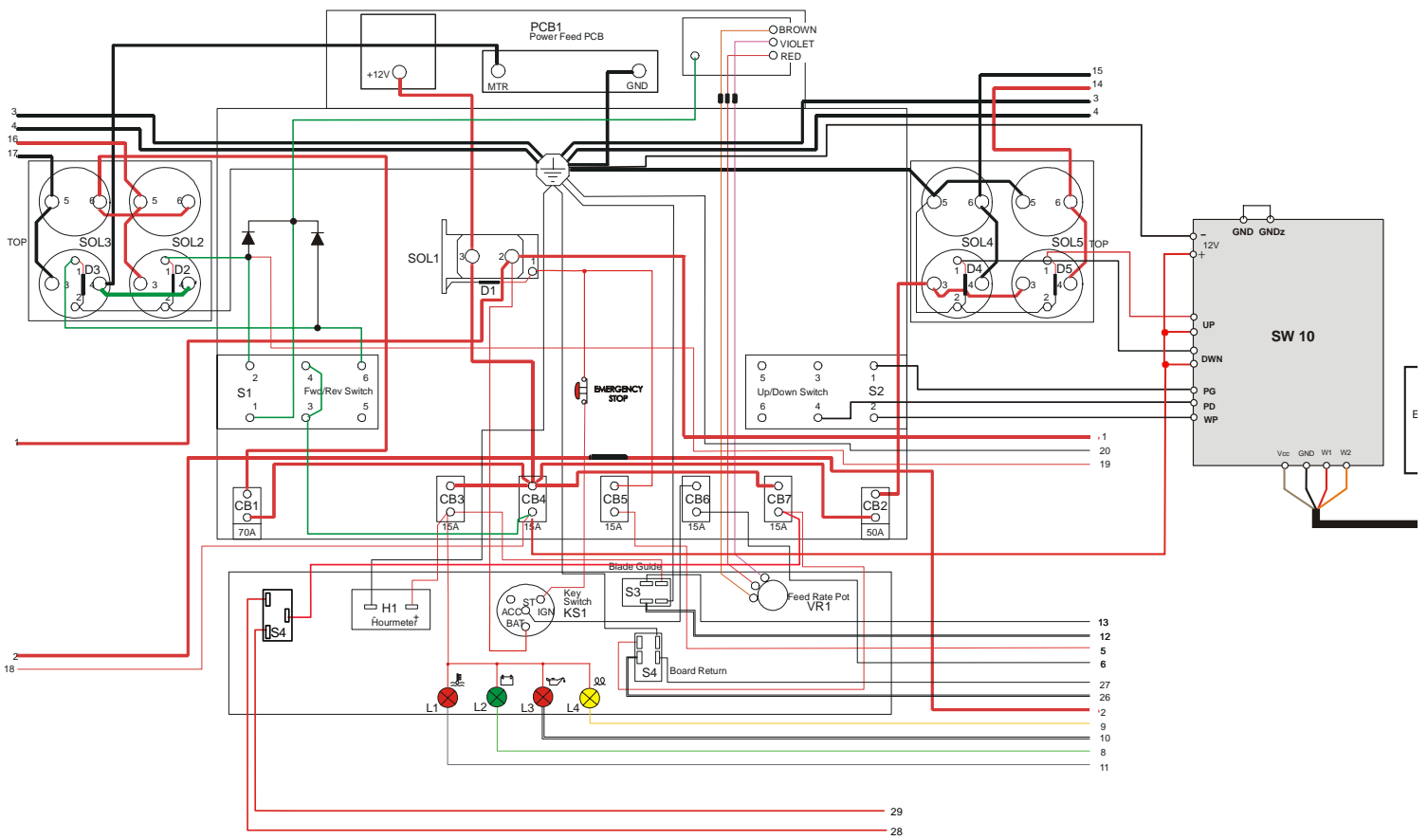

**4.3 Electrical Components, G28 LT40 Non-hydraulic**

Item	Mfg. Part No.	Manufacturer	WM Part #	Description
A1	CS-130	Delco-Remy	050287	Alternator, 12 Volt, 105 A
B1	#95601	BANNER	088322	Battery, 12 V
CB1	30128-30	Cole-Hersee	E20486	Circuit Breaker, 30 Amp, 12 Volt, For Power Feed Motor, Auto Reset
F1	RL-150	Gould	023361	Fuse Link, 150 Amp, 250 Volt For Main + 12 Volt Starter, Alternator
H1	T14BH517BC9	ENM Corp.	015401	Hour Meter, 12 Volt, Low Power T14 Series
KS1	121801	General	P04350	Key Switch, 4-position (Accessory, Off, Ignition, Start)
M1	PR4R0009Q	Owosso	014359	Motor, 12 Volt Power Feed
M2	PR-4P07Q	Owosso	A07974	Motor, 12 Volt Up/Down
M3	P09698-1	Klauber	A10365	Motor, 12 Volt Blade Guide Arm 53:1 Gear
PCB1	015410	Wood-Mizer	015410	Circuit Board, Control Box
PCB2	015416	Wood-Mizer	015416	Circuit Board, LED Circuit (Gas/Elec)
S1	2601-AF2-S11	Square D	E20439	Drum Switch, (U.S.), Power Feed Fwd/Reverse Motor
S2	2601-AF2-S12	Square D	E20440	Drum Switch, Up/Down Motor
S3	34-591Q	Pollak	024200	Toggle Switch, Blade Guide In/Out Motor
PK1	-	-	092284	Relay, Safety Key Switches
P1	XB4BS542	Schneider	086556	Switch, Emergency Stop

**TABELA 4-1**



### 4.4 Electrical Components, G28 LT40 Hydraulic

Item	Mfg. Part No.	Manufacturer	WM Part #	Description
A1	CS-130	Delco-Remy	050287	Alternator, 12 Volt, 105 A
B1	#95601	BANNER	088322	Battery, 12 V
CB1	30128-30	Cole-Hersee	E20486	Circuit Breaker, 30 Amp, 12 Volt, For Power Feed Motor, Auto Reset
F1	RL-150	Gould	023361	Fuse Link, 150 Amp, 250 Volt For Main + 12 Volt Starter, Alternator
F2	RL-225	Gould	P11550	Fuse Link, 225 Amp, 250 Volt For Hydraulic +12 Volt Circuit
H1	T14BH517BC9	ENM Corp.	015401	Hour Meter, 12 Volt, Low Power T14 Series
KS1	121801	General	P04350	Key Switch, 4-position (Accessory, Off, Ignition, Start)
M1	PR4R0009Q	Owosso	014359	Motor, 12 Volt Power Feed
M2	PR-4P07Q	Owosso	A07974	Motor, 12 Volt Up/Down
M3	P09698-1	Klauber	A10365	Motor, 12 Volt Blade Guide Arm 53:1 Gear
M4	8111	Monarch Hyd.	P09955	Motor, 12 Volt Hydraulic Pump
PCB1	015410	Wood-Mizer	015410	Circuit Board, Control Box Power Feed
PCB2	015416	Wood-Mizer	015416	Circuit Board, LED Circuit (Gas/Elec)
S1	2601-AF2-S11	Square D	E20439	Drum Switch, (U.S.), Power Feed Fwd/Reverse Motor
S2	2601-AF2-S12	Square D	E20440	Drum Switch, Up/Down Motor
S3	34-591Q	Pollak	024200	Toggle Switch, Blade Guide In/Out Motor
S4	024198	Wood-Mizer	024198	Switch, Hydraulic Pump Levers
SOL1	586-902	Stancor	015470	Solenoid, 200A 12V SPST Hydraulic Pump Motor
PK1	-	-	092284	Relay, Safety Key Switches
P1	XB4BS542	Schneider	086556	Switch, Emergency Stop

TABELA 4-2