

# **G25 Engine**

## **Safety, Operation, Maintenance & Parts Manual**

---

**LT20 Series**

**rev. D5.00**

---



**Safety is our #1 concern!** Read and understand all safety information and instructions before operating, setting up or maintaining this machine.

*June 2007*

*Form #826*

## Table of Contents

## Section-Page

<b>SECTION 1</b>	<b>OPERATION</b>	<b>1-1</b>
1.1	Starting The Engine .....	1-1
<b>SECTION 2</b>	<b>MAINTENANCE</b>	<b>2-1</b>
2.1	Safety .....	2-1
2.2	Cooling System .....	2-2
2.3	Air Filter & Pre-Cleaner .....	2-2
2.4	Engine Oil & Filter .....	2-3
2.5	Fuel Filter .....	2-3
2.6	Battery .....	2-4
2.7	Alternator Belt .....	2-5
2.8	RPM Adjustments .....	2-6
2.9	Miscellaneous Maintenance .....	2-7
<b>SECTION 3</b>	<b>REPLACEMENT PARTS</b>	<b>3-1</b>
3.1	How To Use The Parts List .....	3-1
3.2	Sample Assembly .....	3-1
3.3	Fuel Tank Assembly .....	3-2
3.4	Engine Mount Assembly .....	3-4
3.5	Engine Assembly .....	3-5
3.6	Muffler Assembly .....	3-6
3.7	Drive Assembly .....	3-7
3.8	Throttle Cable Assembly .....	3-8
3.9	Alternator Assembly .....	3-9
3.10	Relay & Plate Assembly .....	3-10
<b>SECTION 4</b>	<b>ELECTRICAL INFORMATION</b>	<b>4-1</b>
4.1	Electrical Wiring Diagram G25, D22 Engines .....	4-1
4.2	Electrical Components G25-20S, DP22-20S .....	4-3

## ABOUT THIS MANUAL

This manual is provided as a supplement to the equipment manufacturer's manuals. This manual provides information specific to the use of this equipment on the Wood-Mizer® sawmill. Refer to the sawmill operator's manual and manufacturer's manual before attempting to operate this equipment.



**IMPORTANT!** Read the sawmill operator's manual and engine manufacturer's manual for instructions and safety precautions before operating this equipment.

The information and instructions given in this manual do not amend or extend the limited warranties for the equipment given at the time of purchase.

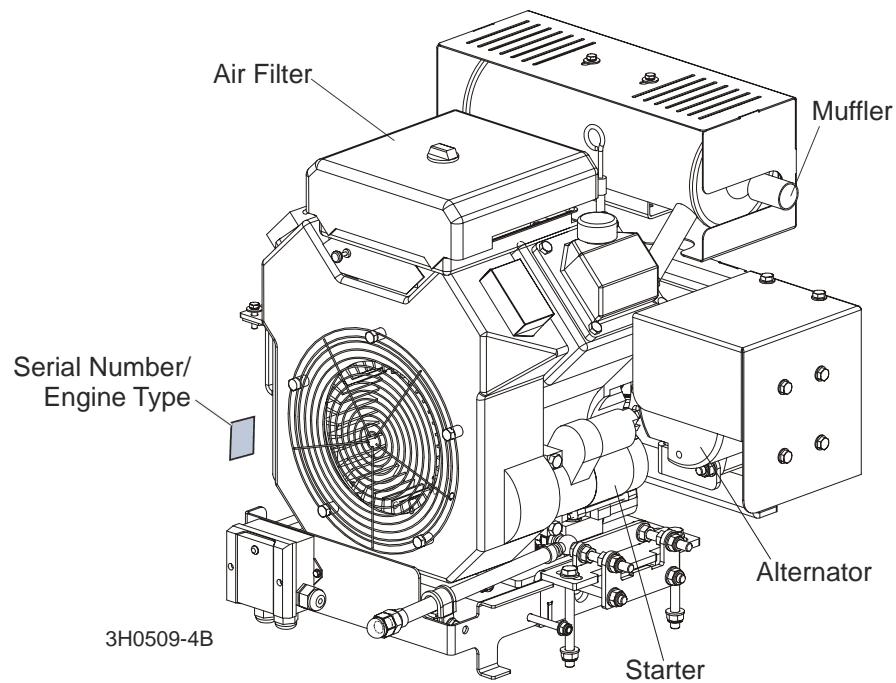

### **ENGINE COMPONENTS**

## SECTION 1 OPERATION

### 1.1 Starting The Engine

#### Engine Control Lights

See **Figure 1-1**. The following indicator lights are located on the sawmill control panel.



*Alternator Charge Indicator:* Lights up if the alternator is not charging the battery.



*Engine Temperature Indicator:* Lights up if the engine is overheating. A circuit breaker assembly in the engine harness will shut the engine off if the engine overheats. Turn the key switch off and allow the engine to cool for a period of time before restarting. If the overheating condition persists, stop operating the engine until the condition is corrected. The engine will automatically switch to low idle if an overheating condition occurs.



*Oil Indicator:* Lights up if the oil pressure is too low.

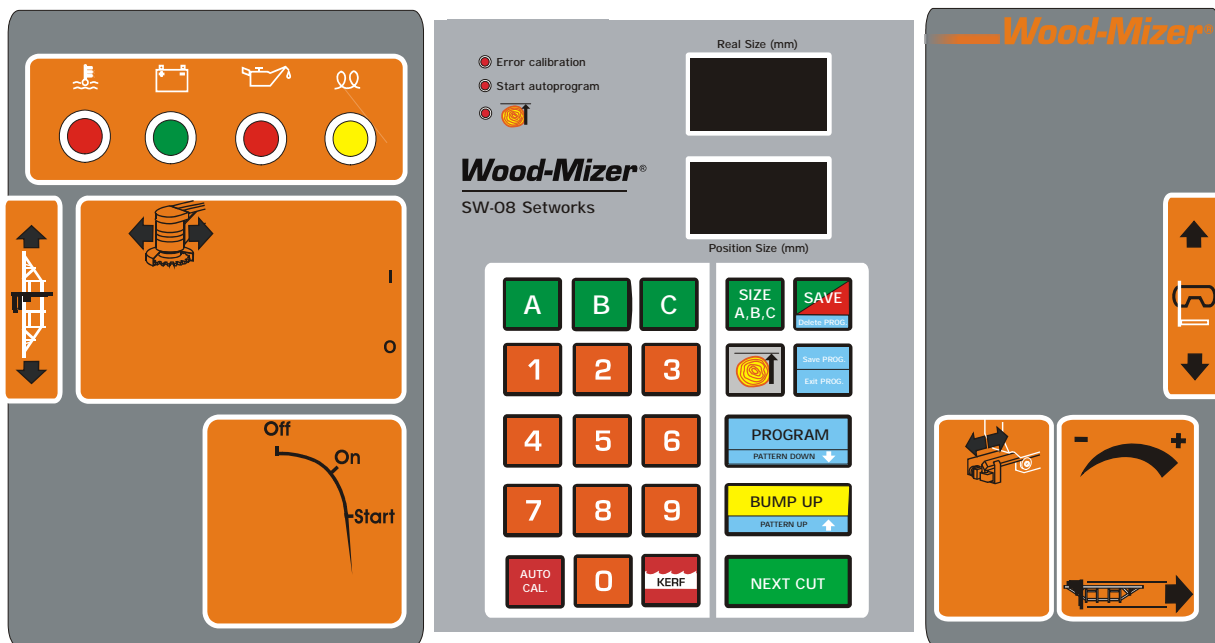

FIG. 1-1

## Engine Start



**DANGER!** Always be sure the blade is disengaged and all persons are out of the path of the blade before starting the engine. Failure to do so will result in serious injury.

**DANGER!** Operate your engine/machine only in well ventilated areas. The exhaust gases of your engine can cause nausea, delirium and potentially death unless adequate ventilation is present.

**DANGER!** Never operate an engine with a fuel or oil leak. The leaking fuel or oil could potentially come in contact with hot surfaces and ignite into flames.



**WARNING!** Be sure the power feed switch is in the neutral position before turning the key switch to the on (#1) position. This prevents accidental carriage movement, which may cause serious injury or death.

**WARNING!** Do not operate engine without proper and operational spark arrester/muffler. Sparks emitted from the engine exhaust could ignite surrounding materials, causing serious injury or death.

Turn the key switch to the start (#2) position and release.

If the engine needs choking to start, pull the choke cable out until the engine starts. Push the choke wire in after the engine starts.

For more information, see the engine manufacturer's operation manual.

If the fuel tank was recently filled or replaced, squeeze the primer bulb once or twice before trying to start the engine. **NOTE:** If pumping problems are experienced, make sure the out-flow end of the hose line is connected to the fuel filter. If pumping problems are still experienced, hold the primer bulb in a vertical position while squeezing. This allows the fuel check valve to operate properly.

**NOTE:** When the clutch handle is engaged, an accelerator pump is activated which supplies fuel to the engine carburetor. To avoid flooding the carburetor and possibly fouling the spark plugs, do not engage the clutch lever repeatedly without the engine running.

# **1** **Operation**

## *Starting The Engine*

---

### **Engine Shutoff**

Turn the key switch to the off (#0) position.

## SECTION 2 MAINTENANCE

Refer to the manufacturer's manual for maintenance intervals and procedures unless otherwise instructed in this manual. Follow the manufacturer's recommendations for dusty conditions.



**IMPORTANT!** This manual only provides information about additional procedures or procedures to be performed at different time intervals than found in the manufacturer's manuals. Refer to the manufacturer's manual for complete maintenance instructions.

### 2.1 Safety

Use caution when performing maintenance or service to the engine.



**DANGER!** Always be aware of and take proper protective measures against rotating shafts, pulleys, fans, etc. Always stay a safe distance from rotating members and make sure that loose clothing or long hair does not engage rotating members resulting in possible injury.

**DANGER!** Engine components can become very hot during operation. Avoid contact with any part of a hot engine. The exhaust components of your engine are especially hot during and following operation. Contact with hot engine components can cause serious burns. Therefore, never touch or perform service functions on a hot engine. Allow the engine to cool sufficiently before beginning any service function.



**WARNING!** Remove the blade before performing any engine service. Failure to do so may result in serious injury.

**WARNING!** Always wear proper and necessary safety equipment when performing service functions. Proper safety equipment includes eye protection, breathing protection, hand protection and foot protection.



**This symbol** identifies the interval (hours of operation) at which each maintenance procedure should be performed. "AR" signifies maintenance procedures which should be performed as required.





## 2.2 Cooling System

-  Wash the engine or brush off sawdust and debris every 50 hours of operation. Clean the grass screen, cooling fins, and external surfaces. Remove any dust, dirt or oil. See engine manual for further instructions.

## 2.3 Air Filter & Pre-Cleaner



**WARNING!** Always wear proper and necessary safety equipment when performing service functions. Proper safety equipment includes eye protection, breathing protection, hand protection and foot protection.

-  Service the pre-cleaner every four hours of operation. Service by gently shaking excess sawdust and debris from the foam piece.
-  Clean the air filter (air cleaner element) and pre-cleaner (element wrapper) every eight hours of operation. See the engine manual for further instructions.
-  Replace the air filter (cleaner) every 200 hours of operation.
-  Replace the pre-cleaner (element wrapper) every 2000 hours of operation.



## 2.4 Engine Oil & Filter



Check the oil level every 8 hours of operation. Add oil as necessary. See the engine manual for oil viscosity and grade recommendations.



**IMPORTANT!** During initial break-in, change the oil and the oil filter after the first 5 hours and every 50 hours thereafter. Continue to check oil level every 8 hours of operation and refill as necessary.



**NOTE:** Engine in factory is filled with 5W/40 Shell Helix Ultra, full synthetic oil.

## 2.5 Fuel Filter



**IMPORTANT!** For best results use only clean, fresh, **unleaded** gasoline with a pump sticker octane rating of 87 or higher. In countries using the Research method, it should be 90 octane minimum.



Replace the fuel filter every 100 hours of operation.

## 2.6 Battery



Check the battery electrolyte level every 50 hours of operation. See manufacturer's manual for instructions.



**DANGER!** Batteries expel explosive gases. Keep sparks, flames, burning cigarettes, or other ignition sources away at all times. Always wear safety goggles and a face shield when working near batteries. Failure to do so will cause serious injury.<sup>1</sup>



**WARNING!** Battery posts, terminals and related accessories contain lead and lead compounds, chemicals. Wash hands after handling.

---

1. Battery Council International, copyright 1987

## 2.7 Alternator Belt



Adjust the alternator belt as needed. Check the alternator belt for tension and wear when battery is not charging properly or when the alternator belt is squealing. To tighten the belt, loosen the adjustment bolt and lock washer. Pivot the alternator away from the motor until the belt has 10.5 mm deflection with a 3.0 kG deflection force. Retighten the adjustment bolt.

See Figure 2-1.

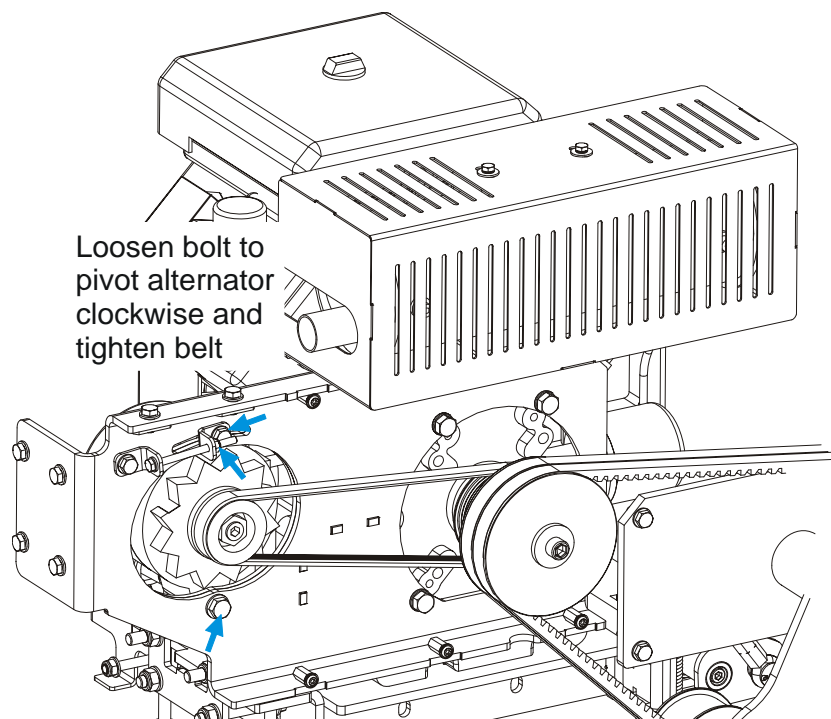

FIG. 2-1

## 2.8 RPM Adjustments



**WARNING!** Remove the blade before performing any engine service. Failure to do so may result in serious injury.

200

Check the RPM with a tachometer after the first 20 hours of operation and every 200 hours thereafter. High-end RPM should be 3750 RPM and low-end RPM should be 1800 RPM ( $\pm 100$ ).

Before checking the RPM, make sure belt and brake strap tensions are correct (See Saw-mill Maintenance). Also check oil and fuel levels.

Make sure the throttle cable does not affect the engine RPM when the clutch handle is disengaged. Make sure the cable is not bent or kinked. Check that the cable spring, cable guide, cable, and throttle brackets are aligned. **NOTE:** It is important that the above components are aligned. Proper alignment allows any slack in the cable (when engine is idling) to slide down into the cable spring. This maintains free operation of the cable and prevents the cable from kinking.

1. Start the engine to measure the low-end RPM.
2. Refer to the engine manual to adjust the low-end RPM.
3. Engage the clutch handle to throttle the engine and measure the high-end RPM. The high-end RPM is factory-set at 3750. Readjust the throttle cable if necessary to increase or reduce the high-end engine speed.

The throttle cable should be tensioned just enough so that the engine revs as soon as the clutch/brake handle is engaged. **NOTE:** A properly adjusted throttle will extend the cable spring 1/4" to 3/8" (6.4 - 9.5 mm) when running and have a slight amount of slack in the cable when idling.

## 2.9 Miscellaneous Maintenance



Inspect the spark plugs every 100 hours of operation. Remove any deposits and adjust gap if necessary. See engine manual for further information.



**CAUTION!** Do not remove the plug wire to check for electrical spark. Damage to the ignition circuit will result.

## SECTION 3 REPLACEMENT PARTS

### 3.1 How To Use The Parts List

- Use the table of contents or the index to locate the assembly that contains the part you need.
- Go to the appropriate section and locate the part in the illustration.
- Use the number pointing to the part to locate the correct part number and description in the table.
- Parts shown indented under another part are included with that part.
- Parts marked with a diamond (◆) are only available in the assembly listed above the part.

See the sample table below. Sample Part #A01111 includes part F02222-2 and subassembly A03333. Subassembly A03333 includes part S04444-4 and subassembly K05555. The diamond (◆) indicates that S04444-4 is not available except in subassembly A03333. Subassembly K05555 includes parts M06666 and F07777-77. The diamond (◆) indicates M06666 is not available except in subassembly K05555.

<b>3.2 Sample Assembly</b>				
REF	DESCRIPTION (◆ Indicates Parts Available In Assemblies Only)	PART #	QTY.	
	<b>SAMPLE ASSEMBLY, COMPLETE (INCLUDES ALL INDENTED PARTS BELOW)</b>	A01111	1	
1	Sample Part	F02222-22	1	
	Sample Subassembly (Includes All Indented Parts Below)	A03333	1	
2	Sample Part (◆ Indicates Part Is Only Available With A03333)	S04444-4	1	◆
	Sample Subassembly (Includes All Indented Parts Below)	K05555	1	
3	Sample Part (◆ Indicates Part Is Only Available With K05555)	M06666	2	◆
4	Sample Part	F07777-77	1	

#### To Order Parts:

- From the continental U.S., call our toll-free Parts hotline at **1-800-448-7881**. From Europe call our European Headquarters and Manufacturing Facility in Kolo, Poland at **+48-63-2626000** or **+48-3912-1319**. Have your customer number, vehicle identification number, and part numbers ready when you call.
- From other international locations, contact the Wood-Mizer distributor in your area for parts.

### 3.3 Fuel Tank Assembly

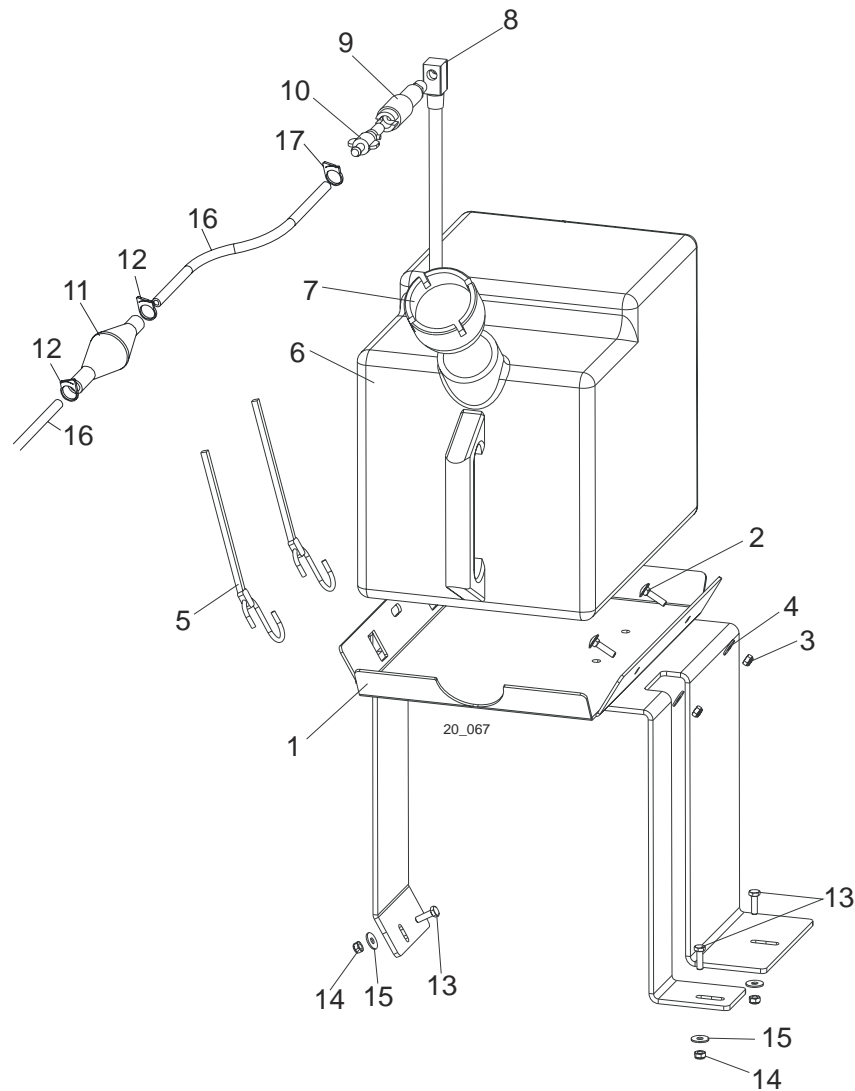

REF	DESCRIPTION (◆ Indicates Parts Available In Assemblies Only)	PART #	QTY.	
	<b>TANK ASSEMBLY, LT20 SERIES FUEL</b>	092279	1	
1	Tray, LT20 Series Fuel Tank	091885-1	1	
2	Bolt, M6x25-8.8 Carriage Head Zinc	F81001-20	2	
3	Nut, M6-8-B Hex Nylon Zinc Lock	F81031-2	2	
4	Washer, 6.5 Zinc Flat Special	F81053-11	2	
5	Strap, 24" Fuel Tank Rubber	P11258	2	
6	Tank, 5-Gallon Red Fuel	P12167	1	
7	Cap, 3 or 5-Gallon Fuel Tank	P09683	1	
8	Pickup, Fuel	P12172	2	
9	Fitting, 1/4" Plastic Male-Female Disconnect	P12175	1	
10	Fitting, 1/4 Barb Male Disconnect	P12176	1	
11	Bulb, Fuel Primer	014481	1	◆
12	Clamp, 1/2" OD Fuel Hose	P12374	2	

**3****Replacement Parts***Fuel Tank Assembly*

---

13	<b>BOLT, M6X20-8.8 HEX HEAD FULL THREAD ZINC</b>	F81001-2	3	
14	<b>NUT, M6-8-B HEX NYLON ZINC LOCK</b>	F81031-2	3	
15	<b>WASHER, 6.5 ZINC FLAT SPECIAL</b>	F81053-11	3	
16	<b>HOSE, 1/4" ID FUEL</b>	R01890-1	2 m	
17	<b>CLAMP, 1/2" OD FUEL HOSE</b>	P12374	1	



3.4 Engine Mount Assembly

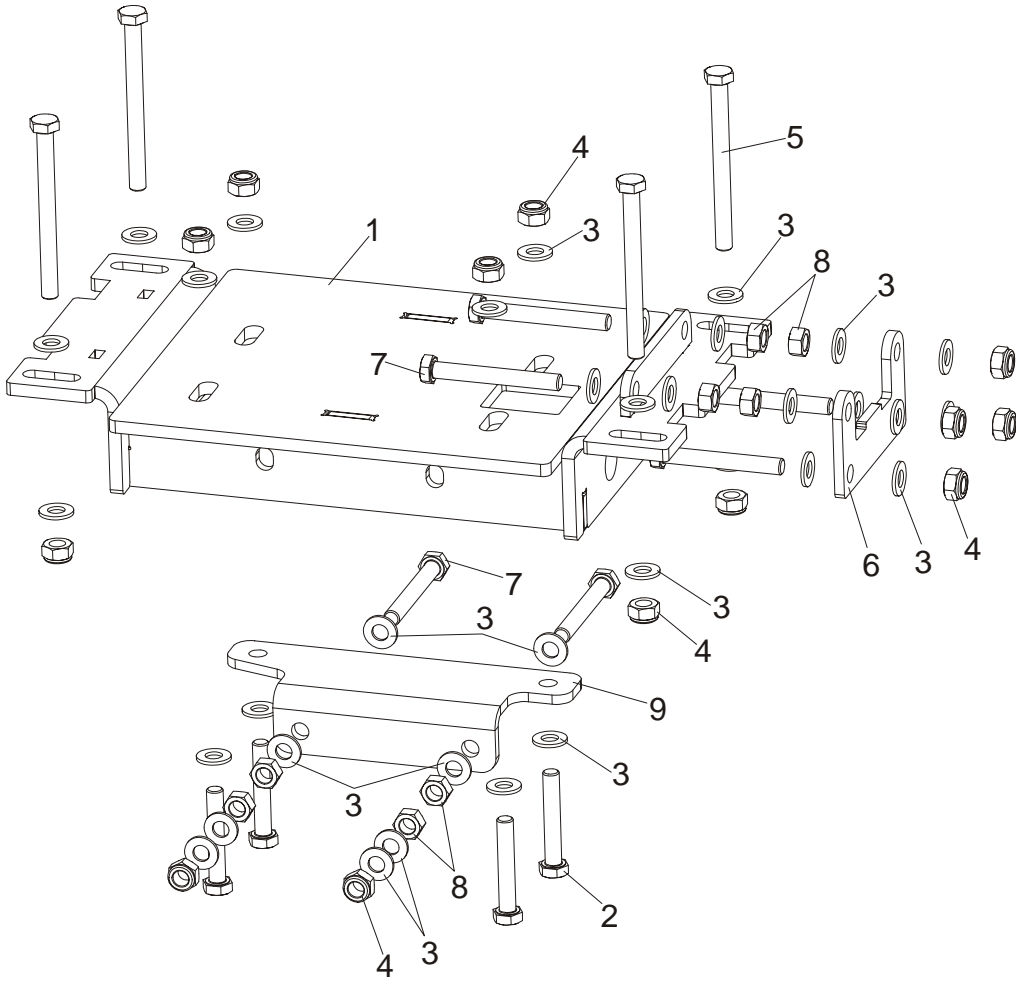

REF	DESCRIPTION (◆ Indicates Parts Available In Assemblies Only)	PART #	QTY.
1	MOUNT, G18 ENGINE	092250-1	1
2	BOLT, M10X60-8.8 HEX HEAD ZINC	F81003-10	4
3	WASHER, 10.5 ZINC FLAT	F81055-1	34
4	NUT, M10-8-B HEX NYLON ZINC LOCK	F81033-1	14
5	BOLT, M10X110 8.8 HEX HEAD ZINC	F81003-43	4
6	PLATE, BELT TENSIONER	097821-1	1
7	BOLT, M10X80-8.8 HEX HEAD ZINC	F81003-76	4
8	NUT, M10-8-B ZINC	F81033-3	8
9	ENGL, ENGINE MOUNT	097827-1	1

### 3.5 Engine Assembly

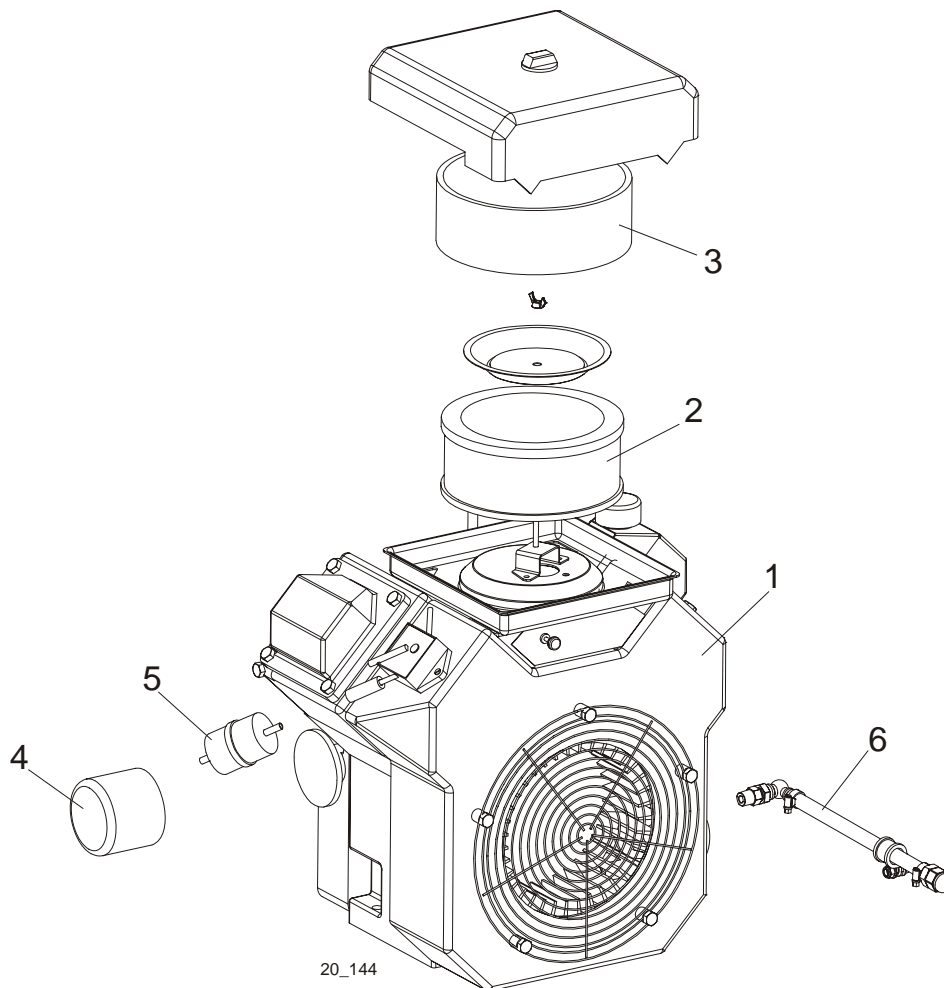

REF	DESCRIPTION (◆ Indicates Parts Available In Assemblies Only)	PART #	QTY.	
1	<b>ENGINE KIT, KOHLER 25HP BASIC</b>	097810	1	◆
2	Filter, Kohler Air	092347	1	
3	Pre Cleaner, Kohler	092348	1	
	Plug, RC12YC Kohler Spark	P12757	2	
4	Filter, Kohler Oil	092349	1	
5	Filter, Kohler Fuel	092350	1	
6	<b>HOSE, G25 KOHLER ENGINE OIL DRAIN COMPLETE</b>	097823	1	
7	<b>STARTER, G25 KOHLER</b>	098894	1	
8	<b>SWITCH, G25 KOHLER STARTING</b>	098895	1	
9	<b>CARBURATOR, G25 KOHLER</b>	098896	1	
10	<b>IGNITION COIL &amp; HIGH VOLTAGE WIRES, G25 KOHLER</b>	084615	1	
11	<b>PUMP, G25 KOHLER FUEL</b>	084617	1	

### 3.6 Muffler Assembly

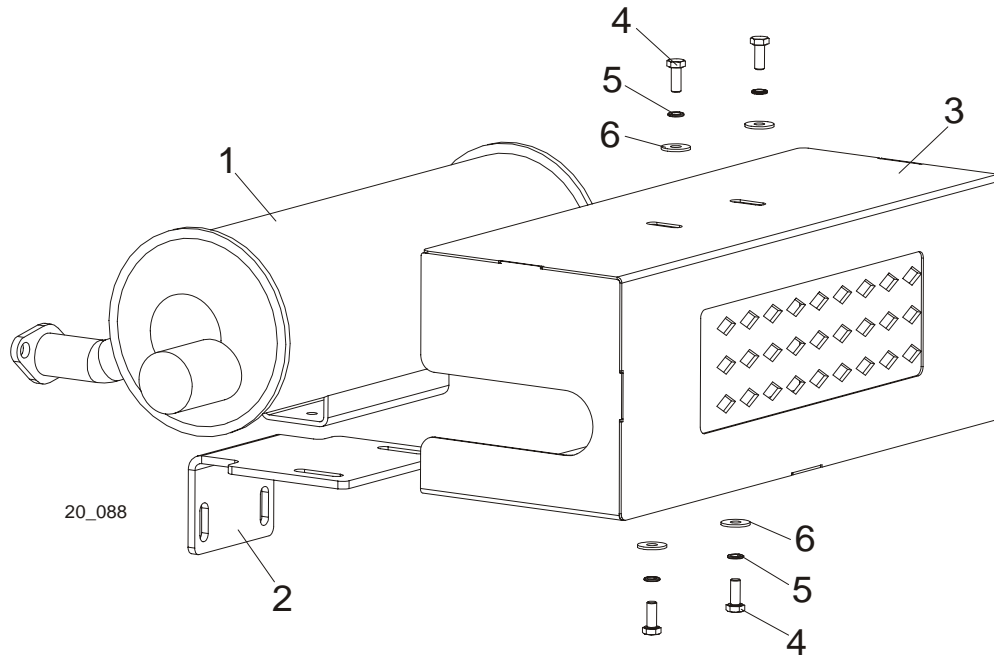

REF	DESCRIPTION (◆ Indicates Parts Available In Assemblies Only)	PART #	QTY.	
1	MUFFLER, 24068 37-S COMMAND 18	092278	1	
2	BRACKET, G18 MUFFLER MOUNT	092501-1	1	
3	GUARD, GP25/GP18 MUFFLER COMPLETE	091859-1	1	
4	BOLT, M6X16 8.8 HEX HEAD FULL THREAD ZINC	F81001-15	4	
5	WASHER, Z 6.1 SPLIT LOCK ZINC	F81053-3	4	
6	WASHER, 6.5 ZINC FLAT SPECIAL	F81053-11	4	

### 3.7 Drive Assembly

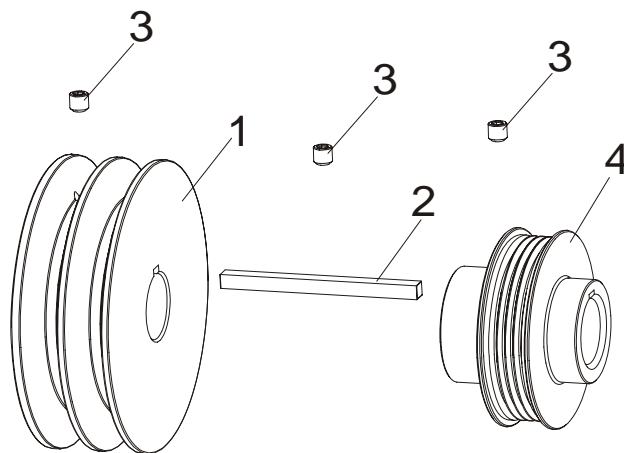

20\_143

REF	DESCRIPTION (◆ Indicates Parts Available In Assemblies Only)	PART #	QTY.	
1	PULLEY, ENGINE OXIDE	092253-1	1	
2	KEY, B6,35X6,35X85 ZINC	097822	1	
3	SCREW, M8X8-33H FLAT POINT HEX SOCKET SET ZINC	F81014-1	3	
4	PULLEY, 105A ALTERNATOR ZINC	097814-1	1	
	V-BELT, BX83 1/2	088110	2	

### 3.8 Throttle Cable Assembly

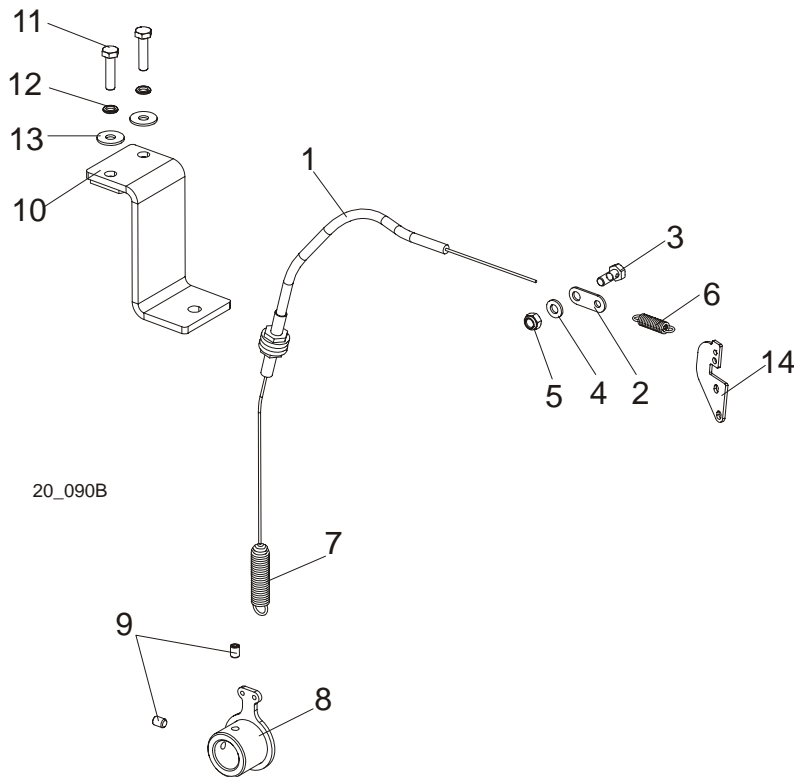

REF	DESCRIPTION (◆ Indicates Parts Available In Assemblies Only)	PART #	QTY.
	<b>CABLE, G18 THROTTLE COMPLETE</b>	092550	1
1	Cable, G18 Throttle	092259	1
2	Plate, G18 Throttle Cable Spring Mount Zinc	092531-1	1
3	Bolt, Throttle Cable Clamp Zinc	088120-1	1
4	Washer, 6.4 Flat Zinc	F81053-1	1
5	Nut, M6-8-B Hex Nylon Zinc Lock	F81031-2	1
6	Spring, 1.3 x 8 x 20 Extension	092549	1
7	Spring, 35 x 9,5 x 1,6 Special	<b>097443</b>	1
8	<b>BRACKET, G18 THROTTLE/TENSIONER HANDLE</b>	092535-1	1
9	<b>SCREW, M6X8 CONE POINT HEX SOCKET SET ZINC</b>	F81013-1	2
10	<b>BRACKET, G18 THROTTLE CABLE MOUNT</b>	092532-1	1
11	<b>BOLT, M6X25-5.8 HEX HEAD FULL THREAD ZINC</b>	F81001-3	2
12	<b>WASHER, Z 6.1 SPLIT LOCK ZINC</b>	F81053-3	2
13	<b>WASHER, 6.5 ZINC FLAT SPECIAL</b>	F81053-11	2
14	<b>BRACKET, G25 THROTTLE</b>	091565-1	1

### 3.9 Alternator Assembly

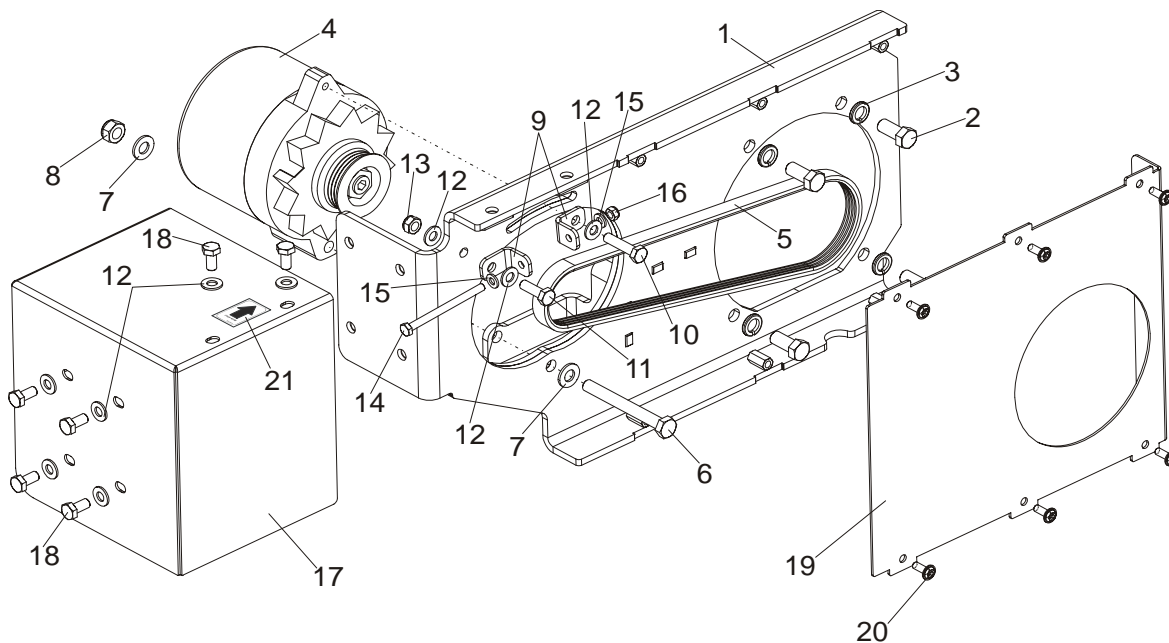

REF	DESCRIPTION (◆ Indicates Parts Available In Assemblies Only)	PART #	QTY.
1	BRACKET, LT20G25 ALTERNATOR MOUNT	097811-1	1
2	BOLT, UNC 7/16-14X1 8,8 DIN933 BM67	F05007-145	4
3	WASHER, M12 SPLIT LOCK ZINC	F81056-2	4
4	ALTERNATOR, 105A 12V CS130	050287	1
5	BELT, 4PK755 ALTERNATOR (GOOD-YEAR)	097815	1
6	BOLT, M10X90 -8.8-B- FE/ZN5 PN/M-82101	F81003-66	1
7	WASHER, 10.5 ZINC FLAT	F81055-1	2
8	NUT, M10 NYLON HEX ZINC LOCK	F81033-1	1
9	TENSIONER, 30A ALTERNATOR BELT	095296-1	2
10	BOLT, 8MM X 1.25X35MM HH ZINC	F81002-13	1
11	BOLT, M8 X 25MM HEX HEAD GR 5.8 ZINC	F81002-5	1
12	WASHER, M8 FLAT ZINC	F81054-1	9
13	NUT, M8 HEXAGON NYLON LOCK ZINC	F81032-2	1
14	BOLT, M6X80 HH ZINC	F81001-61	1
15	WASHER, M6 FLAT ZINC	F81053-1	2
16	NUT, M6 HEX NYLON LOCK ZINC	F81031-2	1
17	GUARD, 105A 12V CS130 ALTERNATOR	097819-1	1
18	BOLT, M8X16-8.8-B HH ZINC	F81002-20	6
19	GUARD, ALTERNATOR BELT	097816-1	1
20	BOLT, M6X16 BN 11252 "BOSSARD"	F81001-24	6
21	DECAL, 3600 RPM ENGINE ROTATION DIRECTION	S20097A	1

3.10 Relay & Plate Assembly

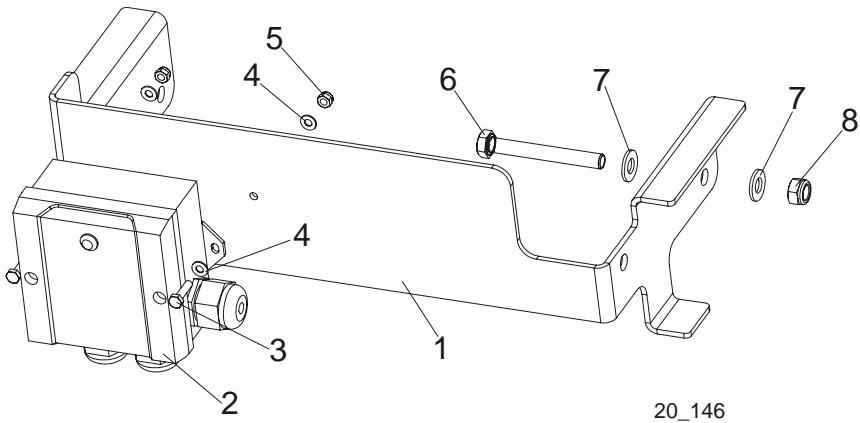

20\_146

REF	DESCRIPTION (◆ Indicates Parts Available In Assemblies Only)	PART #	QTY.
	<b>RELAY &amp; PLATE ASSY, COMPLETE</b>	<b>097841</b>	1
1	Plate, Relay	097840-1	1
2	Relay, G18/25	092284	1
3	Bolt, M4x16 5.8 HH Zinc	F81011-6	2
4	Washer, 4.3 Zinc	F81051-2	4
5	Nut, M4-B Zinc	F81029-1	2
6	Bolt, M8x65 8.8 HH Zinc	F81002-9	1
7	Washer, 8.4 Zinc	F81054-1	2
8	Nut, M8-8-B Zinc	F81032-2	1

## **SECTION 4 ELECTRICAL INFORMATION**

### **4.1 Electrical Wiring Diagram G25, D22 Engines**



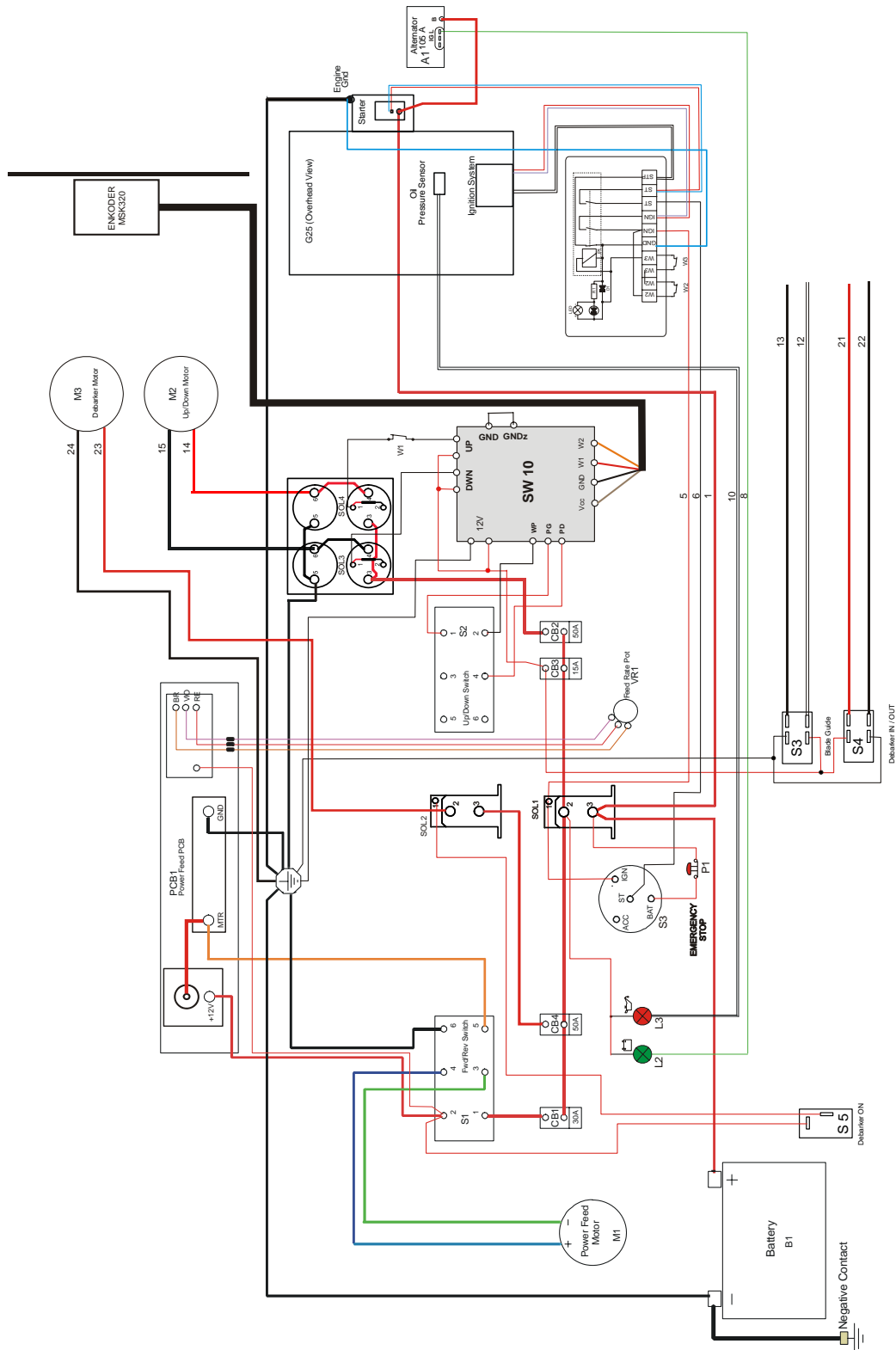

FIG. 4-0 G25, D22 ELECTRICAL WIRING DIAGRAM

## 4.2 Electrical Components G25-20S, DP22-20S

Item	Manufacturer	WM Part #	Description
S1	SCHNEIDER ELECTRIC	E20439	Switch, US1992 Pwr/Feed (Service Package)
S2	SCHNEIDER ELECTRIC	E20438	Switch, 1992GS Pwr/Feed (Service Package)
B1	BANNER	090999	Battery, 12V 50Ah ENERGY BULL BA50
CB1	-	024246	Breaker, 30 Amp Manual Reset Panel Mount
CB2	-	021256	Breaker, 50 Amp Manual Reset Panel Mount
PCB1	WMP	024396-1	Module, Power Feed Control
S3	-	P04350	Key Switch
SOL1	-	P10449	Solenoid, 120-943 12V DC
SOL2	KUBOTA	-	Solenoid, Engine Shut-Off (diesel)
PK1	-	086486	Relay, Safety Key Switches
VR1	-	E20519	Potentiometer, 1K Feed Rate
M1,M2	-	P04140	Motor, 12V 0.5HP Up/Down
P1	SCHNEIDER ELECTRIC	086556	Switch, XB4 BS542 Emergency Stop
L1, L3	-	090998	Control Light, KLA-RS-10-2
L2	-	091051	Control Light, KLA-GS-10-2
L4	-	091456	Control Light, KLA-RS-10-2
W2	HONEYWELL	087650	Limit Switch, GKMC03W2
W3	HONEYWELL	091742	Limit Switch, EVN2000A (Saw Head Loading Position)
W1	HONEYWELL	089816	Limit Switch, EVN2000C (Maximum Saw Head Height)
R1	BOSCH	088143	Relay, #191911261C Glow Plug (diesel)

TABLE 4-1

