

G25 Engine

Safety, Operation, Maintenance & Parts Manual

LT40 Series

rev. E2.00



Safety is our #1 concern! Read and understand all safety information and instructions before operating, setting up or maintaining this machine.

September 2003

Form #825

Table of Contents

Section-Page

SECTION 1 OPERATION

1-1

1.1 Starting The Engine1-1

SECTION 2 MAINTENANCE

2-1

2.1 Safety2-1

2.2 Cooling System2-2

2.3 Air Filter & Pre-Cleaner2-2

2.4 Fuel Filter2-2

2.5 Battery2-3

2.6 Alternator Belt2-4

2.7 RPM Adjustments2-5

2.8 Miscellaneous Maintenance2-6

SECTION 3 REPLACEMENT PARTS

3-1

3.1 Fuel Tank Assembly3-1

3.2 Engine Mount Assembly3-2

3.3 Engine Assembly3-3

3.4 Alternator Assembly3-5

3.5 Engine Pulley Guards3-7

SECTION 4 ELECTRICAL INFORMATION

4-1

4.1 Electrical Symbol Diagram, G25 LT40 Series4-1

4.2 Electrical Symbol Diagram, LT40 Series4-2

4.3 Electrical Components, G25 LT40 non-hydraulic4-3

4.4 Electrical Components, G25 LT40 hydraulic4-4

ABOUT THIS MANUAL

This manual is provided as a supplement to the equipment manufacturer's manuals. This manual provides information specific to the use of this equipment on the Wood-Mizer® sawmill. Refer to the sawmill operator's manual and manufacturer's manual before attempting to operate this equipment.



IMPORTANT! Read the sawmill operator's manual and engine manufacturer's manual for instructions and safety precautions before operating this equipment.

The information and instructions given in this manual do not amend or extend the limited warranties for the equipment given at the time of purchase.

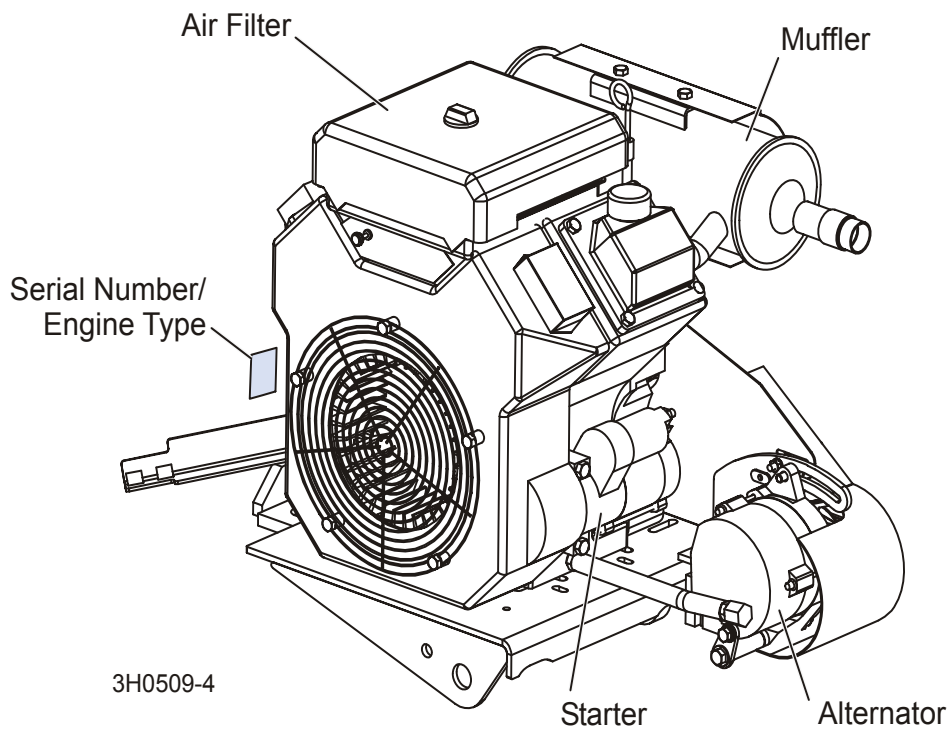

ENGINE COMPONENTS

SECTION 1 OPERATION

1.1 Starting The Engine

Engine Control Lights

See Figure 1-1. The following indicator lights are located on the sawmill control panel.



Alternator Charge Indicator: Lights up if the alternator is not charging the battery.



Engine Temperature Indicator: Lights up if the engine is overheating. A circuit breaker assembly in the engine harness will shut the engine off if the engine overheats. Turn the key switch off and allow the engine to cool for a period of time before restarting. If the overheating condition persists, stop operating the engine until the condition is corrected. The engine will automatically switch to low idle if an overheating condition occurs.



Oil Indicator: Lights up if the oil pressure is too low.

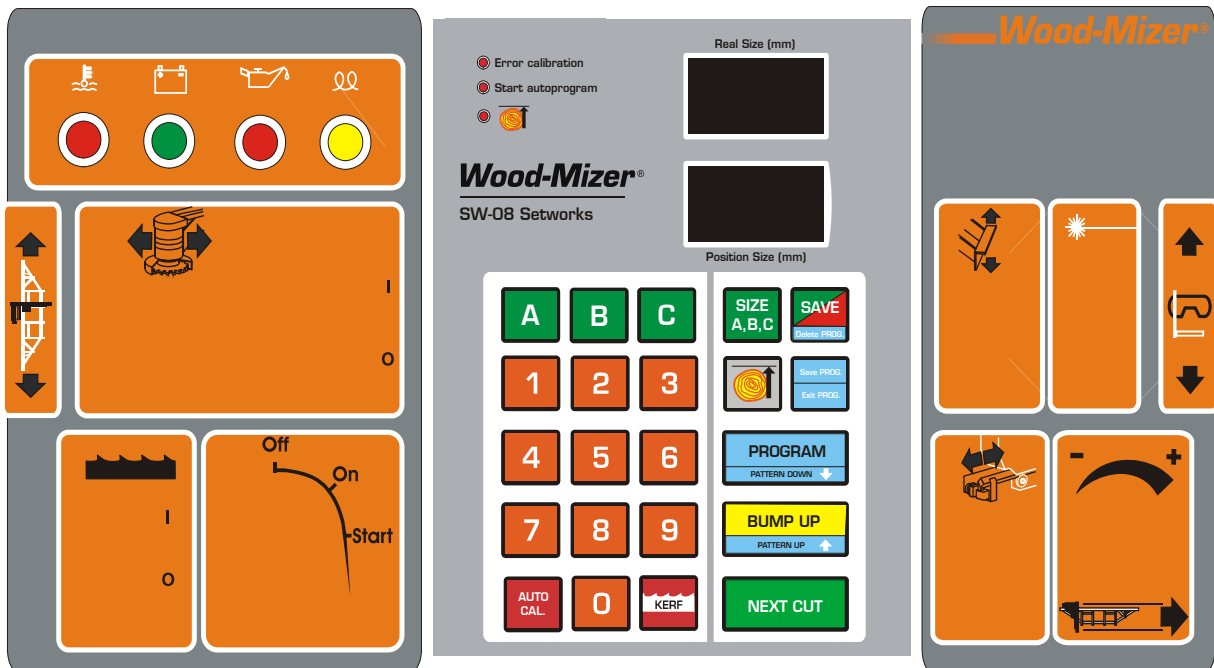

FIG. 1-1

Engine Start



DANGER! Always be sure the blade is disengaged and all persons are out of the path of the blade before starting the engine. Failure to do so will result in serious injury.

DANGER! Operate your engine/machine only in well ventilated areas. The exhaust gases of your engine can cause nausea, delirium and potentially death unless adequate ventilation is present.

DANGER! Never operate an engine with a fuel or oil leak. The leaking fuel or oil could potentially come in contact with hot surfaces and ignite into flames.



WARNING! Be sure the power feed switch is in the neutral position before turning the key switch to the on (#1) or accessory (#3) position. This prevents accidental carriage movement, which may cause serious injury or death.

WARNING! Do not operate engine without proper and operational spark arrester/muffler. Sparks emitted from the engine exhaust could ignite surrounding materials, causing serious injury or death.

Turn the key switch to the start (#2) position and release.

If the engine needs choking to start, pull the choke cable out until the engine starts. Push the choke wire in after the engine starts.

For more information, see the engine manufacturer's operation manual.

If the fuel tank was recently filled or replaced, squeeze the primer bulb once or twice before trying to start the engine. **NOTE:** If pumping problems are experienced, make sure the out-flow end of the hose line is connected to the fuel filter. If pumping problems are still experienced, hold the primer bulb in a vertical position while squeezing. This allows the fuel check valve to operate properly.

NOTE: When the clutch handle is engaged, an accelerator pump is activated which supplies fuel to the engine carburetor. To avoid flooding the carburetor and possibly fouling the spark plugs, do not engage the clutch lever repeatedly without the engine running.

1 Operation

Starting The Engine

Engine Shutoff

Turn the key switch to the off (#0) position.

SECTION 2 MAINTENANCE

Refer to the manufacturer's manual for maintenance intervals and procedures unless otherwise instructed in this manual. Follow the manufacturer's recommendations for dusty conditions.



IMPORTANT! This manual only provides information about additional procedures or procedures to be performed at different time intervals than found in the manufacturer's manuals. Refer to the manufacturer's manual for complete maintenance instructions.

2.1 Safety

Use caution when performing maintenance or service to the engine.

DANGER! Always be aware of and take proper protective measures against rotating shafts, pulleys, fans, etc. Always stay a safe distance from rotating members and make sure that loose clothing or long hair does not engage rotating members resulting in possible injury.

DANGER! Engine components can become very hot during operation. Avoid contact with any part of a hot engine. The exhaust components of your engine are especially hot during and following operation. Contact with hot engine components can cause serious burns. Therefore, never touch or perform service functions on a hot engine. Allow the engine to cool sufficiently before beginning any service function.



WARNING! Remove the blade before performing any engine service. Failure to do so may result in serious injury.

WARNING! Always wear proper and necessary safety equipment when performing service functions. Proper safety equipment includes eye protection, breathing protection, hand protection and foot protection.





This symbol identifies the interval (hours of operation) at which each maintenance procedure should be performed. "AR" signifies maintenance procedures which should be performed as required.

2.2 Cooling System

-  Wash the engine or brush off sawdust and debris every 50 hours of operation. Clean the grass screen, cooling fins, and external surfaces. Remove any dust, dirt or oil. See engine manual for further instructions.

2.3 Air Filter & Pre-Cleaner

 **WARNING!** Always wear proper and necessary safety equipment when performing service functions. Proper safety equipment includes eye protection, breathing protection, hand protection and foot protection.

-  Service the pre-cleaner every four hours of operation. Service by gently shaking excess sawdust and debris from the foam piece.

-  Clean the air filter (air cleaner element) and pre-cleaner (element wrapper) every eight hours of operation. See the engine manual for further instructions.

-  Replace the air filter (cleaner) every 200 hours of operation.

-  Replace the pre-cleaner (element wrapper) every 2000 hours of operation.

2.4 Fuel Filter

-  Replace the fuel filter every 100 hours of operation.

2.5 Battery



Check the battery electrolyte level every 50 hours of operation. See manufacturer's manual for instructions.



DANGER! Batteries expel explosive gases. Keep sparks, flames, burning cigarettes, or other ignition sources away at all times. Always wear safety goggles and a face shield when working near batteries. Failure to do so will cause serious injury.¹



WARNING! Battery posts, terminals and related accessories contain lead and lead compounds, chemicals known to the State of California to cause cancer and reproductive harm. Wash hands after handling.

1. Battery Council International, copyright 1987

2.6 Alternator Belt



Adjust the alternator belt as needed. Check the alternator belt for tension and wear when battery is not charging properly or when the alternator belt is squealing. To tighten the belt, loosen the adjustment bolt and lock washer. Pivot the alternator away from the motor until the belt has 7/16" (11 mm) deflection with a 5 lb. deflection force. Retighten the adjustment bolt.

See Figure 2-1.

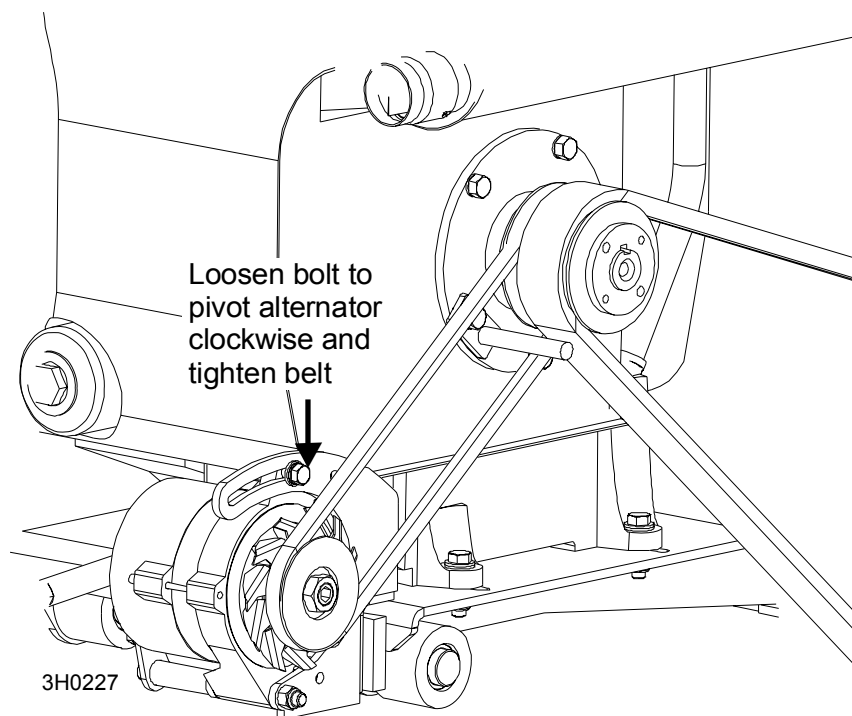

FIG. 2-1

2.7 RPM Adjustments



WARNING! Remove the blade before performing any engine service. Failure to do so may result in serious injury.

200

Check the RPM with a tachometer after the first 20 hours of operation and every 200 hours thereafter. High-end RPM should be 3750 RPM and low-end RPM should be 1800 RPM (± 100).

Before checking the RPM, make sure belt and brake strap tensions are correct (See Saw-mill Maintenance). Also check oil, fuel, and coolant levels.

Make sure the throttle cable does not affect the engine RPM when the clutch handle is disengaged. Make sure the cable is not bent or kinked. Check that the cable spring, cable guide, cable, and throttle brackets are aligned. **NOTE:** It is important that the above components are aligned. Proper alignment allows any slack in the cable (when engine is idling) to slide down into the cable spring. This maintains free operation of the cable and prevents the cable from kinking. Make sure the shoulder bolt does not rub against the crankcase vent tube.

1. Start the engine to measure the low-end RPM.
2. Refer to the engine manual to adjust the low-end RPM.
3. Engage the clutch handle to throttle the engine and measure the high-end RPM. The high-end RPM is factory-set at 3750. Readjust the throttle cable if necessary to increase or reduce the high-end engine speed.

The throttle cable should be tensioned just enough so that the engine revs as soon as the clutch/brake handle is engaged. **NOTE:** A properly adjusted throttle will extend the cable spring 1/4" to 3/8" (6.4 - 9.5 mm) when running and have a slight amount of slack in the cable when idling.

2.8 Miscellaneous Maintenance

50

Clean and inspect the spark arresters every 50 hours of operation. Replace if damaged.

100

Inspect the spark plugs every 100 hours of operation. Remove any deposits and adjust gap if necessary. See engine manual for further information.

CAUTION! Do not remove the plug wire to check for electrical spark. Damage to the ignition circuit will result.

SECTION 3 REPLACEMENT PARTS

3.1 Fuel Tank Assembly

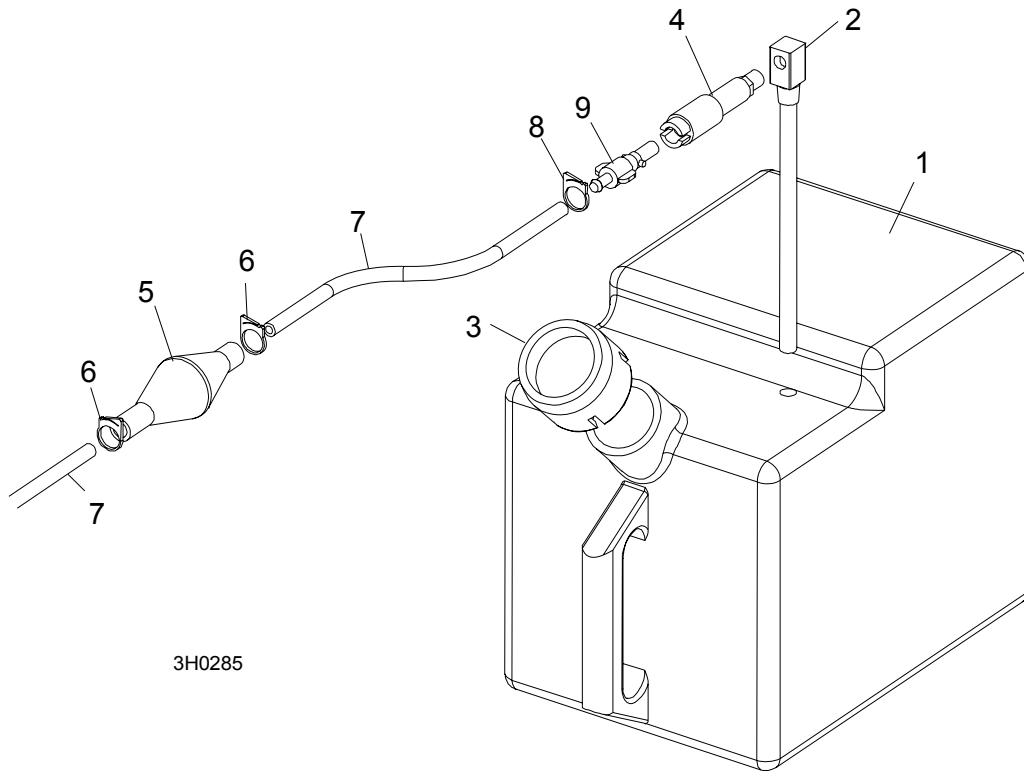

REF	DESCRIPTION (◆ Indicates Parts Available In Assemblies Only)	PART #	QTY.	
	TANK ASSEMBLY, 5-GALLON RED GASOLINE	A12285	1	
1	Tank, 5-Gallon Red Fuel	P12167	1	◆
2	Pickup, 9" Fuel	P12172	1	
3	Cap, 3 or 5-Gallon Fuel Tank	P09683	1	
4	Fitting, 1/4" NPT Plastic Female Disconnect	P12175	1	
	HOSE, FUEL LINE WITH PRIMER BULB	014497	1	
	Bulb Kit, Fuel Primer Replacement	014496	1	
5	Bulb, Fuel Primer	014481	1	◆
6	Clamp, 1/2" OD Plastic Hose	P12374	2	
	Instruction Sheet, Fuel Primer Bulb Replacement	014496-590	1	
7	Hose, 1/4" ID Fuel	R01890-1	2 m	
8	Clamp, 1/2" OD Plastic Hose	P12374	1	
9	FITTING, 1/4" NPT PLASTIC MALE DISCONNECT	P12176 ¹	1	

¹ Replacement requires qty. 1 hose clamp (P12374).

3 Replacement Parts

Engine Mount Assembly

3.2 Engine Mount Assembly

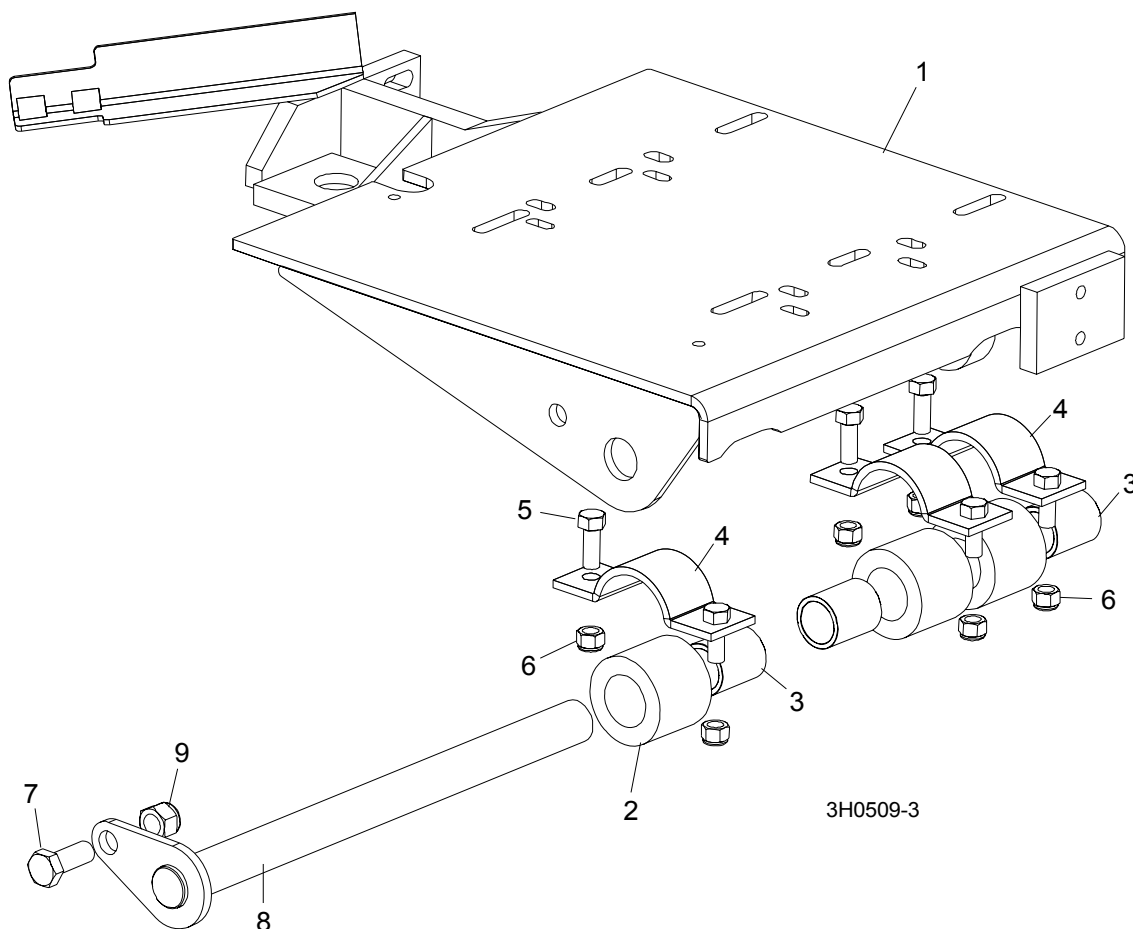

REF	DESCRIPTION (◆ Indicates Parts Available In Assemblies Only)	PART #	QTY.	
1	MOUNT WELDMENT, KOHLER ENGINE	086803-1	1	◆
	BUSHING ASSEMBLY, MOTOR MOUNT	016380	3	
2	Bushing, 2" OD x 2"	016378	1	◆
3	Bearing, 1" x 1 1/4" x 2"	016379	1	◆
4	CLAMP WELDMENT, MOTOR MOUNT PIVOT BUSHING	086235	3	
5	BOLT, M10-1.5X25MM HH GR8.8	F81003-11	3	
	BOLT, M10X45MM,HEX HEAD,FULL THRD,ZINC	F81003-31	3	
6	NUT, M10, NYLON HEX ZINC LOCK	F81033-11	6	
7	BOLT M12X30-8.8	F81004-22	1	
8	PIN WELDMENT, ENGINE MOUNT PIVOT	014154	1	
9	NUT, M12, HEXAGON, NYLON, ZINC, LOCK	F81034-2	1	
10	WASHER, M12, FLAT, ZINC	F81056-1	1	

3.3 Engine Assembly

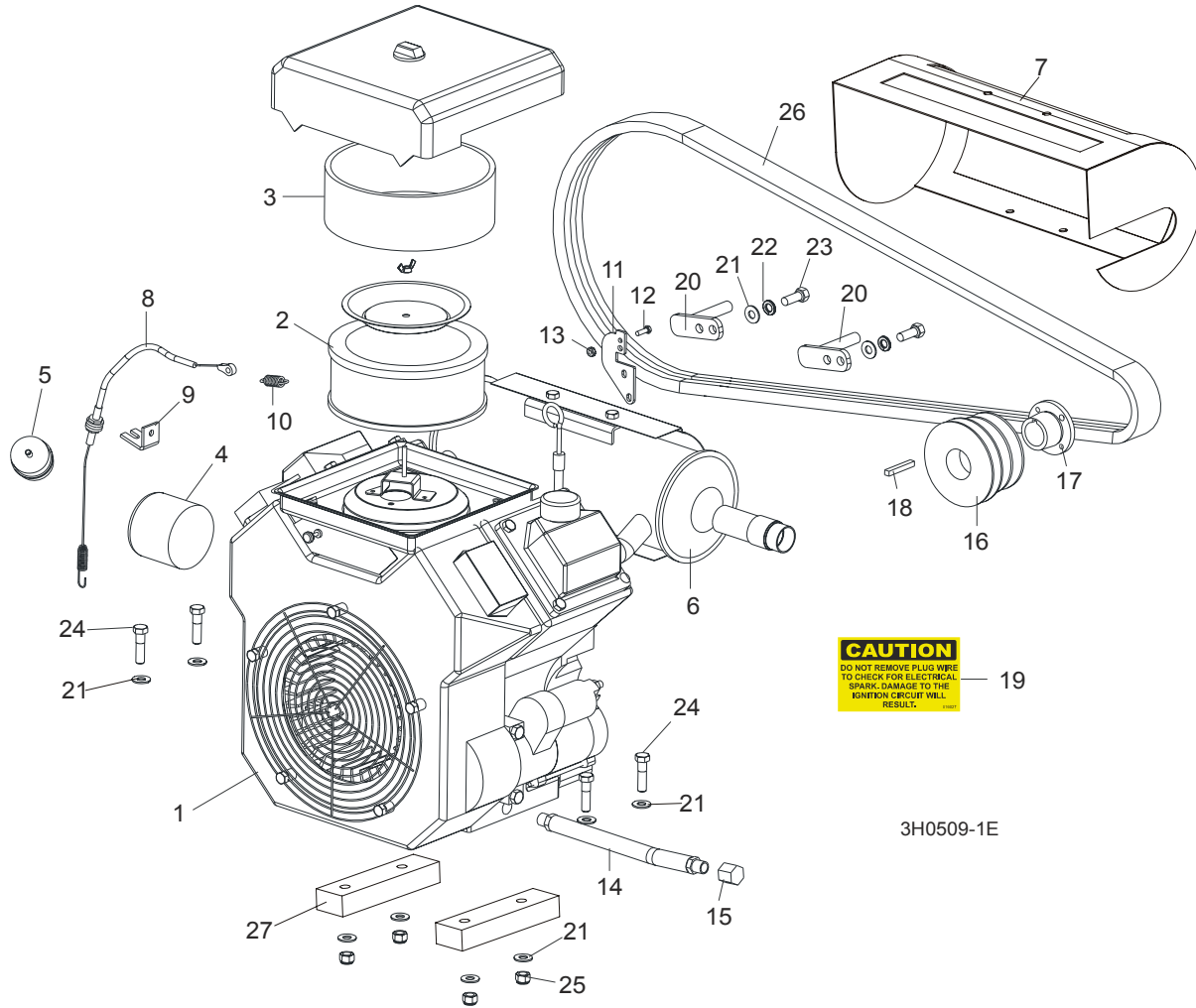

CAUTION
DO NOT REMOVE PLUG WIRE
TO CHECK FOR ELECTRICAL
SPARK. DAMAGE TO THE
IGNITION CIRCUIT WILL
RESULT.

3H0509-1E

REF	DESCRIPTION (◆ Indicates Parts Available In Assemblies Only)	PART #	QTY.	
	ENGINE ASSEMBLY, 25HP KOHLER	015955	1	
1	Engine, 25Hp Kohler CH25	P12529	1	◆
2	Filter, Kohler Air #24-083-03-S	092347	1	◆
3	Pre Cleaner, Kohler #24-083-05-S	092348	1	◆
	Plug, RC12YC Kohler Spark #12-132-02-S	P12757	2	
4	Filter, Kohler Oil #52-050-02-S	092349	1	
5	Filter, Kohler Fuel #25-050-02-S	092350	1	
6	Muffler, Kohler #24-786-12-S	092351	1	◆
7	Guard, Muffler, Kohler	091859-1	1	
8	Cable, 18" Throttle	P12313	1	
	Spring, Throttle	016033	1	

3 Replacement Parts

Engine Assembly

9	Bracket, Throttle Cable Mount	091567-1	1	
10	Spring, .5" x .08" x 1 3/8" Extension	015952	1	
11	Bracket, G25 Throttle	091565-1	1	
12	Bolt, M5x16, HH, GR 8.8, Zinc	F81000-20	1	
13	Nut, M5-8, HEX, NYLON LOCK ZINC	F81030-2	1	
14	Hose, 7" Oil Drain	P10082	1	
15	Cap, Oil Drain 3/8" Pipe	P04332	1	
	Oil, 10W30 Type CD	L04869-1	.5 Gal	◆
16	Pulley, Zinc	091566-1	1	
17	Bushing, Split Taper	091572	1	
18	Key, 1/4" x 1/4" x 1 11/16"	S04124	1	
19	Decal, Kohler Spark Caution	016027	2	
20	Bracket Weldment, Drive Belt Support Painted	091582-1	2	◆
21	WASHER, FLAT, M10, ZINC	F81055-1	10	
22	WASHER, M10 SPLIT LOCK ZINC	F81055-2	2	
23	BOLT, 3/8-16X3/4 HH GR2	F05007-27	2	
24	BOLT, M10X30MM, HEX HEAD, GR 5.8 ZINC	F81003-20	4	
25	NUT, M10, NYLON HEX ZINC LOCK	F81033-1	4	
26	BELT, 2BX72 DRIVE	P09555-2	1	
27	BAR, GP25 ENGINE MOUNT PTD	091564-1	2	

3.4 Alternator Assembly

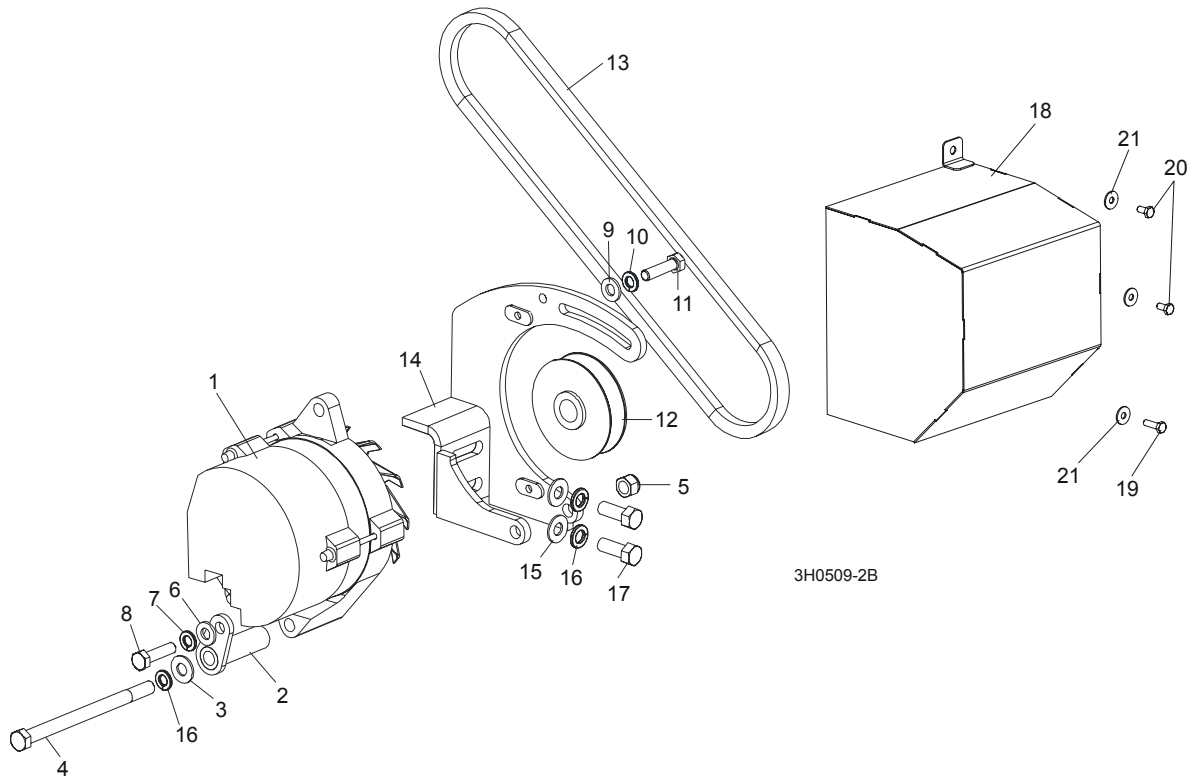

3H0509-2B

REF	DESCRIPTION (◆ Indicates Parts Available In Assemblies Only)	PART #	QTY.
1	ALTERNATOR, 12V 105A	050287	1
2	BRACE, ALTERNATOR	W12761	1
3	WASHER, FLAT, M10, ZINC	F81055-1	1
4	BOLT, 3/8-16 X 5 1/2" HEX HEAD FULL THREAD	F05007-34	1
5	NUT, 3/8-16 HEX NYLON LOCK	F05010-10	1
6	WASHER, M8, FLAT, ZINC	F81054-1	1
7	WASHER, 8,2 SPLIT LOCK ZINC	F81054-4	1
8	BOLT, M8 X 25MM HEX HEAD GR 5.8 ZINC	F81002-5	1
9	WASHER, M8, FLAT, ZINC	F81054-1	1
10	WASHER, 8,2 SPLIT LOCK ZINC	F81054-4	1
11	BOLT, M8 X 25MM HEX HEAD GR 5.8 ZINC	F81002-5	1
12	PULLEY, ALTERNATOR	P03806	1
13	BELT, ALTERNATOR E15 13X920 "A"	085753	1
	WIRE ASSEMBLY, G25 ALTERNATOR/STARTER	024308	1
	WIRE ASSEMBLY, 61/105 AMP ALTERNATOR PLUG	015969	1
14	BRACKET, ALTERNATOR MOUNT	092015-1	1

3**Replacement Parts***Alternator Assembly*

15	WASHER, FLAT, M10, ZINC	F81055-1	2	
16	WASHER, M10 SPLIT LOCK ZINC	F81055-2	3	
17	BOLT, M10X20MM,HEX HEAD,GR 5.8 ZINC	F81003-1	2	
18	GUARD, ALTERNATOR BELT	091583-1	1	
19	BOLT, M6X20MM, HH, FULL THREAD, ZINC	F81001-2	1	
20	BOLT, M6X12MM HEX HEAD ZINC	F81001-7	2	
21	WASHER, M6, FLAT, ZINC	F81053-11	3	

3.5 Engine Pulley Guards

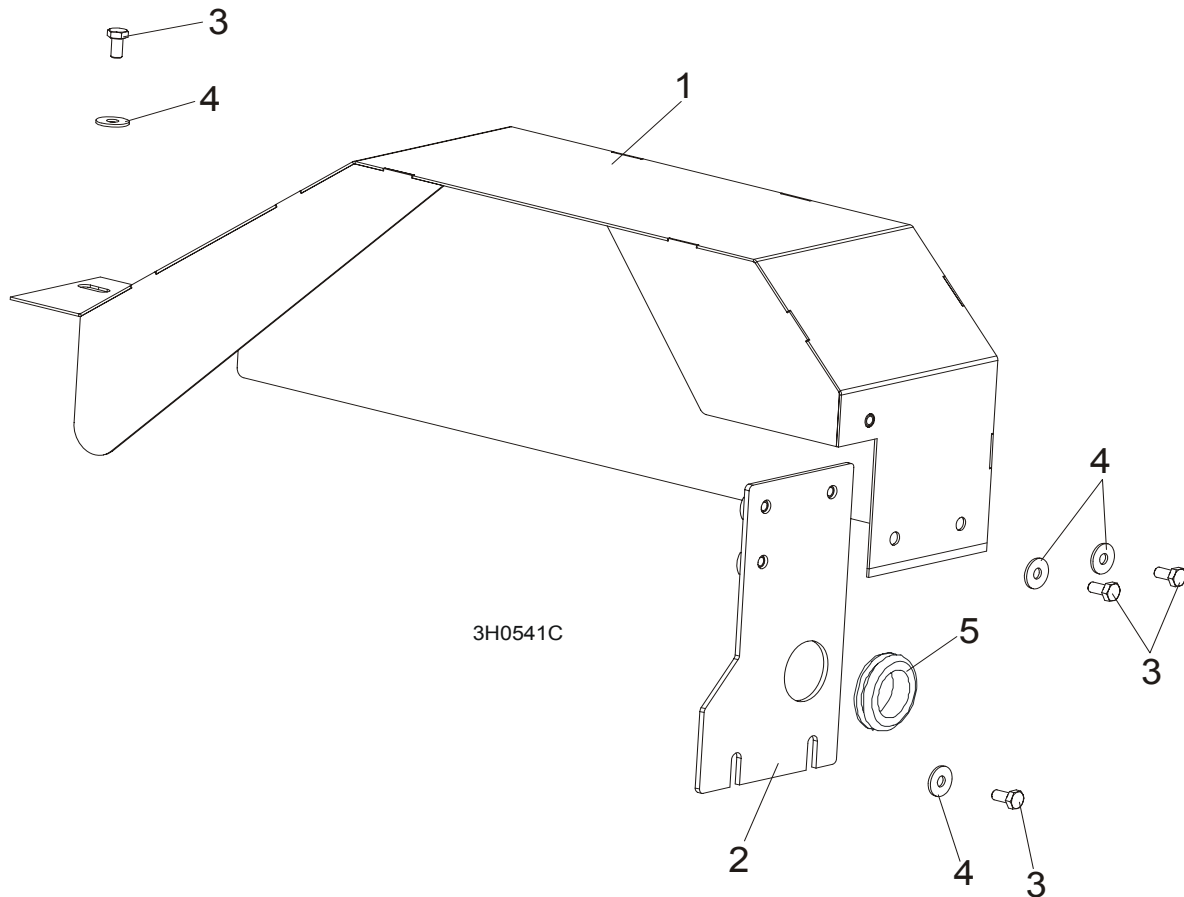

REF	DESCRIPTION (◆ Indicates Parts Available In Assemblies Only)	PART #	QTY.
1	GUARD WELDMENT, G18/G20/G25 ENGINE PULLEY	091571-1	1
2	GUARD, G18/G20/G25 SIDE ENGINE PULLEY	087178-1	1
3	BOLT, M6X12MM HEX HEAD ZINC	F81001-7	4
4	WASHER, M6, FLAT, ZINC	F81053-11	4
5	GROMMET, 1" ID RUBBER	P11765	1

SECTION 4 ELECTRICAL INFORMATION

4.1 Electrical Symbol Diagram, G25 LT40 Series

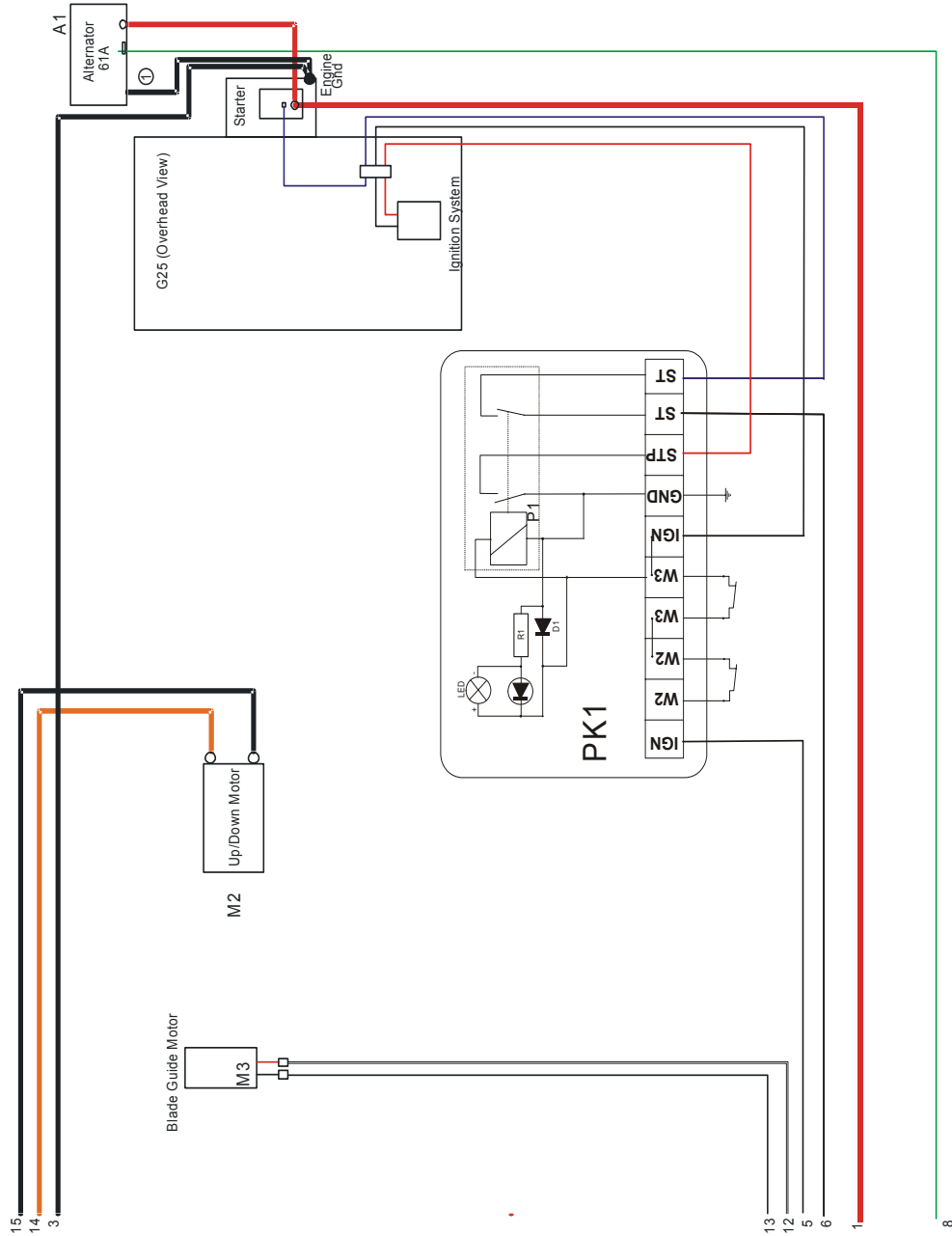

RYS. 4-1

4.2 Electrical Symbol Diagram, LT40 Series

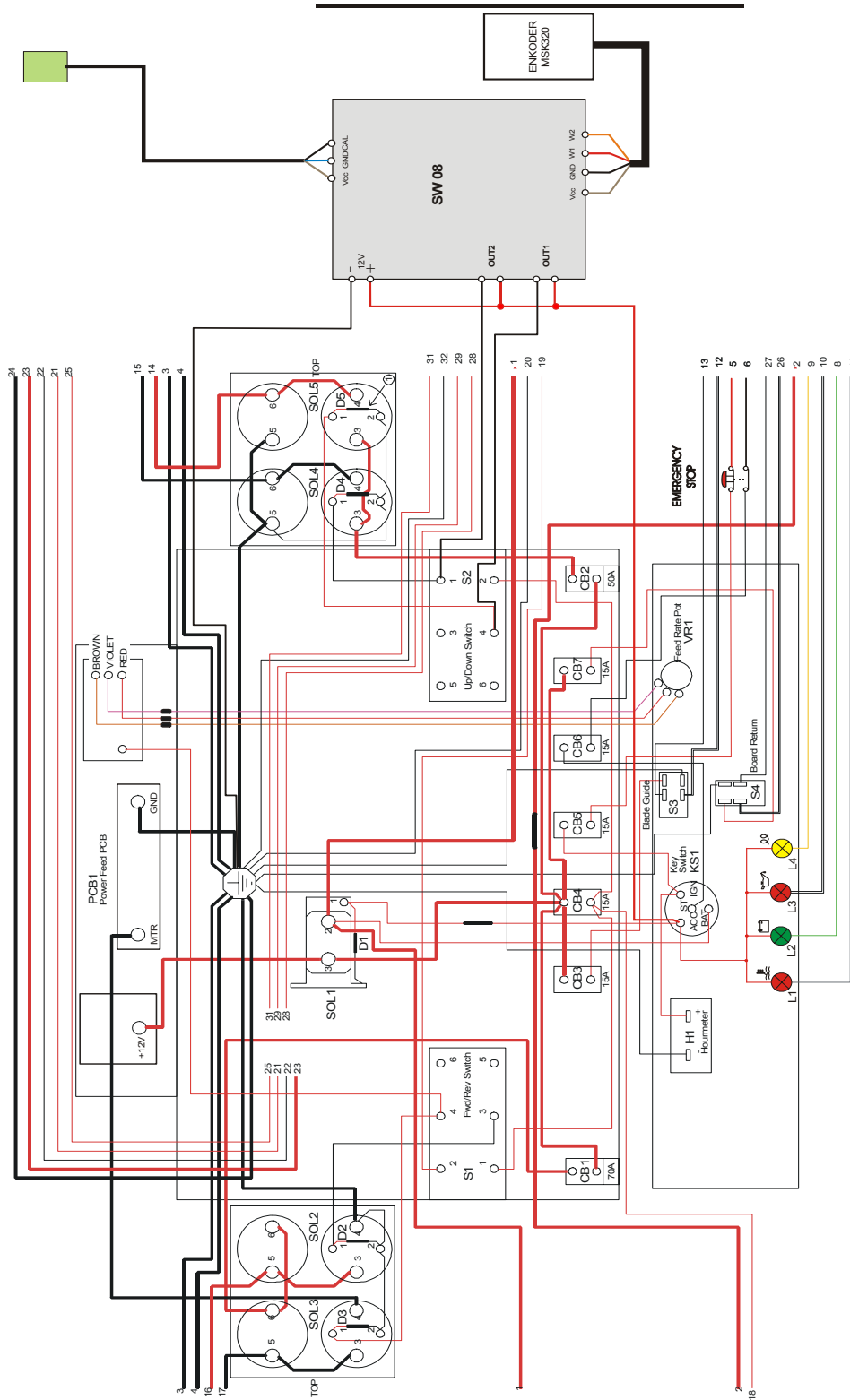

RYS. 4-2

4.3 Electrical Components, G25 LT40 non-hydraulic

Item	Mfg. Part No.	Manufacturer	WM Part #	Description
A1	CS-130	Delco-Remy	050287	Alternator, 12 Volt, 105 A
B1	#95601	BANNER	088322	Battery, 12 V
CB1	30128-30	Cole-Hersee	E20486	Circuit Breaker, 30 Amp, 12 Volt, For Power Feed Motor, Auto Reset
F1	RL-150	Gould	023361	Fuse Link, 150 Amp, 250 Volt For Main + 12 Volt Starter, Alternator
H1	T14BH517BC9	ENM Corp.	015401	Hour Meter, 12 Volt, Low Power T14 Series
KS1	121801	General	P04350	Key Switch, 4-position (Accessory, Off, Ignition, Start)
M1	PR4R0009Q	Owosso	014359	Motor, 12 Volt Power Feed
M2	PR-4P07Q	Owosso	A07974	Motor, 12 Volt Up/Down
M3	P09698-1	Klauber	A10365	Motor, 12 Volt Blade Guide Arm 53:1 Gear
PCB1	015410	Wood-Mizer	015410	Circuit Board, Control Box
PCB2	015416	Wood-Mizer	015416	Circuit Board, LED Circuit (Gas/Elec)
S1	2601-AF2-S11	Square D	E20439	Drum Switch, (U.S.), Power Feed Fwd/Reverse Motor
S2	2601-AF2-S12	Square D	E20440	Drum Switch, Up/Down Motor
S3	34-591Q	Pollak	024200	Toggle Switch, Blade Guide In/Out Motor
PK1	-	-	092284	Relay, Safety Key Switches
P1	XB4BS542	Schneider	086556	Switch, Emergency Stop

TABELA 4-1

4.4 Electrical Components, G25 LT40 hydraulic

Item	Mfg. Part No.	Manufacturer	WM Part #	Description
A1	CS-130	Delco-Remy	050287	Alternator, 12 Volt, 105 A
B1	#95601	BANNER	088322	Battery, 12 V
CB1	30128-30	Cole-Hersee	E20486	Circuit Breaker, 30 Amp, 12 Volt, For Power Feed Motor, Auto Reset
F1	RL-150	Gould	023361	Fuse Link, 150 Amp, 250 Volt For Main + 12 Volt Starter, Alternator
F2	RL-225	Gould	P11550	Fuse Link, 225 Amp, 250 Volt For Hydraulic +12 Volt Circuit
H1	T14BH517BC9	ENM Corp.	015401	Hour Meter, 12 Volt, Low Power T14 Series
KS1	121801	General	P04350	Key Switch, 4-position (Accessory, Off, Ignition, Start)
M1	PR4R0009Q	Owosso	014359	Motor, 12 Volt Power Feed
M2	PR-4P07Q	Owosso	A07974	Motor, 12 Volt Up/Down
M3	P09698-1	Klauber	A10365	Motor, 12 Volt Blade Guide Arm 53:1 Gear
M4	8111	Monarch Hyd.	P09955	Motor, 12 Volt Hydraulic Pump
PCB1	015410	Wood-Mizer	015410	Circuit Board, Control Box Power Feed
PCB2	015416	Wood-Mizer	015416	Circuit Board, LED Circuit (Gas/Elec)
S1	2601-AF2-S11	Square D	E20439	Drum Switch, (U.S.), Power Feed Fwd/Reverse Motor
S2	2601-AF2-S12	Square D	E20440	Drum Switch, Up/Down Motor
S3	34-591Q	Pollak	024200	Toggle Switch, Blade Guide In/Out Motor
S4	024198	Wood-Mizer	024198	Switch, Hydraulic Pump Levers
SOL1	586-902	Stancor	015470	Solenoid, 200A 12V SPST Hydraulic Pump Motor
PK1	-	-	092284	Relay, Safety Key Switches
P1	XB4BS542	Schneider	086556	Switch, Emergency Stop

TABELA 4-2