

Wood-Mizer®

Replacement Parts

LX100

rev. A2.02



Safety is our #1 concern! Read and understand all safety information and instructions before operating, setting up or maintaining this machine.

Form #802

Table of Contents

Section-Page

SECTION 1	GENERAL INFORMATION	1-1
1.1	How To Use The Parts List	1-1
1.2	Sample Assembly	1-1
SECTION 2	BED FRAME PARTS	2-1
2.1	Bed Frame Segment	2-1
2.2	Bed Frame Extension	2-3
2.3	Bed Frame M Segment	2-4
2.4	Bed Frame S Segment	2-5
2.5	Bumpers	2-6
2.6	Bumpers	2-7
2.7	Bed Foot	2-8
2.8	Cross Rail Cover Set (Option)	2-9
2.9	Additional Cross Bars w/Covers & Side Support Rollers (Option) ..	2-10
2.10	Additional Cross Bar w/Cover (Option)	2-11
2.11	Side Support Roller (Option)	2-12
SECTION 3	BLADE GUIDE ROLLERS & ARM	3-1
3.1	Blade Guide Assembly, Idle Side	3-1
3.2	Blade Guide Assembly, Drive Side	3-2
3.3	Blade Guide Roller Guard	3-3
3.4	Blade Guide Arm Assembly, E15	3-4
3.5	Blade Guide Arm w/Drive	3-5
3.6	Blade Guide Arm Drive	3-7
SECTION 4	BLADE WHEELS & TENSIONER	4-1
4.1	Blade Wheel Assembly, Drive Side (E15)	4-1
4.2	Blade Wheel Assembly, Drive Side - E11	4-2
4.3	Blade Wheel Assembly, Idle Side	4-3
4.4	Blade Tensioner Assembly	4-5
SECTION 5	SAW HEAD	5-1
5.1	Blade Housing Cover	5-1
5.2	Water Lube Assembly	5-3
5.3	Slide Pads	5-4
5.4	Saw Head Decals	5-6
SECTION 6	SAWMILL MAST	6-1
6.1	EH11S Mast and Up/Down Limit Switches	6-1
6.2	Handle for Manual Feed	6-4
6.3	E15 Sawmill Mast (African Version)	6-5

Table of Contents

Section-Page

6.4	EC Mast	6-8	
SECTION 7 POWER FEED SYSTEM			7-1
7.1	Power Feed Assembly	7-1	
7.2	Power Feed Cover Assembly	7-3	
SECTION 8 UP/DOWN SYSTEM			8-1
8.1	Up/Down Drive Assembly	8-1	
8.2	Blade Height Scale Assembly	8-2	
8.3	Up/Down Sprockets	8-4	
SECTION 9 MOTOR ASSEMBLY			9-1
9.1	E11/E15 Motor Kit	9-1	
9.2	E11S/E15S Motor Kit	9-2	
9.3	E15-EC Motor Kit	9-3	
9.4	Electric Box	9-4	
9.5	Electric Box, E15-EC	9-5	
9.6	AC Control Box	9-6	
9.7	Blade Lube Kit	9-8	

SECTION 1 GENERAL INFORMATION

1.1 How To Use The Parts List

- Use the index above to locate the assembly that contains the part you need.
- Go to the appropriate section and locate the part in the illustration.
- Use the number pointing to the part to locate the correct part number and description in the table.
- Parts shown indented under another part are included with that part.
- Parts marked with a diamond (◆) are only available in the assembly listed above the part.

See the sample table below. Sample Part #A01111 includes part F02222-2 and subassembly A03333. Subassembly A03333 includes part S04444-4 and subassembly K05555. The diamond (◆) indicates that S04444-4 is not available except in subassembly A03333. Subassembly K05555 includes parts M06666 and F07777-77. The diamond (◆) indicates M06666 is not available except in subassembly K05555.

1.2 Sample Assembly				
REF.	DESCRIPTION (◆ Indicates Parts Available In Assemblies Only)	PART #	QTY	
	Sample Assembly, Complete (Includes All Indented Parts Below)	A01111	1	
1	Sample Part	F02222-22	1	
	Sample Subassembly (Includes All Indented Parts Below)	A03333	1	
2	Sample Part (◆ Indicates Part Is Only Available With A03333)	S04444-4	1	◆
	Sample Subassembly (Includes All Indented Parts Below)	K05555	1	
3	Sample Part (◆ Indicates Part Is Only Available With K05555)	M06666	2	◆
4	Sample Part	F07777-77	1	

To Order Parts:

- From Europe call our European Headquarters and Manufacturing Facility in Kolo, Poland at **+48-63-2626000**. From the continental U.S., call our toll-free Parts hotline at **1-800-525-8100**. Have your customer number, vehicle identification number, and part numbers ready when you call. From other international locations, contact the Wood-Mizer distributor in your area for parts.

Office Hours:

Country	Monday - Friday	Saturday	Sunday
Poland	7-15	Closed	Closed
US	8 a.m.- 5 a.m.	8 a.m.- 12 p.m.	Closed



CAUTION! It is strongly recommended that only original spare parts be used.

SECTION 2 BED FRAME PARTS

2.1 Bed Frame Segment

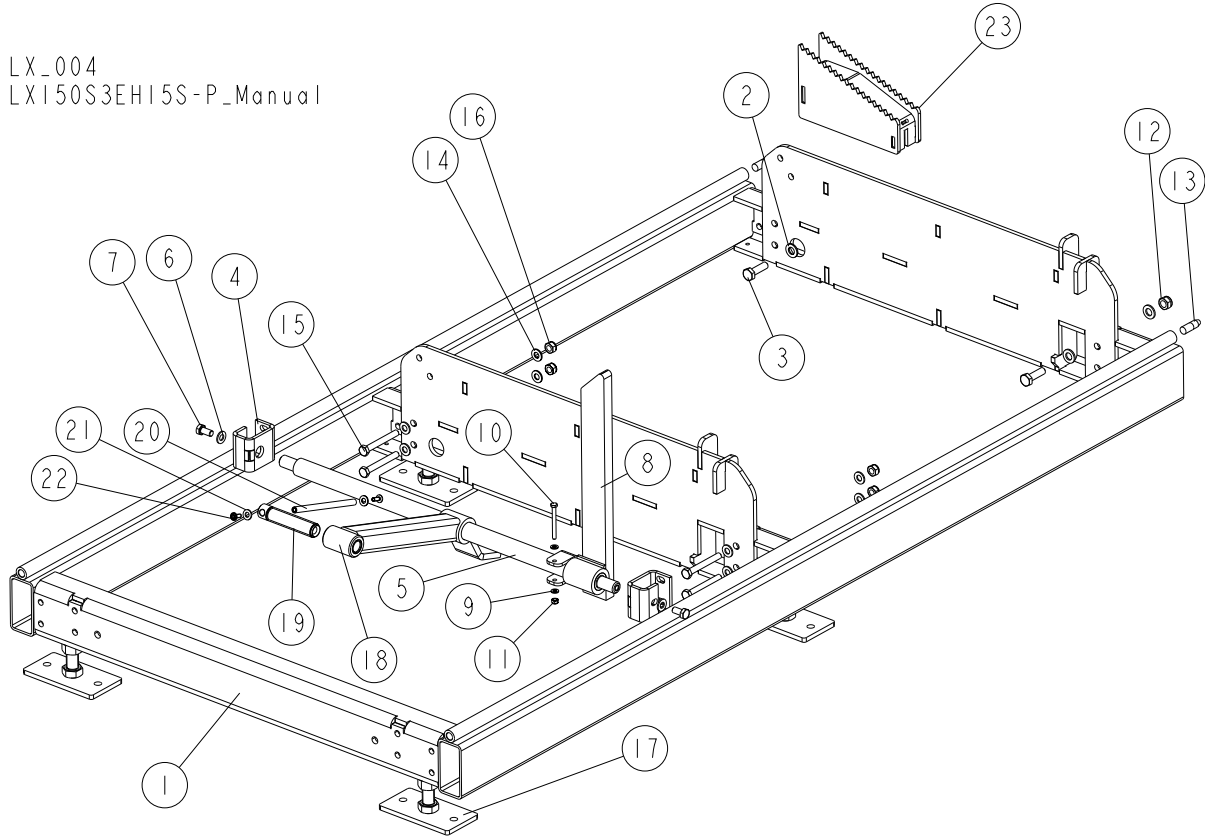

REF.	DESCRIPTION (◆ indicates parts available in assemblies only)	PART #	QTY
	SEGMENT, S - COMPLETE	516516	1/0
	SEGMENT, M - COMPLETE	516513	0/1
1	SEGMENT WELDMENT, S (3 CROSS RAILS)	516261-1	1/0
	SEGMENT WELDMENT, M (4 CROSS RAILS)	516250-1	0/1
2	WASHER, 13 FLAT ZINC	F81056-1	4
3	BOLT, M12X40-8.8 HEX HEAD FULL THREAD ZINC	F81004-4	2
	SIDE SUPPORT ASSEMBLY	517242	1
4	BRACKET, LOG CLAMP MOUNTING	500338-1	2
5	ROD, LOG CLAMP MAIN	515059-1	1
6	WASHER, 10.5 FLAT ZINC	F81055-1	2
7	BOLT, M10X20-5.8 HEX HEAD FULL THREAD ZINC	F81003-1	2
	SUPPORT, SIDE - COMPLETE	517721	1
8	SUPPORT WELDMENT, SIDE	517722-1	1
9	WASHER, 6.4 FLAT ZINC	F81053-1	2
10	BOLT, M6X60-8.8 HEX HEAD FULL THREAD ZINC	F81001-9	1
11	NUT, M6-8-B HEX NYLON ZINC LOCK	F81031-2	1
12	NUT, M12 8 HEX NYLON ZINC LOCK	F81034-2	2
13	PIN, SPECIAL	090675	2
14	WASHER, 10.5 FLAT ZINC	F81055-1	8

2

BED FRAME PARTS*Bed Frame Segment*

REF.	DESCRIPTION (◆ indicates parts available in assemblies only)	PART #	QTY	
15	BOLT, M10X80-8.8 HEX HEAD ZINC	F81003-50	4	
16	NUT, M10-8-B HEX NYLON ZINC LOCK	F81033-1	4	
17	FOOT, LT15 BED - COMPLETE See Section 2.4	514997	4/6	
18	ARM, LOG CLAMP	521465-1	1/2	
	STUD W/ROD, LOG CLAMP - COMPLETE	507563	1/2	
19	STUD, LOG CLAMP	507463	1	
	COMPLETE ROD	511924	1	
20	ROD, ZINC-PLATED	511923-1	1	
21	WASHER, 8.4 FLAT ZINC	F81054-1	2	
22	SCREW, M6X16 BN 11252 "BOSSARD".	F81001-24	2	
23	WEDGE, LT15 BED	515413-1	1	

2.2 Bed Frame Extension

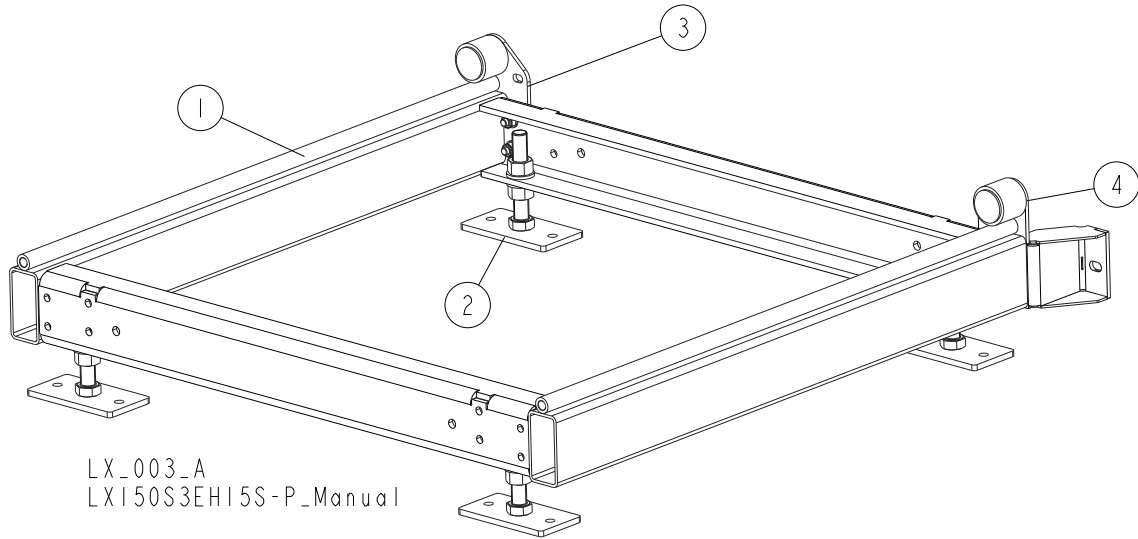

REF.	DESCRIPTION (◆ indicates parts available in assemblies only)	PART #	QTY
	EXTENSION, BED FRAME - COMPLETE	516525	1
1	EXTENSION, BED FRAME	516268-1	1
2	FOOT, LT15 BED - COMPLETE	514997	4
3	BUMPER, LT15 RIGHT - COMPLETE See Section 2.5	515062	1
4	BUMPER, LT15 LEFT - COMPLETE See Section 2.6	517896	1

2.3 Bed Frame M Segment

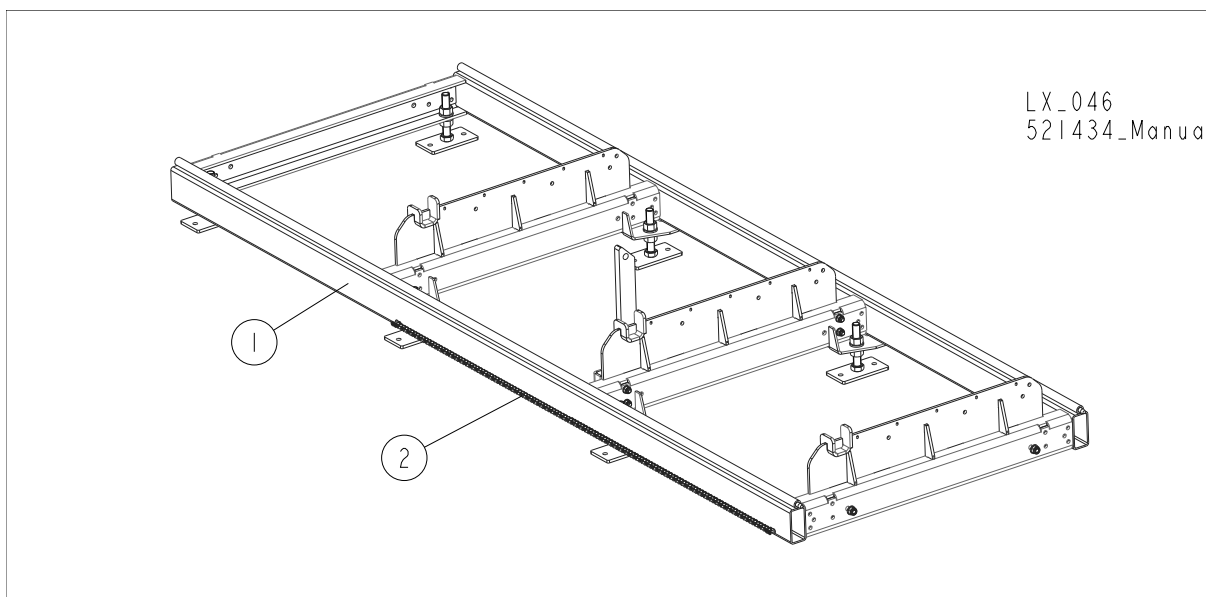

REF.	DESCRIPTION (◆ indicates parts available in assemblies only)	PART #	QTY	
	BED SEGMENT, LX100 M WITH POWER FEED	521434	1	
1	SEGMENT M complete LX100	516513	1	
2	CHAIN 08B; LENGTH.=2,78M (219 LINKS)	521433	1	

2.4 Bed Frame S Segment

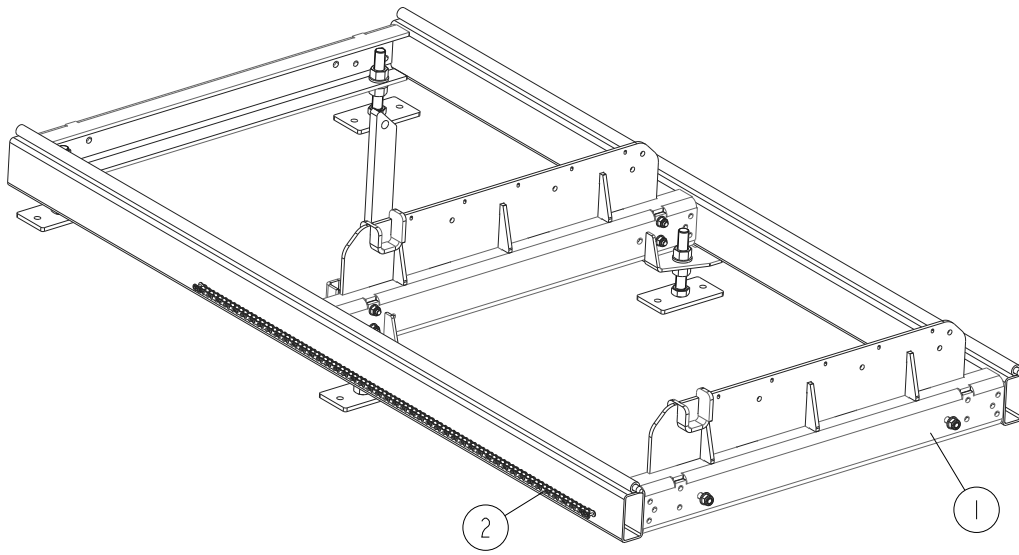

REF.	DESCRIPTION (◆ indicates parts available in assemblies only)	PART #	QTY
	BED SEGMENT, LX100 S WITH POWER FEED	521432	1
1	SEGMENT S, COMPLETE LX100	516516	1
2	CHAIN 08B; LENGTH.=1,87M (147 LINKS)	521431	1

2 BED FRAME PARTS

Bumpers

2.5 Bumpers

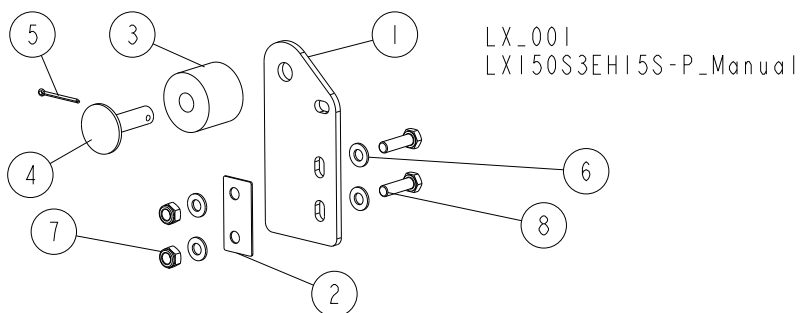

REF.	DESCRIPTION (◆ indicates parts available in assemblies only)	PART #	QTY
	BUMPER, LT15 RIGHT - COMPLETE	515062	1
	BUMPER, LT15 LEFT - COMPLETE	515063	1
1	PLATE, BUMPER	516075-1	1
2	WASHER, BUMPER PLATE SPACER	515061-1	1
3	BUSHING, 11/16X2 1/8X1 3/4 RUBBER	P12165	1
4	MOUNT WELDMENT, CARRIAGE STOP	086182-1	1
5	PIN, S-ZN 4X25 COTTER	F81043-2	1
6	WASHER, 10.5 FLAT ZINC	F81055-1	4
7	NUT, M10-8-B HEX NYLON ZINC LOCK	F81033-1	2
8	BOLT, M10X35 8.8 HEX HEAD FULL THREAD ZINC	F81003-17	2

2.6 Bumpers

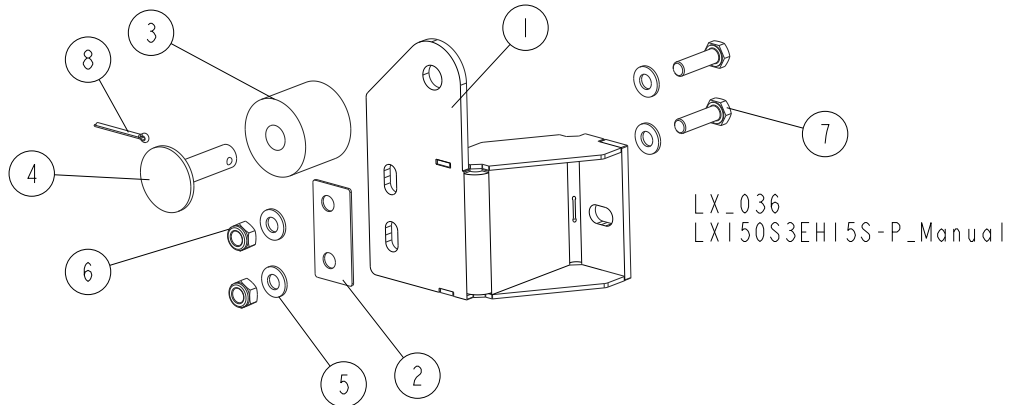

REF.	DESCRIPTION (◆ indicates parts available in assemblies only)	PART #	QTY
	BUMPER, RIGHT - COMPLETE	517897	1/0
	BUMPER, LEFT - COMPLETE	517896	0/1
1	BRACKET WELDMENT, RIGHT	517902-1	1/0
	BRACKET WELDMENT, LEFT	517901-1	0/1
2	WASHER, BUMPER PLATE SPACER	515061-1	1
3	BUSHING, 11/16X2 1/8X1 3/4 RUBBER	P12165	1
4	MOUNT WELDMENT, CARRIAGE STOP	086182-1	1
5	WASHER, 10.5 FLAT ZINC	F81055-1	4
6	NUT, M10-8-B HEX NYLON ZINC LOCK	F81033-1	2
7	BOLT, M10X35 8.8 HEX HEAD FULL THREAD ZINC	F81003-17	2
8	PIN, S-ZN 4X25 COTTER	F81043-2	1

2 BED FRAME PARTS

Bed Foot

2.7 Bed Foot

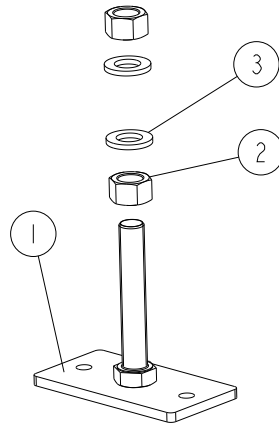

LX_002
LXI50S3EHI5S-P_Manual

REF.	DESCRIPTION (◆ indicates parts available in assemblies only)	PART #	QTY
	FOOT, LT15 BED - COMPLETE	514997	1
1	FOOT WELDMENT, LT15 BED	514996-1	1
2	NUT, M20-8 HEX ZINC	F81037-1	2
3	WASHER, 21 FLAT ZINC	F81059-2	2

2.8 Cross Rail Cover Set (Option)

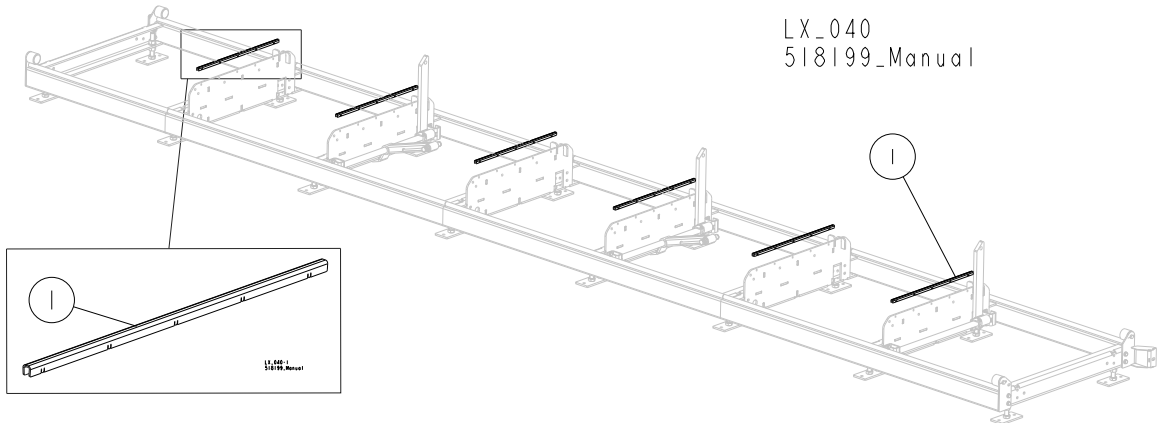

REF.	DESCRIPTION (◆ indicates parts available in assemblies only)	PART #	QTY
	COVER SET, BED CROSS RAIL (FOR LX100 S2 FRAME)	518199-S2	1/-/-
	COVER SET, BED CROSS RAIL (FOR LX100 S3 FRAME)	518199-S3	-/1/-
	COVER SET, BED CROSS RAIL (FOR LX100 S4 FRAME)	518199-S4	-/-/1-
	COVER SET, BED CROSS RAIL (FOR LX100 S5 FRAME)	518199-S5	-/-/1/1
1	COVER, CROSS RAIL	518225	4/6/8/10

2

BED FRAME PARTS

Additional Cross Bars w/Covers & Side Support Rollers (Option)

2.9 Additional Cross Bars w/Covers & Side Support Rollers (Option)

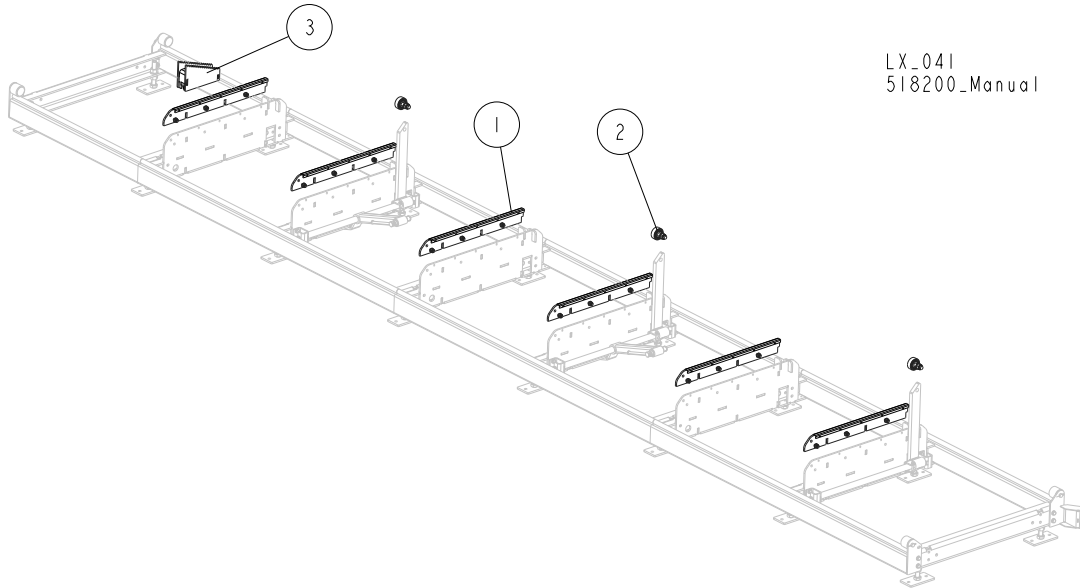

LX_041
518200_Manual

REF.	DESCRIPTION (◆ indicates parts available in assemblies only)	PART #	QTY
	ADDITIONAL CROSS BARS W/COVERS & SIDE SUPPORT ROLLERS (FOR LX100 S2 FRAME)	518200-S2	1/-/-
	ADDITIONAL CROSS BARS W/COVERS & SIDE SUPPORT ROLLERS (FOR LX100 S3 FRAME)	518200-S3	-1/-/-
	ADDITIONAL CROSS BARS W/COVERS & SIDE SUPPORT ROLLERS (FOR LX100 S4 FRAME)	518200-S4	-/-1/-
	ADDITIONAL CROSS BARS W/COVERS & SIDE SUPPORT ROLLERS (FOR LX100 S5 FRAME)	518200-S5	-/-/-1
1	BAR, CROSS W/COVER - ADDITIONAL See Section 2.10	518180	4/2/8/10
2	ROLLER ASSEMBLY, SIDE SUPPORT See Section 2.11	518181	2/3/4/5
3	WEDGE, LX100 WIDE BED	518204-1	1

2.10 Additional Cross Bar w/Cover (Option)

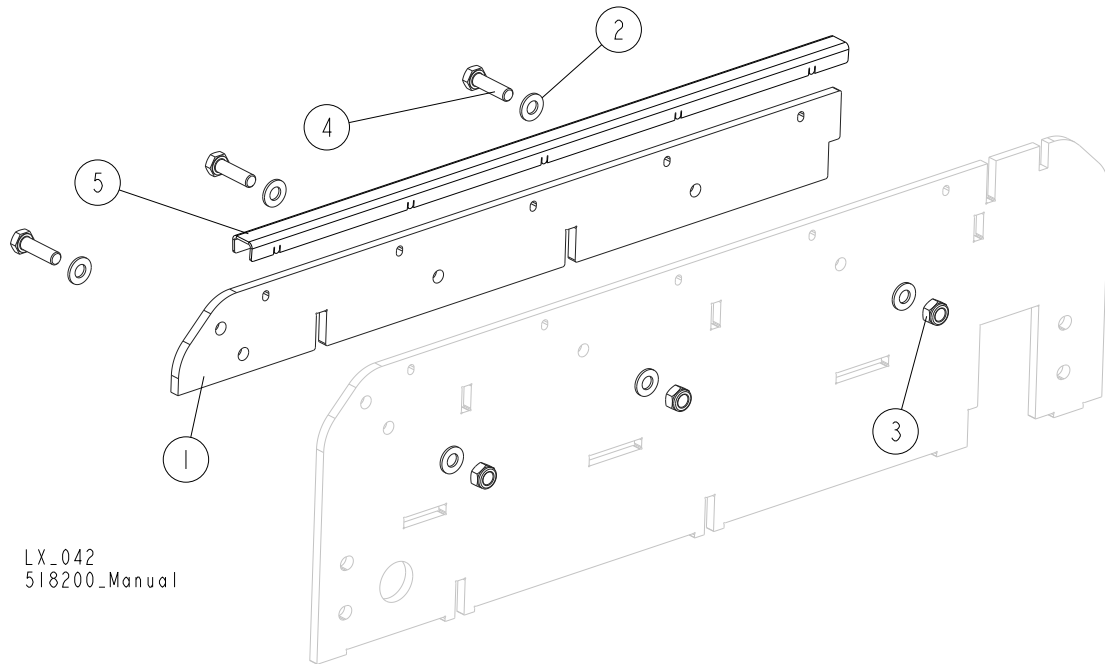

REF.	DESCRIPTION (◆ indicates parts available in assemblies only)	PART #	QTY
	BAR, CROSS W/COVER - ADDITIONAL	518180	1
1	BAR	517730	1
2	WASHER, 10.5 FLAT ZINC	F81055-1	6
3	NUT, M10-8-B HEX NYLON ZINC LOCK	F81033-1	3
4	BOLT, M10X35 8.8 HEX HEAD FULL THREAD ZINC	F81003-17	3
5	COVER, CROSS RAIL (WIDE)	518179	1

2 BED FRAME PARTS

Side Support Roller (Option)

2.11 Side Support Roller (Option)

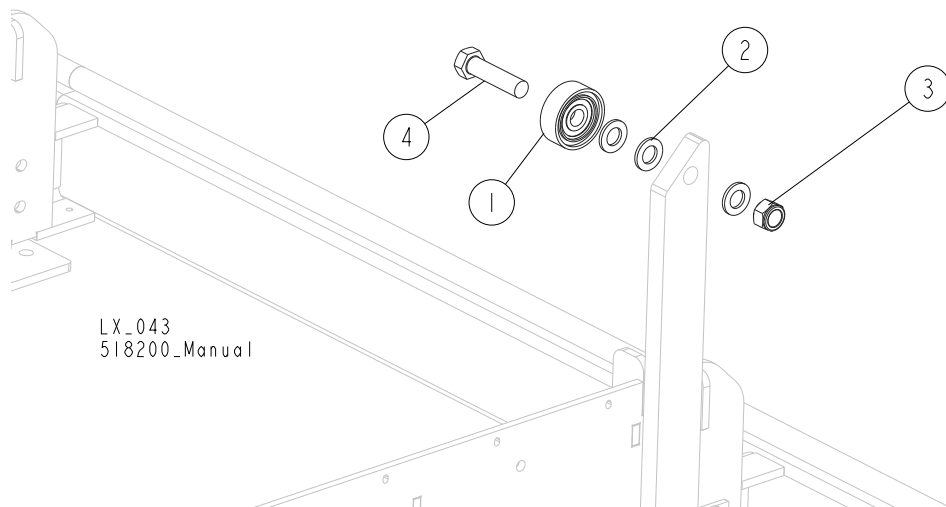

REF.	DESCRIPTION (◆ indicates parts available in assemblies only)	PART #	QTY
	ROLLER ASSEMBLY, SIDE SUPPORT	518181	1
1	ROLLER, SIDE SUPPORT	015014-1	1
2	WASHER, 17 SPLIT LOCK ZINC	F81058-1	3
3	NUT, M16-8 HEX NYLON ZINC LOCK	F81036-2	1
4	BOLT, M16x65-8.8-B HEX HEAD FULL THREAD ZINC	F81006-1	1

SECTION 3 BLADE GUIDE ROLLERS & ARM

3.1 Blade Guide Assembly, Idle Side

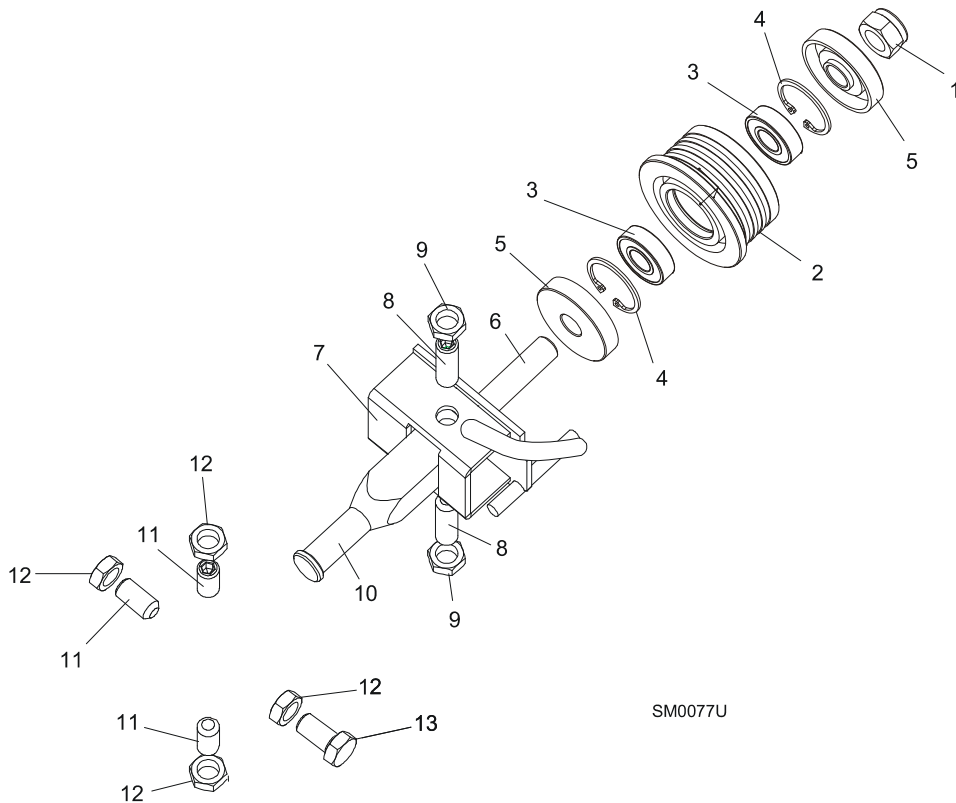

SM0077U

REF.	DESCRIPTION (◆ indicates parts available in assemblies only)	PART #	QTY	
	BLADE GUIDE ASSEMBLY, IDLE SIDE	094683	1	
	Roller, Blade Guide Complete Standard	087887	1	
1	Nut, M12-8 Hex Nylon Zinc Lock	F81034-2	1	
2	Roller, Blade Guide Narrow	087889	1	◆
3	Bearing, 6001 2RSR FAG	087893	2	
4	Ring, W28 Inside Retaining	F81090-9	1	
5	Washer, Zinc-plated Spacer	087891-1	2	
6	Shaft, Blade Guide Roller Zinc-plated	087763-1	1	
7	Bracket Weldment, Idle Side Blade Guide	094681-1	1	
8	Screw, M10x1x40 DIN 913 A2-70 Stainless Steel Set	F81015-2	2	
9	Nut, M10x1-04-ST-A2 ISO 8675 Thin	F81033-10	2	
10	Shaft, Zinc-plated Blade Guide Mount	503588-1	1	
11	SCREW, M10X1X20 DIN 913 STAINLESS STEEL SET	F81015-1	4	
12	NUT, M10x1-04-ST-A2 ISO 8675 THIN	F81033-10	4	

3 Blade Guide Rollers & Arm

Blade Guide Assembly, Drive Side

3.2 Blade Guide Assembly, Drive Side

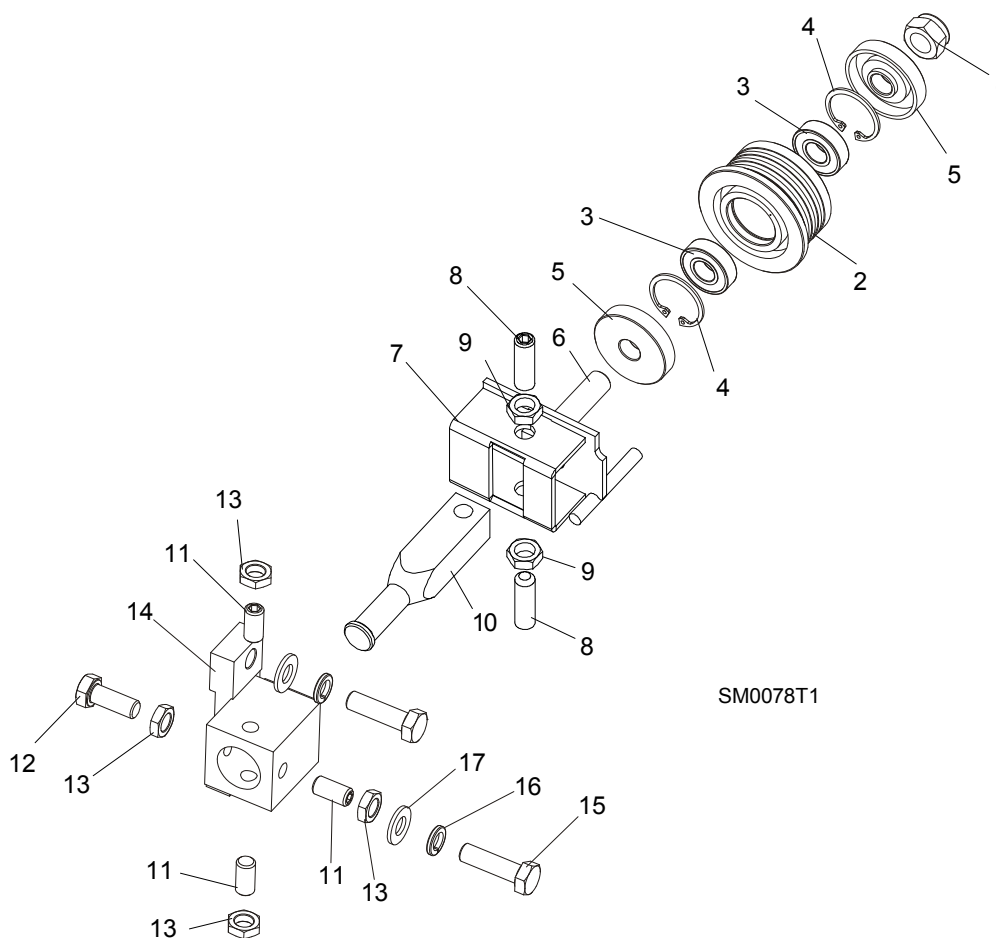

REF.	DESCRIPTION (◆ indicates parts available in assemblies only)	PART #	QTY
	BLADE GUIDE ASSEMBLY, COMPLETE DRIVE SIDE	094682	1
	Roller, Blade Guide Complete Standard	087887	1
1	Nut, M12-8 Hex Nylon Zinc Lock	F81034-2	1
2	Roller, Blade Guide Narrow	087889	1 ◆
3	Bearing, 6001 2RSR FAG	087893	2
4	Ring, W28 Inside Retaining	F81090-9	1
5	Washer, Zinc-plated Spacer	087891-1	2
6	Shaft, Blade Guide Roller Zinc-plated	087763-1	1
7	Bracket Weldment, Blade Guide	094679-1	1
	Screw Kit, Blade Guide Adjustment w/Nuts (for two assemblies)	K09942	1
8	Screw, M10x1x40 DIN 913 A2-70 Stainless Steel Set	F81015-2	2
9	Nut, M10x1-04-ST-A2 ISO 8675 Thin	F81033-10	2
10	Shaft, Zinc-plated Blade Guide Mount	503588-1	1
11	SCREW, M10X1X20 DIN 913 STAINLESS STEEL SET	F81015-1	3
12	BOLT, M10X1X25 DIN 933 STAINLESS STEEL	F81003-28	1
13	NUT, M10x1-04-ST-A2 ISO 8675 THIN	F81033-10	4
14	TUBE, BLADE GUIDE MOUNT	087744	1
15	BOLT, M10X35-8.8 HEX HEAD FULL THREAD ZINC	F81003-17	2
16	WASHER, 10.2 SPLIT LOCK ZINC	F81055-2	2
17	WASHER, 10.5 FLAT ZINC	F81055-1	2

3.3 Blade Guide Roller Guard

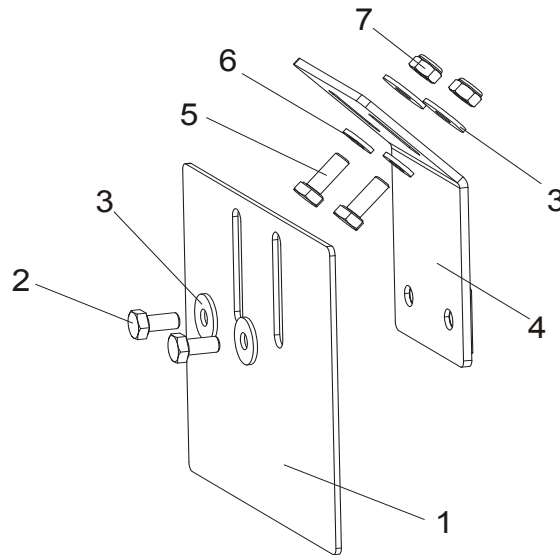

REF.	DESCRIPTION (◆ indicates parts available in assemblies only)	PART #	QTY
1	GUARD, BLADE GUIDE ROLLER	092379-1	1
2	BOLT, M6X12-8.8 HEX HEAD FULL THREAD ZINC	F81001-7	2
3	WASHER, 6.5 SPECIAL FLAT ZINC	F81053-11	4
4	BRACKET, ROLLER GUARD MOUNT	092378-1	1
5	BOLT, M6X16 8.8 HEX HEAD FULL THREAD ZINC	F81001-15	2
6	WASHER, 6.4 FLAT ZINC	F81053-1	2
7	NUT, M6-8-B HEX NYLON ZINC LOCK	F81031-2	2

3.4 Blade Guide Arm Assembly, E15

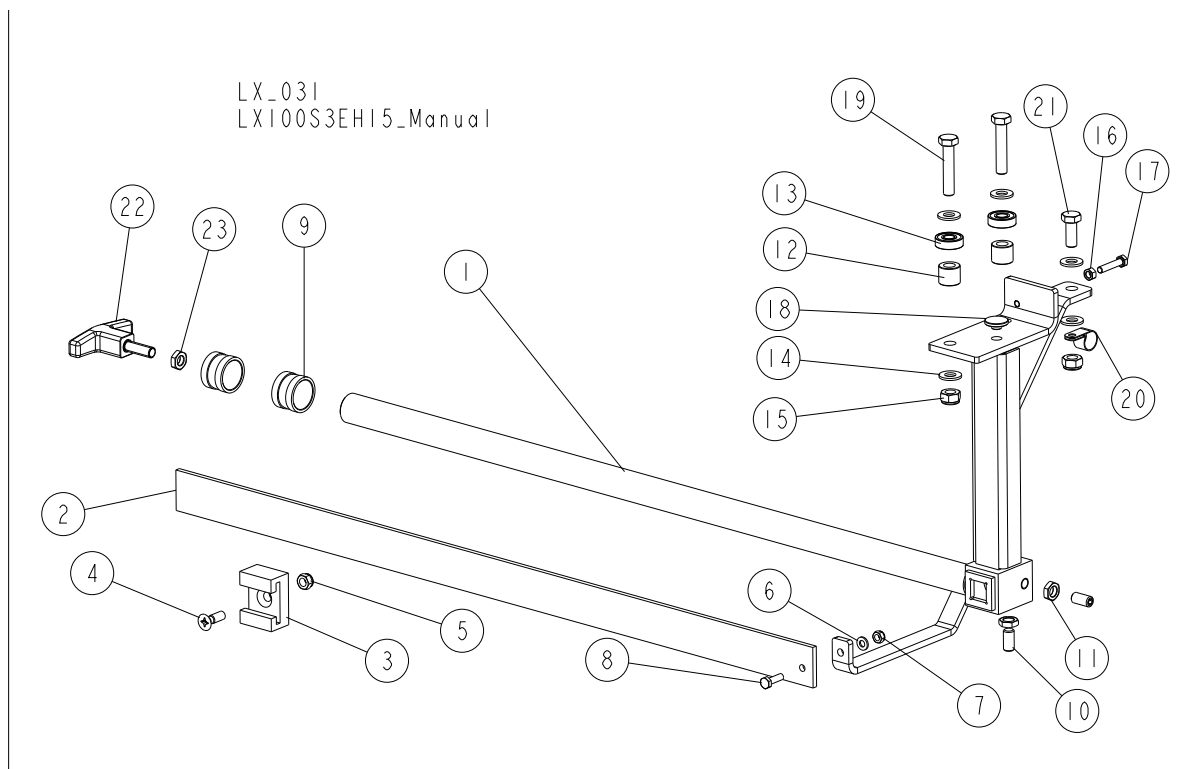

REF.	DESCRIPTION (◆ indicates parts available in assemblies only)	PART #	QTY
	ARM ASSEMBLY, BLADE GUIDE	517595	1
1	ARM, ADJUSTABLE BLADE GUIDE	517379-1	1
2	BAR, BLADE GUARD	088306	1
3	GUIDE, BLADE GUARD	088305	1
4	SCREW, M8X25 CROSS RECESSED COUNTERSUNK HEAD ZINC	F81002-51	1
5	NUT, M8 8 HEX NYLON ZINC LOCK	F81032-2	1
6	WASHER, 6.4 FLAT ZINC	F81053-1	2
7	NUT, M6-8-B HEX NYLON ZINC LOCK	F81031-2	1
8	BOLT, M6X20 8.8 HEX HEAD FULL THREAD ZINC	F81001-2	1
9	BUSHING, LT15 BLADE GUIDE	086684	2
10	SCREW, M10X1X20 DIN 913 STAINLESS STEEL SET	F81015-1	4
11	NUT, M10X1-04-ST-A2E ISO8675 THIN	F81033-10	4
12	BUSHING, 11/20-17 ZINC-PLATED	094255-1	2
13	BEARING, 6000.2RSR	087471	2
14	WASHER, 10.5 FLAT ZINC	F81055-1	6
15	NUT, M10-8-B HEX NYLON ZINC LOCK	F81033-1	3
16	NUT, M6 8 HEX ZINC	F81031-1	1
17	BOLT, M6X30-5.6 HEX HEAD FULL THREAD	F81001-13	1
18	BUSHING, BLADE GUIDE ARM	095936	1
19	BOLT, M10X50-8.8 HEX HEAD FULL THREAD ZINC	F81003-4	2
20	CLAMP, 5/8" EMT COATED	010748	1
21	BOLT, M10X25 8.8 HEX HEAD FULL THREAD ZINC	F81003-11	1
22	T-GRIP, K0180.28010X30 W/EXTERNAL THREAD	517600	1
23	NUT, M10-04-A ZINC-PLATED THIN	F81033-6	1

3.5 Blade Guide Arm w/Drive

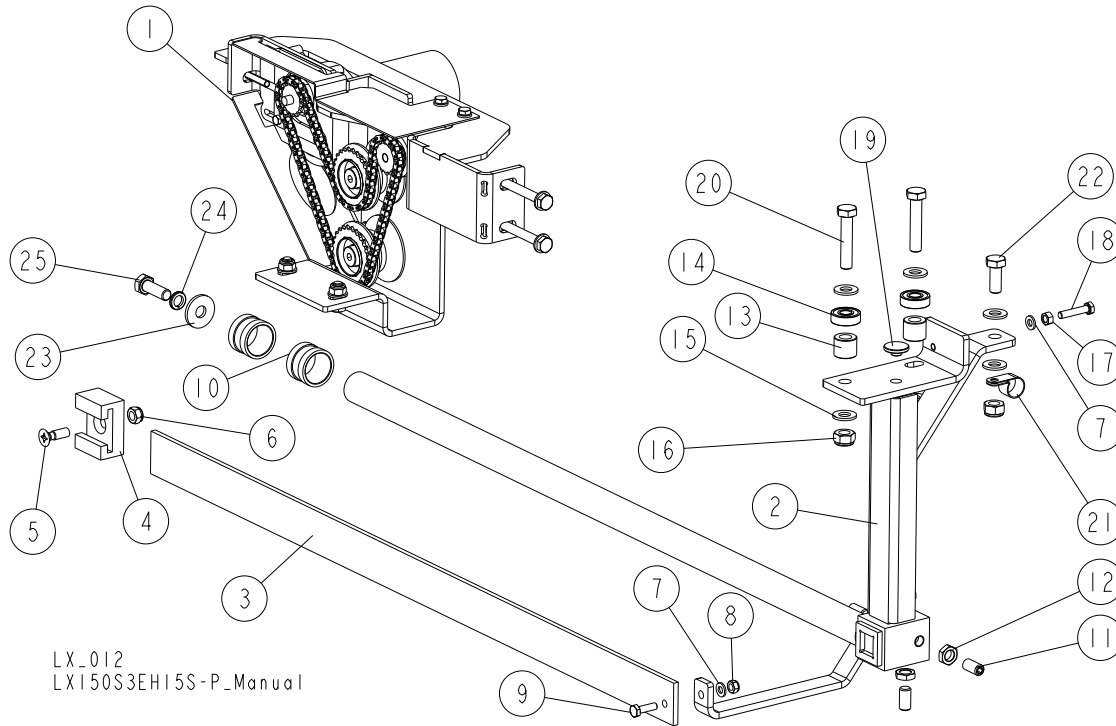

REF.	DESCRIPTION (◆ indicates parts available in assemblies only)	PART #	QTY
	ARM W/DRIVE, BLADE GUIDE	517381	1
1	DRIVE ASSEMBLY, BLADE GUIDE See Section 3.6	517270	1
	ARM ASSEMBLY, BLADE GUIDE	517380	1
2	ARM, BLADE GUIDE ADJUSTABLE	517379-1	1
3	BAR, BLADE GUARD	088306	1
4	GUIDE, BLADE GUARD	088305	1
5	SCREW, M8X25 CROSS RECESSED COUNTERSUNK HEAD ZINC	F81002-51	1
6	NUT, M8 8 HEX NYLON ZINC LOCK	F81032-2	1
7	WASHER, 6.4 FLAT ZINC	F81053-1	2
8	NUT, M6-8-B HEX NYLON ZINC LOCK	F81031-2	1
9	BOLT, M6X20 8.8 HEX HEAD FULL THREAD ZINC	F81001-2	1
10	BUSHING, BLADE GUIDE	086684	2
11	SCREW, M10X1X20 DIN 913 STAINLESS STEEL SET	F81015-1	4
12	NUT, M10X1-04-ST-A2E ISO8675 THIN	F81033-10	4
13	BUSHING, 11/20-17 ZINC-PLATED	094255-1	2
14	BEARING, 6000.2RSR	087471	2
15	WASHER, 10.5 FLAT ZINC	F81055-1	6
16	NUT, M10-8-B HEX NYLON ZINC LOCK	F81033-1	3
17	NUT, M6 8 HEX ZINC	F81031-1	1
18	BOLT, M6X30-5.6 HEX HEAD FULL THREAD	F81001-13	1
19	BUSHING, BLADE GUIDE ARM	095936	1
20	BOLT, M10X50-8.8 HEX HEAD FULL THREAD ZINC	F81003-4	2
21	CLAMP, 5/8" EMT COATED	010748	1
22	BOLT, M10X25 8.8 HEX HEAD FULL THREAD ZINC	F81003-11	1
23	WASHER, 11/30-3 ZINC-PLATED	088787-1	1

3**Blade Guide Rollers & Arm***Blade Guide Arm w/Drive*

REF.	DESCRIPTION (◆ indicates parts available in assemblies only)	PART #	QTY	
24	WASHER, Z 10.2 SPLIT LOCK ZINC	F81055-2	1	
25	BOLT, M10X30 5.8 HEX HEAD FULL THREAD ZINC	F81003-2	1	

3.6 Blade Guide Arm Drive

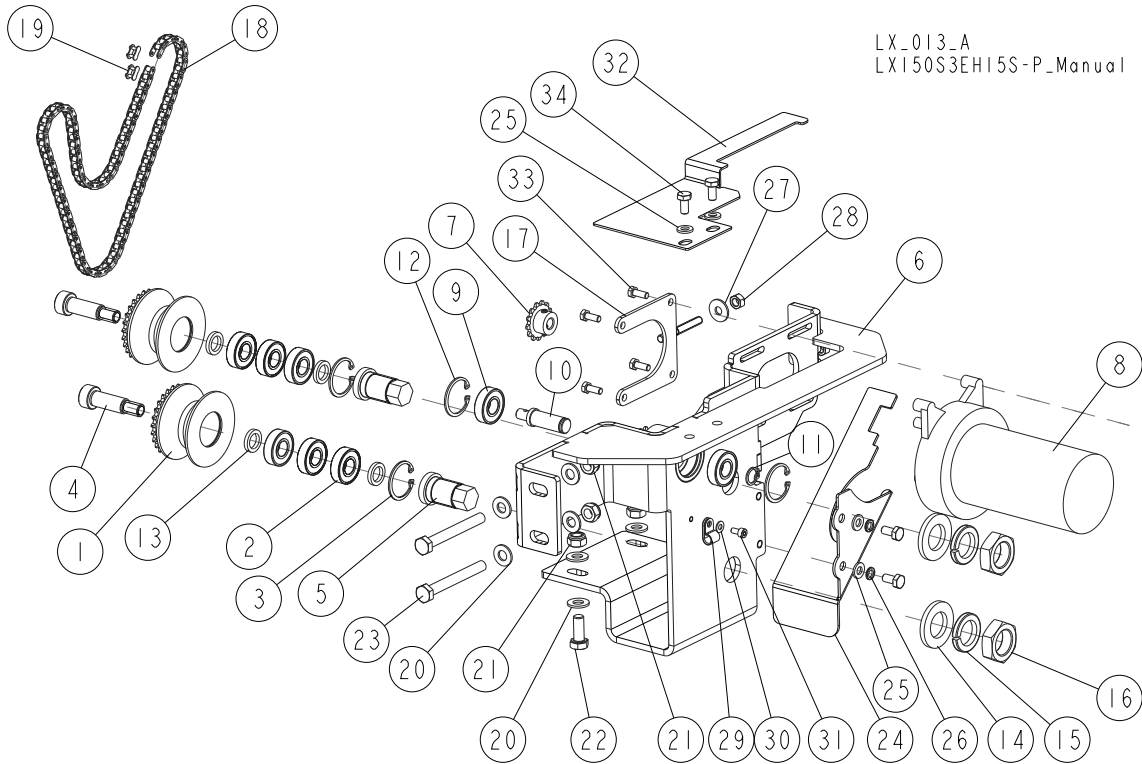

LX_013_A
LX150S3EH15S-P_Manual

REF.	DESCRIPTION (◆ indicates parts available in assemblies only)	PART #	QTY
	DRIVE ASSEMBLY, BLADE GUIDE ARM	517270	1
	COMPLETE ROLLER	517269	2
1	ROLLER W/SPROCKET	517253-1	1
2	BEARING, 6001 2RSR (FAG, SKF)	087893	3
3	RING, W28 INSIDE RETAINING	F81090-9	1
4	BOLT, 12/M10X30 12.9 ISO7379 SHOULDER	F81003-70	2
5	BOLT, ECCENTRIC	517257-1	2
6	PLATE, MOUNTING - COMPLETE	517259-1	1
7	SPROCKET, BLADE GUIDE ARM MOTOR	P09970	2
8	MOTOR, CURRENT APPLICATIONS 1/30HP 12VDC GEAR	079214	1
	Gear Kit, Motor Replacement (Current Application)	061232	1
	Brush Kit, Gear Motor Replacement (Current Application)	061234	1
	Shaft Kit, Gear Motor Replacement (Current Application)	061233	1
9	BEARING, 6001 2RSR (FAG, SKF)	087893	2
10	SHAFT, IDLER	517260	1
11	RING, Z12 OUTSIDE RETAINING	F81090-14	1
12	RING, W28 INSIDE RETAINING	F81090-9	2
13	WASHER, 12.2/18-3	517256	4
14	WASHER, 21 FLAT ZINC	F81059-2	2
15	WASHER, 20.5 SPLIT LOCK ZINC	F81059-1	2
16	NUT, M20X1.5 THIN ZINC	F81037-7	2
17	TENSIONER, DEBARKER MOTOR	089969-1	1
	CHAIN, BLADE GUIDE ARM DRIVE	517267	1
18	CHAIN, #25X98 LINKS	517266	1

REF.	DESCRIPTION (◆ indicates parts available in assemblies only)	PART #	QTY
19	LINK, 25 MASTER	P09983	2
20	WASHER, 8.4 FLAT ZINC	F81054-1	8
21	NUT, M8 8 HEX NYLON ZINC LOCK	F81032-2	4
22	BOLT, M8X20 8.8 HEX HEAD FULL THREAD ZINC	F81002-4	2
23	BOLT, M8X70-8.8 HEX HEAD ZINC	F81002-71	2
24	GUARD, CHAIN	517268-1	1
25	WASHER, 6.4 FLAT ZINC	F81053-1	4
26	WASHER, Z 6.1 SPLIT LOCK ZINC	F81053-3	2
27	WASHER, 6.5 SPECIAL FLAT ZINC	F81053-11	1
28	NUT, M6 8 HEX ZINC	F81031-1	1
29	ELEMENT, EE63 MOUNTING	F81080-4	1
30	WASHER, 4.3 FLAT ZINC	F81051-2	1
31	SCREW, M4X8 8.8 HEX SOCKET HEAD CAP ZINC	F81011-36	1
32	GUARD, UPPER	517262-1	1
33	BOLT, #10-32X1/2 HEX HEAD	F05004-60	4
34	BOLT, M6X12 8.8 HEX HEAD FULL THREAD ZINC	F81001-7	4

SECTION 4 BLADE WHEELS & TENSIONER

4.1 Blade Wheel Assembly, Drive Side (E15)

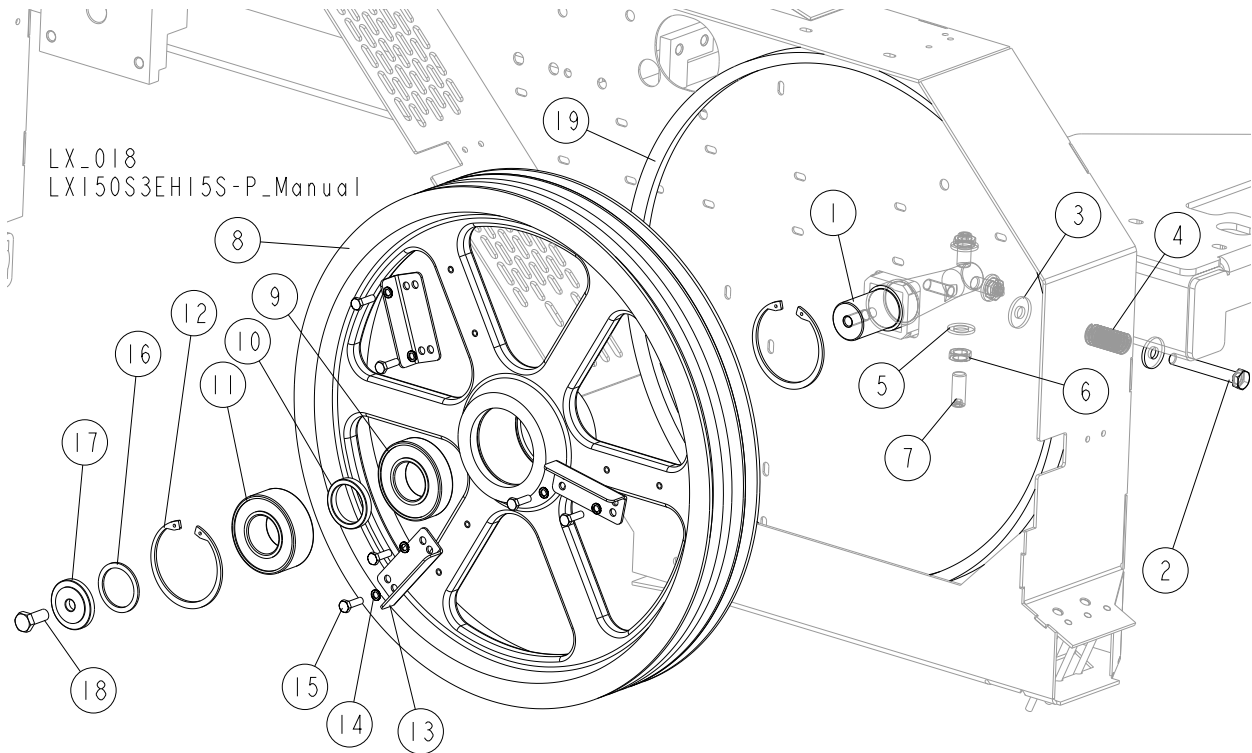

REF.	DESCRIPTION (◆ indicates parts available in assemblies only)	PART #	QTY
1	SHAFT, LT15 DRIVE SIDE BLADE WHEEL	093850	1
2	BOLT, M10X75-8.8 HEX HEAD ZINC	F81003-15	1
3	WASHER, 10.5 SPECIAL FLAT ZINC	F81055-6	2
4	SPRING, 3/4 O.D.X 1 1/2 DIE	034430	1
5	WASHER, 13 FLAT ZINC	F81056-1	3
6	NUT, M12X1.25 DIN 439 A2-70 THIN STAINLESS STEEL	F81034-9	3
7	SCREW, M12X1.25X30 DIN913 A2-70 SET	F81016-1	3
	WHEEL, DRIVE SIDE - COMPLETE	091612	1
8	WHEEL, DRIVE SIDE	090646-1	1
9	BEARING, 6207-2RS, C3, 35X72X17	014811	1
10	BUSHING, SPACER	096778	1
11	BEARING, 3207B.2RSR.TVH "FAG"	092005	1
12	RING, W72 INSIDE RETAINING	F81090-4	2
13	WING	097808-1	3
14	WASHER, Z 6.1 SPLIT LOCK ZINC	F81053-3	6
15	BOLT, M6X20 8.8 HEX HEAD FULL THREAD ZINC	F81001-2	6
16	WASHER, 36/45-2	091851	1
17	WASHER, DRIVE SIDE BLADE WHEEL	092006	1
18	BOLT, M10X25 8.8 HEX HEAD FULL THREAD ZINC	F81003-11	1
19	BELT, B57 BLADE WHEEL	P04185-2	1

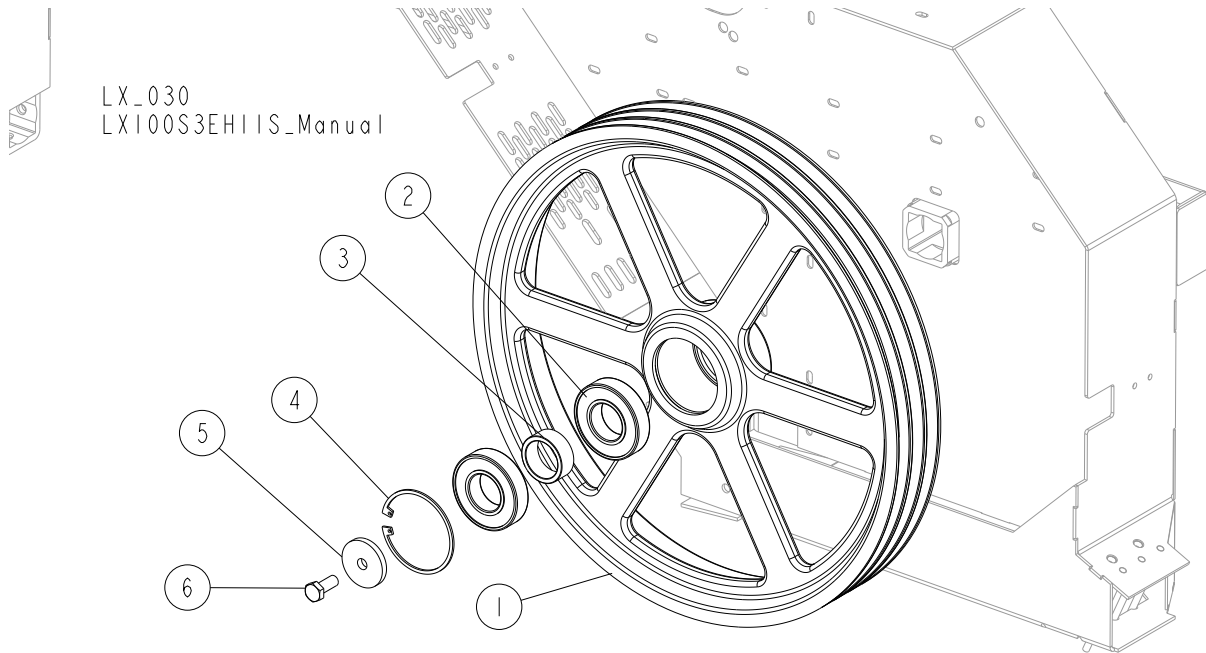
4.2 Blade Wheel Assembly, Drive Side - E11

REF.	DESCRIPTION (◆ indicates parts available in assemblies only)	PART #	QTY	
	WHEEL, LT15 DRIVE SIDE - COMPLETE	093849	1	
1	WHEEL, 19" METRIC DRIVE SIDE	096901-1	1	
2	BEARING, 6207-2RS C3 35X72X17	014811	2	
3	BUSHING, 35.5/45-17.8	093851	1	
4	RING, 72MM OD RETAINING N5002-281	F04254-30	1	
5	WASHER, 10.5/45-6 ZINC-PLATED	086286-1	1	
6	BOLT, M10X25 8.8 HEX HEAD FULL THREAD ZINC	F81003-11	1	

4.3 Blade Wheel Assembly, Idle Side

LX_019
LX150S3EH15S-P_Manual

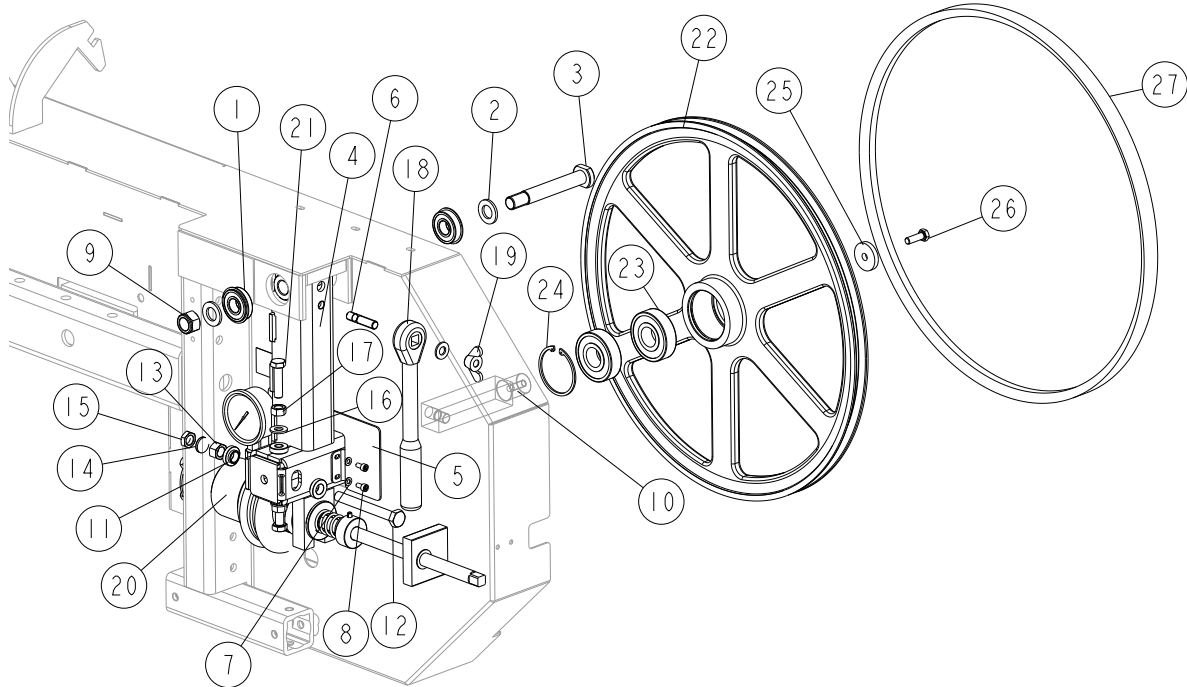

REF.	DESCRIPTION (◆ indicates parts available in assemblies only)	PART #	QTY
1	BEARING, 6203-2RS NR NSK W/SNAP RING	086395	2
2	WASHER, 17 SPLIT LOCK ZINC	F81058-1	2
3	PIN, IDLER ARM MOUNT	086404	1
	ROCKER ARM, IDLE SIDE BLADE WHEEL - COMPLETE	508145	1
4	ROCKER ARM WELDMENT, IDLE SIDE BLADE WHEEL	508144-1	1
5	GUARD, ROCKER ARM	508128-1	1
6	STUD, M10X35 8.8 ZINC-PLATED	F81003-9	1
7	WASHER, 5.3 FLAT ZINC	F81052-1	3
8	SCREW, M5X10 DIN 912 A2-70 HEX SOCKET HEAD CAP STAINLESS STEEL	F81000-23	3
9	NUT, M16-8 HEX NYLON ZINC LOCK	F81036-2	1
10	SHAFT, IDLE SIDE BLADE WHEEL	096045	1
11	WASHER, FLANGED ZINC-PLATED	086769-1	2
12	BOLT, M12X1.25X100-8.8 HEX HEAD FULL THREAD ZINC	F81004-41	1
13	NUT, M12X1.25-8-B HEX ZINC	F81034-8	1
14	WASHER, Z12.2 SPLIT LOCK ZINC	F81056-2	1
15	NUT, M12X1.25-8 THIN ZINC	F81034-5	1
16	WASHER, 10.5 FLAT ZINC	F81055-1	3
17	NUT, M10 8 HEX ZINC	F81033-3	2
18	WRENCH, LT20 BLADE TENSION	091620	1
19	NUT, M10 ZINC-PLATED WING	F81033-8	1
20	COMPLETE BLADE TENSIONER See Section 4.4	510640	1
21	BOLT, M10X40-8.8 HEX HEAD FULL THREAD ZINC	F81003-16	2
	PULLEY ASSY, 19" (482.6MM) BLADE IDLE SIDE	A08218	1

4

BLADE WHEELS & TENSIONER*Blade Wheel Assembly, Idle Side*

REF.	DESCRIPTION (◆ indicates parts available in assemblies only)	PART #	QTY	
22	SHEAVE, 18.62 IDLER	P08125	1	
23	BEARING,.9843X2.4409X.6693	P08066	2	
24	RING, 2 7/16 IR N 5002-244 BEVELED SNAP	F04254-21	1	
25	WASHER, 9/35-6 ZINC-PLATED	093854-1	1	
26	BOLT, M8X25-8.8-B HEX HEAD FULL THREAD ZINC	F81002-5	1	
27	BELT, B57 BLADE WHEEL	P04185-2	1	

4.4 Blade Tensioner Assembly

LX_020
LXI50S3EH15S-P_Manual

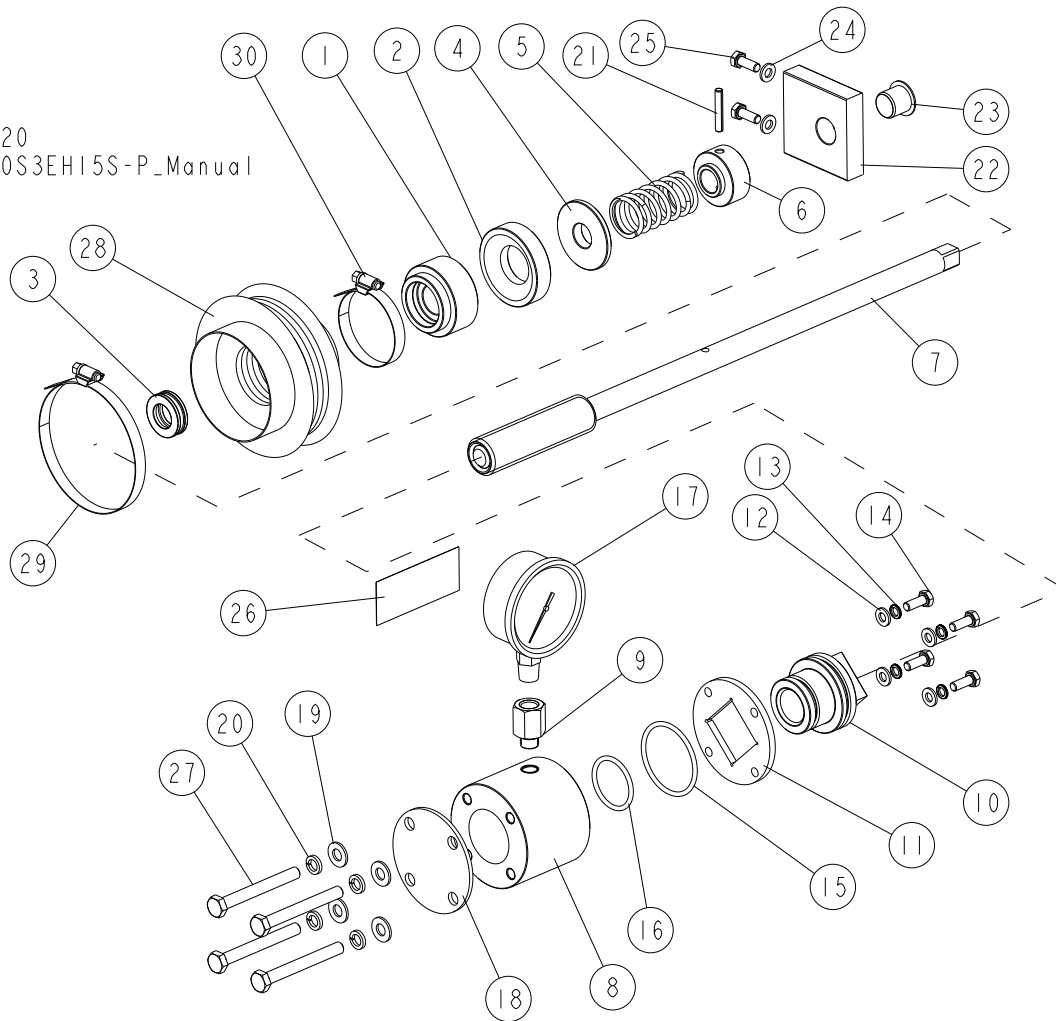

REF.	DESCRIPTION (◆ indicates parts available in assemblies only)	PART #	QTY
	BLADE TENSIONER	510640	1
1	HOUSING, BALL THRUST BEARING	510635	1
2	SOCKET, BEARING HOUSING	510634-1	1
3	BEARING, 51103 BALL THRUST	086675	1
4	WASHER	510633-1	1
5	SPRING, 60X23X3	088992	1
6	BUSHING, 16/38-20 22.5-4 ZINC-PLATED	510636-1	1
7	SCREW, BLADE TENSIONER ZINC-PLATED	510650-1	1
	COMPLETE CYLINDER	510641	1
	CYLINDER W/REDUCER FITTING	510657-1	1
8	CYLINDER	510637	1
9	FITTING, Z-M12X1/W-1/4NPT REDUCER	513280	1
10	PISTON	510638	1
11	PLATE, TENSIONER	510490-1	1
12	WASHER, 6.4 FLAT ZINC	F81053-1	4
13	WASHER, Z 6.1 SPLIT LOCK ZINC	F81053-3	4
14	BOLT, M6X16-8.8 HEX HEAD FULL THREAD ZINC	F81001-15	4

BLADE WHEELS & TENSIONER*Blade Tensioner Assembly*

REF.	DESCRIPTION (◆ indicates parts available in assemblies only)	PART #	QTY
15	O-RING, 46.2X3	510646	1
16	O-RING, 32.2X3	510647	1
17	GAUGE, 3000psi/200 bar OIL PRESSURE	505176	1
18	PLATE, CYLINDER COVER	510642-1	1
19	WASHER, 8.4 FLAT ZINC	F81054-1	4
20	WASHER, 8.2 SPLIT LOCK ZINC	F81054-4	4
21	PIN, 5X30 ROLL ZINC	F81044-21	1
22	BLOCK, TENSIONER HANDLE MOUNT	096730	1
23	BUSHING, GFM-1618-17	089589	1
24	WASHER, 6.4 FLAT ZINC	F81053-1	2
25	BOLT, M6X16-8.8 HEX HEAD FULL THREAD ZINC	F81001-15	2
26	DECAL, PRESSURE VALUES	510643	1
27	BOLT, M8X70-8.8 HEX HEAD ZINC	F81002-71	4
	COMPLETE BELLOWS	515050	1
28	BELLOWS	515051	1
29	CLAMP, 70-80 MM	F81095-5	1
30	CLAMP, 40-60 MM	F81095-4	1

SECTION 5 SAW HEAD

5.1 Blade Housing Cover

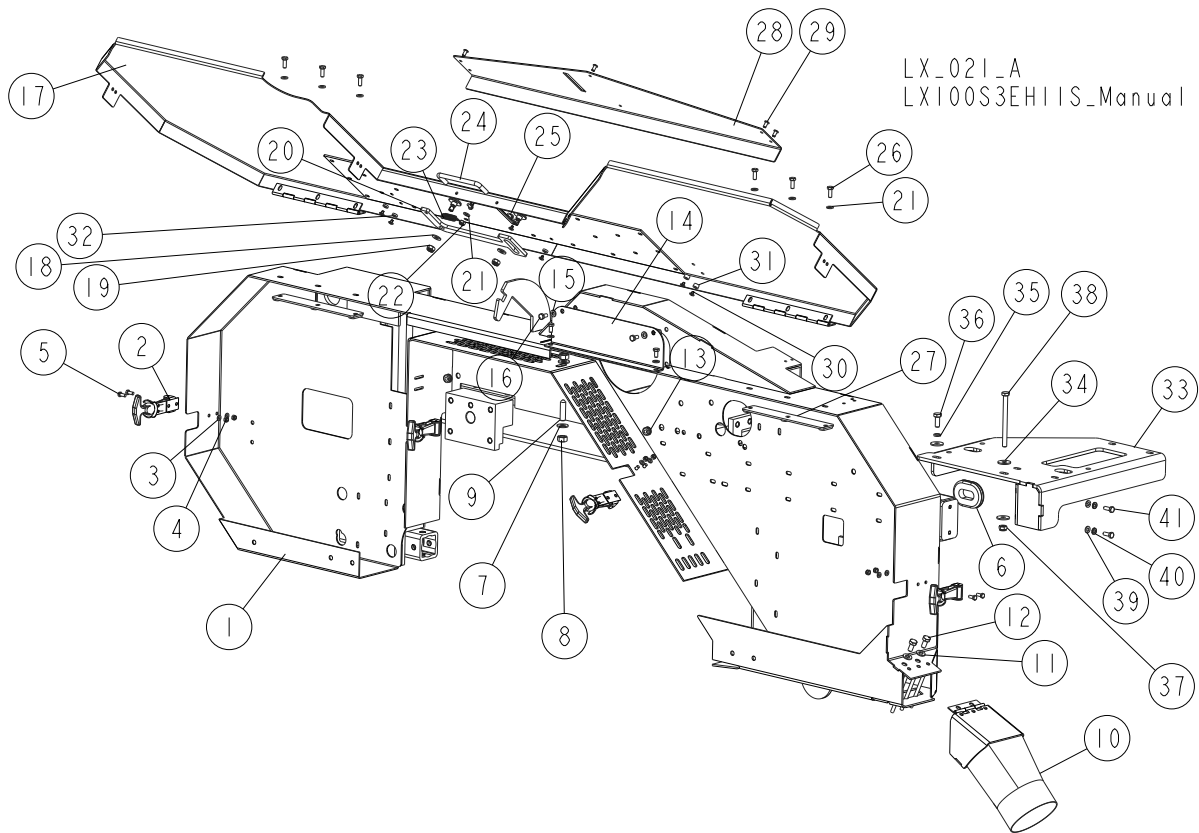

REF.	DESCRIPTION (* Indicates Parts Available In Assemblies Only)	PART #	QTY
1	SAW HEAD, LT0 AC PAINTED	097560-1	1
2	LATCH, FLEXIBLE DRAW	014829	4
3	WASHER, 5.3 FLAT ZINC	F81052-1	8
4	NUT, M5-8-FE/ZN5 DIN985	F81030-2	8
5	BOLT, M5 X 12-5.8 HEX HEAD FULL THREAD ZINC	F81000-5	8
6	GROMMET, RUBBER, 1 X 1 3/4 OVAL	085613	1
7	WASHER, 10.5 FLAT ZINC	F81055-1	2
8	NUT, M10-8-B HEX ZINC	F81033-3	2
9	SCREW, M10X40-45H CONE POINT HEX SOCKET	F81003-61	1
10	CHUTE, LT10/15/20 SAWDUST	100903-1	1
11	WASHER, 8.4 FLAT ZINC	F81054-1	2
12	BOLT, M8X16-8.8-B HEX HEAD FULL THREAD ZINC	F81002-20	2
13	SEAL WIRE, GH6	085338	2
14	PLATE, COVER	096788-1	1
15	WASHER, 6.4 FLAT ZINC	F81053-1	4
16	BOLT, M6X12-8.8 HEX HEAD FULL THREAD ZINC	F81001-7	4
	COVER, SAW HEAD FRONT	518030	1
17	COVER, SAW HEAD FRONT	518025-1	1
18	WASHER, 8.4 FLAT ZINC	F81054-1	2
19	NUT, M8-8-B HEX NYLON ZINC LOCK	F81032-2	2

REF.	DESCRIPTION (* Indicates Parts Available In Assemblies Only)	PART #	QTY	
20	PAWL, LOCKING	090643-1	1	
21	WASHER, 6.4 FLAT ZINC	F81053-1	8	
22	NUT, M6-8-B HEX NYLON ZINC LOCK	F81031-2	1	
23	SPRING, 1.6X12X38 EXTENSION	092208	1	
24	HANDLE, 4" W/BOLTS	P08065	1	
25	BOLT, #8-32X3/8 SELF-TAPPING	F05015-8	2	
26	BOLT, M6 X 16 8.8 HEX HEAD FULL THREAD ZINC	F81001-15	6	
27	PLATE WELDMENT, COVER MOUNTING	086701-1	2	
28	PLATE, DECORATIVE	518029-1	1	
29	SCREW, 1918 DIA. BINDING (FEMALE PART - 10 MM LONG)	518033	6	
30	SCREW, 1918 DIA. BINDING (MALE PART - 6 MM LONG)	518034	6	
31	BUSHING, 1941 DIA. (5.2/10-6) SPACER	518159	2	
32	WASHER, 1940 DIA. (5.2/10-3)	518158	4	
	PLATE , MOUNTING COMPLETE	518165	1	
33	PLATE, MOUNTING	518164-1	1	
34	WASHER, ISO 7093-1-8-200 HV-A2E	F81054-11	3	
35	WASHER, 8.2 ZINC-PLATED	F81054-4	1	
36	BOLT, M8X20-5.8 HEX HEAD FULL THREAD ZINC	F81002-1	1	
37	NUT, M8-8-B HEX NYLON ZINC LOCK	F81032-2	1	
38	BOLT, M8 X 100-8.8 HEX HEAD ZINC	F81002-23	1	
39	WASHER, 6.4 FLAT ZINC	F81053-1	2	
40	WASHER, 6.1 DIN 127 (A2-304) STAINLESS STEEL SPRING	F81053-4	2	
41	BOLT, M6 X 16 8.8 HEX HEAD FULL THREAD ZINC	F81001-15	2	

5.2 Water Lube Assembly

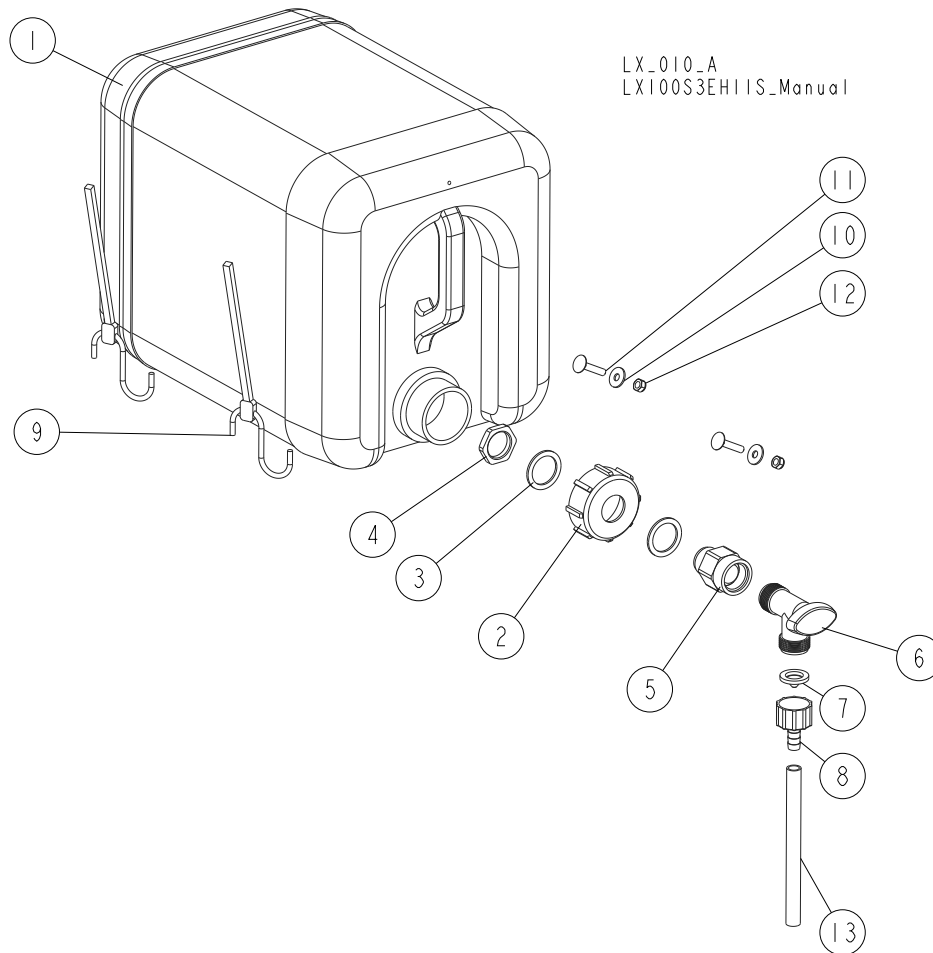

REF.	DESCRIPTION (* Indicates Parts Available In Assemblies Only)	PART #	QTY
	BOTTLE ASSEMBLY, WATER	517110	1
	BOTTLE, WATER - COMPLETE	513864	1
	WATER BOTTLE WITH NUT	513865	1
1	BOTTLE, WATER	513866	1
2	NUT, WATER BOTTLE	513867	1
3	SEAL, 35x26x2 RUBBER	513869	2
4	GLAND NUT, 3/4 NPT 467616	513868	1
5	FITTING, 3/4FPTX3/4MPT	014636	1
6	VALVE, 3/4 NPT ELBOW 3/4 MALE OUTLET PVC	014100	1
7	FILTER, WATER LUBE	016086	1
8	REDUCER, 5/8NPT/3/8BARB WATER LUBE	014113	1
9	STRAP, 24 IN RUBBER WITH HOOKS	P11258	2
10	WASHER, 6.5 SPECIAL FLAT ZINC	F81053-11	2
11	BOLT, M6X30-8.8 CARRIAGE HEAD ZINC	F81001-59	2
12	NUT, M6-8-B HEX NYLON ZINC LOCK	F81031-2	2
13	TUBING, WATER LUBE	R01885	1

5.3 Slide Pads

LX_022_A
LX100S3EH11S_Manual

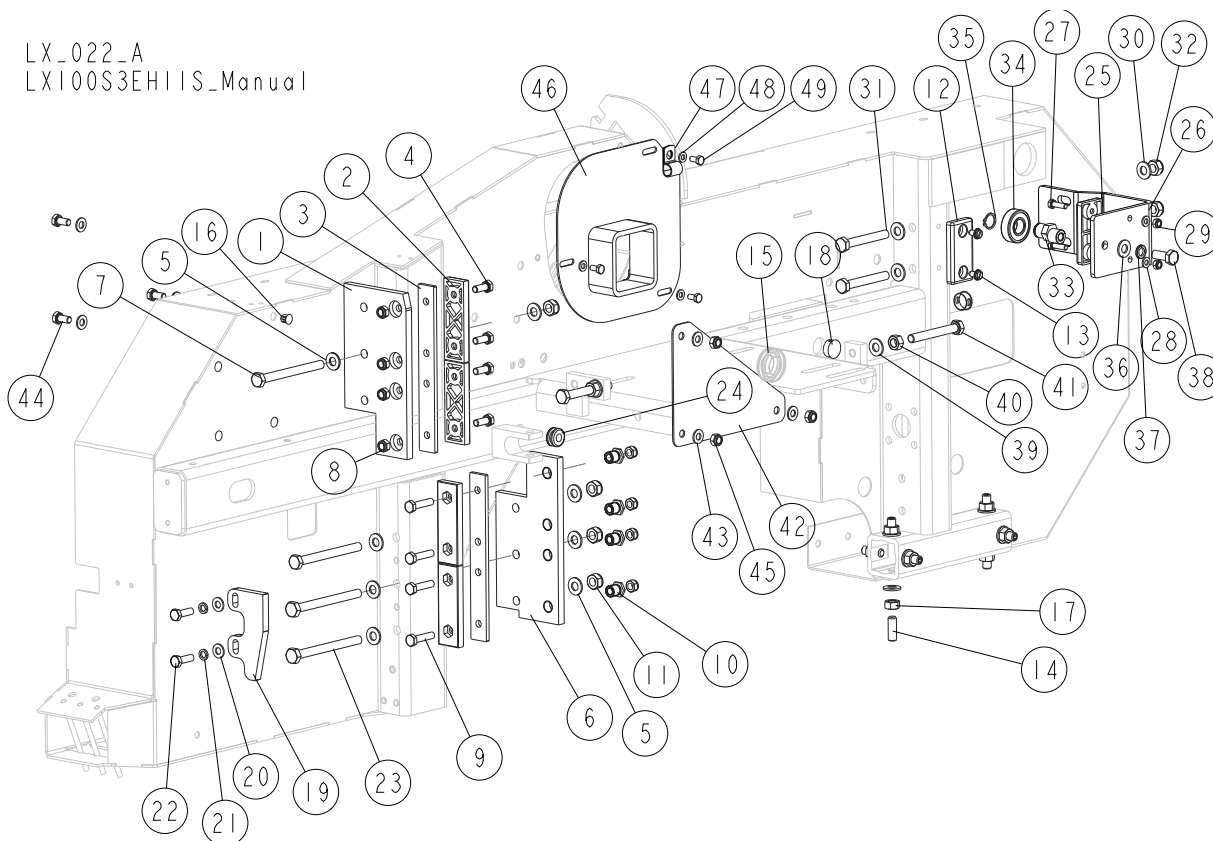

REF.	DESCRIPTION (* Indicates Parts Available in Assemblies Only)	PART #	QTY
1	PLATE, SAW HEAD UPPER GUIDE	094139-1	1
2	PADS, DELRIN UP/DOWN SLIDE	M04096	4
3	PLATE, SLIDE PAD SPACER	094140-1	2
4	BOLT, M8X20-8.8-B HEX HEAD FULL THREAD ZINC	F81002-4	4
5	WASHER, 10.5 FLAT ZINC	F81055-1	16
6	PLATE, SAW HEAD LOWER ZINC-PL. GUIDE	086682-1	1
7	BOLT, M10X110-8.8 HEX HEAD ZINC	F81003-43	2
8	NUT, M8-8-B HEX NYLON ZINC LOCK	F81032-2	8
9	BOLT, M8X35-8.8 HEX HEAD FULL THREAD ZINC	F81002-13	4
10	NUT, LT15 SLIDE PAD ADJUSTMENT ZINC-PLATED	086683-1	4
11	NUT, M10-8-B HEX NYLON ZINC LOCK	F81033-1	4
12	PAD, CATAPILLAR TRACK	P13576	1
13	SCREW, 1/4-20X1/2" TYPE "23" SELF-TAPPING	F05015-1	2
14	SCREW, M10X30-33H-GEOMET HEX SOCKET SET FLAT POINT	F81003-35	8
15	GROMMET, 22MM I.D. RUBBER	087400	1
16	PLUG, SR1086-9.5 NO. 46009 (MOSS) 096846 4	096846	4
17	NUT, M10-8-B HEX ZINC	F81033-3	8
18	PLUG, 20.6 HEYMAN DP-812 HOLE	086811	3
	PLATE, LIMIT SWITCH ACTIVATOR - COMPLETE	516510	1
19	PLATE, LIMIT SWITCH ACTIVATOR	516509-1	1
20	WASHER, 8.4 FLAT ZINC	F81054-1	2
21	WASHER, 8.2 SPLIT LOCK ZINC	F81054-4	2

REF.	DESCRIPTION (* Indicates Parts Available In Assemblies Only)	PART #	QTY
22	BOLT, M8X25-8.8-B HEX HEAD FULL THREAD ZINC	F81002-5	2
23	BOLT, M10 X 115-8.8 HEX HEAD ZINC	F81003-19	2
24	GROMMET, RUBBER 3/8 ID	025248	1
	BRACKET, RIGHT SLIDE PAD - COMPLETE	518170	1
25	PAD, CATAPILLAR TRACK	P13576	1
26	BRACKET, UPPER	518183-1	1
27	BOLT, M6X20-8.8 HEX HEAD FULL THREAD ZINC	F81001-2	2
28	WASHER, 6.4 FLAT ZINC	F81053-1	2
29	NUT, M6-8-B HEX NYLON ZINC LOCK	F81031-2	2
30	WASHER, 10.5 FLAT ZINC	F81055-1	4
31	BOLT, M10X75-8.8 HEX HEAD ZINC	F81003-15	2
32	NUT, M10-8-B HEX NYLON ZINC LOCK	F81033-1	2
	ROLLER ASSEMBLY, ECCENTRIC	518182	1
33	SHAFT, OUTER ECCENTRIC E=3.3-ZINC-PL.	098898-1	1
34	BEARING, 6203-2RS	086114	1
35	RING, Z17 OUTSIDE RETAINING	F81090-21	1
36	WASHER, 10.5 FLAT ZINC	F81055-1	1
37	WASHER, 10.2 SPLIT LOCK ZINC	F81055-2	1
38	BOLT, M10X25-8.8 HEX HEAD FULL THREAD ZINC	F81003-11	1
39	WASHER, 10.5 FLAT ZINC	F81055-1	2
40	NUT, M10-8-B HEX ZINC	F81033-3	2
41	BOLT, M10-80-8.8 HEX HEAD FULL THREAD ZINC	F81003-76	2
42	CAP, BOLTED	094247-1	1
43	WASHER, 8.4 FLAT ZINC	F81054-1	6
44	BOLT M8X16-8.8-B HEX HEAD FULL THREAD ZINC	F81002-20	3
45	NUT, M8-8-B HEX NYLON ZINC LOCK	F81032-2	3
46	GUARD, E11/E15 MOTOR SHAFT	095335-1	1
47	CLAMP, 1/2EMT COATED	P07584	1
48	WASHER, 6.4 FLAT ZINC	F81053-1	3
49	BOLT, M6X12-8.8 HEX HEAD FULL THREAD ZINC	F81001-7	3

5.4 Saw Head Decals

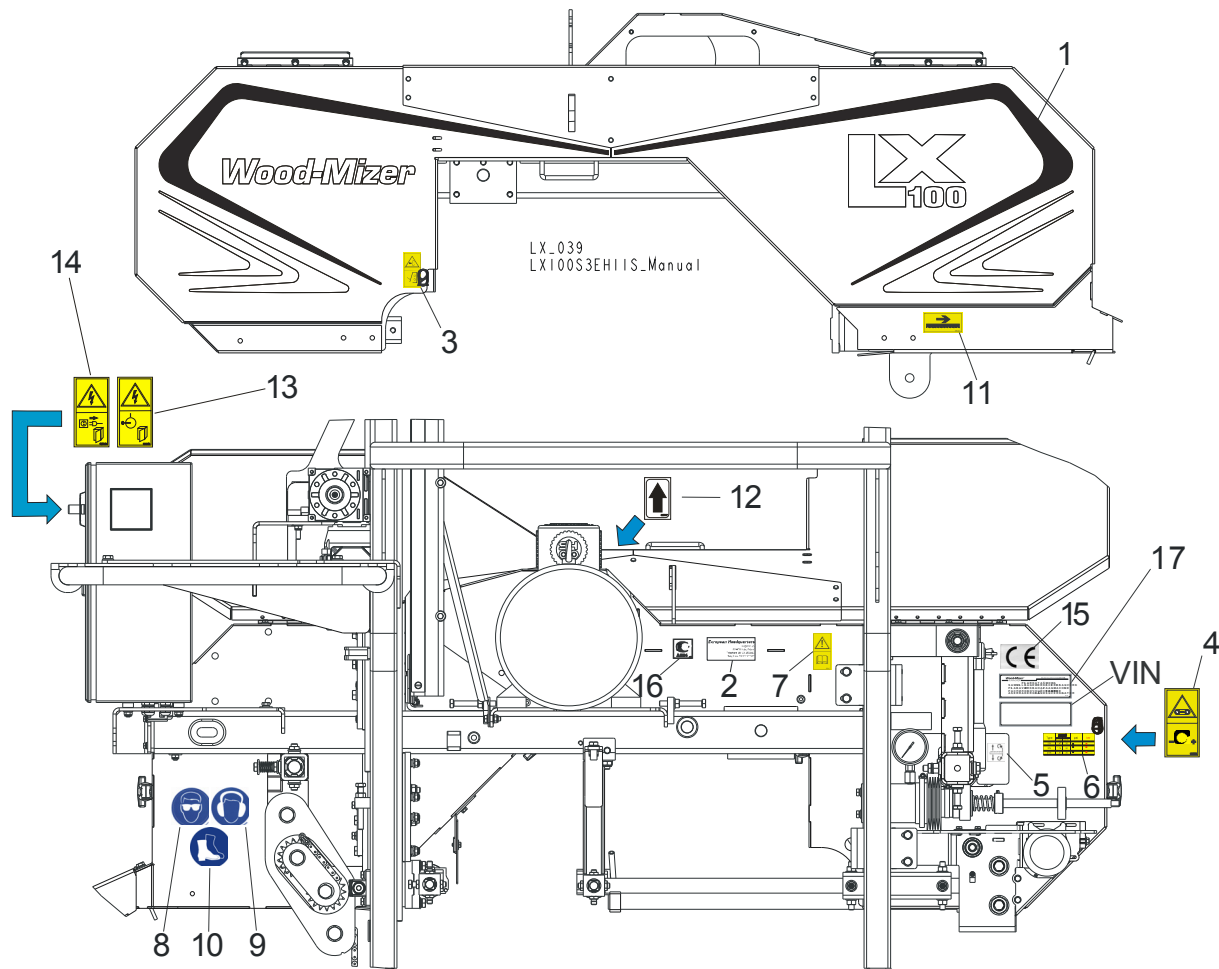

REF.	DESCRIPTION (◆ indicates parts available in assemblies only)	PART #	QTY
	PICTOGRAPHIC DECAL KIT	518619	1
	DECAL, SERIES SAWMILL	518620	1
1	DECAL, EUROPEAN HEADQUARTERS ADDRESS	015841	1
2	DECAL, SAWMILL COVERS CAUTION	099220	1
3	DECAL, BLADE TENSION (PICTOGRAM)	099219	1
4	DECAL, BLADE ALIGNMENT	P11789	1
5	DECAL, TENSIONER PRESSURE VALUE	510643	1
6	DECAL, READ OPERATOR'S MANUAL (PICTOGRAM)	096317	1
7	DECAL, EYE WARNING (PICTOGRAM)	S12004G	1
8	DECAL, EAR WARNING (PICTOGRAM)	S12005G	1
9	DECAL, USE SAFETY BOOTS (PICTOGRAM)	501465	1
10	DECAL, BLADE MOVEMENT DIRECTION (PICTOGRAM)	096321	1
11	DECAL, MOTOR DIRECTION	S20097	1
12	DECAL, HIGH VOLTAGE IN ELECTRIC BOX	096316	1
13	DECAL, DISCONNECT POWER SUPPLY BEFORE OPENING	096319	1
14	DECAL, CE CERTIFIED MACHINE [SMALL]	P85070	1
15	DECAL, RUSSIAN SAFETY CERTIFICATION	099401	1
16	DECAL, INTERNATIONAL SAWMILL NAME	501466	1

SECTION 6 SAWMILL MAST

6.1 EH11S Mast and Up/Down Limit Switches

LX_026_B
 LX100S3EH11S_Manual

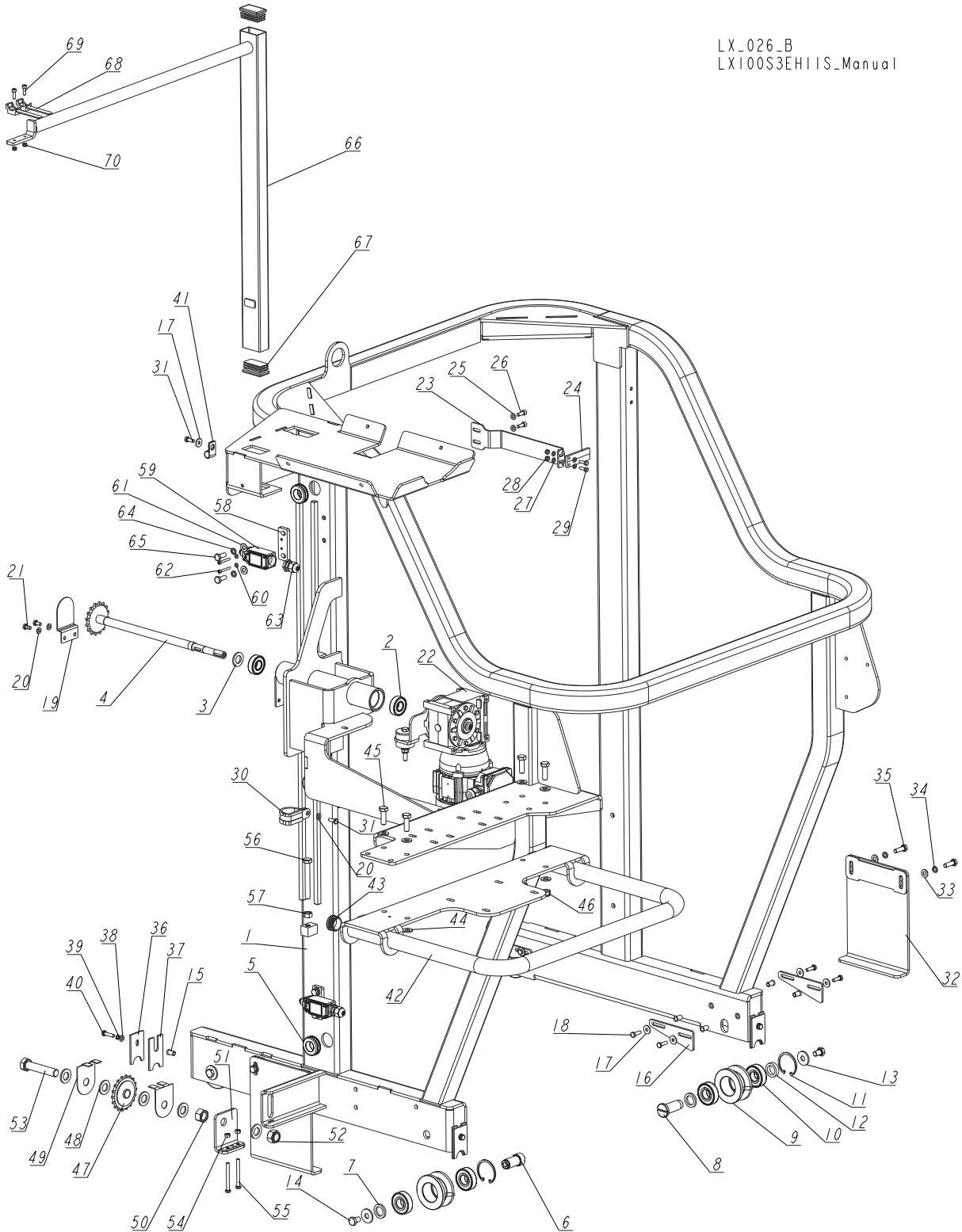

REF.	DESCRIPTION (* Indicates Parts Available in Assemblies Only)	PART #	QTY
	MAST, CE - COMPLETE	516093	1
	MAST, CE	516092-1	1
1	MAST WELDMENT, CE	516091	1
2	BEARING, 6203-2RS	086114	2
3	WASHER, 17 FLAT ZINC	F81058-1	1
4	SHAFT WITH SPROCKET	513307	1
5	GROMMET, 22 MM ID RUBBER	087400	3
6	PIN, FIXED TRACK ROLLER	515018	2
7	WASHER, 20.5X30-4, ZINCK	515021-1	4
8	PIN, ADJUSTABLE ROLLER	515101	2
	ROLLER ASSEMBLY, TRACK	515015	4
9	ROLLER	514889	1
10	BEARING, 6204 2RS-CX ROLLING	088447	2
11	RING, W47 INSIDE RETAINING	089653	1
12	WASHER, 20.5X30-7.4 ZINC	518177-1	2
13	WASHER, 11 SPECIAL FLAT ZINC	088787-1	4
14	BOLT, M10X16-8.8 HEX HEAD FULL THREAD ZINC	F81003-13	4
15	NUT, M6 1.5-4.0 STAINLESS STEEL RIVET	F81031-9	12
16	PLATE, ROLLER ADJUSTMENT	516508-1	4
17	WASHER, 6.5 SPECIAL FLAT ZINC	F81053-11	9
18	BOLT, M6X20-8.8 HEX HEAD FULL THREAD ZINC	F81001-2	8
19	GUARD, LT15 UPPER SAW HEAD SPROCKET	092567-1	1
20	WASHER, 6.4 FLAT ZINC	F81053-1	3
21	BOLT, M6X12-8.8 HEX HEAD FULL THREAD ZINC	F81001-7	2
22	DRIVE ASSEMBLY, UP/DOWN See Section 8.1	517395	1
	INDICATOR, BLADE HEIGHT SCALE - COMPLETE	517399	1
23	INDICATOR, BLADE HEIGHT SCALE - COMPLETE	517382-1	1
24	INDICATOR, BLADE HEIGHT SCALE	094821	1
25	WASHER, 6.4 FLAT ZINC	F81053-1	2
26	SCREW, M6X16 HEX SOCKET HEAD CAP	F81001-21	2
27	WASHER, 5.3 FLAT ZINC	F81052-1	4
28	NUT, M5-8-FE/ZN5 DIN985	F81030-2	2
29	BOLT, M5X16-8.8 HEX HEAD FULL THREAD ZINC	F81000-20	2
30	CLAMP, RSGU 1.30/20	F81087-1	1
31	BOLT, M6 X 16 8.8 HEX HEAD FULL THREAD ZINC	F81001-15	2
	COMPLETE PLATE	517608	1
32	PLATE WELDMENT	517605-1	1
33	WASHER, 8.4 FLAT ZINC	F81054-1	2
34	WASHER 8.2 SPLIT LOCK ZINC	F81054-4	2
35	BOLT, M8X25-8.8-B HEX HEAD FULL THREAD ZINC	F81002-5	2
	COMPLETE SCRAPER	517611	4
36	PLATE, SCRAPER CLAMPING	517610-1	1
37	SCRAPER	517609	1
38	WASHER, 6.4 FLAT ZINC	F81053-1	1
39	WASHER, Z 6.1 SPLIT LOCK ZINC	F81053-3	1
40	BOLT, M6x25 -5.8 HEX HEAD FULL THREAD ZINC	F81001-3	1
41	CLAMP, 1/2EMT COATED	P07584	1

REF.	DESCRIPTION (* Indicates Parts Available In Assemblies Only)	PART #	QTY
	HANDLE, CE - COMPETE	517612	1
42	HANDLE WELDMENT, CE	517557-1	1
43	CAP, SR1530 (30 HOLE) TUBE	517616	1
44	WASHER, 10.5 FLAT ZINC	F81055-1	8
45	BOLT, M10X30-5.8 HEX HEAD FULL THREAD ZINC	F81003-2	4
46	NUT, M10-8-B HEX NYLON ZINC LOCK	F81033-1	4
	SPROCKET ASSEMBLY, BOTTOM	518175	1
47	SPROCKET, #40 IDLER 17T 5/8ID	P04333	1
48	WASHER, 17 FLAT ZINC	F81058-1	5
49	GUARD, LT15 UP/DOWN CHAIN SPROCKET	092566-1	2
50	NUT, M16-5.8 HEX ZINC	F81036-1	1
51	TENSIONER	502525-1	1
52	NUT, M16-8 HEX NYLON ZINC LOCK	F81036-2	1
53	BOLT, M16X80 8.8-B HEX HEAD FULL THREAD ZINC	F81006-11	1
54	NUT, M6-8 HEX ZINC	F81031-1	2
55	BOLT, M6X60-8.8 HEX HEAD FULL THREAD ZINNC	F81001-9	2
56	BOLT, M10-80-8.8 HEX HEAD FULL THREAD ZINC	F81003-76	1
57	NUT, M10-8-B HEX ZINC	F81033-3	1
	LIMIT SWITCH W/MOUNTING PLATE	094227	2
58	PLATE, LIMIT SWITCH MOUNT	094228-1	1
59	SWITCH, FA134 Z11 SAFETY	100910	1
60	WASHER 4,3 FLAT ZINC	F81051-2	2
61	WASHER, 8.4 FLAT ZINC	F81054-1	2
62	SCREW, M4X30-8.8 DIN 912 HEX SOCKET HEAD CAP ZINC	F81000-85	2
63	GLAND, DP9/H CABLE	F81096-2	1
64	WASHER 8.2 SPLIT LOCK ZINC	F81054-4	2
65	BOLT, M8X20-8.8-B HEX HEAD FULL THREAD ZINC	F81002-4	2
	HANGER, LT15 POWER CORD	097449	1
66	BRACKET, LT15 POWER CORD	086132-1	1
67	CAP, 50X30 BLACK	095919	2
68	HOLDER - PLASTIC CABLE TIE	F81082-1	2
69	SCREW, M5X16-8.8 HEX SOCKET HEAD CAP ZINC	F81000-25	2
70	NUT, M5-8-FE/ZN5 DIN985	F81030-2	2

6.2 Handle for Manual Feed

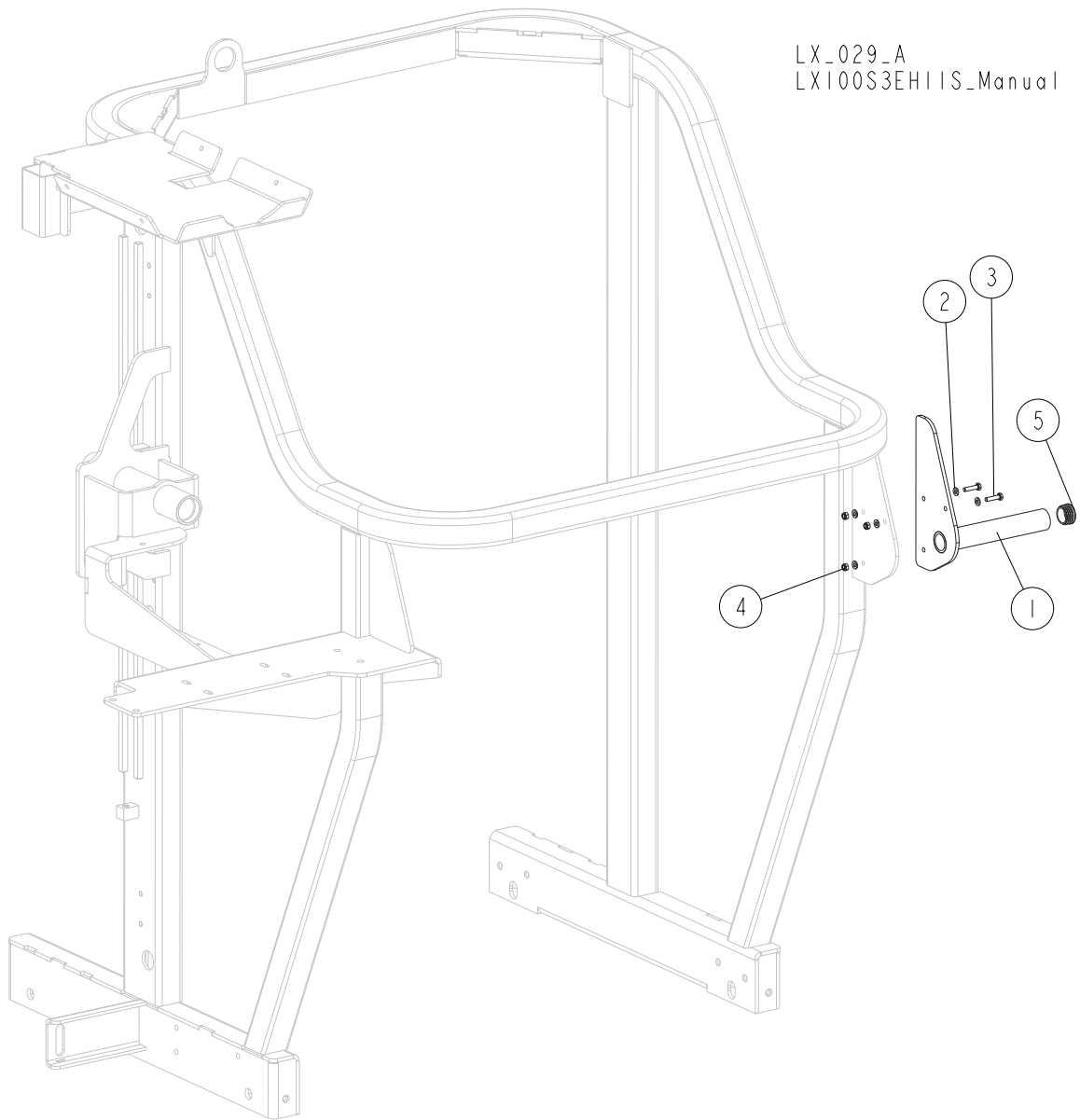

REF.	DESCRIPTION (◆ indicates parts available in assemblies only)	PART #	QTY
	HANDLE, ADDITIONAL - COMPLETE	516821	1
1	HANDLE WELDMENT	516820-1	1
2	WASHER, 6.4 FLAT ZINC	F81053-1	6
3	BOLT, M6X25 5.8 HEX HEAD FULL THREAD ZINC	F81001-3	3
4	NUT, M6-8-B HEX NYLON ZINC LOCK	F81031-2	3
5	CAP, SR1530 (30 HOLE) TUBE	517616	1

6.3 E15 Sawmill Mast (African Version)

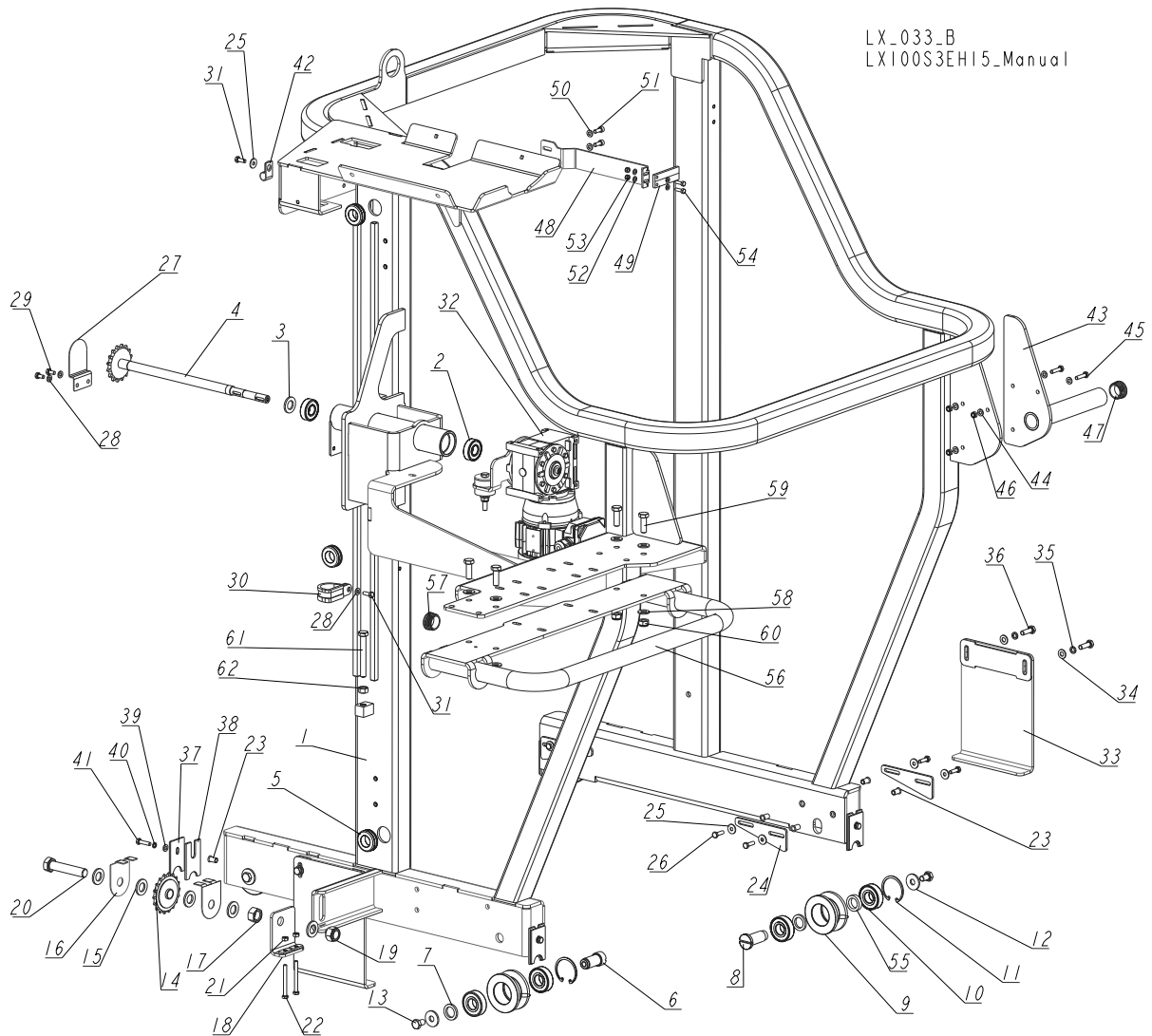

REF.	DESCRIPTION (* Indicates Parts Available in Assemblies Only)	PART #	QTY
	MAST, COMPLETE	517385	1
	MAST	516092-1	1
1	MAST WELDMENT	516091	1
2	BEARING, 6203-2RS	086114	2
3	WASHER, 17 FLAT ZINC	F81058-1	1
4	SHAFT WITH SPROCKET	513307	1
5	GROMMET, 22 MM ID RUBBER	087400	3
6	PIN, FIXED TRACK ROLLER	515018	2
7	WASHER, 20.5X30-4, ZINC	515021-1	4
8	PIN, ADJUSTABLE ROLLER	515101	2
	ROLLER ASSEMBLY, TRACK	515015	4
9	ROLLER	514889	1
10	BEARING, 6204 2RS-CX ROLLING	088447	2
11	RING, W47 INSIDE RETAINING	089653	1

REF.	DESCRIPTION (* Indicates Parts Available In Assemblies Only)	PART #	QTY
12	WASHER, 11 ZINC FLAT SPECIAL	088787-1	4
13	BOLT, M10X16-8.8 HEX HEAD FULL THREAD ZINC	F81003-13	4
	SPROCKET ASSEMBLY, BOTTOM	518175	1
14	SPROCKET, #40 IDLER 17T 5/8ID	P04333	1
15	WASHER, 17 FLAT ZINC	F81058-1	5
16	GUARD, LT15 UP/DOWN CHAIN SPROCKET	092566-1	2
17	NUT, M16-5.8 HEX ZINC	F81036-1	1
18	TENSIONER	502525-1	1
19	NUT, M16-8 HEX NYLON ZINC LOCK	F81036-2	1
20	BOLT, M16X80 8.8-B HEX HEAD FULL THREAD ZINC	F81006-11	1
21	NUT, M6-8 HEX ZINC	F81031-1	2
22	BOLT, M6X60-8.8 HEX HEAD FULL THREAD ZINC	F81001-9	2
23	NUT, M6 1.5-4.0 STAINLESS STEEL RIVET	F81031-9	12
24	PLATE, ROLLER ADJUSTMENT	516508-1	4
25	WASHER, 6.5 SPECIAL FLAT ZINC	F81053-11	9
26	BOLT, M6X20-8.8 HEX HEAD FULL THREAD ZINC	F81001-2	8
27	GUARD, UPPER LT15 SAW HEAD SPROCKET	092567-1	1
28	WASHER, 6.4 FLAT ZINC	F81053-1	3
29	BOLT, M6X12-8.8 HEX HEAD FULL THREAD ZINC	F81001-7	2
30	CLAMP, RSGU 1.30/20	F81087-1	1
31	BOLT, M6 X 16 8.8 HEX HEAD FULL THREAD ZINC	F81001-15	2
32	DRIVE ASSEMBLY, UP/DOWN See Section 8.1	517395	1
	COMPLETE PLATE	517608	1
33	PLATE WELDMENT	517605-1	1
34	WASHER, 8.4 FLAT ZINC	F81054-1	2
35	WASHER 8.2 SPLIT LOCK ZINC	F81054-4	2
36	BOLT, M8X25-8.8-B HEX HEAD FULL THREAD ZINC	F81002-5	2
	COMPLETE SCRAPER	517611	4
37	PLATE, SCRAPER CLAMPING	517610-1	1
38	SCRAPER	517609	1
39	WASHER, 6.4 FLAT ZINC	F81053-1	1
40	WASHER, Z 6.1 SPLIT LOCK ZINC	F81053-3	1
41	BOLT, M6x25-5.8 HEX HEAD FULL THREAD ZINC	F81001-3	1
42	CLAMP, 1/2EMT COATED	P07584	1
	HANDLE, ADDITIONAL - COMPLETE	516821	1
43	HANDLE WELDMENT	516820-1	1
44	WASHER, 6.4 FLAT ZINC	F81053-1	6
45	BOLT, M6X25 5.8 HEX HEAD FULL THREAD ZINC	F81001-3	3
46	NUT, M6-8-B HEX NYLON ZINC LOCK	F81031-2	3
47	CAP, SR1530 (30 HOLE) TUBE	517616	1
	INDICATOR, BLADE HEIGHT SCALE - COMPLETE	517399	1
48	INDICATOR, BLADE HEIGHT SCALE - COMPLETE	517382-1	1
49	INDICATOR, BLADE HEIGHT SCALE	094821	1
50	WASHER, 6.4 FLAT ZINC	F81053-1	2
51	SCREW, M6X16 HEX SOCKET HEAD CAP	F81001-21	2
52	WASHER, 5.3 FLAT ZINC	F81052-1	4
53	NUT, M5-8-FE/ZN5 DIN985	F81030-2	2

REF.	DESCRIPTION (* Indicates Parts Available In Assemblies Only)	PART #	QTY	
54	BOLT, M5X16-8.8 HEX HEAD FULL THREAD ZINC	F81000-20	2	
55	WASHER, 20.5X30-7.4 ZINC	518177-1	2	
	COMPLETE HANDLE (AFRICA)	518166	1	
56	HANDLE WELDMENT (AFRICA)	518167-1	1	
57	CAP, SR1530 (30 HOLE) TUBE	517616	1	
58	WASHER, 10.5 FLAT ZINC	F81055-1	8	
59	BOLT, M10x30-5.8 HEX HEAD FULL THREAD ZINC	F81003-2	4	
60	NUT, M10-8-B HEX NYLON ZINC LOCK	F81033-1	4	
61	BOLT, M10-80-8.8 HEX HEAD FULL THREAD ZINC	F81003-76	1	
62	NUT, M10-8-B HEX ZINC	F81033-3	1	

6.4 EC Mast

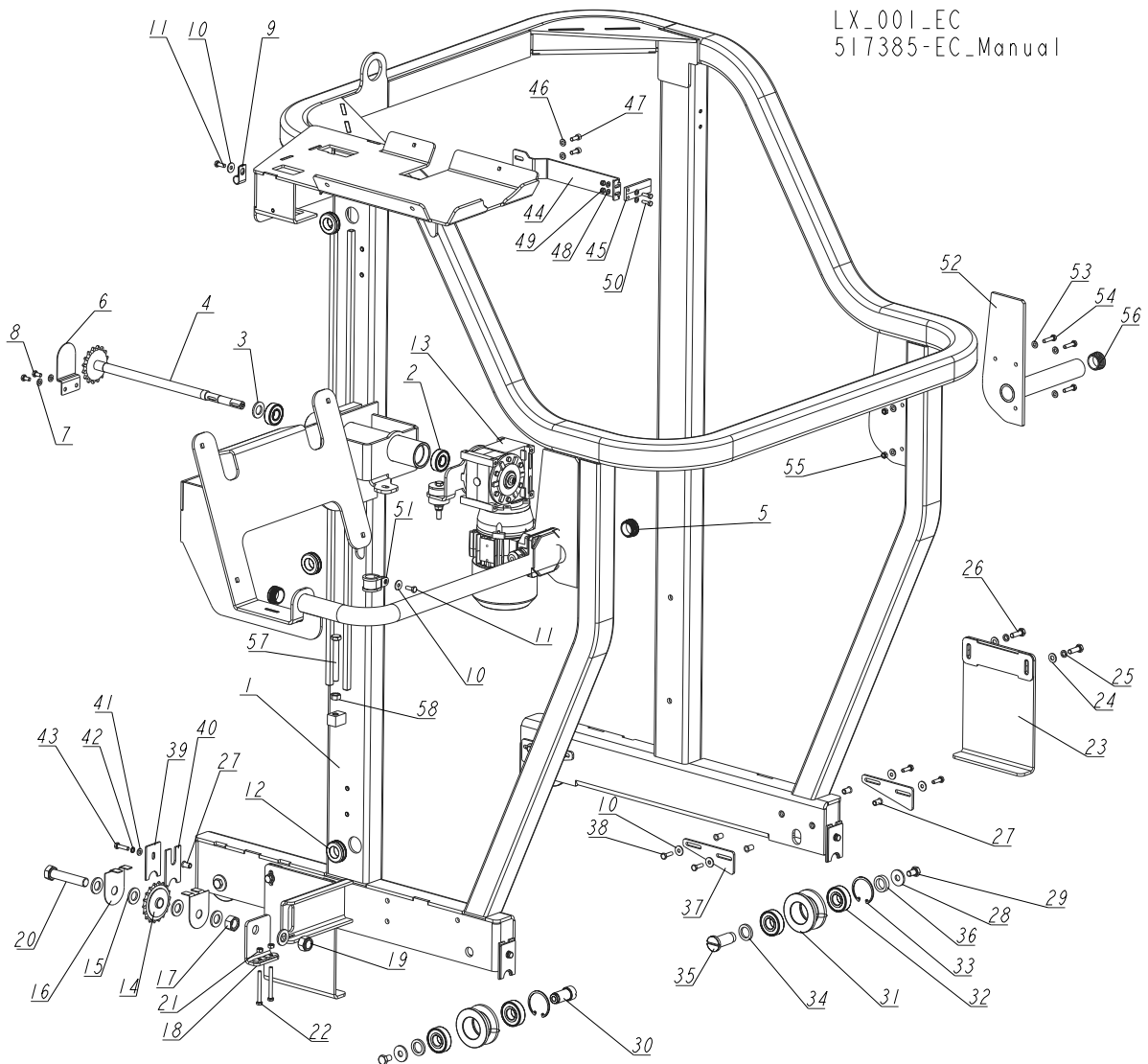

REF	DESCRIPTION (* Indicates Parts Available in Assemblies Only)	PART #	QTY
	MAST LX100 EC COMPLETE	517385-EC	1
	MAST LX100 EC	517386-1EC	1
1	MAST LX100EC WELDMENT	517387-EC	1
2	BEARING, 6203-2RS	086114	2
3	WASHER, 17 FLAT ZINC	F81058-1	1
4	SHAFT WITH SPROCKET	513307	1
5	CAP, SR1530 (30 HOLE) TUBE	517616	2
6	GUARD, LT15 UPPER SAW HEAD SPROCKET	092567-1	1
7	WASHER, 6.5 SPECIAL FLAT ZINC	F81053-1	2
8	BOLT, M6X12-8.8 HEX HEAD FULL THREAD ZINC	F81001-7	2
9	CLAMP, 1/2EMT COATED	P07584	1
10	WASHER, 6.5 SPECIAL FLAT ZINC	F81053-11	10
11	BOLT, M6 X 16 8.8 HEX HEAD FULL THREAD ZINC	F81001-15	2
12	GROMMET, 22 MM ID RUBBER	087400	3

REF	DESCRIPTION (* Indicates Parts Available In Assemblies Only)	PART #	QTY
13	DRIVE ASSEMBLY, UP/DOWN See Section 8.1	517395	1
	SPROCKET ASSEMBLY, BOTTOM	518175	1
14	SPROCKET, #40 IDLER 17T 5/8ID	P04333	1
15	WASHER, 17 FLAT ZINC	F81058-1	5
16	GUARD, LT15 UP/DOWN CHAIN SPROCKET	092566-1	2
17	NUT, M16-5.8 HEX ZINC	F81036-1	1
18	TENSIONER	502525-1	1
19	NUT, M16-8 HEX NYLON ZINC LOCK	F81036-2	1
20	BOLT, M16X80 8.8-B HEX HEAD FULL THREAD ZINC	F81006-11	1
21	NUT, M6-8 HEX ZINC	F81031-1	2
22	BOLT, M6X60-8.8 HEX HEAD FULL THREAD ZINNC	F81001-9	2
	COMPLETE PLATE	517608	2
23	PLATE WELDMENT	517605-1	1
24	WASHER, 8.4 FLAT ZINC	F81054-1	2
25	WASHER 8.2 SPLIT LOCK ZINC	F81054-4	2
26	BOLT, M8X25-8.8-B HEX HEAD FULL THREAD ZINC	F81002-5	2
27	NUT, M6 1.5-4.0 STAINLESS STEEL RIVET	F81031-9	12
28	WASHER,11 SPECIAL FLAT ZINC	088787-1	4
29	BOLT, M10X16-8.8 HEX HEAD FULL THREAD ZINC	F81003-13	4
30	PIN, FIXED TRACK ROLLER	515018	2
	ROLLER ASSEMBLY, TRACK	515015	4
31	ROLLER	514889	1
32	BEARING, 6204 2RS-CX ROLLING	088447	2
33	RING, W47 INSIDE RETAINING	089653	1
34	WASHER, 20.5X30-4, ZINCK	515021-1	4
35	PIN, ADJUSTABLE ROLLER	515101	2
36	WASHER, 20.5X/30-7.4 ZINC	518177-1	2
37	PLATE, ROLLER ADJUSTMENT	516508-1	4
38	BOLT, M6X20-8.8 HEX HEAD FULL THREAD ZINC	F81001-2	8
	COMPLETE SCRAPER	517611	4
39	PLATE, SCRAPER CLAMPING	517610-1	1
40	SCRAPER	517609	1
41	WASHER, 6.4 FLAT ZINC	F81053-1	1
42	WASHER, Z 6.1 SPLIT LOCK ZINC	F81053-3	1
43	BOLT, M6x25 -5.8 HEX HEAD FULL THREAD ZINC	F81001-3	1
	INDICATOR, BLADE HEIGHT SCALE - COMPLETE	517399	1
44	INDICATOR, BLADE HEIGHT SCALE - COMPLETE	517382-1	1
45	INDICATOR, BLADE HEIGHT SCALE	094821	1
46	WASHER, 6.4 FLAT ZINC	F81053-1	2
47	SCREW, M6X16 HEX SOCKET HEAD CAP	F81001-21	2
48	WASHER, 5.3 FLAT ZINC	F81052-1	4
49	NUT, M5-8-FE/ZN5 DIN985	F81030-2	2
50	BOLT, M5X16-8.8 HEX HEAD FULL THREAD ZINC	F81000-20	2
51	CLAMP, RSGU 1.30/20	F81087-1	1
	HANDLE, EC, COMPLETE	519919	1
52	HANDLE EC WELDMENT	519918-1	1
53	WASHER, 6.5 SPECIAL FLAT ZINC	F81053-1	6

6 **SAWMILL MAST**
EC Mast

REF	DESCRIPTION (* Indicates Parts Available in Assemblies Only)	PART #	QTY	
54	BOLT, M6x25 -5.8 HEX HEAD FULL THREAD ZINC	F81001-3	3	
55	NUT, M6-8-B HEX NYLON ZINC LOCK	F81031-2	3	
56	CAP, SR1530 (30 HOLE) TUBE	517616	1	
57	BOLT, M10-80-8.8 HEX HEAD FULL THREAD ZINC	F81003-76	1	
58	NUT, M10-8-B HEX ZINC	F81033-3	1	

SECTION 7 POWER FEED SYSTEM

7.1 Power Feed Assembly

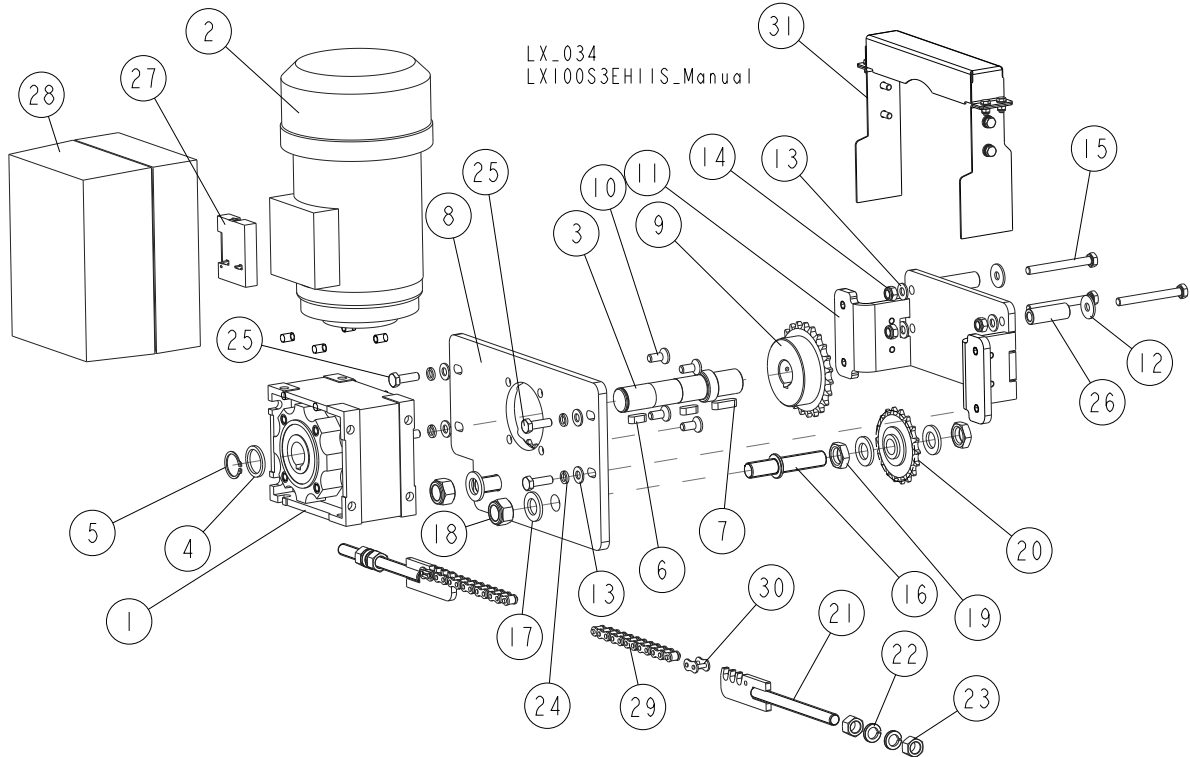

REF.	DESCRIPTION (* Indicates Parts Available in Assemblies Only)	PART #	QTY
	S3/AC-P POWER FEED EQUIPMENT	517910-S3 M2	1
	S4/AC-P POWER FEED EQUIPMENT	517910-S4	1
	S5/AC-P POWER FEED EQUIPMENT	517910-S5	1
	M3/AC-P POWER FEED EQUIPMENT	517910-M3	1
	M4/AC-P POWER FEED EQUIPMENT	517910-M4	1
	M5/AC-P POWER FEED EQUIPMENT	517910-M5	1
	POWER FEED ASSEMBLY (AC)	517885	1
	MOTOREDUCER, GCM 050 U25 P80B14 V5 80K2	517905	1
1	REDUCER, 501008, 500617	083689	1
2	MOTOR, 0.75 KW 2770 r.p.m. DMA-80K2 B14	517908	1
3	SHAFT, OUTPUT	517884	1
4	WASHER 25.1/32-3 ZINC	500863-1	1
5	RING, 25Z OUTSIDE RETAINING	F81090-22	1
6	KEY, A8X7X20 PARALLEL	099059	2
7	KEY, A 8X7X28 PARALLEL	096035	1
8	PLATE, GEARBOX MOUNTING	517899-1	1
9	SPROCKET, 08B-1; Z=23; DP=93.27(T 72548)	517883-1	1
10	SCREW, M8X20-8.8-FE/ZN5 DIN7991	F81002-70	4
11	BRACKET, MOUNTING	517886-1	1
12	WASHER, ISO 7093-1-8-200 HV-A2E	F81054-11	3
13	WASHER, 8.4 FLAT ZINC	F81054-1	7

7 POWER FEED SYSTEM

Power Feed Assembly

REF.	DESCRIPTION (* Indicates Parts Available In Assemblies Only)	PART #	QTY
14	NUT, M8-8-B HEX NYLON ZINC LOCK	F81032-2	3
15	BOLT, M8 X 75 8.8 HEX HEAD ZINC	F81002-91	3
	SPROCKET ASSEMBLY	517890	2
16	SHAFT, SPROCKET	517891-1	1
17	WASHER, 17 FLAT ZINC	F81058-1	3
18	NUT, M16-8 HEX NYLON ZINC LOCK	F81036-2	1
19	NUT, M16 8 HEX THIN ZINC	F81036-4	2
20	SPROCKET, IDLER Z=18 KSR16.L0.08.10.18.0	088700	1
21	BRACKET, POWER FEED CHAIN	517895-1	2
22	WASHER, Z12.2 SPLIT LOCK ZINC	F81056-2	4
23	NUT, M12-8-B HEX ZINC	F81034-1	4
24	WASHER 8.2 SPLIT LOCK ZINC	F81054-4	4
25	BOLT, M8X25-8.8-B HEX HEAD FULL THREAD ZINC	F81002-5	4
26	BUSHING 9/16-44.5 ZINC	517914-1	3
27	MODULE, STANDARD I/O TYPE E84DGFCSNNP	509120	1
28	CONVERTER, FREQUENCY TYPE E84DGDVB55142PS	509119	1
29	CHAIN, 08B; =6.72 M (529 LINKS)	517898-S3 M2	1
	CHAIN, 08B; =8.57 M (675 LINKS)	517898-S4	1
	CHAIN, 08B; =10.43 M (821 LINKS)	517898-S5	1
	CHAIN, 08B; =9.49 M (747 LINKS)	517898-M3	1
	CHAIN, 08B; =12.26 M (965 LINKS)	517898-M4	1
	CHAIN, 08B; =15.05 M (1185 LINKS)	517898-M5	1
30	LINK, 08B-1PZ CHAIN	091625	2
31	COVER ASSEMBLY, POWER FEED See Section 7.2	517915	1

7.2 Power Feed Cover Assembly

LX_035
 LX100S3EH11S_Manual

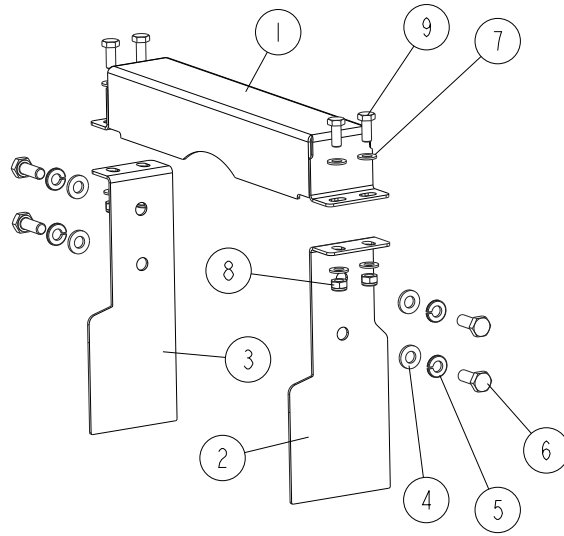

REF.	DESCRIPTION (◆ indicates parts available in assemblies only)	PART #	QTY
	COVER ASSEMBLY, POWER FEED	517915	1
1	COVER, TOP	517912-1	1
2	PLATE, RIGHT SIDE	517906-1	1
3	PLATE, LEFT SIDE	517909-1	1
4	WASHER, 6.4 FLAT ZINC	F81053-1	4
5	WASHER, 6,1 DIN 127 (A2-304) SPLIT LOCK	F81053-4	4
6	BOLT, M6 X 16 8.8 HEX HEAD FULL THREAD ZINC	F81001-15	4
7	WASHER, 5.3 FLAT ZINC	F81052-1	8
8	NUT, M5-8-FE/ZN5 DIN985	F81030-2	4
9	BOLT, M5 X 12-5.8 HEX HEAD FULL THREAD ZINC	F81000-5	4

SECTION 8 UP/DOWN SYSTEM

8.1 Up/Down Drive Assembly

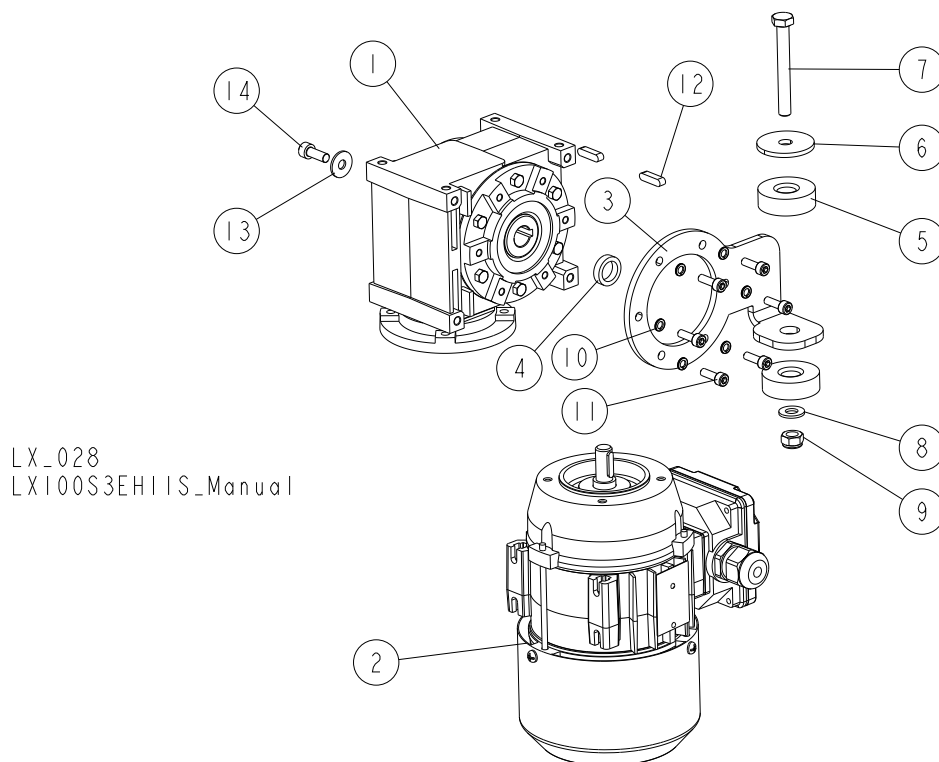

REF.	DESCRIPTION (◆ indicates parts available in assemblies only)	PART #	QTY
	DRIVE ASSEMBLY, UP/DOWN	517395	1
	MOTOREDUCER, MRA-03/16 [0.25-2800/90/11-B] KM2/W/V6	517394	1
1	GEAR-BOX, MRA-03/16 [0.25-2800/90/11-B] KM2/W/V6	517393	1
2	MOTOR, 63B14 (0.25-2800-90/11)	517104	1
3	ARM, TORQUE	517390-1	1
4	BUSHING, 14/20-5	513160	1
5	WASHER, RUBBER	090443	2
6	WASHER, 5X9X38	513086	1
7	BOLT, M8X65 8.8 HEX HEAD FULL THREAD ZINC	F81002-9	1
8	WASHER, 8.4 FLAT ZINC	F81054-1	1
9	NUT, M8 8 HEX NYLON ZINC LOCK	F81032-2	1
10	WASHER, 5.1 SPLIT LOCK	F81052-2	6
11	SCREW, M5X16-8.8 HEX SOCKET HEAD CAP ZINC	F81000-25	6
12	KEY, A5X5X20 PARALLEL	513320	2
13	WASHER, 6.5 SPECIAL FLAT ZINC	F81053-11	1
14	SCREW, M6X16 8.8 HEX SOCKET HEAD CAP ZINC	F81001-21	1

8.2 Blade Height Scale Assembly

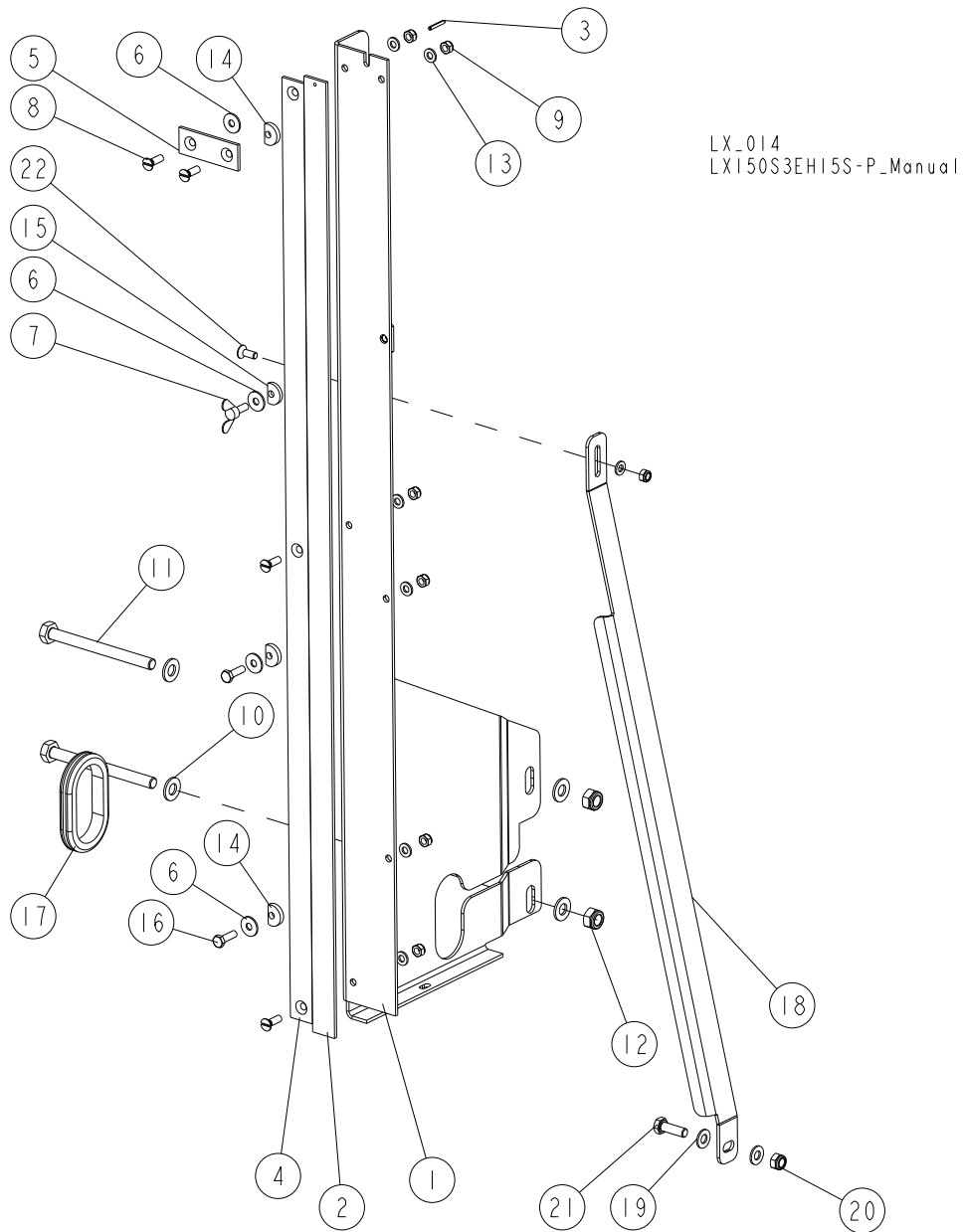

REF.	DESCRIPTION (◆ indicates parts available in assemblies only)	PART #	QTY
	BLADE HEIGHT SCALE - COMPLETE (METRIC)	517400	1
1	BRACKET WELDMENT, BLADE HEIGHT SCALE	517401-1	1
2	BAR, INCH SCALE	093133	1
3	PIN, 3X20 GEOMET ROLL	F81044-5	1
4	BAR, SCALE	092750	1
5	BAR, SCALE CLAMPING	093134	1
6	WASHER, 6.5 SPECIAL FLAT ZINC	F81053-11	4
7	SCREW, M6X16 DIN-316/BN-276 ZINC-PL. WING	F81001-16	1
8	SCREW, M6X20-5.8-B SLOTTED COUNTERSUNK HEAD ZINC	F81001-31	4
9	NUT, M6-8-B HEX NYLON ZINC LOCK	F81031-2	7
10	WASHER, 10.5 FLAT ZINC	F81055-1	4

REF.	DESCRIPTION (◆ indicates parts available in assemblies only)	PART #	QTY	
11	BOLT, M10X115-8.8 HEX HEAD	F81003-19	2	
12	NUT, M10-8-B HEX NYLON ZINC LOCK	F81033-1	2	
13	WASHER, 6.4 FLAT ZINC	F81053-1	7	
14	WASHER, 6.2X20X4.5 SPECIAL	503098	3	
15	WASHER, 6.2X20X3.5 SPECIAL	503096	1	
16	BOLT, M6X20 8.8 HEX HEAD FULL THREAD ZINC	F81001-2	2	
17	GROMMET, RUBBER	087065	1	
18	BRACKET, BLADE HEIGHT SCALE SUPPORT	517403-1	1	
19	WASHER, 8.4 FLAT ZINC	F81054-1	2	
20	NUT, M8 8 HEX NYLON ZINC LOCK	F81032-2	1	
21	BOLT, M8X25-8.8-B HEX HEAD FULL THREAD ZINC	F81002-5	1	
22	SCREW, M6X16-10.9 DIN7991 FLAT SOCKET HEAD CAP ZINC	F81001-55	1	

8.3 Up/Down Sprockets

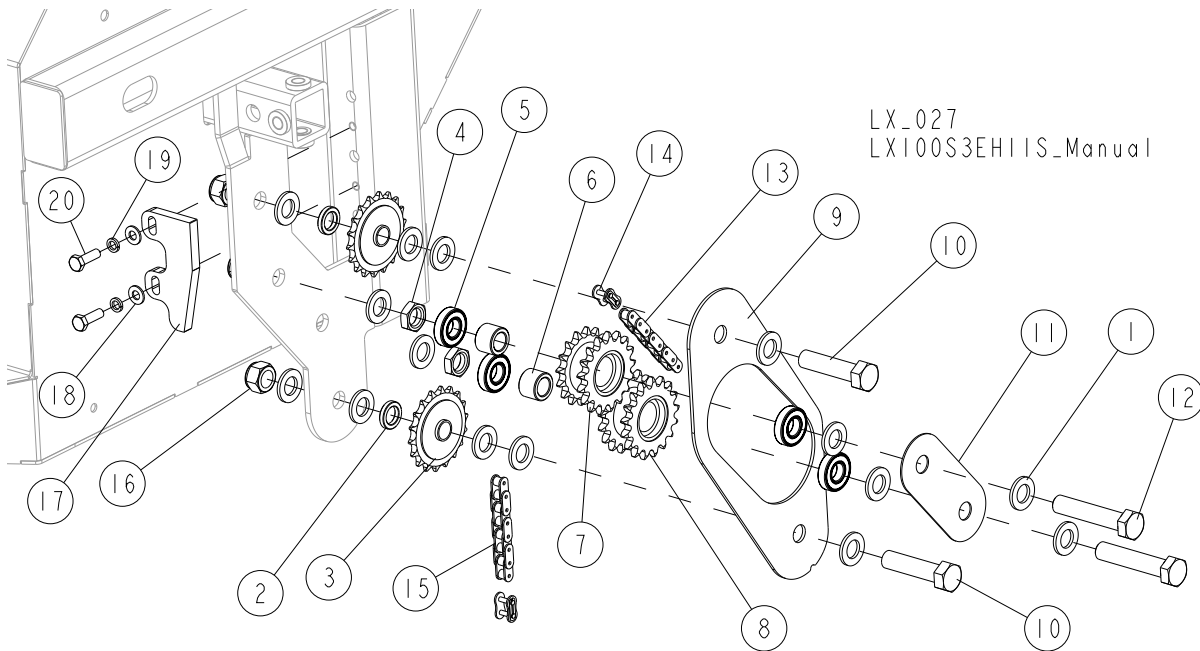

REF.	DESCRIPTION (◆ indicates parts available in assemblies only)	PART #	QTY
1	WASHER, 17 SPLIT LOCK ZINC	F81058-1	18
2	BUSHING	095937-1	2
3	SPROCKET, #40 IDLER 17T 5/8 ID	P04333	2
4	NUT, M16 THIN ZINC	F81036-4	2
5	BEARING, R10-2NSL	P04156	4
6	BUSHING	095938-1	2
7	SPROCKET WELDMENT, 16/17 DUAL	086813-1	1
8	SPROCKET WELDMENT, 17/17 DUAL	086812-1	1
9	GUARD, UP/DOWN CHAIN INTERNAL	014907-1	1
10	BOLT, M16X65 8.8 HEX HEAD FULL THREAD ZINC	F81006-1	2
11	PLATE, UP/DOWN CHAIN GUARD	087104-1	1
12	BOLT, M16X80-8.8 HEX HEAD FULL THREAD ZINC	F81006-11	2
13	CHAIN, #40X15 1/2	P12496	1
14	LINK, #40 MASTER	P04200	2
15	CHAIN, #40X112 1/2"	014831	1
16	NUT, M16-8 HEX NYLON ZINC LOCK	F81036-2	4
17	PLATE, LIMIT SWITCH ACTIVATOR - COMPLETE	516510	1
17	PLATE, LIMIT SWITCH ACTIVATOR	516509-1	1
18	WASHER, 8.4 FLAT ZINC	F81054-1	2
19	WASHER, 8.2 SPLIT LOCK ZINC	F81054-4	2
20	BOLT, M8x25-8.8-B HEX HEAD FULL THREAD ZINC	F81002-5	2

SECTION 9 MOTOR ASSEMBLY

9.1 E11/E15 Motor Kit

LX_032_A
LX100S3EH15_Manual

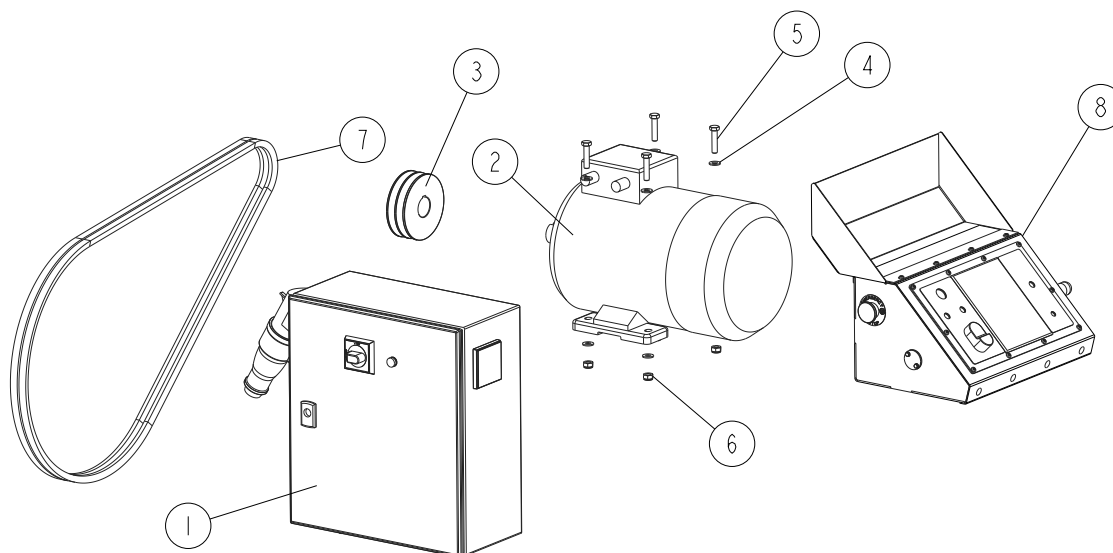

REF.	DESCRIPTION (◆ Indicates Parts Available In Assemblies Only)	PART #	QTY
	MOTOR KIT, E11 400V	516793-3	1/0
	MOTOR KIT, E15 400V	516789-3	0/1
1	BOX ASSEMBLY, E11 CE ELECTRIC See Section 9.3	516794	1/0
	BOX ASSEMBLY, E15 CE ELECTRIC See Section 9.3	516790	0/1
2	MOTOR, 7.5KW 380V 3-PHASE ELECTRIC (PL)	085482	1/0
	MOTOR, 11KW 380V 3-PHASE ELECTRIC (PL)	P85186	0/1
3	PULLEY, E11 2-GROOVE	086807-1	1/0
	PULLEY, E15 2-GROOVE	091560	0/1
4	WASHER, 10.5 FLAT ZINC	F81055-1	8
5	BOLT, M10X45-8.8 HEX HEAD FULL THREAD ZINC	F81003-3	4
6	NUT, M10-8-B HEX NYLON ZINC LOCK	F81033-1	4
7	BELT, BX81 LT15	014819	1/0
	BELT, 2BX81 LT20	014819-2	0/1
8	BOX, AC CONTROL - COMPLETE See Section 9.6	518150-3	1

9.2 E11S/E15S Motor Kit

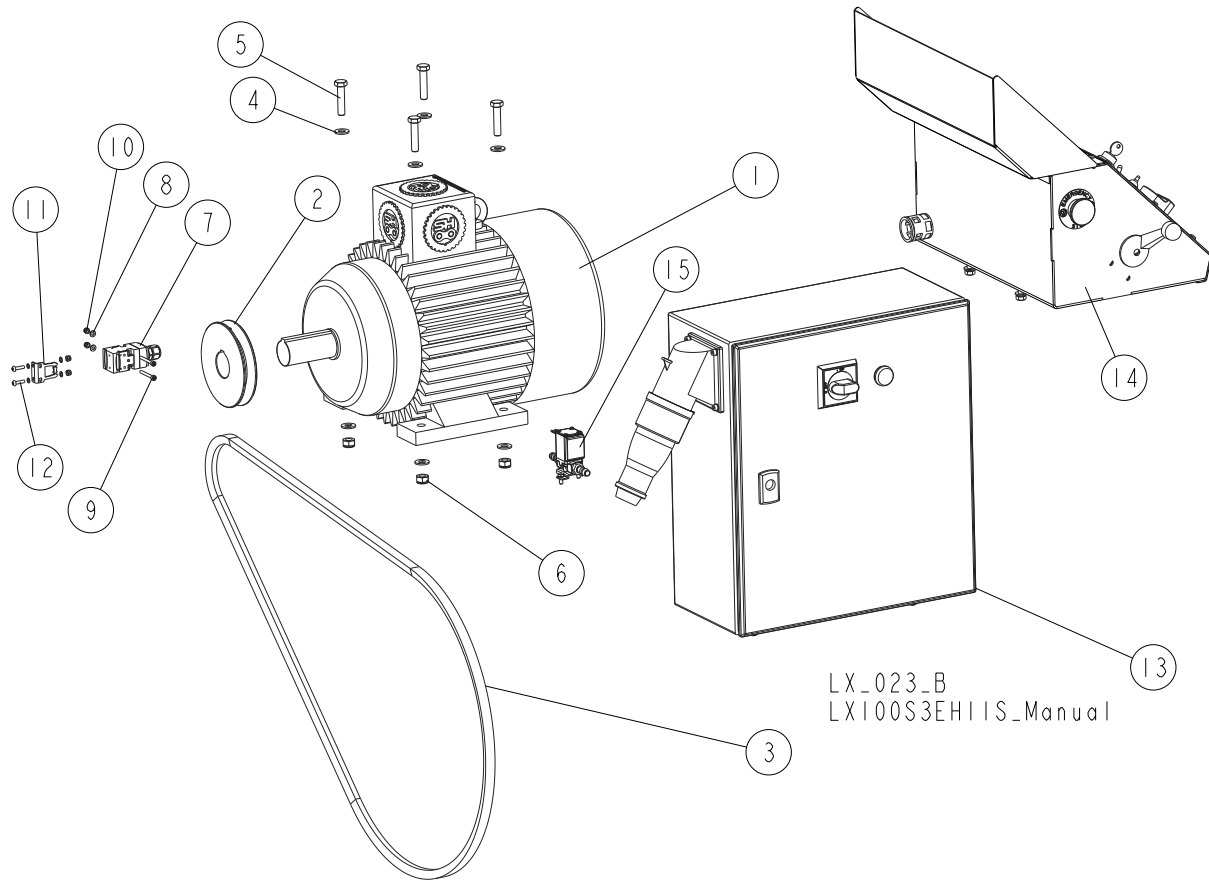

REF.	DESCRIPTION (◆ Indicates Parts Available in Assemblies Only)	PART #	QTY
	MOTOR KIT, E11 400V CE	516793	1/0
	MOTOR KIT, E15 400V CE	516789	0/1
1	MOTOR, 7.5 KW SG132S-2B-HM 400 V	090993	1/0
	MOTOR, 11 KW PSg132 S2 - HM 400 V	089049	0/1
2	PULLEY, LT15 E11 BELT ARM	086807-1	1/0
	PULLEY, E15 BELT ARM	091560	0/1
3	BELT, BX81 LT15	014819	1/0
	BELT, 2BX81	014819-2	0/1
4	WASHER, 10.5 FLAT ZINC	F81055-1	8
5	BOLT, M10X45-8.8 HEX HEAD FULL THREAD ZINC	F81003-3	4
6	NUT, M10-8-B HEX NYLON ZINC LOCK	F81033-1	4
7	SWITCH, AZ17-11ZRK SAFETY	094232	1
8	WASHER 4.3 FLAT ZINC	F81051-2	2
9	SCREW, M4X35-8.8 HEX SOCKET HEAD CAP ZINC	F81011-34	2
10	NUT, M4-B HEX NYLON ZINC LOCK	F81029-1	4
11	KEY, A217/170-B5 SAFETY SWITCH	094422	1
12	SCREW, M4X16 5.8-B CROSS RECESSED PAN HEAD	F81011-42	2
13	BOX, E11 CE ELECTRIC See Section 9.3	516794	1/0
	BOX, E15 CE ELECTRIC See Section 9.3	516790	0/1
14	BOX, AC CONTROL - COMPLETE See Section 9.6	518150	1
15	LUBE KIT, BLADE See Section 9.7	518651	1

9.3 E15-EC Motor Kit

516789-EC_001
516789-EC_Manual

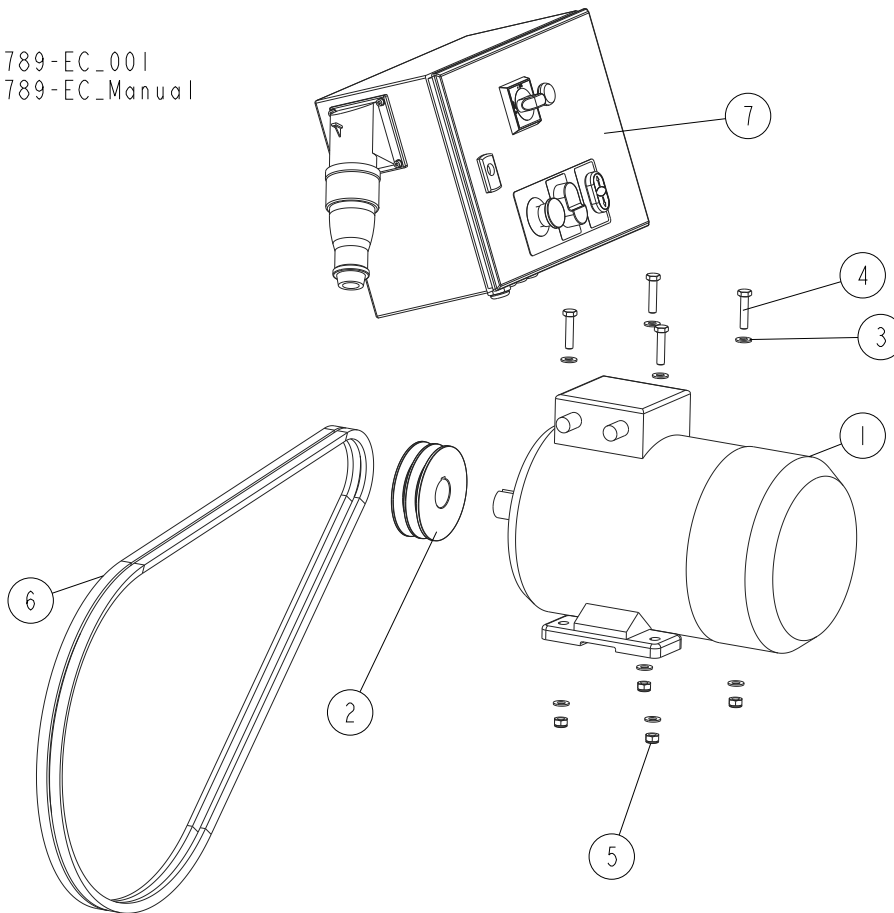

REF.	DESCRIPTION (◆ Indicates Parts Available In Assemblies Only)	PART #	QTY
	MOTOR KIT, E15 400V FOR LX100 EC	516789-EC	1
1	MOTOR, 11KW 1LE1002-1CA63-4AA4-Z	P85186	1
2	PULLEY, E15 MOTOR 2-GROOVE	091560	1
3	WASHER, 10.5 FLAT ZINC	F81055-1	8
4	BOLT, M10X45 HEX HEAD FULL THREAD ZINC	F81003-3	4
5	NUT, M10-8-B HEX NYLON ZINC LOCK	F81033-1	4
6	V-BELT, 2BX81	014819-2	1
7	BOX, LX100 EC- E15 ELECTRIC See Section 9.5	517376	1

9.4 Electric Box

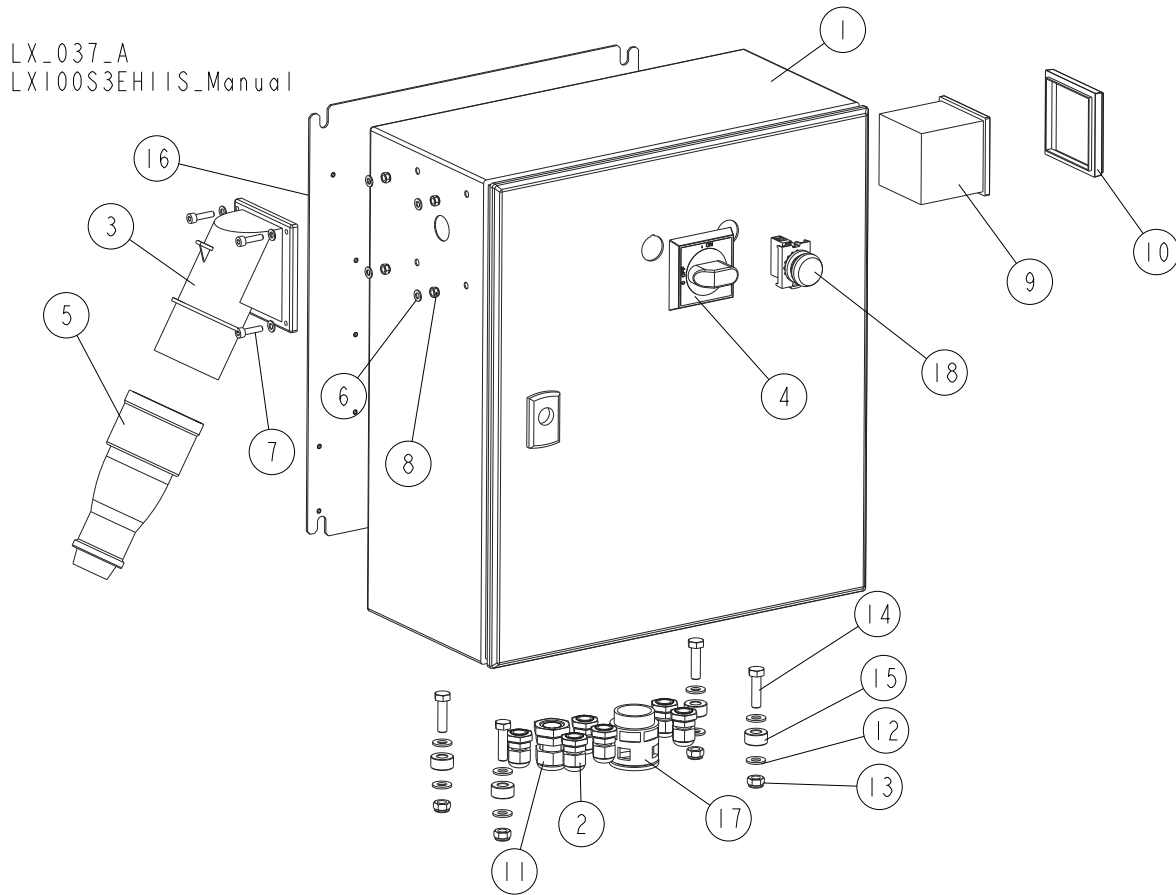

REF.	DESCRIPTION (◆ Indicates Parts Available in Assemblies Only)	PART #	QTY
1	BOX ASSEMBLY, E11 CE ELECTRIC	516794	1
	BOX ASSEMBLY, E15 CE ELECTRIC	516790	1
1	BOX, CE ELECTRIC	517879	1
2	GLAND, DP9/H	F81096-2	6
3	PLUG, MAIN W/SWITCH-ADJUSTABLE PHASE GT	E85235	1
4	HANDLE, OHB S2A1 ABB SWITCH	502312-1	1
5	PLUG-IN-SOCKET, PLASTIC SEALED GT	E85236	1
6	WASHER, 5.3 FLAT ZINC	F81052-1	8
7	SCREW, M5X20 8.8 HEX SOCKET HEAD CAP ZINC	F81000-72	4
8	NUT, M5-8-FE/ZN5 DIN985	F81030-2	4
9	AMMETER EQB72 25/50A FOR E15 ELECTRIC MOTOR	505371	1
10	COVER, IP65 METER EQ72	505389	1
11	GLAND, DP16/H CABLE	F81096-7	1
12	WASHER, 8.4 FLAT ZINC	F81054-1	8
13	NUT, M8-8-B HEX NYLON ZINC LOCK	F81032-2	4
14	BOLT, M8X30-5.8 HEX HEAD FULL THREAD ZINC	F81002-2	4
15	BUSHING, 9/20-10 ZINC-PLATED	510668-1	4
16	PLATE, ELECTRIC BOX MOUNT	518178-1	1
17	CONNECTOR, MAXI-FLEX GP29	086576	1
18	LIGHT, M22 LED 24V WHITE CONTROL	090448	1

9.5 Electric Box, E15-EC

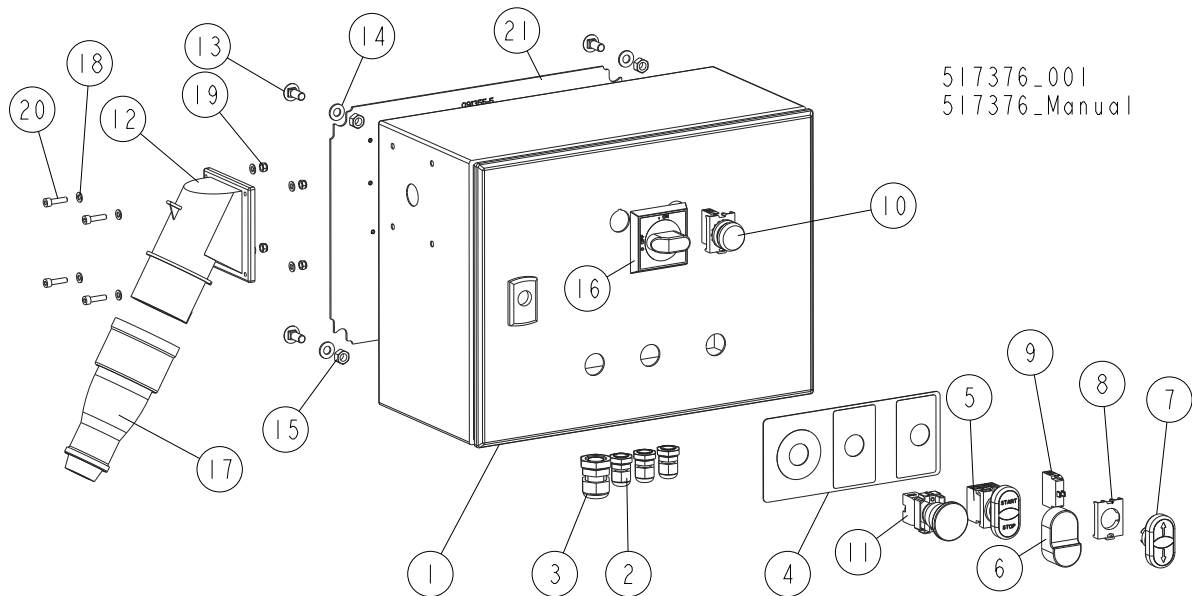

REF.	DESCRIPTION (◆ Indicates Parts Available in Assemblies Only)	PART #	QTY
	BOX, LX100 EC- E15 ELECTRIC	517376	1
1	BOX, LX100 EC ELECTRIC	519911	1
2	GLAND, DP9/H CABLE	F81096-2	3
3	GLAND, DP16/H CABLE	F81096-7	1
4	DECAL, LX100 EC ELECTRIC BOX	517117	1
5	SWITCH, 24V ILLUMINATED START/STOP (MOELLER)	090452	1
6	DIAPHRAGM, M22-T-DD MOELLER	090462	1
7	ACTUATOR, M22-DD-S-X7/X7 PUSHBUTTON	090917	1
8	ADAPTER, M22-A FIXING	100905	1
9	ELEMENT, M22 K10 MOELLER CONTACT	091362	2
10	LIGHT, M22 LED 24V BLUE CONTROL	090448	1
11	BUTTON, XB4 BS542 EMERGENCY STOP	086556	1
12	PLUG, 32A 5P 400V IP67	E85235	1
13	BOLT, M8X20-8.8 CARRIAGE ZINC	F81002-11	4
14	WASHER, 8.4 FLAT ZINC	F81054-1	4
15	NUT, M8-8-B HEX ZINC	F81032-1	4
16	HANDLE, OHB S2A1 ABB SWITCH	502312-1	1
17	SOCKET, 32A 5P 400V IP67	E85236	1
18	WASHER, 5.3 FLAT ZINC	F81052-1	8
19	NUT, M5-8-FE/ZN5 DIN985	F81030-2	4
20	SCREW, M5X20 8.8 HEX SOCKET HEAD CAP ZINC	F81000-72	4
21	PLATE, LX100-EC ELECTRIC BOX MOUNT	091355-5	1

9.6 AC Control Box

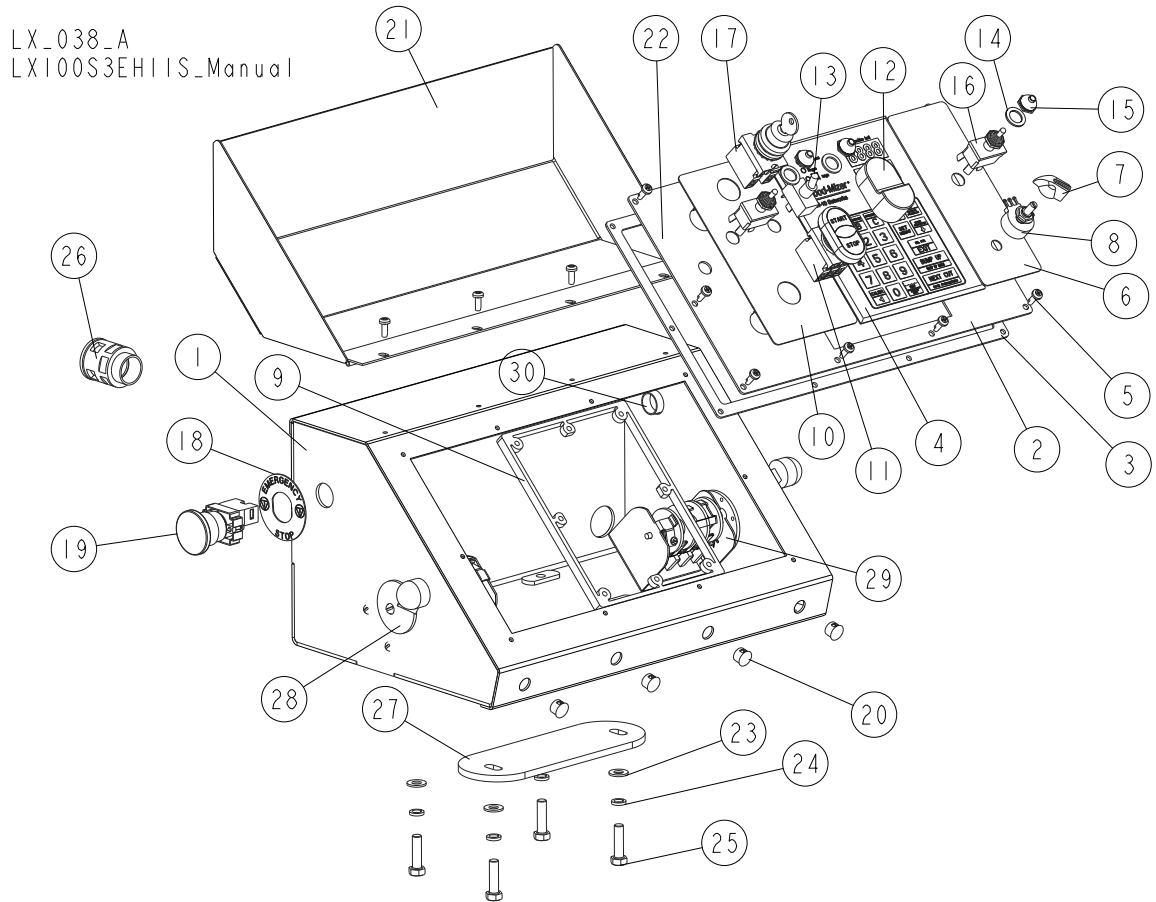

REF.	DESCRIPTION (◆ Indicates Parts Available in Assemblies Only)	PART #	QTY
	BOX, AC CONTROL - COMPLETE	518150	1
1	BOX WELDMENT, AC	518155-1	1
	PANEL, AC CONTROL BOX FRONT - COMPLETE	518157	1
2	PANEL, AC CONTROL BOX FRONT	518156-1	1
3	GASKET, LT20 CONTROL BOX	097132	1
4	SW-10 SETWORKS CONTROLLER	500628	1
5	BOLT, #10-24 X 1/2 PH PAN HEAD, TYPE 23	F05015-17	10
6	DECAL, AC/DC CONTROL BOX - RIGHT	516988	1
7	KNOB, SPEED CONTROL	P06257	1
8	POTENTIOMETER, 1K LTAGA	E20519	1
9	FRAME, SW-08 SETWORKS REAR	100909	1
10	DECAL, AC/DC LT15 CONTROL BOX - LEFT	518161	1
11	SWITCH, 24V START/STOP	090452	1
12	DIAPHRAGM, M22-T-DD MOELLER	090462	1
13	SWITCH, SPST ON/OFF 15A 25 TABS TOGGLE	P03027	1
14	WASHER, 1/2X3/4X1/16 NYLON	P05251-1	3
15	BOOT, TOGGLE SWITCH	P02575	3
16	SWITCH, DPDT TOGGLE 21A REV MOM SPADE	024200	2
17	SWITCH, M22 3-POSITION KEY	091361	1

9 MOTOR ASSEMBLY

AC Control Box

REF.	DESCRIPTION (◆ Indicates Parts Available In Assemblies Only)	PART #	QTY	
18	WASHER, EMERGENCY STOP SWITCH	086561	1	
19	SWITCH, XB4 BS542 EMERGENCY STOP	086556	1	
20	CAP, DP 812 HEJMAN 12.7 DIA. HOLE	086773	4	
21	COVER, CONTROL BOX - COMPLETE	097135-1	1	
22	BOLT, #10-24 X 1/2 PH PAN HEAD, TYPE 23	F05015-17	4	
23	WASHER, 8.4 FLAT ZINC	F81054-1	4	
24	WASHER, 8.2 SPLIT LOCK ZINC	F81054-4	4	
25	BOLT, M8x30-5.8 HEX HEAD FULL THREAD ZINC	F81002-2	4	
26	CONNECTOR MAXI-FLEX GP29	086576	1	
27	WASHER, BOX CONTROL	517660-1	1	
28	SWITCH, 1992GS POWER FEED (SERVICE PACKAGE)	E20438	1	
29	SWITCH, 1992 UP/DOWN (SERVICE PACKAGE)	E20440	1	
30	PLUG, 1086 DIA. 22.2 HOLE	093544	1	

9.7 Blade Lube Kit

LX_044
LX100S3EH11S_Manual

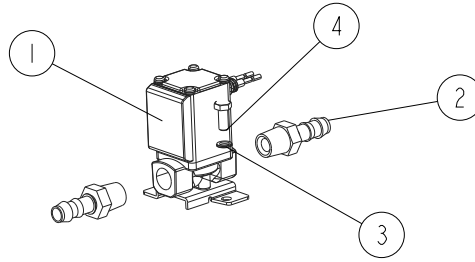

REF.	DESCRIPTION (◆ Indicates Parts Available In Assemblies Only)	PART #	QTY
	LUBE KIT, LX100 AC BLADE	518651	1
1	VALVE, VX212FZ1UAXB SOLENOID	514046	1
2	FITTING, 3/8BARB 1/4NPT MALE NYLON	P04682	2
3	WASHER, 5.1 SPLIT LOCK ZINC	F81052-2	2
4	BOLT, M5 X 12-5.8 HEX HEAD FULL THREAD ZINC	F81000-5	2