

# **G13 Engine**

## **Safety, Operation, Maintenance & Parts Manual**

---

**LT15**

**rev. B4.00**

---



**Safety is our #1 concern!** Read and understand all safety information and instructions before operating, setting up or maintaining this machine.

*Form #800*

|                  |   |            |
|------------------|---|------------|
| <b>SECTION 1</b> | <b>SAFETY &amp; GENERAL INFORMATION</b> | <b>1-1</b> |
| 1.1              | Refueling .....                         | 1-2        |
| 1.2              | Engine Operation.....                   | 1-2        |
| <b>SECTION 2</b> | <b>OPERATION</b>                        | <b>2-1</b> |
| 2.1              | Starting The Engine.....                | 2-1        |
| <b>SECTION 3</b> | <b>MAINTENANCE</b>                      | <b>3-1</b> |
| 3.1              | Air Filter & Pre-Cleaner.....           | 3-1        |
| 3.2              | Engine Oil & Filter.....                | 3-2        |
| 3.3              | Air Cooling System.....                 | 3-2        |
| 3.4              | Fuel Filter .....                       | 3-2        |
| 3.5              | Miscellaneous Maintenance .....         | 3-2        |
| 3.6              | Drive Belt Adjustment.....              | 3-3        |
| 3.7              | RPM Adjustments .....                   | 3-5        |
| <b>SECTION 4</b> | <b>REPLACEMENT PARTS</b>                | <b>4-1</b> |
| 4.1              | How To Use The Parts List .....         | 4-1        |
| 4.2              | Sample Assembly .....                   | 4-1        |
| 4.3              | Engine Assembly.....                    | 4-2        |
| 4.4              | Brake/Belt Tensioner Assembly.....      | 4-4        |

## SECTION 1 SAFETY & GENERAL INFORMATION



**IMPORTANT!** This manual is provided as a supplement to the equipment manufacturer's manuals. This manual takes into account the specific use of engines on the Wood-Mizer sawmill. Only safety, maintenance, and operating procedures that are not provided by the manufacturer are supplied in this manual. Refer to the manufacturer's manual before attempting to operate this equipment.



This symbol calls your attention to instructions concerning your personal safety. Be sure to observe and follow these instructions. This symbol accompanies a signal word. The word **DANGER** indicates an imminently hazardous situation which, if not avoided, will result in death or serious injury. **WARNING** suggests a potentially hazardous situation which, if not avoided, could result in death or serious injury. **CAUTION** refers to potentially hazardous situations which, if not avoided, may result in minor or moderate injury to persons or equipment. Read all safety instructions before operating this equipment and observe all safety warnings!

# 1 Safety & General Information

## Refueling

---

### 1.1 Refueling



**WARNING!** Store gasoline away from sawdust and other flammable materials. Failure to do so may result in serious injury.

### 1.2 Engine Operation



**DANGER!** Always be sure the blade is disengaged and all persons are out of the path of the blade before starting the engine or motor. Failure to do so will result in serious injury.



**WARNING!** Do not for any reason adjust the engine drive belts or belt support bracket with the engine running. Doing so may result in serious injury.

**WARNING!** Remove the blade before performing any engine service. Failure to do so may result in serious injury.

**WARNING!** Always wear proper and necessary safety equipment when performing service functions. Proper safety equipment includes eye protection, breathing protection, hand protection and foot protection.



**IMPORTANT!** Always dispose of coolant, oil, fuel, oil filters and fuel filters in a responsible manner and in conformance with local, state and federal regulations.

## SECTION 2 OPERATION

### 2.1 Starting The Engine

#### Engine Start



**WARNING!** Do not start the engine when the tensioner lever is in the ENGAGED (up) position. Always be sure the blade is disengaged and all persons are away from the sawmill before starting the engine.

1. Set and lock with the pin the tensioner lever in the ENGINE START position (middle position).

See Figure 2-1.

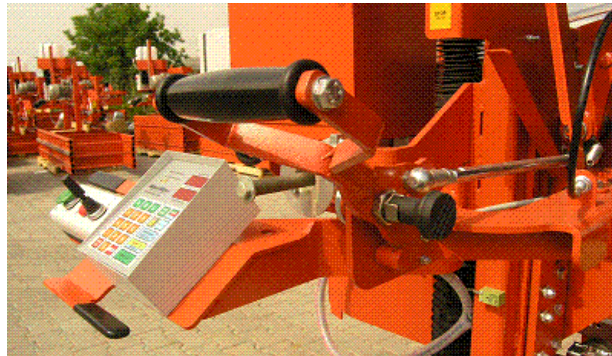

**FIG. 2-1**

2. Close the engine choke by moving the choke lever to the START position.

## **2** Operation

### *Starting The Engine*

See Figure 2-2.

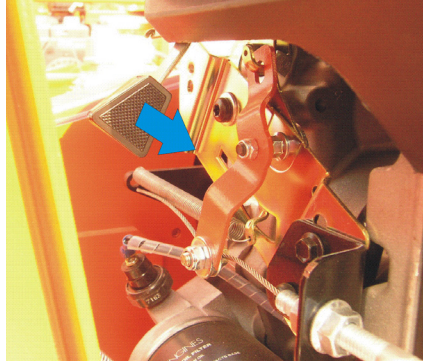

**FIG. 2-2**

3. Turn the key to the START position.

See Figure 2-3.

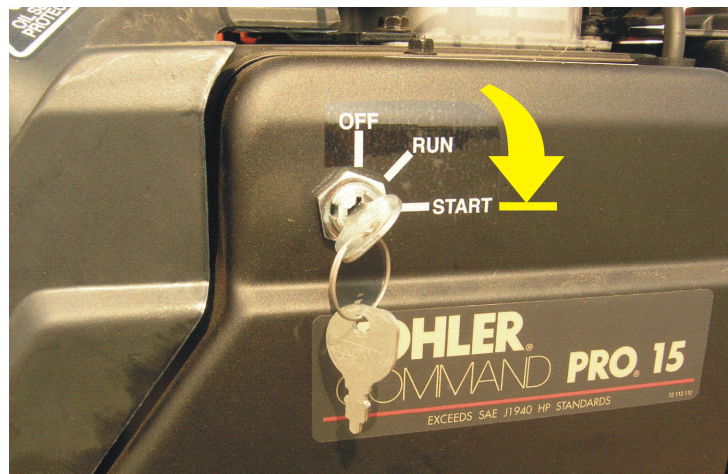

**FIG. 2-3**

4. When the engine is started, release the tensioner lever to the IDLING position and slowly open the choke by moving the choke lever to the OFF position.

See Figure 2-4.

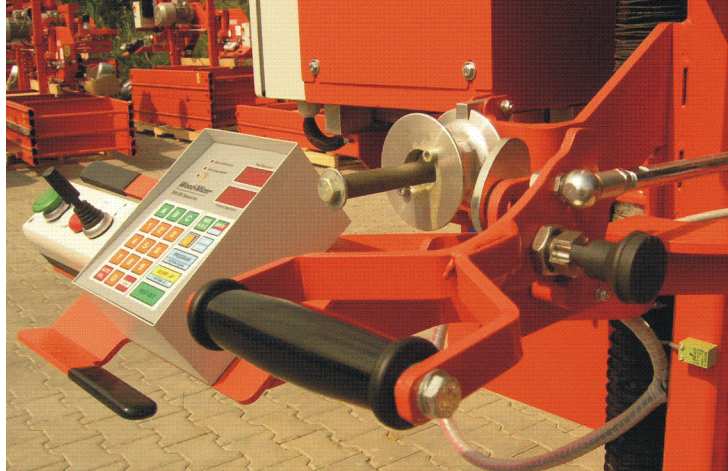

**FIG. 2-4**

## 2

### Operation

#### *Starting The Engine*

5. To engage the blade, press and hold the green button on the control box and push the tensioner lever to the ENGAGED (up) position.

See Figure 2-5.

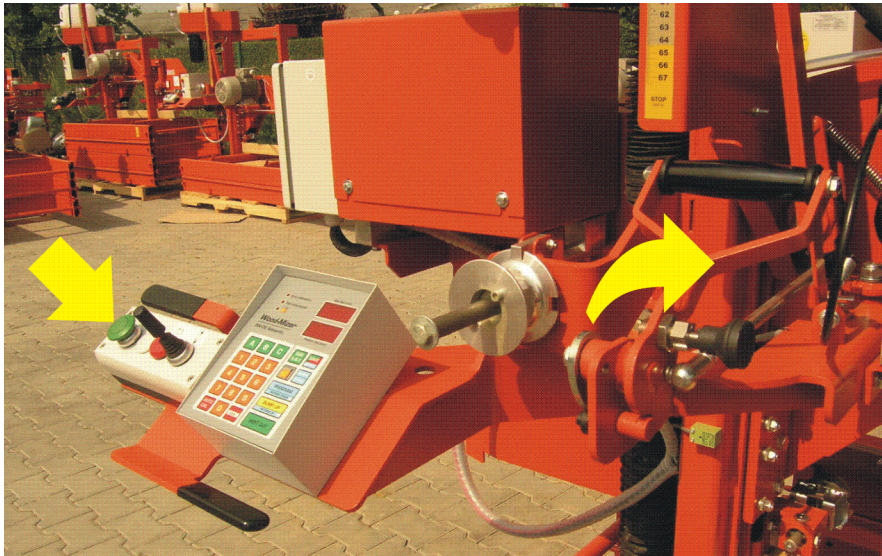

**FIG. 2-5**

#### **Engine Shutoff**

1. Disengage the tensioner lever to stop the blade (down position).
2. Let the engine run for 15 seconds without load and then turn the key to the OFF position.



## SECTION 3 MAINTENANCE



**IMPORTANT!** This manual only provides information about additional procedures or procedures to be performed at different time intervals than found in the engine manufacturer's manuals. Refer to the [manufacturer's manual](#) for complete maintenance instructions.



**WARNING!** Remove the blade before performing any engine service. Failure to do so may result in serious injury.



**This symbol** identifies the interval (hours of operation) which each maintenance procedure should be performed. "AR" signifies maintenance procedures which should be performed as required.

### 3.1 Air Filter & Pre-Cleaner



**WARNING!** Always wear proper and necessary safety equipment when performing service functions. Proper safety equipment includes eye protection, breathing protection, hand protection and foot protection.



Service the pre-cleaner every four hours of operation. Service by gently shaking excess sawdust and debris from the foam piece.



Clean the air filter (air cleaner element) and pre-cleaner (element wrapper) every eight hours of operation. See the engine manual for further instructions.



Replace the air filter (cleaner) every 200 hours of operation.



Replace the pre-cleaner (element wrapper) every 2000 hours of operation.

### 3.2 Engine Oil & Filter



Check the oil level every 8 hours of operation. Add oil as necessary. See the engine manual for oil viscosity and grade recommendations.



**IMPORTANT!** During initial break-in, change the oil and the oil filter after the first 50 hours and every 150-200 hours thereafter. Continue to check oil level every 8 hours of operation and refill as necessary.



**NOTE:** Engine in factory is filled with 5W/40 Shell Helix Ultra, full synthetic oil.

### 3.3 Air Cooling System



Wash the engine or brush off sawdust and debris every 50 hours of operation. Clean the grass screen, cooling fins, and external surfaces. Remove any dust, dirt or oil. See engine manual for further instructions.

### 3.4 Fuel Filter



Replace the fuel filter every 100 hours of operation.

### 3.5 Miscellaneous Maintenance



Inspect the spark plugs every 100 hour of operation. Remove any deposits and adjust gap if necessary. See engine manual for further information.

### 3.6 Drive Belt Adjustment



**WARNING!** Do not for any reason adjust the engine drive belts or belt support bracket with the engine running. Doing so may result in serious injury.



Check the drive belt tension after the first 20 hours, and every 50 hours thereafter.

The drive belt tension should be adjusted with the tensioner handle engaged (in the up position), by moving the engine assembly on the engine mount plate. To make the adjustment, perform the following steps:

1. Loosen the engine mounting bolts and the jam nuts.
2. Using the adjustment bolts, shown in the figure below, adjust the belt tension to approximately 11 mm deflection with 7.2 kG of deflection force.
3. Tighten the jam nuts and the engine mounting bolts.

# 3 Maintenance

## Drive Belt Adjustment

See Figure 3-1.

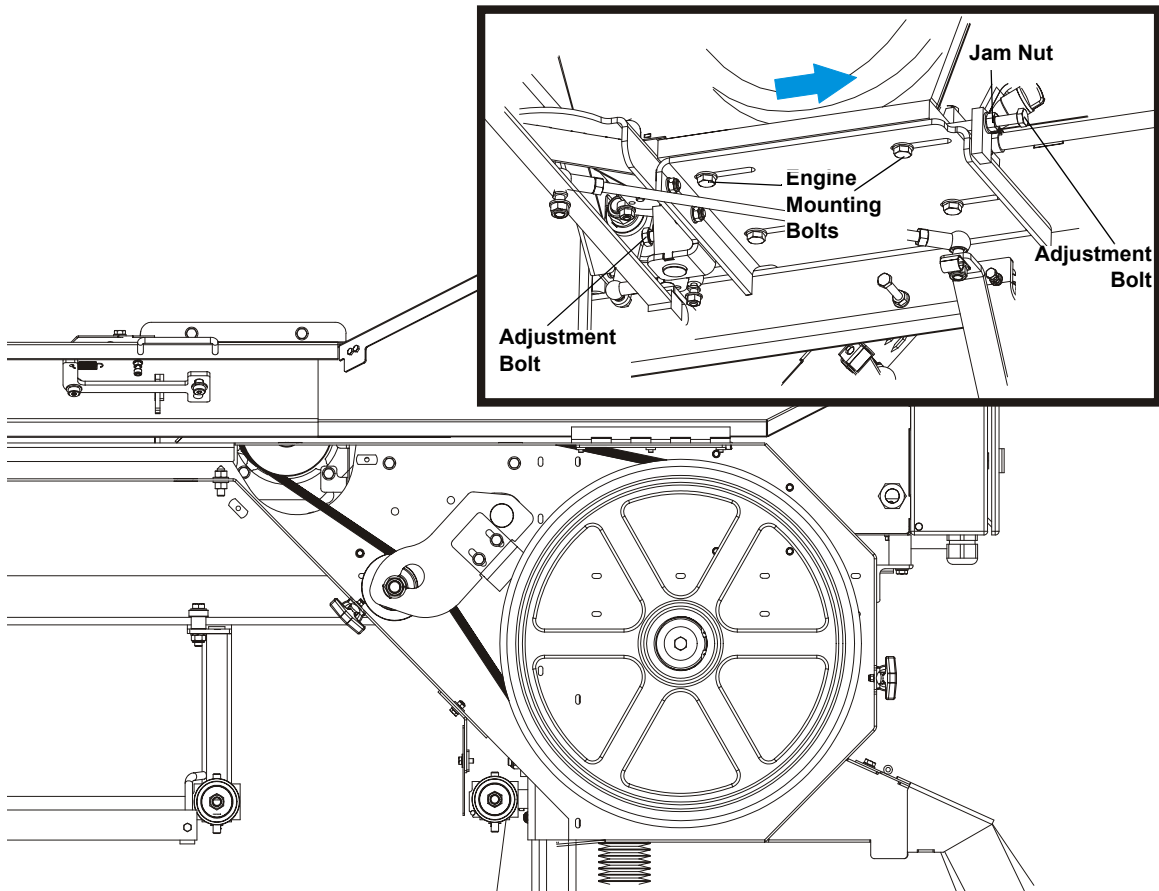

FIG. 3-1

Periodically check all belts for wear. Replace any damaged or worn belts as needed.



### 3.7 RPM Adjustments



**WARNING!** Remove the blade before performing any engine service. Failure to do so may result in serious injury.



Check the RPM with a tachometer after the first 20 hours of operation and every 200 hours thereafter. High-end RPM should be 3650 ( $\pm 100$ ) RPM and low-end RPM should be 1200 (not to exceed 1500).

Before checking the RPM, make sure belt and brake strap tension are correct (See Sawmill Maintenance).

1. Start the engine to measure the low-end RPM.

Make sure that the throttle linkage is not affecting the engine RPM while the clutch/brake handle is disengaged. Make sure the cable is not bent or kinked. Refer to the engine manual to adjust the low-end RPM.

2. Engage the clutch handle to throttle the engine and measure the high-end RPM. Readjust the throttle linkage if necessary to increase or reduce the high-end engine speed.

**See Figure 3-2.** The engine should start to throttle as soon as you start moving the clutch handle down. If the engine dies instead, restart the engine and adjust the throttle linkage as far as possible without affecting low-end RPM. **NOTE:** A properly adjusted throttle will extend the cable spring 1/4" to 3/8" (6.4 - 9.5 mm) when running and have a slight amount of slack in the cable when idling.

## SECTION 4 REPLACEMENT PARTS

### 4.1 How To Use The Parts List

- Use the table of contents or the index to locate the assembly that contains the part you need.
- Go to the appropriate section and locate the part in the illustration.
- Use the number pointing to the part to locate the correct part number and description in the table.
- Parts shown indented under another part are included with that part.
- Parts marked with a diamond (◆) are only available in the assembly listed above the part.

See the sample table below. Sample Part #A01111 includes part F02222-2 and subassembly A03333. Subassembly A03333 includes part S04444-4 and subassembly K05555. The diamond (◆) indicates that S04444-4 is not available except in subassembly A03333. Subassembly K05555 includes parts M06666 and F07777-77. The diamond (◆) indicates M06666 is not available except in subassembly K05555.

| <b>4.2 Sample Assembly</b> |  |           |      |   |
|----------------------------|--|-----------|------|---|
| REF                        | DESCRIPTION (◆ Indicates Parts Available In Assemblies Only)         | PART #    | QTY. |   |
|                            | <b>SAMPLE ASSEMBLY, COMPLETE (INCLUDES ALL INDENTED PARTS BELOW)</b> | A01111    | 1    |   |
| 1                          | Sample Part  | F02222-22 | 1    |   |
|                            | Sample Subassembly (Includes All Indented Parts Below)               | A03333    | 1    |   |
| 2                          | Sample Part (◆ Indicates Part Is Only Available With A03333)         | S04444-4  | 1    | ◆ |
|                            | Sample Subassembly (Includes All Indented Parts Below)               | K05555    | 1    |   |
| 3                          | Sample Part (◆ Indicates Part Is Only Available With K05555)         | M06666    | 2    | ◆ |
| 4                          | Sample Part  | F07777-77 | 1    |   |

#### To Order Parts:

- From Europe call our European Headquarters and Manufacturing Facility in Kolo, Poland at **+48-63-2626000**. From the continental U.S., call **1-800-448-7881** to order parts. Have your customer number, vehicle identification number, and part numbers ready when you call.
- From other international locations, contact the Wood-Mizer distributor in your area for parts.

### 4.3 Engine Assembly

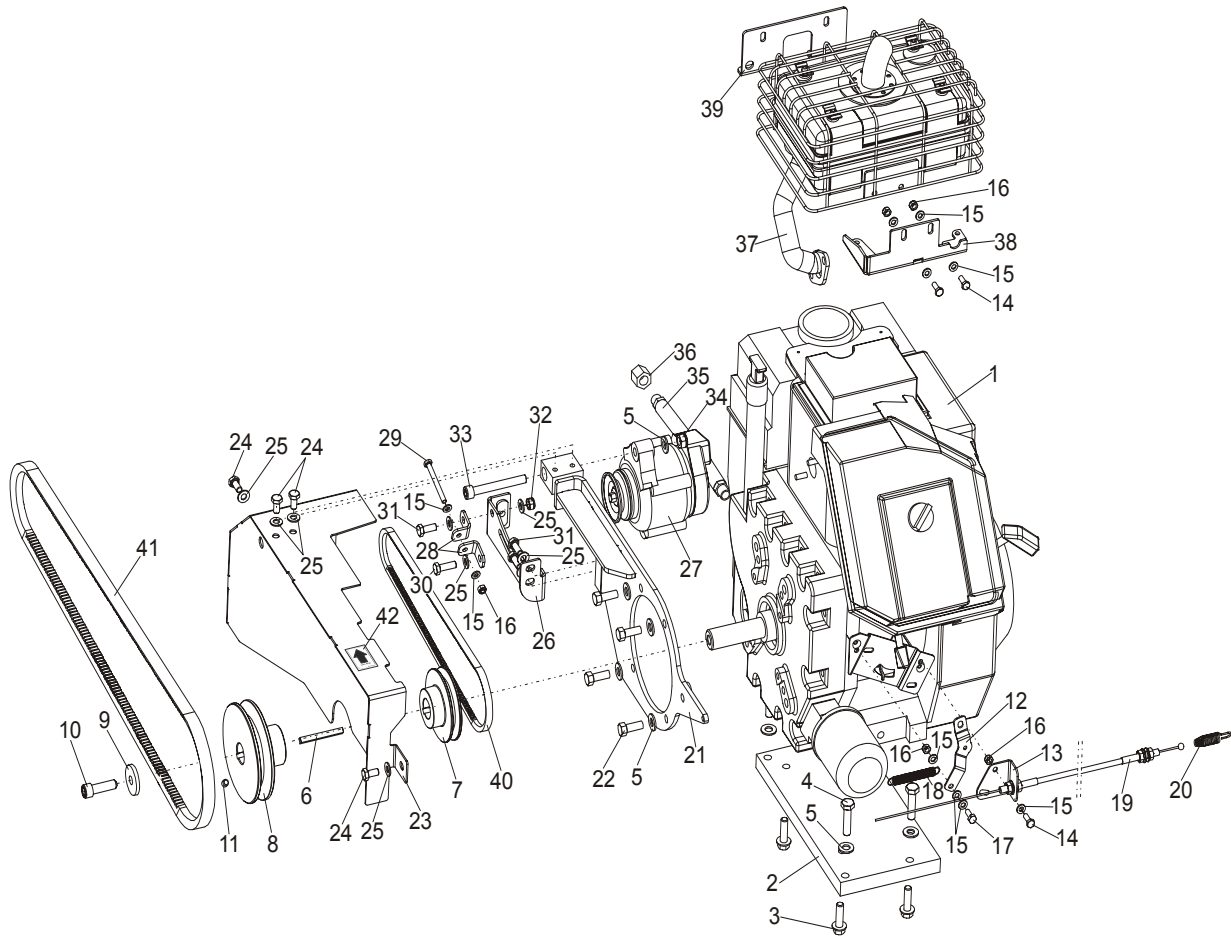

| REF | DESCRIPTION (◆ indicates parts available in assemblies only) | PART #     | QTY. |  |
|-----|--|------------|------|--|
|     | <b>ENGINE ASSY, LT15G15 KOHLER</b>                           | 096971     | 1    |  |
| 1   | Engine KOHLER 15HP, CH15ST w/electric start                  | 096443     | 1    |  |
|     | Filter, Kohler Air #47-083-01                                | 014718     | 1    |  |
|     | Pre-Cleaner, Kohler Air #52-083-01                           | 014719     | 1    |  |
|     | Filter, Kohler Oil #52-050-02                                | 014717     | 1    |  |
|     | Plug, Kohler Spark #12-132-02 (Champion #RC12YC)             | P12757     | 1    |  |
|     | Filter, Kohler In-Line Fuel #25-050-02                       | 014720     | 1    |  |
| 2   | Plate, G15 Engine Mounting                                   | 095297     | 1    |  |
| 3   | Bolt, 3/8-16 x 1 1/4   | F05007-131 | 4    |  |
| 4   | Bolt, M10x40-8.8 Hex Head Full Thread Zinc                   | F81003-16  | 4    |  |
| 5   | Washer, 10,5 Flat Zinc                                       | F81055-1   | 9    |  |
| 6   | Key, 6,35 x 6,35 x 63,5, Parallel Zinc                       | 095334     | 1    |  |

## 4

## Replacement Parts

## Engine Assembly

|    |  |                      |    |  |
|----|--|----------------------|----|--|
| 7  | Pulley, 30A Alternator                               | 095267-1             | 1  |  |
| 8  | Pulley, D10,G13,G15 - Engine Zinc                    | 096447-1             | 1  |  |
| 9  | Washer, G13 Kohler Engine, Zinc                      | 088059-1             | 1  |  |
| 10 | Screw, 7/16-20x1 1/2 SHC                             | F05007-55            | 1  |  |
| 11 | Screw, M8x8-33H-Hex Socket Set Flat Point            | F81014-1             | 1  |  |
| 12 | Handle, Throttle Zinc                                | 095300-1             | 1  |  |
| 13 | Bracket, Throttle Cable Zinc                         | 095301-1             | 1  |  |
| 14 | Bolt, M6x16-8.8-Hex Head Full Thread Zinc            | F81001-32            | 3  |  |
| 15 | Washer, 6,4 Flat Zinc                                | F81053-1             | 10 |  |
| 16 | Nut, M6-8-B-Hex Nylon Zinc Lock                      | F81031-2             | 5  |  |
| 17 | Bolt, Throttle Cable Clamp Zinc-Plated               | 088120-1             | 1  |  |
| 18 | Spring, Extension 3/8X3                              | 014818               | 1  |  |
| 19 | Cable, D10, LT15 Throttle                            | 095308               | 1  |  |
| 20 | Spring, 35 x 9,5 x 1,6 Extension                     | 097443               | 1  |  |
| 21 | Bracket, LT15/G15 Alternator                         | 095302-1             | 1  |  |
| 22 | Screw, 3/8-16x1,HHC GR8                              | F05007-7             | 4  |  |
| 23 | Cover, LT15/G15 Alternator                           | 095324-1             | 1  |  |
| 24 | Screw, M8x16 -8.8-B-Hex Head Full Thread Zinc        | F81002-20            | 4  |  |
| 25 | Washer, 8,4-Flat Zinc                                | F81054-1             | 9  |  |
| 26 | Bracket, "Denso" 30A Alternator                      | 095268-1             | 1  |  |
| 27 | Alternator D42                                       | 089661               | 1  |  |
| 28 | Tensioner, 30A Alternator Belt                       | 095296-1             | 1  |  |
| 29 | Bolt, M6x60-8.8-Hex Head Full Thread Zinc            | F81001-9             | 1  |  |
| 30 | Bolt, M8x25-8.8-B-Hex Head Full Thread Zinc          | F81002-5             | 1  |  |
| 31 | Bolt, M8x20-8.8-B-Hex Head Full Thread Zinc          | F81002-4             | 3  |  |
| 32 | Nut, M8-8-B-Hex Nylon Zinc Lock                      | F81032-2             | 1  |  |
| 33 | Screw, M10x80 -8.8 Hex Socket Head Cap Zinc          | F81003-69            | 1  |  |
| 34 | Nut, M10-8-B -Hex Nylon Zinc Lock                    | F81033-1             | 1  |  |
| 35 | Hose, Rubber   | P10082               | 1  |  |
| 36 | Cap, 3/8 Pipe Galvanize                              | P04332               | 1  |  |
| 37 | Muffler, G13 Engine                                  | 088313-1             | 1  |  |
| 38 | Bracket Weldment, G13 Muffler Support Ptd            | 088310-1             | 1  |  |
| 39 | Bracket, G15 for LT15 Muffler                        | 088704-1             | 1  |  |
| 40 | Belt, AVX10x838La                                    | 095329               | 1  |  |
| 41 | <b>BELT, 17BX 2250 REF. BX87, 2210Li (GOOD-YEAR)</b> | 097448               | 1  |  |
| 42 | <b>DECAL, 3600 RPM ENGINE DIRECTION</b>              | S20097A <sup>1</sup> | 1  |  |

<sup>1</sup> Includes in 099421 - LT15DC Pictographic Decal Kit.



### 4.4 Brake/Belt Tensioner Assembly

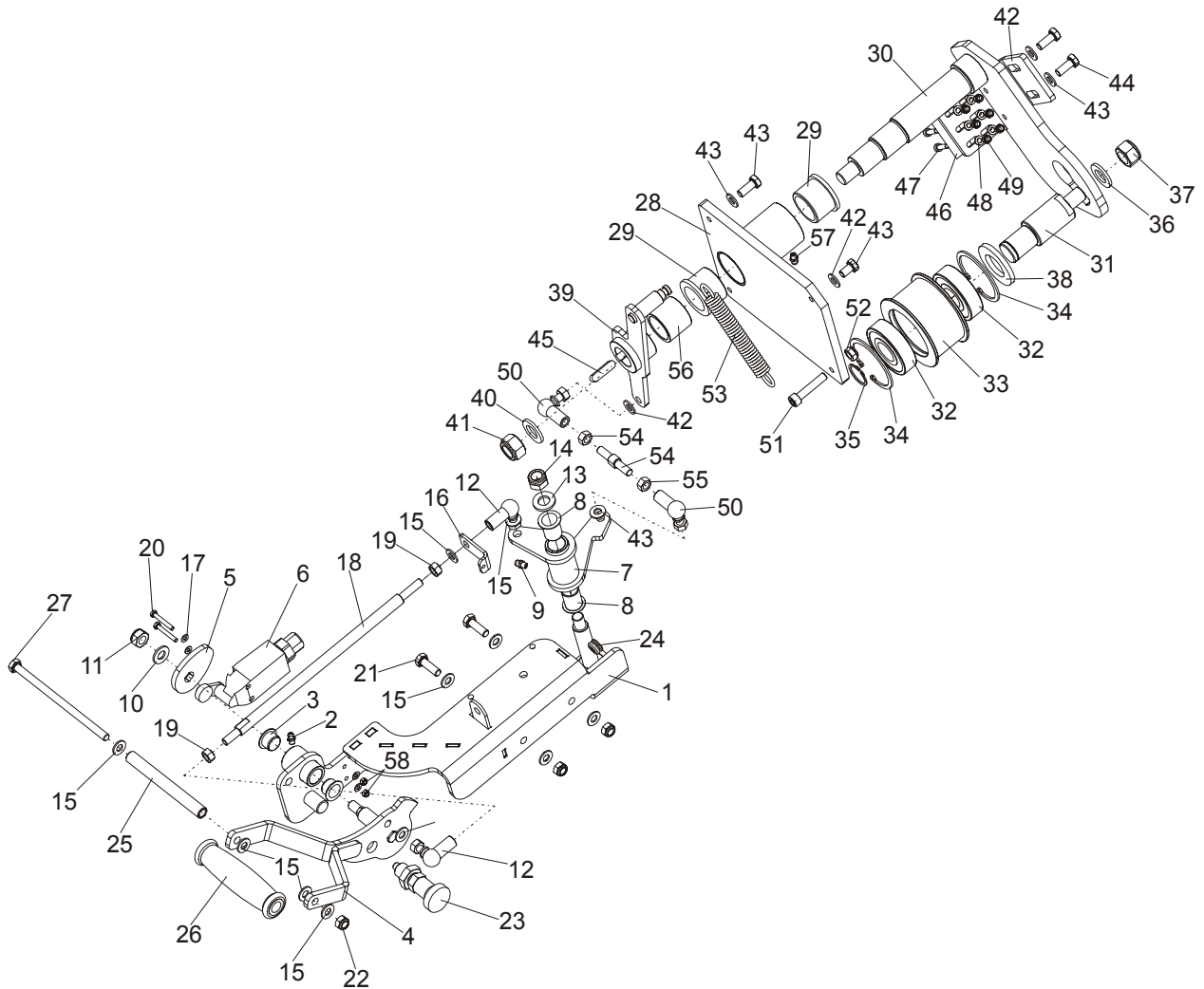

| REF | DESCRIPTION (◆ Indicates Parts Available In Assemblies Only ) | PART #   | QTY. |
|-----|---|----------|------|
|     | <b>BELT TENSIONER &amp; BRAKE ASSEMBLY</b>                    | 096448   | 1    |
|     | HANDLE, TENSIONER AND BRAKE COMPLETE                          | 097436   | 1    |
|     | Plate, Tensioner/Brake Handle Complete                        | 097437   | 1    |
| 1   | Plate, Tensioner/Brake Handle                                 | 097438-1 | 1    |
| 2   | Fitting, M6 Type A Grease                                     | 086280   | 1    |
| 3   | Bushing, GFM - 1618-12 Igus                                   | 091455   | 2    |
| 4   | Grip, Tensioner/Brake Handle                                  | 095318-1 | 1    |
| 5   | Cam, LT15 Limit Switch Zinc                                   | 096969-1 | 1    |
| 6   | Limit Switch, EVN2000 A                                       | 091742   | 1    |
|     | Angle Lever, Complete   | 097432   | 1    |

# 4

## Replacement Parts

### Brake/Belt Tensioner Assembly

|    |   |           |    |  |
|----|---|-----------|----|--|
| 7  | Lever, Angle                                | 097433-1  | 1  |  |
| 8  | Bushing, GFM 1719-25                        | 094142    | 2  |  |
| 9  | Fitting, M6 Type A Grease                   | 086280    | 1  |  |
| 10 | Washer, 10,5 Flat Zinc                      | F81055-1  | 1  |  |
| 11 | Nut, M10-8-B Hex Nylon Zinc Lock            | F81033-1  | 1  |  |
| 12 | Pivot, FI 13-M8 (T17628-ULMER) Angle        | 095285    | 2  |  |
| 13 | Washer, 13 Flat Zinc                        | F81056-1  | 1  |  |
| 14 | Nut, M12-8 Hex Nylon Zinc Lock              | F81034-2  | 1  |  |
| 15 | Washer, 8,4 Flat Zinc                       | F81054-1  | 11 |  |
| 16 | Plate, Tensioner                            | 097442-1  | 1  |  |
| 17 | Washer, 4,3 Flat Zinc                       | F81051-2  | 4  |  |
| 18 | Pusher, M8 Long                             | 097444-1  | 1  |  |
| 19 | Nut, M8-8-B Hex Zinc                        | F81032-1  | 2  |  |
| 20 | Bolt, M4x30 8.8 Hex Head Full Thread Zinc   | F81011-5  | 2  |  |
| 21 | Bolt, M8x25-8.8-B Hex Head Full Thread Zinc | F81002-5  | 2  |  |
| 22 | Nut, M8-8-B Hex Nylon Zinc Lock             | F81032-2  | 3  |  |
| 23 | Pin, 45308DNW Detent                        | 089939    | 1  |  |
| 24 | Seal Wire, Rubber Inside Dia 6mm            | 085338    | 1  |  |
| 25 | Axle, Grip Rotation                         | 097698-1  | 1  |  |
| 26 | Knob, 1.135/120-13 Crank Handle             | 097696    | 1  |  |
| 27 | Bolt, M8x150-8.8 Hex Head Zinc              | F81002-36 | 1  |  |
|    | TENSION ROLLER W/BRAKE, COMPLETE            | 097446    | 1  |  |
| 28 | Mount Wldmt, Tensioner Shaft Ptd            | 091112-1  | 1  |  |
| 29 | Bushing, MFM-3240-30 (IGUS)                 | 088461    | 2  |  |
| 30 | Shaft, Belt Tensioner                       | 096451-1  | 1  |  |
|    | Roller, Tension Complete                    | 097832    | 1  |  |
| 31 | Axle, Belt Tension Wheel Zinc               | 100232-1  | 1  |  |
| 32 | Bearing Wheel, Idle Side 6305 2RS NSK.      | P08066    | 2  |  |
| 33 | Wheel, LT15 Belt Tension Zinc               | 087671-1  | 1  |  |
| 34 | Ring, 62W Inside Spring Retaining           | F81090-1  | 2  |  |
| 35 | Ring, 25Z Outside Retaining                 | F81090-22 | 1  |  |
| 36 | Washer, 17 Flat Zinc                        | F81058-1  | 1  |  |
| 37 | Nut, M16-8-Hex Nylon Zinc Lock              | F81036-2  | 1  |  |
| 38 | Washer, Tension Roller Axle, Zinc           | 100237-1  | 1  |  |
| 39 | Lever, Tensioner Double-Arm                 | 096449-1  | 1  |  |
| 40 | Washer, 17 Flat Zinc                        | F81058-1  | 1  |  |
| 41 | Nut, M16-8-Hex Nylon Zinc Lock              | F81036-2  | 1  |  |
| 42 | Bracket, Brake Block Mount Ptd              | 091248-1  | 1  |  |
| 43 | Washer, 8,4-Flat Zinc                       | F81054-1  | 7  |  |
| 44 | Bolt, M8x20-5.8-Hex Head Full Thread Zinc   | F81002-1  | 5  |  |
| 45 | Key, A8x7x32 Parallel                       | 088564    | 1  |  |
| 46 | Block, F9273 123 Drive Belt Tensioner Brake | 092111    | 2  |  |
| 47 | Screw, M5x25-8.8-Hex Socket Head Cap Zinc   | F81000-7  | 6  |  |
| 48 | Washer, 5,3 Flat Zinc                       | F81052-1  | 6  |  |
| 49 | Nut, M5-8-DIN 985 Zinc                      | F81030-2  | 6  |  |
| 50 | Pivot, FI 13-M8 (T17628-ULMER) Angle        | 095285    | 2  |  |

|           |   |           |   |  |
|-----------|---|-----------|---|--|
| <b>51</b> | Screw, M8x40 -8.8- Hex Socket Head Cap Zinc | F81002-29 | 1 |  |
| <b>52</b> | Nut, M8-8-B-FeZn5 Hex Nylon Zinc Lock       | F81032-2  | 1 |  |
| <b>53</b> | Spring, FI 1,9 x fi 14,2 x 104              | 091865    | 1 |  |
| <b>54</b> | Pusher, Short Zinc                          | 097445-1  | 1 |  |
| <b>55</b> | Nut, M8-8-B-Hex Zinc                        | F81032-1  | 2 |  |
| <b>56</b> | Bushing, Tensioner Zinc                     | 097447-1  | 1 |  |
| <b>57</b> | Fitting, M6 Type A Grease                   | 086280    | 1 |  |
| <b>58</b> | Nut, M4-B-Hex Zinc                          | F81029-1  | 2 |  |

