

Wood-Mizer®

Replacement Parts Manual

LT15SC S2-4 G15	rev. A1.00
LT15SC M2-4 G15	rev. A1.00
LT15SC S2-4 D10	rev.A1.00
LT15SC M2-4 D10	rev. A1.00



Safety is our #1 concern! Read and understand all safety information and instructions before operating, setting up or maintaining this machine.

Form #799

Table of Contents

Section-Page

SECTION 1	GENERAL INFORMATION	1-1
1.1	How To Use The Parts List	1-1
1.2	Sample Assembly	1-1
SECTION 2	FRAME PARTS	2-1
2.1	Log Side Support Assembly	2-1
2.2	Bed Connecting Hardware	2-2
2.3	Stationary Leg Kit	2-3
2.4	Outrigger Leg Kit	2-4
2.5	Log Clamp Assembly	2-5
2.6	Auxiliary Bed Rail Assembly	2-6
2.7	Log Wedge, Loading Ramps, & Cant Hook (Optional).....	2-7
2.8	Bed Extension.....	2-8
2.9	”M” Type Frame Bed Section	2-9
2.10	”S” Type Frame Bed Section	2-9
2.11	Additional Bed Frame Section with Stationary Legs	2-11
2.12	Additional Bed Frame Section with Outrigger Legs	2-11
SECTION 3	LEG ASSEMBLIES	3-1
3.1	”S” Frame Legs	3-1
3.2	”M” Frame Legs	3-2
SECTION 4	BLADE GUIDE ROLLERS & ARM	4-1
4.1	Blade Guide Assembly, Idle Side.....	4-1
4.2	Blade Guide Assembly, Drive Side.....	4-2
4.3	Blade Guide Roller Guard	4-4
4.4	Blade Guide Arm w/Lever	4-5
SECTION 5	BLADE WHEELS & TENSIONER	5-1
5.1	Blade Wheel Assembly, Drive Side	5-1
5.2	Blade Wheel Assembly, Idle Side	5-2
5.3	Blade Tensioner Assembly	5-3
SECTION 6	SAW HEAD	6-1
6.1	Blade Housing Cover	6-1
6.2	Water Lube Assembly	6-3
6.3	Blade Lube System (not available in EC version).....	6-4
6.4	LT15DC Saw Head Decals	6-5
6.5	Control Box (Power Feed).....	6-7
6.6	Electric Box, LT15 DC.....	6-9
6.7	D10 & G15 Engine Mounting Plate	6-10
6.8	Battery Box	6-11

Table of Contents

Section-Page

SECTION 7	FEED SYSTEM	7-1
7.1	Feed Crank Assembly.....	7-1
7.2	Track Rail, Rollers & Travel Pins	7-3
7.3	Feed Rope, V-Groove Rollers & Brackets	7-5
7.4	Power Feed System - Optional	7-6
SECTION 8	UP/DOWN SYSTEM	8-1
8.1	Up/Down Assembly, DC.....	8-1
8.2	Service Kit, LT15 Up/Down System.....	8-4
8.3	Slide Pads & Blade Height Scale Indicator.....	8-5
8.4	Blade Height Scale & Up/Down Limit Switches	8-7
8.5	Blade Height Scale (Optional).....	8-9

Getting Service

Wood-Mizer is committed to providing you with the latest technology, best quality and strongest customer service available on the market today. We continually evaluate our customers' needs to ensure we're meeting current wood-processing demands. Your comments and suggestions are welcome.

General Contact Information

From Europe call your local distributor or our European Headquarters and Manufacturing Facility in Koło, Nagórna 114 St, Poland at **+48-63-2626000**. From the continental U.S., call our U.S. Headquarter 8180 West 10th St.Indianapolis, IN 46214, toll-free at **1-800-525-8100**. Ask to speak with a Customer Service Representative. Please have your machine identification number and your customer number ready when you call. The Service Representative can help you with questions about the operation and maintenance of your machine. He also can schedule you for a service call.

Office Hours:

Country	Monday - Friday	Saturday	Sunday
Poland	7 a.m.- 3 p.m.	Closed	Closed
US	8 a.m.- 5 p.m.	8 a.m.- 12 p.m	Closed

Please have your vehicle identification number and your customer number ready when you call.

Wood-Mizer will accept these methods of payment:

- Visa, Mastercard, or Discover
- COD
- Prepayment
- Net 15 (with approved credit)

Be aware that shipping and handling charges may apply. Handling charges are based on size and quantity of order.

Technical data are subject to change without prior notice.

Actual product may differ from product images. Some illustrations show machines with optional equipment.

Branches & Authorized Sales Centers Wood-Mizer Locations (North and South America)

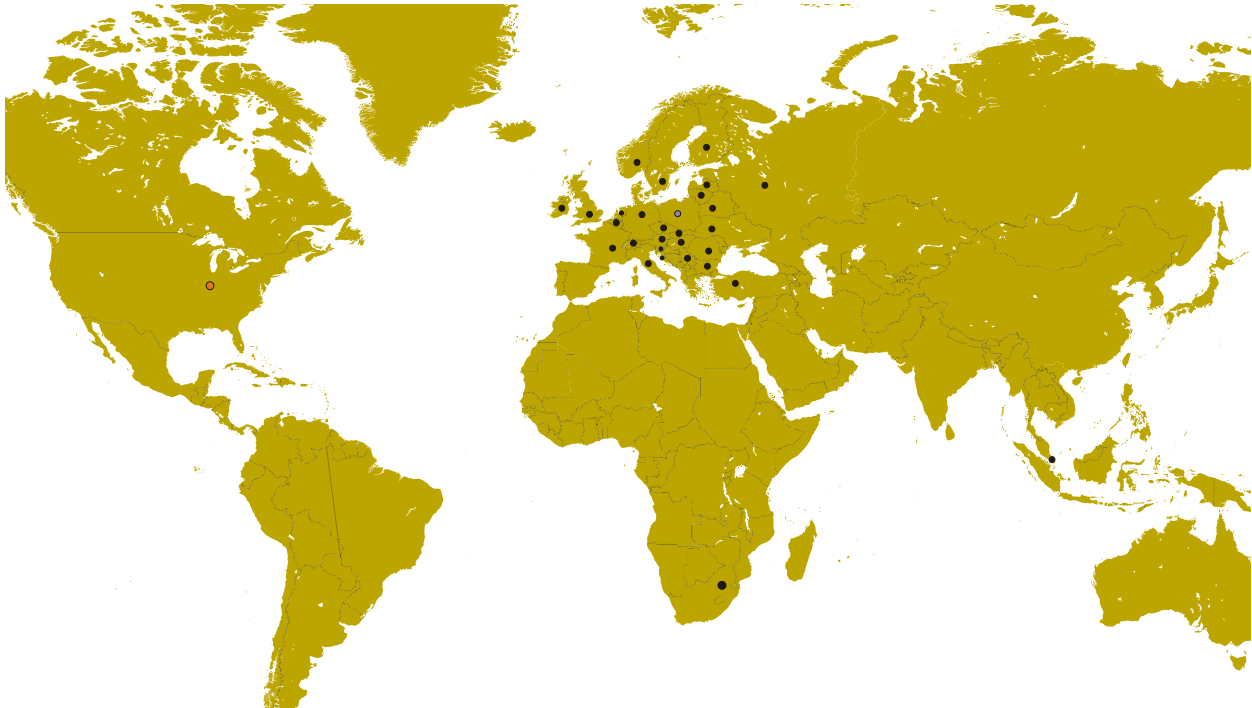

EUROPE		UNITED STATES
<p>European Headquarters Wood-Mizer Industries Sp. z o.o. Nagórna 114, 62-600 Kolo, Poland Tel.: +48-63-26-26-000 Fax: +48-63-27-22-327 www.woodmizer.eu</p>		<p>World Headquarters Wood-Mizer LLC 8180 West 10th Street Indianapolis, Indiana 46214-2400, USA Tel.: +1-317-271-1542 Fax: +1-317-273-1011 www.woodmizer.com</p>
<p>BELARUS MOST-GRUPP Siemashko 15, k.3 Minsk 2200116 Tel.: +375-17-270-90-08 Fax: +375-17-270-90-08 GSM: +375-29-649-90-80 e-mail: most-by@mail.ru</p>	<p>SWITZERLAND Stefan Wespi Maschinen u. Geräte Spezialarbeiten GmbH Eichstraße 4 6353 Weggis Tel.: +41-(0)41 - 3900312 GSM: +41-(0)79 - 9643594 info@mobilsaegen.ch</p>	<p>RUSSIA Dariusz Mikołajewski OOO WOOD-MIZER INDUSTRIES 141031, Moscow Reg., Mytishenski raj., pos. Veshki, Zavodskaja str., 3B Tel.Fax: +7(495) 788-72-35 Tel.Fax: +7(495) 641-51-60 e-mail: dariuszm@woodmizer-moscow.ru</p>
<p>BULGARIA Kalin Simeonov Ecotechproduct 38 Star Lozenski pat str. Sofia 1186 Tel.: +359-2-462-7035 Tel.: +359-2-963-1656 Tel./Fax : +359-2-979-1710 Kalin Simeonov GSM: +3592-963-2559 e-mail: office@ecotechproduct.com</p>	<p>HUNGARY Wiktor Turoczy Wood-Mizer Hungary K.F.T. Szonyi Ut 67., 2921 Komárom Tel./Fax: +36-34-346-255 e-mail: woodmizer@woodmizer.hu</p>	<p>RUSSIA Far East Wladimir Glazaczew "WM Service" Krasnoretchenskaya Str.111 680006 Khabarovsk Tel./Fax: +7-914-541-1183 e-mail: wms-khv@mail.ru</p>

<p>CROATIA Krešimir Pregernik Pregimex d.o.o. S. Batušićeva 31, 10090 Zagreb Tel./Fax: +3851-38-94-668 Krešimir Pregernik GSM: +3851-98-207-106 e-mail: Kresimir.Pregernik@gmail.com</p>	<p>ITALY Pasquale Felice Wood-Mizer Italia Srl Cda. Capoiaccio SN 86012 Cercemaggiore Campobasso Tel./Fax: +39-0874-798-357 GSM: +39-333-281-03-79 e-mail: wmitaliasrl@gmail.com</p>	<p>SERBIA Dragan Markov Wood-Mizer Balkan d.o.o. Svetosavska GA 3/3; P. Fah 25 23 300 Kikinda Tel./Fax: +381-230-25-754 Tel./Fax: +381-230-23-567 GSM: +381-63-568-658 e-mail: office@woodmizer.co.yu</p>
<p>CZECH REPUBLIC Miroslav Greill Wood-Mizer CZ s.r.o. Osvaldova 91 339 01 Klatovy-Luby Tel./Fax: +420-376-312-220 Fax: +420-376-319-011 Miroslav Greill GSM: +420-723-580-799 e-mail: greill@woodmizer.cz</p>		<p>SLOVAKIA Wiktor Turoczy Wood-Mizer Danubia s.r.o. Hadovce 5, 94501 Komárno Tel.: +421-35-77-40-316 Fax: +421-35-7740-326 GSM: +421-905-930-972 e-mail: woodmizer@woodmizer.sk</p>
<p>CZECH REPUBLIC Lubomir Kudlik Wood-Mizer Moravia Sovadinova 6 69002 Breclav Tel./Fax: +420-519-322-443 Lubomir Kudlik GSM: +420-602-734-792 e-mail: info@wood-mizer.net</p>	<p>LATVIA Vilmars Jansons OBERTS Ltd Gaujas str. 32/2 LV-2167 Marupe, Rigas Raj. Tel.: +371-7-810-666 Fax: +371-7-810-655 Vilmars Jansons GSM: +371-92-06-966 Andris Orols GSM: +371-28-33-07-90 e-mail: andris@oberts.lv</p>	<p>TURKEY Er-Ka Ahsap Profil Kerestecilik San. ve Tic. Ltd. Sti. Adana Keresteciler Sitesi 191 sk No.41 ADANA Tel.: +90-322-346-15-86 Fax: +90-322-345-17-07 GSM: +90-533-363-18-44 e-mail: info@erkaahsap.com.tr</p>
<p>FINLAND Howard Blackbourn Oy Falkberg Jordbruk Ab Falkintie 220 25610 Ylonkyla Tel.: +358-2732-2253 Fax: +358-2732-2263 Howard Blackbourn GSM: +358-440-424-339 e-mail: falkberg@woodmizer.fi</p>	<p>LITHUANIA Andrius Zuzevicius UAB Singlis Savanoriu pr. 187, 2053 Vilnius Tel.: +370-5-2-32-22-44 Fax: +370-5-2-64-84-15 GSM: +370-620-28-645 e-mail: andrius.z@singlis.lt</p> <p>Dmitrij Gaiduk GSM: +370-69-84-51-91 e-mail: dmitrijus.g@singlis.lt</p>	<p>UKRAINE Ivan Vinnicki MOST UKRAINA bul. Myru 3, Bajkivtsi Ternoplskyj r-j Ternopolska oblast 47711 Ukraine Tel/Fax: +38 (0352) 52 37 74 GSM: +38 (067) 352 54 34 GSM: +38 (067) 674 50 68 E-mail: most-ukraina@ukr.net</p>
<p>FRANCE Tizoc Chavez Wood-Mizer France 556 chemin des Embouffus, ZAC des Basses Echarrieres 38440 SAINT JEAN DE BOURNAY Tel: +33-4 74 84 84 44 GSM: +33-607 52 02 82 Mail: tchavez@woodmizer.fr</p>	<p>NORWAY Odd Edvoll Wood-Mizer Nordic AS Vardelia 17, 2020 Skedsmokorset Tel.: +47-63-87-49-89 Fax: +47-63-87-37-66 GSM: +47-930-42-335 e-mail: odd.edvoll@woodmizer.no</p> <p>e-mail: firmapost@woodmizer.no</p>	<p>UNITED KINGDOM & IRELAND Wood-Mizer UK Hopfield Barn Kenward Road, Yalding Kent ME18 6JP, UK Tel.: +44-1622-813-201 Fax: +44-1622-815-534 e-mail: info@woodmizer.co.uk</p>
<p>SLOVENIA Jan Fale FAMTEH d.o.o. Gacnikova pot 2, 2390 Ravne na Koroskem Tel.: +386-2-62-04-232 Fax: +386-2-62-04-231 Jan Fale GSM: +386-2-62-04-230 e-mail: jan.fale@famteh.si</p> <p>Matjaz Kolar Tel.: +386-2-62-04-232 GSM: +386-31-775-999 e-mail: matjaz.kolar@famteh.si</p>		

<p>GERMANY Klaus Longmuss Wood-Mizer Sägewerke GmbH Dorfstraße 5, 29485 Schletau Tel.: +49-5883-9880-10 Fax: +49-5883-9880-20 e-mail: info@woodmizer.de</p> <p>Klaus Longmuss Tel.: +49-5883-9880-12 GSM: +49-17-298-55-892 e-mail: KLongmuss@woodmizer.de</p>	<p>Subagent: SWEDEN Kjell Larsson Mekwood AB Slingan 14, 812 41 Gästrike-Hammarby Tel.: +46-290-515-65 Kjell Larsson GSM: +46-706-797-965 e-mail: kjell.larsson@mekwood.se</p>	<p>IRELAND Wood-Mizer Ireland Stephen Brennan Cum Lahardane Ballina County Mayo Tel:+353 96 51345</p> <p>E-mail: brennanmill@ericom.net</p>
<p>Subagents: DENMARK Brian Jensen Arnborgvej 9, 7330 Brande- Fasterholt Tel.: +45-971-88-265 Fax: +45-971-88-266</p> <p>Brian Jensen GSM: +45-23-49-5828 e-mail: Fasterholt-Savvaerk@Mail.Tele.dk</p>	<p>ROMANIA Adrian Echert SC WOOD-MIZER RO SRL TRANSILVANIEI Nr. 5 Sibiu, Cisnadia 555300 Tel./Fax: : +40-369-405-433 GSM: +40-745-707-323 e-mail: aechert@woodmizer.ro</p>	<p>Regional Manager - Asia Wood-Mizer Asia Pte Ltd. James Wong Tel: +65 81216910 Fax: +65 6283 8636 WWW: www.woodmizerasia.com E-mail: jwong@woodmizerasia.com</p>
<p>Netherlands Chris Dragt Lange Brink 77d, 7317 BD Apeldoorn Tel.: +31-55312-1833 Fax: +31-55312-2042 e-mail: Info@dragtbosbouw.nl</p>	<p>Subagent: ROMANIA M. Echert S.C. Echert Comprod s.r.l Str. Schitului Nr. 6, Apt.7 etajul-1 725 70 Vatra Dornei, Romania Tel./Fax: +40-230-374-235 Tel. : +40-740-35-35-74</p>	<p>Regional Manager - Africa Wood-Mizer Africa Jean-Jacques Oelofse UNIT 3, LEADER PARK, NO: 20 CHARIOT ROAD STORMILL, EXT 5, Roodepoort, Johannesburg Tel: +27 011 473 1313 Fax: +27 011 473 2005 Jean-Jacques Oelofse E-mail: jjoelofse@woodmizerafrika.com Jean-Jacques Oelofse Skype:jean.jacques.pierre.oelofse</p>

USA World Headquarters

Serving North & South America, Oceania, East Asia

Wood-Mizer LLC
 8180 West 10th Street
 Indianapolis, IN 46214

Phone: 317.271.1542 or 800.553.0182
 Customer Service: 800.525.8100
 Fax: 317.273.1011
 Email: infocenter@woodmizer.com

Canadian Headquarters

Serving Canada

Wood-Mizer Canada
 396 County Road 36, Unit B
 Lindsay, ON K9V 4R3

Phone: 705.878.5255 or 877.357.3373
 Fax: 705.878.5355
 Email: ContactCanada@woodmizer.com

Brazil Headquarters

Serving Brazil

Wood-Mizer do Brasil
 Rua Dom Pedro 1, No: 205 Bairro: Sao Jose
 Ivoti/RS CEP:93.900-000

Tel: +55 51 9894-6461/ +55 21 8030-3338/ +55 51
 3563-4784
 Email: info@woodmizer.com.br

Europe Headquarters

Serving Europe, Africa, West Asia

Wood-Mizer Industries Sp z o.o.
 Nagorna 114
 62-600 Kolo, Poland

Phone: +48.63.26.26.000
 Fax: +48.63.27.22.327

Branches & Authorized Sales Centers

For a complete list of dealers, visit www.woodmizer.com

SECTION 1 GENERAL INFORMATION

1.1 How To Use The Parts List

- Use the index above to locate the assembly that contains the part you need.
- Go to the appropriate section and locate the part in the illustration.
- Use the number pointing to the part to locate the correct part number and description in the table.
- Parts shown indented under another part are included with that part.
- Parts marked with a diamond (◆) are only available in the assembly listed above the part.

See the sample table below. Sample Part #A01111 includes part F02222-2 and subassembly A03333. Subassembly A03333 includes part S04444-4 and subassembly K05555. The diamond (◆) indicates that S04444-4 is not available except in subassembly A03333. Subassembly K05555 includes parts M06666 and F07777-77. The diamond (◆) indicates M06666 is not available except in subassembly K05555.

1.2 Sample Assembly				
REF.	DESCRIPTION (◆ Indicates Parts Available In Assemblies Only)	PART #	QTY	
	Sample Assembly, Complete (Includes All Indented Parts Below)	A01111	1	
1	Sample Part	F02222-22	1	
	Sample Subassembly (Includes All Indented Parts Below)	A03333	1	
2	Sample Part (◆ Indicates Part Is Only Available With A03333)	S04444-4	1	◆
	Sample Subassembly (Includes All Indented Parts Below)	K05555	1	
3	Sample Part (◆ Indicates Part Is Only Available With K05555)	M06666	2	◆
4	Sample Part	F07777-77	1	

To Order Parts:

- From Europe call our European Headquarters and Manufacturing Facility in Kolo, Poland at **+48-63-2626000**. From the continental U.S., call our toll-free Parts hotline at **1-800-525-8100**. Have your customer number, vehicle identification number, and part numbers ready when you call. From other international locations, contact the Wood-Mizer distributor in your area for parts.

Office Hours:

Country	Monday - Friday	Saturday	Sunday
Poland	7-15	Closed	Closed
US	8 a.m.- 5 p.m.	8 a.m.- 12 p.m.	Closed



CAUTION! It is strongly recommended that only original spare parts be used.

SECTION 2 FRAME PARTS

2.1 Log Side Support Assembly

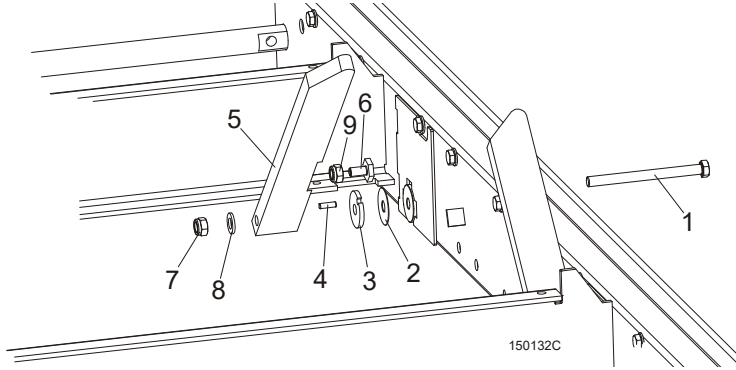

REF.	DESCRIPTION (◆ Indicates Parts Available In Assemblies Only)	PART #	QTY
1	BOLT, M12X140-8.8 HEX HEAD ZINC	F81004-35	1
2	WASHER, 33/64 X 1 3/4 X 1/32" NYLON	014972	1
3	WASHER, LT15 THICK SPACER	085981-1	1
	SUPPORT, LT15 LOG SIDE COMPLETE PAINTED	085982-1	1
4	PIN, H 6n6x20 60HRC ROLL	100472	1
5	PLATE, LT15 LOG SIDE SUPPORT	085980	1
6	BOLT, M10x20 SPECIAL	100076-1	1
7	NUT, M12-8 HEX NYLON ZINC LOCK	F81034-2	1
8	WASHER, 13 FLAT ZINC	F81056-1	1
9	NUT, M10-8-B HEX ZINC	F81033-3	1

2.2 Bed Connecting Hardware

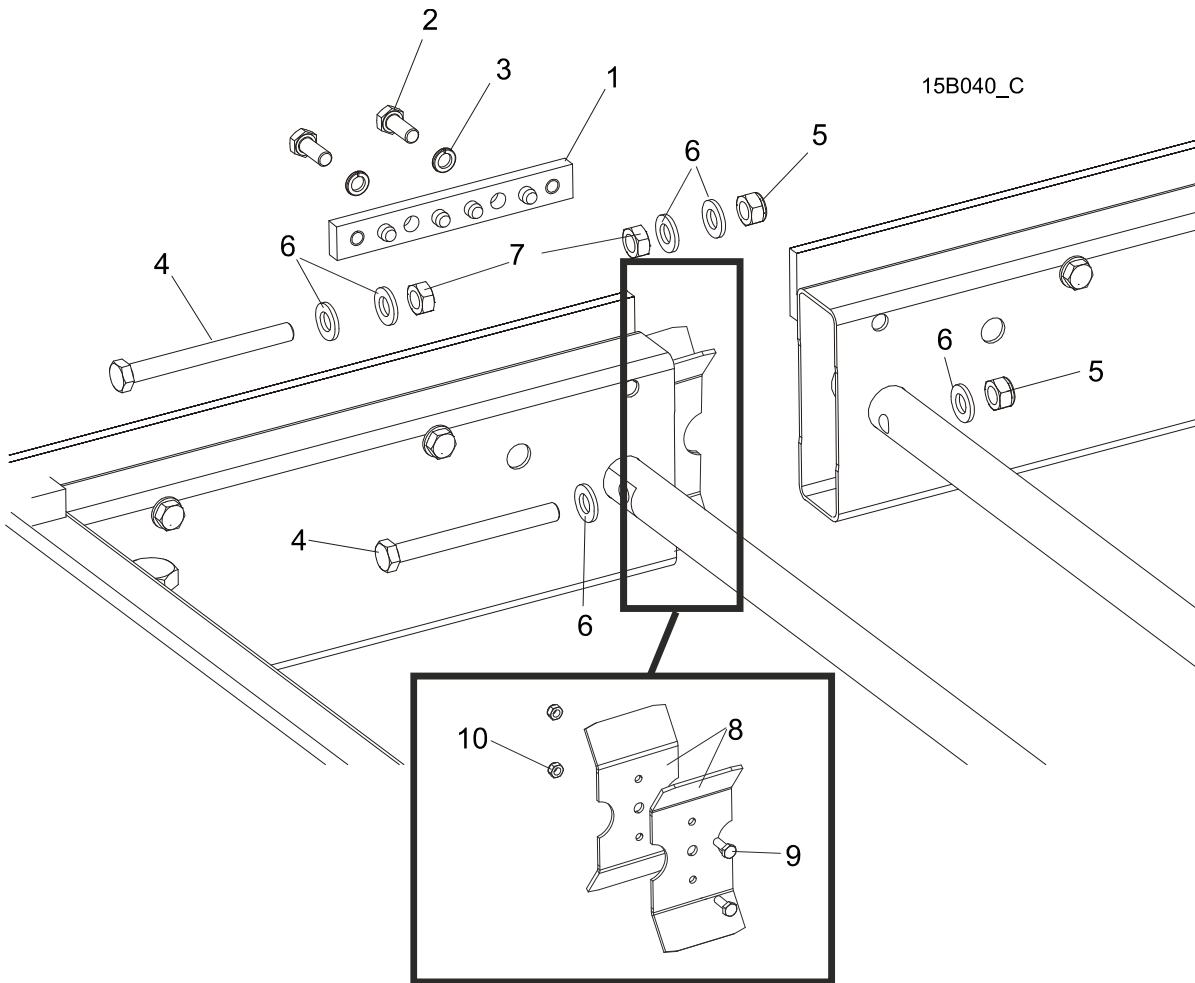

REF.	DESCRIPTION (◆ Indicates Parts Available In Assemblies Only)	PART #	QTY
1	PLATE, BED CONNECTION	086659-1	1
2	BOLT, M10X25 - 8.8 HEX HEAD FULL THREAD ZINC	F81003-11	2
3	WASHER, 10.2 FLAT	F81055-2	2
4	BOLT, M12 X 120 - 8.8 HEX HEAD ZINC	F81004-38	2
5	NUT, M12-8-B HEX NYLON ZINC LOCK	F81034-2	2
6	WASHER, 13 FLAT ZINC	F81056-1	6
7	NUT, M12-8-B HEX ZINC	F81034-1	2
	CONNECTOR, LT15 BED SECTION	506288 ¹	2
8	PLATE, LT15 BED SECTION CONNECTOR	506287-1	1
9	BOLT, M6 x 16 8.8 HEX HEAD FULL THREAD ZINC	F81001-15	2
10	NUT, M6-8-B HEX NYLON ZINC LOCK	F81031-2	2

¹ 2 pieces for each bed section

2.3 Stationary Leg Kit

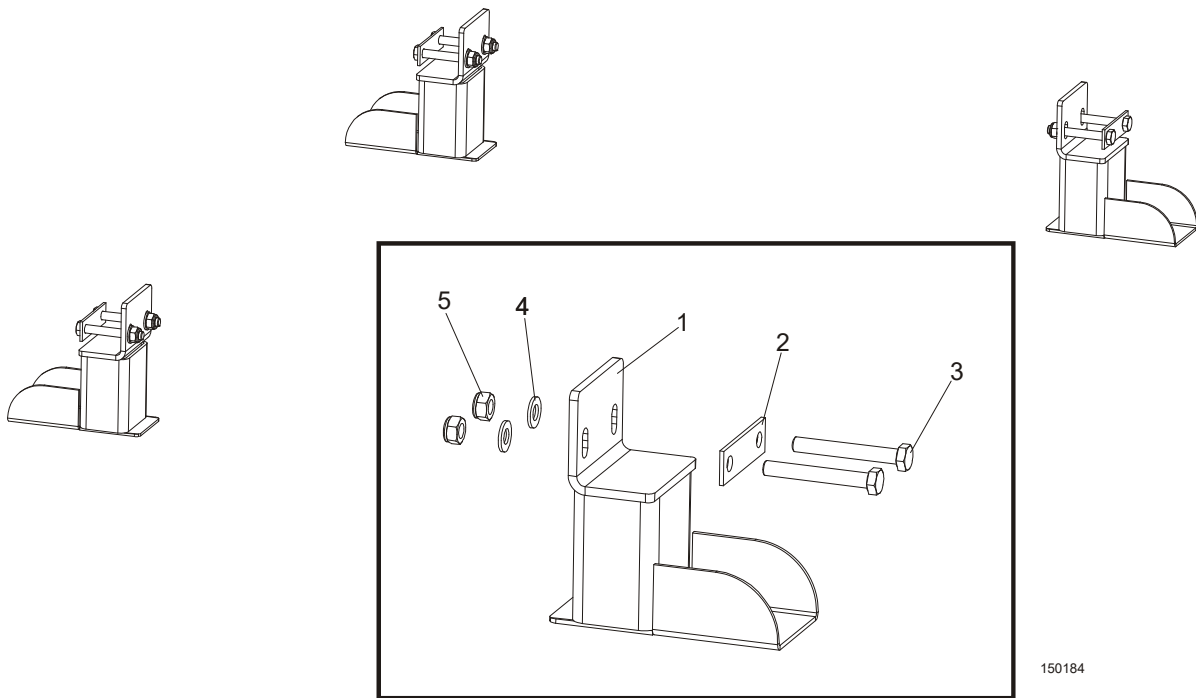

REF.	DESCRIPTION (◆ Indicates Parts Available In Assemblies Only)	PART #	QTY
	STATIONARY LEG KIT FOR 1950 MM BED SECTION	100069	1
1	Leg, LT15 Stationary Bed	100064-1	4
2	Washer, LT15 Bed Leg	085994-1	4
3	Bolt, M10x75-8.8 Hex Head Zinc	F81003-15	8
4	Washer, 10.5 Flat Zinc	F81055-1	8
5	Nut, M10-8-B Hex Nylon Zinc Lock	F81033-1	8
	STATIONARY LEG KIT FOR 2700 MM BED SECTION	100070	1
1	Leg, LT15 Stationary Bed	100064-1	6
2	Washer, LT15 Bed Leg	085994-1	6
3	Bolt, M10x75-8.8 Hex Head Zinc	F81003-15	12
4	Washer, 10.5 Flat Zinc	F81055-1	12
5	Nut, M10-8-B Hex Nylon Zinc Lock	F81033-1	12

2.4 Outrigger Leg Kit

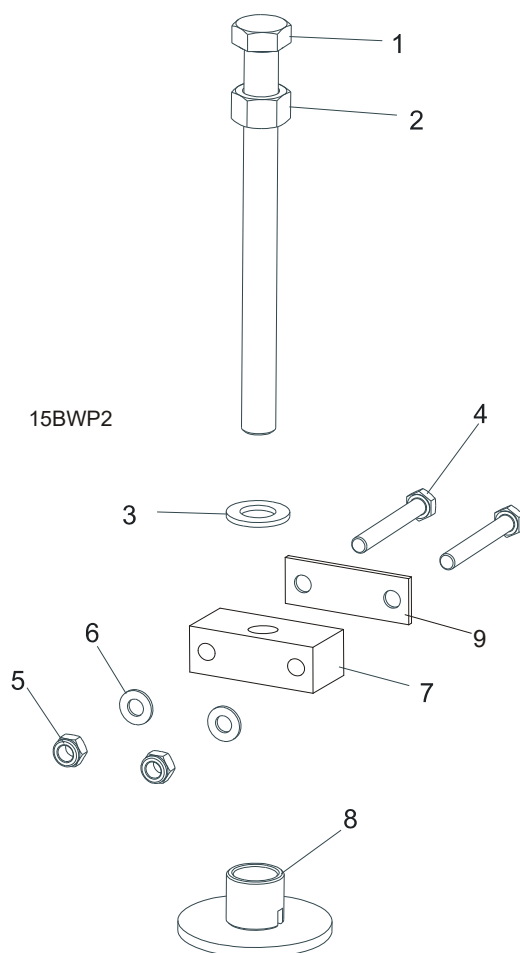

REF.	DESCRIPTION (◆ Indicates Parts Available In Assemblies Only)	PART #	QTY	
	OUTRIGGER LEG KIT FOR 1950 MM BED SECTION (LT15S3)	095232 ¹	3	
	OUTRIGGER LEG KIT FOR 2700 MM BED SECTION (LT15M2)	095234 ²	2	
1	Bolt, M20x240-8.8 Hex Head Full Thread Zinc	F81007-1	1	
2	Nut, M20-8 Hex Zinc	F81037-1	1	
3	Washer, 21 Flat Zinc	F81059-2	1	
4	Bolt, M10x120-8.8 Hex Head Zinc	F81003-58	2	
5	Nut, M10-8-B Hex Nylon Zinc Lock	F81033-1	2	
6	Washer, 10.5 Flat Zinc	F81055-1	2	
7	Block, LT15 Leg Mount	095745-1	1	
8	Plate Weldment, LT15 Leg Foot Zinc-plated	087771-1	1	
9	Washer, LT15 Bed	085994-1	1	

¹ Four legs are mounted to each 1950-mm long bed section.

² Six legs are mounted to each 2700-mm long bed section.

2.5 Log Clamp Assembly

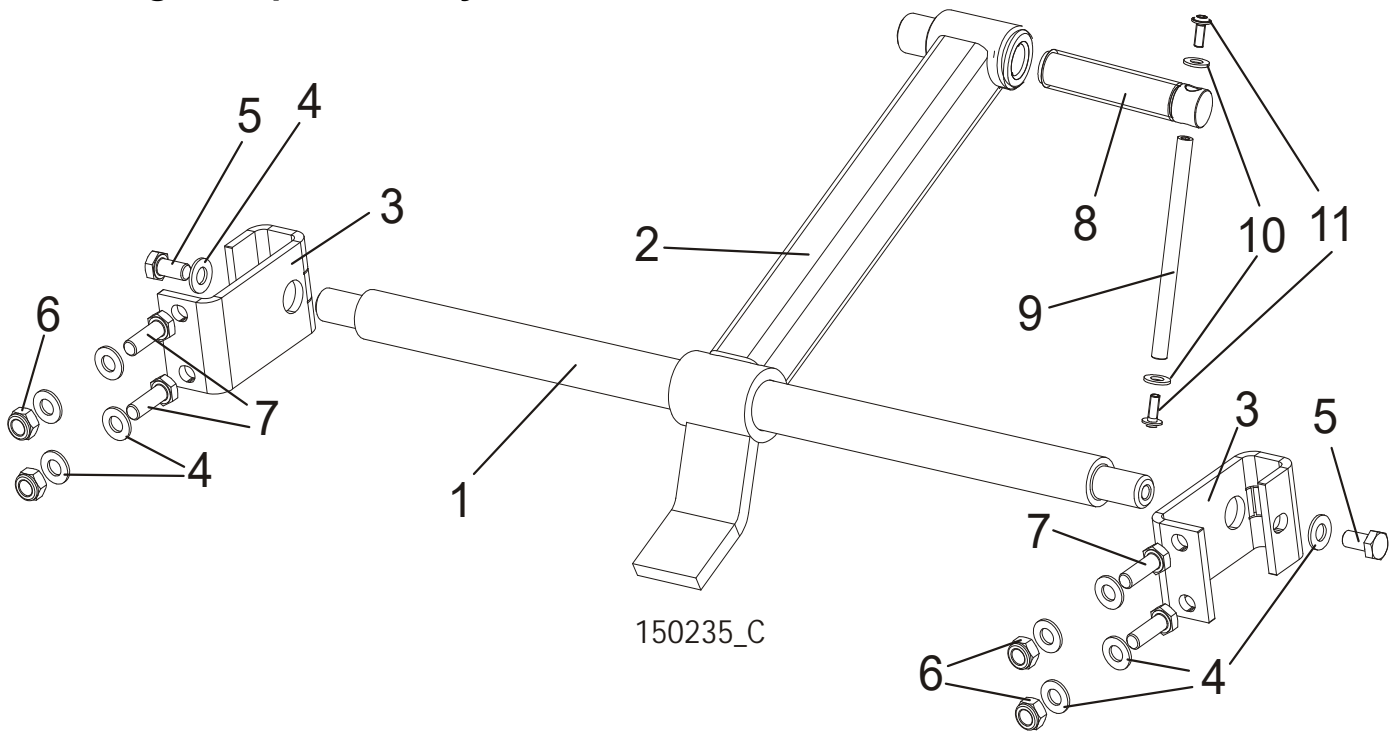

REF.	DESCRIPTION (◆ Indicates Parts Available In Assemblies Only)	PART #	QTY
	LOG CLAMP ASSEMBLY, LT10/15 COMPLETE	507565	2
1	ROD, CLAMP ZINC-PLATED MAIN	500343-1	1
2	ARM, CLAMP ZINC-PLATED	507566-1	1
3	BRACKET, LOG CLAMP MOUNT ZINC	506535-1	2
4	WASHER, 10.5 FLAT ZINC	F81055-1	10
5	BOLT, M10x20-5.8 HEX HEAD FULL THREAD ZINC	F81003-1	2
6	NUT, M10-8-B NYLON HEX ZINC LOCK	F81033-1	4
7	BOLT, M10X30-5.8 HEX HEAD FULL THREAD ZINC	F81003-2	4
	BOLT, CLAMP - COMPLETE	507563	1
8	BOLT, CLAMP	507463	1
	ROD, COMPLETE	511924	1
9	ROD, ZINC-PLATED	511923-1	1
10	WASHER, 8.4 FLAT ZINC	F81054-1	2
11	BOLT, M6x16 BN 11252 "BOSSARD"	F81001-24	2

2.6 Auxiliary Bed Rail Assembly

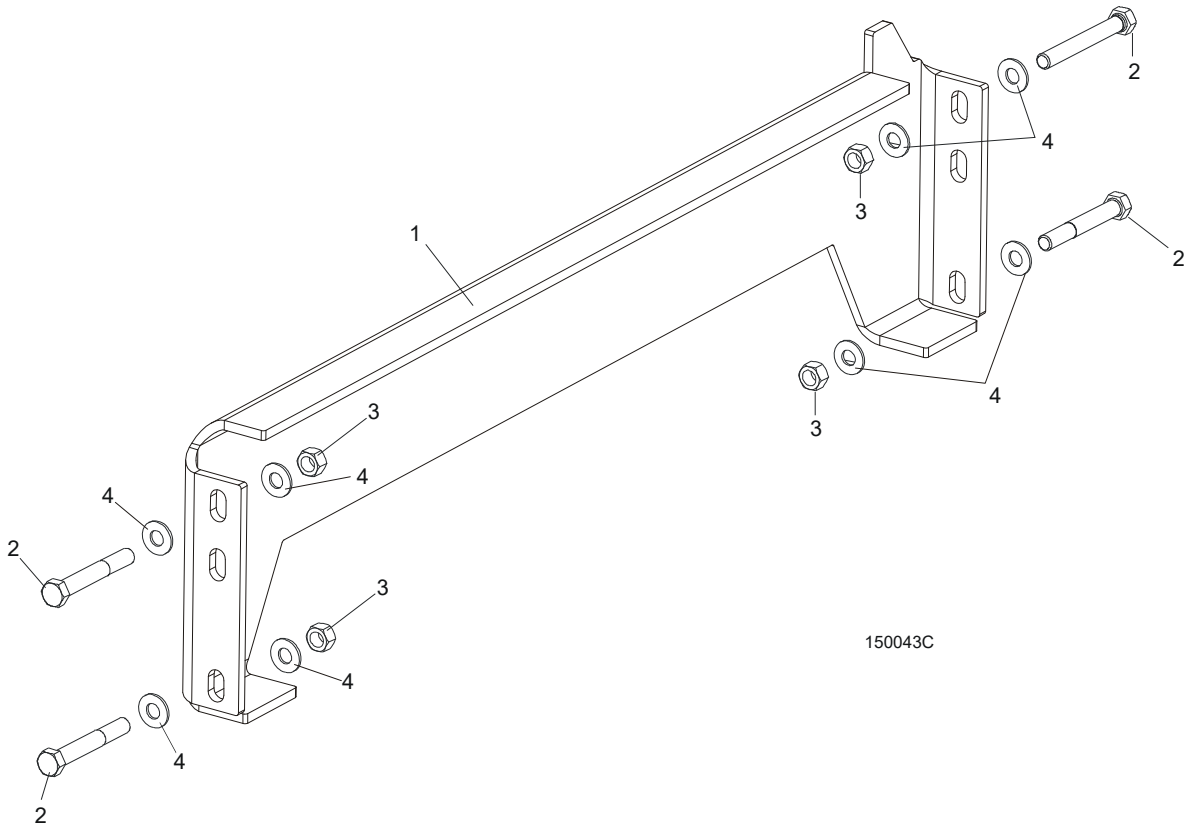

REF.	DESCRIPTION (◆ Indicates Parts Available In Assemblies Only)	PART #	QTY	
1	RAIL WELDMENT, LT15 AUXILIARY BED	095490-1	1	◆
2	BOLT, M10X75-8.8 HEX HEAD ZINC	F81003-15	4	
3	NUT, M10-8-B HEX NYLON ZINC LOCK	F81033-1	4	
4	WASHER, 10.5 ZINC FLAT	F81055-1	8	

2.7 Log Wedge, Loading Ramps, & Cant Hook (Optional)

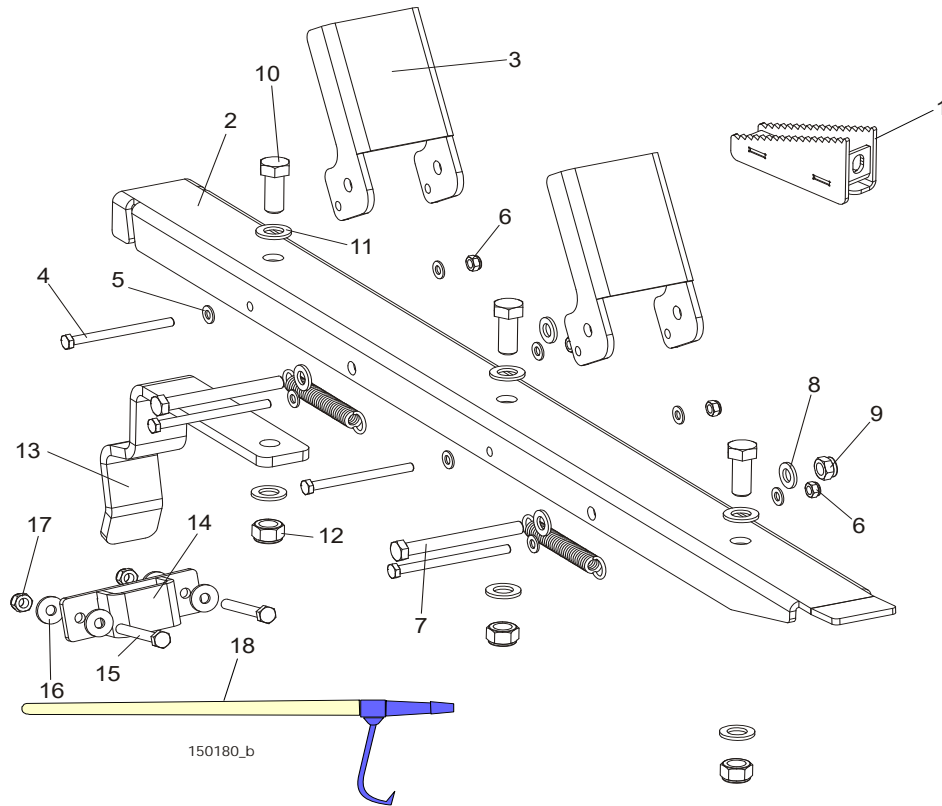

REF.	DESCRIPTION (◆ Indicates Parts Available In Assemblies Only)	PART #	QTY
	ACCESSORIES, LT15 SAWMILLS	085997	1
1	Wedge Weldment, Log Taper (included in 015811 kit)	510720-1	1
	Wedge Weldment, Log Taper (for bed rail with optional stainless steel cover)	515360-1	1
	Ramp, Log Loading - Complete	097977	2
	Ramp Assembly	097483	1
2	Plate, Log Loading Ramp Zinc-plated	097481-1	1
3	Bracket, Log Loading Ramp Stop Zinc-plated	097482-1	2
4	Bolt M8x100-8.8 Hex Head Zinc	F81002-23	4
5	Washer, 8.4 Flat Zinc	F81054-1	8
6	Nut, M8-8-B Hex Nylon Zinc Lock	F81032-2	4
7	Bolt, M12x115-8.8 Hex Head Zinc	F81004-33	2
8	Washer, 13 Flat Zinc	F81056-1	2
9	Nut, M12-8 Hex Nylon Zinc Lock	F81034-2	2
10	Bolt, M16x40-8.8 Hex Head Full Thread Zinc	F81006-13	2
11	Washer, 17 Flat Zinc	F81058-1	4
12	Nut, M16-8 Hex Nylon Zinc Lock	F81036-2	2
13	Bracket, LT15 Ramp Zinc	097976-1	1
	Bracket, LT15 Ramp - Complete	507518	1
14	Bracket Weldment, Ramp	507517-1	1
15	Bolt, M10x75-8.8 Hex Head Zinc	F81003-15	2
16	Washer, 10.5 Special Flat Zinc	F81055-6	4
17	Nut, M10-8-B Hex Nylon Zinc Lock	F81033-1	2
18	Cant Hook (included in 015811 kit)	CH	1

2.8 Bed Extension

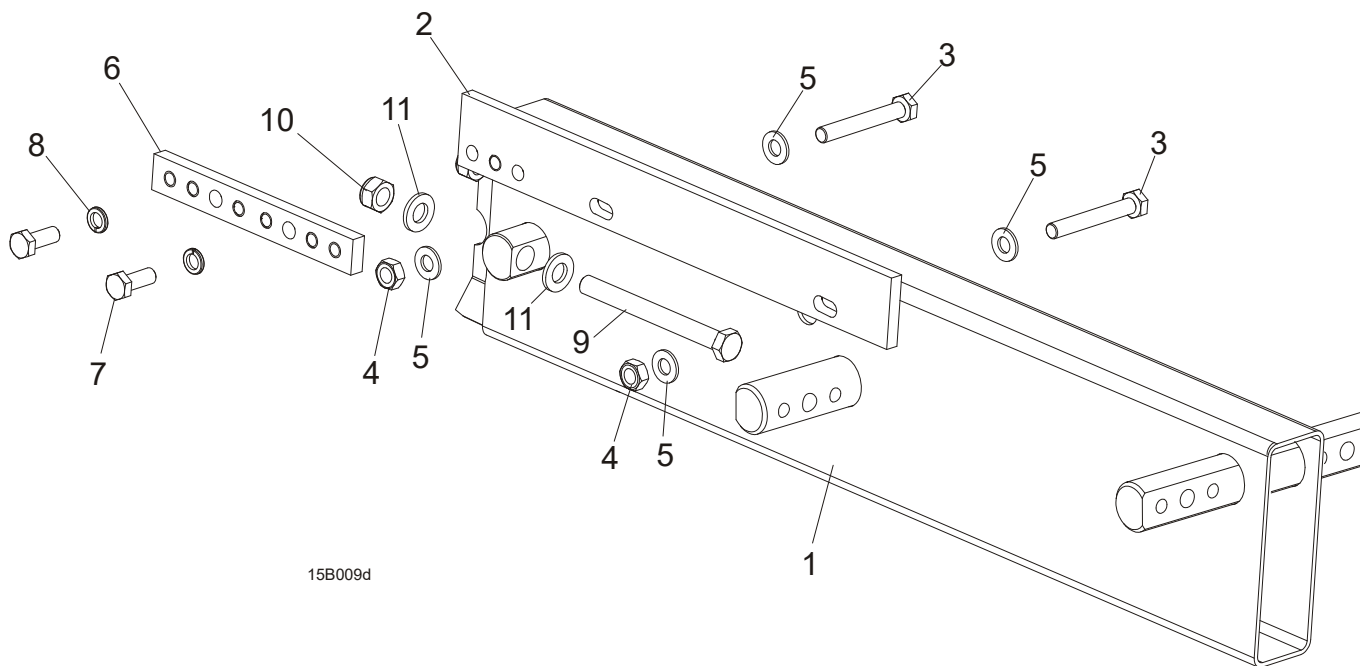

15B009d

REF.	DESCRIPTION (◆ Indicates Parts Available In Assemblies Only)	PART #	QTY
	EXTENSION, BED FRONT COMPLETE	500845	1
	EXTENSION, BED REAR COMPLETE	500843	1
1	Tube, LT15 GP Bed Extension	500844-1	1
2	Rail, Bed Extension Track Zinc-plated	094250-1	1
3	Bolt, M10 x 75-8.8 Hex Head Zinc	F81003-15	2
4	Nut, M10-8-B Hex Nylon Zinc Lock	F81033-1	2
5	Washer, 10.5 Flat Zinc	F81055-1	4
6	Splice, Track Rail Pinned	086659-1	1
7	Bolt, M10x30-8.8 Hex Head Full Thread Zinc	F81003-2	2
8	Washer, 10.2 Split Lock Zinc	F81055-2	2
9	Bolt, M12 x 120-8.8 Hex Head Zinc	F81004-38	2
10	Nut, M12-8 Hex Nylon Zinc Lock	F81034-2	2
11	Washer, 13 Flat Zinc	F81056-1	4

2.9 "M" Type Frame Bed Section

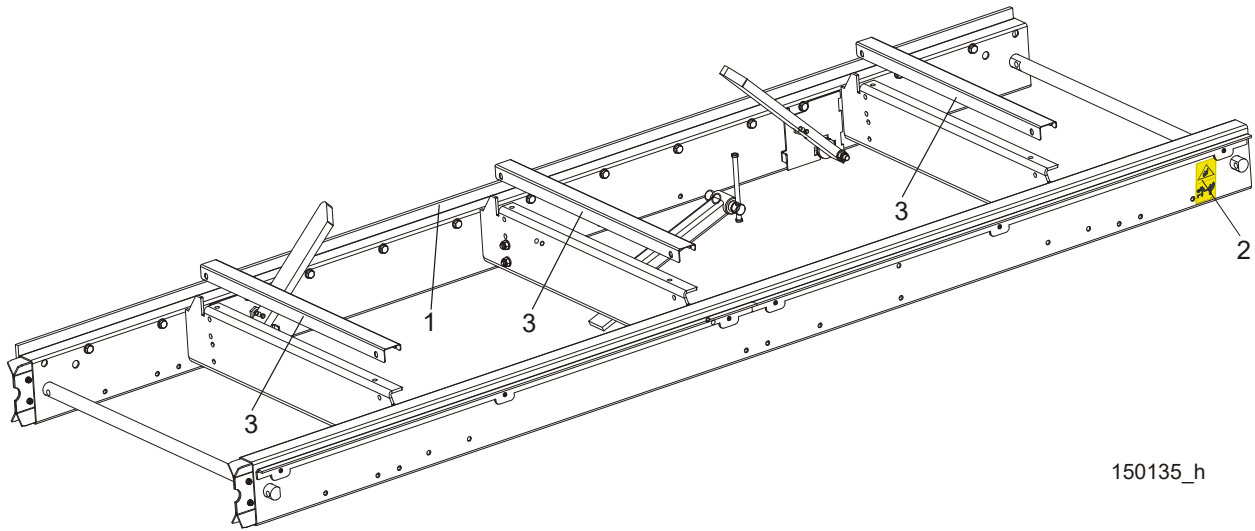

REF.	DESCRIPTION (◆ Indicates Parts Available In Assemblies Only)	PART #	QTY
	LT15 BED SECTION ASSEMBLY - LONG	094697	
1	Bar, LT15 2700 Track Zinc-plated	094696-1	1
2	DECAL, KEEP AWAY DANGER, PICTOGRAM	099221	1
3	COVER, BED RAIL LT10/15	509300 ¹	3

¹ Option

2.10 "S" Type Frame Bed Section

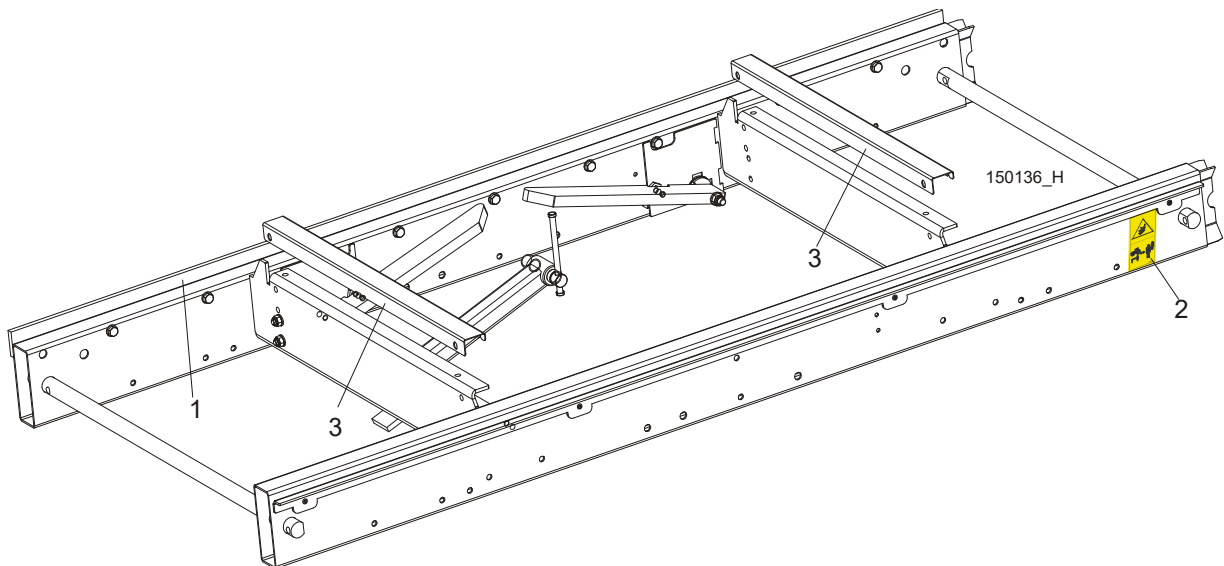

REF.	DESCRIPTION (◆ Indicates Parts Available In Assemblies Only)	PART #	QTY
	LT15 BED SECTION ASSEMBLY - SHORT	094514	
1	Bar, LT15 1950 Track Zinc-plated	094427-1	1
2	DECAL, KEEP AWAY DANGER, PICTOGRAM	099221	1
3	COVER, LT10/LT15 BED RAIL	509300 ¹	2



FRAME PARTS

"S" Type Frame Bed Section

¹ Option

2.11 Additional Bed Frame Section with Stationary Legs

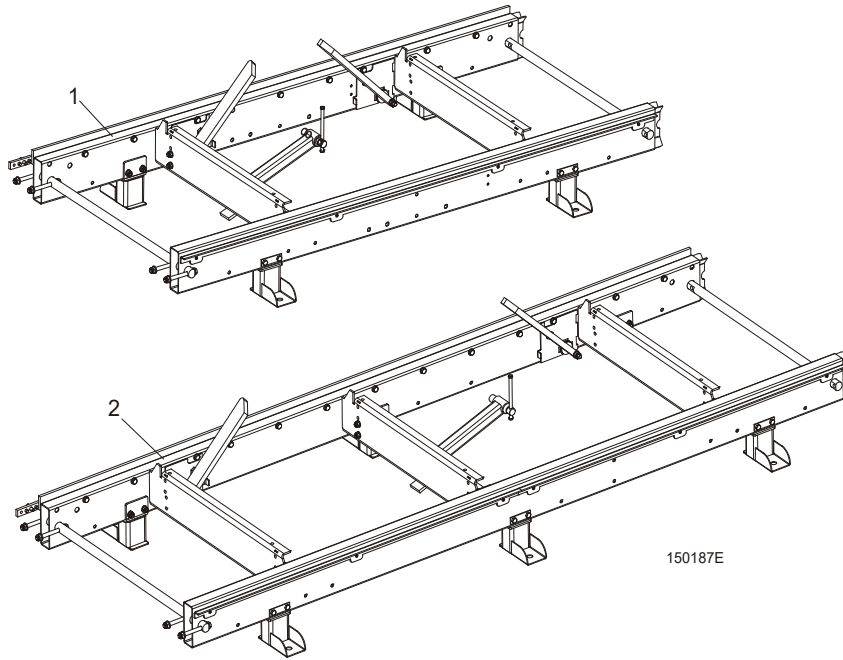

REF.	DESCRIPTION (◆ Indicates Parts Available In Assemblies Only)	PART #	QTY
1	BED SECTION, LT15 1950 W/STATIONARY LEGS	100341-S	1
2	BED SECTION, LT15 2700 W/STATIONARY LEGS	100342-S	1

2.12 Additional Bed Frame Section with Outrigger Legs

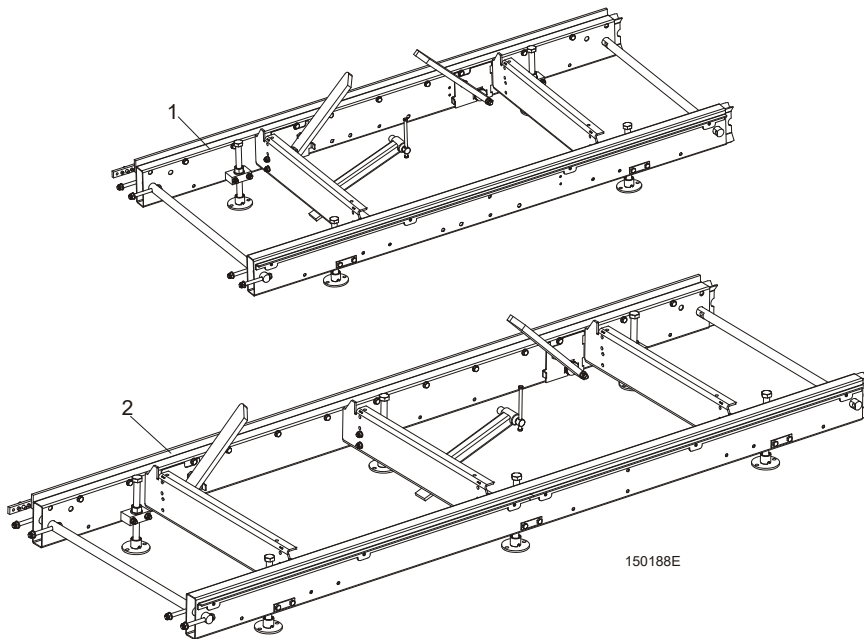

REF.	DESCRIPTION (◆ Indicates Parts Available In Assemblies Only)	PART #	QTY
1	BED SECTION, LT15 1950 W/OUTRIGGER LEGS	095082-S	1
2	BED SECTION, LT15 2700 W/OUTRIGGER LEGS	095083-S	1

SECTION 3 LEG ASSEMBLIES

3.1 "S" Frame Legs

526815_001-B
 526815_MANUAL

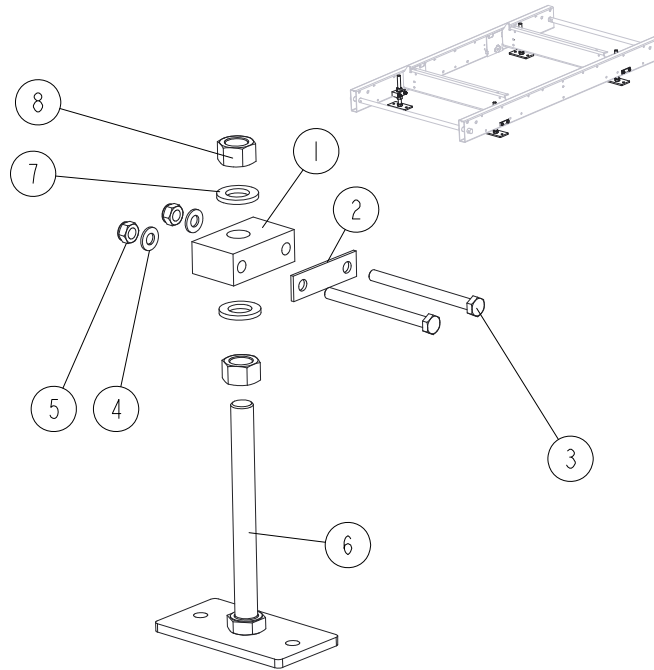

REF.	DESCRIPTION (* Indicates Parts Available in Assemblies Only)	PART NO.	QTY
-	LEG KIT, LT15WIDE - FRAME 1950 ADJUSTABLE	526815	1
1	BLOCK, LT15 LEG MOUNT	529838-1	4
2	WASHER, LT15 BED LEG	085994-1	4
3	BOLT, M10X120 8.8 HEX HEAD ZINC	F81003-58	8
4	WASHER, 10.5 FLAT ZINC	F81055-1	8
5	NUT, M10-8-B HEX NYLON ZINC LOCK	F81033-1	8
6	LEG WELDMENT, LT15W BED ZINC-PLATED	526820-1	4
7	WASHER, 21 FLAT ZINC	F81059-2	4
8	NUT, M20-8 HEX ZINC	F81037-1	4

3.2 "M" Frame Legs

526816_001_B
 526816_MANUAL

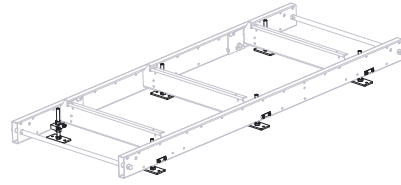
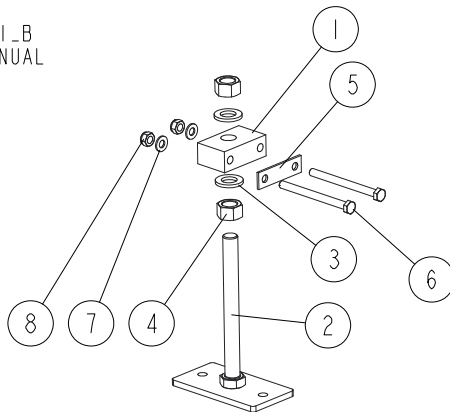

REF.	DESCRIPTION (* Indicates Parts Available in Assemblies Only)	PART NO.	QTY	
-	LEG KIT, LT15WIDE-FRAME 2700 ADJUSTABLE	526816	1	
1	BLOCK, LT15 LEG MOUNT	529838-1	6	
2	LEG WELDMENT, LT15W BED ZINC-PLATED	526820-1	6	
3	WASHER, 21 FLAT ZINC	F81059-2	6	
4	NUT, M20-8 HEX ZINC	F81037-1	6	
5	WASHER, LT15 BED LEG	085994-1	6	
6	BOLT, M10X120 8.8 HEX HEAD ZINC	F81003-58	12	
7	WASHER, 10.5 FLAT ZINC	F81055-1	12	
8	NUT, M10-8-B HEX NYLON ZINC LOCK	F81033-1	12	

SECTION 4 BLADE GUIDE ROLLERS & ARM

4.1 Blade Guide Assembly, Idle Side

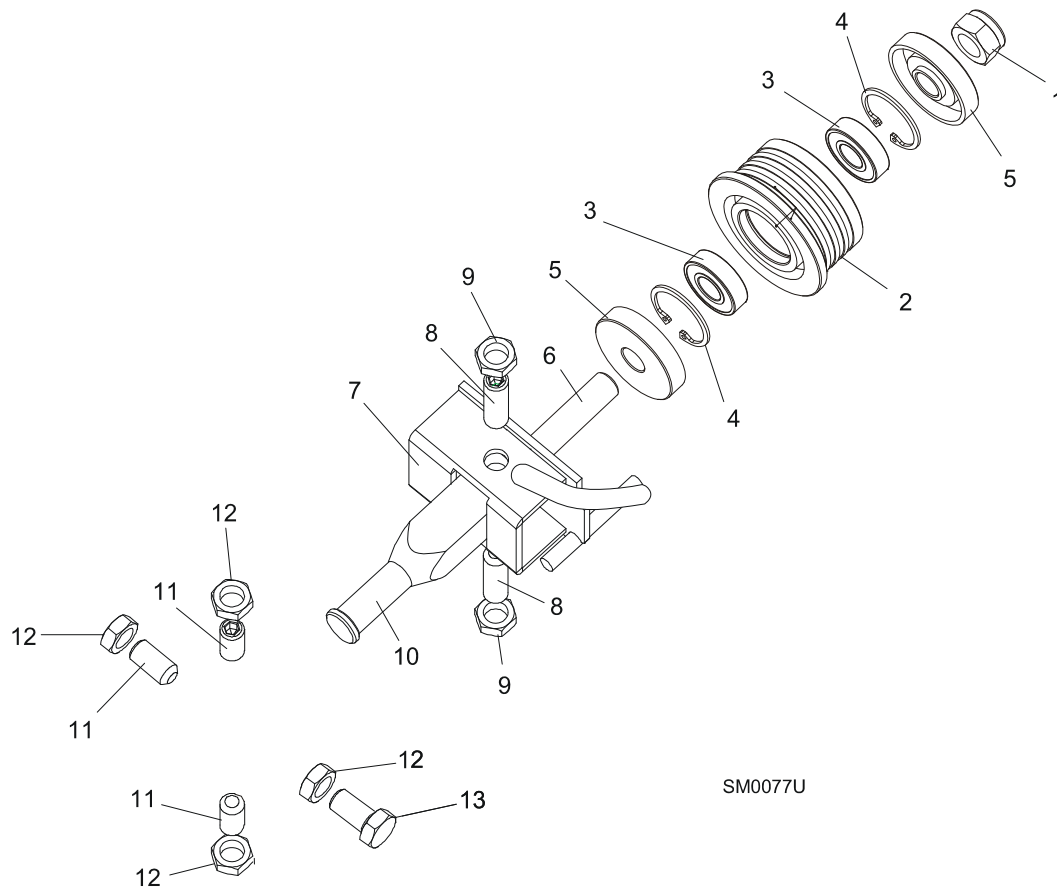

REF.	DESCRIPTION (◆ Indicates Parts Available In Assemblies Only)	PART #	QTY	
	BLADE GUIDE ASSEMBLY, IDLE SIDE	094683	1	
	Roller, Blade Guide Complete Standard	087887	1	
1	Nut, M12-8 Hex Nylon Zinc Lock	F81034-2	1	
2	Roller, Blade Guide Narrow	087889	1	◆
3	Bearing, 6001 2RSR FAG	087893	2	
4	Ring, W28 Inside Retaining	F81090-9	1	
5	Washer, Zinc-plated Spacer	087891-1	2	
6	Shaft, Blade Guide Roller Zinc-plated	087763-1	1	
7	Bracket Weldment, Idle Side Blade Guide	094681-1	1	
8	Screw, M10x1x40 DIN 913 A2-70 Set Stainless Steel	F81015-2	2	
9	Nut, M10x1-04-ST-A2 ISO 8675 Thin	F81033-10	2	
10	Shaft, Zinc-plated Blade Guide Mount	503588-1	1	
11	SCREW, M10X1X25 DIN 913 SET STAINLESS STEEL	F81015-4	4	
12	NUT, M10x1-04-ST-A2 ISO 8675 THIN	F81033-10	4	

4.2 Blade Guide Assembly, Drive Side

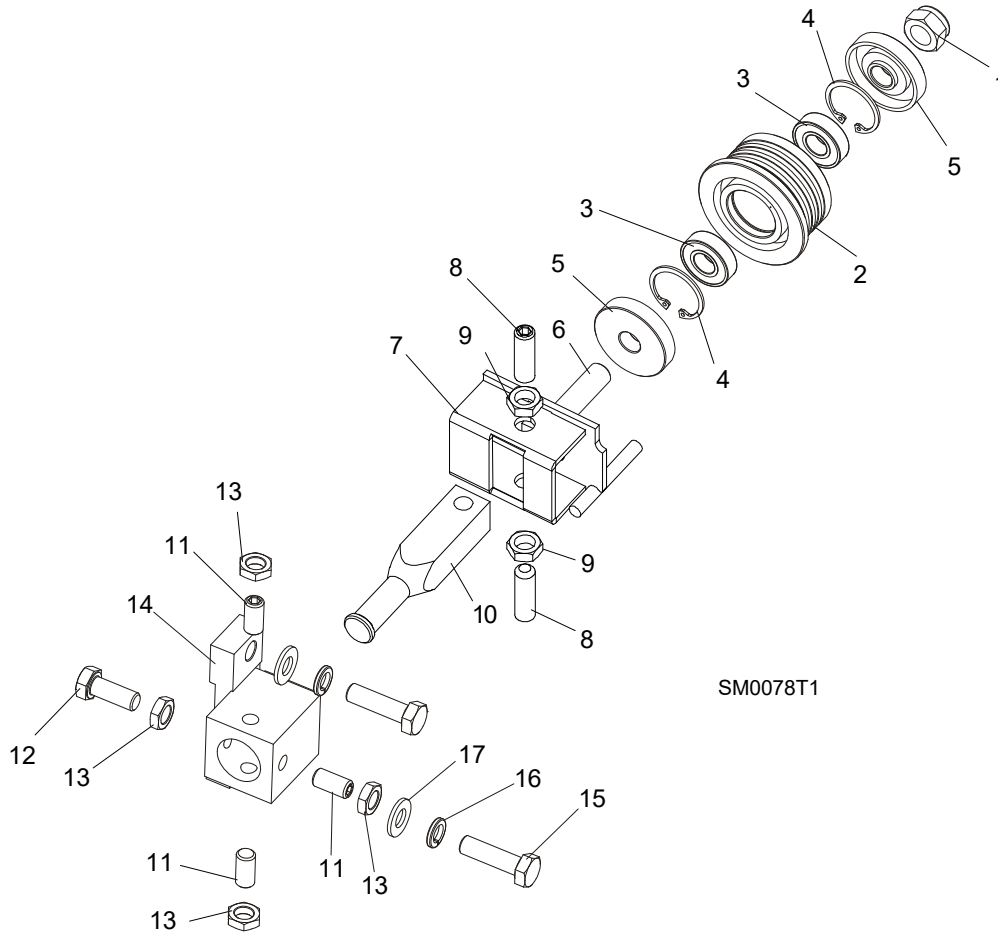

SM0078T1

REF.	DESCRIPTION (◆ Indicates Parts Available In Assemblies Only)	PART #	QTY
	BLADE GUIDE ASSEMBLY, DRIVE SIDE	094682	1
	Roller, Blade Guide Complete Standard	087887	1
1	Nut, M12-8 Hex Nylon Zinc Lock	F81034-2	1
2	Roller, Blade Guide Narrow	087889	1
3	Bearing, 6001 2RSR FAG	087893	2
4	Ring, W28 Inside Retaining	F81090-9	1
5	Washer, Zinc-plated Spacer	087891-1	2
6	Shaft, Blade Guide Roller Zinc-plated	087763-1	1
7	Bracket Weldment, Blade Guide Painted	094679-1	1
	Screw Kit, Blade Guide Adjustment w/Nuts (for two blade guide assemblies)	K09942	1
8	Screw, M10x1x40 DIN 913 A2-70 Set Stainless Steel	F81015-2	2
9	Nut, M10x1-04-ST-A2 ISO 8675 Thin	F81033-10	2
10	Shaft, Zinc-plated Blade Guide Mount	503588-1	1
11	SCREW, M10X1X25 DIN 913 SET STAINLESS STEEL	F81015-4	3
12	BOLT, M10X1X25 DIN 933 STAINLESS STEEL	F81003-28	1
13	NUT, M10x1-04-ST-A2 ISO 8675 THIN	F81033-10	4

4**Blade Guide Rollers & Arm***Blade Guide Assembly, Drive Side*

14	TUBE, BLADE GUIDE MOUNT	087744	1	
15	BOLT, M10X35-8.8 HEX HEAD FULL THREAD ZINC	F81003-17	2	
16	WASHER, 10.2 SPLIT LOCK ZINC	F81055-2	2	
17	WASHER, 10.5 FLAT ZINC	F81055-1	2	

4.3 Blade Guide Roller Guard

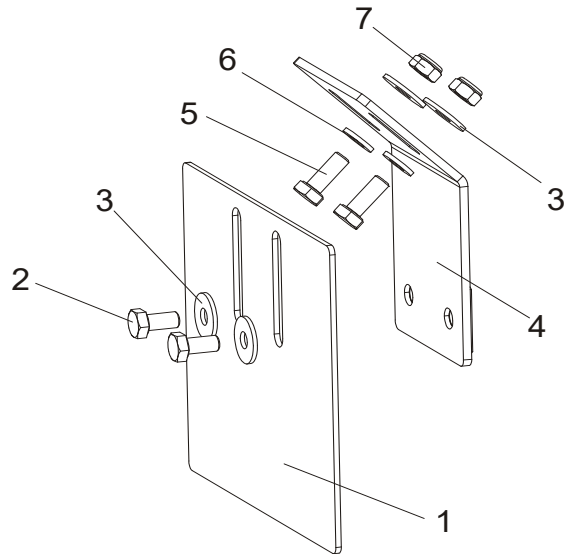

REF.	DESCRIPTION (◆ Indicates Parts Available In Assemblies Only)	PART #	QTY
1	GUARD, BLADE GUIDE ROLLER	092379-1	1
2	BOLT, M6X12-8.8 HEX HEAD FULL THREAD ZINC	F81001-7	2
3	WASHER, 6.5 SPECIAL FLAT ZINC	F81053-11	4
4	BRACKET, ROLLER GUARD MOUNT	092378-1	1
5	BOLT, M6X16 8.8 HEX HEAD FULL THREAD ZINC	F81001-15	2
6	WASHER, 6.4 FLAT ZINC	F81053-1	2
7	NUT, M6-8-B HEX NYLON ZINC LOCK	F81031-2	2

4.4 Blade Guide Arm w/Lever

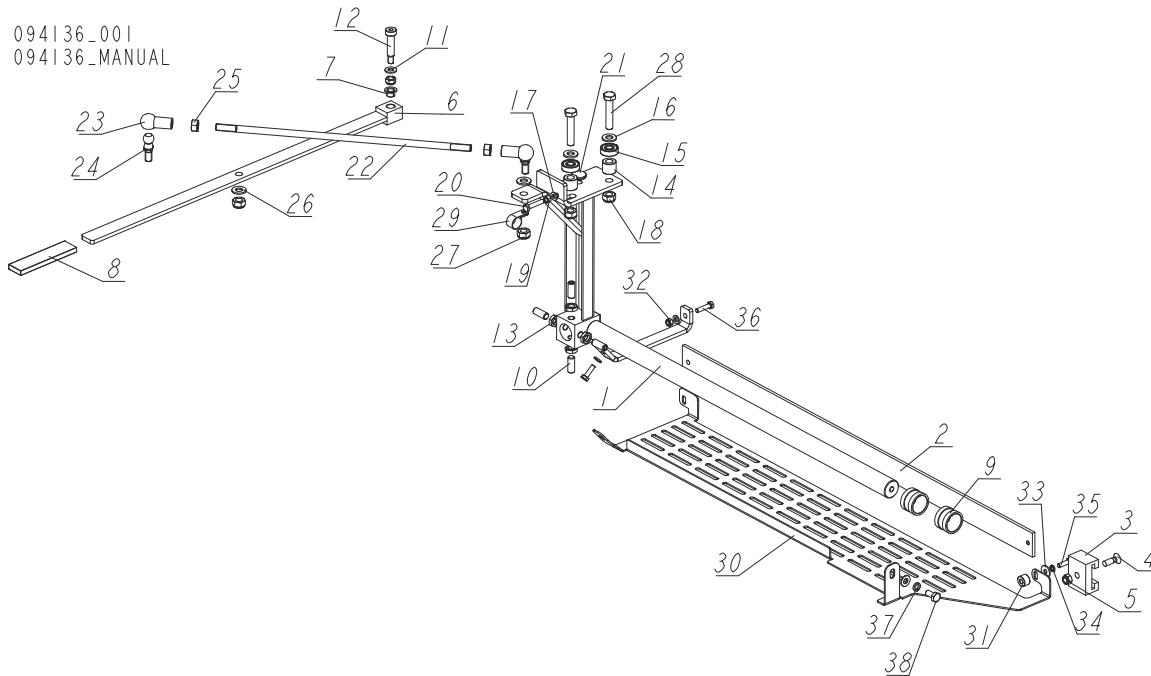

REF.	DESCRIPTION (◆ Indicates Parts Available In Assemblies Only)	PART #	QTY
-	BLADE GUIDE ARM W/LEVER - COMPLETE	094136	1
1	ARM WELDMENT, BLADE GUIDE	094138-1	1
2	BAR, BLADE GUARD	088306	1
3	GUIDE, BLADE GUARD	088305	1
4	SCREW, M8X25 CROSS RECESSED COUNTERSUNK HEAD ZINC	F81002-51	1
5	NUT, M8-8-B HEX NYLON ZINC LOCK	F81032-2	2
-	LEVER ASSEMBLY, BLADE GUIDE ARM ADJUSTMENT	093812	1
6	LEVER, BLADE GUIDE ARM ADJUSTMENT	093813-1	1
7	BEARING, TUF1 10.090 (CX)	099074	2
8	SLEEVE, VINYL GUARD	086875	1
9	BUSHING, BLADE GUIDE	086684	2
10	SCREW, M10X1X25 DIN 913 STAINLESS STEEL SET	F81015-4	4
11	WASHER, 8.4 FLAT ZINC	F81054-1	2
12	BOLT, 10/M8X35 12.9 ISO7379 SHOULDER	F81003-63	1
13	NUT, M10X1-04-ST-A2E ISO8675 THIN	F81033-10	4
14	BUSHING, 11/20-17 ZINC-PLATED	094255-1	2
15	BEARING, 6000.2RSR	087471	2
16	WASHER, 10.5 FLAT ZINC	F81055-1	4
17	WASHER, 6.4 FLAT ZINC	F81053-1	5
18	NUT, M10-8-B HEX NYLON ZINC LOCK	F81033-1	2
19	NUT, M6 8 HEX ZINC	F81031-1	1
20	BOLT, M6X30-5.6 HEX HEAD FULL THREAD	F81001-13	1
21	BUSHING, BLADE GUIDE ARM	095936	1

REF.	DESCRIPTION (◆ Indicates Parts Available In Assemblies Only)	PART #	QTY	
-	STUD BOLT ASSEMBLY, ARM LEVER CONNECTION	094204	1	
22	BOLT, ZINC-PLATED STUD	094203-1	1	
23	SEAT, BALL	093824-1	2	
24	STUD, 16/SW-13 DIN71803-C BN486 BALL	093823	2	
25	NUT, M10 8 HEX ZINC	F81033-3	2	
26	WASHER, 10.5 FLAT ZINC	F81055-1	2	
27	NUT, M10-8-B HEX NYLON ZINC LOCK	F81033-1	2	
28	BOLT, M10X50-8.8 HEX HEAD FULL THREAD ZINC	F81003-4	2	
29	CLAMP, 5/8 EMT COATED	010748	1	
30	GUARD, BOTTOM	525592-1	1	
31	BUSHING, 6.5/16-10.5	525463-1	1	
32	NUT, M6-8-B HEX NYLON ZINC LOCK	F81031-2	2	
33	WASHER, 6.5 SPECIAL FLAT ZINC	F81053-11	1	
34	WASHER, Z 6.1 SPLIT LOCK ZINC	F81053-3	1	
35	BOLT, M6X20 8.8 HEX HEAD FULL THREAD ZINC	F81001-2	2	
36	BOLT, M6X25 5.8 HEX HEAD FULL THREAD ZINC	F81001-3	1	
37	WASHER, 8.2 SPLIT LOCK ZINC	F81054-4	1	
38	BOLT, M8X16-8.8-B HEX HEAD FULL THREAD ZINC	F81002-20	1	

SECTION 5 BLADE WHEELS & TENSIONER

5.1 Blade Wheel Assembly, Drive Side

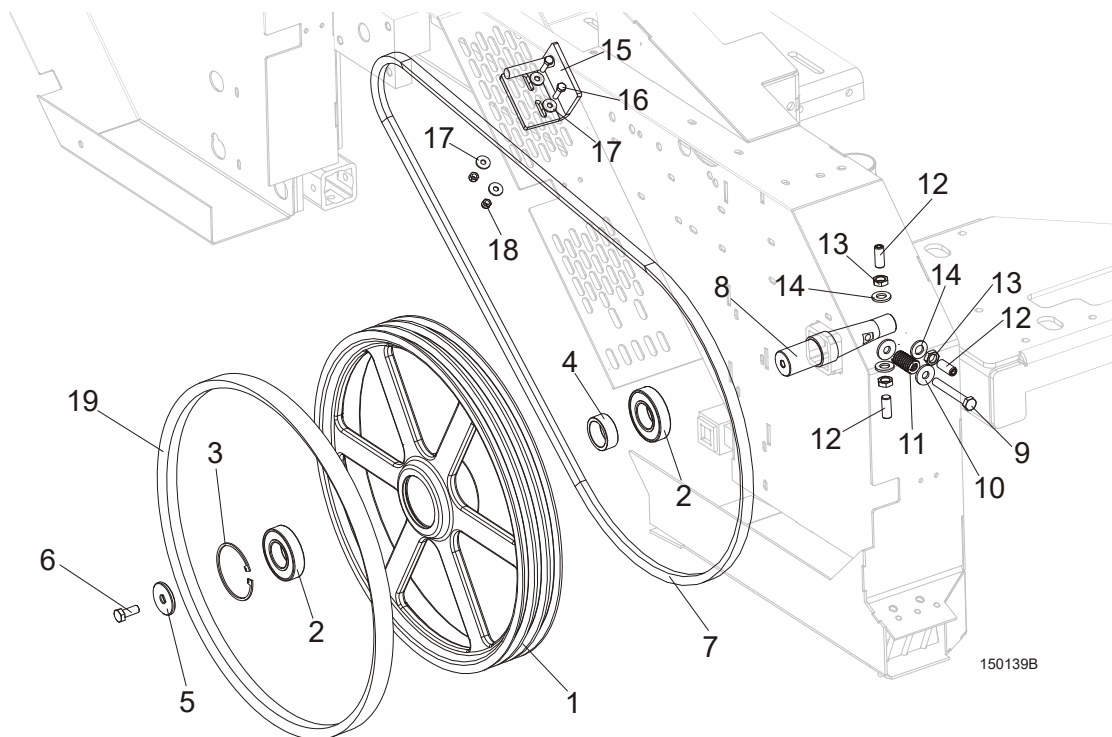

REF.	DESCRIPTION (◆ Indicates Parts Available In Assemblies Only)	PART #	QTY
	WHEEL ASSEMBLY, DRIVE SIDE BLADE	093849	1
1	WHEEL, DRIVE SIDE BLADE	014727	1
2	BEARING, 6207 2RS 35X72X17 FAG	014811	2
3	RING, 72MM OD N5002-281 RETAINING	F04254-30	1
4	SPACER, DRIVE BEARING	093851	1
5	WASHER, LT15 DRIVE SIDE BLADE WHEEL	086286	1
6	BOLT, M10X25-8.8 HEX HEAD FULL THREAD ZINC	F81003-11	1
7	BELT, G15/D10	097448	1
8	SHAFT, LT15 DRIVE SIDE BLADE WHEEL	093850	1
9	BOLT, M10X75-8.8 HEX HEAD ZINC	F81003-15	1
10	WASHER, 10.5 FLAT SPECIAL ZINC-PLATED	F81055-6	2
11	SPRING, 3/4 O.D.X 1 1/2 DIE	034430	1
12	SCREW, M12X1,25X30 DIN913 STAINLESS STEEL SET	F81016-1	3
13	NUT, M12X1.25 DIN439 STAINLESS STEEL THIN	F81034-9	3
14	WASHER, 13 FLAT ZINC	F81056-1	3
15	BRACKET, DRIVE BELT LOWER	092636-1	1
16	BOLT, M6X20-8.8 HEX HEAD FULL THREAD ZINC	F81001-2	2
17	WASHER, 6.5 SPECIAL FLAT ZINC	F81053-11	4
18	NUT, M6-8-B HEX NYLON LOCK ZINC	F81031-2	2
19	V-BELT, B57	P04185-2	1

5.2 Blade Wheel Assembly, Idle Side

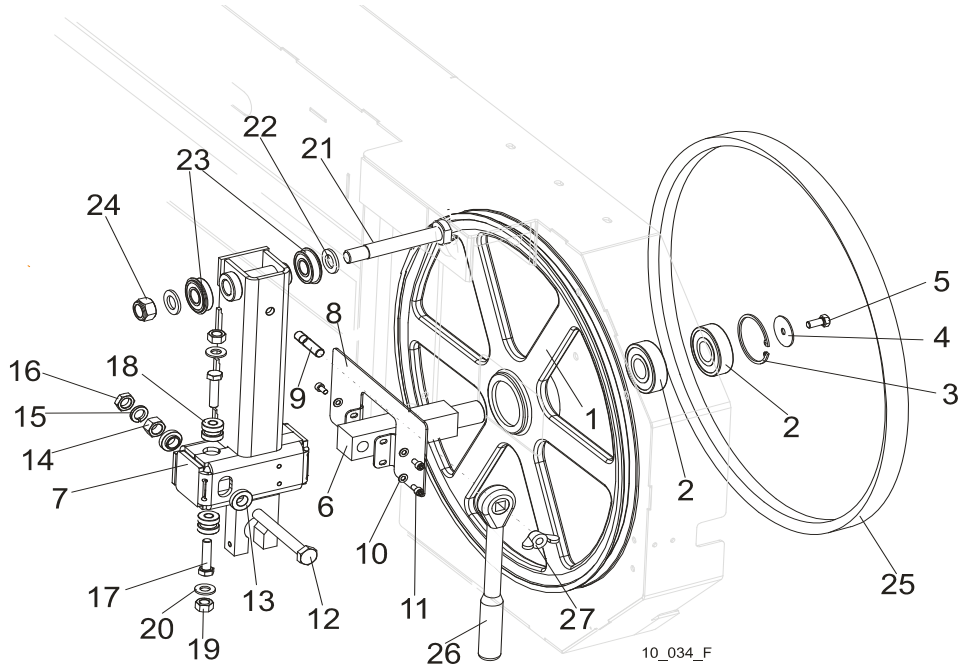

REF,	DESCRIPTION (◆ Indicates Parts Available In Assemblies Only)	PART #	QTY
	WHEEL ASSEMBLY, IDLE SIDE BLADE	A08218	1
1	WHEEL ASSEMBLY, 18.62" IDLE SIDE BLADE	P08125	1
2	BEARING, 6305 2RS NSK IDLE SIDE WHEEL	P08066	2
3	RING, 2 7/16" INSIDE RETAINING	F04254-21	1
	HOUSING, LT10 & LT15 IDLER SHAFT, COMPLETE	100180	1
4	WASHER, IDLE SIDE WHEEL RETAINING	093854-1	1
5	BOLT, M8X25-8.8-B HEX HEAD FULL THREAD ZINC	F81002-5	1
6	SHAFT, IDLE SIDE BLADE WHEEL (METRIC)	096045	1
	ARM, IDLE SIDE WHEEL ROCKER - COMPLETE	508145	1
7	ARM WELDMENT, IDLE SIDE BLADE WHEEL ROCKER	508144-1	1
8	COVER, IDLER SHAFT HOUSING - COMPLETE	508128-1	1
9	STUDBOLT, M10X35-8.8	F81003-9	1
10	WASHER, 5.3 FLAT ZINC	F81052-1	3
11	SCREW, M5x10 DIN912 A2-70 HEX SOCKET HEAD	F81000-23	3
12	BOLT, M12X1,25X100-8.8 HEX HEAD FULL THREAD ZINC	F81004-41	1
13	WASHER, FLANGED ZINC-PLATED	086769-1	2
14	NUT, M12X1.25 -8 HEX ZINC	F81034-8	1
15	WASHER, 12.2 SPLIT LOCK ZINC	F81056-2	1
16	NUT, M12x1.25 DIN439 THIN STAINLESS STEEL	F81034-5	1
17	BOLT, M10 X 40-8.8 HEX HEAD FULL THREAD ZINC	F81003-16	2
18	BUSHING, M10 IDLER SHAFT HOUSING	086987	2
19	NUT, M10-8-B HEX HEAD ZINC	F81033-3	2
20	WASHER, 10.5 FLAT ZINC	F81055-1	2
21	PIN, IDLER ARM MOUNT	086404	1
22	WASHER, 17 FLAT ZINC	F81058-1	2
23	BEARING, 6203-2RS NR NSK W/SNAP RING	086395	2

24	NUT, M16-8 HEX NYLON ZINC LOCK	F81036-2	1	
25	V-BELT, B57	P04185-2	1	
26	WRENCH, LT20 BLADE TENSION	091620	1	
27	NUT, M10 WING ZINC	F81033-8	1	

5.3 Blade Tensioner Assembly

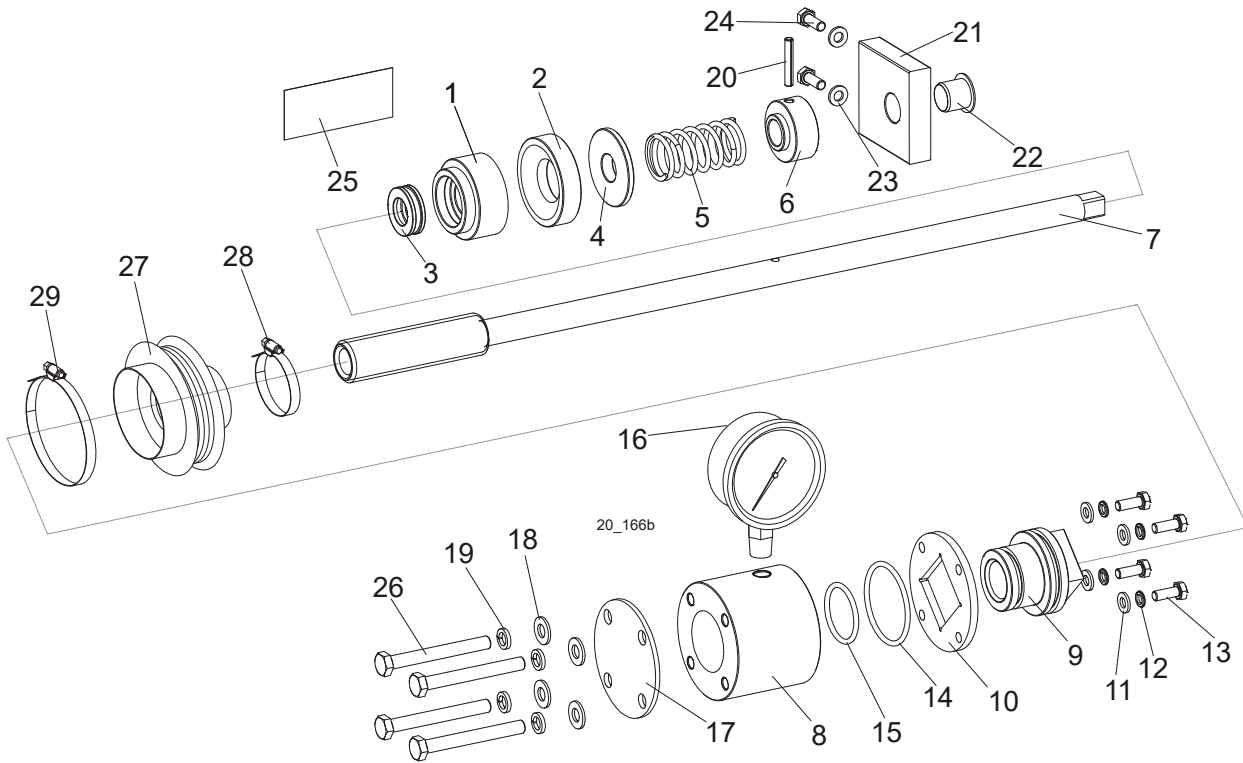

REF.	DESCRIPTION (◆ Indicates Parts Available In Assemblies Only)	PART #	QTY	
	COMPLETE BLADE TENSIONER	510640	1	
1	HOUSING, BALL THRUST BEARING	510635	1	
2	SOCKET, BEARING HOUSING	510634-1	1	
3	BEARING, 51103. BALL THRUST	086675	1	
4	WASHER	510633-1	1	
5	SPRING, n3mm	088992	1	
6	BUSHING, BLADE TENSIONER SCREW	510636-1	1	
7	SCREW, BLADE TENSIONER ZINC-PLATED	510650-1	1	
	CYLINDER ASSEMBLY	510641	1	
8	CYLINDER	510657-1	1	
9	PISTON	510638	1	
10	PLATE, CYLINDER	510490-1	1	
11	WASHER, 6.4 FLAT ZINC	F81053-1	4	
12	WASHER, Z 6.1 SPLIT LOCK ZINC	F81053-3	4	
13	BOLT, M6x16-8.8 HEX HEAD FULL THREAD ZINC	F81001-15	4	
14	O-RING, 46.2x3	510646	1	
15	O-RING, 32.2x3	510647	1	

16	GAUGE, 3000psi/200 bar OIL PRESSURE	505176	1	
17	PLATE, CYLINDER COVER	510642-1	1	
18	WASHER, 8.4 FLAT ZINC	F81054-1	4	
19	WASHER, 8.2 SPLIT LOCK ZINC	F81054-4	4	
20	PIN, 5x30 ROLL ZINC	F81044-21	1	
21	BLOCK, TENSIONER HANDLE MOUNT	096730	1	
22	BUSHING, GFM-1618-17	089589	1	
23	WASHER, 6.4 FLAT ZINC	F81053-1	2	
24	BOLT, M6x16-8.8 HEX HEAD FULL THREAD ZINC	F81001-15	2	
25	DECAL, PRESSURE VALUES	510643	1	
26	BOLT, M8x70-8.8 HEX HEAD ZINC	F81002-71	4	
27	BELLOWS, COMPLETE	515050	1	
28	BELLOWS	515051	1	
29	CLAMP, 40-60MM DIA.	F81095-4	1	
30	CLAMP, 70-80MM DIA.	F81095-5	1	
	OIL, HYDRAULIC - ALL SEASONS, ESSO UNIVIS HVI26	P12824	30 ml	

SECTION 6 SAW HEAD

6.1 Blade Housing Cover

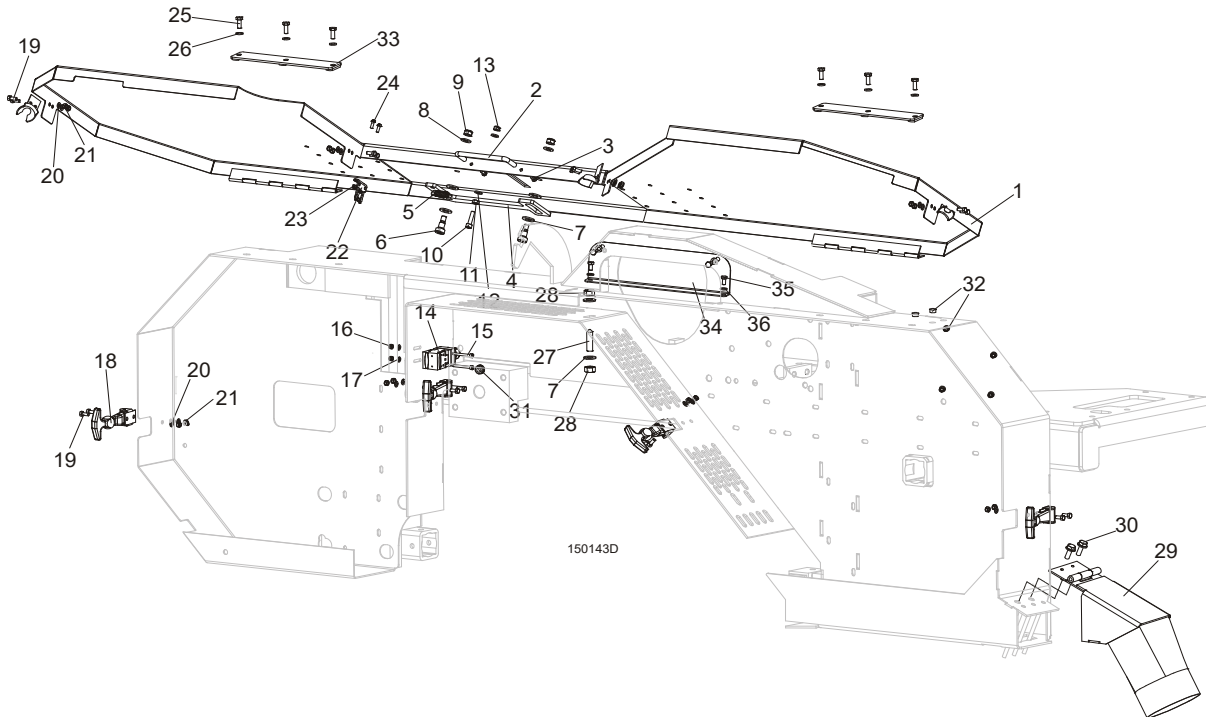

REF.	DESCRIPTION (◆ Indicates Parts Available In Assemblies Only)	PART #	QTY
	COVER, LT15 FRONT COMPLETE	098678	1
1	Cover Weldment, LT10/15/20 Blade Housing	096776-1	1
2	Handle w/Bolt	P08065	1
3	Screw, #8-32x3/8 Self-tapping	F05015-8	2
4	Pawl, Locking Painted	090643-1	1
5	Spring, 1.6x12x38 Extension	092208	1
6	Bolt, 10/M8x12-12.9 ISO-7379 Shoulder	F81003-62	2
7	Washer, 10.5 Flat Zinc	F81055-1	4
8	Washer, 8.4 Flat Zinc	F81054-1	2
9	Nut, M8-8-B Hex Nylon Zinc Lock	F81032-2	2
10	Screw, M6x25-8.8 Hex Socket Head Cap Zinc	F81001-41	1
11	Nut, M6-8 Hex Zinc	F81031-1	1
12	Washer, 6.4 Flat Zinc	F81053-1	2
13	Nut, M6-8-B Hex Nylon Zinc Lock	F81031-2	1
14	SWITCH, AZ17-11ZRK SAFETY	094232	1
15	SCREW, M4X35-8.8 HEX SOCKET HEAD CAP ZINC	F81011-34	2
16	NUT, M4-B HEX NYLON ZINC LOCK	F81029-1	2
17	WASHER, 4.3 FLAT ZINC	F81051-2	2
18	LATCH, FLEXIBLE DRAW	014829	4
19	BOLT, M5X12-5.8 HEX HEAD FULL THREAD ZINC	F81000-5	8

20	WASHER, 5.3 FLAT ZINC	F81052-1	8	
21	NUT, M5-8 DIN 985 ZINC-PLATED	F81030-2	8	
22	KEY, A217/170-B5 SAFETY SWITCH	094422	1	
23	NUT, M4-B HEX NYLON ZINC LOCK	F81029-1	2	
24	SCREW, M4X12-5.8-B CROSS RECESSED PAN HEAD ZINC	F81011-43	2	
25	BOLT, M6X16 8.8 HEX HEAD FULL THREAD ZINC	F81001-15	6	
26	WASHER, 6.4 FLAT ZINC	F81053-1	6	
27	SCREW, M10X40-45H HEX SOCKET SET CONE POINT ZINC	F81003-61	1	
28	NUT, M10-8-B HEX ZINC	F81033-3	2	
29	CHUTE, LT10/15/20 SAWDUST	100903-1	1	
30	BOLT, M8X16-8.8-B HEX HEAD FULL THREAD ZINC	F81002-20	2	
31	GROMMET, 22mm DIA. RUBBER	087400	1	
32	CAP, SR1086-9.5	096846	6	
33	PLATE, COVER MOUNT	086701-1	2	
34	COVER, SAW HEAD MOUNT	096788-1	1	
35	BOLT, M6X12-8.8 HEX HEAD FULL THREAD ZINC ZINC	F81001-7	4	
36	WASHER, 6.4 FLAT ZINC	F81053-1	4	

6.2 Water Lube Assembly

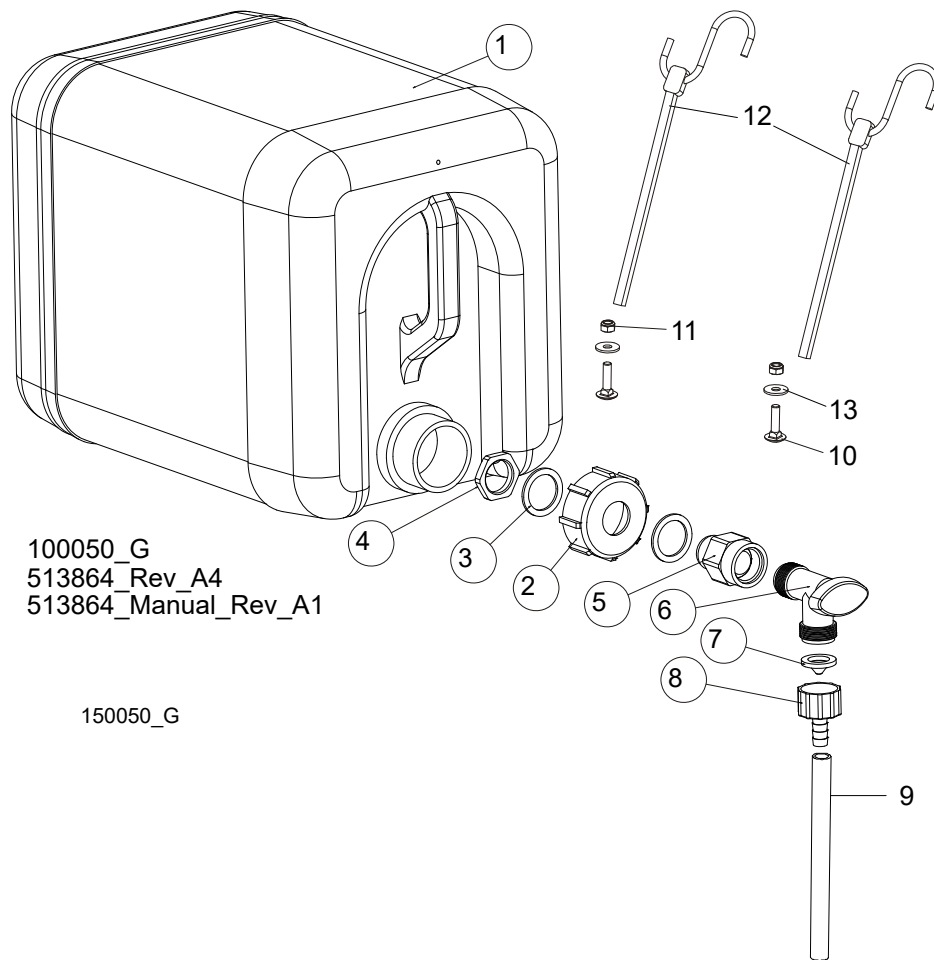

REF.	DESCRIPTION (◆ Indicates Parts Available In Assemblies Only)	PART #	QTY
	BOTTLE, WATER - COMPLETE	513864	1
	BOTTLE WITH NUT, WATER	513865¹	1
1	BOTTLE, WATER	513866	1
2	NUT, BOTTLE	513867	1
3	SEAL, RUBBER 35x26x2.	513869	2
4	NUT, P3/4 NPT GLAND	513868	1
5	FITTING, 3/4FPT X 3/4MPT REDUCER	014636	1
6	FITTING, WATER LUBE SHUTOFF VALVE	014100	1
7	FILTER, WATER LUBE	016086	1
8	FITTING, 5/8" NPT TO 3/8" HOSE BARB	014113	1
9	TUBE, 3/8" I.D. WATER LUBE	R01885	1.7 m
10	BOLT, M6X25-8.8 MUSHROOM HEAD SQUARE NECK ZINC	F81001-20	2
11	NUT, M6-8-B HEX NYLON ZINC LOCK	F81031-2	2
12	STRAP, 24" RUBBER W/HOOK	P11258	2
13	WASHER, 6.5 SPECIAL FLAT ZINC	F81053-11	2

¹ The service number 513865-S includes: 513865, 513869, 513868.

6.3 Blade Lube System (not available in EC version)

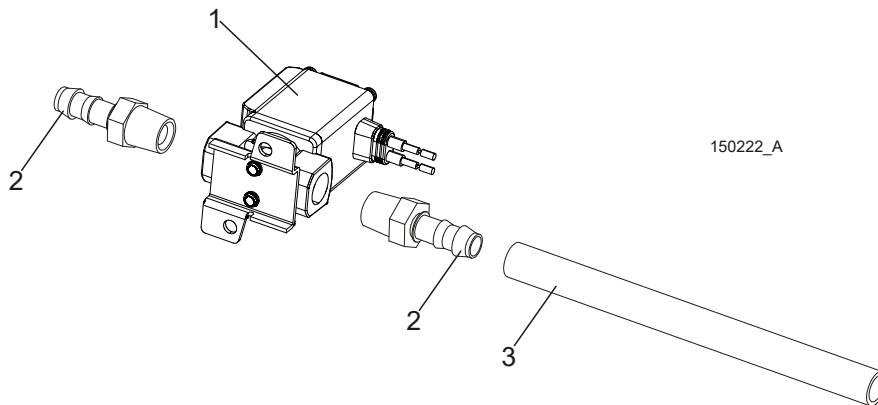

REF.	DESCRIPTION (◆ Indicates Parts Available In Assemblies Only)	PART #	QTY
	KIT, LT15DC BLADE LUBE SYSTEM	503471-S	1
1	SOLENOID, WATER LUBE	509113	1
2	FITTING, 3/8 BARB 1/4NPT MALE NYLON	P04682	2
3	TUBING, WATER LUBE	R01885	3.8m
	HOSE, WSN6	R80620-2	1m
	CABLE, 1 SQ MM BLUE	R80583-1	0,5m
	TERMINAL, KO 2.5/5 RING	F81064-1	2
	CONNECTOR, 16-14GA FI BUTT	F04875-1	2
	WASHER, 5.1 SPLIT LOCK ZINC	F81052-2	2
	SCREW, 10-32X1/2 HH MACHINE	F05004-60	2
	WASHER, 5.3 FLAT ZINC	F81052-1	2

6.4 LT15DC Saw Head Decals

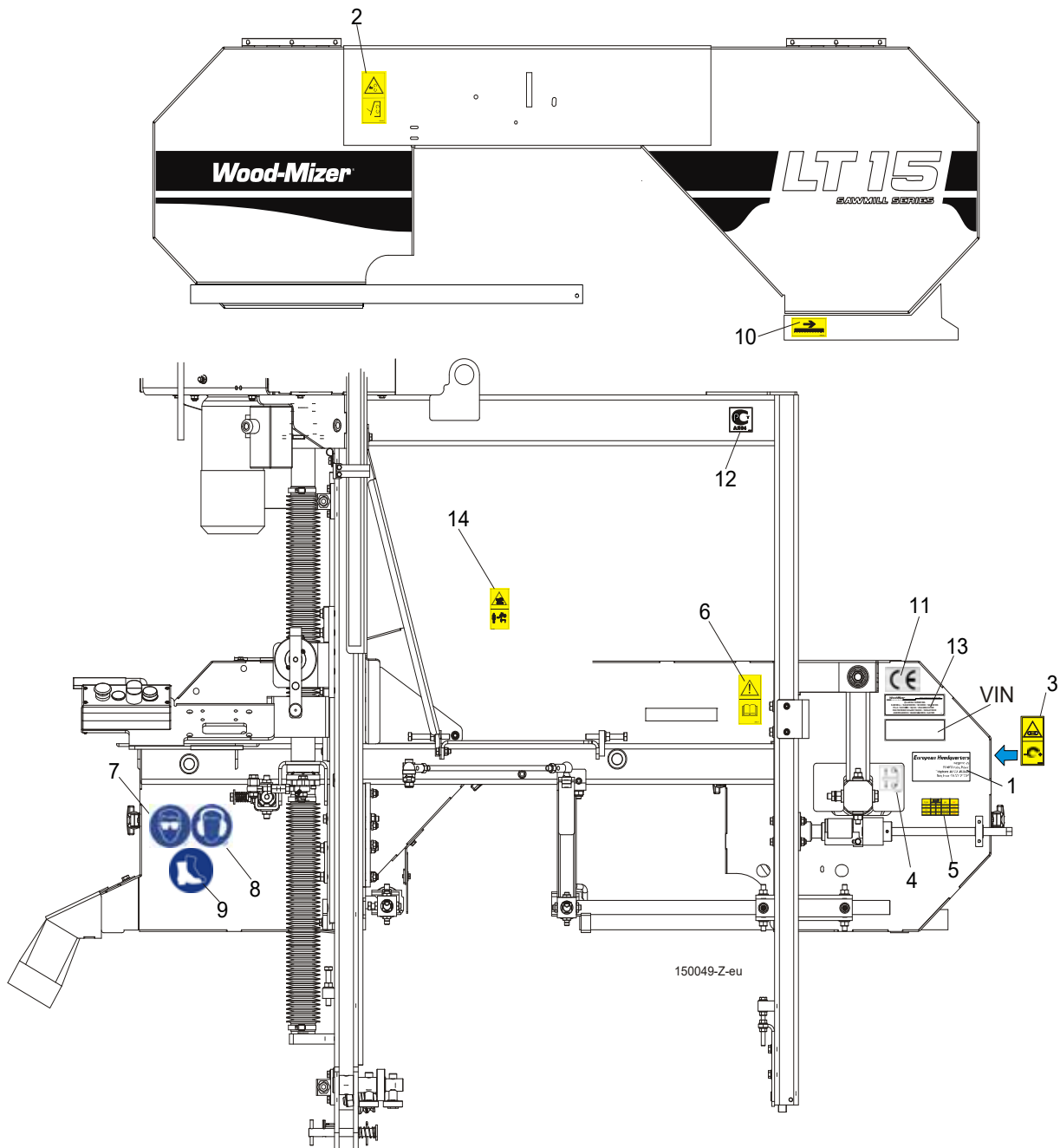

REF.	DESCRIPTION (◆ Indicates Parts Available In Assemblies Only)	PART #	QTY
	PICTOGRAPHIC DECAL KIT, LT15DC	099421	1
	DECAL, LT15 SERIES SAWMILL	092761	1
1	DECAL, EUROPEAN HEADQUARTERS ADDRESS	015841	1
2	DECAL, SAWMILL COVERS CAUTION	099220	1
3	DECAL, BLADE TENSION (PICTOGRAM)	099219	1
4	DECAL, BLADE ALIGNMENT	P11789	1
5	DECAL, BLADE TENSION INDICATOR ADJUSTMENT	510643	1

6	DECAL, READ OPERATOR'S MANUAL (PICTOGRAM)	096317	1	
7	DECAL, EYE PROTECTION WARNING (PICTOGRAM)	S12004G	1	
8	DECAL, EAR PROTECTION WARNING (PICTOGRAM)	S12005G	1	
9	DECAL, USE SAFETY BOOTS (PICTOGRAM)	501465	1	
10	DECAL, BLADE MOVEMENT DIRECTION (PICTOGRAM)	096321	1	
11	DECAL, CE CERTIFIED SAWMILL (SMALL)	P85070	1	
12	DECAL, RUSSIAN SAFETY CERTIFICATION	099401	1	
13	DECAL, INTERNATIONAL SAWMILL NAME	501466	1	
14	DECAL, KEEP AWAY - HOT PARTS	086099	1	

6.5 Control Box (Power Feed)

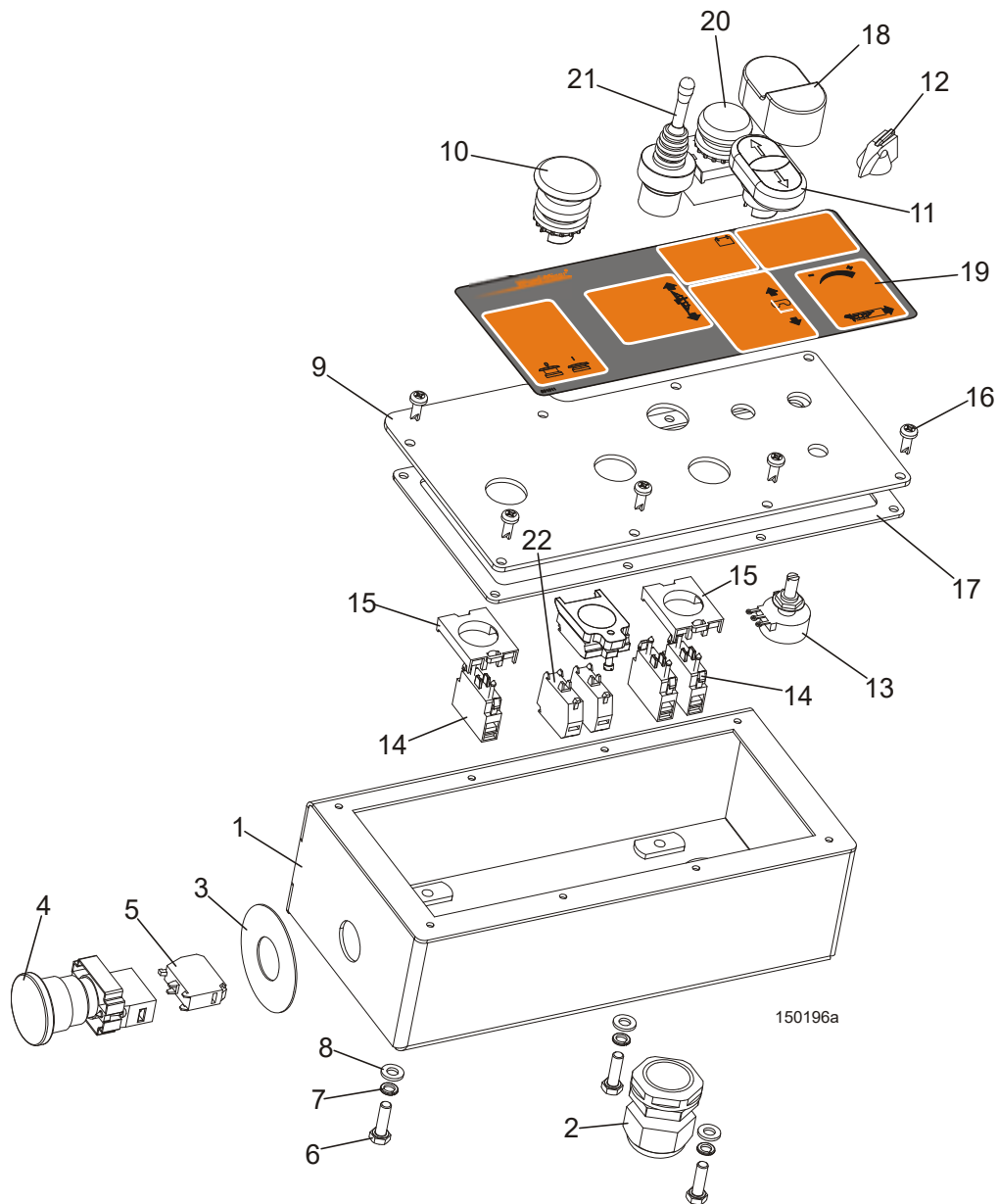

REF.	DESCRIPTION (◆ Indicates Parts Available In Assemblies Only)	PART #	QTY
	CONTROL BOX, LT15DC COMPLETE	501010	1
1	CONTROL BOX, LT15DC	501275-1	1
2	GLAND, Pg 21 CABLE	F81096-3	1
3	WASHER, EMERGENCY STOP SWITCH	086561	1
4	SWITCH, XB4 BS542 EMERGENCY STOP	086556	1
5	CONTACT, ZB2-BE102	086810	1
6	BOLT, M6x20-8.8 HEX HEAD FULL THREAD ZINC	F81001-2	3
7	WASHER, Z6.1 SPLIT LOCK ZINC	F81053-3	3
8	WASHER, 6.4 FLAT ZINC	F81053-1	3
	PANEL, LT15DC CONTROL BOX FRONT COMPLETE	501291	1

9	PANEL, LT15 CONTROL BOX FRONT	501277-1	1	
10	BUTTON, M22 MOMENTARY MUSHROOM GREEN	094328	1	
11	BUTTON, M22-DD-S-X7/X7	090917	1	
12	KNOB, SPEED CONTROL	P06257	1	
13	POTENTIOMETER, 1K	E20519	1	
14	ELEMENT, M22-K10 CONTACT	091362	3	
15	CONNECTOR, M22-A	100905	2	
16	BOLT, #10-24 x 1/2 PH PAN HD, TYPE 23	F05015-17	8	
17	GASKET, LT15 CONTROL BOX	501279	1	
18	DIAPHRAGM, M22-T-DD MOELLER	090462	1	
19	DECAL, LT15DC CONTROL BOX PANEL	501011	1	
20	LIGHT, M22 24V RED LED CONTROL	092719	1	
21	JOYSTICK, XD4PA22	087815	1	
22	CONTACT, ZBE 101	087817	2	

6.6 Electric Box, LT15 DC

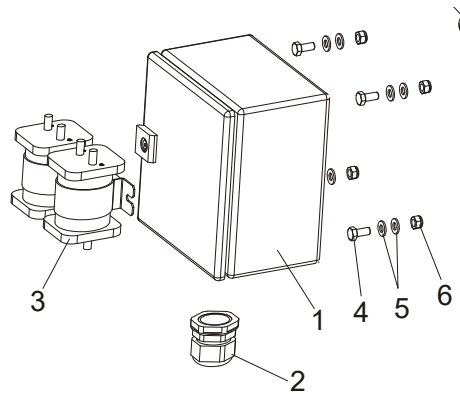

REF.	DESCRIPTION (◆ Indicates Parts Available In Assemblies Only)	PART #	QTY
1	ELECTRIC BOX, LT15 DC COMPLETE	097450	1
	ELECTRIC BOX, LT15 DC COMPLETE (POWER FEED OPTION)	501290	1
2	Connector, PG29	F81096-1	1
	Connector, DP7/H	F81096-11	1
3	Solenoid, 200A 12V DPST	015417	2
4	Bolt, M8x16-8.8-B Hex Head Full Thread Zinc	F81002-20	4
5	Washer, 8.4 Flat Zinc	F81054-1	8
6	Nut, M8-8-B Hex Nylon Zinc Lock	F81032-2	4

6.7 D10 & G15 Engine Mounting Plate

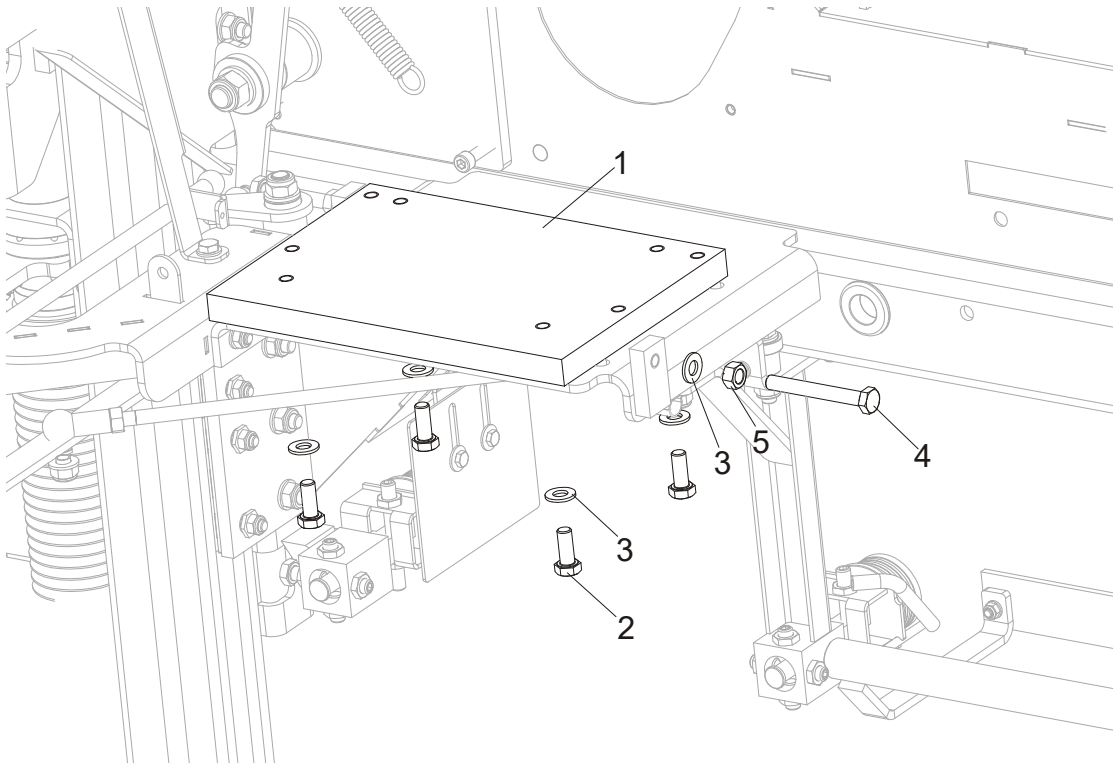

REF.	DESCRIPTION (◆ Indicates Parts Available In Assemblies Only)	PART #	QTY	
1	PLATE, D10, G13, G15 MOTOR MOUNT	506271	1	
2	BOLT, M10X25-8.8 HEX HEAD FULL THREAD ZINC	F81003-11	4	
3	WASHER, 10.5 FLAT ZINC	F81055-1	5	
4	BOLT, M10X80-8.8 HEX HEAD FULL THREAD ZINC	F81003-76	1	
5	NUT, M10-8-B HEX ZINC	F81033-3	1	

6.8 Battery Box

521450_001
521450_MANUAL

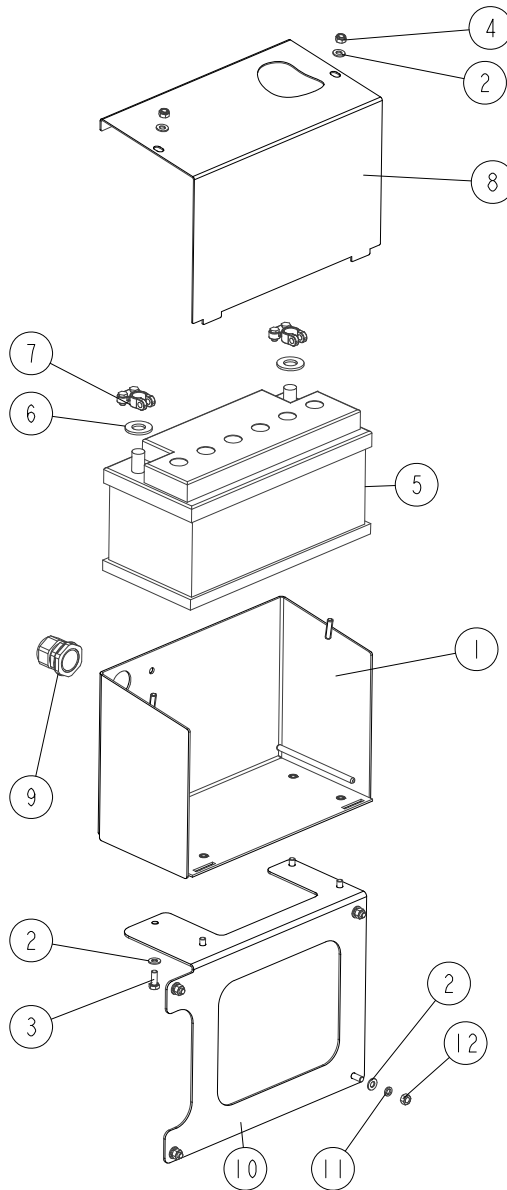

REF.	DESCRIPTION (◆ Indicates Parts Available In Assemblies Only)	PART #	QTY
-	BOX, BATTERY - COMPLETE	521450	1
1	BOX, BATTERY	519920-1	1
2	WASHER, 8.4 FLAT ZINC	F81054-1	10
3	BOLT, M8X20 5.8 HEX HEAD FULL THREAD ZINC	F81002-1	4
4	WASHER, 8.4 FLAT ZINC	F81032-2	2
5	BATTERY, "BANNER" 12V100AH	088323	1
6	WASHER, FELT BATTERY TERMINAL	P12161	2
7	TERMINAL, BATTERY	P05085	2
8	COVER, BATTERY BOX	097489-1	1
9	GLAND, PG29 CABLE	F81096-1	1
10	PLATE WELDMENT, MOUNT	524905-1	1
11	WASHER, 8.2 SPLIT LOCK ZINC	F81054-4	4

REF.	DESCRIPTION (◆ Indicates Parts Available In Assemblies Only)	PART #	QTY	
12	NUT, M8-8-B HEX ZINC	F81032-1	4	

SECTION 7 FEED SYSTEM

7.1 Feed Crank Assembly

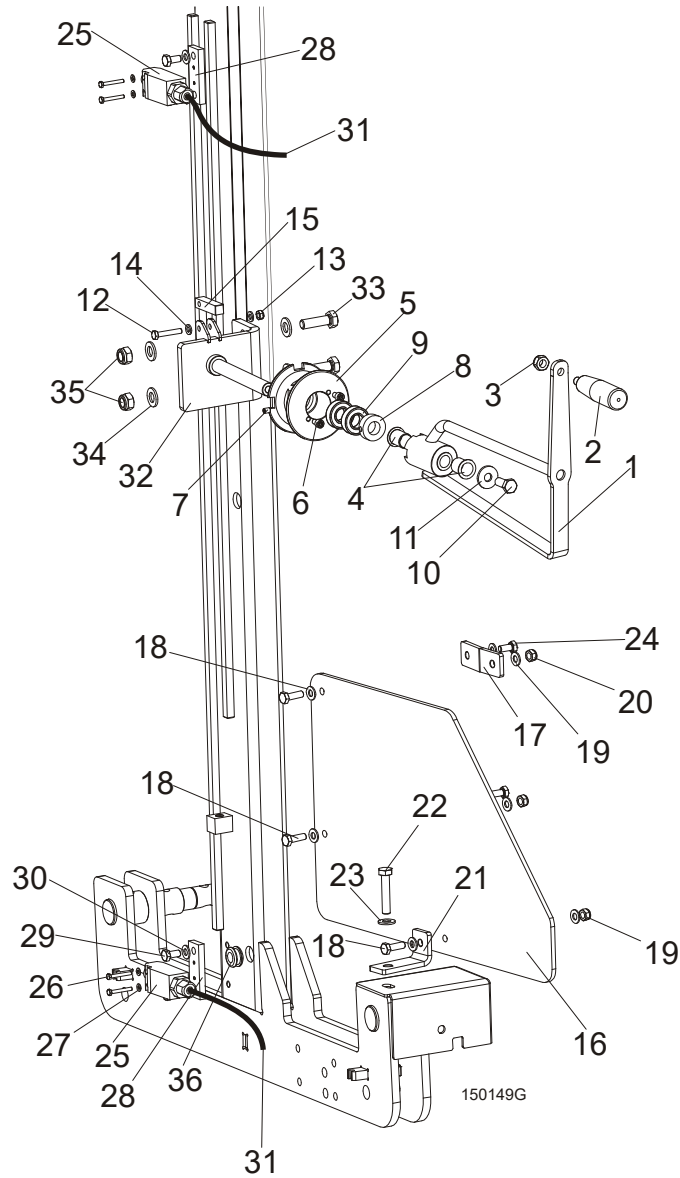

REF.	DESCRIPTION (◆ Indicates Parts Available In Assemblies Only)	PART #	QTY
	MANUAL FEED SYSTEM	094186	1
	Crank Assembly, LT15 Feed	506426	1
1	Crank Weldment, Feed	506427-1	1
2	Knob, 12992M10 Plastic Crank Handle	086338	1
3	Nut, M10-8-B Hex Nylon Zinc Lock	F81033-1	1
4	Bushing, GFM-1719-25	094142	2
5	Pulley, LT15 Feed Rope	086117	1
6	Screw, M6x10-8.8 Hex Socket Head Cap Zinc	F81001-12	2
7	Screw, M6x8 Hex Socket Set Cone Point Zinc	F81013-1	1

8	Ring, 17 Stopping Light Type Zinc-plated	F81039-1	1	
9	Bearing, 6003-2RS FAG Rolling	086116	2	
10	Bolt, M10x25-8.8 Hex Head Full Thread Zinc	F81003-11	1	
11	Washer, 10.5 Special Flat Zinc	F81055-6	1	
12	Bolt, M6x35 8.8 Hex Head Zinc	F81001-71	1	
13	Nut, M6-8-B Hex Nylon Zinc Lock	F81031-2	1	
14	Washer, 6.4 Flat Zinc	F81053-1	2	
15	Pawl, LT15 Detent Zinc-plated	086156-1	1	
	GUARD, LT15 COMPLETE LOWER	093858	1	
16	Plate, LT15 Lower Guard	093859	1	
17	Bracket, Side Painted	086171-1	2	
18	Bolt, M8x25-8.8-B Hex Head Full Thread Zinc	F81002-5	3	
19	Washer, 8.4 Flat Zinc	F81054-1	6	
20	Nut, M8-8-B Hex Nylon Zinc Lock	F81032-2	3	
21	Bracket, Lower Painted	086172-1	1	
22	BOLT, M10X50-8.8 HEX HEAD FULL THREAD ZINC	F81003-4	1	
23	WASHER, 10.5 FLAT ZINC	F81055-1	1	
24	BOLT, M8X16-8.8-B HEX HEAD FULL THREAD ZINC	F81002-20	1	
	EVN2000C LIMIT SWITCH W/MOUNT PLATE	094227	2	
25	Switch, GLCB01C Limit	100910	1	
26	Bolt, M4x30 8.8 Hex Head Full Thread Zinc	F81000-85	2	
27	Washer, 4.3 Flat Zinc	F81051-2	2	
28	Plate, Limit Switch Mount Painted	094228-1	1	
29	Bolt, M8x16 -8.8-B Hex Head Full Thread Zinc	F81002-20	2	
30	Washer, 8.4 Flat Zinc	F81054-1	2	
31	Cable, OLFLEX 400P 2x1	R80583-5	3m	
32	SUPPORT, LT15 MANUAL FEED SYSTEM	501411-1	1	
33	BOLT, M12X40 8.8 HEX HEAD FULL THREAD ZINC	F81004-4	2	
34	WASHER, 13 FLAT ZINC	F81056-1	4	
35	NUT, M12-8 HEX NYLON ZINC LOCK	F81034-2	2	
36	GROMMET, 20/13 RUBBER	086188	1	

7.2 Track Rail, Rollers & Travel Pins

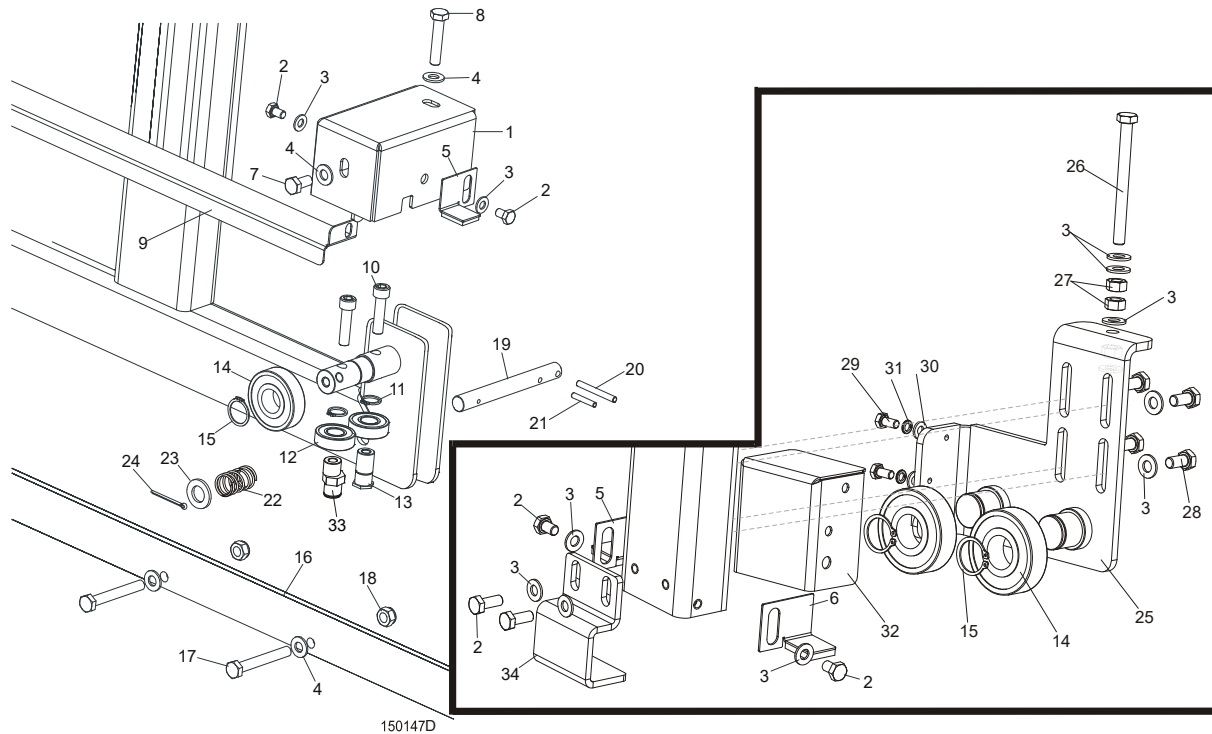

150147D

REF.	DESCRIPTION (◆ Indicates Parts Available In Assemblies Only)	PART #	QTY
1	HOUSING, TRACK ROLLER PAINTED	086739-1	2
2	BOLT, M8X12-8.8 HEX HEAD FULL THREAD ZINC	F81002-6	8
3	WASHER, 8.4 FLAT ZINC	F81054-1	16
4	WASHER, 10.5 FLAT ZINC	F81055-1	13
5	PLATE, RIGHT TRACK WIPER	086322	2
6	PLATE, LEFT TRACK WIPER	086323	2
7	BOLT, M10 X 20 5.8 HEX HEAD FULL THREAD ZINC	F81003-1	2
8	BOLT, M10X50-8.8 HEX HEAD FULL THREAD ZINC	F81003-4	2
9	COVER, MIDDLE TRACK	086745	1
10	SCREW, M10X40 HEX SOCKET HEAD CAP ZINC	F81003-22	4
11	RING, Z 17 OUTSIDE RETAINING	F81090-21	4
12	BEARING, 6203-2RS ROLLING	086114	4
13	SHAFT, SIDE BEARING MOUNT ZINC-PLATED	086645-1	2
14	BEARING, 6305-2RS CX	085706	4
15	RING, 25Z OUTSIDE RETAINING	F81090-22	4
16	RAIL, LT15 1950 (LT15S3) TRACK ZINC-PLATED	094427-1	3
	RAIL, LT15 2700 (LT15M2) TRACK ZINC-PLATED	094696-1	2
17	BOLT, M10X75-8.8 HEX HEAD ZINC	F81003-15	9/13 ¹
18	NUT, M10-8-B HEX NYLON ZINC LOCK	F81033-1	9/13 ²
19	PIN, TRAVEL LOCK ZINC-PLATED	086743-1	2

20	PIN, 6X50 ROLL ZINC	F81045-1	2	
21	PIN, 5 X 30 ROLL ZINC	F81044-21	2	
22	SPRING, 18X37X1.8 COMPRESSION ZINC-PLATED	087301	2	
23	WASHER, 17 FLAT ZINC	F81058-1	2	
24	PIN, 4 X 25 COTTER ZINC	F81043-2	2	
25	BRACKET, ROLLER	506707-1	1	
26	BOLT, M8X90-8.8 HEX HEAD FULL THREAD ZINC	F81002-16	1	
27	NUT, M8-8-B HEX ZINC	F81032-1	3	
28	BOLT, M8X16-8.8-B HEX HEAD FULL THREAD ZINC	F81002-20	4	
29	BOLT, M6X12 8.8 HEX HEAD FULL THREAD ZINC	F81001-7	2	
30	WASHER, 6.4 FLAT ZINC	F81053-1	2	
31	WASHER, Z 6.1 SPLIT LOCK ZINC	F81053-3	2	
32	COVER, ROLLER	501783-1	1	
33	SHAFT, OUTER ECCENTRIC E=3.3-ZINC	098898-1	2	
34	GUIDE, LT15 MAST IDLE SIDE	086202-1	1	

¹ Number of bolts for one bed section.

² Number of nuts for one bed section.

7.3 Feed Rope, V-Groove Rollers & Brackets

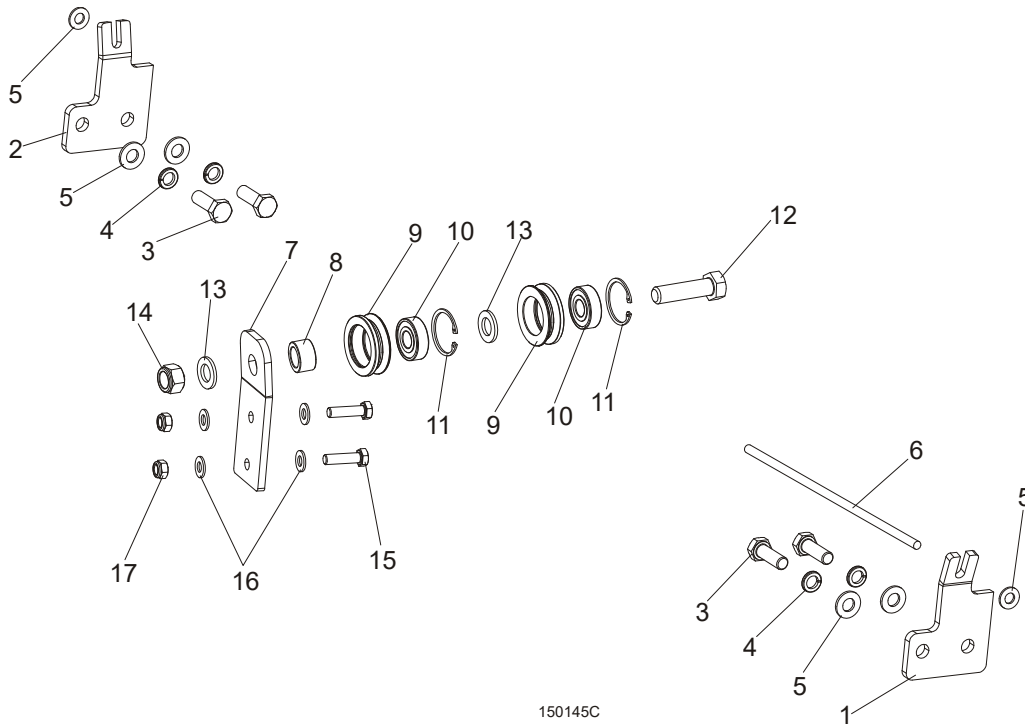

REF.	DESCRIPTION (◆ Indicates Parts Available In Assemblies Only)	PART #	QTY
1	BRACKET, LT15 ROPE MOUNT FRONT	502725-1	1
2	BRACKET, LT15 ROPE MOUNT REAR	502726-1	1
3	BOLT, M10X30-5.8 HEX HEAD FULL THREAD ZINC	F81003-2	4
4	WASHER,10.2 SPLIT LOCK ZINC	F81055-2	4
5	WASHER, 10.5 FLAT ZINC	F81055-1	6
6	ROPE, 5/16" DIA. BRAIDED POLYESTER	R02080	9.0 m
	ROLLER ROPE GUIDE SYSTEM - COMPLETE	502521	1
7	SUPPORT, ROLLER ROPE GUIDE SYSTEM	501955	1
8	SPACER, N25XN16.5X60 BEARING	501415-1	1
	ROLLER ASSEMBLY, V-GROOVE W/BEARING	093855	2
9	ROLLER, V-GROOVE ZINC-PLATED	093856-1	1
10	BEARING, 6203 2RS 5/8 CX	095087	1
11	RING, W40 INSIDE RETAINING	F81090-3	1
12	BOLT, M16X70 8.8 HEX HEAD FULL THREAD ZINC	F81006-16	1
13	WASHER, 17 FLAT ZINC	F81058-1	2
14	NUT, M16-8 HEX NYLON ZINC LOCK	F81036-2	1
15	BOLT, M8X30-8.8 HEX HEAD FULL THREAD ZINC	F81002-7	2
16	WASHER, 8.4 FLAT ZINC	F81054-1	4
17	NUT, M8-8-B HEX NYLON ZINC LOCK	F81032-2	2

7.4 Power Feed System - Optional

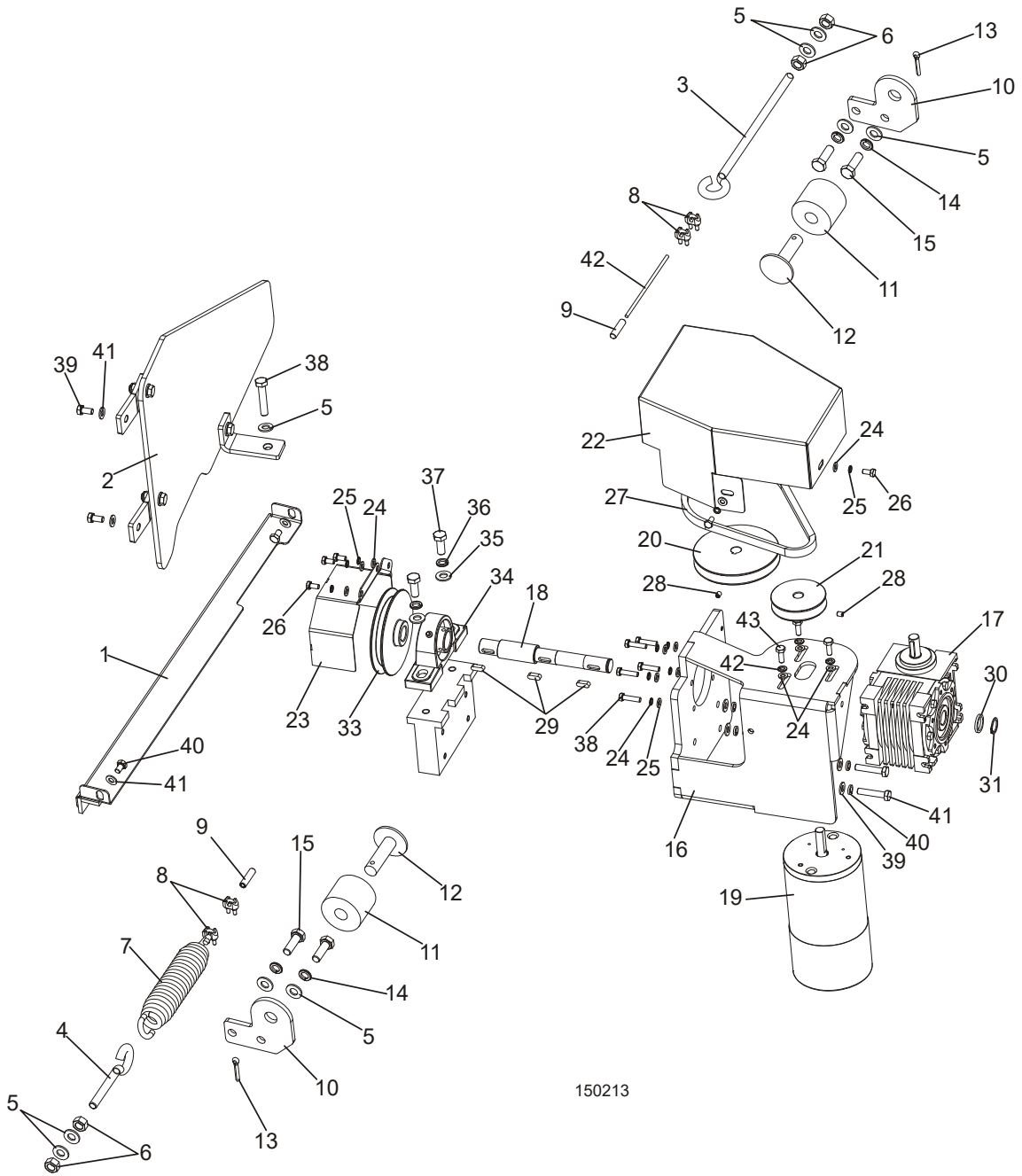

150213

REF.	DESCRIPTION (◆ Indicates Parts Available In Assemblies Only)	PART #	QTY
	POWER FEED ASSEMBLY, LT15DC	500730	1
	JOYSTICK, XD4PA22	087815	1
	CONTACT, ZBE 101	087817	2
1	COVER, LT15 TRACK W/FELT STRIP	500839	1
2	COVER, LT15 LOWER	500727	1
3	TENSIONER, ZINC-PLATED	500846-1	1
4	TENSIONER, SHORT ZINC-PLATED	500848-1	1
5	WASHER, 10.5 FLAT ZINC	F81055-1	9



Feed System

Power Feed System - Optional

6	NUT, M10-8-B HEX ZINC	F81033-3	4	
7	SPRING, PRESS ROLLER ZINC-PLATED	089689-1	1	
8	CLAMP, LT20 STRING	091614	4	
9	POINTER, STEEL CABLE	501417-1	2	
10	PLATE, LT15 POWER FEED SUPPORT	501414-1	2	
11	BUSHING, 11/16x2 1/8x1 3/4 RUBBER	P12165	2	
12	MOUNT WELDMENT, CARRIAGE STOP	086182-1	2	
13	PIN, 4x25 COTTER	F81043-2	2	
14	WASHER, 10.2 SPLIT LOCK ZINC	F81055-2	4	
15	BOLT, M10x30-5.8 HEX HEAD FULL THREAD ZINC	F81003-2	4	
	POWER FEED DRIVE ASSEMBLY, LT15DC	500720	1	
16	BRACKET, MOTOR & REDUCER	501273-1	1	
17	REDUCER, R-40/15.5/F1/V5	500716	1	
18	SHAFT, MOTOREDCER OUTPUT	501267	1	
19	MOTOR, 0.5 HP 12V DC	006747	1	
	Brush Kit, 1/2 HP 12V DC	061794		
20	PULLEY, 117/14	500715-1	1	
21	PULLEY, 75/12.7	500714-1	1	
22	COVER, MAIN COMPLETE	500724-1	1	
23	COVER, FRONT	501505-1	1	
24	WASHER, 6.4 FLAT ZINC	F81053-1	14	
25	WASHER, Z6.1 SPLIT LOCK ZINC	F81053-3	11	
26	BOLT, M6x12-8.8 HEX HEAD FULL THREAD ZINC	F81001-7	6	
27	BELT HA-600	088562	1	
28	SCREW, M6X10-45H ZINC-PLATED	F81001-28	2	
29	KEY, A6X6X18	089404	3	
30	SPACER, D19 IDLER	500868-1	1	
31	RING, 19Z OUTSIDE RETAINING	F81090-20	1	
32	CUBE, MOUNTING	501271-1	1	
33	PULLEY, LT15 POWER FEED ROPE	500864-1	1	
34	BEARING ASSY, UCP205CX	088468	1	
35	WASHER, 10.5 FLAT ZINC	F81055-1	2	
36	WASHER, 10.2 SPLIT LOCK ZINC	F81055-2	2	
37	BOLT, M10X25-8.8 ZINC	F81003-11	2	
38	BOLT, M6X25-5.8 HEX HEAD FULL THREAD ZINC	F81001-3	5	
39	WASHER, 8.4 FLAT ZINC	F81054-1	4	
40	WASHER, 8.2 SPLIT ZINC	F81054-4	4	
41	BOLT, M8X40-8.8 ZINC	F81002-15	4	
42	WASHER, 1/4" UNC ZINC SPLIT LOCK	F81052-21	3	
43	BOLT, 1/4-20x3/4 FT HHC	F05005-1	3	
44	BOLT, M10X35-8.8 HEX HEAD FULL THREAD ZINC	F81003-17	1	
45	BOLT M8x16 -8.8-B HEX HEAD FULL THREAD ZINC	F81002-20	2	
46	BOLT, M8X12-8.8 HEX HEAD FULL THREAD ZINC	F81002-6	2	
47	WASHER, 8.4 FLAT ZINC	F81054-1	4	

48	CABLE, STEEL ZINC-PLATED Φ4 L=5450MM	R80663-2S	1	
	CABLE, STEEL ZINC-PLATED Φ4 L=7400MM	R80663-3S	1	
	CABLE, STEEL ZINC-PLATED Φ4 L=9350MM	R80663-4S	1	
	CABLE, STEEL ZINC-PLATED Φ4 L=6950MM	R80663-2M	1	
	CABLE, STEEL ZINC-PLATED Φ4 L=9650MM	R80663-3M	1	
	CABLE, STEEL ZINC-PLATED Φ4 L=12350MM	R80663-4M	1	

SECTION 8 UP/DOWN SYSTEM

8.1 Up/Down Assembly, DC

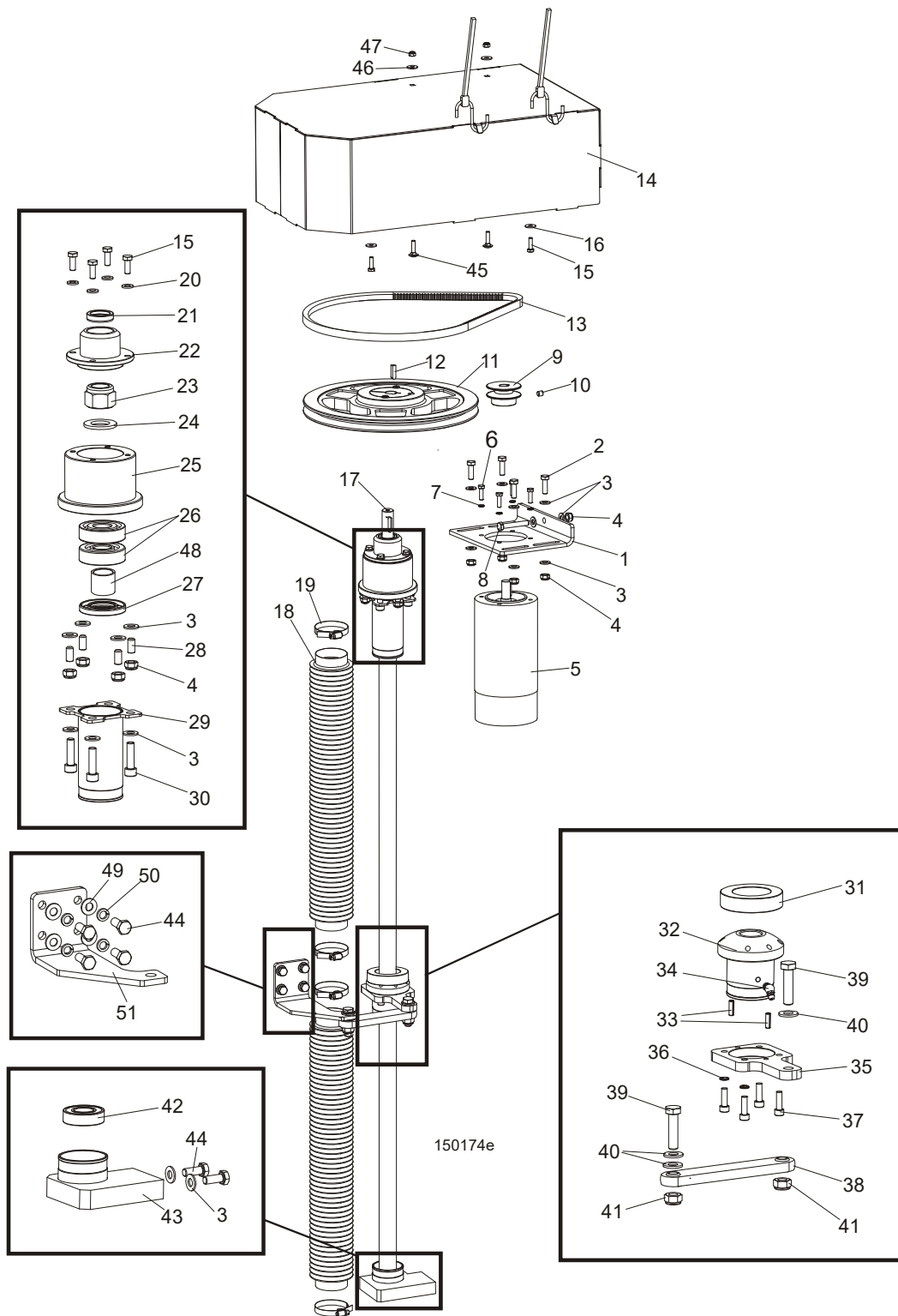

REF.	DESCRIPTION (◆ Indicates Parts Available In Assemblies Only)	PART #	QTY
	UP/DOWN DRIVE - DC, COMPLETE	095253	1
1	Plate, Drive Belt Tension	094162-1	1
2	Bolt, M8x25-8.8-B Hex Head Full Thread Zinc	F81002-5	4
3	Washer, 8.4 Flat Zinc	F81054-1	22
4	Nut, M8-8-B Hex Nylon Zinc Lock	F81032-2	9
5	Motor, Drive 12V 0.5HP	006747	1
	Brush Kit, 1/2 HP 12V DC	061794	
6	Bolt, 1/4-20x3/4 FT HHC	F05005-1	4
7	Washer, 6.4 Flat Zinc	F81053-1	4
8	Bolt, M8x50-8.8 Hex Head Full Thread Zinc	F81002-19	1
9	Pulley, LT15DC Up/Down Motor	095340-1	1
10	Screw, M8x8-33H Hex Socket Set Flat Point Zinc	F81014-1	2
11	Pulley, SPA 280/1 w/18 Split Taper Bushing	094157	1
12	Key, AB 6x6x23 Parallel	089191	1
13	V-belt, AVX-13x1100 La	095306	1
14	Cover, Up/Down System LT15 Complete High	096948	1
	Strap, 24 in rubber with hooks	P11258	2
15	Bolt, M6x20-8.8 Hex Head Full Thread Zinc	F81001-2	8
16	Washer, 6.4 Flat Zinc	F81053-11	4
17	Screw, Tr 28x5 Acme	094144	1
18	Bellows, 50/700 Protective	094208	2
19	Clamp, 40-60mm	F81095-4	4
20	Washer, 6.4 Flat Zinc	F81053-1	4
21	Ring, A018x30x7 Sealing	094159	1
22	Cover, Up/Down Bearing Housing	094165-1	1
23	Nut, M20x1.5-8-A2 ISO10512 Self-locking	F81037-5	1
24	Washer, 21 Flat Zinc	F81059-2	1
25	Housing, Up/Down Bearings	094164-1	1
26	Bearing, 7304B -UO CX	094256	2
27	Ring, A28x52x7 Sealing	094155	1
28	Screw, M8x16-33H Hex Socket Set Flat Point	F81014-2	4
29	Bracket, Upper Bellows Mount Zinc-plated	094221-1	2
30	Screw, M8x30-8.8 Hex Socket Head Cap Zinc	F81002-31	4
31	Washer, DIN6319-42-C Spherical Seat	F81061-7	1
	Up/Down Nut Assembly	094150	1
32	Nut, TR28 X 5 Acme Screw	505315	1
33	Pin, 5x16 Roll Zinc	F81044-3	2
34	Fitting, M6 "B" Type PN-M/86003 Grease	094213	1
35	Plate, Nut Housing Seat	094242-1	1
36	Washer, Z 6.1 Split Lock Zinc	F81053-3	4
37	Screw, M6x20-8.8 Hex Socket Head Cap Zinc	F81001-22	4
38	Link, SBPL 10104 Pivotal	097700	1
39	Bolt, M10x40-8.8 Hex Head Full Thread Zinc	F81003-16	2
40	Washer, 10.5 Flat Zinc	F81055-1	3
41	Nut, M10-8-B Hex Nylon Zinc Lock	F81033-1	2
42	Bearing, 6004 2RS-CX Rolling	093868	1
43	Seat, Lower Bearing	093866-1	1



Up/Down System

Up/Down Assembly, DC

44	Bolt, M8x20-8.8-B Hex Head Full Thread Zinc	F81002-4	6	
45	Bolt, M6x25-8.8 Mushroom Head Square Neck Zinc	F81001-20	2	
46	Washer, 6.5 Special Flat Zinc	F81053-11	2	
47	Nut, M6-8-B Hex Nylon Zinc Lock	F81031-2	2	
48	Spacer, LT15 Drive Bearing	094156-1	1	
49	Washer, 8.4 Flat Zinc	F81054-1	4	
50	Washer 8.2 Split Lock Zinc	F81054-4	4	
51	Bracket Link, SBPL 10104 Pivotal	511217-1	1	

8.2 Service Kit, LT15 Up/Down System

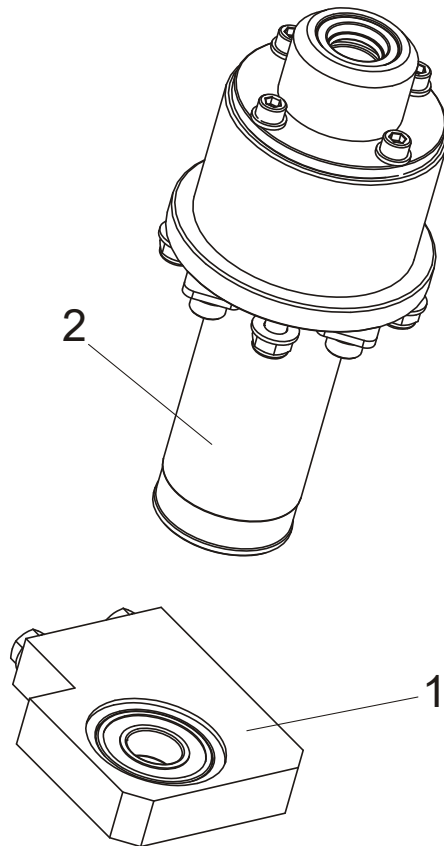

REF.	DESCRIPTION (◆ Indicates Parts Available In Assemblies Only)	PART #	QTY	
	SERVICE KIT, LT15 UP/DOWN SYSTEM	512233	1	
1	SEAT, LOWER BEARING, COMPLETE	512231	1	
2	HOUSING, UP/DOWN BEARING	512232	1	

8.3 Slide Pads & Blade Height Scale Indicator

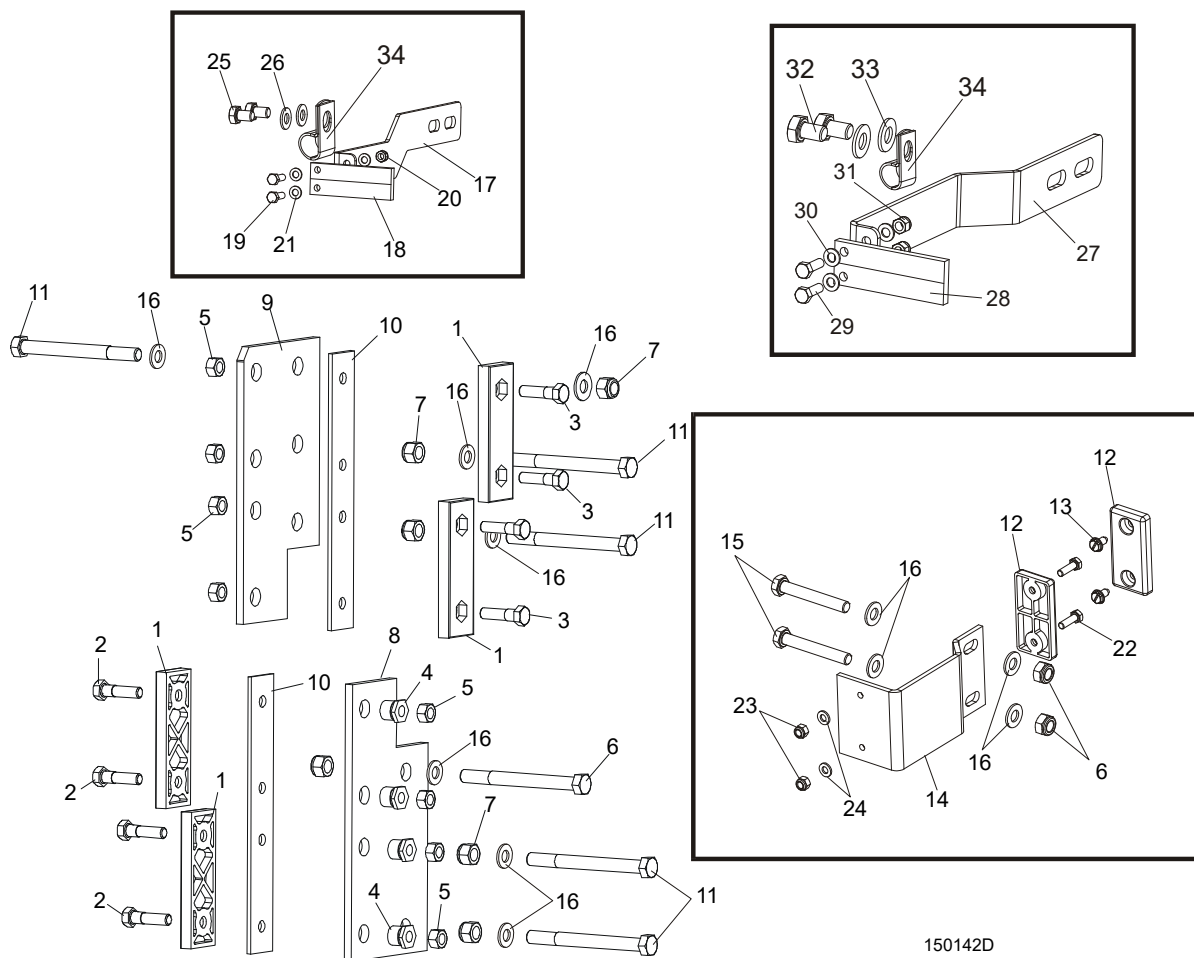

150142D

REF.	DESCRIPTION (◆ Indicates Parts Available In Assemblies Only)	PART #	QTY
1	PADS, DELRIN UP/DOWN SLIDE	M04096	4
2	BOLT, M8X35-8.8 HEX HEAD FULL THREAD ZINC	F81002-13	4
3	BOLT, M8X20-8.8 HEX HEAD FULL THREAD ZINC	F81002-4	4
4	NUT, LT15 SLIDE PAD ADJUSTMENT	086683-1	4
5	NUT, M8-8-B HEX NYLON ZINC LOCK	F81032-2	8
6	BOLT, M10X110 8.8 HEX HEAD ZINC	F81003-43	1
7	NUT, M10-8-B HEX NYLON ZINC LOCK	F81033-1	8
8	PLATE, SAW HEAD LOWER GUIDE PAINTED	086682-1	1
9	PLATE, SAW HEAD UPPER GUIDE PAINTED	094139-1	1
10	PLATE, SLIDE PAD SPACER PAINTED	094140-1	2
11	BOLT, M10X115-8.8 HEX HEAD ZINC	F81003-19	5
12	PAD, IDLE SIDE SLIDE	P13576	2
13	SCREW, 1/4-20 X 1/2" "23" TYPE SELF-TAPPING	F05015-1	2
14	GUIDE, LT15 SAW HEAD PAINTED	087192-1	1

15	BOLT, M10X70-8.8 HEX HEAD FULL THREAD ZINC	F81003-20	2	
16	WASHER, 10.5 FLAT ZINC	F81055-1	11	
	SCALE INDICATOR (STANDARD)	094226	1	
17	Bracket, Scale Indicator Mount	094224-1	1	
18	Indicator, Blade Height Scale	094821	1	
19	Bolt, M5NX16-8.8 Hex Head Full Thread Zinc	F81000-20	2	
20	Nut, M5-8 DIN 985 Zinc-Plated	F81030-2	2	
21	Washer, 5.3 Flat Zinc	F81052-1	4	
22	BOLT, M6X20-8.8 HEX HEAD FULL THREAD ZINC	F81001-2	2	
23	NUT, M6-8-B HEX NYLON ZINC LOCK	F81031-2	2	
24	WASHER, 6.4 FLAT ZINC	F81053-1	2	
25	BOLT, M8X12-8.8 HEX HEAD FULL THREAD ZINC	F81002-6	2	
26	WASHER, 8.4 FLAT ZINC	F81054-1	2	
	SCALE INDICATOR (OPTIONAL)	095967		
27	Bracket, Scale Indicator Mount	095968-1	1	
28	Indicator, Blade Height Scale	094821	1	
29	Bolt, M5X16-8.8 Hex Head Full Thread Zinc	F81000-20	2	
30	Washer, 5.3 Flat Zinc	F81052-1	4	
31	Nut, M5-8 DIN 985 Zinc-plated	F81030-2	2	
32	Bolt, M8x12-8.8 Hex Head Full Thread Zinc	F81002-6	2	
33	Washer, 8.4 Flat Zinc	F81054-1	2	
34	CLAMP, 1/2" EMT COATED	P07584	1	

8.4 Blade Height Scale & Up/Down Limit Switches

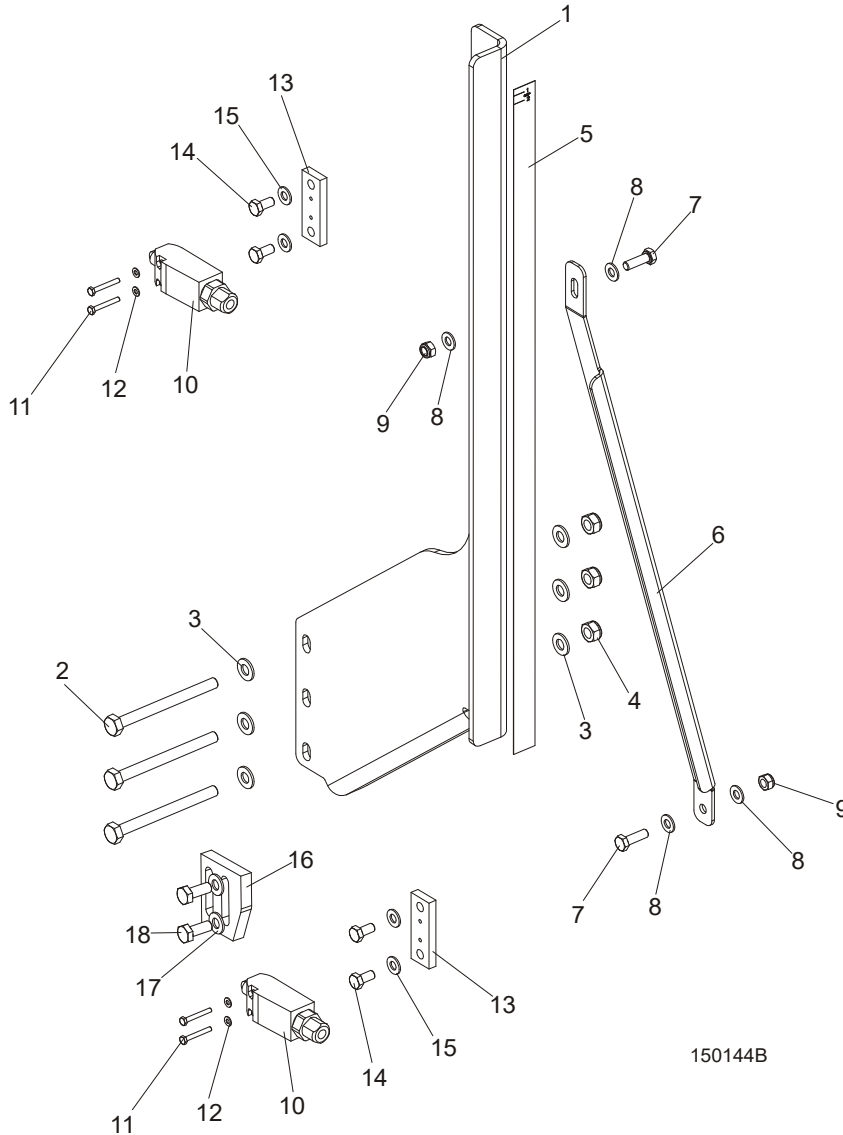

150144B

REF.	DESCRIPTION (◆ Indicates Parts Available In Assemblies Only)	PART #	QTY
	BRACKET, BLADE HEIGHT SCALE, COMPLETE	094225	1
1	Bracket, Blade Height Scale	094223-1	1
2	Bolt, M10X115-8.8 Hex Head Zinc	F81003-19	3
3	Washer, 10.5 Flat Zinc	F81055-1	6
4	Nut, M10-8-B Hex Nylon Zinc Lock	F81033-1	3
5	Decal, LT15AC Blade Height Metric Scale	094151	1
	Decal, LT15AC Blade Height Inch Scale	096658	1
6	BRACKET, BLADE HEIGHT SCALE MOUNT	094257-1	1
7	BOLT, M8X25-8.8-B HEX HEAD FULL THREAD ZINC	F81002-5	2
8	WASHER, 8.4 FLAT ZINC	F81054-1	4

9	NUT, M8-8-B HEX NYLON ZINC LOCK	F81032-2	2	
	EVN2000C LIMIT SWITCH W/MOUNT PLATE	094227	2	
10	Switch, GLCB01C Limit	100910	1	
11	Bolt, M4x30 8.8 Hex Head Full Thread Zinc	F81000-85	2	
12	Washer, 4.3 Flat Zinc	F81051-2	2	
13	Plate, Limit Switch Mount	094228-1	1	
14	Bolt, M8x16-8.8-B Hex Head Full Thread Zinc	F81002-20	2	
15	Washer, 10.5 Flat Zinc	F81055-1	2	
16	BRACKET, LIMIT SWITCH	094229-1	1	
17	WASHER, 8.4 FLAT ZINC	F81054-1	2	
18	BOLT, M8x20-8.8-B HEX HEAD FULL THREAD ZINC	F81002-4	2	

8.5 Blade Height Scale (Optional)

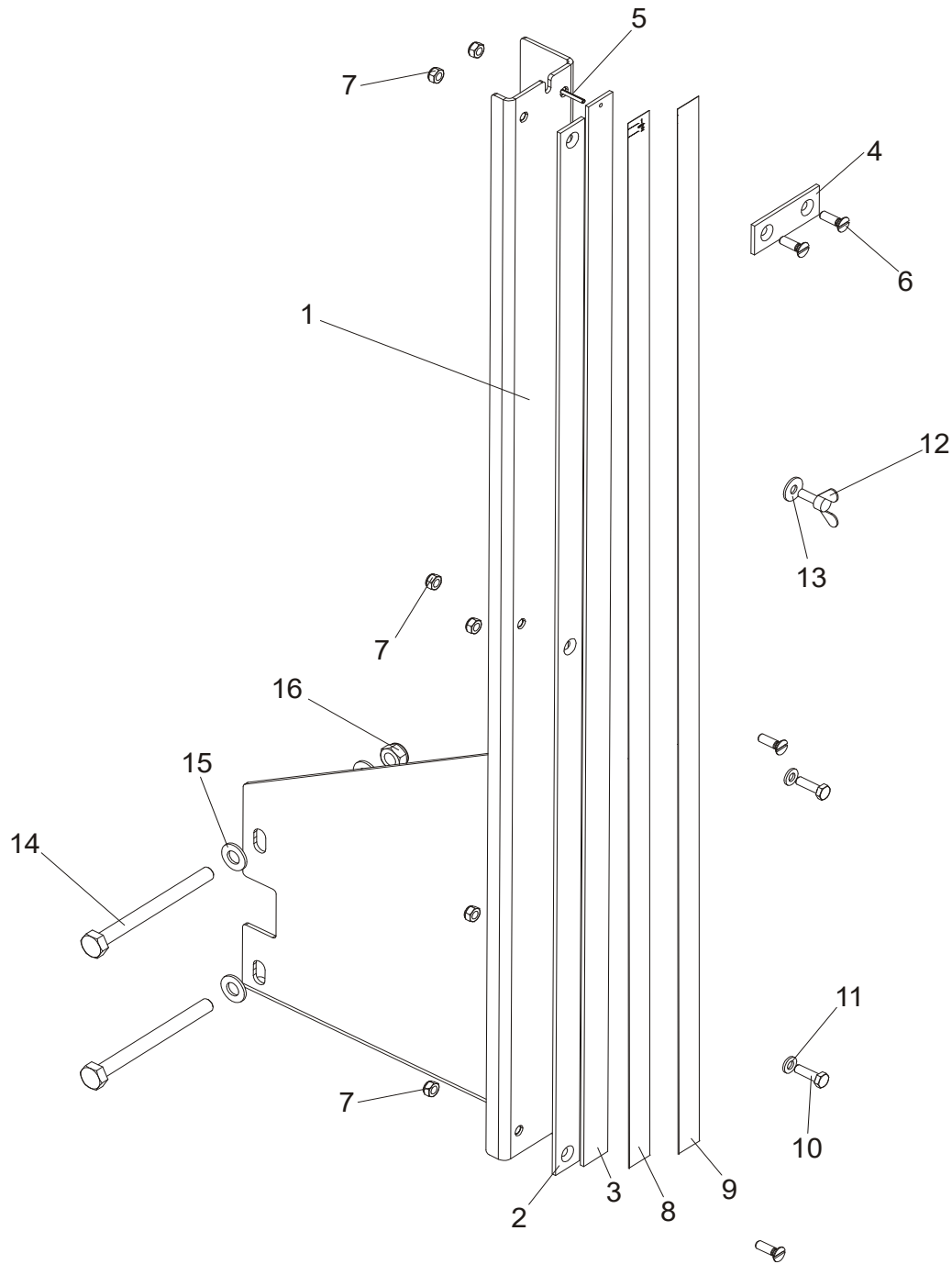

REF.	DESCRIPTION (◆ Indicates Parts Available In Assemblies Only)	PART #	QTY
	BRACKET, BLADE HEIGHT SCALE - COMPLETE	095964	1
1	Bracket, Blade Height Scale	095965-1	1
2	Plate, Decal Mount	092750	1
3	Plate, Inch Decal Mount	093133	1
4	Bar, Scale Mount	093134	1
5	Pin, 3x20 Roll Zinc	F81044-5	1

6	Screw, M6x20- 4.8-B Slotted Countersunk Head Zinc	F81001-31	3	
7	Nut, M6-8-B Hex Nylon Zinc Lock	F81031-2	6	
8	Decal, LT20 0-80cm Centimeter Scale	091239	1	
9	Decal, 16-40CM Metric Decal, 45-63CM Metric	P12040-1 P12040-2	1	
10	BOLT, M6X20-8.8 HEX HEAD FULL THREAD ZINC	F81001-2	2	
11	WASHER, 6.4 FLAT ZINC	F81053-1	2	
12	SCREW, M6X16 BN276 DIN 316 WING	F81001-16	1	
13	WASHER, 6.5 SPECIAL FLAT ZINC	F81053-11	1	
14	BOLT, M10X115-8.8 HEX HEAD ZINC	F81003-19	2	
15	WASHER, 10.5 FLAT ZINC	F81055-1	4	
16	NUT, M10-8-B HEX NYLON ZINC LOCK	F81033-1	2	