

# Wood-Mizer<sup>®</sup> Sawmill

## Safety, Setup, Operation & Maintenance Manual

---

<b>LT15 G13</b>	<b>rev. B4.00</b>
<b>LT15 E11</b>	<b>rev. B4.00</b>
<b>LT15 D10</b>	<b>rev. B4.00</b>

---



**Safety is our #1 concern!** Read and understand all safety information and instructions before operating, setting up or maintaining this machine.

*February 1998*

*Form #798*

This manual is to replace or to be used with all previous information received on the Wood-Mizer® sawmill. All future mailings will be an addition to or a revision of individual sections of this manual as we obtain new information.

The information and instructions given in this manual do not amend or extend the limited warranties for the equipment given at the time of purchase.

### ***If You Need To Order Parts...***

From Europe call our European Headquarters and Manufacturing Facility in Kolo, Poland at **+48-63-2610233** or **+48-3912-1319**. From the continental U.S., call our toll-free Parts hotline at **1-800-448-7881**. Please have the vehicle identification number and your customer number ready when you call. Wood-Mizer will accept these methods of payment:

- Visa, Mastercard, or Select Purchase
- COD
- Prepayment
- Net 15 (with approved credit)

Be aware that shipping and handling charges may apply. Handling charges are based on size and quantity of order. In most cases, items will ship on the day they are ordered. Second Day and Next Day shipping are available at additional cost.

### ***If You Need Service...***

From Europe call our European Headquarters and Manufacturing Facility in Kolo, Poland at **+48-63-2610233** or **+48-3912-1319**. From the continental U.S., call us toll-free at **1-800-525-8100**. Ask to speak with a Customer Service Representative. Please have your vehicle identification number and your customer number ready when you call. The Service Representative can help you with questions about alignment of your mill, blade sharpening, or cutting a particular species of wood. He also can schedule you for a service call.

**Office Hours:** All times are Eastern Standard Time. Please remember that Indiana does not go on Daylight Savings Time in the summer.

Country	Monday - Friday	Saturday	Sunday
U.S., Indiana	8 a.m. to 5 p.m.	8 a.m. to 4 p.m.	Closed
Poland	8 a.m. to 4:30 p.m.	8 a.m. to 1 p.m.	Closed



**IMPORTANT!** Read the entire Operator's Manual before operating the sawmill. Take notice of all safety warnings throughout this manual and those posted on the machine. Keep this manual with this machine at all times, regardless of ownership.

\*Wood-Mizer® is a registered trademark of Wood-Mizer Products, Inc.

## **Sawmill and Customer Identification**

Each Wood-Mizer LT15 sawmill is identified with a revision and VIN numbers.

The VIN number contains the month, year and place of manufacture, the base model and the engine/motor configuration. The revision number helps identify the exact design of the equipment. See the figure for a description of the revision number.

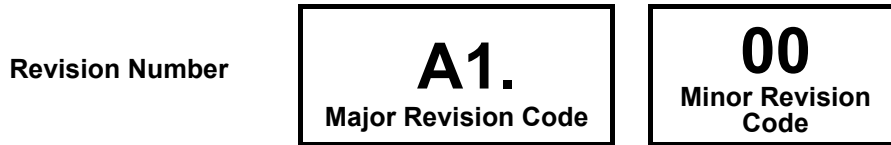

### ***REVISION NUMBER DESCRIPTION.***

When you pick up your mill, you will receive a customer number. The VIN number, revision, and your customer number expedite our service to you. Please write these numbers below so you have quick, easy access to them.

<b>Customer No.</b>	<b>VIN No.</b>	<b>Revision No.</b>



# Table of Contents

# Section-Page

## **SECTION 1 SAFETY & GENERAL INFORMATION 1-1**

1.1	Blade Handling.....	1-2
1.2	Sawmill Setup.....	1-2
1.3	Sawmill Operation.....	1-3
1.4	Sawmill Maintenance.....	1-5
1.5	Belt Sizes.....	1-7
1.6	Blade Sizes.....	1-7
1.7	Cutting Capacity.....	1-8
1.8	Engine/Motor Specifications.....	1-8
1.9	Overall Dimensions.....	1-9
1.10	Components.....	1-10
1.11	Electrical Information.....	1-11

## **SECTION 2 SAWMILL ASSEMBLY 2-1**

2.1	Frame Assembly.....	2-1
2.2	Frame Leg Adjustment.....	2-3
2.3	Saw Carriage Assembly.....	2-4
2.4	Feed Rope Assembly.....	2-5
2.5	Engine Assembly.....	2-9
2.6	Auxiliary Bed Rail.....	2-11

## **SECTION 3 SETUP & OPERATION 3-1**

3.1	Sawmill Setup.....	3-1
3.2	Replacing The Blade.....	3-3
3.3	Tensioning The Blade.....	3-4
3.4	Tracking The Blade.....	3-5
3.5	Starting The Engine.....	3-7
3.6	Loading, Turning, And Clamping Logs.....	3-8
3.7	Up/Down Operation.....	3-12
3.8	Blade Guide Arm Operation.....	3-13
3.9	Blade Drive Operation.....	3-14
3.10	Feed Operation.....	3-17
3.11	Cutting The Log.....	3-18
3.12	Edging.....	3-20
3.13	Blade Height Scale.....	3-21
3.14	Water Lube Operation.....	3-22
3.15	Transporting the Sawmill.....	3-24

# Table of Contents

# Section-Page

## SECTION 4 MAINTENANCE

4-1

4.1	Wear Life.....	4-1
4.2	Sawdust Removal.....	4-1
4.3	Carriage Track & Rollers.....	4-2
4.4	Vertical Mast Rails.....	4-2
4.5	Miscellaneous Lubrication.....	4-3
4.6	Blade Wheel Belts.....	4-4
4.7	Up/Down System.....	4-4
4.8	Miscellaneous Maintenance.....	4-5

## SECTION 5 TROUBLESHOOTING GUIDE

5-1

5.1	Sawing Problems.....	5-1
-----	----------------------	-----

## SECTION 6 ALIGNMENT

6-1

6.1	Pre-Alignment Procedures.....	6-1
6.2	Preparing The Sawmill For Alignment.....	6-2
6.3	Blade Installation and Alignment.....	6-3
6.4	Blade Guide Arm Alignment.....	6-5
6.5	Aligning The Blade Guides.....	6-7
6.6	Blade Deflection.....	6-8
6.7	Blade Guide Vertical Tilt Adjustment.....	6-9
6.8	Blade Guide Spacing.....	6-11
6.9	Horizontal Tilt Adjustment.....	6-12
6.10	Side Supports.....	6-13
6.11	Blade Height Scale Adjustment.....	6-14

## SECTION 1 SAFETY & GENERAL INFORMATION



This symbol calls your attention to instructions concerning your personal safety. Be sure to observe and follow these instructions. This symbol accompanies a signal word. The word **DANGER** indicates an imminently hazardous situation which, if not avoided, will result in death or serious injury. **WARNING** suggests a potentially hazardous situation which, if not avoided, could result in death or serious injury. **CAUTION** refers to potentially hazardous situations which, if not avoided, may result in minor or moderate injury to persons or equipment. Read all safety instructions before operating this equipment and observe all safety warnings!



Warning stripes are placed on areas where a single decal would be insufficient. To avoid serious injury, keep out of the path of any equipment marked with warning stripes.

Read and observe all safety instructions before operating this equipment! Also read any additional manufacturer's manuals and observe any applicable safety instructions including dangers, warnings, and cautions.

Always be sure that all safety decals are clean and readable. Replace all damaged safety decals to prevent personal injury or damage to the equipment. Contact your local distributor, or call your Customer Service Representative to order more decals.

**IMPORTANT!** It is always the owner's responsibility to comply with all applicable federal, state and local laws, rules and regulations regarding the ownership and operation of your Wood-Mizer sawmill. All Wood-Mizer mill owners are encouraged to become thoroughly familiar with these applicable laws and comply with them fully while using the mill.

Always properly dispose of all sawing by-products, including sawdust and other debris, coolant, oil, fuel, oil filters and fuel filters.

Safety instructions are listed in this section by the following operations:

- Blade Handling
- Sawmill Setup
- Sawmill Operation
- Sawmill Maintenance

## 1.1 Blade Handling



**DANGER!** Always disengage the blade and shut off the sawmill engine before changing the blade. Failure to do so will result in serious injury.



**WARNING!** Always wear gloves and eye protection when handling bandsaw blades. Changing blades is safest when done by one person! Keep all other persons away from area when coiling, carrying or changing a blade. Failure to do so may result in serious injury.

## 1.2 Sawmill Setup



**WARNING!** Do not set up the mill on ground with more than a 10 degree incline. If setup on an incline is necessary, put blocks under one side of the mill or dig out areas for the legs to keep mill level. Setting up the mill on an incline could cause it to tip over, resulting in serious personal injury.

**WARNING!** Keep all persons out of the path of the saw head while loading and unloading the sawmill. Failure to do so may result in serious injury or death.



### 1.3 Sawmill Operation



**DANGER!** Make sure all guards and covers are in place and secured before operating or towing the sawmill. Failure to do so may result in serious injury.

**DANGER!** Be sure the blade housing and pulley covers are in place and secured.

**DANGER!** Always keep hands away from moving bandsaw blade. Failure to do so will result in serious injury.

**DANGER!** Keep all persons out of the path of moving equipment and logs when operating sawmill or loading and turning logs. Failure to do so will result in serious injury.

**DANGER!** Maintain a clean and clear path for all necessary movement around the mill and lumber stacking areas. Failure to do so will result in serious injury.

**DANGER!** Always be sure the blade is disengaged and all persons are out of the path of the blade before starting the engine or motor. Failure to do so will result in serious injury.



**WARNING!** Always disengage the clutch/brake mechanism whenever the sawmill is not cutting. Failure to do so may result in serious injury.

**WARNING!** Always wear eye, ear, respiration, and foot protection when operating the sawmill. Failure to do so may result in serious injury.



**WARNING!** Secure all loose clothing and jewelry before operating the sawmill. Failure to do so may result in serious injury or death.

**WARNING!** Always make sure log is clamped securely before sawing. Failure to do so may result in serious injury or death.

**WARNING!** Use ONLY water with the water lube accessory. Never use flammable fuels or liquids. If these types of liquids are necessary to clean the blade, remove it and clean with a rag. Failure to do so may result in serious injury or death.



**CAUTION!** Be sure the log clamps are all the way down before loading a log onto the bed. Failure to do so may

result in machine damage.

**CAUTION!** Before loading a log, be sure the cutting head is moved far enough forward so the log does not hit it. Failure to do so may result in machine damage.

**CAUTION!** Do not try to force the saw head beyond its upper and lower travel limits. Damage to the up/down system may result.

**CAUTION!** Be sure to stop the blade when returning the carriage. This will not only prevent the blade from being pulled off and ruined by a wood sliver, but also will increase the life of the blade.

**CAUTION!** The saw head will hit the spring-loaded ramp stops when adjusted for low cuts. Remove the loading ramps before sawing to prevent damage to the saw head and/or blade guide arm.

## 1.4 Sawmill Maintenance



**WARNING!** Always secure the cutting head with a chain or a brace before adjusting the up/down chain. The cutting head may fall, causing severe injury or death.

**WARNING!** Always secure the cutting head with a chain or a brace before adjusting the mast pads. The cutting head may fall, causing severe injury or death.



**CAUTION!** Do not over-grease the blade guide bearings. Over-greasing will push the seals out of the bearings causing premature failure.

**CAUTION!** Never use grease on the mast rails as it will collect sawdust.

**CAUTION!** Do not use chain lube. It causes sawdust buildup in chain links.

Pictogram decals used to warn the user about danger in the LT15:

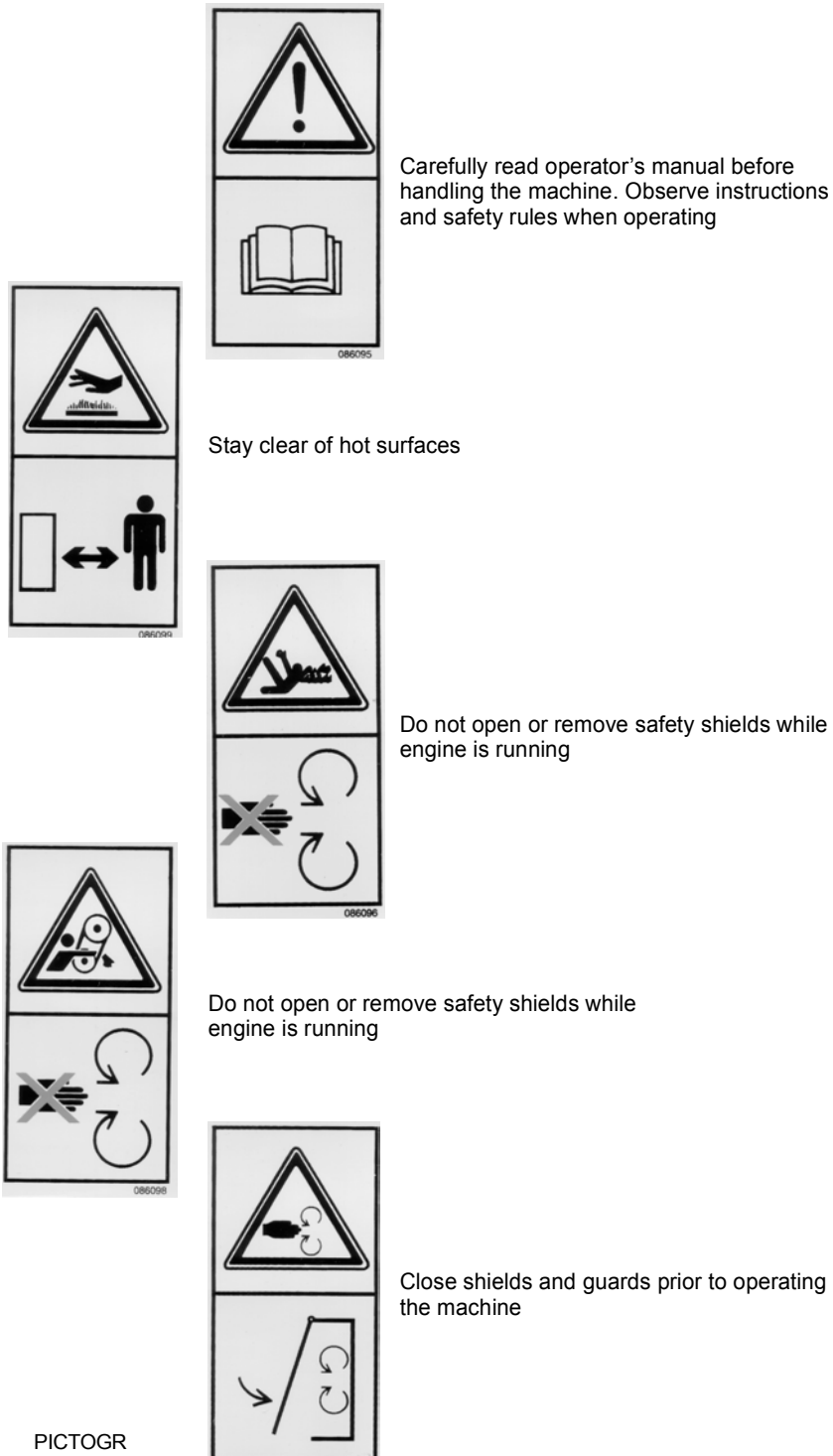

**FIG. 1-0**

## 1.5 Belt Sizes

See Table 1-1. Belt sizes for the LT15 are shown.

Description	Belt Size	Wood-Mizer Part #
Motor Drive Belt (E11)	BX81	014819
Engine Drive Belt (G13)	BX81	014819
Blade Pulley Belts	B57 <sup>1</sup>	P04185
Engine Drive Belt (D10)	HB2155Li	092361

TABLE 1-1

<sup>1</sup> To insure proper blade tracking, use Goodyear, Dayco Super II, or Browning belts only.

## 1.6 Blade Sizes

See Table 1-2. Wood-Mizer TRU•SHARP™ offers three types of blades to provide efficient sawing for all models of sawmills. The engine/motor size of your sawmill and the type of wood you saw should determine which blade you choose for optimum performance.

Engine/Motor Size	Recommended Blade For Sawing:		
	Softwood	Hardwood	Frozen or Hard-to-Cut Wood
5 hp - 15hp	.042 x 7/8 x 1 1/4"	.035 x 7/8 x 1 1/4"	.045 x 7/8 x 1 1/4" F1 <sup>1</sup>
16hp or more	.045 x 7/8 x 1 1/2"	.042 x 7/8 x 1 1/4" .045 x 7/8 x 1 1/2" <sup>2</sup>	.045 x 7/8" x 1 1/4" F1 <sup>1</sup>
Electric Motor	.045 x 7/8 x 1 1/2"	.042 x 7/8 x 1 1/4" .045 x 7/8 x 1 1/2" <sup>2</sup>	.045 x 7/8 x 1 1/4" F1 <sup>1</sup>

TABLE 1-2

<sup>1</sup> TRU•SHARP™ "F" blades use a 9/29 profile (9° hook angle and 29° back angle) and are designed to cut frozen and/or extremely dense, hard-to-cut wood. Standard TRU•SHARP™ blades use a 10/30 profile.

<sup>2</sup> Customer may choose preferred blade.

See *The Blade Handbook* for blade hook angle, tooth height, and tooth set specifications.

## 1.7 Cutting Capacity

See Table 1-3. The log size capacities of the LT15 sawmills are listed below.

	Max. Diameter	Max. Length <sup>1</sup>
LT15	28" (71 cm)	18' (5,4 m)
LT15/2	28" (71 cm)	11,5' (3,5 m)

**TABLE 1-3**

<sup>1</sup> Each additional bed frame segment adds approximately 195 cm ( 6' 5" ) to length capacity.

See Table 1-4. The performance capacity of the LT15 sawmill is listed below. Peak cutting rates are measured in 12" (30 cm) wide red oak and represent the capability of the sawmill only. Rates based on using Tru-Sharp 1 1/4" x .042 blades.

Model	Cutting Rate
LT15 E11, G13, D10	16 ft. (3.3 m)/min.

**TABLE 1-4**

## 1.8 Engine/Motor Specifications

See Table 1-5. The power options available for the LT15 sawmill are listed below.

Engine/Motor Type	Manufacturer	Model No.	Specification
Motor (7.5 kW)	Tamel S.A., Poland	Sg112M-2PE	3 x 380V, 50 Hz
13HP Gasoline	Kohler	CH13T Spec #PA22519	398 ccm
Motor (10HP)	Yanmar, Japan	L100	406 ccm, 3600 min <sup>-1</sup>

**TABLE 1-5**

## 1.9 Overall Dimensions

See Figure 1-1. The overall dimensions of the LT15 sawmills are shown below.

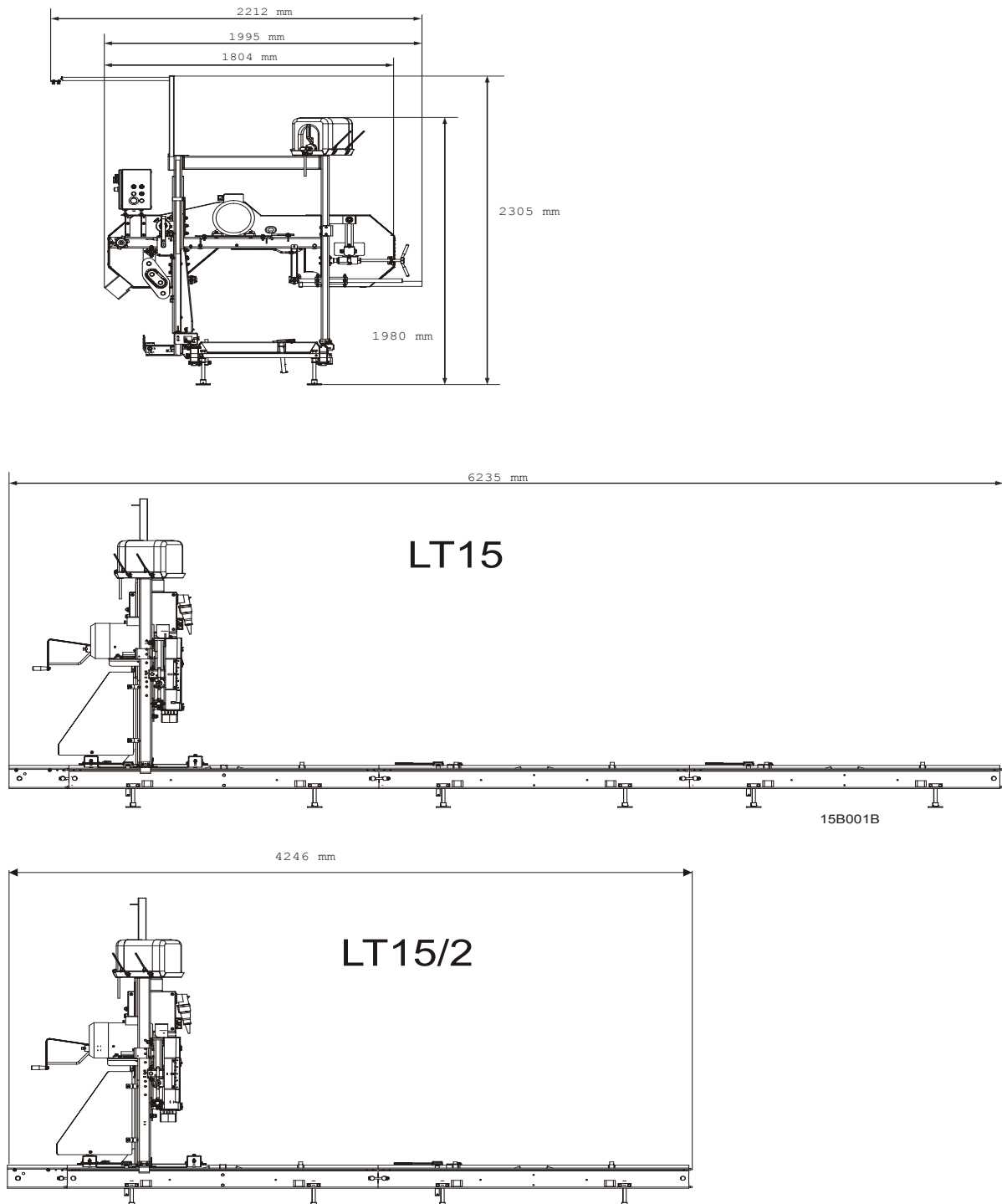
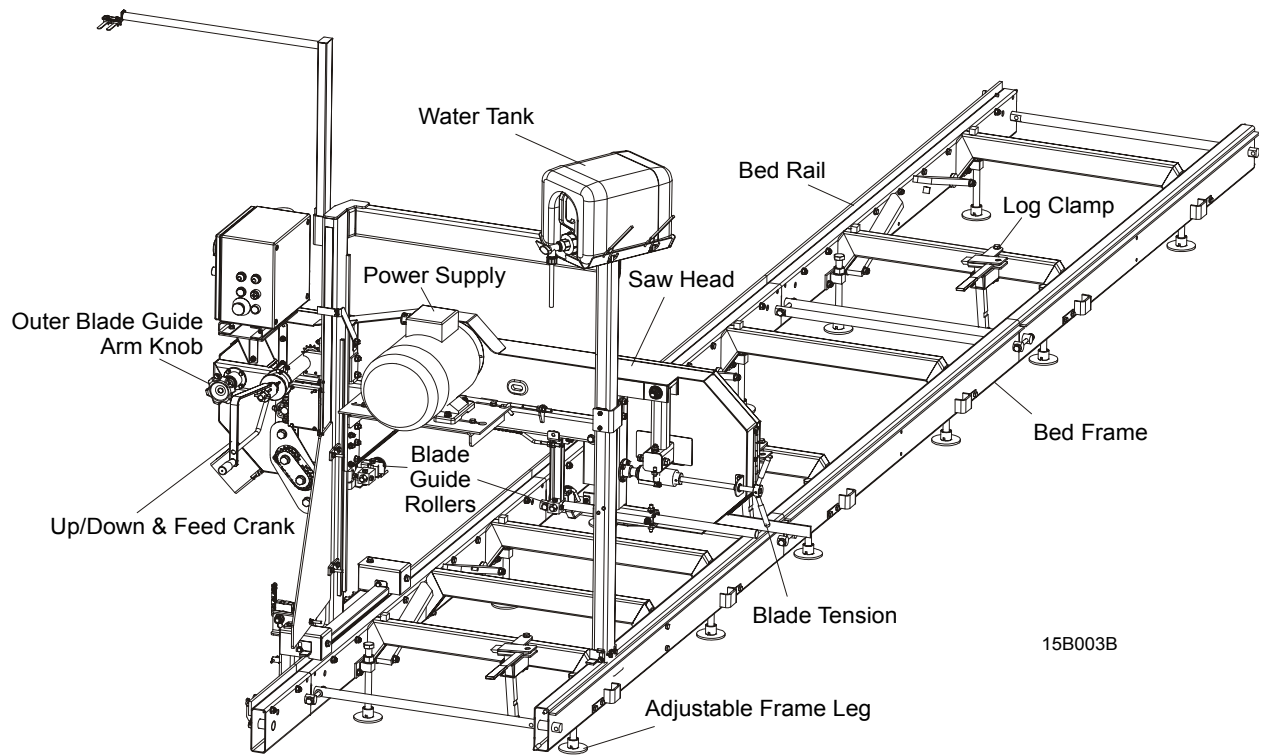

FIG. 1-1

## 1.10 Components

See Figure 1-2. The major components of the Wood-Mizer LT15 are shown below.



**FIG. 1-2**



### 1.11 Electrical Information

See Figure 1-3. The electrical symbol diagram of the LT15 equipped with the E11 electric motor is shown below.

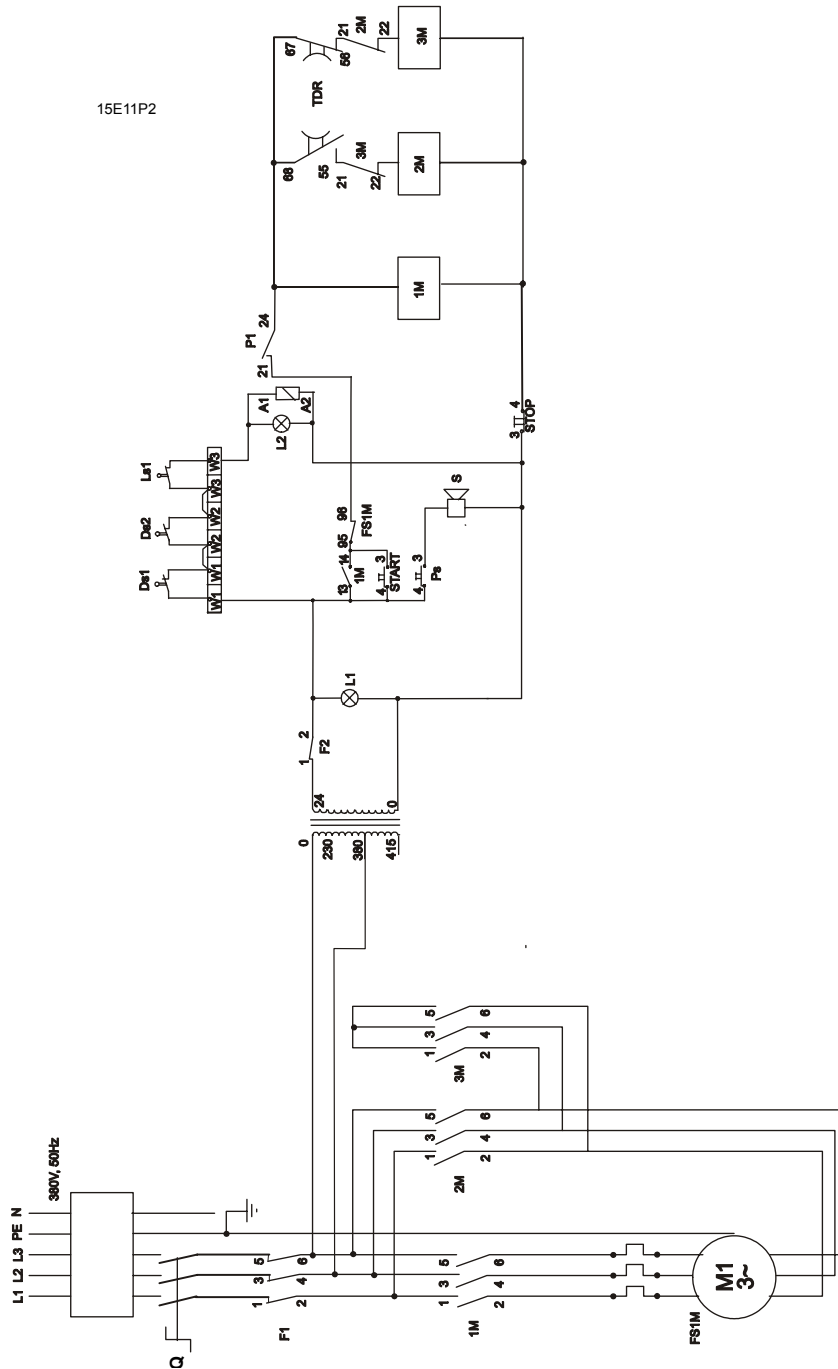

FIG. 1-3

**Limit Switches:** DS1 and DS2 - located on the blade guards, LS1 - activated by the hand grip

# 1

## Safety & General Information

### Electrical Information

See Table 1-6. The electrical component list is listed below

ID	Mfg. Part No.	Manufacturer	Wood-Mizer Part #	Description
F1	GZ1 M21	SCHNEIDER	--	Switch, Motor On/Off
F2	C60N 24395	SCHNEIDER	--	Switch
Q	ABB OT32E3	ABB	--	Disconnecter
TR	TMA 63 240/380/415-24V	EFA	--	Transformer, 240/380/415-24V
1M	LC1 D0901	SCHNEIDER	084305	Contactore
2M	LC1 D1801	SCHNEIDER	084306	Contactore
3M	LC1 D1810	SCHNEIDER	084307	Contactore
TDR	LR2DS2	SCHNEIDER	--	Relay, Time

TABLE 1-7

See Figure 1-4. The electrical symbol diagram of the LT15 equipped with the G13 gas engine is shown below.

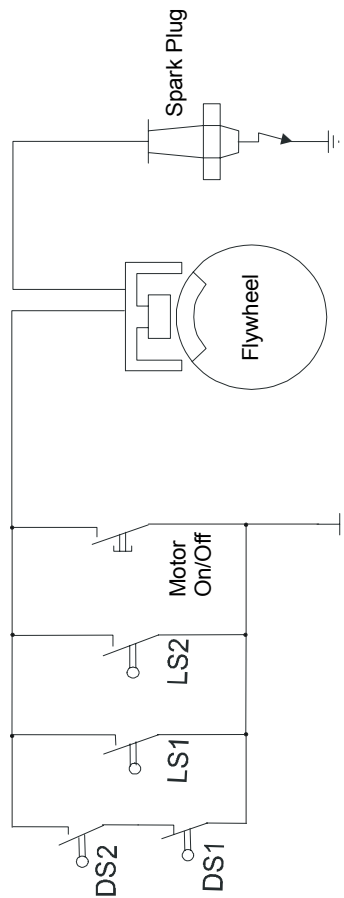

15G13P

LS1, LS2 - Limit Switches located on the blade guards  
 DS1 - Limit Switch activated by the left hand grip  
 DS2 - Limit Switch activated by the clutch/brake handle

FIG. 1-4

## SECTION 2 SAWMILL ASSEMBLY

### 2.1 Frame Assembly

1. Bolt four leg brackets to each bed section. Use two hex head bolts and lock nuts to secure each leg bracket to the bed section. Be sure the nut on the bracket faces up. Thread a leg into each bracket.

See Figure 2-1.

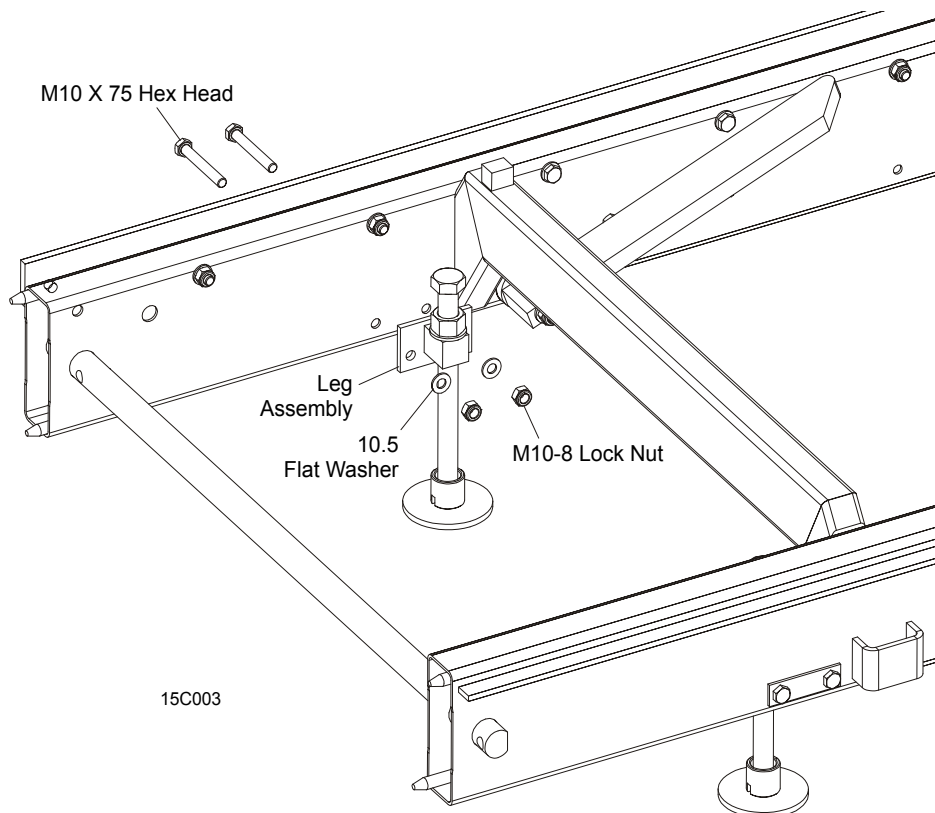

**FIG. 2-1**

## 2 Sawmill Assembly

### Frame Assembly

2. Lay the frame sections end-to-end so the track portion of each section is on the same side. Slide the sections together and secure with four hex head bolts and nylon lock nuts.

See Figure 2-2.

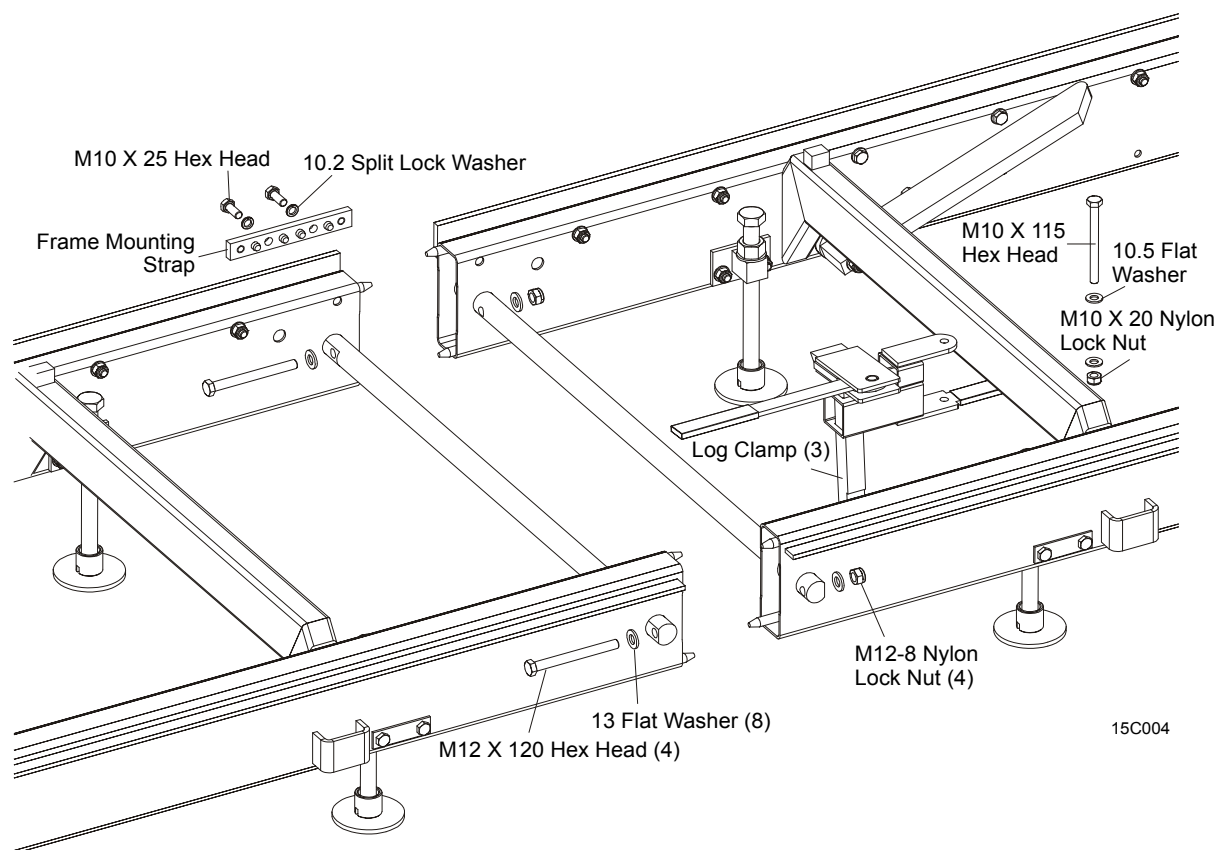

FIG. 2-2

3. Place the frame mounting strap in the recessed area across the track sections and secure with two hex head bolts. **NOTE:** It may be necessary to loosen the end bolts on each track rail to align the recessed areas so the mounting strap fits properly.
4. Assemble a log clamp to a bed rail on each bed section using a 3/8-16 x 4" hex head bolt and nylon lock nut.

## 2.2 Frame Leg Adjustment

1. Place a foot plate under each bed leg.
2. Use the leg wrench to adjust each leg until the nut is approximately 1 inch below the top of the bed tube.

See Figure 2-3.

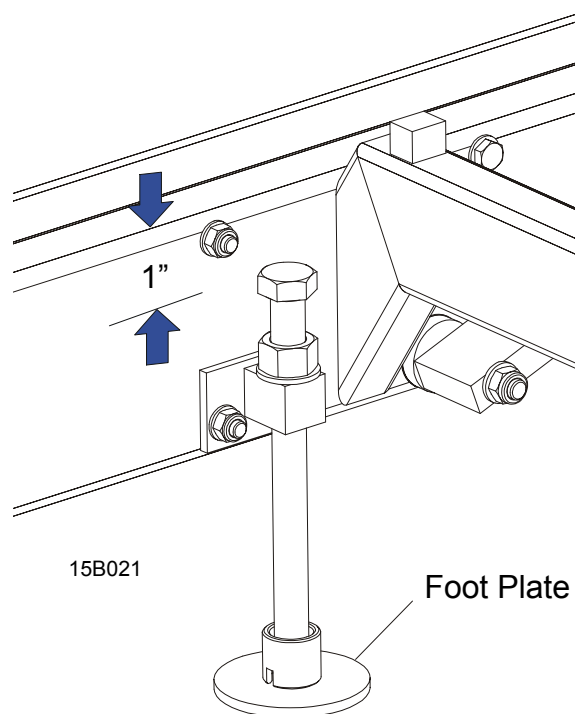
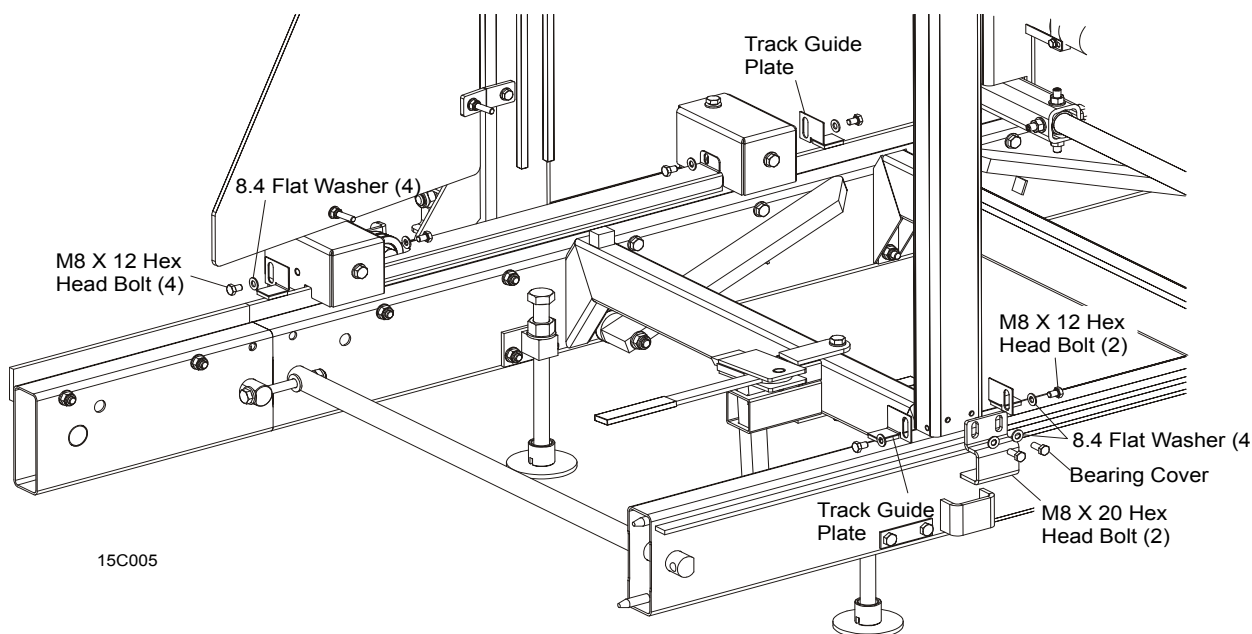

FIG. 2-3

## 2.3 Saw Carriage Assembly

1. Position the saw head carriage at the end of the bed frame assembly. Carefully slide the saw head carriage rollers onto the bed frame track. Keep the carriage square to the bed to avoid putting the track rollers in a bind.
2. Position the middle track cover between the two track roller housings so the opening in the cover is positioned over the feed rope pulleys. Secure with two hex head bolts and lock washers.
3. Install two slotted track scrapers to the track roller housings with a flat washer, lock washer, and hex head bolt each.

See Figure 2-4.



**FIG. 2-4**

4. Assemble the retaining bracket to the idle side upright with two hex head bolts and lock washers.
5. Assemble two track scrapers to the idle side upright with a hex head bolt, two flat washers, and a nylon lock nut.

## 2.4 Feed Rope Assembly

1. Install a feed rope mounting bracket at each end of the bed assembly using a hex head bolt and nylon lock nut. Be sure to use the brackets so they are angled toward the end of the frames as shown.

See Figure 2-5.

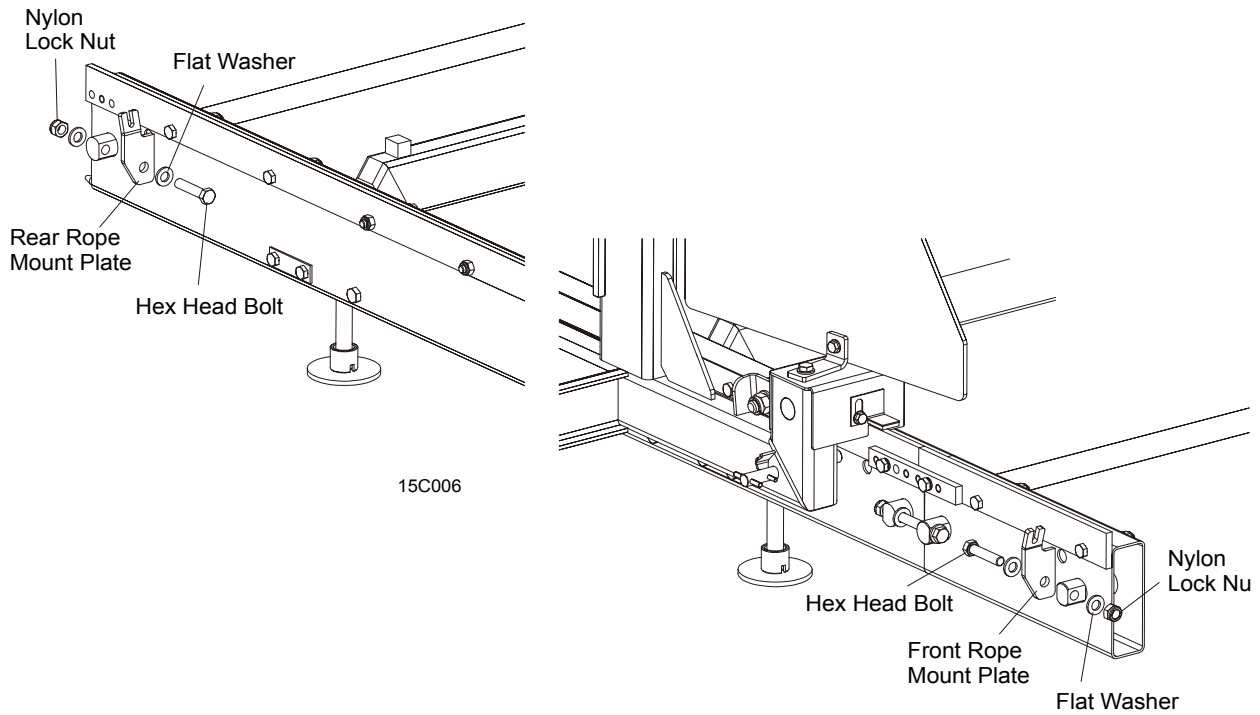

FIG. 2-5

## 2 Sawmill Assembly

### Feed Rope Assembly

2. Tie a knot in one end of the feed rope. Slip the knotted end of the rope into the front rope mount plate. Route the rope between the saw head carriage and bed frame tube.

See Figure 2-6.

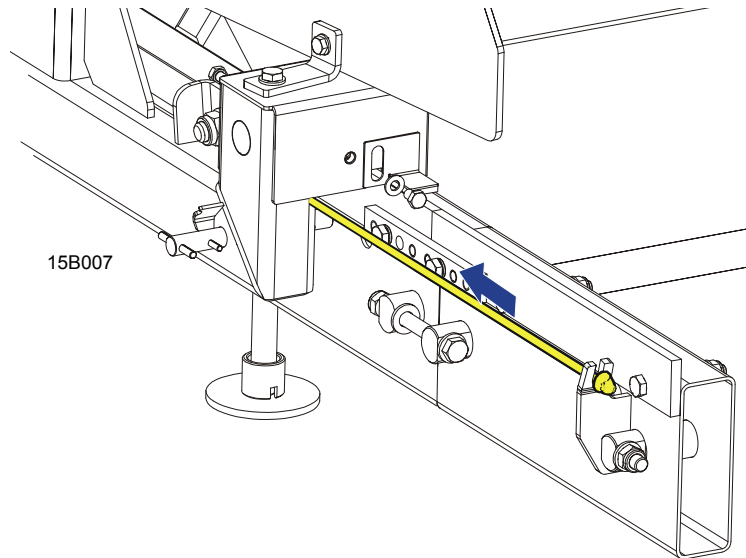

FIG. 2-6

3. Loop the rope around the inner groove of the lower feed pulley and route to the feed crank handle.

See Figure 2-7.

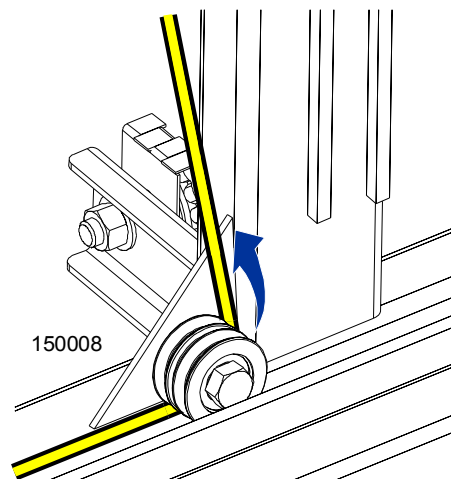

FIG. 2-7



4. Loop the rope around the feed crank spool three times and route back down to the lower feed pulley.

See Figure 2-8.

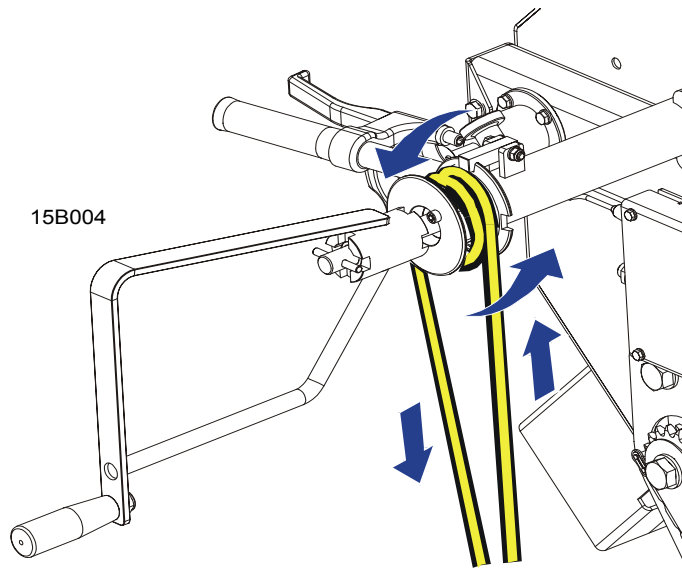

FIG. 2-8

5. Route the rope around the outer groove of the lower feed pulley.

See Figure 2-9.

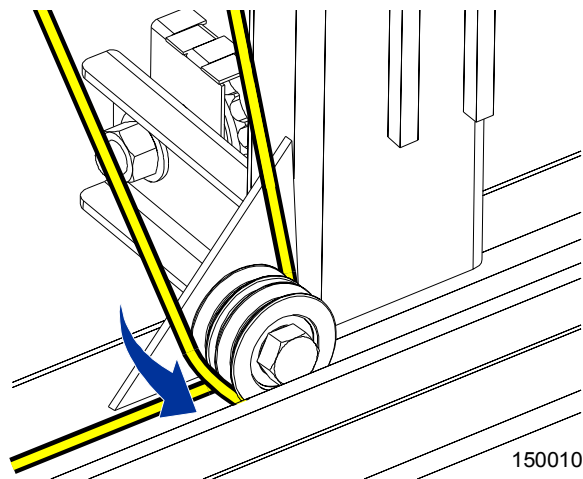

FIG. 2-9

## 2 Sawmill Assembly

### Feed Rope Assembly

---

6. Route the rope to the rear mounting bracket. Tie a knot in the end of the rope and insert into the mounting bracket. Position the knot in the rope so when installed to the rear bracket, the rope is tight.

See Figure 2-10.

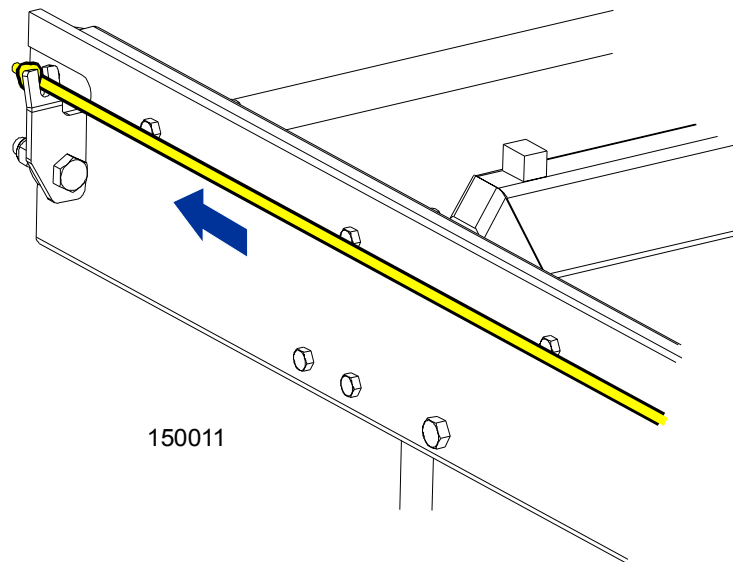

**FIG. 2-10**

## 2.5 Engine Assembly

1. Place the engine assembly in place on the saw head. Align the holes in the engine mount plate with the engine mounting bolts. Do not tighten the bolts until the drive belt is installed and properly tensioned. Hook the belt tension turnbuckle into the hole on the engine mount plate.

See Figure 2-11.

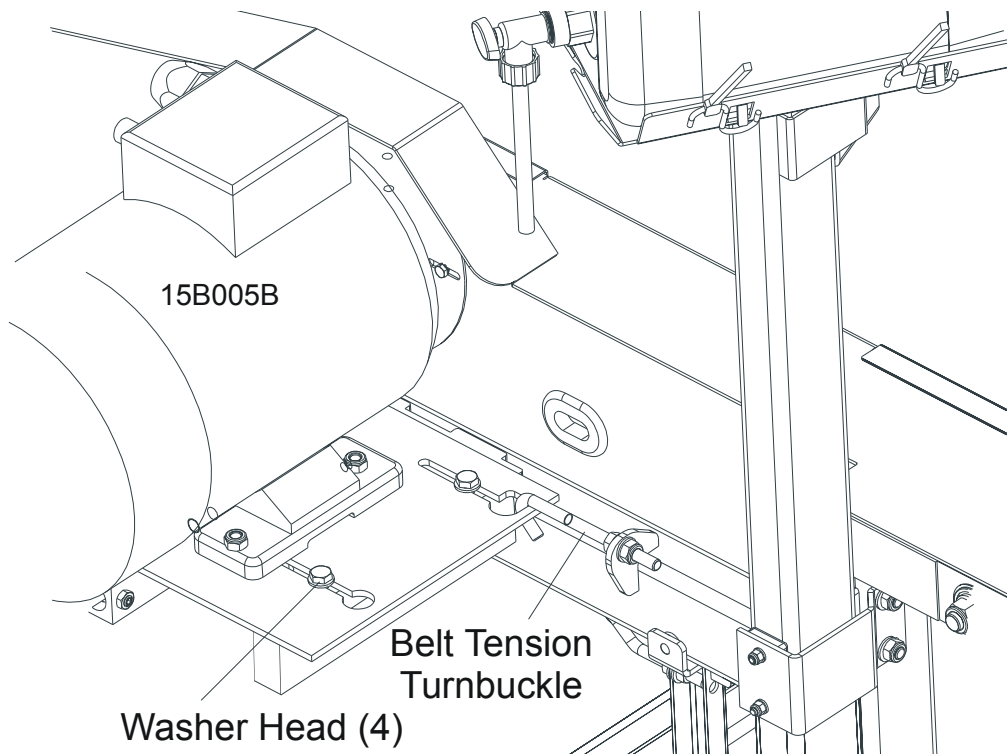

FIG. 2-11

2. Open the drive-side blade pulley housing and install the drive belt around the engine pulley and the inner groove of the drive-side blade pulley.
3. Adjust the jam nuts on the belt tension turnbuckle to move the engine out, tightening the drive belt. Adjust until the belt has approximately 1/2" deflection. Tighten the four engine mounting bolts.

## 2 Sawmill Assembly

*Engine Assembly*

---

See Figure 2-12. Tighten the screws with the torque as shown on the figure below.

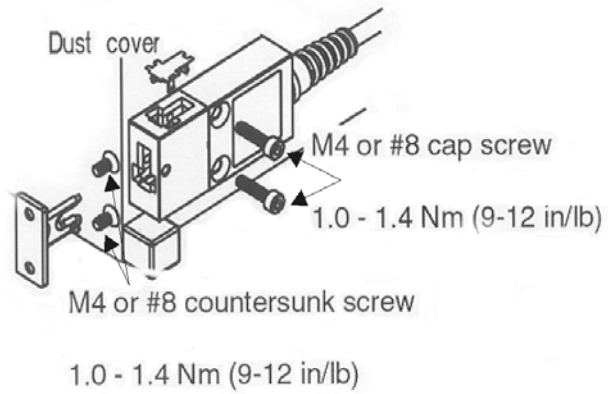

**FIG. 2-12**

## 2.6 Auxiliary Bed Rail

Install the auxiliary bed rail to the front bed frame section. A set of mounting holes is provided between the two bed rails. Remove the existing bolt and lock nut that secures the track at this position. Use three hex head bolts and lock nuts to secure the bed rail to the bed section. Replace the existing bolt and lock nut.

See Figure 2-13.

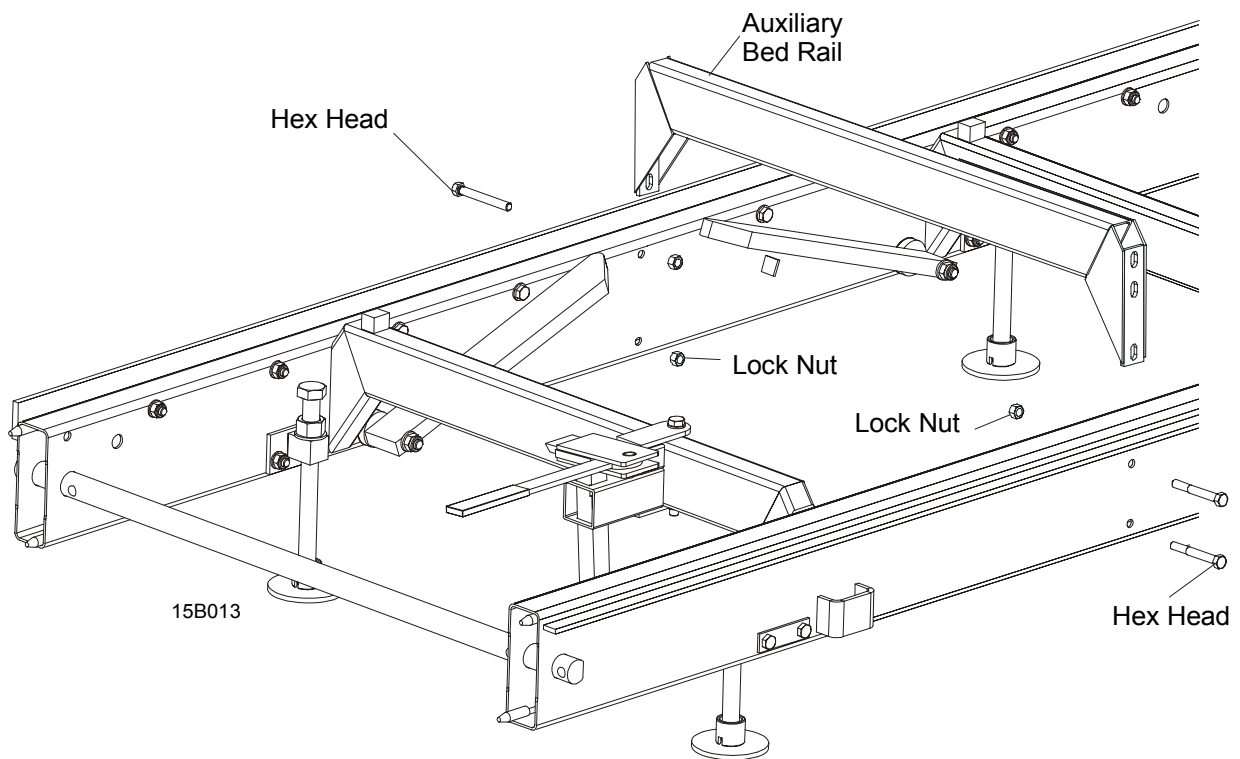

FIG. 2-13

**2** **Sawmill Assembly**  
*Auxiliary Bed Rail*

---

## SECTION 3 SETUP & OPERATION

### 3.1 Sawmill Setup

**NOTE:** The following setup procedure should be performed whenever the sawmill is moved or reassembled. If sawing problems occur and misalignment is suspected, [See SECTION 6](#) for complete alignment instructions.

1. Adjust the frame legs so the sawmill appears level. If sawmill is on soft ground, use shims under the legs if necessary.
2. Run a string from the front bed rail to the rear bed rail near the operator's side of the frame. Place identical spacers between the string and the front and rear bed rails. Measure the distance between the string and the other bed rails. Adjust the frame legs until all bed rails measure the same distance from the string.
3. Loosen the auxiliary bed rail bolts and adjust the rail so it is the same distance from the string as the main bed rails. Retighten the bolts.

See Figure 3-1.

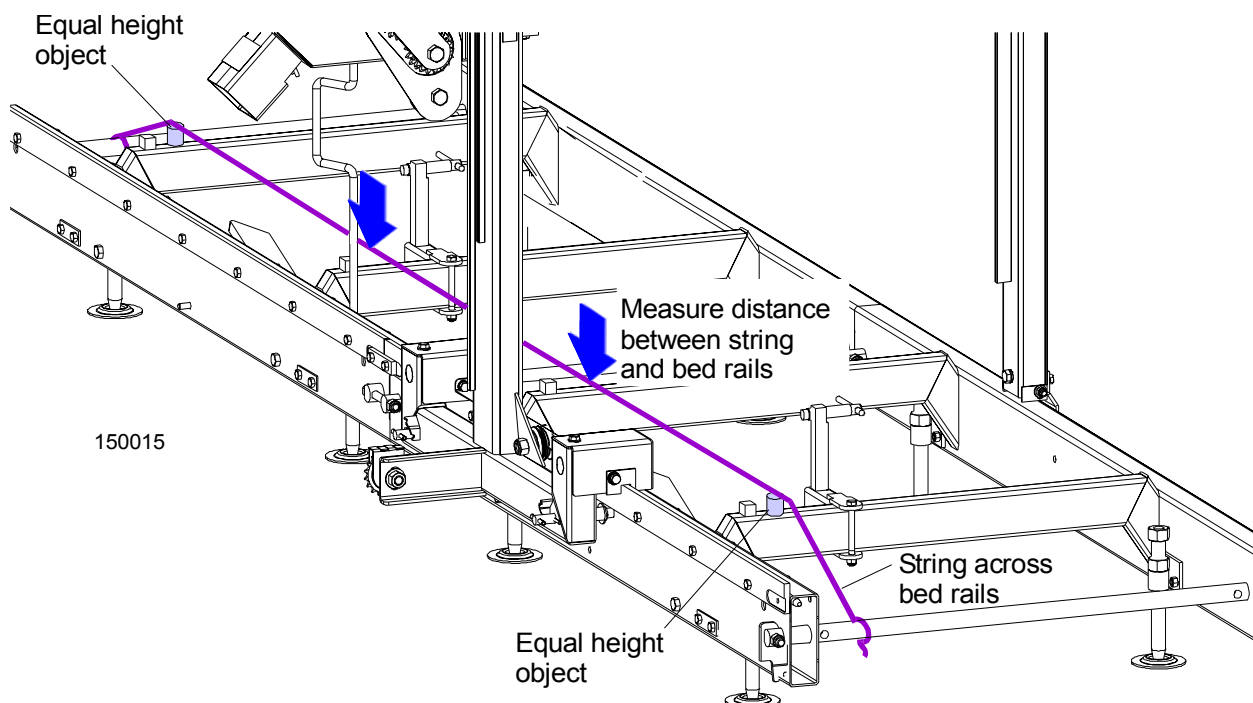

FIG. 3-1

# 3

## Setup & Operation

### Sawmill Setup

4. Repeat the bed rail adjustment with the string at the other side of the sawmill frame.
5. Install a blade ([See Section 3.2](#) through [Section 3.4](#)) and move the saw carriage until the blade is positioned over the front bed rail.
6. Measure the distance from the bed rail to the bottom of the blade near the inside blade guide.
7. Measure the distance from the bed rail to the bottom of the blade near the outside blade guide.

**See Figure 3-2.** When the blade is parallel to the bed, it will measure the same distance from the bed rail at the inside and outside of the saw head. Use the saw head adjustment nuts to move the outside of the saw head up or down. Loosen the four top nuts and tighten the four bottom nuts in 1/4-turn increments to raise the outside of the saw head. Loosen the bottom nuts and tighten the top nuts in 1/4-turn increments to lower the outside of the saw head.

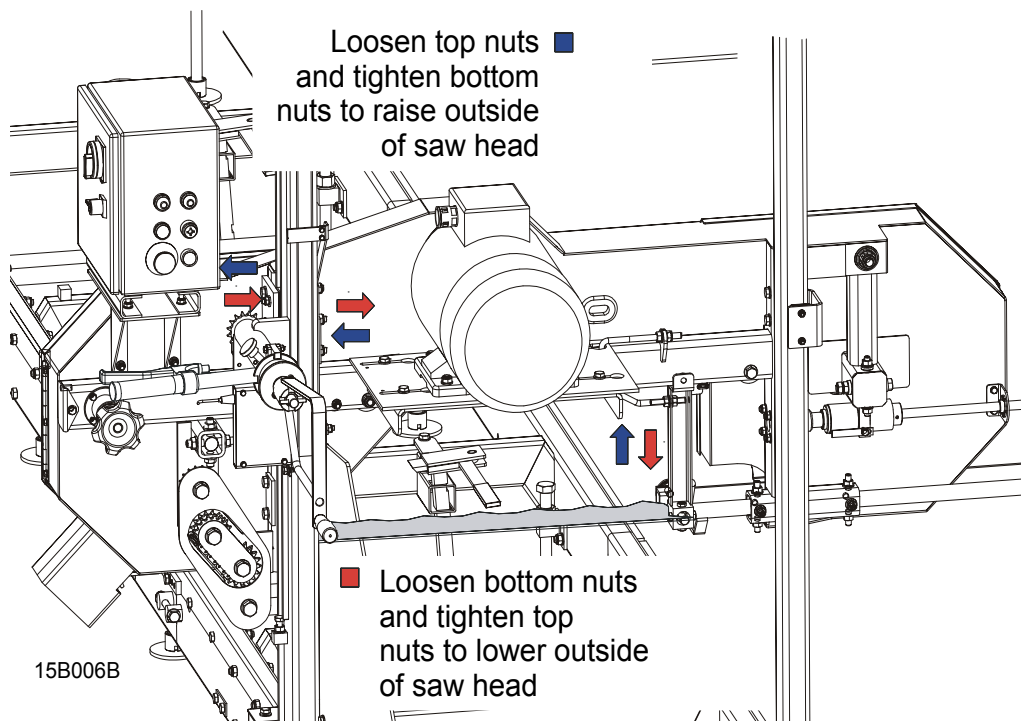

**FIG. 3-2**



## 3.2 Replacing The Blade



**DANGER!** Always disengage the blade and shut off the sawmill engine before changing the blade. Failure to do so will result in serious injury.



**WARNING!** Always wear gloves and eye protection when handling bandsaw blades. Changing blades is safest when done by one person! Keep all other persons away from area when coiling, carrying or changing a blade. Failure to do so may result in serious injury.

Adjust the blade guide arm all the way open.

Open the two blade housing covers that cover the blade wheels. Turn the blade tension handle to release the blade tension until the wheel is pulled in and the blade is lying loose in the blade housing. Lift the blade out of the blade housing.

When installing a blade, make sure the teeth are pointing the correct direction. The teeth should be pointing toward the operator side of the mill when you are looking at the blade below the blade guides. Install the blade so it is lying around the wheels.

Position 1 1/4" wide blades on the wheels so the gullet is 1/8" (3.0 mm) out from the edge of the wheel. Position 1 1/2" wide blades on the wheels so the gullet is 3/16" (4.5 mm) out from the edge of the wheel.

Close the blade housing covers.

Next, turn the tension handle until the blade is tensioned correctly.

### 3.3 Tensioning The Blade

See **Figure 3-3**. Turn the blade tension handle clockwise to compress the rubber spring and tension the blade. Check the blade tension occasionally when adjusting the cant control or while cutting. As the blade and belts heat up and stretch, the blade tension will change. Adjust the tension handle as necessary to keep the bushing aligned with the indicator.

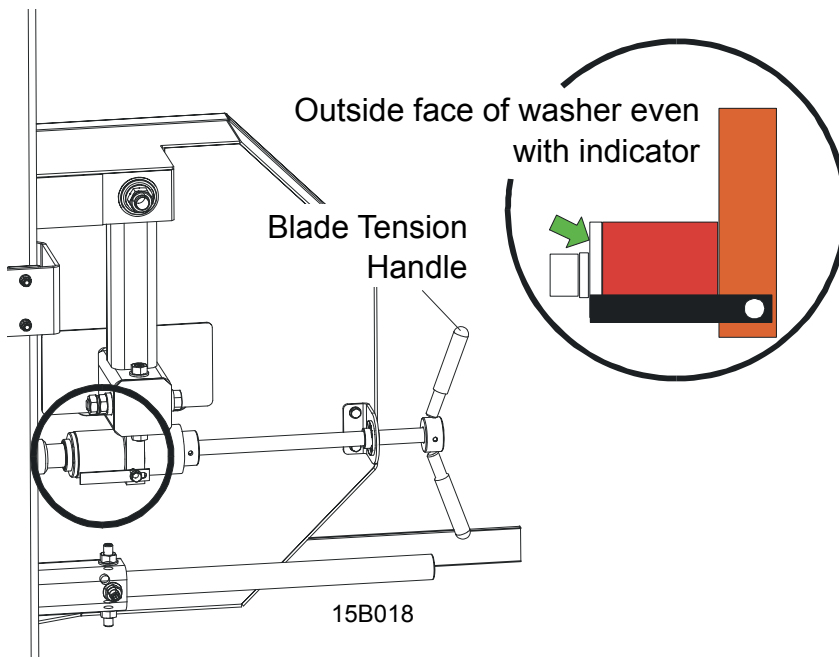

**FIG. 3-3**

### 3.4 Tracking The Blade

1. Make sure the blade housing covers are closed and all persons are clear of the blade.
2. Start the engine (or motor).
3. Pull lightly on the clutch handle, rotating the blade until the blade positions itself on the wheels.



**WARNING!** Do not spin the blade wheels by hand. Spinning the blade wheels by hand may result in serious injury.

4. Release the clutch handle to stop the blade. Turn off the engine and check the position of the blade on the blade wheels.

See **Figure 3-4**. Position 1 1/4" wide blades so the gullet is 1/8" (3.0 mm) out from the edge of the blade wheel ( $\pm 1/32$  [.75 mm]).

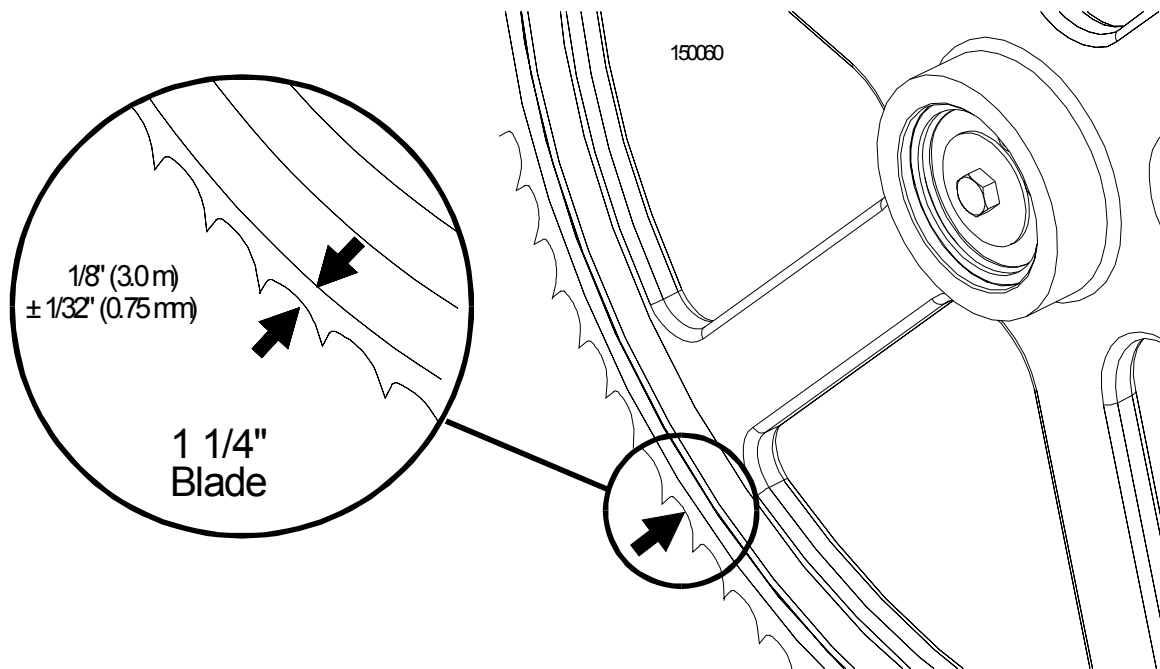
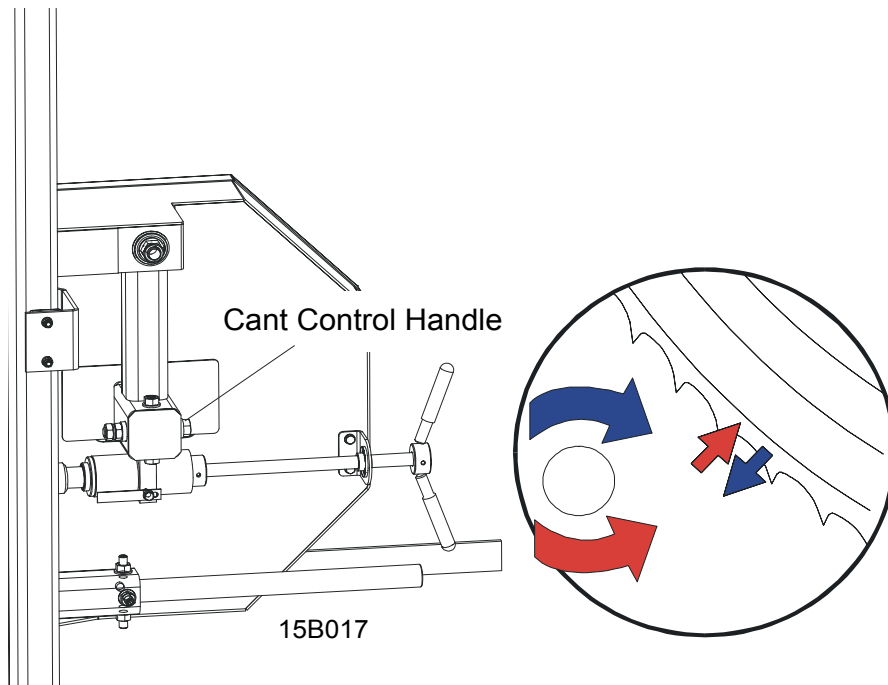

FIG. 3-4

See **Figure 3-5**. To adjust where the blade travels on the blade wheels, use the cant control handle.



**FIG. 3-5**

If the blade is too far out, back the blade onto the wheel by turning the cant control counterclockwise. If the blade is too far in, turn the cant control clockwise until the gullet of the blade is the correct distance from the front edge of the wheel.

5. Adjust the blade tension if necessary to compensate for any changes that may have occurred while adjusting the cant control.
6. Close the blade housing covers.



**DANGER!** Make sure all guards and covers are in place and secured before operating the sawmill. Failure to do so may result in serious injury. Be sure the blade housing and pulley covers are in place and secure.

**IMPORTANT!** After aligning the blade on the wheels, always double-check the blade guide spacing and location. ([See SECTION 6](#) for more information.)

### 3.5 Starting The Engine

See the appropriate manual supplied with your specific engine configuration for starting and operating instructions.



**DANGER!** Make sure all guards and covers are in place and secured before operating the sawmill. Failure to do so may result in serious injury. Be sure the blade housing and pulley covers are in place and secure.



**DANGER!** Always be sure the blade is disengaged and all persons are out of the path of the blade before starting the engine or motor. Failure to do so will result in serious injury.



**WARNING!** Always wear eye, ear, respiration, and foot protection when operating the sawmill. Failure to do so may result in serious injury.

## 3.6 Loading, Turning, And Clamping Logs

### To Load Logs

1. Move the saw carriage to the front end of the frame.

 **CAUTION!** Before loading a log, be sure the cutting head is moved far enough forward so the log does not hit it. Failure to do so may result in machine damage.

2. Adjust the log clamps all the way down and move them toward the loading side of the sawmill frame.

 **CAUTION!** Be sure the log clamps are all the way down before loading a log onto the bed. Failure to do so may result in machine damage.

3. Raise the side supports on the sawmill bed to prevent the log from falling off the side of the bed.
4. Place the optional loading ramps in the frame brackets that will evenly support the length of the log.

See Figure 3-6.

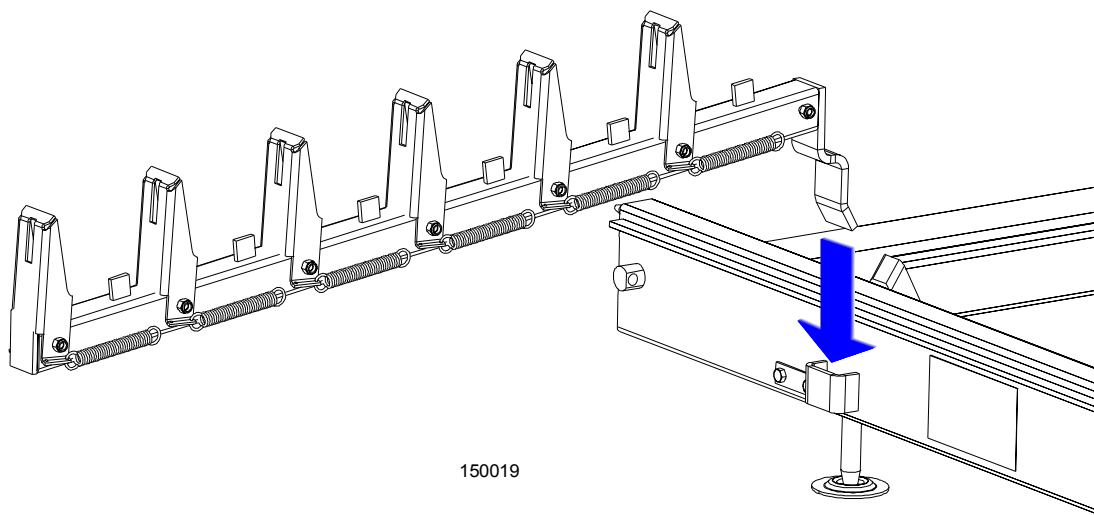

**FIG. 3-6**

5. Position the log at the foot of the ramps.
6. Use a cant hook to roll the log up the ramps and onto the sawmill bed. Position the log against the side supports.
7. Remove the log ramps and set aside.



**CAUTION!** The saw head will hit the spring-loaded ramp stops when adjusted for low cuts. Remove the loading ramps before sawing to prevent damage to the saw head and/or blade guide arm.

If you did not purchase the optional loading ramps, use boards for ramps or use log loading equipment to load the log on the sawmill bed.

#### **To Turn Logs**

1. Use a cant hook to spin the log against the side supports until it is turned the way you want it for the first cut.

**To Clamp Logs**

1. Position the clamps against the log, far enough down so they are below your first few cuts. Turn the clamp screws in so they move the log firmly against the side supports.

**See Figure 3-7.**

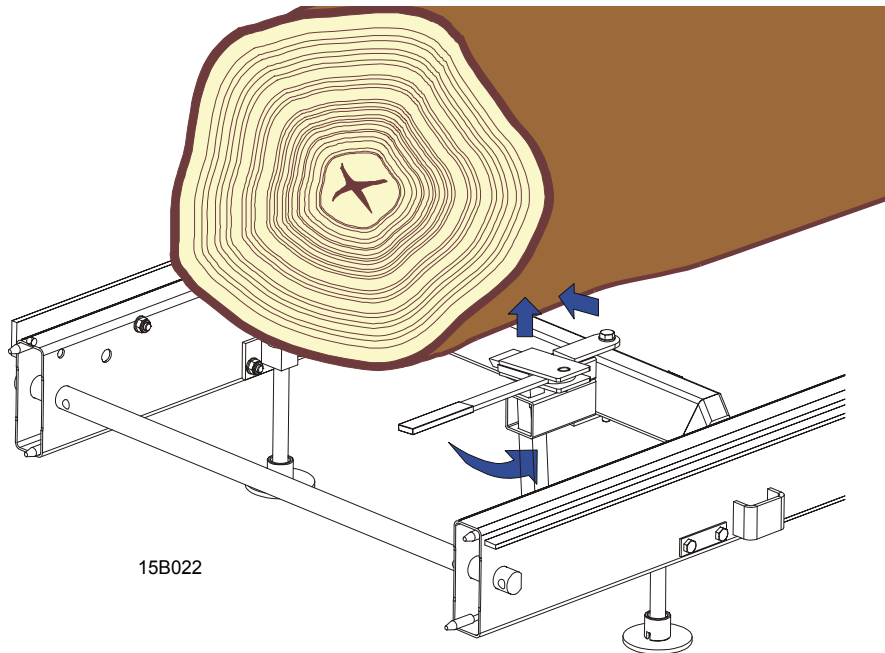

**FIG. 3-7**

2. Make sure the side supports are positioned low enough for the blade to pass over them. If they are not, back the clamps off slightly and push the side supports down until they are positioned below the level of your first few cuts.



### To Level A Tapered Log

Use shims or the optional wedge to raise either end of a tapered log, if desired.

Shim one end of the log until the heart of the log measures the same distance from the bed rails at each end of the log.

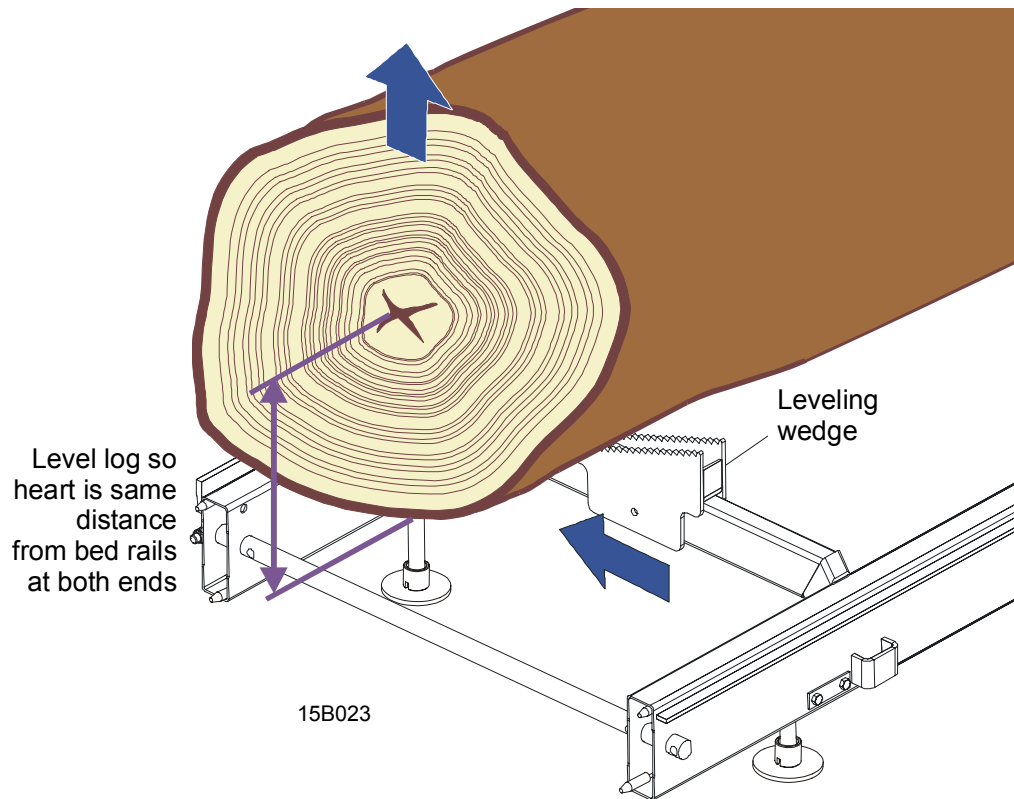

**FIG. 3-7**

### 3.7 Up/Down Operation

1. Install a blade, if needed, and check for correct blade tension. ([See Section 3.3](#)).

Set the cutting head to the desired height. (The blade height scale shows the height of the blade above the bed rails.)

**See Figure 3-8.** Use the up/down crank to raise or lower the cutting head.

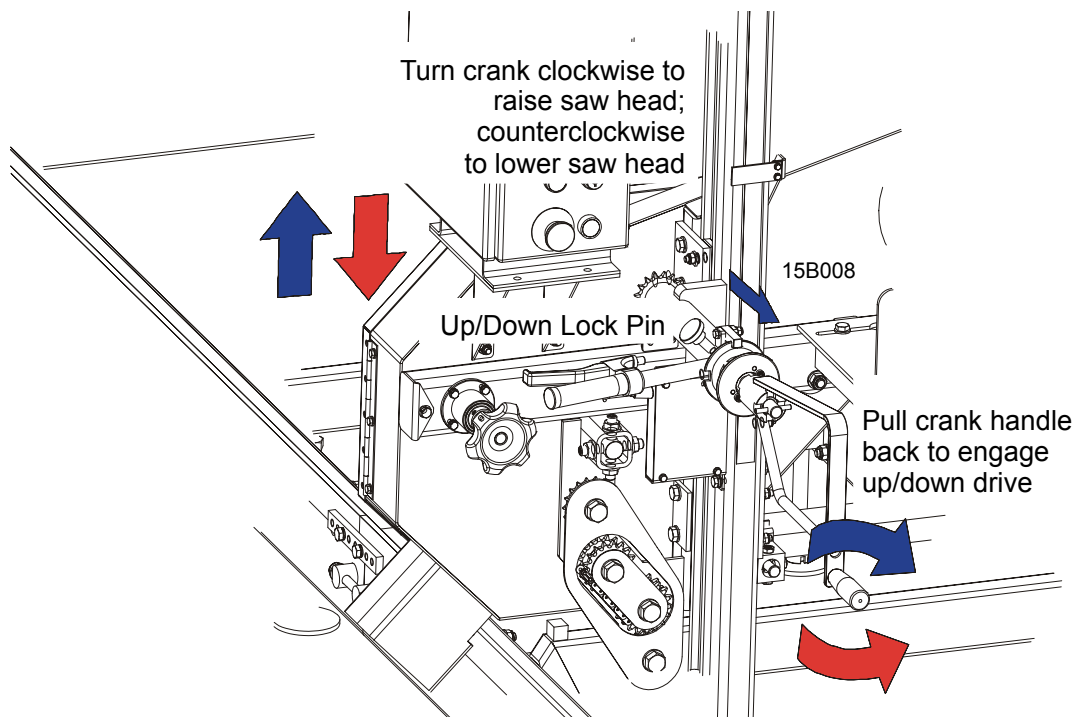

**FIG. 3-8**

2. Turn the up/down lock counterclockwise until it disengages the up/down shaft.
3. Pull back on the crank handle to engage the locking pins for up/down operation.
4. Turn the up/down crank clockwise to raise the saw head, counterclockwise to lower the saw head.
5. Turn the up/down lock clockwise until it engages the up/down shaft.

**CAUTION!** DO NOT try to force the carriage above the 27" (68 cm) mark or below the 1" (2.54 cm) mark. Damage to the up/down system may result.

### 3.8 Blade Guide Arm Operation

1. Look down the length of the log to see its maximum width. The outer blade guide should be adjusted to clear the widest section of the log by less than 1" (25.4 mm).
2. Use the blade guide arm knob to adjust the outer blade guide as necessary. Turn the blade guide arm knob clockwise to move the arm in. Turn the knob counterclockwise to move the arm out.

See Figure 3-9.

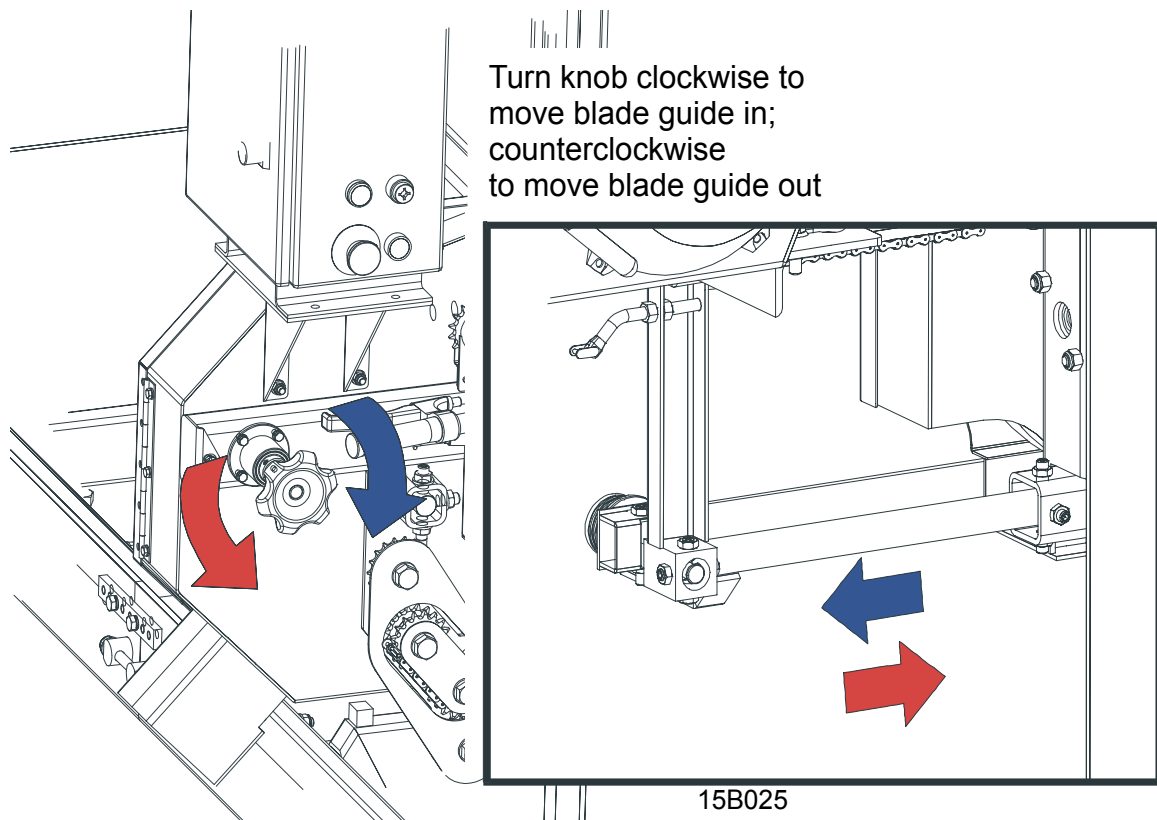

FIG. 3-9

### 3.9 Blade Drive Operation



**DANGER!** Make sure all guards and covers are in place and secured before operating the sawmill. Failure to do so may result in serious injury. Be sure the blade housing and pulley covers are in place and secure.

Be sure the blade housing and pulley covers are in place and secure before starting the engine or motor. Use the rubber latches to fasten blade housing covers shut. If the blade housing covers are not closed and secured the safety shut-off switches interrupt the ignition (the contactor) circuit and the engine motor can not be started. If the cover is opened during the mill operation the engine/motor will be stopped.

#### Electric motor only

1. Clear any loose objects from the area of the blade, motor, and drive belt.
2. Make sure the clamps and side supports are adjusted below the level of your first few cuts.
3. Start the motor as instructed in the motor manual.

See Figure 3-10.

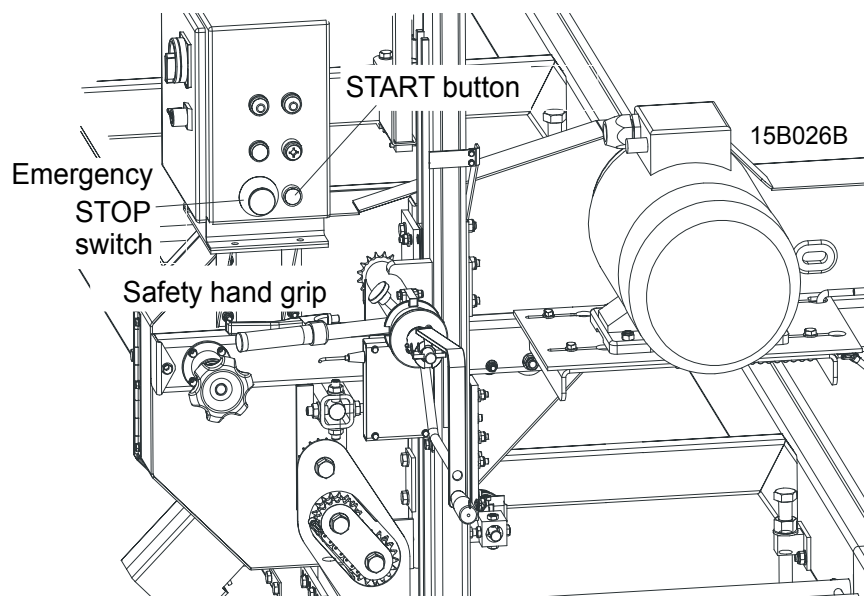

FIG. 3-10

4. To engage the blade, press the safety grip with your left hand and hold it down. Then press the START button located on the electric control box. This starts the motor engaged with the drive mechanism. Keep the safety grip pressed all the time the blade is driven in order to prevent the sawmill operator from getting to the path of the blade. If the safety grip is released the motor stops and it needs to be restarted.

#### Gas engine only

1. Clear any loose objects from the area of the blade, motor, and drive belt.
2. Make sure the clamps and side supports are adjusted below the level of your first few cuts.
3. Start the engine as instructed in the engine manual.

See **Figure 3-11**. The tensioner handle is located next to the engine.

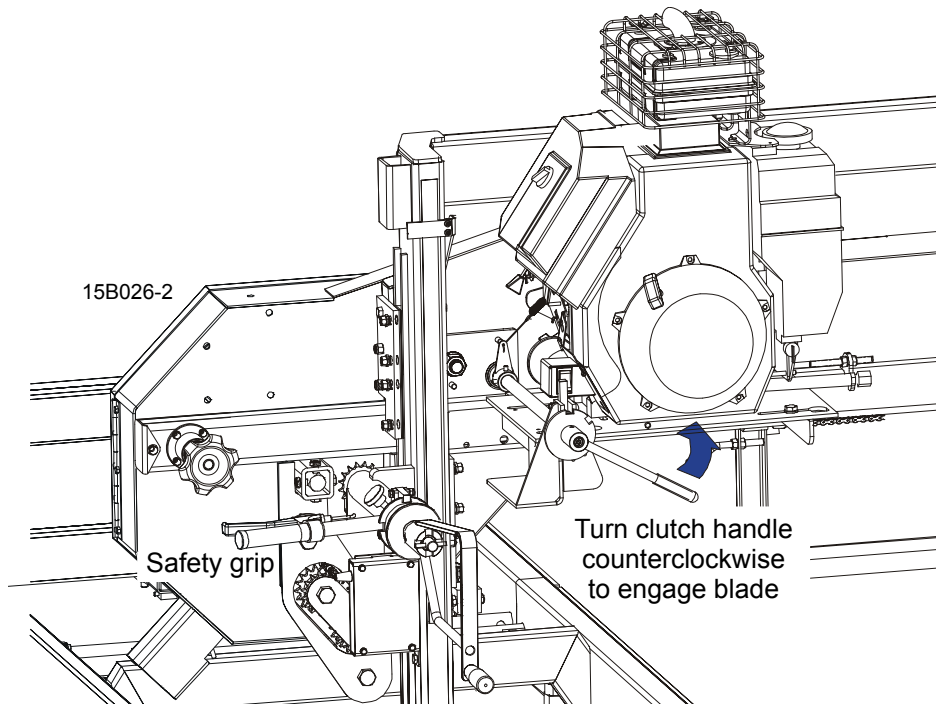

**FIG. 3-11**

# 3

## Setup & Operation

### *Blade Drive Operation*

---

4. To engage the blade, press the safety grip with your left hand and hold it down. Then turn the tensioner handle counterclockwise until it locks in the up position. This engages the drive mechanism and increases the engine speed to full throttle. Keep the safety grip pressed all the time the tensioner is engaged and the blade is driven in order to prevent the sawmill operator from getting to the path of the blade. If the safety grip is released the engine stops and it needs to be restarted.
5. To disengage the blade, turn the tensioner handle to the down position. This disengages the drive belt and returns the engine to idle. The safety grip can be released now, the engine continues to run idle.

### 3.10 Feed Operation

The feed system includes a hand crank to move the carriage forward or backward. The speed at which the carriage travels forward depends on how fast you turn the feed crank.

1. To move the carriage forward, push the crank handle in to engage the screw heads and rotate the feed crank clockwise.

See Figure 3-12.

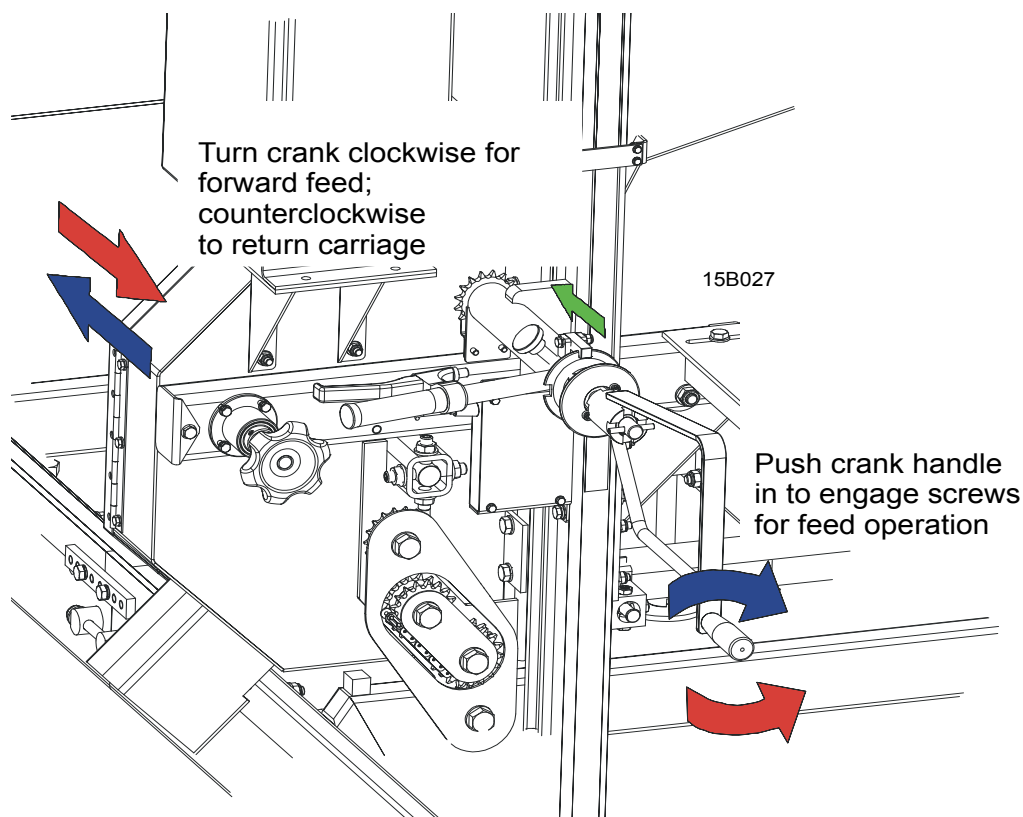

FIG. 3-12

**HINT:** To get a straight cut in the first part of the board, feed the blade into the log at a slow speed. This stops the blade from flexing and dipping up or down. Use a slow speed until the whole width of the blade has entered the cut. Then increase the feed rate as desired. Maximum feed rate varies with width and hardness of the wood. Over-feeding results in engine and blade wear, and also produces a wavy cut.

2. To move the carriage backward, rotate the feed crank counterclockwise, or pull the saw head back. Always disengage the blade before returning the carriage and raise the carriage slightly to make sure the blade clears the log.



**CAUTION!** Be sure to stop the blade when returning the carriage. This will not only prevent the blade from being pulled off and ruined by a wood sliver, but also will increase the life of the blade.

3. Make sure that the blade does not catch on the end of the log. Raise the carriage slightly to make sure the blade clears the log when returned.

**HINT:** Try to stop the blade while the heel of the blade is still on the log. Then bring the carriage back without adjusting the blade up. This lets you keep the blade at the current height setting so you can make the next blade height adjustment more quickly.

### 3.11 Cutting The Log

The following steps guide you through normal operation of the Wood-Mizer sawmill.

1. Once the log is placed where you want it and clamped firmly, position the blade close to the end of the log.
2. Use the blade height scale to determine where to make your first cut ([See Section 3.13](#)). The blade height scale will help you to do this. Set the blade to the desired height with the up/down crank. Make sure that the blade will clear all side supports and the clamp. Adjust the outer blade guide to clear the widest section of the log by moving the blade guide arm knob.
3. Make sure all covers and guards are in place. Start the engine. Engage the clutch lever to start the blade spinning.
4. Start the water lube if necessary to prevent sap buildup on the blade. [See Section 3.14](#).
5. Feed the blade into the log slowly ([See Section 3.10](#)). Once the blade completely enters the log, increase the feed rate as desired. Always try to cut at the fastest speed you can while keeping an accurate cut. Cutting too slowly will waste blade life and lower production!
6. As you get to the end of the log, slow down the feed rate. When the teeth exit the end of the log, disengage the clutch/brake lever. Remove the slab that you have just cut from the log.
7. Use the feed crank to return the carriage to the front of the mill. Always disengage the blade before returning the carriage for the next cut.
8. Repeat until the first side of the log is cut as desired. Set aside the usable flitches (boards with bark on one or both sides). You can edge them on the mill later.



9. Remove the wedge if it was used. Remove the clamps and turn the log 90 or 180 degrees. Make sure the flat on the log is placed flat against side supports if turned 90 degrees. Make sure it is placed on bed rails if turned 180 degrees. If the log was turned 90 degrees and you are using the wedge to compensate for taper in the log, use the wedge again to adjust the heart of the log parallel with the bed.
10. Repeat the steps used to cut the first side of the log until the log is square. Cut boards from the remaining cant by adjusting the blade height for the thickness of boards that you want.

**Example:** Remember that the blade cuts a 1/16 - 1/8" (1.6-3.2 mm) wide kerf. If you want 1" (25.4 mm) thick boards, lower the carriage 1 1/16 - 1 1/8" (27-28.6 mm) for each board.

### 3.12 Edging

The following steps guide you through edging boards on the Wood-Mizer sawmill.

1. Raise the side supports to 1/2 the height of the flitches, or the boards that need to be edged.
2. Stack the flitches on edge against the side supports.
3. Clamp the flitches against the side supports halfway up the flitch height. (Wider flitches should be placed to the clamp side. When they are edged, flip them over to edge the second side without disturbing the other flitches or without having to pull them from the middle of the stack).
4. Adjust the blade height to edge a few of the widest boards.
5. Loosen the clamps and turn the edged boards over to edge the other side.
6. Repeat steps 2-4.
7. Loosen the clamps and remove the boards that have good clean edges on both sides. Clamp the remaining flitches and repeat steps 2-5.

### 3.13 Blade Height Scale

See Figure 3-13. The blade height scale is attached to the carriage head frame. It includes:

- a blade height indicator
- an inch scale

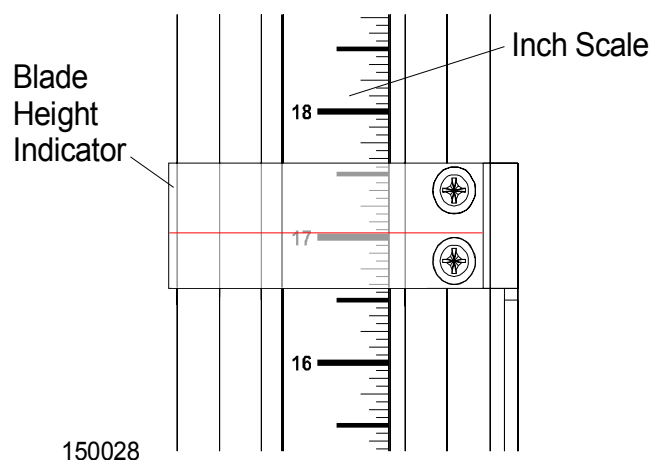

FIG. 3-13

#### The Inch Scale

The horizontal red line on the blade height indicator shows how many inches the bottom of the blade is above the bed of the mill. If you know the height of your blade at each cut, you can determine the thickness of lumber you are sawing.

**Example:** You want to cut 1" (25 mm) random width boards from a log. Position the blade for the first cut. Move the carriage to an even measurement on the inch scale. Make a trim cut. Return the carriage for the second cut and lower it 1 1/8" (29 mm) below the original measurement. (The extra 1/8" (3 mm) allows for saw kerf and shrinkage of the lumber.)

The yellow area on the scale identifies where the blade could encounter a side support or log clamp. Check that these items are below the blade level before sawing.

### 3.14 Water Lube Operation

The optional Water Lube System keeps the blade clean. Water flows from a 5-gallon (18.9 liter) bottle through a hose to the blade guide where the blade enters the log. A valve in the bottle cap controls the amount of water flow.

See **Figure 3-14**. Install the water bottle bracket at the top of the saw head mast.

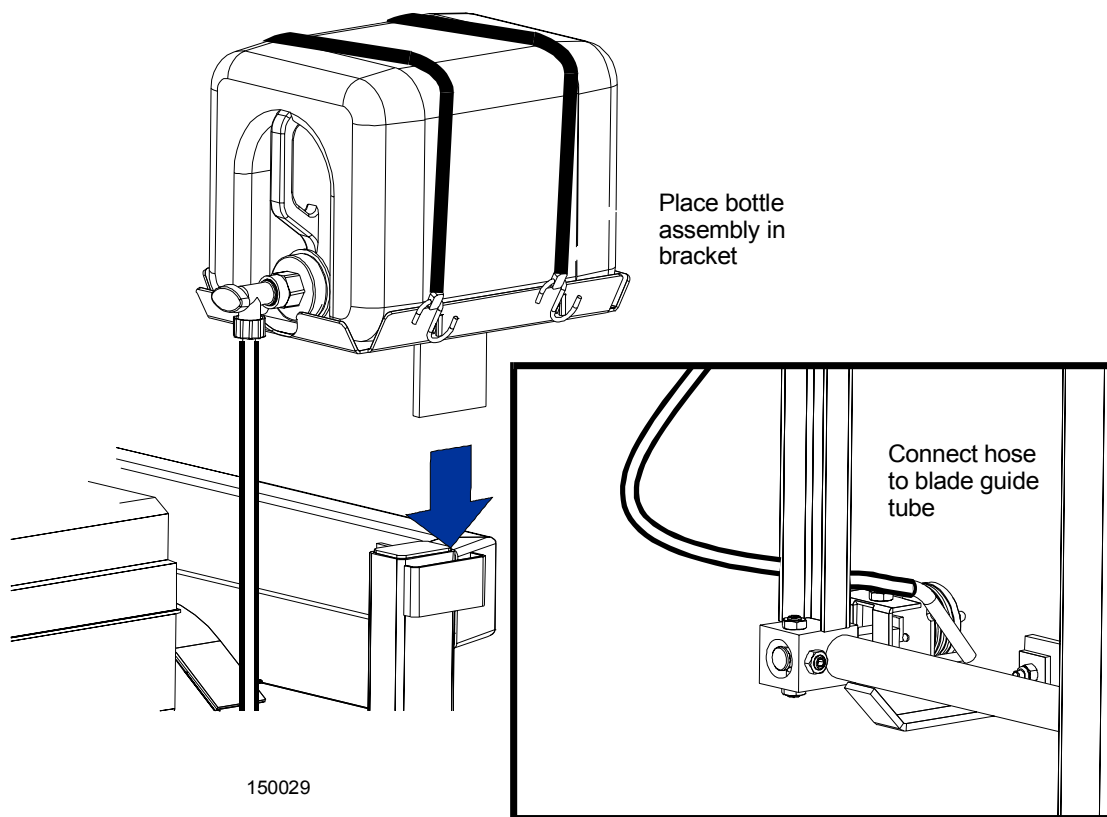

**FIG. 3-14**

See Figure 3-15. Open the valve on the water bottle to start water flow to the blade.

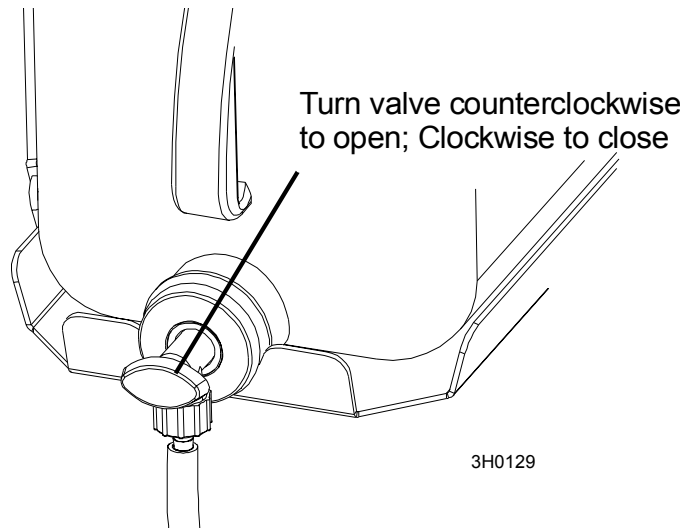

3H0129

FIG. 3-15

Not all types of wood require the use of the Water Lube System. When it is needed, use just enough water to keep the blade clean. This saves water, and lowers the risk of staining the boards with water. Usual flow will be 1-2 gallons (3.8-7.6 liters) per hour. A squirt of liquid dishwashing detergent in the water bottle will help clean the blade when cutting wood with a high sap content.



**WARNING!** Use ONLY water with the water lube accessory. Never use flammable fuels or liquids. If these types of liquids are necessary to clean the blade, remove it and clean with a rag. Failure to do so may result in serious injury or death.

Before removing the blade, engage the clutch/brake lever. Let the blade spin with water running on it for about 15 seconds. This will clean the blade of sap buildup. Wipe the blade dry with a rag before storing or sharpening.

If you are sawing in freezing temperatures, remove the water lube bottle from the sawmill when done sawing and store it in a warm place. Blow any remaining water from the water lube hose.

### 3.15 Transporting the Sawmill

The assembled sawmill can be transported in an appropriately equipped pickup truck:

1. Adjust the saw head up just far enough so it will clear the sides of your truck bed when loaded. Do not adjust the saw head so high that the sawmill will tip easily while being loaded.
2. Move the saw carriage to one end of the frame. Engage the travel lock pin to prevent the saw carriage from moving. Pull the pin and rotate and release so the roll pin seats in the locking position notch.

See Figure 3-16.

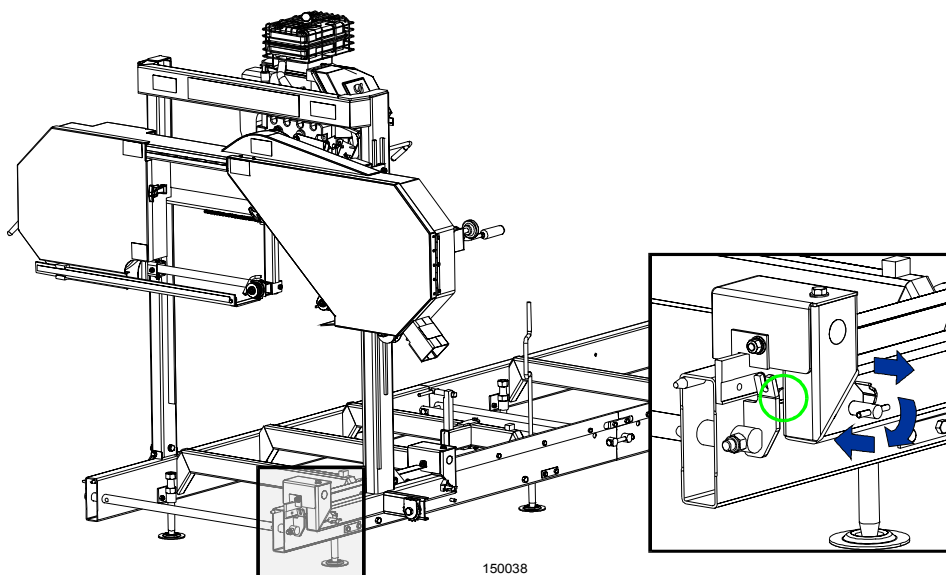

**FIG. 3-16**

3. Remove the leg assemblies or adjust them above the bottom of the bed frames.
4. Position the bed of the truck at the end of the frame opposite the saw head.
5. While two people lift the end of the frame without the sawhead, back the truck under the sawmill until the the end of the frame is resting firmly on the bed of the truck.
6. With a person positioned on either side of the saw head, disengage the travel lock pin. Push the saw carriage up the bed frame and engage the travel lock pin in the end of the frame in the truck bed.

7. Use two people to lift the end of the mill still on the ground and slide the sawmill into the truck bed.



**WARNING!** Keep all persons out of the path of the saw head while loading and unloading the sawmill. Failure to do so may result in serious injury or death.

8. Secure the sawmill to the truck bed to prevent the sawmill from shifting while it is being transported.

# **3** Setup & Operation

*Transporting the Sawmill*

---



# Wood-Mizer LT15 Short Interval Maintenance Schedule

(Check engine and option manuals for additional maintenance procedures)

PROCEDURE	MANUAL REFERENCE
<b>EVERY BLADE CHANGE</b>	
Check Blade Guide Roller Performance	<a href="#">SEE SECTION 4.2</a>
Remove Excess Sawdust From Blade Wheel Housings And Sawdust Chute	<a href="#">SEE SECTION 4.2</a>
<b>EVERY 8 HOURS</b>	
Clean And Lubricate Track	<a href="#">SEE SECTION 4.3</a>
Remove Sawdust From Upper Cam Housings	<a href="#">SEE SECTION 4.3</a>



## WOOD-MIZER LT15 MAINTENANCE LOG

(Check Engine And Option Manuals For Additional Maintenance Procedures)

PROCEDURE	MANUAL REFERENCE	TOTAL HOURS OF OPERATION									
		<i>FILL IN THE DATE AND THE MACHINE HOURS AS YOU PERFORM EACH PROCEDURE. A SHADED BOX INDICATES MAINTENANCE IS NOT NEEDED AT THIS TIME.</i>									
		50 HRS	100 HRS	150 HRS	200 HRS	250 HRS	300 HRS	350 HRS	400 HRS	450 HRS	500 HRS
Clean & lube mast	<a href="#">See Section 4.4</a>										
Oil chains	<a href="#">See Section 4.5</a>										
Rotate drive/idle blade wheel belts/Check for wear	<a href="#">See Section 4.6</a>										
Check up/down chain tension	<a href="#">See Section 4.7</a>										
Lubricate blade tensioner screw	<a href="#">See Section 4.5</a>										

## WOOD-MIZER LT15 MAINTENANCE LOG

(Check Engine And Option Manuals For Additional Maintenance Procedures)

PROCEDURE	MANUAL REFERENCE	TOTAL HOURS OF OPERATION									
		<i>FILL IN THE DATE AND THE MACHINE HOURS AS YOU PERFORM EACH PROCEDURE. A SHADED BOX INDICATES MAINTENANCE IS NOT NEEDED AT THIS TIME.</i>									
		550 HRS	600 HRS	650 HRS	700 HRS	750 HRS	800 HRS	850 HRS	900 HRS	950 HRS	1000 HRS
Clean & lube mast	<a href="#">See Section 4.4</a>										
Oil chains	<a href="#">See Section 4.5</a>										
Rotate drive/idle blade wheel belts/Check for wear	<a href="#">See Section 4.6</a>										
Check up/down chain tension	<a href="#">See Section 4.7</a>										
Lubricate blade tensioner screw	<a href="#">See Section 4.5</a>										

## WOOD-MIZER LT15 MAINTENANCE LOG

(Check Engine And Option Manuals For Additional Maintenance Procedures)

PROCEDURE	MANUAL REFERENCE	TOTAL HOURS OF OPERATION									
		<i>FILL IN THE DATE AND THE MACHINE HOURS AS YOU PERFORM EACH PROCEDURE. A SHADED BOX INDICATES MAINTENANCE IS NOT NEEDED AT THIS TIME.</i>									
		1050 HRS	1100 HRS	1150 HRS	1200 HRS	1250 HRS	1300 HRS	1350 HRS	1400 HRS	1450 HRS	1500 HRS
Clean & lube mast	See Section 4.4										
Oil chains	See Section 4.5										
Rotate drive/idle blade wheel belts/Check for wear	See Section 4.6										
Check up/down chain tension	See Section 4.7										
Lubricate blade tensioner screw	See Section 4.5										

## WOOD-MIZER LT15 MAINTENANCE LOG

(Check Engine And Option Manuals For Additional Maintenance Procedures)

PROCEDURE	MANUAL REFERENCE	TOTAL HOURS OF OPERATION									
		<i>FILL IN THE DATE AND THE MACHINE HOURS AS YOU PERFORM EACH PROCEDURE. A SHADED BOX INDICATES MAINTENANCE IS NOT NEEDED AT THIS TIME.</i>									
		1550 HRS	1600 HRS	1650 HRS	1700 HRS	1750 HRS	1800 HRS	1850 HRS	1900 HRS	1950 HRS	2000 HRS
Clean & lube mast	See Section 4.4										
Oil chains	See Section 4.5										
Rotate drive/idle blade wheel belts/Check for wear	See Section 4.6										
Check up/down chain tension	See Section 4.7										
Lubricate blade tensioner screw	See Section 4.5										





## SECTION 4 MAINTENANCE

This section lists the maintenance procedures that need to be performed.

The Short Interval Maintenance Schedule lists procedures that need to be performed every 4, 8 or 25 hours. The Maintenance Log lists procedures that need to be performed every 50, 100, 200, or 1000 hours. Keep track of machine maintenance by filling in the machine hours and the date you perform each procedure.



**This symbol** identifies the interval (hours of operation) at which each maintenance procedure should be performed.

Be sure to refer to option and engine manuals for other maintenance procedures.

### 4.1 Wear Life

**See Table 4-1.** This chart lists estimated life expectancy of common replacement parts if proper maintenance and operation procedures are followed. Due to the many variables which exist during sawmill operation, actual part life may vary significantly. This information is provided so that you may plan ahead in ordering replacement parts.

Part Description	Estimated Life
B57 Blade Wheel Belts	500 hours
Blade Guide Rollers	1000 hours
Drive Belt	1250 hours

**TABLE 4-1**

### 4.2 Sawdust Removal

Remove the excess sawdust from the blade wheel housings and sawdust chute every blade change.

### 4.3 Carriage Track & Rollers

See Figure 4-1.

1. Clean the track rails to remove any sawdust and sap buildup every eight hours of operation.
2. Remove sawdust from the track roller housings. Remove the track roller housing covers and brush any sawdust buildup from the housings.

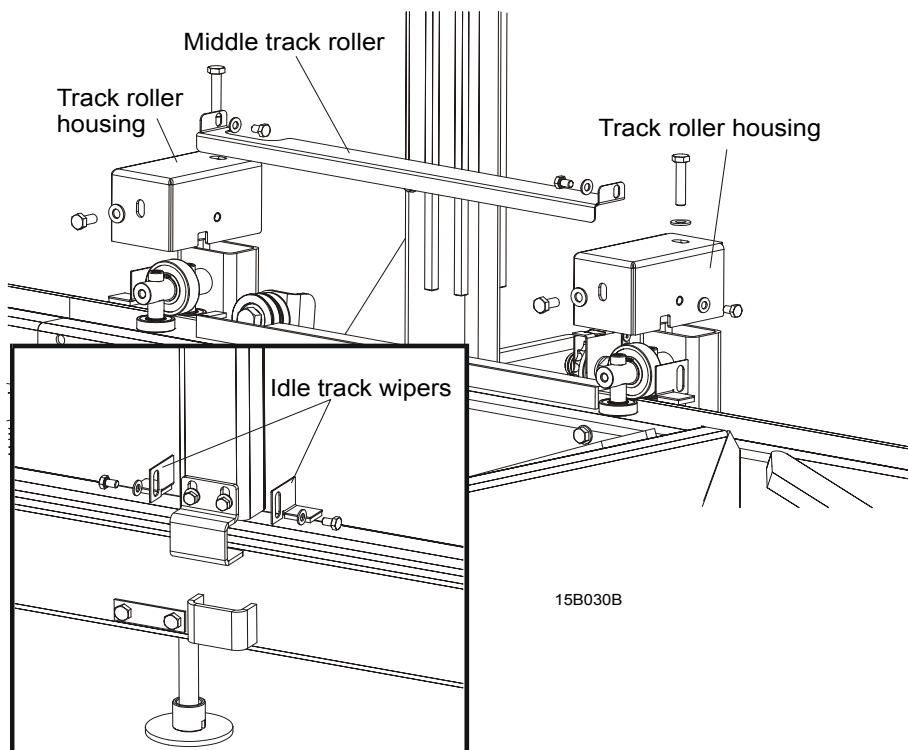

FIG. 4-1

### 4.4 Vertical Mast Rails

- 50 Clean and lubricate the vertical mast rails every 50 hours of operation. Clean with solvent and remove any rust with a light-grade sand paper or emery cloth. Lubricate the mast with motor oil or automatic transmission fluid (ATF).



**CAUTION!** Never use grease on the mast rails as it will collect sawdust.



## 4.5 Miscellaneous Lubrication

1. Oil all chains with Dexron III ATF every fifty hours of operation.



**CAUTION!** Do not use chain lube. It causes sawdust buildup in chain links.

2. Lubricate the tensioner screw with a NLGI No. 2 grade lithium grease as needed.

See Figure 4-2.

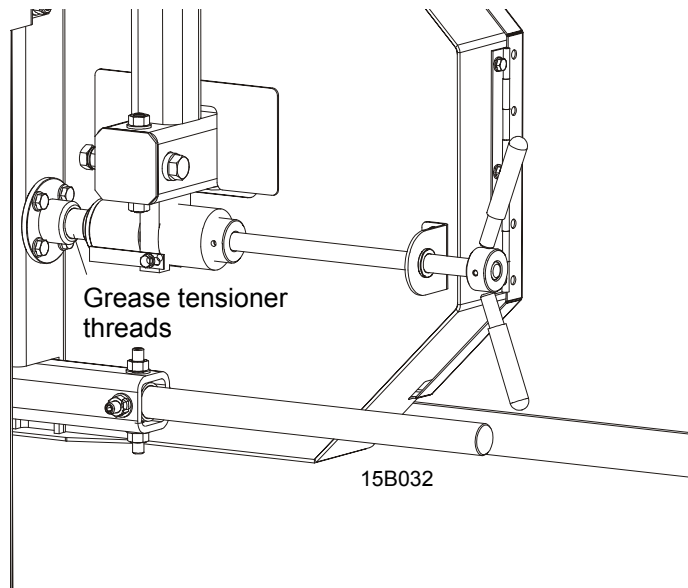

FIG. 4-2

## 4.6 Blade Wheel Belts

1. Rotate the blade wheel belts and check them for wear. Rotating the belts every 50 hours will give you longer belt life. Replace belts as necessary. Use only B57 belts manufactured by Goodyear or Browning.
2. Periodically check all belts for wear. Replace any damaged or worn belts as needed.

50

## 4.7 Up/Down System

1. Adjust the up/down chain tension as needed. Measure chain tension with the head all the way to the top of the vertical mast. Secure the carriage with a chain at the top, or shim it underneath. Find the chain adjusting bolt at the bottom of the mast. Loosen the nut on the bolt and move the sprocket down until there is about 1" (2.5 cm) total deflection in the center of the chain with a 5 lb. (2.3 Kg) deflection force.



**WARNING!** Always secure the cutting head with a chain or a brace before adjusting the up/down chain. The cutting head may fall, causing severe injury or death.

See Figure 4-3.

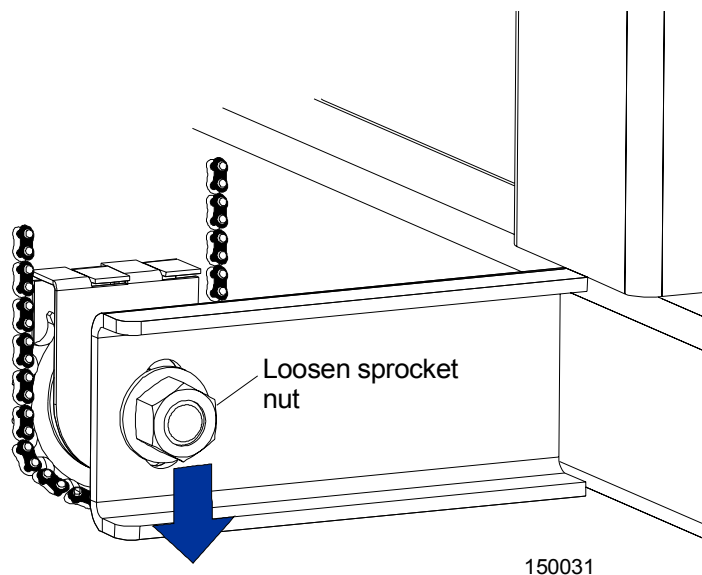

**FIG. 4-3**

## 4.8 Miscellaneous Maintenance

-  1. Check the drive belt tension after the first 20 hours, and every 50 hours thereafter. Drive belt adjustment differs according to the specified motor or engine. See the Wood-Mizer Motor or Engine Option manual supplied with your mill for specific adjustment instructions.
2. Check the mill alignment every setup. See Section 6, Alignment.
3. If the clutch begins to slip, adjust the turnbuckle linkage. Turn the turnbuckle clockwise (as viewed from the top) to provide 46 lbs. of tension.
4. Make sure all safety warning decals are readable. Remove sawdust and dirt. Replace any damaged or unreadable decals immediately. Order decals from your Customer Service Representative.



## SECTION 5 TROUBLESHOOTING GUIDE

### 5.1 Sawing Problems

<b>PROBLEM</b>	<b>CAUSE</b>	<b>SOLUTION</b>
<b>Blades Dull Quickly</b>	Dirty logs	Clean or debark logs, especially on entry side of the cut
	When grinding teeth, heating too much and causing teeth to soften	Grind just enough metal to restore sharpness to the teeth. Use water/coolant while sharpening blade
	Poor sharpening techniques	Make sure the tip is being sharpened completely (See Sharpener Manual)
<b>Blades Break Prematurely</b>	Rubber belts on blade wheels worn to a point that blade contacts metal pulley - look for shiny spots on edge of wheels	Change blade wheel belts (B-57)
	Poor sharpening techniques	See Sharpener Manual
	Tension too tight	Tension blade to recommended specifications
<b>Blade Does Not Track Right on Drive Wheel</b>	Cant adjustment is incorrect	Readjust
	Flat/worn belts	Replace B-57 belts
<b>Blade Guides Do Not Spin While Cutting</b>	Frozen bearings	Replace bearings
	Stiff bearings	Grease bearings
<b>Drive Belts Wear Prematurely or Jump</b>	Engine/motor and drive pulleys out of alignment	Align pulleys

# 5 Troubleshooting Guide

## Sawing Problems

<b>PROBLEM</b>	<b>CAUSE</b>	<b>SOLUTION</b>
<b>Boards Thick Or Thin On Ends Or Middle Of Board</b>	Stress in log which causes log to not lay flat on the bed	After log has been squared, take equal cuts off opposing sides. Take a board off the top. Turn the log 180 degrees. Take a board off. Repeat, keeping the heart in the middle of the cant, and making it your last cut
	Set in teeth	Resharpen and reset blade
	Bed rails misaligned	Realign sawmill.
<b>Height Adjustment Jumps or Stutters When Moving Up or Down</b>	Mast needs lubrication	Lubricate mast track surface
	Up/down chain improperly adjusted	Adjust up/down chain.
	Vertical wear pads are too tight	Adjust pads.
<b>Lumber Is Not Square</b>	Vertical side supports not square to bed	Adjust side supports.
	Blade not parallel to bed rails	Adjust bed rails parallel to blade.
	Sawdust or bark between cant and bed rails	Remove particles
<b>Sawdust Builds Up On Track</b>	Tooth set problems	Resharpen and reset blade
	Excessive oiling	Do not oil track
	Track is sticky	Clean track with solvent and apply silicone spray
<b>Wavy Cuts</b>	Excessive feed	Slow feed rate
	Improperly sharpened blade (This will be the problem 99% of the time!)	Resharpen blade (See Sharpener Manual - read entire manual!)
	Blade guides improperly adjusted	Adjust blade guides.
	Sap buildup on blade	Use Water Lube.
	Tooth set problem	Resharpen and reset blade

## SECTION 6 ALIGNMENT

### 6.1 Pre-Alignment Procedures

Periodically check the sawmill alignment and adjust if necessary. This chapter explains how to align the entire sawmill. Care should be taken in performing these steps. Sawmill alignment determines the accuracy and squareness of your cuts.

**The sawmill alignment steps are:**

1. Ready the sawmill for alignment
2. Adjust the blade parallel to the bed rails
3. Adjust the blade guide arm parallel to the saw head brace
4. Align blade guides to the blade
5. Adjust side supports square to the bed
6. Final Adjustments

To insure accurate alignment, the sawmill frame must be level and a blade properly installed.

[See SECTION 3 Setup & Operation](#) for setup information.



## Alignment

### *Preparing The Sawmill For Alignment*

---

## 6.2 Preparing The Sawmill For Alignment

Before performing the following alignment procedures, setup the mill on firm, level ground. String the bed and adjust the legs so the frame is level as described in [Section 3.1](#).



### 6.3 Blade Installation and Alignment

Install a blade and apply the appropriate tension as shown in [Section 3.3](#).

1. Raise the middle blade housing cover and make sure all persons are clear of the open side of the saw head.
2. Start the engine.
3. Pull lightly on the clutch handle, rotating the blade until the blade positions itself on the wheels.



**WARNING!** Do not spin the blade wheels by hand. Spinning the blade wheels by hand may result in serious injury.

4. Release the clutch handle to stop the blade. Turn off the engine, remove the key and check the position of the blade on the blade wheels.

Check the vertical alignment of the idle-side blade wheel. The gullet of the blade should ride the same distance from the front edge of the wheel at the top and bottom of the wheel. If it does not, loosen and tighten the appropriate adjustment screws on the wheel shaft.

**See Figure 6-1.** The blade wheels should be adjusted so that the gullet of 1 1/4" blades ride 1/8" (3 mm) out from the front edge of the wheels ( $\pm 1/32$  [0.8 mm]). The gullet of 1 1/2" blades should ride 3/16" (4.5 mm) from the front edge of the wheels ( $\pm 1/32$  [0.8 mm]). Do not let the teeth ride on the wheels.

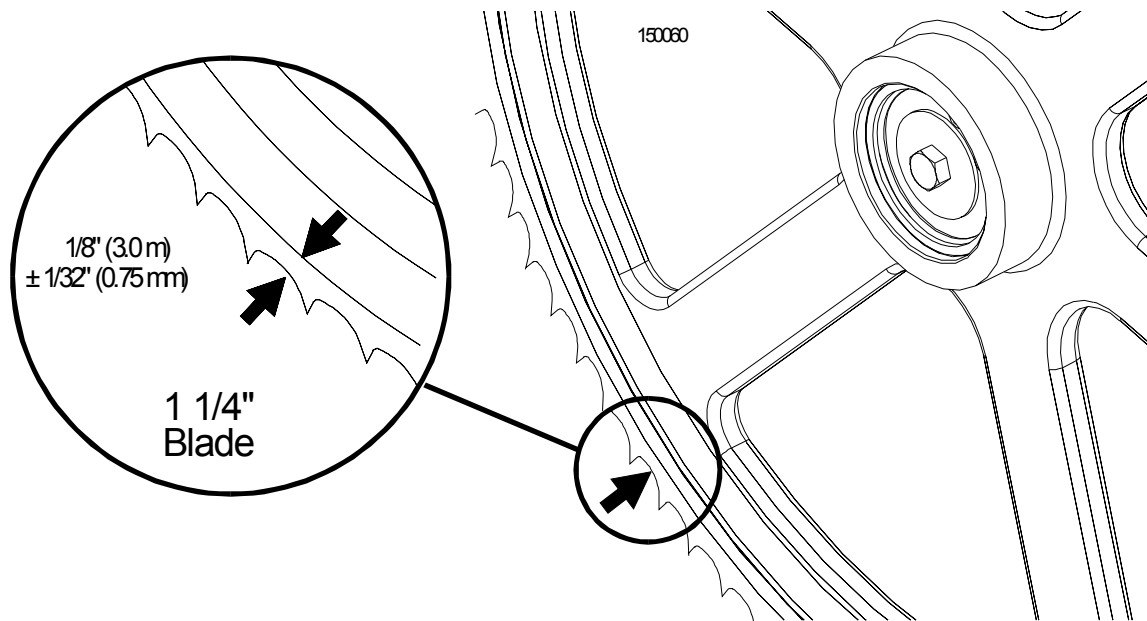

FIG. 6-1

To adjust where the blade travels on the idle-side blade wheel, use the cant control shown in **Figure 5-1**.

If the blade is too far forward on the wheels, turn the cant control counterclockwise. If it is too far back on the wheels, turn the cant control clockwise.

Some adjustment in blade tension may be needed to compensate for adjustments made with the cant control.

Adjustment with the cant control handle is usually all that is required to track the blade properly on both blade wheels. The drive-side blade wheel will usually not have to be adjusted. If necessary, the drive-side wheel can be adjusted as follows:

Look at the drive shaft from the side. Locate the U-bolt on the right holding the bearing housing to the mounting plates.

Locate the jam nuts on the U-bolt between the two mounting plates. If the blade is running too far to the front of the drive-side blade wheel, turn the jam nuts toward the bearing housing. If the blade is too far back, turn the nuts away from the bearing housing. Make sure to tighten the jam nuts against the mounting plates when adjustment is complete.

## 6.4 Blade Guide Arm Alignment

Before aligning the blade guide arm, track the blade on the blade wheels as described in [Section 3.4](#). Move the carriage so the blade is positioned over the first bed rail. Level the blade to the bed rail as shown in [Section 3.1](#). Adjust the blade guide rollers so they do not touch the blade.

### Vertical Alignment

1. Adjust the blade guide arm all the way out away from the other blade guide.

See Figure 6-2.

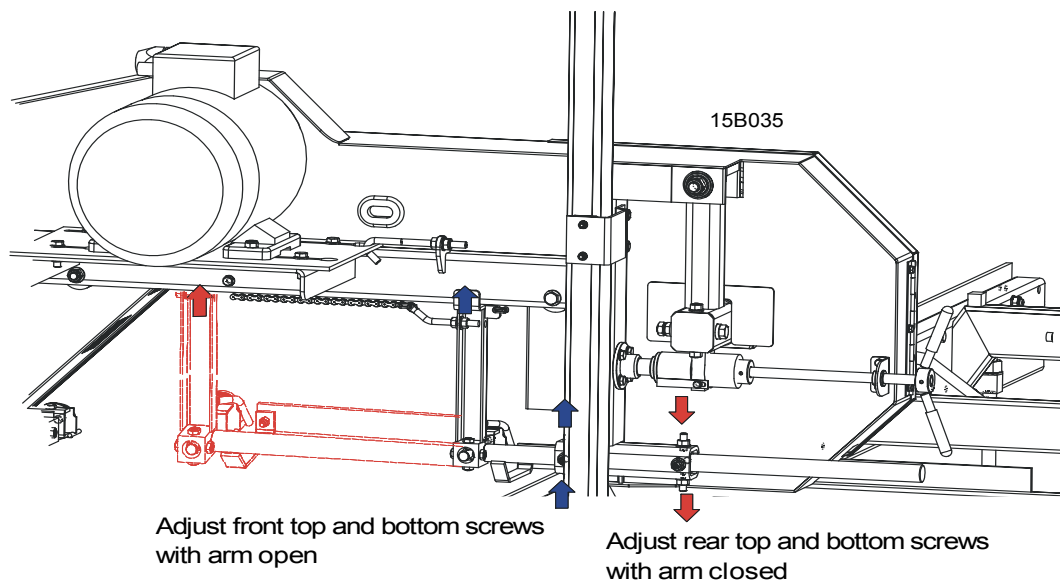

**FIG. 6-2**

2. Use the inside top and bottom screws to adjust the arm up until the slide pad touches the saw head brace tube. Tighten the jam nuts.
3. Adjust the blade guide arm in all the way toward the other blade guide.
4. Use the outside top and bottom screws to adjust the arm up until the slide pad touches the saw head brace tube. Tighten the jam nuts.

**NOTE:** When adjusting the blade guide arm screws, be careful not to tighten the screws too much or put the arm in a bind. Operate the blade guide arm knob to ensure the arm moves easily in and out when the knob is turned.

**Horizontal Alignment****See Figure 6-3.**

1. With the blade guide arm still all the way in toward the other blade guide, tighten all the side screws until they touch the arm. Back the screws off 1/4 turn and tighten the jam nuts.
2. Sight across the horizontal saw head brace to view the blade guide arm. Adjust all side screws on the blade guide arm housing so the arm is parallel to the saw head brace.
3. To move the blade guide end of the arm toward the front of the sawmill, loosen jam nuts on the front inside screw and the rear outside screw. Turn the screws counterclockwise one full turn and tighten the jam nuts. Loosen the jam nuts on the front outside screw and the rear inside screw. Turn the screws clockwise until they touch the arm, back off 1/4" turn, and tighten the jam nuts.
4. To move the blade guide end of the arm toward the rear of the sawmill, loosen jam nuts on the front outside screw and the rear inside screw. Turn the screws counterclockwise one full turn and tighten the jam nuts. Loosen the jam nuts on the front inside screw and the rear outside screw. Turn the screws clockwise until they touch the arm, back off 1/4" turn, and tighten the jam nuts.

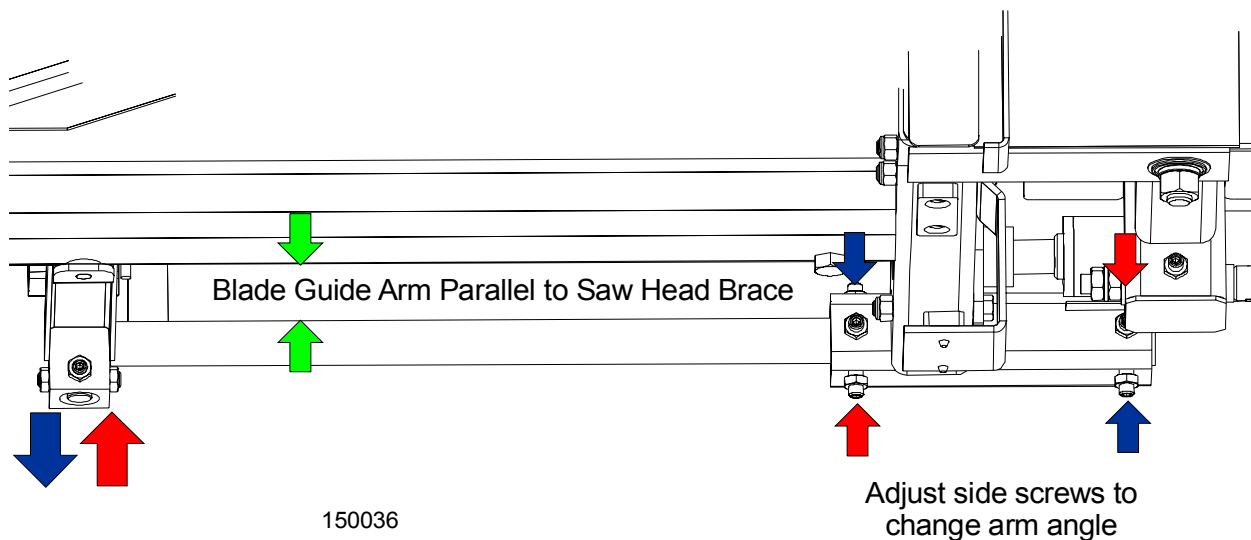
**FIG. 6-3**

## 6.5 Aligning The Blade Guides

Each Wood-Mizer sawmill has two blade guide assemblies that help the blade maintain a straight cut. The two blade guide assemblies are positioned on the saw head to guide the blade on each side of the material being cut.

One blade guide assembly is mounted in a stationary position on the drive side of the saw head. This assembly is referred to as the "inner" blade guide assembly.

The other blade guide assembly is mounted on the idle side of the saw head. It is referred to as the "outer" assembly and is adjustable for various widths of materials to be processed.

Blade guide alignment includes four steps:

- Blade Deflection
- Blade Guide Vertical Tilt
- Blade Guide Flange Spacing
- Blade Guide Horizontal Tilt

Perform the blade guide alignment after you have aligned the blade on the wheels and adjusted the blade and blade guide arm parallel to the bed rails. After blade guide alignment, check the scale indicator to make sure it is adjusted properly.

## 6.6 Blade Deflection

Perform the following steps to achieve proper blade deflection with the blade guides.

1. Raise the carriage until the blade is 15" (375 mm) above a bed rail. Measure the actual distance with a tape from the top of the rail to the bottom of the blade.

See Figure 6-4.

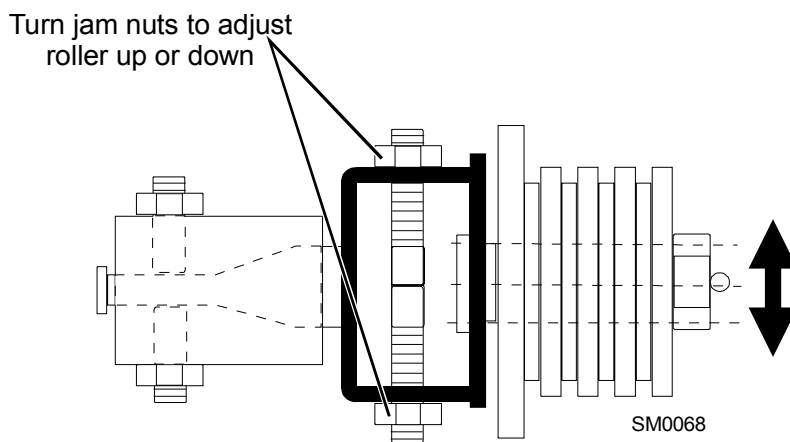

FIG. 6-4

2. Loosen the bottom jam nut and tighten the top jam nut until the blade guide deflects the blade down 1/4" (6.5 mm).
3. Repeat for the other blade guide.

**NOTE:** Be sure that the blade guard clears the blade on both guide assemblies. The guard on the outer guide assembly should be checked with the arm all the way in and all the way out.

## 6.7 Blade Guide Vertical Tilt Adjustment

Check that the blade guide does not tilt the blade up or down. A Blade Guide Alignment Tool (BGAT) is provided to help you measure the vertical tilt of the blade.

1. Open the adjustable blade guide arm 1/2" (15 mm) from full open.
2. Clamp the alignment tool on the blade. Position the tool close to a blade guide roller. Be sure the tool does not rest on a tooth or burr, and is lying flat on the blade.

See Figure 6-5.

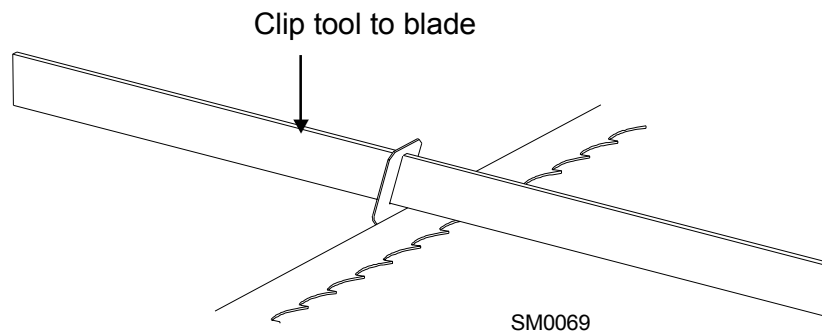

FIG. 6-5

3. Measure the distance from the bed rail to the bottom of the tool.
4. Move the carriage so that the front end of the tool is positioned above the bed rail.
5. Measure the distance from the bed rail to the bottom edge of the tool.
6. Loosen one set screw at the side of the blade guide assembly.
7. Use the set screws shown to tilt the blade guide until the measurement from the bed rail to the tool equals the first measurement taken at the center of the tool.

See Figure 6-6.

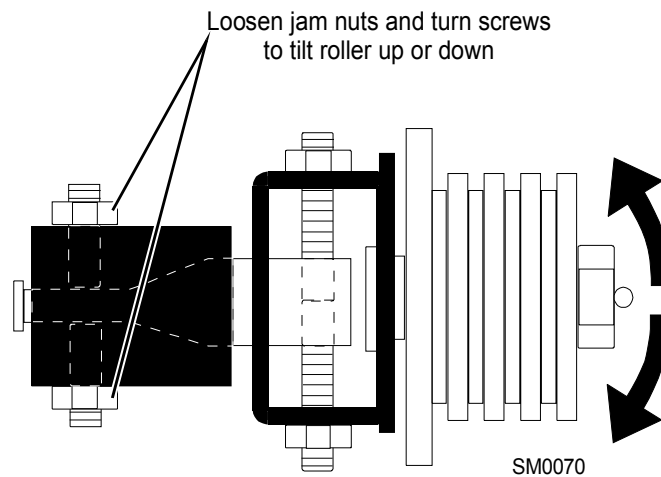

FIG. 6-6

8. Move the carriage forward so the back end of the tool is over the bed rail.
9. Use the set screws shown to adjust the blade guide tilt until the measurement from the bed rail to the tool equals the other two measurements taken.
10. Move the tool close to the other blade guide and repeat the previous steps.

**NOTE:** If major adjustments to blade guide tilt were made, remeasure the distance between the blade and the bed rails to ensure the correct 1/4" (6.5 mm) blade guide deflection. Adjust if necessary.



## 6.8 Blade Guide Spacing

**HINT:** When adjusting blade guide spacing, loosen the top set screw and one side set screw only. This will insure horizontal and vertical tilt adjustments are maintained when the set screws are retightened.

1. Adjust the inner blade guide so the blade guide flange is approximately 1/16" - 1/8" (1.5 - 3.0 mm) from the back of the blade.
2. Loosen one side and one top set screw shown. Tap the blade guide forward or backward until properly positioned.

See Figure 6-7.

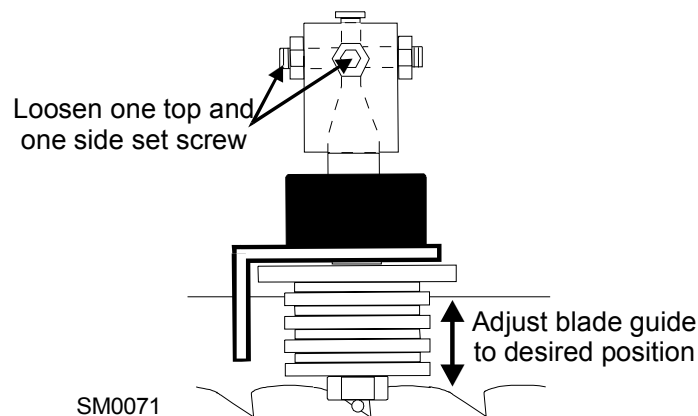

**FIG. 6-7**

3. Retighten the two set screws.
4. Adjust the outer blade guide in the same way so the blade guide flange is approximately 1/16" - 1/8" (1.5 - 3.0 mm) from the back of the blade.

## 6.9 Horizontal Tilt Adjustment

1. Finally, both blade guides must be tilted horizontally. Adjust the blade guide arm half way in.

See Figure 6-8.

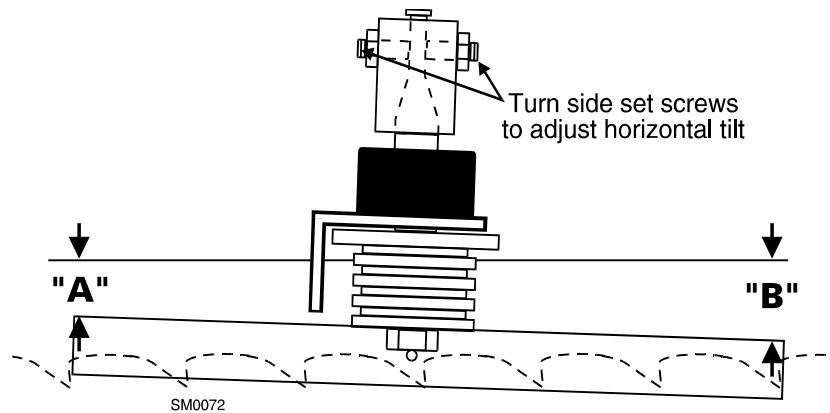

**FIG. 6-8**

2. Place Blade Guide Alignment Tool against the face of the outer blade guide roller.
3. Center the tool on the roller and measure between the back edge of the blade and the ruler at the end closest to the inner blade guide ("B").
4. Measure between the back edge of the blade and the other end of the ruler ("A").
5. The roller should be parallel to the blade ( $A=B$ ) or tilted slightly to the left ( $A=B-1/4"$  [6 mm]).
6. Use the side set screws to adjust the horizontal tilt of the roller.
7. Repeat Steps 3 - 7 for the inner blade guide roller.

**NOTE:** Once the blade guides have been adjusted, any cutting variances are most likely caused by the blade. See **Blade Handbook, Form #600**.

## 6.10 Side Supports

Logs and boards are clamped against the side supports when sawing. The side supports must be square to the bed to ensure square lumber.

1. Place a flat board across the bed rails.

See Figure 6-9.

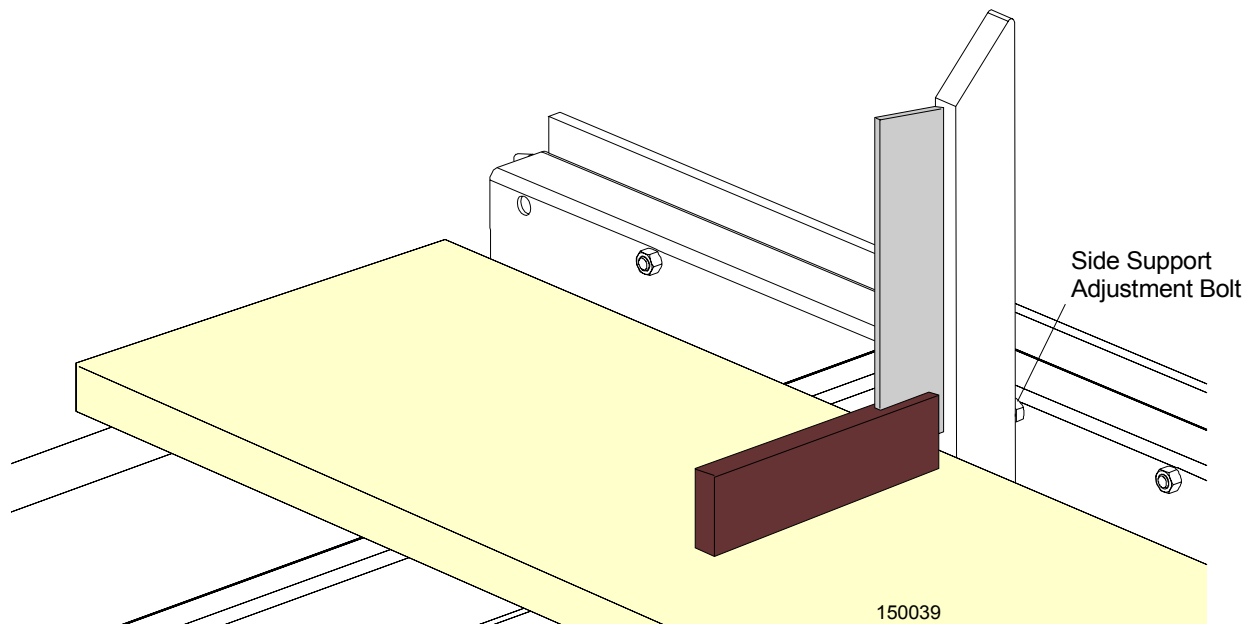

FIG. 6-9

2. Swing a side support up so that it is vertical.
3. Pull back at the top of the support to eliminate slack as if a log were being clamped against it.
4. Check the angle of each support with a square on the board.
5. The side support should be 90° to the bed rails or leaning forward 1/32" (0.8 mm). Turn the adjustment bolt counterclockwise to tilt the top of the side support forward.
6. Repeat for the remaining side supports.

## 6.11 Blade Height Scale Adjustment

After the entire sawmill has been aligned and all adjustments made, check that the blade height scale indicates the true distance from the blade to the bed rails.

1. Move the saw head so the blade is positioned directly above one of the bed rails. Measure from the bottom edge on a down-set tooth of the blade to the top of the bed rail (or stainless steel sleeve if applicable).

See Figure 6-10.

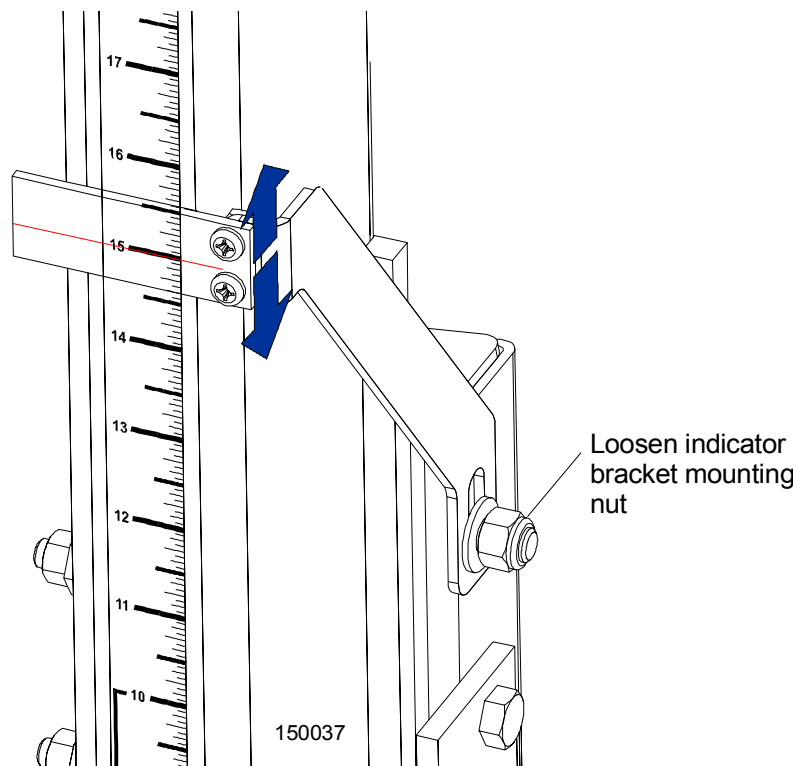

FIG. 6-10

2. Loosen the indicator bracket mounting bolts and adjust the bracket until the indicator is aligned with the correct mark on the scale (+0 -1/32 [0.8 mm]). Retighten the bracket mounting nut.

For example, if the measurement from blade to bed rail was 14 3/4" (375 mm), make sure the indicator reads 14 3/4" (375 mm) on the scale.