



user manual

Instrukcja obsługi | Руководство пользователя
Manuel de l'Utilisateur | Betriebsanweisung
Bruksanvisning | Manual del Usuario
Betjeningsvejledning | Gebruikershandleiding
Käyttöohjeet | Manual de utilizare | Bruksanvisning
Manuale d'uso | Příručka uživatele | Navodila
za uporabo

Retain for future use
Zachować do przyszłego użytku
Сохраните для последующего
использования
A conserver pour une utilisation future
Für zukünftige Benutzung aufbewahren
Behold for senere bruk
Säilytä nämä käyttöohjeet tulevaa tarvetta marten
Opbevar manualen til fremtidig brug
Bewaren voor gebruik in de toekomst
Conservare il presente manuale a l'uso futuro
Păstrați acest manual pentru utilizare viitoare
Conservar para futuras consultas
Behall för framtida användning
Uchovejte pro další použití
Hranite za prihodnjo uporabo

Wood-Mizer®

Safety, Setup, Operation & Maintenance Manual

LTSC15S3 G18	rev. A2.06
LTSC15M2 G18	rev. A2.06
LTSC15S3 D10	rev.A2.06
LTSC15M2 D10	rev. A2.06



Safety is our #1 concern! Read and understand all safety information and instructions before operating, setting up or maintaining this machine.

Form #798

Original Instructions



IMPORTANT! Read the entire Operator's Manual before operating the sawmill. Take notice of all safety warnings throughout this manual and those posted on the machine. Keep this manual with this machine at all times, regardless of ownership.

SECTION 1 SAFETY & GENERAL INFORMATION 1-1

1.1	Blade Handling.....	1-1
1.2	Sawmill Setup.....	1-2
1.3	Sawmill Operation.....	1-2
1.4	Sawmill Maintenance	1-4
1.5	Safety Instructions	1-5
	<i>Observe Safety Instructions</i>	
	<i>Wear Safety Clothing</i>	
	<i>Keep sawmill And Area Around sawmill Clean</i>	
	<i>Dispose Of Sawing By-Products Properly</i>	
	<i>Check sawmill Before Operation</i>	
	<i>Keep Persons Away</i>	
	<i>Keep Hands Away</i>	
	<i>Use Proper Maintenance Procedures</i>	
	<i>Keep Safety Labels In Good Condition</i>	
1.6	Belt Sizes	1-15
1.7	Blade Sizes	1-15
1.8	Cutting Capacity	1-16
1.9	Engine/Motor Specifications	1-16
1.10	Noise Level.....	1-16
1.11	Dust Extractor Specifications	1-17
1.12	Overall Dimensions	1-18
1.13	Components	1-19

SECTION 2 SAWMILL ASSEMBLY 2-1

2.1	Mounting Parts of LT15 Sawmills with Gas Engine.....	2-1
	<i>Parts Specifications</i>	
	<i>Specifications of Fasteners</i>	
	<i>Tools Necessary for Assembling the Sawmill</i>	
2.2	Unpacking the Sawmill	2-9
2.3	Bed Frame Assembly	2-11
2.4	Frame Leg Adjustment.....	2-16
2.5	Saw Head Assembly	2-17
2.6	Feed Rope Assembly.....	2-19
2.7	Power Feed Rope Assembly.....	2-23
2.8	Auxiliary Bed Rail.....	2-25
2.9	Log Loading Ramp (Option)	2-26
2.10	Installation of the Fuel Hoses	2-27

SECTION 3 SETUP & OPERATION**3-1**

3.1	Sawmill Setup.....	3-1
3.2	Replacing The Blade	3-8
3.3	Tensioning The Blade.....	3-9
3.4	Tracking The Blade	3-10
3.5	Starting The Engine.....	3-11
3.6	Loading, Turning, And Clamping Logs	3-12
3.7	Up/Down Operation	3-15
3.8	Blade Guide Arm Operation.....	3-16
3.9	Blade Drive Operation.....	3-16
3.10	Feed Operation	3-17
3.11	Cutting The Log	3-20
3.12	Edging.....	3-21
3.13	Blade Height Scale	3-21
3.14	Water Lube Operation.....	3-22
3.15	Transporting the Sawmill	3-24

SECTION 4 MAINTENANCE**4-1**

4.1	Wear Life.....	4-1
4.2	Sawdust Removal	4-1
4.3	Carriage Track & Rollers	4-1
4.4	Vertical Mast Rails	4-2
4.5	Miscellaneous Lubrication	4-2
4.6	Blade Wheel Belts	4-3
4.7	Brake Pads Adjustment (Gas / Diesel Sawmills Only)	4-4
4.8	Up/Down System.....	4-4
4.9	Miscellaneous Maintenance	4-6
4.10	Filling Blade Tensioner Cylinder with Oil.....	4-7
4.11	Safety Devices Inspection (CE version only).....	4-9

SECTION 5 TROUBLESHOOTING GUIDE**5-1**

5.1	Sawing Problems	5-1
-----	-----------------------	-----

SECTION 6 ALIGNMENT**6-1**

6.1	Pre-Alignment Procedures.....	6-1
6.2	Preparing The Sawmill For Alignment	6-1
6.3	Blade Installation and Alignment.....	6-1
6.4	Blade Wheel Alignment	6-2
6.5	Blade Guide Arm Alignment.....	6-7
6.6	Aligning The Blade Guides	6-8
6.7	Blade Deflection.....	6-9
6.8	Blade Guide Vertical Tilt Adjustment.....	6-10
6.9	Blade Guide Spacing	6-11
6.10	Horizontal Tilt Adjustment.....	6-12
6.11	Side Supports.....	6-13
6.12	Blade Height Scale Adjustment.....	6-14
6.13	Track Roller Distance Adjustment	6-15
6.14	Setting bottom bracket.....	6-16

Getting Service

Wood-Mizer is committed to providing you with the latest technology, best quality and strongest customer service available on the market today. We continually evaluate our customers' needs to ensure we're meeting current wood-processing demands. Your comments and suggestions are welcome.

General Contact Information

From Europe call your local distributor or our European Headquarters and Manufacturing Facility in Koło, Nagórna 114 St, Poland at **+48-63-2626000**. From the continental U.S., call our U.S. Headquarter 8180 West 10th St.Indianapolis, IN 46214, toll-free at **1-800-525-8100**. Ask to speak with a Customer Service Representative. Please have your machine identification number and your customer number ready when you call. The Service Representative can help you with questions about the operation and maintenance of your machine. He also can schedule you for a service call.

Office Hours:

Country	Monday - Friday	Saturday	Sunday
Poland	7 a.m.- 3 p.m.	Closed	Closed
US	8 a.m.- 5 p.m.	8 a.m.- 12 p.m	Closed

Please have your vehicle identification number and your customer number ready when you call.

Wood-Mizer will accept these methods of payment:

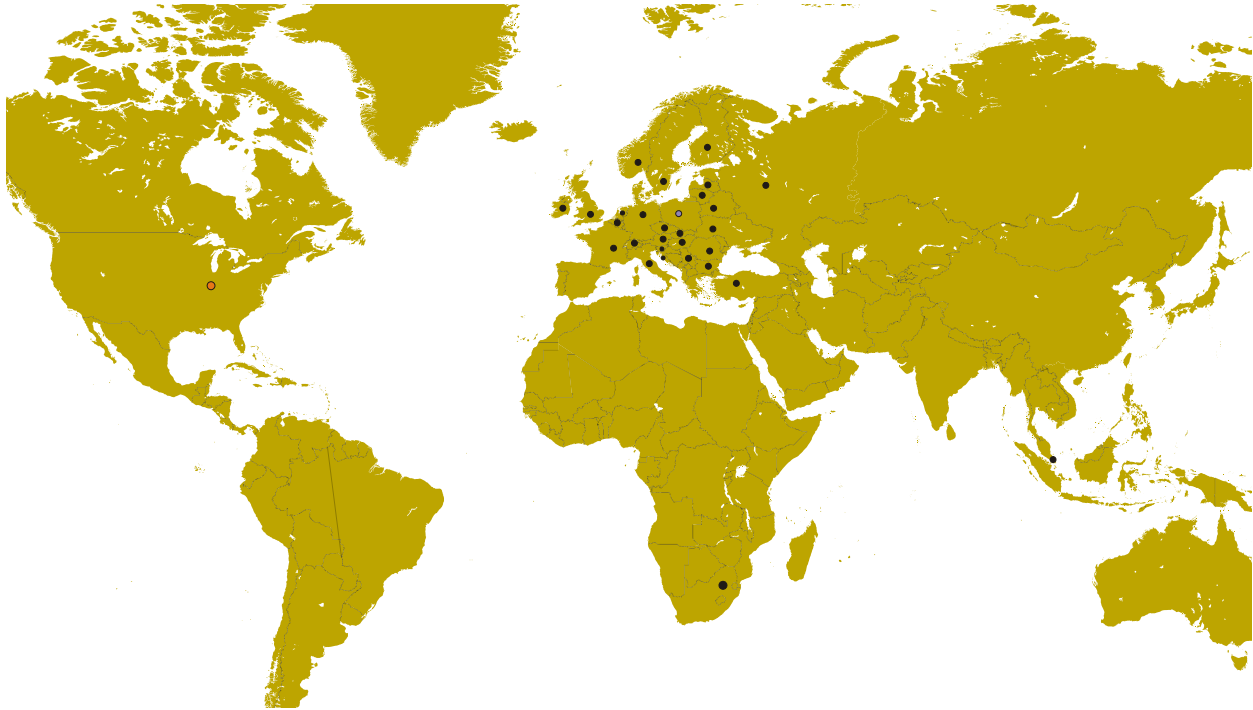
- Visa, Mastercard, or Discover
- COD
- Prepayment
- Net 15 (with approved credit)



Be aware that shipping and handling charges may apply. Handling charges are based on size and quantity of order.

Technical data are subject to change without prior notice.

Actual product may differ from product images. Some illustrations show machines with optional equipment.

Branches & Authorized Sales Centers Wood-Mizer Locations (North and South America)



EUROPE		UNITED STATES
<p> European Headquarters Wood-Mizer Industries Sp. z o.o. Nagórna 114, 62-600 Kolo, Poland Tel.: +48-63-26-26-000 Fax: +48-63-27-22-327 www.woodmizer.eu</p>		<p> World Headquarters Wood-Mizer LLC 8180 West 10th Street Indianapolis, Indiana 46214-2400, USA Tel.: +1-317-271-1542 Fax: +1-317-273-1011 www.woodmizer.com</p>
<p>BELARUS MOST-GRUPP Siemashko 15, k.3 Minsk 2200116 Tel.: +375-17-270-90-08 Fax: +375-17-270-90-08 GSM: +375-29-649-90-80 e-mail: most-by@mail.ru</p>	<p>SWITZERLAND Stefan Wespi Maschinen u. Geräte Spezialarbeiten GmbH Eichstraße 4 6353 Weggis Tel.: +41-413-900-312 GSM: +41-799-643-594 info@woodmizer.ch www.woodmizer.ch</p>	<p>RUSSIA Dariusz Mikołajewski OOO WOOD-MIZER INDUSTRIES 141031, Moscow Reg., Mytishenski raj., pos. Veshki, Zavodskaja str., 3B Tel.Fax: +7(495) 788-72-35 Tel.Fax: +7(495) 641-51-60 e-mail: dariuszm@woodmizer-moscow.ru</p>
<p>BULGARIA Kalin Simeonov Ecotechproduct 38 Star Lozenski pat str. Sofia 1186 Tel.: +359-2-462-7035 Tel.: +359-2-963-1656 Tel./Fax : +359-2-979-1710 Kalin Simeonov GSM: +3592-963-2559 e-mail: office@ecotechproduct.com</p>	<p>HUNGARY Wiktor Turoczy Wood-Mizer Hungary K.F.T. Szonyi Ut 67., 2921 Komárom Tel./Fax: +36-34-346-255 e-mail: woodmizer@woodmizer.hu</p>	<p>RUSSIA Far East Wladimir Glazaczew "WM Service" Krasnoretchenskaya Str.111 680006 Khabarovsk Tel./Fax: +7-914-541-1183 e-mail: wms-khv@mail.ru</p>

<p>CROATIA Krešimir Pregernik Pregimex d.o.o. S. Batušićeva 31, 10090 Zagreb Tel./Fax: +3851-38-94-668 Krešimir Pregernik GSM: +3851-98-207-106 e-mail: Kresimir.Pregernik@gmail.com</p>	<p>ITALY Pasquale Felice Wood-Mizer Italia Srl Cda. Capoiaccio SN 86012 Cercemaggiore Campobasso Tel./Fax: +39-0874-798-357 GSM: +39-333-281-03-79 e-mail: wmitaliasrl@gmail.com</p>	<p>SERBIA Dragan Markov Wood-Mizer Balkan d.o.o. Svetosavska GA 3/3; P. Fah 25 23 300 Kikinda Tel./Fax: +381-230-25-754 Tel./Fax: +381-230-23-567 GSM: +381-63-568-658 e-mail: office@woodmizer.co.yu</p>
<p>CZECH REPUBLIC Miroslav Greill Wood-Mizer CZ s.r.o. Za Kasárny 946 339 01 Klatovy tel: +420-376-312-220 Greill Miroslav GSM: +420 602-439-799 e-mail: woodmizer@woodmizer.cz</p>		<p>SLOVAKIA Wiktor Turoczy Wood-Mizer Danubia s.r.o. Hadovce 5, 94501 Komárno Tel.: +421-35-77-40-316 Fax: +421-35-7740-326 GSM: +421-905-930-972 e-mail: woodmizer@woodmizer.sk</p>
<p>CZECH REPUBLIC Lubomir Kudlik Wood-Mizer Moravia Sovadinova 6 69002 Breclav Tel./Fax: +420-519-322-443 Lubomir Kudlik GSM: +420-602-734-792 e-mail: info@wood-mizer.net</p>	<p>LATVIA Vilmars Jansons OBERTS Ltd Gaujas str. 32/2 LV-2167 Marupe, Rigas Raj. Tel.: +371-7-810-666 Fax: +371-7-810-655 Vilmars Jansons GSM: +371-92-06-966 Andris Orols GSM: +371-28-33-07-90 e-mail: andris@oberts.lv</p>	<p>TURKEY Er-Ka Ahsap Profil Kerestecilik San. ve Tic. Ltd. Sti. Adana Keresteciler Sitesi 191 sk No.41 ADANA Tel.: +90-322-346-15-86 Fax: +90-322-345-17-07 GSM: +90-533-363-18-44 e-mail: info@erkaahsap.com.tr</p>
<p>FINLAND Howard Blackburn Oy Falkberg Jordbruk Ab Falkintie 220 25610 Ylonkyla Tel.: +358-2732-2253 Fax: +358-2732-2263 Howard Blackburn GSM: +358-440-424-339 e-mail: falkberg@woodmizer.fi</p>	<p>LITHUANIA Andrius Zuzevicius UAB Singlis Savanoriu pr. 187, 2053 Vilnius Tel.: +370-5-2-32-22-44 Fax: +370-5-2-64-84-15 GSM: +370-620-28-645 e-mail: andrius.z@singlis.lt</p> <p>Dmitrij Gaiduk GSM: +370-69-84-51-91 e-mail: dmitrijus.g@singlis.lt</p>	<p>UKRAINE Ivan Vinnicki MOST UKRAINA bul. Myru 3, Bajkivtsi Ternoplskyj r-j Ternopolska oblast 47711 Ukraine Tel/Fax: +38 (0352) 52 37 74 GSM: +38 (067) 352 54 34 GSM: +38 (067) 674 50 68 E-mail: most-ukraine@ukr.net</p>
<p>FRANCE Tizoc Chavez Wood-Mizer France 556 chemin des Embouffus, ZAC des Basses Echarrieres 38440 SAINT JEAN DE BOURNAY Tel: +33-4 74 84 84 44 GSM: +33-607 52 02 82 Mail: tchavez@woodmizer.fr</p>	<p>NORWAY Tor Bakken Flaathe Bakken Flaathe A/S Løkenvegen 5, 2034 Holter Tel: + 47-638 74 989 Sales: + 47- 412 80 076 Service: +47- 975 87 588 post@woodmizer.no www.woodmizer.no</p>	<p>UNITED KINGDOM & IRELAND Wood-Mizer UK Hopfield Barn Kenward Road, Yalding Kent ME18 6JP, UK Tel.: +44-1622-813-201 Fax: +44-1622-815-534 e-mail: info@woodmizer.co.uk</p>
<p>SLOVENIA Jan Fale FAMTEH d.o.o. Gacnikova pot 2, 2390 Ravne na Koroskem Tel.: +386-2-62-04-232 Fax: +386-2-62-04-231 Jan Fale GSM: +386-2-62-04-230 e-mail: jan.fale@famteh.si</p> <p>Matjaz Kolar Tel.: +386-2-62-04-232 GSM: +386-31-775-999 e-mail: matjaz.kolar@famteh.si</p>		

<p>GERMANY/AUSTRIA Klaus Longmuss Wood-Mizer GmbH Dorfstraße 5, 29485 Schletau Büro Tel: +49-5883 988 010 Werkstatt Tel: +49-5883 988 220 Ersatzteilservice Tel: +49 58 83 - 98 80 250 Schärfservice Tel: +49-58 83 - 98 80 270 E-mail: info@woodmizer.de www.woodmizer.de Klaus Longmuss Tel.: +49-5883-9880-12 GSM: +49-17-298-55-892 e-mail: KLongmuss@woodmizer.de</p>	<p>Subagent: SWEDEN Kjell Larsson Mekwood AB Slingan 14, 812 41 Gästrike-Hammarby Tel.: +46-290-515-65 Kjell Larsson GSM: +46-706-797-965 e-mail: kjell.larsson@mekwood.se</p>	<p>IRELAND Wood-Mizer Ireland Stephen Brennan Cum Lahardane Ballina County Mayo Tel:+353 96 51345 E-mail: brennanmill@ericom.net</p>
<p>Subagents: DENMARK Kevin Christiansen Kevin Christiansen's savværker PMV Arnborgvej 40, 7330 Brande- Fasterholt Mobile: +45 61468763 Mobile: +45-23495828 Info@woodmizer.dk www.woodmizer.dk</p>	<p>ROMANIA Adrian Echert SC WOOD-MIZER RO SRL TRANSILVANIEI Nr. 5 Sibiu, Cisanadie 555300 Tel./Fax: : +40-369-405-433 GSM: +40-745-707-323 e-mail: aechert@woodmizer.ro</p>	<p>Regional Manager - Asia Robert Moxham Regional Direction - Asia Wood-Mizer Asia Manufacturing Co., Ltd. No.2, Gongyequ 40th Rd. Xitun District, Taichung City, 40768, Taiwan, R.O.C. TEL: +886-4-2359 3022 FAX: +886-4-2359 3205 CELL: +886-9-0568 7708 EMAIL: RMoxham@woodmizer.com www.woodmizerasia.com Skype: r.g.moxham</p>
<p>NETHERLANDS Gerlo Breukers Breukers Houtzagerij en Bosbouwmachines Hazenweg 5, 7481 PC Haaksbergen Tel: +31-535741326 Mobile: +31-620419412 info@woodmizer.nl www.woodmizer.nl</p>	<p>Subagent: ROMANIA M. Echert S.C. Echert Comprod s.r.l Str. Schitului Nr. 6, Apt.7 etajul-1 725 70 Vatra Dornei, Romania Tel./Fax: +40-230-374-235 Tel. : +40-740-35-35-74</p>	<p>Regional Manager - Africa Gavin Prowse Regional Sales Director - Africa Wood-Mizer Africa (Pty) Ltd. Unit 1, Leader Park 20 Chariot Street Stormill Ext.5 Maraisburg, Johannesburg South Africa TEL: +27 11 473 1313 FAX: +27 11 473 2005 CELL: +27 71 398 8010 EMAIL: growse@woodmizer.com www.woodmizerafrika.com Skype: gavin.prowse</p>

USA World Headquarters

Serving North & South America, Oceania, East Asia

Wood-Mizer LLC
8180 West 10th Street
Indianapolis, IN 46214

Phone: 317.271.1542 or 800.553.0182
Customer Service: 800.525.8100
Fax: 317.273.1011
Email: infocenter@woodmizer.com

Brazil Headquarters

Serving Brazil

Wood-Mizer do Brasil
Rua Dom Pedro 1, No: 205 Bairro: Sao Jose
Ivoti/RS CEP:93.900-000

Tel: +55 51 9894-6461/ +55 21 8030-3338/ +55 51 3563-4784
Email: info@woodmizer.com.br

Canadian Headquarters

Serving Canada

Wood-Mizer Canada
396 County Road 36, Unit B
Lindsay, ON K9V 4R3

Phone: 705.878.5255 or 877.357.3373
Fax: 705.878.5355
Email: ContactCanada@woodmizer.com

Europe Headquarters

Serving Europe, Africa, West Asia

Wood-Mizer Industries Sp z o.o.
Nagorna 114
62-600 Kolo, Poland

Phone: +48.63.26.26.000
Fax: +48.63.27.22.327

Branches & Authorized Sales Centers

For a complete list of dealers, visit www.woodmizer.com

SECTION 1 SAFETY & GENERAL INFORMATION



This symbol calls your attention to instructions concerning your personal safety. Be sure to observe and follow these instructions. This symbol accompanies a signal word. The word **DANGER** indicates an imminently hazardous situation which, if not avoided, will result in death or serious injury. **WARNING** suggests a potentially hazardous situation which, if not avoided, could result in death or serious injury. **CAUTION** refers to potentially hazardous situations which, if not avoided, may result in minor or moderate injury to persons or equipment. Read all safety instructions before operating this equipment and observe all safety warnings!



Warning stripes are placed on areas where a single decal would be insufficient. To avoid serious injury, keep out of the path of any equipment marked with warning stripes.

Read and observe all safety instructions before operating this equipment! Also read any additional manufacturer's manuals and observe any applicable safety instructions including dangers, warnings, and cautions.

Always be sure that all safety decals are clean and readable. Replace all damaged safety decals to prevent personal injury or damage to the equipment. Contact your local distributor, or call your Customer Service Representative to order more decals.

IMPORTANT! It is always the owner's responsibility to comply with all applicable federal, state and local laws, rules and regulations regarding the ownership and operation of your Wood-Mizer sawmill. All Wood-Mizer mill owners are encouraged to become thoroughly familiar with these applicable laws and comply with them fully while using the mill.

Always properly dispose of all sawing by-products, including sawdust and other debris, coolant, oil, fuel, oil filters and fuel filters.

Safety instructions are listed in this section by the following operations:

- Blade Handling
- Sawmill Setup
- Sawmill Operation
- Sawmill Maintenance

1.1 Blade Handling



DANGER! Always disengage the blade and shut off the sawmill engine before changing the blade. Failure to do so will result in serious injury.



WARNING! Always wear gloves and eye protection when handling bandsaw blades. Changing blades is safest when done by one person! Keep all other persons away from area when coiling, carrying or changing a blade. Failure to do so may result in serious injury.

1.2 Sawmill Setup



WARNING! Do not set up the mill on ground with more than a 10 degree incline. If setup on an incline is necessary, put blocks under one side of the mill or dig out areas for the legs to keep mill level. Setting up the mill on an incline could cause it to tip over, resulting in serious personal injury.

WARNING! Keep all persons out of the path of the saw head while loading and unloading the sawmill. Failure to do so may result in serious injury or death.

1.3 Sawmill Operation



IMPORTANT! The sawmill is intended for sawing wood only. [See Section Cutting Capacity](#) for log size capacities of the machine.

IMPORTANT! The operator of the sawmill should get adequate training in the operation and adjustment of the machine.



DANGER! Make sure all guards and covers are in place and secured before operating or towing the sawmill. Failure to do so may result in serious injury.

DANGER! Be sure the blade housing and pulley covers are in place and secured.

DANGER! Always keep hands away from moving bandsaw blade. Failure to do so will result in serious injury.

DANGER! Keep all persons out of the path of moving equipment and logs when operating sawmill or loading and turning logs. Failure to do so will result in serious injury.

DANGER! Maintain a clean and clear path for all necessary movement around the mill and lumber stacking areas. Failure to do so will result in serious injury.

DANGER! Always be sure the blade is disengaged and all persons are out of the path of the blade before starting the engine or motor. Failure to do so will result in serious injury.



WARNING! Always disengage the clutch/brake mechanism whenever the sawmill is not cutting. Failure to do so may result in serious injury.

WARNING! Always wear eye, ear, respiration, and foot protection when operating the sawmill. Failure to do so may result in serious injury.



WARNING! Secure all loose clothing and jewelry before operating the sawmill. Failure to do so may result in serious injury or death.

WARNING! Always make sure log is clamped securely before sawing. Failure to do so may result in serious injury or death.

WARNING! Use **ONLY** water with the water lube accessory. Never use flammable fuels or liquids. If these types of liquids are necessary to clean the blade, remove it and clean with a rag. Failure to do so may result in serious injury or death.



CAUTION! Be sure the log clamps are all the way down before loading a log onto the bed. Failure to do so may result in machine damage.

CAUTION! Before loading a log, be sure the cutting head is moved far enough forward so the log does not hit it. Failure to do so may result in machine damage.

CAUTION! Do not try to force the saw head beyond its upper and lower travel limits. Damage to the up/down system may result.

CAUTION! Be sure to stop the blade when returning the carriage. This will not only prevent the blade from being pulled off and ruined by a wood sliver, but also will increase the life of the blade.



CAUTION! Never clean the blade or the blade wheels with a brush or a scraper during sawmill operation.

CAUTION! Before installation of the blade, inspect it for damage and cracks. Use only properly sharpened blades. Always handle the blade with extreme caution. Use suitable carrier equipment for transporting the blades.

CAUTION! The blade should be replaced every two hours of sawmill operation.

CAUTION! Always wear gloves when handling the blade. Never grab the blade with bare hands!

CAUTION! If the blade breaks during sawmill operation, push the EMERGENCY STOP button to stop the blade engine and wait 10 seconds before opening the blade housing cover.

CAUTION! The sawmill's work-stand should be equipped with a 4 kg or bigger dry powder extinguisher.

1.4 Sawmill Maintenance

CAUTION! Reinstall the track wiper so that it lightly touches the track bar. If the wiper presses too firmly against the bar, it can cause the power feed to bind.

CAUTION! Never use grease on the mast rails as it will collect sawdust.

Always be sure that all safety decals are clean and readable. Replace all damaged safety decals to prevent personal injury or damage to the equipment. Contact your local distributor, or call your Customer Service Representative to order more decals.

1.5 Safety Instructions



IMPORTANT! The sawmill is intended for sawing wood only. The sawmill must not be used for other purposes such as cutting ice, metal or any other materials. [See Section 5.2](#) for log size capacities of the machine.

IMPORTANT! The operator of the sawmill should get adequate training in the operation and adjustment of the machine.

NOTE: ONLY safety instructions regarding personal injury are listed in this section. Caution statements regarding only equipment damage appear where applicable throughout the manual.

Observe Safety Instructions



IMPORTANT! Read the entire Operator's Manual before operating the sawmill. Take notice of all safety warnings throughout this manual and those posted on the machine. Keep this manual with this machine at all times, regardless of ownership.

Also read any additional manufacturer's manuals and observe any applicable safety instructions including dangers, warnings, and cautions.

Only adult persons who have read and understood the entire operator's manual should operate the sawmill. The sawmill is not intended for use by or around children.

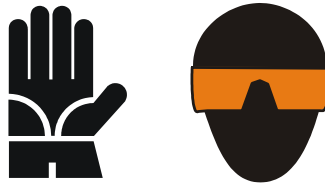
IMPORTANT! It is always the owner's responsibility to comply with all applicable federal, state and local laws, rules and regulations regarding the ownership and operation of your Wood-Mizer sawmill. All Wood-Mizer sawmill owners are encouraged to become thoroughly familiar with these applicable laws and comply with them fully while using the machine.



Wear Safety Clothing

WARNING! Secure all loose clothing and jewelry before operating the sawmill. Failure to do so may result in serious injury or death.

WARNING! Always wear gloves and eye protection when handling bandsaw blades. Changing blades is safest when done by one person! Keep all other persons away from area when coiling, carrying or changing a blade. Failure to do so may result in serious injury.



WARNING! Always wear eye, ear, respiration, and foot protection when operating or servicing the sawmill.

***Keep sawmill And Area Around sawmill Clean***

DANGER! Maintain a clean and clear path for all necessary movement around the sawmill and lumber stacking areas. Failure to do so will result in serious injury.

Dispose Of Sawing By-Products Properly

IMPORTANT! Always properly dispose of all sawing by-products, including sawdust and other debris.

Check sawmill Before Operation



DANGER! Make sure all guards and covers are in place and secured before operating the sawmill. Failure to do so may result in serious injury.



Keep Persons Away



DANGER! Keep all persons out of the path of moving equipment and lumber when operating the sawmill. Failure to do so will result in serious injury.

DANGER! Always be sure all persons are out of the path of the blade before starting the motor. Failure to do so will result in serious injury.



WARNING! Allow blade to come to a complete stop before opening the blade housing cover. Failure to do so will result in serious injury.

Keep Hands Away

DANGER! Always shut off the blade motor before changing the blade. Failure to do so will result in serious injury.

DANGER! Motor components can become very hot during operation. Avoid contact with any part of a hot motor. Contact with hot motor components can cause serious burns. Therefore, never touch or perform service functions on a hot motor. Allow the motor to cool sufficiently before beginning any service function.

DANGER! Always keep hands away from moving bandsaw blade. Failure to do so will result in serious injury.

DANGER! Always be aware of and take proper protective measures against rotating shafts, pulleys, fans, etc. Always stay a safe distance from rotating members and make sure that loose clothing or long hair does not engage rotating members resulting in possible injury.



WARNING! Use extreme caution when spinning the blade wheels by hand. Make sure hands are clear of blade and wheel spokes before spinning. Failure to do so may result in serious injury.

Use Proper Maintenance Procedures



DANGER! Make sure all electrical installation, service and/or maintenance work is performed by a qualified electrician and is in accordance with applicable electrical codes.

DANGER! Hazardous voltage inside the electric boxes and at the motor can cause shock, burns, or death. Disconnect and lock out power supply before servicing! Keep all electrical component covers closed and securely fastened during sawmill operation.



WARNING! Consider all electrical circuits energized and dangerous.

WARNING! Disconnect and lock out power supply before servicing the sawmill! Failure to do so may result in serious injury.

WARNING! Never assume or take the word of another person that the power is off; check it out and lock it out.

WARNING! Do not wear rings, watches, or other jewelry while working around an open electrical circuit.

WARNING! Remove the blade before performing any service to the motor or sawmill. Failure to do so may result in serious injury.

DANGER! Never clean the blade or blade wheels using the hand-held brush or scraper whilst the sawmill blade is in motion.

CAUTION! Before installation of the blade, inspect it for damage and cracks. Use only properly sharpened blades. Always handle the blade with extreme caution. Use suitable carrier equipment for transporting the blades.

CAUTION! Always wear gloves when handling the blade. Never grab the blade with bare hands!

CAUTION! If the blade breaks during sawmill operation, push the EMERGENCY STOP button to stop the blade motor and wait 10 seconds before you open the blade housing cover.

CAUTION! The sawmill's work-stand should be equipped with a 4 kg or bigger dry powder extinguisher.

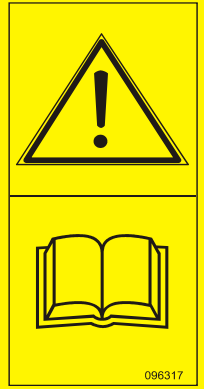

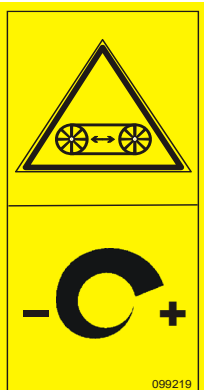
Keep Safety Labels In Good Condition

IMPORTANT! Always be sure that all safety decals are clean and readable. Replace all damaged safety decals to prevent personal injury or damage to the equipment. Contact your local distributor, or call your Customer Service Representative to order more decals.

IMPORTANT! If replacing a component which has a safety decal affixed to it, make sure the new component also has the safety decal affixed.

See Table 1-1. Pictogram decals used to warn and inform the user about danger in the LT15.

TABLE 1-1

Decal View	W-M No.	Description
	096317	CAUTION! Read thoroughly the manual before operating the machine. Observe all safety instructions and rules when operating the sawmill.
	099220	CAUTION! Close all guards and covers before starting the machine.
	099219	Blade tension. Turning the bolt clockwise will increase the blade tension and turning the bolt counterclockwise will decrease the tension.

1

Safety & General Information

Keep Safety Labels In Good Condition

TABLE 1-1

<p>099221</p>	<p>099221</p>	<p>CAUTION! Keep all persons a safe distance away from work area when operating the machine.</p>
<p>086099</p>	<p>086099</p>	<p>CAUTION! Hot elements, keep your distance!</p>
<p>098176</p>	<p>098176</p>	<p>CAUTION! Keep away from debarker blade!</p>
<p>096321</p>	<p>096321</p>	<p>Blade movement direction</p>

TABLE 1-1





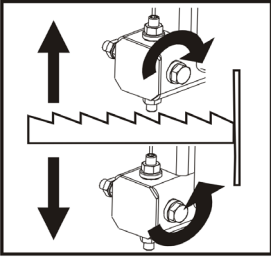
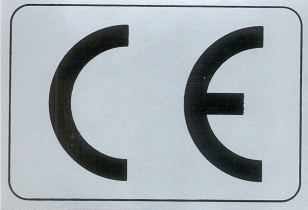


 <p>A blue circular icon with a white silhouette of a person wearing safety goggles. The text 'S12004G' is printed in the bottom right corner of the circle.</p>	<p>S12004G</p>	<p>CAUTION! Always wear safety goggles when operating the sawmill!</p>
 <p>A blue circular icon with a white silhouette of a person wearing protective ear muffs. The text 'S12005G' is printed in the bottom right corner of the circle.</p>	<p>S12005G</p>	<p>CAUTION! Always wear protective ear muffs when operating the sawmill!</p>
 <p>A blue circular icon with a white silhouette of a safety boot.</p>	<p>501465</p>	<p>CAUTION! Always wear safety boots when operating the sawmill.</p>
 <p>A red circular icon with a black silhouette of a hand using a tool to apply lubrication to a point.</p>	<p>501467</p>	<p>Lubrication point</p>
 <p>A technical diagram showing two views of a saw blade being aligned on wheels. The top view shows the blade being moved up (indicated by an upward arrow) and rotated (indicated by a curved arrow). The bottom view shows the blade being moved down (indicated by a downward arrow) and rotated (indicated by a curved arrow). The text 'P11789b' is printed at the bottom of the diagram.</p>	<p>P11789/PL</p>	<p>Aligning the blade on the wheels</p>

TABLE 1-1

<table border="1"> <thead> <tr> <th rowspan="2">Type</th> <th colspan="2"></th> <th rowspan="2">psi</th> <th rowspan="2">bar</th> </tr> <tr> <th>F[mm]</th> <th>E[mm]</th> </tr> </thead> <tbody> <tr> <td>275</td> <td>1,07</td> <td>32</td> <td>1015-1088</td> <td>70-75</td> </tr> <tr> <td>375</td> <td>1,14</td> <td>32</td> <td>1088-1160</td> <td>75-80</td> </tr> <tr> <td>2735</td> <td>1,07</td> <td>35</td> <td>1160-1233</td> <td>80-85</td> </tr> </tbody> </table>	Type			psi	bar	F[mm]	E[mm]	275	1,07	32	1015-1088	70-75	375	1,14	32	1088-1160	75-80	2735	1,07	35	1160-1233	80-85	510643	Setting the blade tension indicator
Type						psi	bar																	
	F[mm]	E[mm]																						
275	1,07	32	1015-1088	70-75																				
375	1,14	32	1088-1160	75-80																				
2735	1,07	35	1160-1233	80-85																				
	P85070	CE safety certification																						
	099401	Russian safety certification																						
	S20097A	3600 RPM - engine rotation direction																						

1.6 Belt Sizes

See Table 1-2. Belt sizes for the LT15 sawmill are shown below.

Description	Belt Size	Wood-Mizer Part #
Engine Drive Belt (G18, D10)	BX87	097448
Blade Pulley Belts	B57 ¹	P04185

TABLE 1-2

¹ To insure proper blade tracking, use Goodyear, Dayco Super II, or Browning belts only.

1.7 Blade Sizes

See Table 1-3. Wood-Mizer TRU•SHARP™ offers three types of blades to provide efficient sawing for all models of sawmills. The engine/motor size of your sawmill and the type of wood you saw should determine which blade you choose for optimum performance.

Engine/Motor Size	Recommended Blade For Sawing ¹ :		
	Softwood	Hardwood	Frozen or Hard-to-Cut Wood
5 hp - 15hp	B275IH1030 B275IH741030	B375IH929	B375IH929 ²
16hp or more	B376IH1030 B376IH741030	B275IH1030 B275IH741030 B376IH1030 B376IH741030 ³	B375IH929 ²
Electric Motor	B376IH1030 B376IH741030	B275IH1030 B275IH741030 B376IH1030 B376IH741030 ³	B375IH929 ²

TABLE 1-3

¹ The LT15 sawmill is equipped with a blade having a length of 4.01 m.

² TRU•SHARP™ “F” blades use a 9/29 profile (9° hook angle and 29° back angle) and are designed to cut frozen and/or extremely dense, hard-to-cut wood. Standard TRU•SHARP™ blades use a 10/30 profile.

³ Customer may choose preferred blade.

See *The Blade Handbook* for blade hook angle, tooth height, and tooth set specifications.

1.8 Cutting Capacity

See Table 1-4. The log size capacities of the LT15 sawmills are listed below.

	Max. Diameter	Max. Length ¹
LT15 S3	70 cm	5.4 m
LT15 S2	70 cm	3.5 m
LT15 M2	70 cm	5.2 m
LT15 M3	70 cm	7.9 m

TABLE 1-4

¹ Each additional bed frame segment adds approximately 195 cm (6' 5") to the length capacity.

1.9 Engine/Motor Specifications

See Table 1-5. The power options available for the LT15 sawmill are listed below.

Engine/Motor Type	Manufacturer	Model No.	Specifications
18HP Gasoline	Kohler	CH18	624 ccm, 3600 min ⁻¹
10HP Diesel Engine	Yanmar, Japan	L100	406 ccm, 3600 min ⁻¹

TABLE 1-5

1.10 Noise Level

See Table 1-6. The average level of noise is given in the table below¹².

Sawmill	Noise Level
LT15E11	81,9 dB (A)
LT15G18	89,7 dB (A)
LT15D10	87,0 dB (A)

TABLE 1-6

1. The noise level measurement was taken in accordance with PN-EN ISO 3746 Standard. The noise exposure level given above concerns an 8-hour work day. Value for associated uncertainty K=4dB.

2. The figures quoted are emission levels and are not necessarily safe working levels. Whilst there is a correlation between the emission and exposure levels, this cannot be used reliably to determine whether or not further precautions are required. Factors that influence the actual level of exposure of the workforce include the characteristics of the work room and the other sources of noise etc. i.e. the number of machines and other adjacent processes. Also the permissible exposure level can vary from country to country. This information, however, will enable the user of the machine to make a better evaluation of the hazard and risk.

1.11 Dust Extractor Specifications

See Table 1-1. Specifications of the dust extractors used on the resaw for each saw head are listed below.¹

Airflow	1200 m ³ /h 3937ft ³ /h
Inlet diameter	100 mm (5.9")
Motor power	1.5 kW
Number of sacks	1 pc
Sack capacity	0,25 m ³ (8.8 ft) ³
Weight	110 kg (242.5 lb)
Pressure drop	1,5 kPa (0.22 psi) ¹
Recommended conveying air velocity in the duct	20 m/s 65.6 ft/s

TABLE 1-1

¹ The pressure drop between the inlet of the capture device and the connection to the CADES should be maximum 1,5 kPa (for the nominal air flow rate). If the pressure drop exceeds 1.5 kPa the machine might not be compatible with conventional CADES.



IMPORTANT! The dust extractor hoses must be grounded or made with materials not accumulating electrostatic charge.



CAUTION! Always turn on the dust extractor before starting the machine



IMPORTANT! The total value of hand-arm vibration the operator may be exposed to does not exceed 2.5 m/s². The highest root mean square value of weighted acceleration to which the whole operator's body is subjected does not exceed 0.5 m/s².

1. External chip and dust extraction equipment with fixed installations are dealt with in EN 12779:2016-04.

1.12 Overall Dimensions

See Figure 1-2. The overall dimensions of the LT15 sawmills are shown below.

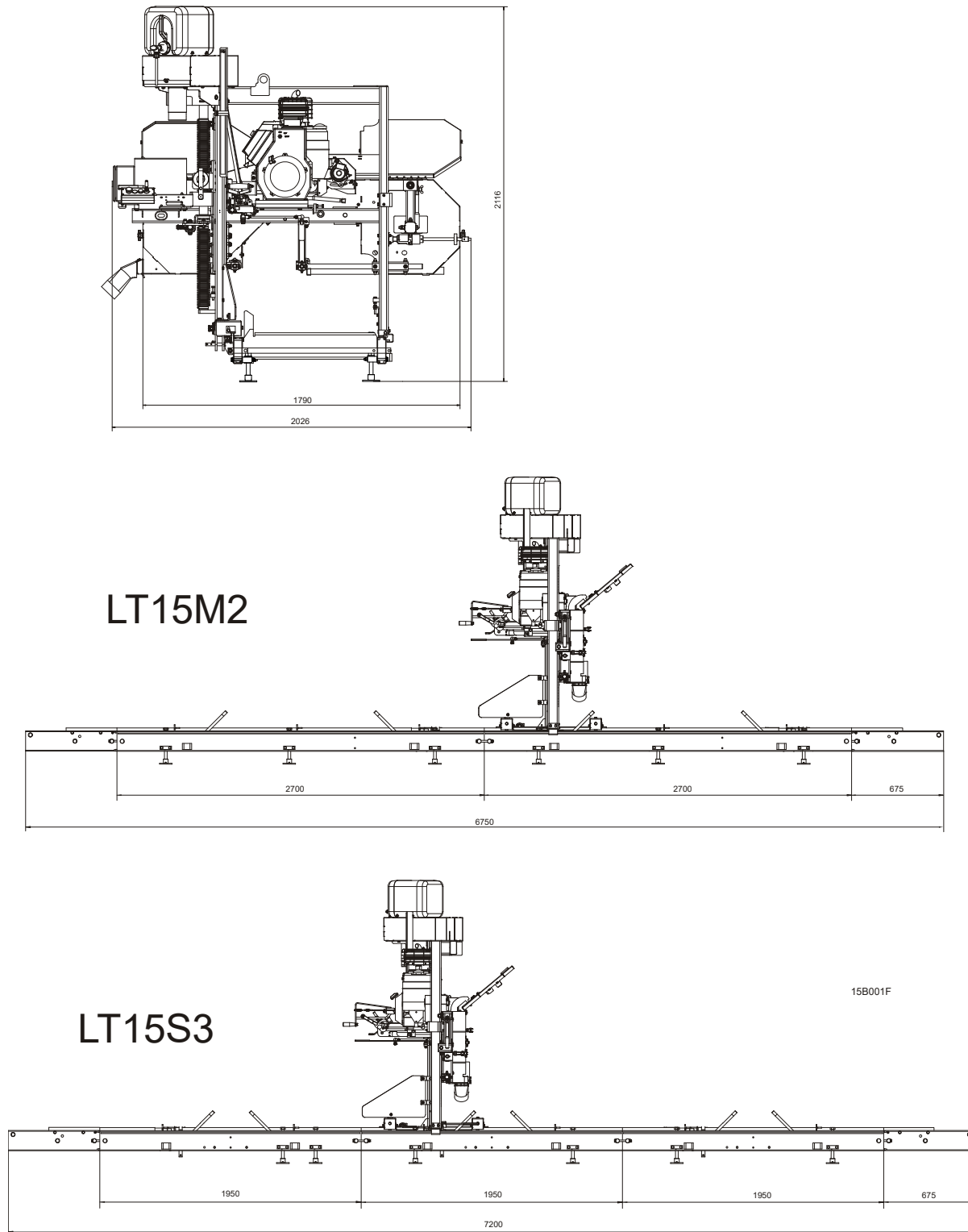


FIG. 1-1

See Figure 1-3. The picture below shows the operator's position.

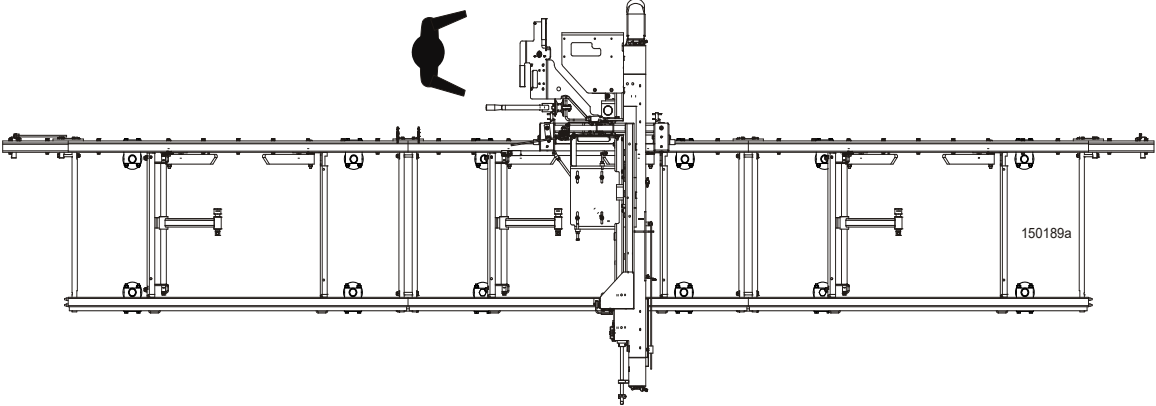


FIG. 1-2

1.13 Components

The major components of the Wood-Mizer LT15G18 are shown below.

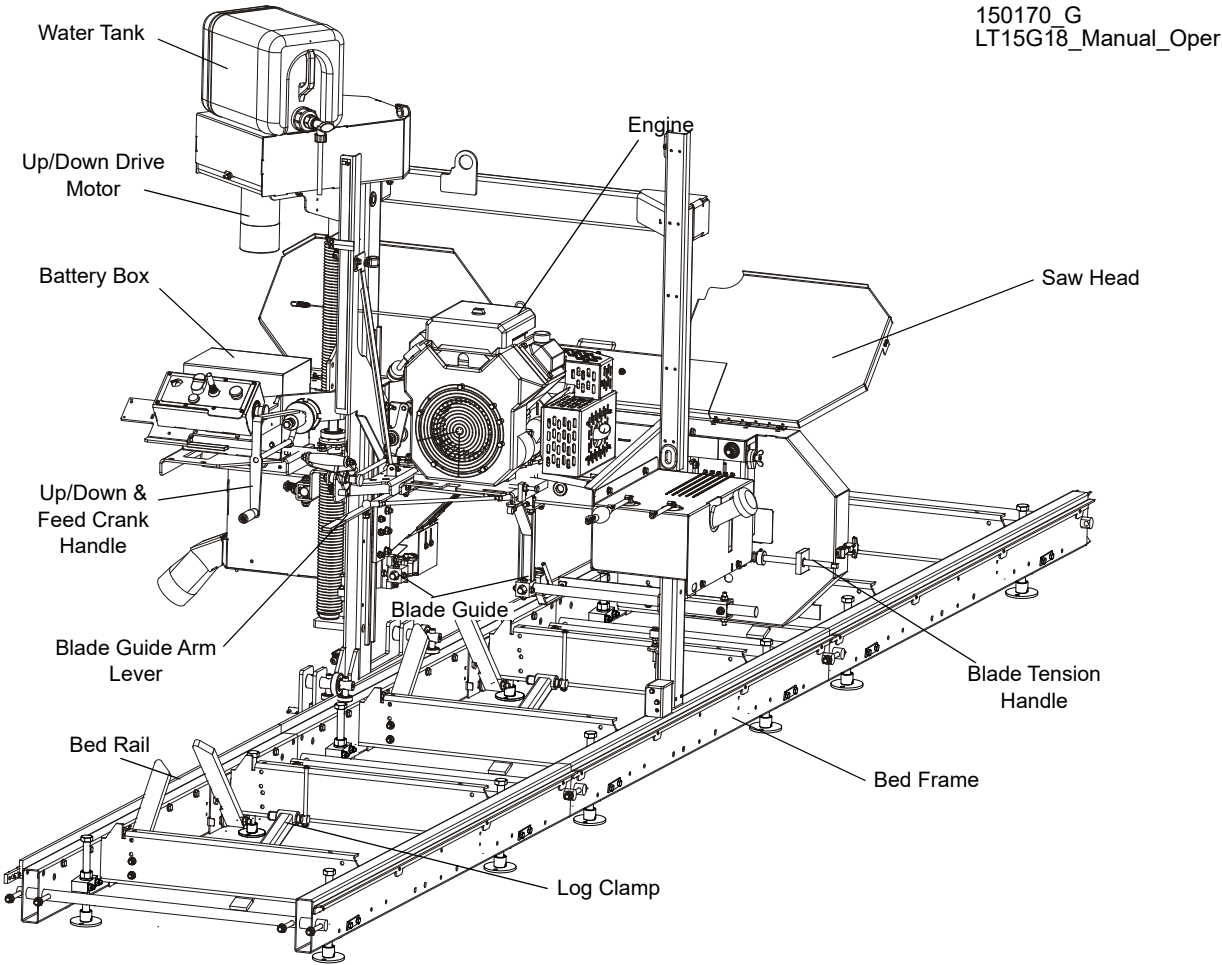


FIG. 1-3

SECTION 2 SAWMILL ASSEMBLY

2.1 Mounting Parts of LT15 Sawmills with Gas Engine

2.1.1 Parts Specifications

Scan to see the assembly video



Table 1:

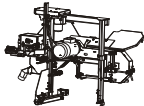
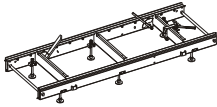
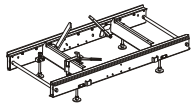
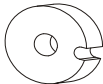
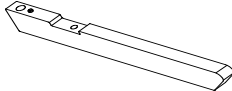
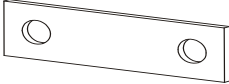
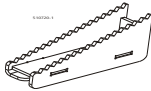
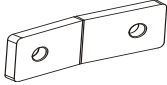
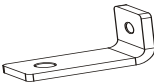

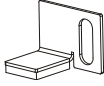
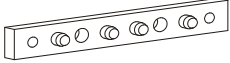
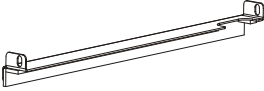

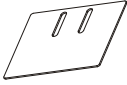


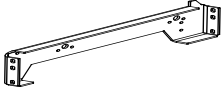
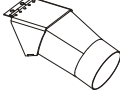
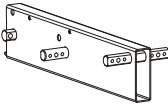
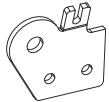
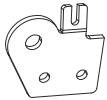
Fig.	Wood-Mizer Part No.	Description	Qty LT15 M2	Qty LT15 M3	Qty LT15 S2	Qty LT15 S3/S3-P		Qty LT15 S4/S4-P	
						LT15 S3	LT15 S3-P	LT15 S4	LT15 S4-P
	095250	LT15DC Sawmill Saw Head	1	1	1	1	1	1	1
	094697	LT15 Bed Section, Complete (2.75 m)	2	3	--	--	--	--	--
	094514	LT15 Bed Section, Complete (1.95 m)	--	--	2	3	3	4	4
	085981-1	Thick Spacer Washer	4	6	4	6	6	8	8
	085982-1	Log Side Support, Complete	4	6	4	6	6	8	8
	085994-1	Bed Leg Mounting Washer, Painted	12	18	8	12	12	16	16
	510720-1	Leveling Wedge, Painted	1	1	1	1	1	1	1
	086171-1	Side Bracket	2	2	2	2	2	2	2
	086172-1	Bottom Bracket	1	1	1	1	1	1	1

Table 1:

	086322	Right Track Wiper	2	2	2	2	2	2	2
	086323	Left Track Wiper	2	2	2	2	2	2	2
	086659-1	Frame Mounting Strap, Zinc-plated	3	4	2	3	3	4	4
	086745	Middle Track Cover with Felt Wiper	1	1	1	1	--	1	--
	092378-1	Bracket, Blade Guide Roller Guard	1	--	--	--	--	--	--
	092379-1	Blade Guide Roller Guard	1	--	--	--	--	--	--
	093859	Plate, PC Guard	1	1	1	1	--	1	--
	094250-1	Track Rail, Zinc-plated (Short)	2	2	2	2	2	2	2
	095490-1	Auxiliary Bed Rail	1	1	1	1	1	1	1
	100903-1	Sawdust Chute	1	1	1	1	1	--	--
	500844-1	Bed Extension Tube, Painted	2	2	2	2	2	2	2
	550623-1	Feed Rope Mount Front Bracket	1	1	1	1	--	1	--
	550624-1	Feed Rope Mount Rear Bracket	1	1	1	1	--	1	--

2 SAWMILL ASSEMBLY

Parts Specifications

Table 1:

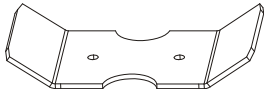
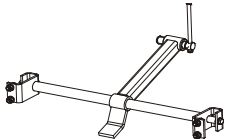
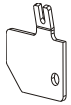

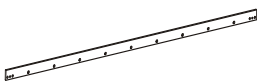
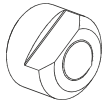


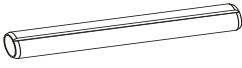
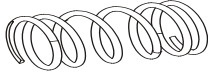
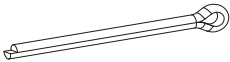

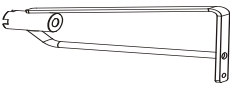
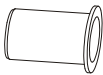
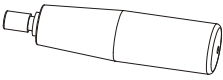



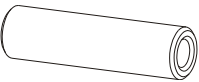


	506287-1	Plate, LT15 Bed Section Connector	8	12	8	12	12	16	16
	507565	Log Clamp	2	3	2	3	3	4	4
	508236-1	Feed Rope Mount Front Bracket (LT15-EC)	--	--	--	1	--	--	--
	508237-1	Feed Rope Mount Rear Bracket (LT15-EC)	--	--	--	1	--	--	--
	094427-1 (LT15S3) 094696-1 (LT15M2)	Track Rail	2	3	2	3	3	4	4
	LTBGAT	Tool, Blade, Guide, Alignment	--	--	--		--	--	--
	R02080	Rope	8,7	11	7	9	--	12	--
	T00414	Clamp Cap	2	3	2	3	3	4	4
Vertical Mast Lock Assembly									
	086743-1	Zinc-plated Pin	2	2	2	2	2	2	2
	F81045-1	Roll Pin 6x50	2	2	2	2	--	2	--
	F81044-21	Roll Pin 3x20	2	2	2	2	--	2	--
	087301	Compression Spring 18x37x1.8	2	2	2	2	2	2	2

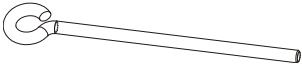
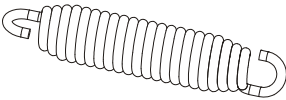
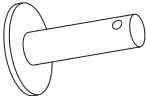
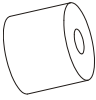
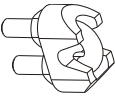


Table 1:

	F81043-2	Cotter Pin S-Zn 4x25	2	2	2	2	2	2	2
	F81058-1	Flat Washer 17	2	2	2	2	--	2	--
Manual Feed Assembly									
	538949-1	Power Feed Crank Handle	1	1	1	1	--	--	--
	094142	Bushing	2	2	2	2	--	--	--
	086338	Crank Handle Grip	1	1	1	1	--	--	--
	F81033-1	M10 Hex Nylon Lock Nut	1	1	1	1	--	--	--
Power Feed Assembly									
	R80663	Rope	--	--	--	--	7,4	--	9,4
	500839	Track Cover w/Felt Wiper	--	--	--	--	1	--	1
	500726	Cover, LT15 Lower	--	--	--	--	1	--	1
	501417-1	Link, Power Feed System Rope	--	--	--	--	2	--	2
	501414-1	Plate, LT15 Power Feed Support	--	--	--	--	2	--	2
	500848-1	Tensioner, Short	--	--	--	--	1	--	1

2 SAWMILL ASSEMBLY

Specifications of Fasteners

Table 1:

	500846-1	Tensioner	--	--	--	--	1	--	1
	089689	Spring, Press Roller	--	--	--	--	1	--	1
	086182-1	Mount Wdmt, Carriage Stop	--	--	2	2	2	2	2
	P12165	Bushing, Rubber	--	--	2	2	2	2	2
	091614	Clamp, Rope	--	--	--	--	4	--	4
Outrigger Leg Kit									
	095745-1	Leg Mounting Block	12	18	8	12	12	16	16
	087771-1	LT15 Foot Mount Plate	12	18	8	12	12	16	16

2.1.2 Specifications of Fasteners

Table 2:

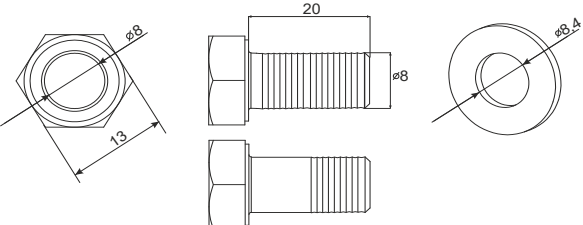
Wood-Mizer No.	Description	Qty	Qty	Qty	Qty		Qty		
		LT15 M2	LT15 M3	LT15 S2	LT15 S3	LT15 S3-P	LT15 S4	LT15 S4-P	
						LT15 S3	LT15 S3-P	LT15 S4	LT15 S4-P
<p>Sample designations of fasteners:</p> <p>M8 Nut M8x20 Bolt 8.4 Washer</p> 									
014972	33/64 x1" x 1/32 Nylon Washer	8	6	4	6	6	8	8	

Table 2:

100076-1	M10-20 Special Bolt	8	6	4	6	6	8	8
F81001-15	M6x16-8.8 Bolt	10	12	8	12	12	16	12
F81001-7	M6x12 Bolt	2	--	--	2	--	--	--
F81002-20	M8x16 Bolt	2	--	--	2	2	--	2
F81002-4	M8x20 Bolt	8	8	8	8	8	8	8
F81002-5	M8x25 Bolt	3	3	3	3	3	3	3
F81002-6	M8x12 Bolt	--	--	--	--	2	--	2
F81003-1	M10x20 Bolt	6	2	2	2	2	--	--
F81003-11	Bolt M10x25-8.8	6	8	8	8	8	12	12
F81003-15	M10x75 Bolt	34	47	27	34	34	43	43
F81003-2	M10x30 Bolt-5.8	4	4	4	4	4	4	4
F81003-2	M10x30 Bolt-8.8	--	--	--	--	4	12	4
F81003-66	M10x90 Bolt	1	1	1	1	1	1	1
F81004-12	Bolt M12-55-8.8	--	--	--	--	--	--	--
F81004-35	Bolt M12x140	4	6	6	6	6	8	8
F81004-36	M12x130 Bolt	--	--	--	6	--	--	--
F81004-38	M12x120 Bolt	8	12	8	12	12	16	16
F81031-2	M6-8-B Nut	10	12	8	12	14	16	12
F81032-2	M8 Nut	3	3	3	3	3	3	3
F81033-1	M10 Hex Nylon Lock Nut	57	82	50	57	57	75	75
F81033-3	M10 Nut	4	6	4	6	10	8	12
F81034-2	M12 Hex Nylon Lock Nut	16	22	16	20	20	26	26
F81053-1	6.4 Flat Washer	--	--	--	24	--	--	--
F81053-11	6.5 Special Flat Washer	6	--	--	6	--	--	--
F81054-1	8.4 Flat Washer	16	16	16	16	16	16	16
F81054-4	Washer, 8.4 Flat,zinc	--	--	--	--	--	--	--
F81055-1	10.5 Flat Washer	100	150	101	101	106	126	131
F81055-2	10.2 Split Lock Washer	10	12	12	12	12	16	16
F81056-1	13 Flat Washer	26	38	30	36	36	46	46
Outrigger Leg Kit								
F81003-58	M10x120 Bolt	24	36	16	24	24	32	32
F81007-1	M20x240 Bolt	12	18	8	12	12	16	16
F81037-1	M20 Nut	12	18	8	12	12	16	16
F81059-2	21 Flat Washer	12	18	8	12	12	16	16

2.1.3 Tools Necessary for Assembling the Sawmill

Table 3:

Required Tools	
Flat Wrench #8	1 pc
Flat Wrench #10	2 pcs
Flat Wrench #13	2 pcs
Flat Wrench #17	2 pcs
Flat Wrench #19	2 pcs
Ratchet Wrench #30	1 pc
Hammer	1 pc
Allen Wrench #4	1 pc
Allen Wrench #5	1 pc

2.2 Unpacking the Sawmill



1. Cut the bands holding the components together.
2. Remove the parts arranged inside the bed section.
3. Using a forklift truck or a winch with lifting capacity of minimum 500 kg, carefully lift the saw head and set it aside. Then attach the winch hook to the bracket on the saw head.



WARNING! When removing the saw head, use extreme care and keep all persons at a safe distance. Failure to do so may result in serious injury or death.

See Figure 2-1.

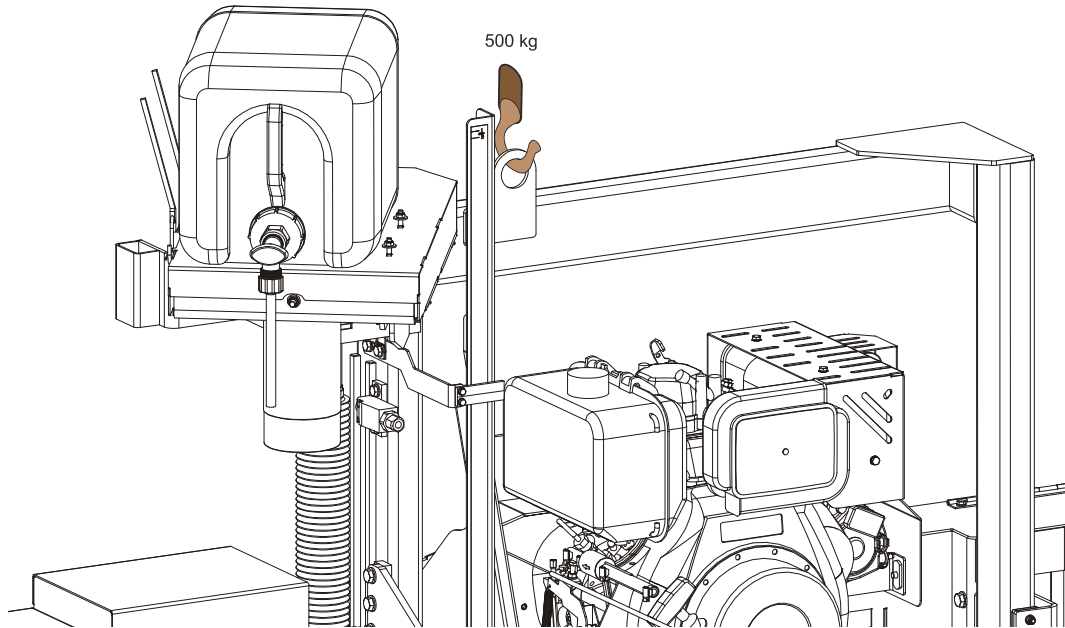


FIG. 2-1

2.3 Bed Frame Assembly

IMPORTANT! With all screw joints without split lock washer or lock nylon nut, use the "LOCTITE 243" (blue, of average durability, for screw joints).

See Figure 2-2. Mount preliminarily the track rail as shown in Figure 2-2. Do not tighten the nuts.

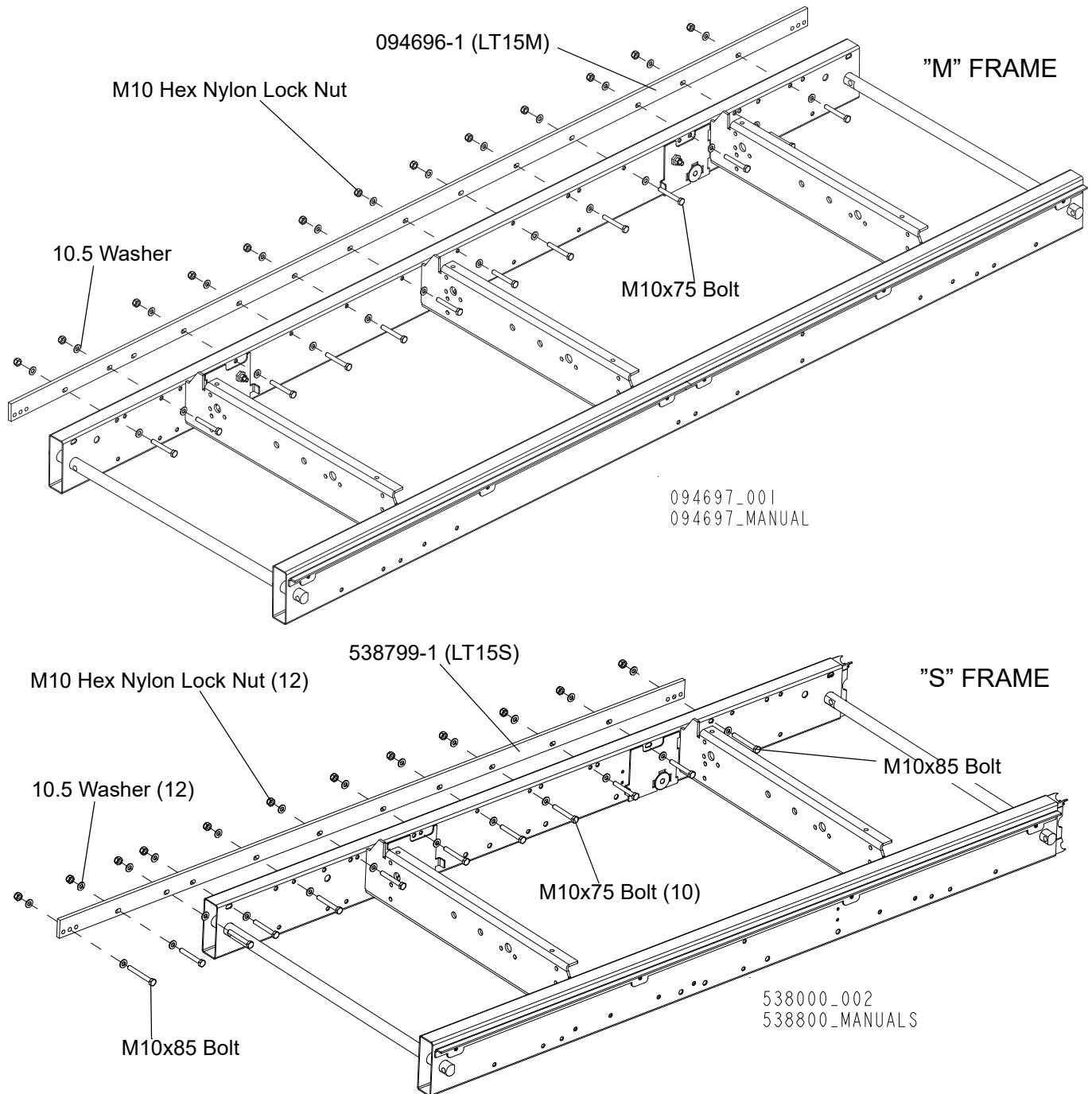


FIG. 2-2

4. **Adjustable legs:** mount four (or six) leg brackets to each bed section. Use two hex head bolts and lock nuts to secure each leg bracket to the bed section. Be sure the nut on the bracket faces up. Thread a leg into each bracket.

See Figure 2-3.

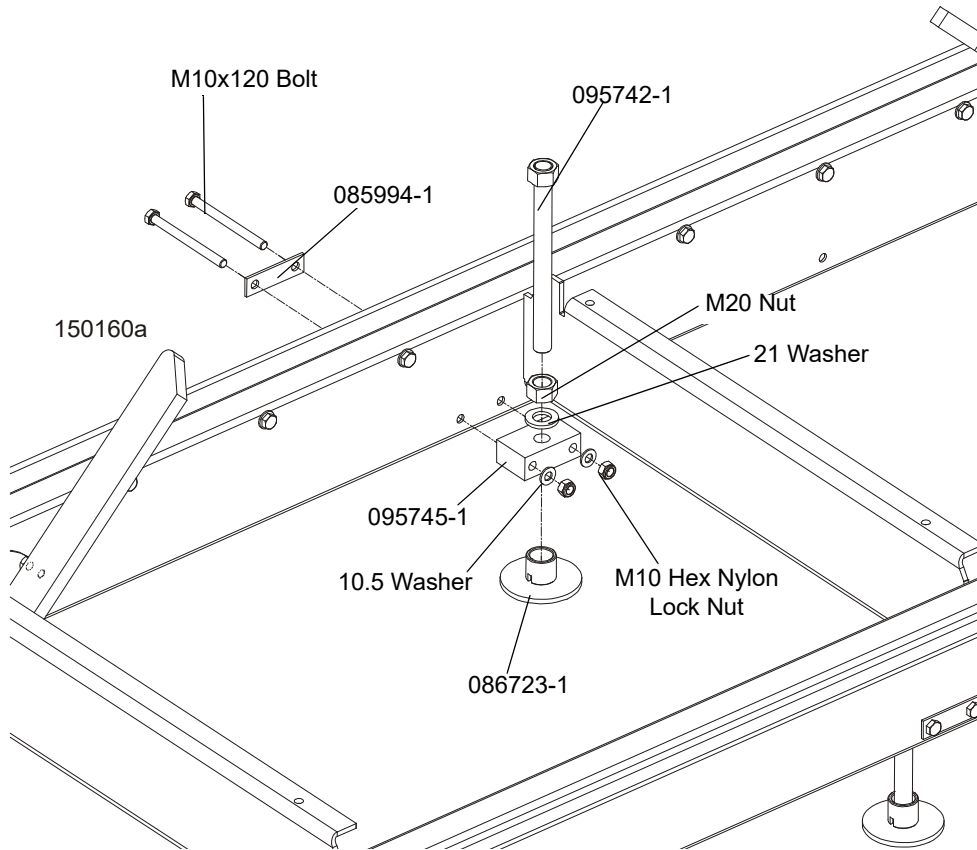


FIG. 2-3

2 SAWMILL ASSEMBLY

Bed Frame Assembly

5. **Non-adjustable legs:** mount four (or six) legs to each bed section. Use two hex head bolts and lock nuts to secure each leg to the bed section.

See Figure 2-4.

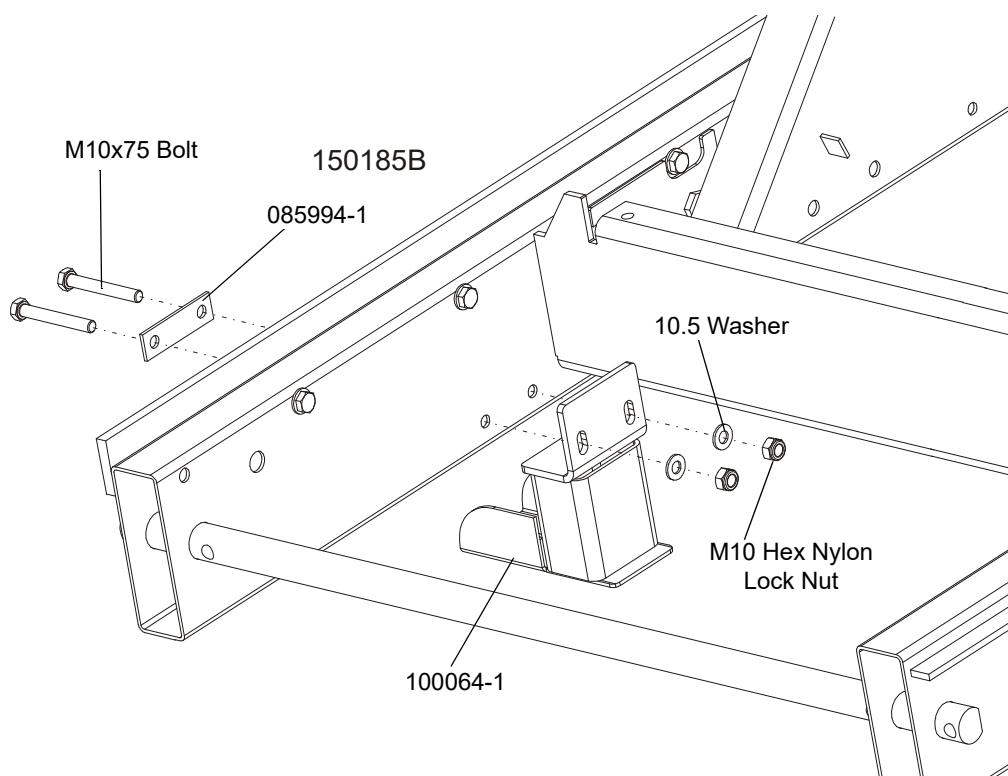


FIG. 2-4

6. Lay the frame sections end-to-end so the track portion of each section is on the same side. Slide the sections together and secure with four hex head bolts and nylon lock nuts.

See Figure 2-5.

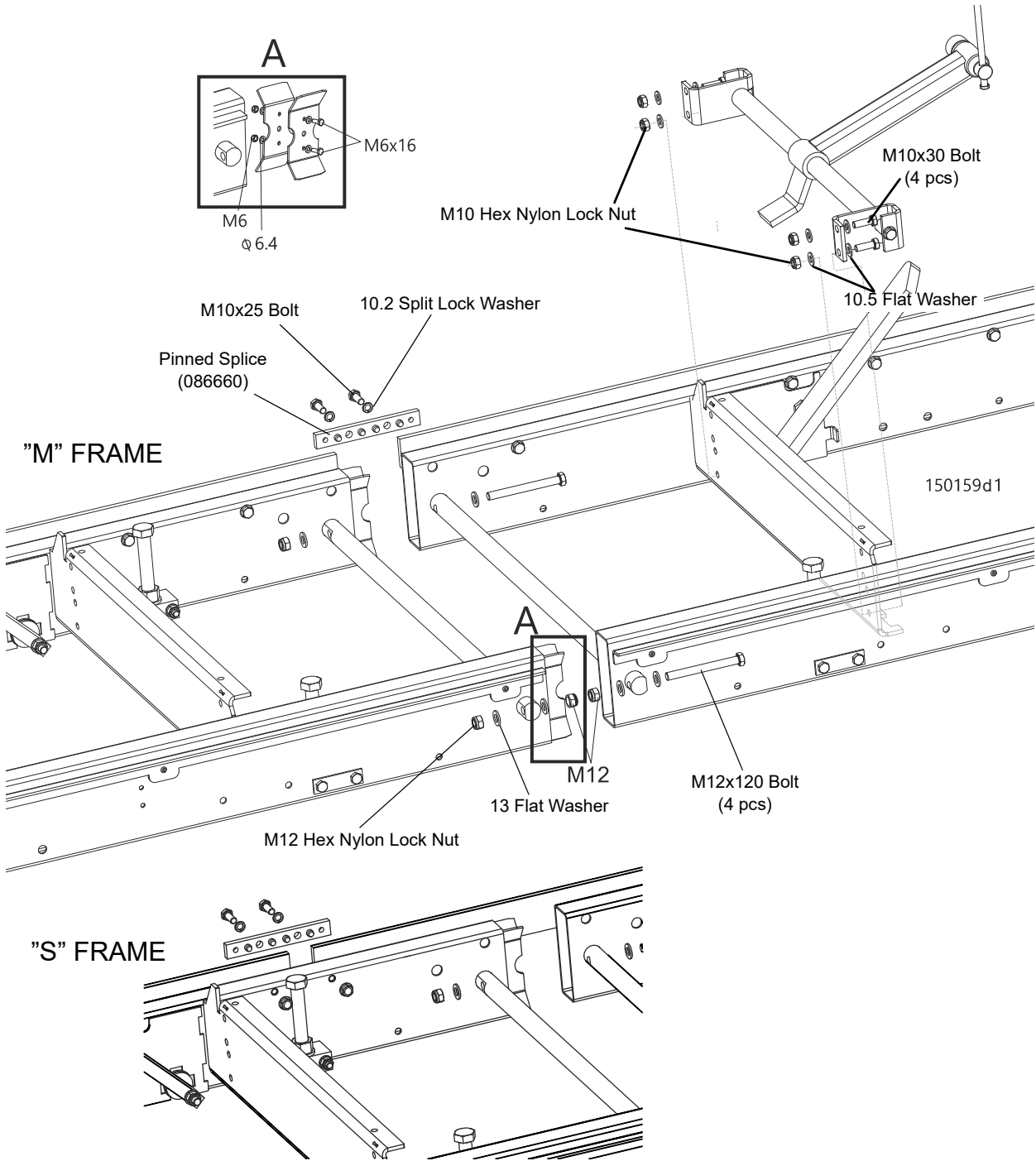


FIG. 2-5

- Fasten the track rails together using the frame mounting straps, on the outside of the frame. (See the figure above.) Secure each strap to the track rail with two hex head bolts. Tighten the track rail mounting nuts.

8. Mount a bed extension to the front and the rear ends of the bed frame.

See Figure 2-6.

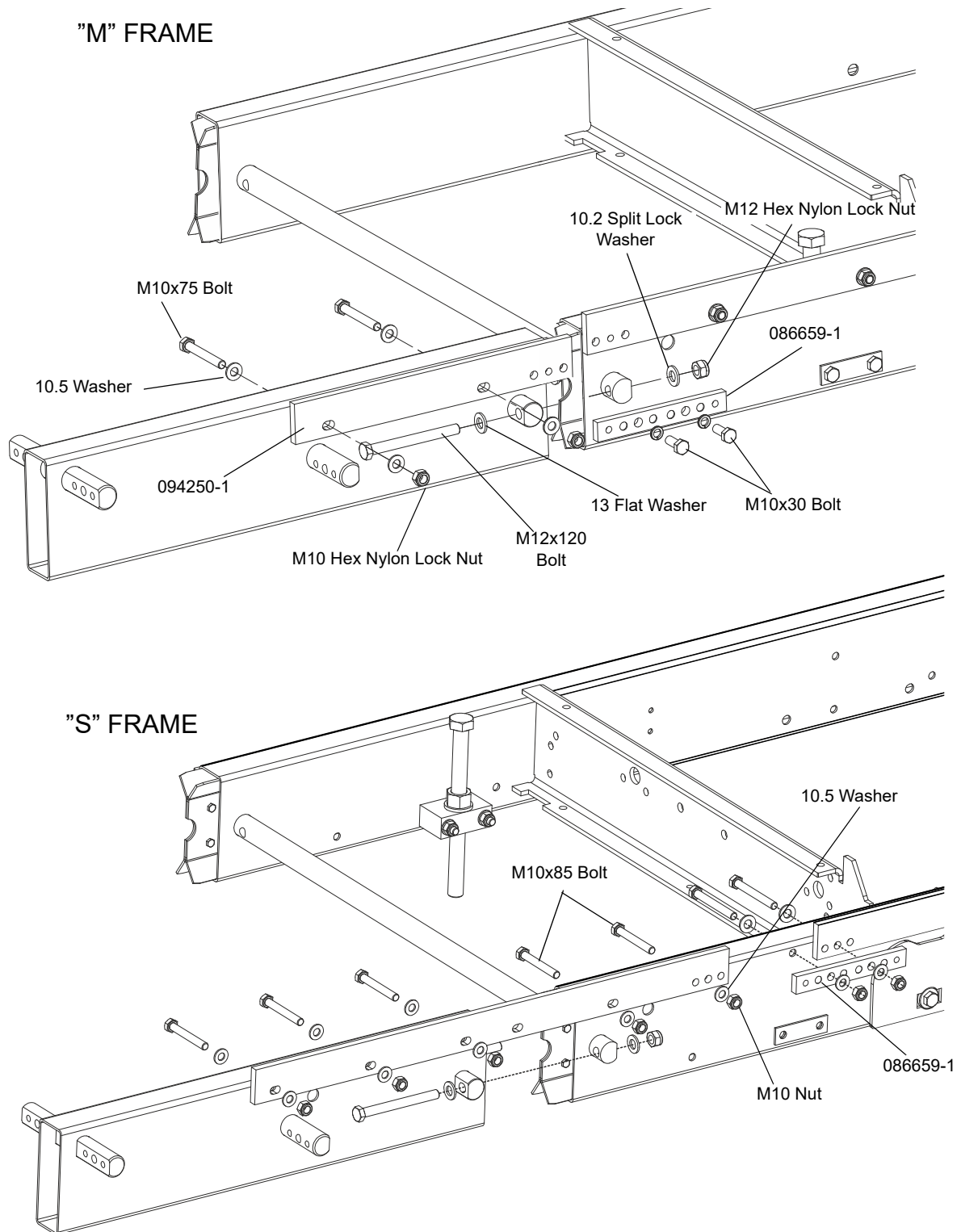


FIG. 2-6

9. Assemble a log clamp to a bed rail on each bed section using the existing hex head bolts and nylon lock nuts.
10. Install the log side supports as shown in Figure 2-7. Tighten the nuts so that the side supports can be moved with little resistance. Adjust the side supports. [See Section 6.11.](#)

See Figure 2-7.

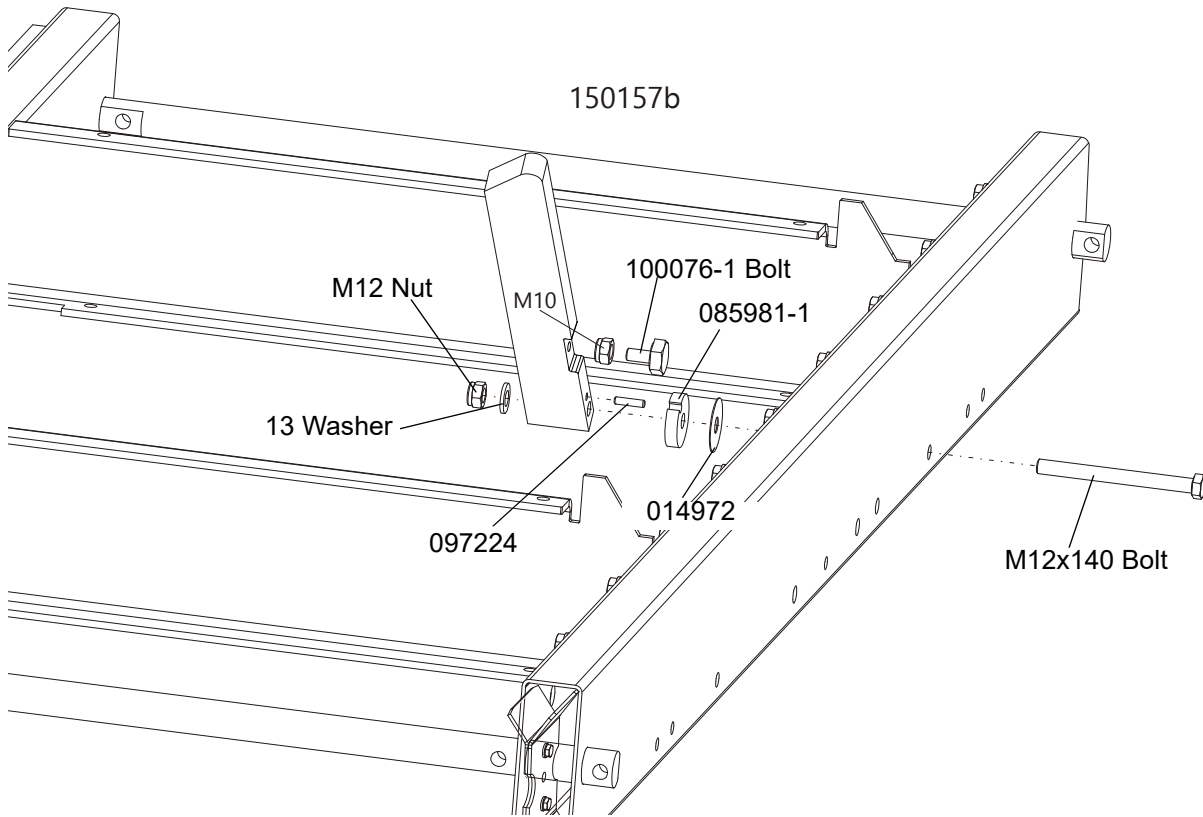


FIG. 2-7

2.4 Frame Leg Adjustment

1. Place a foot plate under each bed leg.
2. Using an appropriate wrench, adjust each leg so that the nut is approximately 25mm below the top of the bed tube

See Figure 2-8.

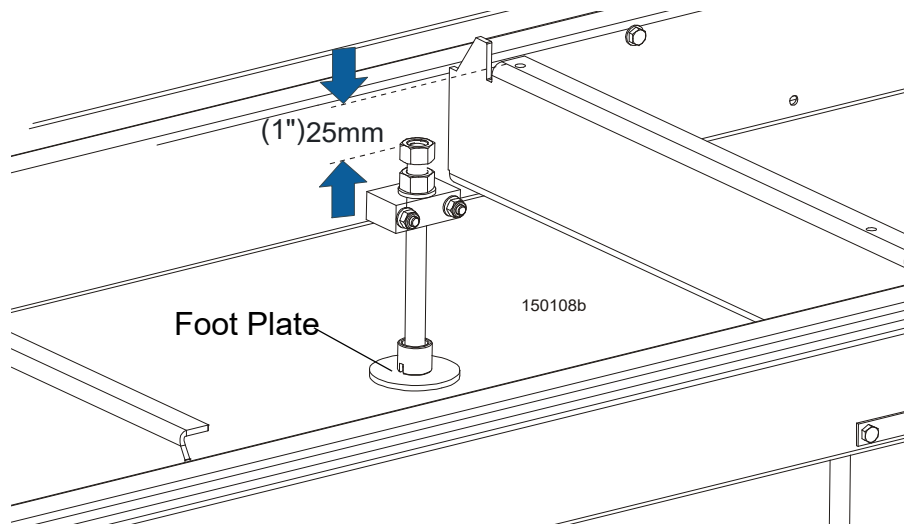


FIG. 2-8



CAUTION! The top of the leg should not be higher than the top surface of the bed rail.

2.5 Saw Head Assembly

1. Position the saw head at the end of the bed frame assembly. Carefully slide the saw head rollers onto the bed frame track. Keep the saw head square to the bed to avoid putting the track rollers in a bind.



WARNING! When setting the saw head on the bed frame, use extreme care and keep all persons at a safe distance. Failure to do so may result in serious injury or death.

2. Position the middle track cover between the two track roller housings so the opening in the cover is positioned over the feed rope pulleys. Secure with two hex head bolts and lock washers.
3. Install a track wiper with a felt strip to each track roller housing using a 8.4 flat washer and M8x12 hex head bolt.

See Figure 2-9.

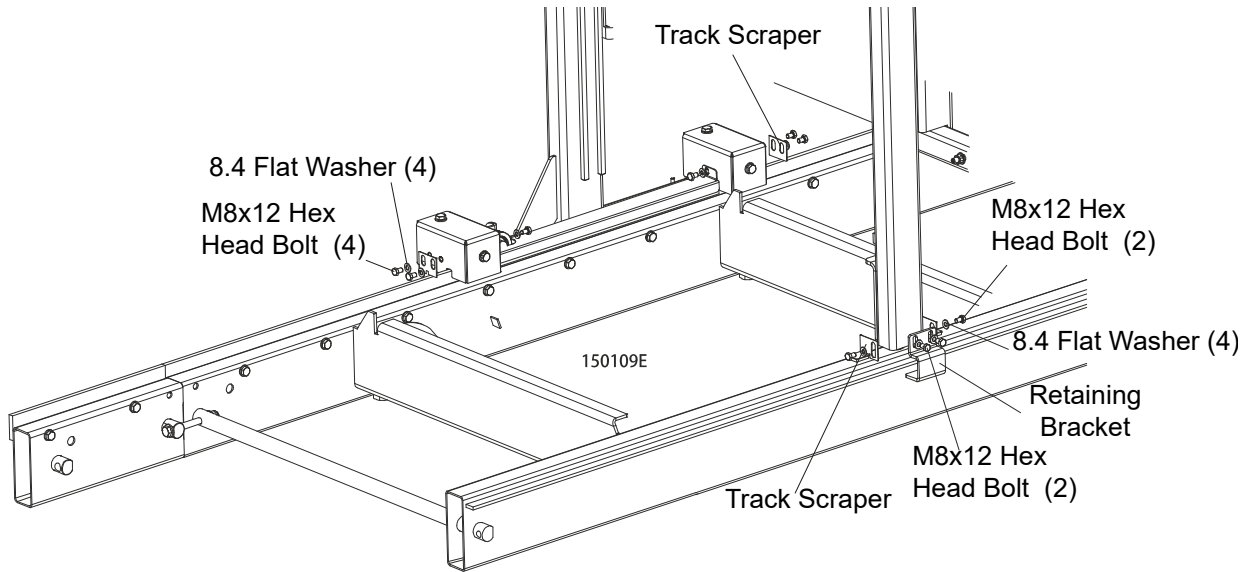


FIG. 2-9

4. Assemble the retaining bracket to the idle side upright with two hex head bolts and flat washers.
5. Assemble the two track scrapers to the idle side upright using hex head bolt and flat washer.

NOTE: Before installing the middle track cover and the remaining felt wipers, soak the felt strips with lubricating fluid (e.g. Mineral Oil).

6. Assemble mast safety pins.

See Figure 2-10.

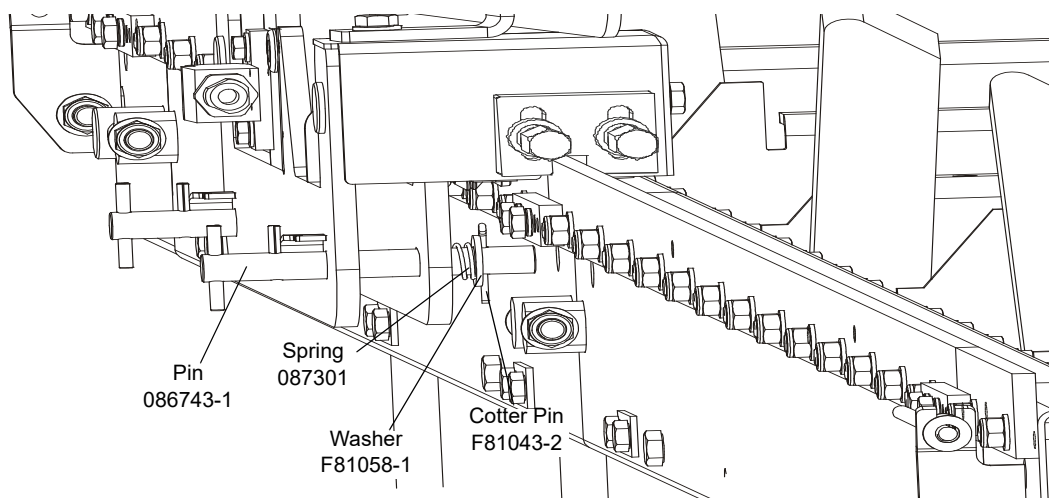


FIG. 2-10

7. Install the PC operator guard.

See Figure 2-11.

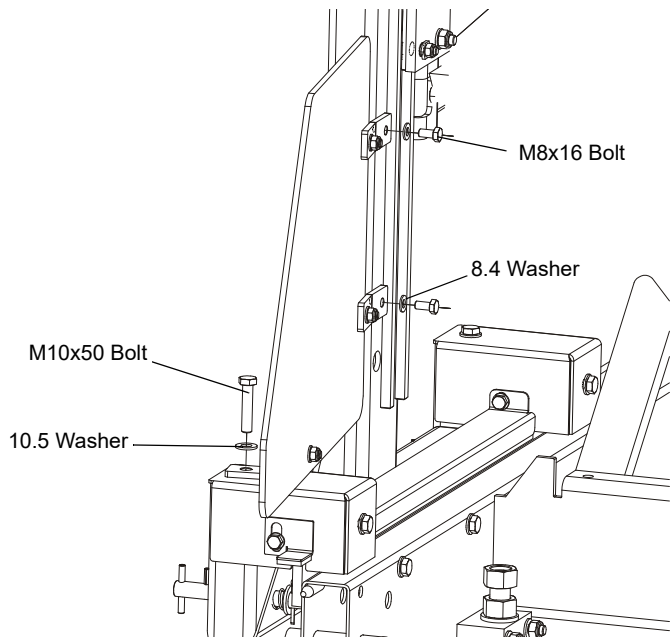


FIG. 2-11

8. Install the blade guides.

See Figure 2-12.

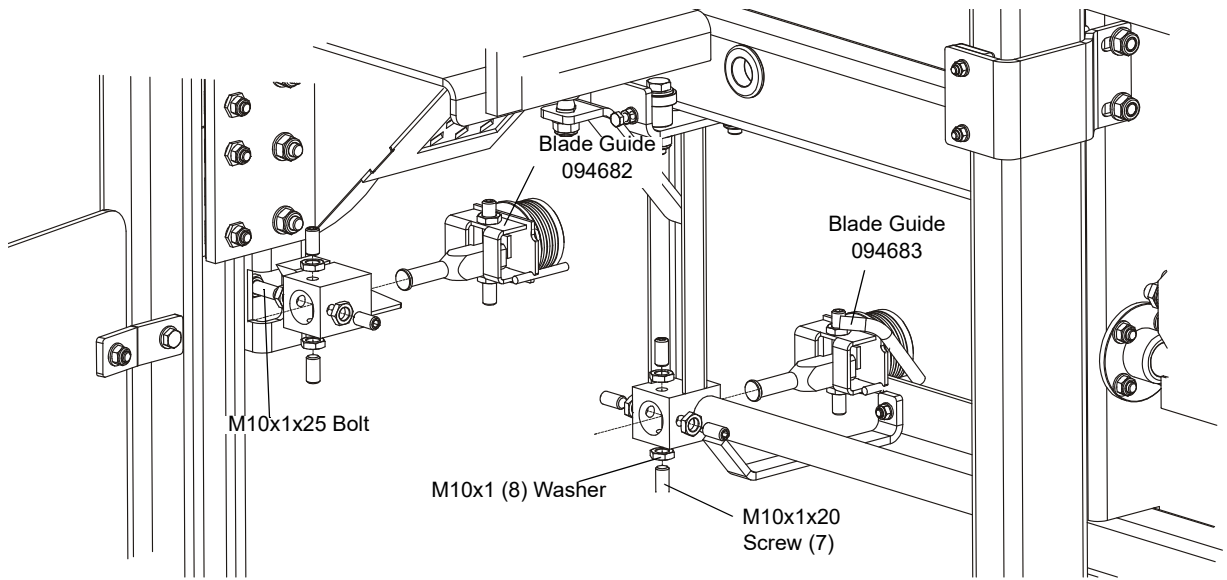


FIG. 2-12

9. Adjust the saw head stop bolt, [See Section , step 14.](#)

2.6 Feed Rope Assembly

1. Install a feed rope mounting bracket at each end of the bed assembly using a M10x30 hex head bolts and washers. Either bracket should be angled toward the end of the frame at which it is mounted as shown below.

See Figure 2-13.

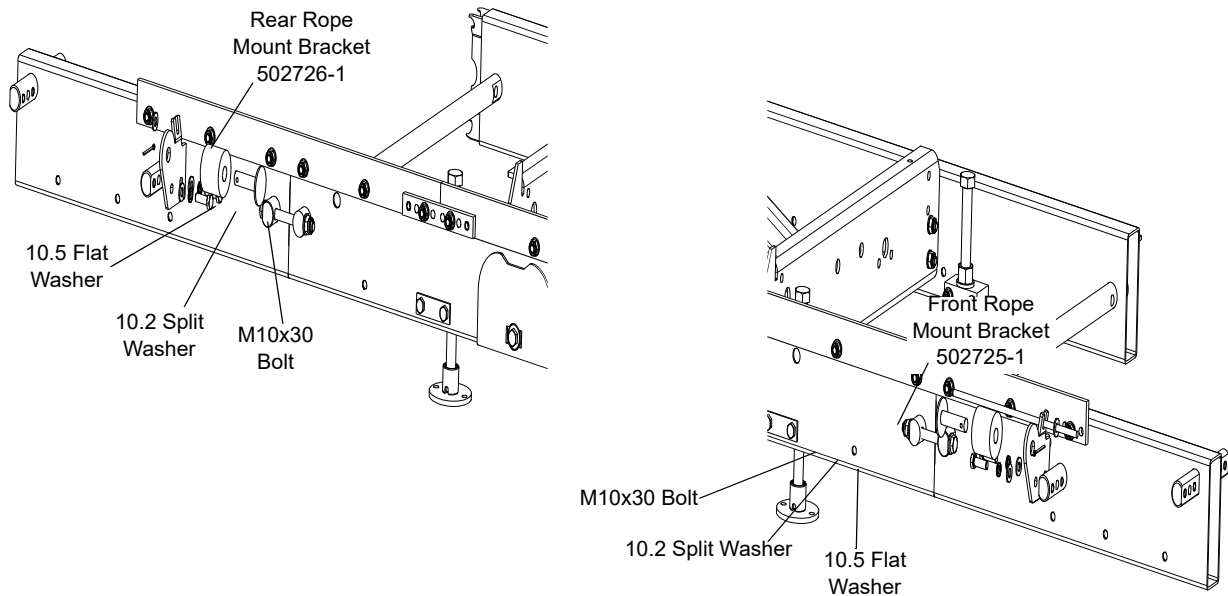


FIG. 2-13

2. Tie a knot in one end of the feed rope. Slip the knotted end of the rope into the front rope mount bracket. Route the rope between the saw head and main bed frame tube.

See Figure 2-14.

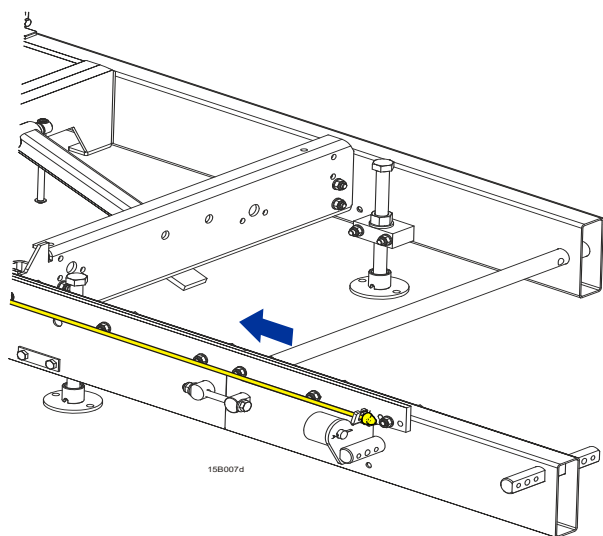


FIG. 2-14

2 SAWMILL ASSEMBLY

Feed Rope Assembly

3. Loop the rope around the inner groove of the lower v-groove roller and route to the feed crank spool.

See Figure 2-15.

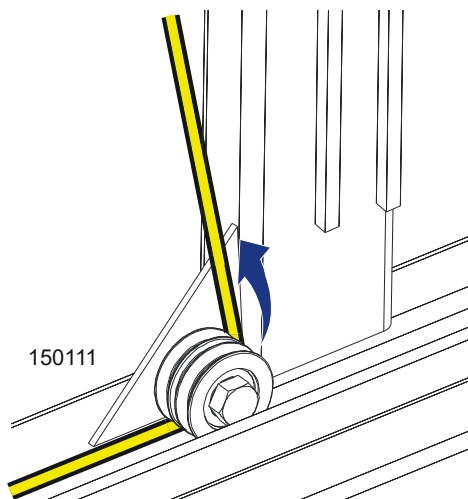


FIG. 2-15

4. Loop the rope around the feed crank spool three times and route back down to the outer v-groove roller.

See Figure 2-16.

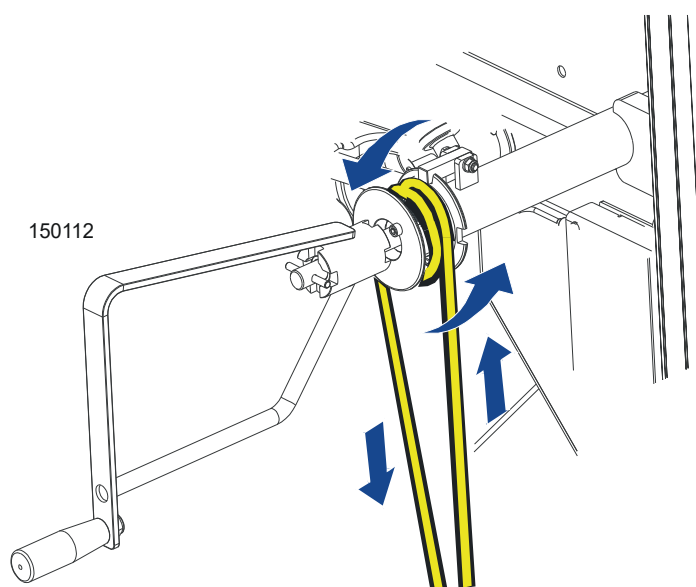


FIG. 2-16

5. Route the rope around the outer groove of the v-groove roller.

See Figure 2-17.

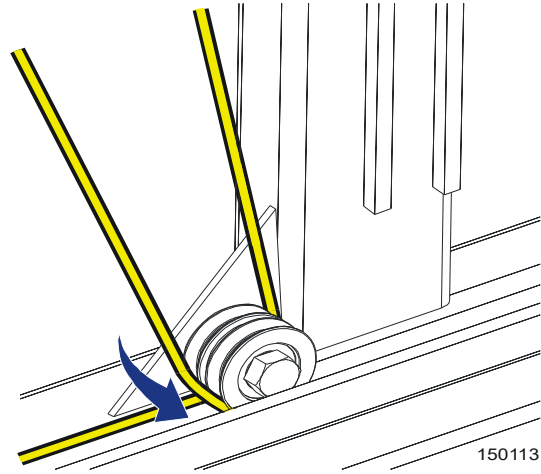


FIG. 2-17

6. Route the rope to the rear mounting bracket. Tie a knot in the end of the rope and insert into the mounting bracket. Position the knot in the rope so when installed to the rear bracket, the rope is tight.

See Figure 2-18.

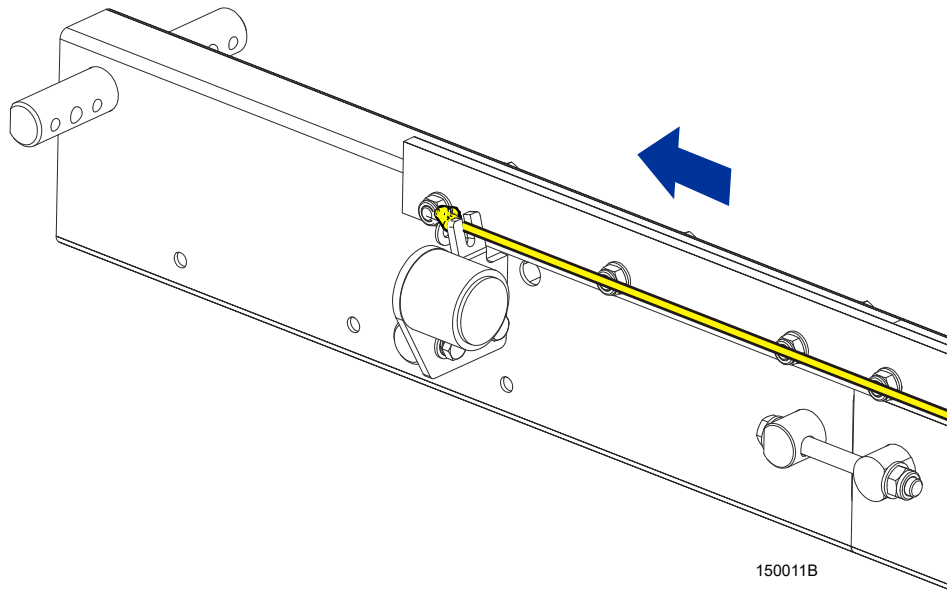
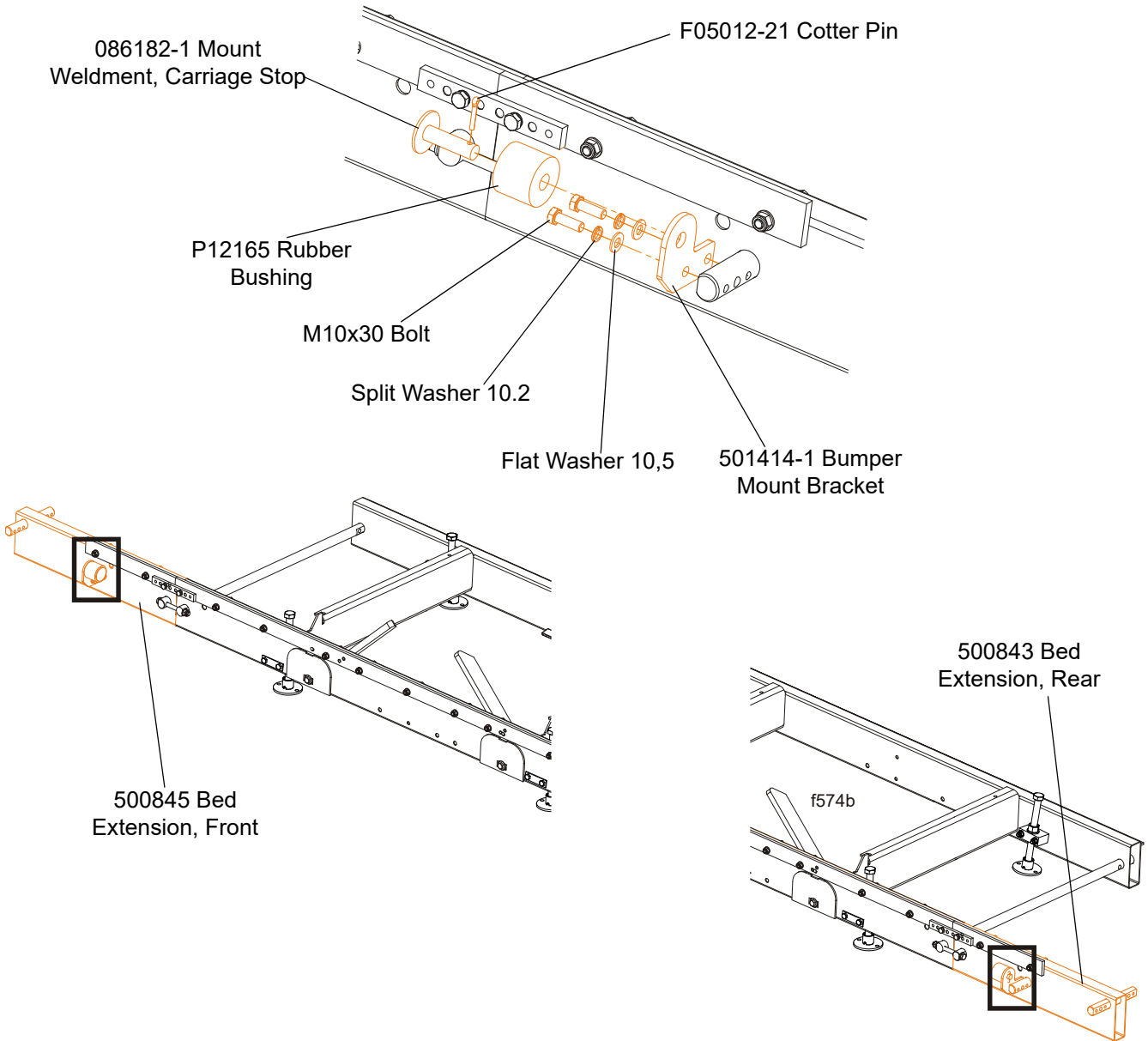


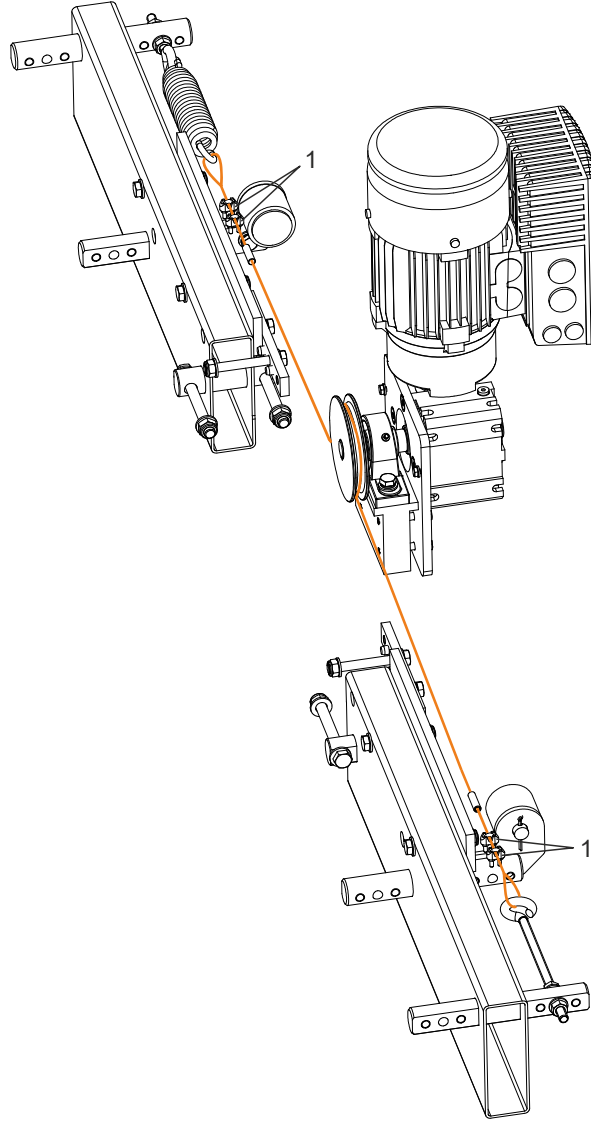
FIG. 2-18

2.7 Power Feed Rope Assembly

1. Prepare the rope for installation by placing steel caps on its ends.
2. Mount the rubber bumpers with brackets to the bed extensions - see the figure below.



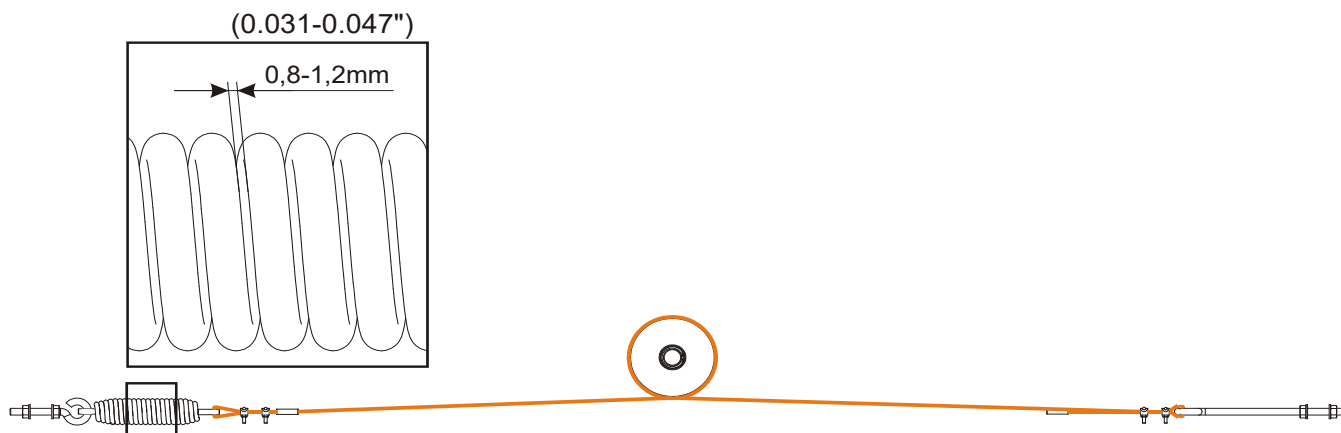
3. Install the rope, route it around the pulley, as shown below, and secure with clamps (1).



2 SAWMILL ASSEMBLY

Auxiliary Bed Rail

- Adjust the rope tension so that the gaps between the spring coils are .8-1.2mm.



2.8 Auxiliary Bed Rail

To install the auxiliary bed rail to a bed frame section, use the set of mounting holes provided between the two bed rails. Remove the existing bolt and lock nut that secures the track at this position. Use three hex head bolts and lock nuts to secure the bed rail to the bed section. Replace the track mounting bolt and lock nut.

See Figure 2-19.

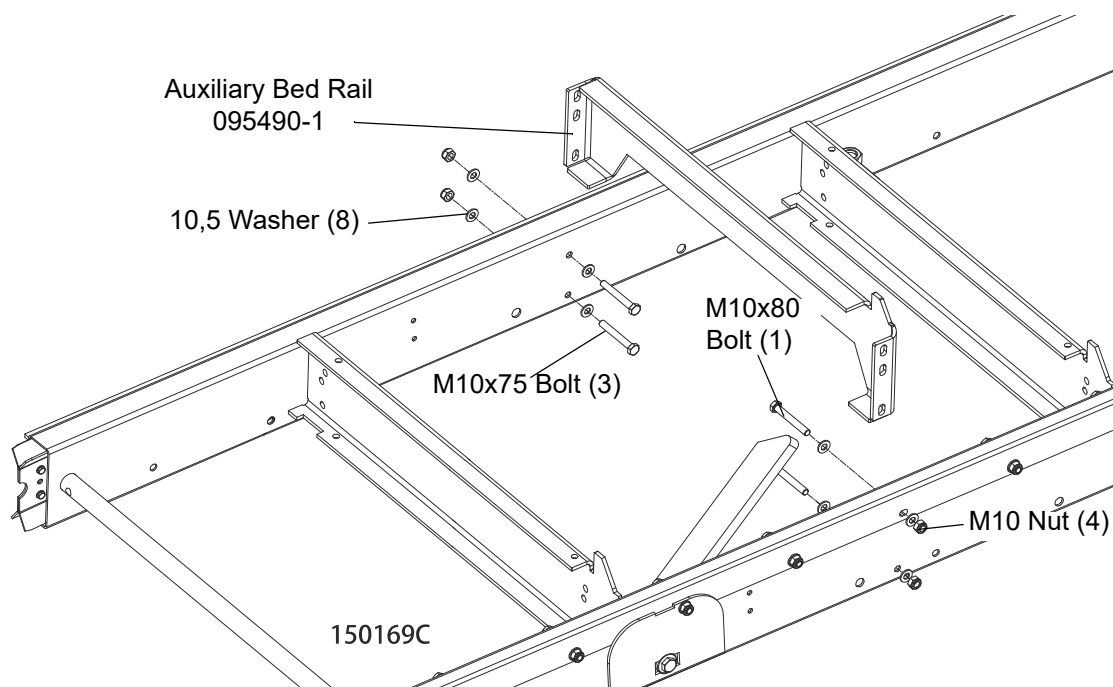


FIG. 2-19

2.9 Log Loading Ramp (Option)

To install the log loading ramp, mount the ramp bracket (1) to the bed frame section tube using two bolts (2), four washers (3) and two nuts (4) in the place shown below. Insert the ramp assembly (5) into the ramp bracket. ¹

See Figure 2-20.

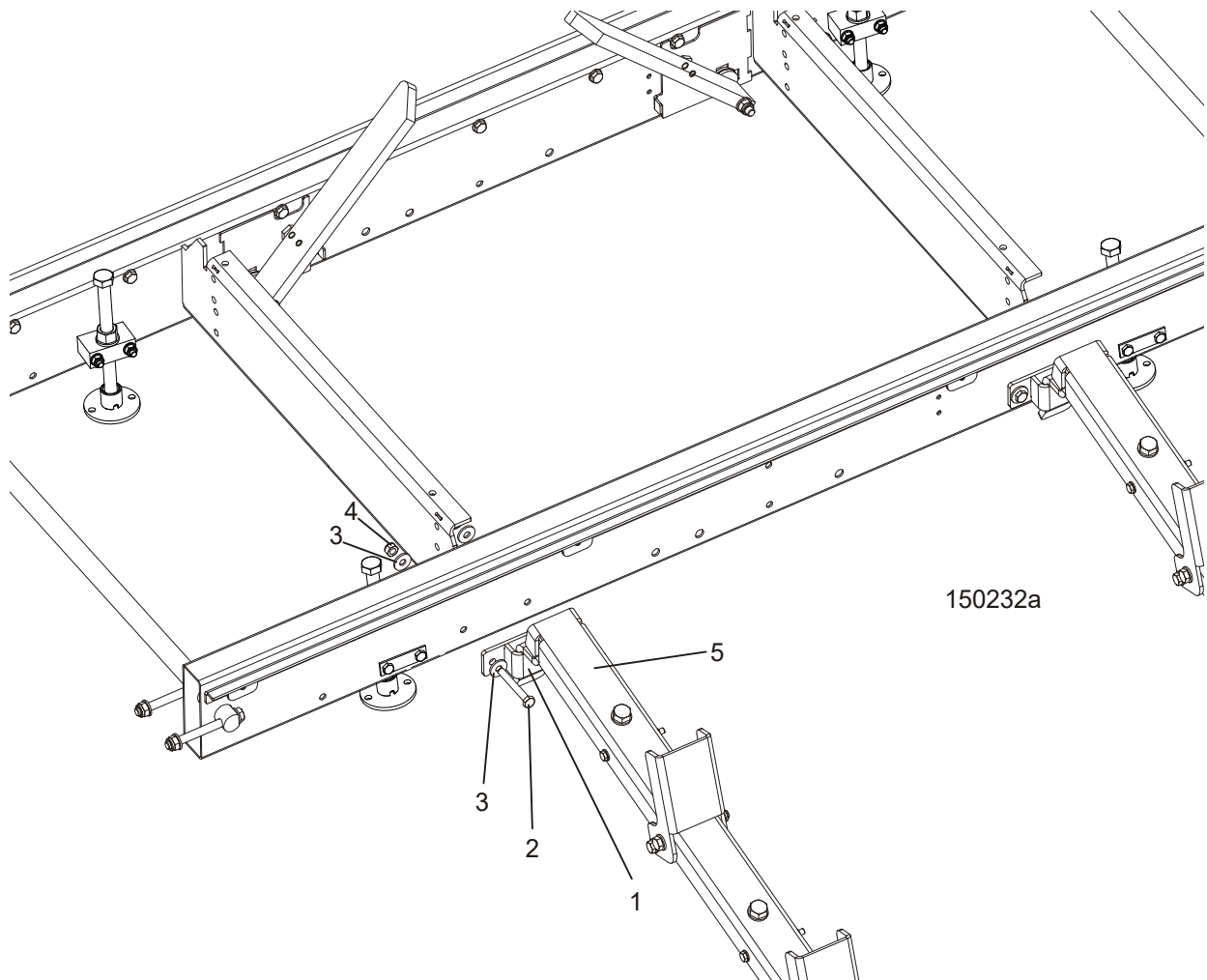
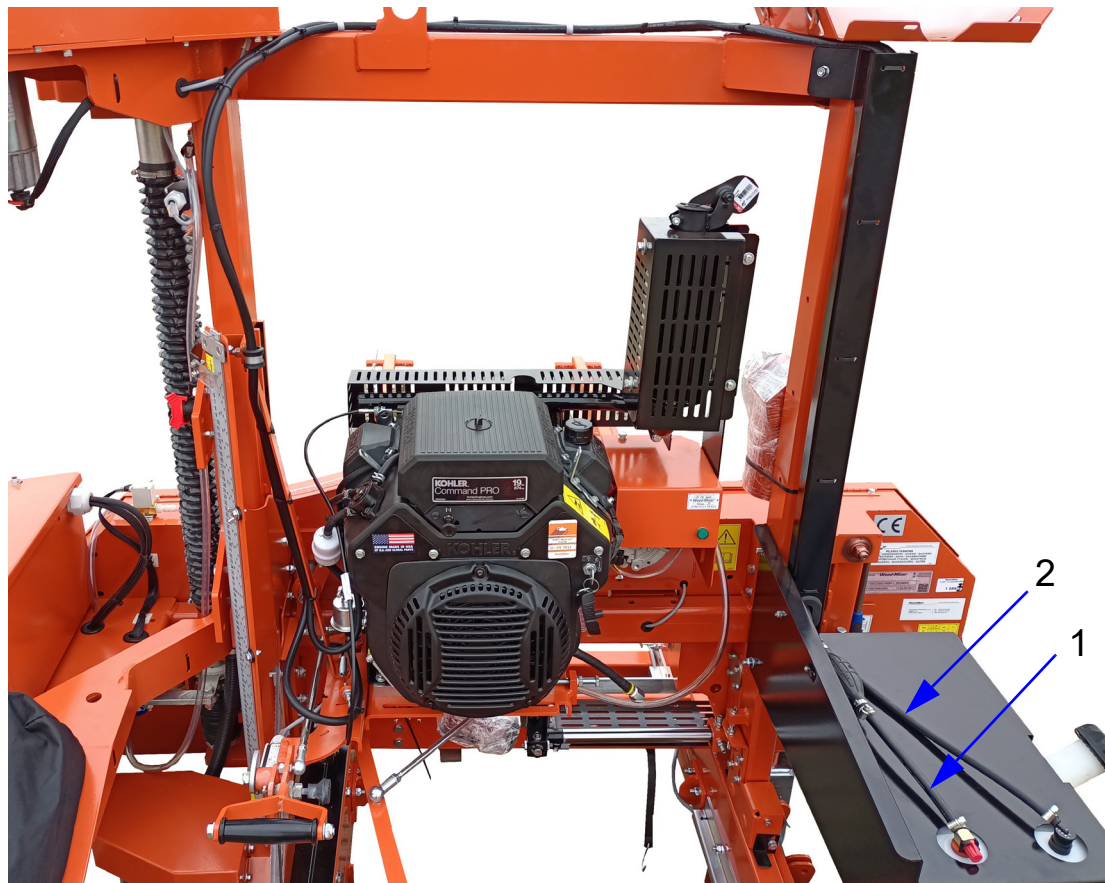


FIG. 2-20

1. See the Parts List for detailed information about part numbers and mounting hardware dimensions.

2.10 Installation of the Fuel Hoses

The fuel hoses should be placed on the sawmill mast as shown in the photos below.





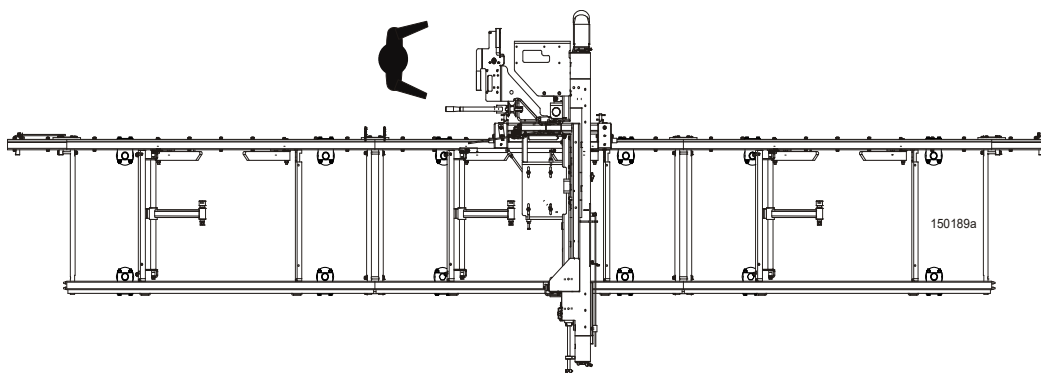
SECTION 3 SETUP & OPERATION

3.1 Sawmill Setup



IMPORTANT! Before starting to use the sawmill you have to meet the following conditions:

- Set up the sawmill on firm, level ground and level the sawmill. Secure the sawmill to the ground to prevent moving during operation. A concrete foundation or pads (rated to support 31 T/m² at each sawmill foot position) and 16mm anchored bolts are recommended.
- It is not allowed to use the sawmill with gas engine indoor. When using this sawmill type outdoor it is allowed to work without sawdust collection system connected. We recommend to setup sawmill in the way that operator position be down the wind. It will separate the operator from sawdust and engine exhaust gases
- The sawmill can be operated in temperature range from -15° C to 40° C only.
- The illumination at the operator's position should be at least 300 lx.
- The sawmill operator's position is shown below.



WARNING! In case of a blade or drive belt brake, wait until all rotating parts are completely stop. Failure to do so may result in serious injury.



DANGER! It is recommended that a 30mA Ground Fault Interrupter (GFI) be used.

The LT15 sawmills are only partially aligned in factory. Some assemblies need to be aligned by a user before first usage of the sawmill.

Assemblies aligned in factory:

- Blade drive belt tension;
- Engine rpm (DC only);
- Blade wheels (in vertical and horizontal planes);
- Blade guide arm alignment - [See Section 6.5](#);
- Blade guides - [See Section 6.6](#);
- Blade Height Scale - [See Section 6.12](#);
- Cam engaging the limit switch and/or stop bolt - [See page 3- 8](#).

The following setup procedure should be performed whenever the sawmill is moved or reassembled. If sawing problems occur and misalignment is suspected, see [SECTION 6](#) for complete alignment instructions.

1. Adjust the frame legs so the sawmill appears level. If sawmill is on soft ground, use shims under the legs if necessary.
2. Run a string from the front bed rail to the rear bed rail near the operator's side of the frame. Place identical spacers between the string and the front and rear bed rails. Measure the distance between the string and the other bed rails. Adjust the frame legs until all bed rails measure the same distance from the string.
3. Loosen the auxiliary bed rail bolts and adjust the rail so it is the same distance from the string as the main bed rails. Retighten the bolts.

See Figure 3-1.

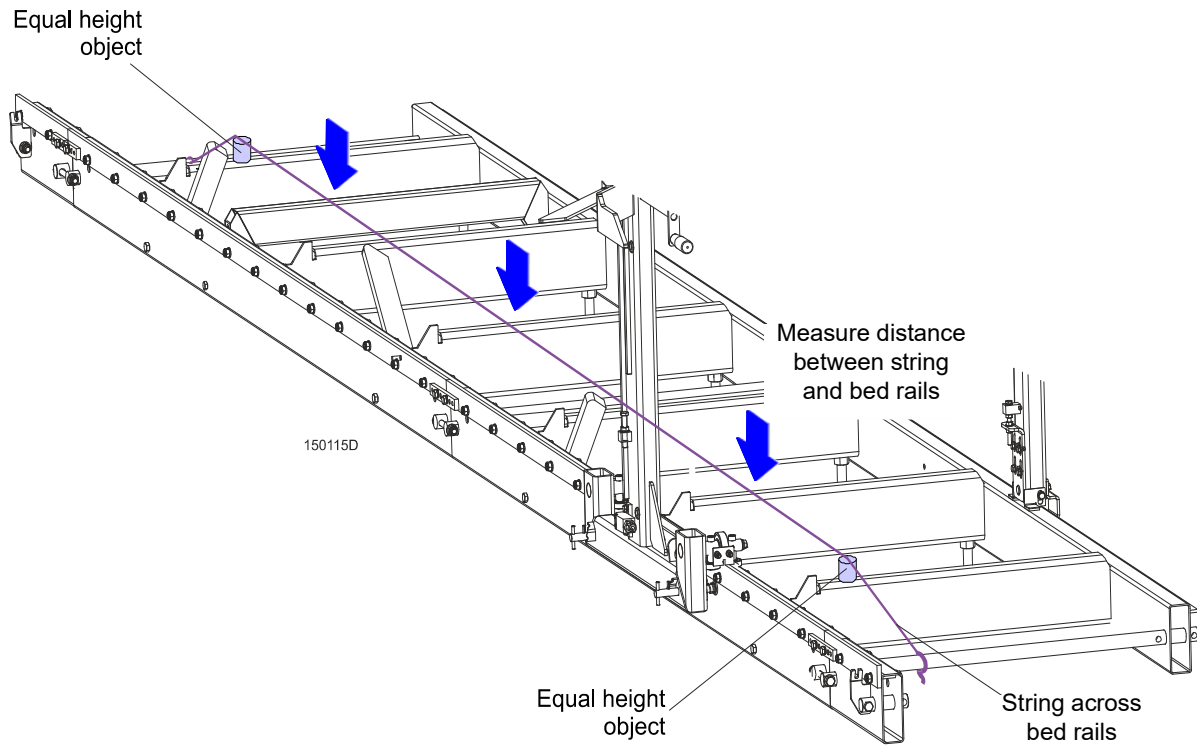


FIG. 3-1

4. Repeat the bed rail adjustment with the string at the other side of the sawmill frame.
5. Install a blade ([See Section 3.2](#) through [Section 3.4](#)) and move the saw carriage until the blade is positioned over the front bed rail.
6. The blade guide rollers should not touch and deflect the blade and the blade guide arm should be adjusted all the way out, away from the other blade guide.
7. Measure the distance from the bed rail to the bottom of the blade near the inside blade guide.
8. Measure the distance from the bed rail to the bottom of the blade near the outside blade guide.

See Figure 3-2. When the blade is parallel to the bed, it will measure the same distance from the bed rail at the inside and outside of the saw head. To adjust the saw head tilt, loosen the four mounting bolts of the idle side roller bracket, the two scraper mounting bolts and the two mounting bolts of the mast retaining bracket. Use the saw head adjustment nuts to move the outside of the

saw head up or down.

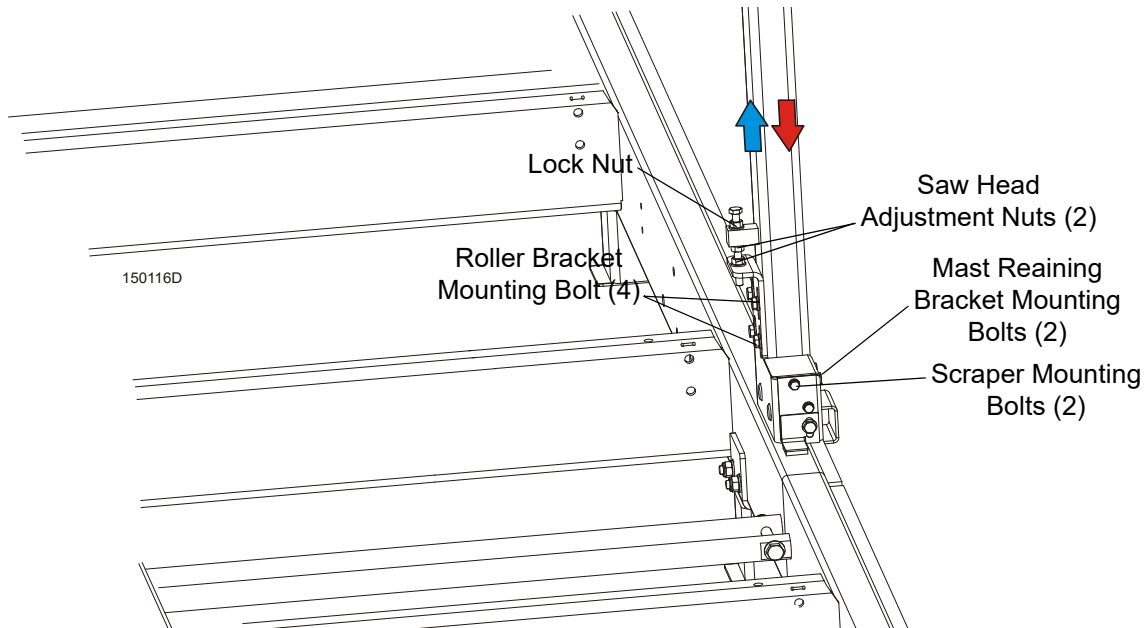


FIG. 3-2

See Figure 3-3. Make sure the entire face of each slide pad makes contact with the mast. Use the adjustment nuts shown below to adjust the slide pads if necessary.

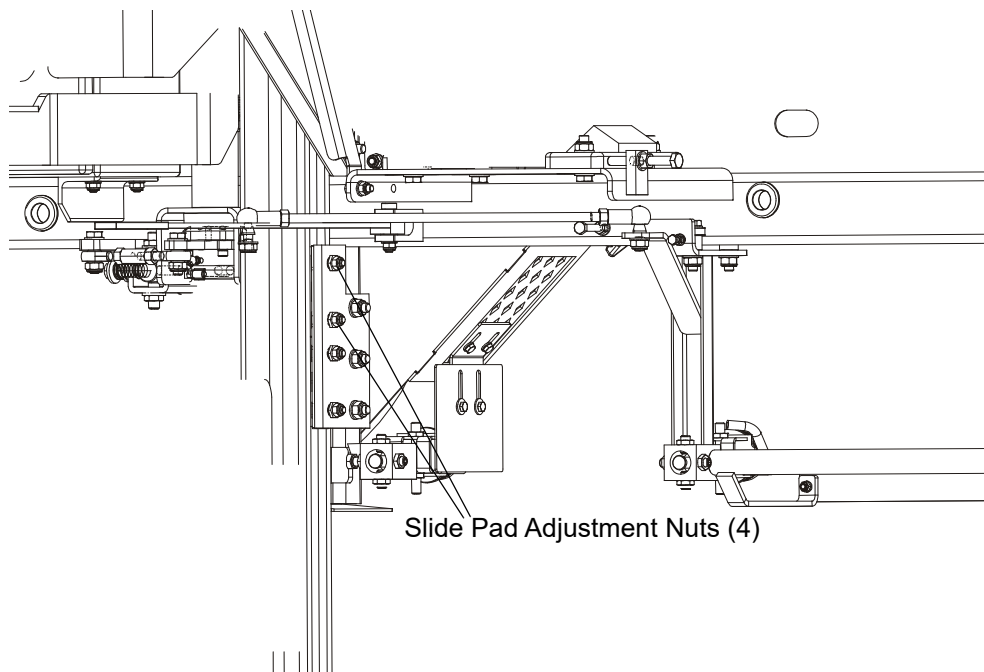


FIG. 3-3

9. Check the vertical alignment of each blade wheel using the blade guide alignment tool.
 - Attach the tool to the blade near the outer blade guide. Be sure the tool does not rest on a tooth or burr, and is lying flat on the blade.

See Figure 3-4.

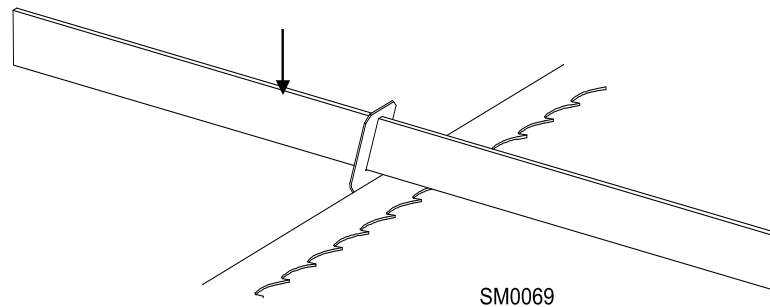


FIG. 3-4

- Move the saw head so the front end of the tool is positioned over the first bed rail. Measure from the bottom of the tool to the top surface of the bed rail.
- Move the saw head so the rear of the tool is positioned over the bed rail. Again, measure from the bottom of the tool to the bed rail.
- If the two measurements differ by more than 1/16" (1.5 mm), adjust the vertical tilt of the idle-side blade wheel. [See Figure 3-5.](#)
- Remove the tool from the blade and reattach it near the inner blade guide. Measure from the tool to the bed rail at both ends of the tool. If the measurements at the front and rear ends of the tool differ by more than 1/16" (1.5 mm), adjust the vertical tilt of the drive-side blade wheel. [See Figure 3-6.](#)

See Figure 3-5. To tilt the idle-side blade wheel up, loosen the bottom adjustment screw 1/2 turn. Loosen the nut on the top adjustment screw and tighten the screw. Tighten the top and bottom nuts.

To tilt the wheel down, loosen the top adjustment screw 1/2 turn. Loosen the nut on the bottom adjustment screw and tighten the screw. Tighten the top and bottom nuts.

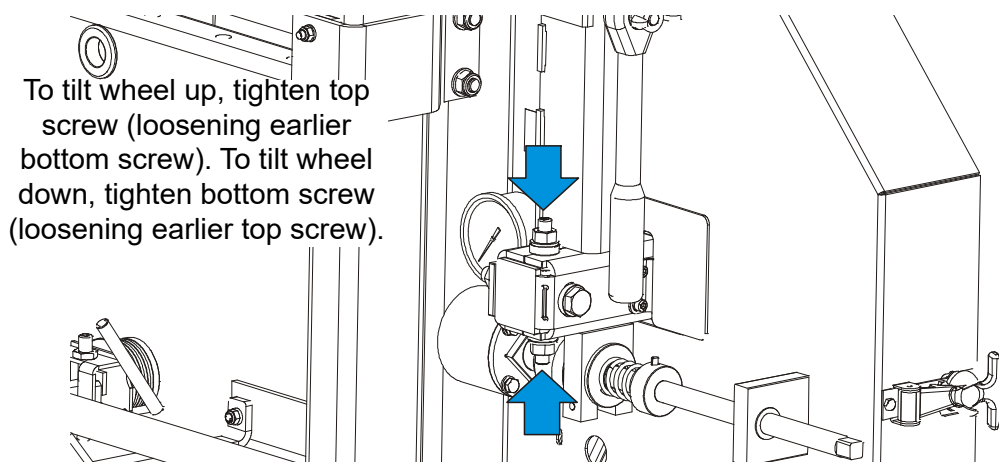
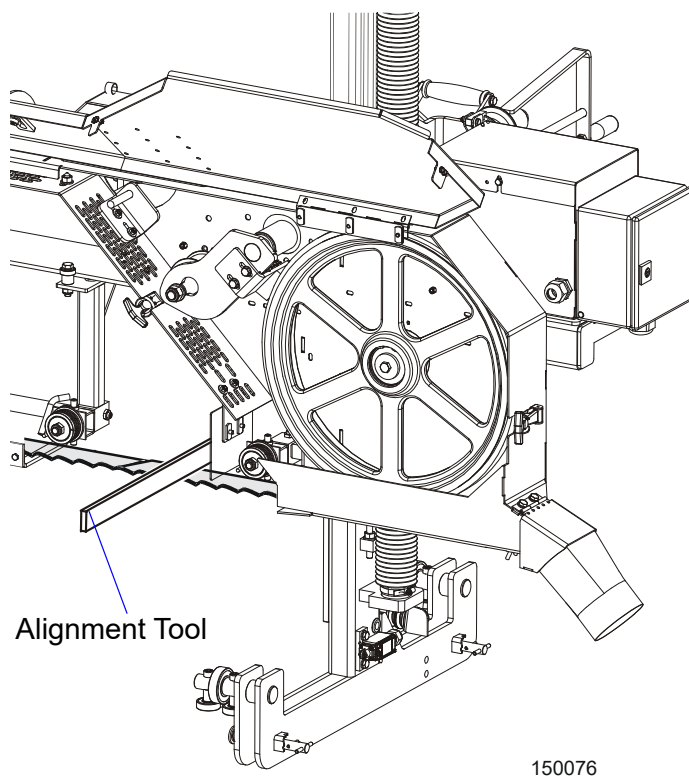


FIG. 3-5

See Figure 3-6. To tilt the drive-side blade wheel down, loosen the top adjustment screw, loosen the nut on the bottom adjustment screw and tighten the bottom screw. Tighten the top and bottom nuts.

To tilt the wheel up, loosen the bottom adjustment screw, loosen the nut on the top adjustment screw and tighten the top screw. Tighten the top and bottom nuts.



To tilt wheel up, tighten top screw (loosening earlier bottom screw). To tilt wheel down, tighten bottom screw (loosening earlier top screw)

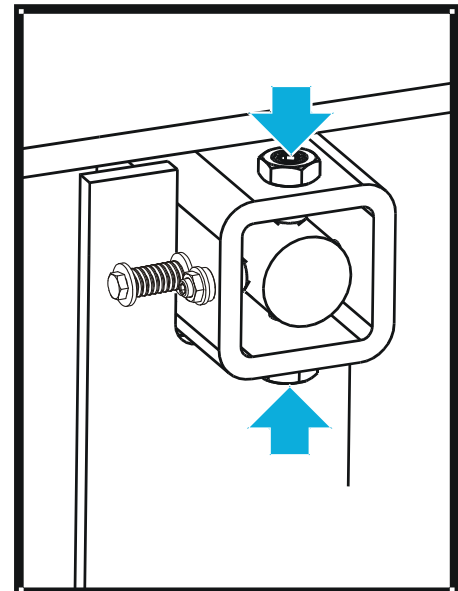


FIG. 3-6

- Recheck the vertical alignment of each blade wheel. Readjust if necessary.
10. Adjust the spacing between each blade guide roller flange and the back of the blade. [See Section 6.9.](#)
 11. Adjust the horizontal angle of the blade guides. [See Section 6.10.](#)
 12. Adjust the blade deflection ([See Section 6.7](#)) and the vertical angle of the blade guides ([See Section 6.8](#)).

HINT: It is best to preliminarily set the blade deflection so that it is 3 - 4 mm, then adjust the blade guides in the vertical plane and make the final adjustments to the blade deflection. The proper blade deflection is 6 mm. After adjusting the blade deflection, recheck the vertical alignment of the blade guides and adjust if necessary.

13. Install the blade height scale. To do that, first measure the distance from the bottom edge on a down-set tooth of the blade to the top of the bed rail. Then stick the blade height scale on the mounting bracket so that it indicates the true distance from the blade to the bed. Adjust the scale if necessary. [See Section 6.12.](#)
14. Bolt the blade guide guard so that its bottom edge is about 5 mm above the blade.

See Figure 3-7.

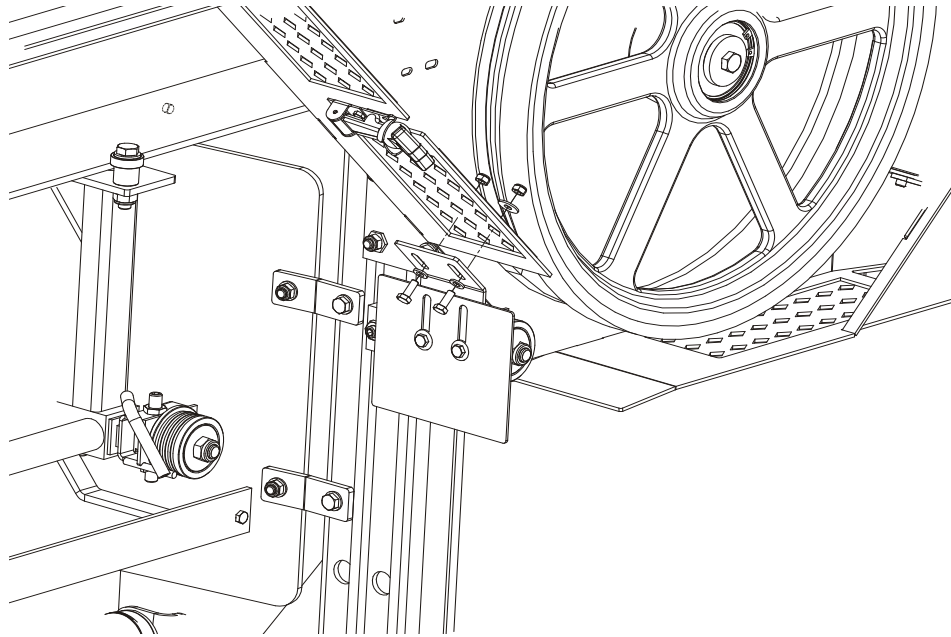


FIG. 3-7

15. Adjust the cam engaging the limit switch as well as the saw head stop bolt so that the saw head stops moving at its lower travel limit, i.e. at the height of 25 mm above the bed.

See Figure 3-8.

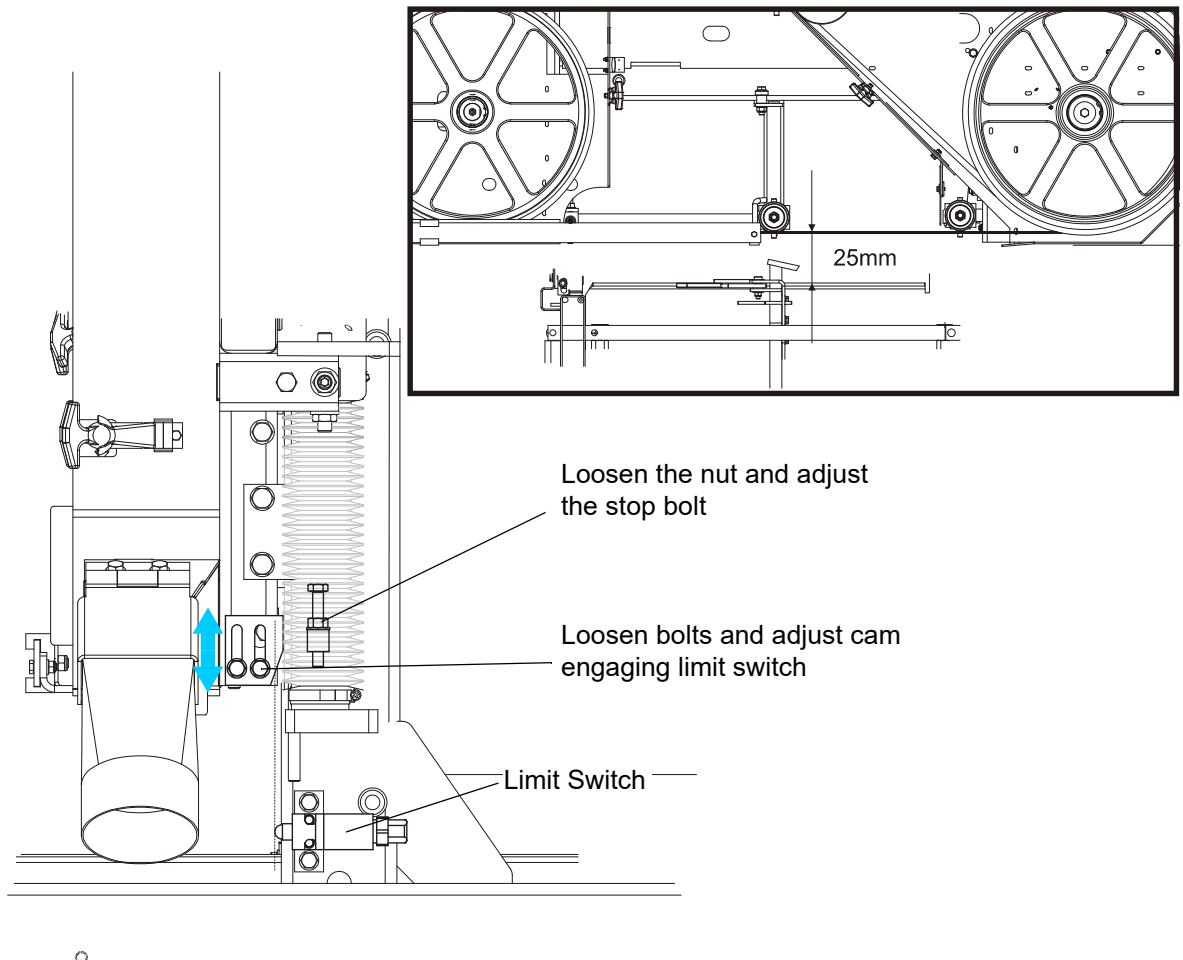


FIG. 3-8

3.2 Replacing The Blade

DANGER! Always disengage the blade and shut off the sawmill engine before changing the blade. Failure to do so will result in serious injury.

WARNING! Always wear gloves and eye protection when handling bandsaw blades. Changing blades is safest when done by one person! Keep all other persons away from area when coiling, carrying or changing a blade. Failure to do so may result in serious injury.

Adjust the blade guide arm all the way open.

Open the two blade housing covers that cover the blade wheels. Turn the blade tension handle to

release the blade tension until the wheel is pulled in and the blade is lying loose in the blade housing. Lift the blade out of the blade housing.

When installing a blade, make sure the teeth are pointing the correct direction. The teeth should be pointing toward the operator side of the mill when you are looking at the blade below the blade guides. Install the blade so it is lying around the wheels.

Position 1 1/4" wide blades on the wheels so the gullet is 1/8" (3.0 mm) out from the edge of the wheel. Position 1 1/2" wide blades on the wheels so the gullet is 3/16" (4.5 mm) out from the edge of the wheel.

Close the blade housing covers.

Next, turn the tension handle until the blade is tensioned correctly.

3.3 Tensioning The Blade

See Figure 3-9. Turn the blade tension handle clockwise until the tension gauge indicates the recommended tension. Check the blade tension occasionally when adjusting the cant control or while cutting. As the blade and belts heat up and stretch, the blade tension will change.

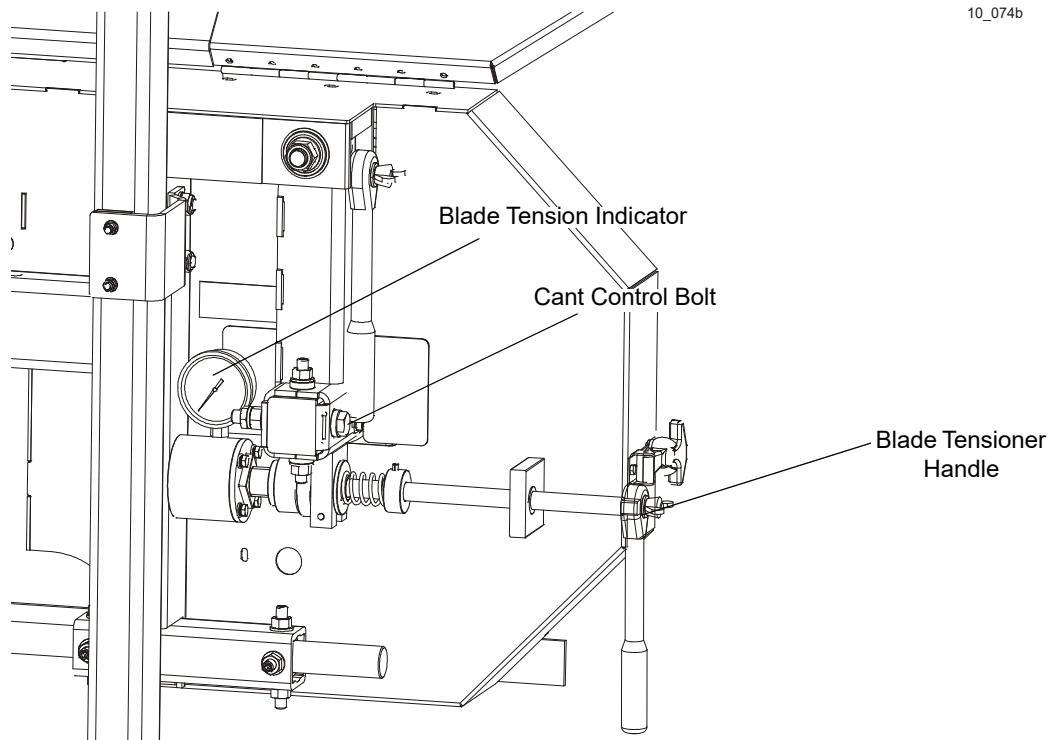



FIG. 3-9

 **CAUTION!** Release the blade tension when the resaw is not in use (for example at the end of a shift). Tension the blade again before starting the motor.


See Table 3-1. The recommended tension for different blades is shown below.

Blade Type	Blade Dimensions		Tension range	
	Width (mm)	Height (mm)	PSI	Bar
275	1.07	32	1015-1088	70-75
375	1.14	32	1088-1160	75-80
2735	1.07	35	1160-1233	80-85

TABLE 3-1

3.4 Tracking The Blade

1. Make sure the blade housing covers are closed and all persons are clear of the blade.
2. Start the engine (or motor).
3. Pull lightly on the clutch handle, rotating the blade until the blade positions itself on the wheels.

 **WARNING!** Do not spin the blade wheels by hand. Spinning the blade wheels by hand may result in serious injury.

4. Release the clutch handle to stop the blade. Turn off the engine and check the position of the blade on the blade wheels.

See Figure 3-10. Position 1 1/4" wide blades so the gullet is 1/8" (3.0 mm) out from the edge of the blade wheel ($\pm 1/32$ [.75 mm]).

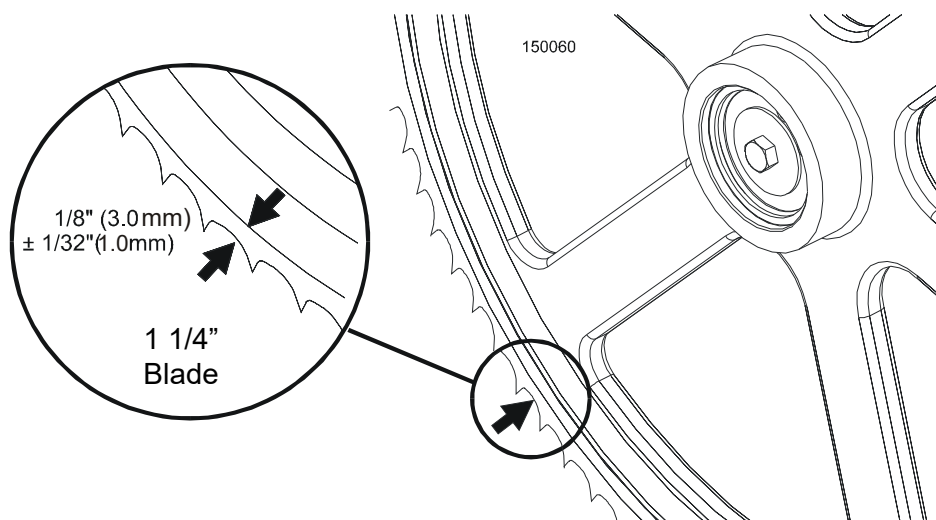


FIG. 3-10

See **Figure 3-11**. To adjust where the blade travels on the blade wheels, use the cant control handle.

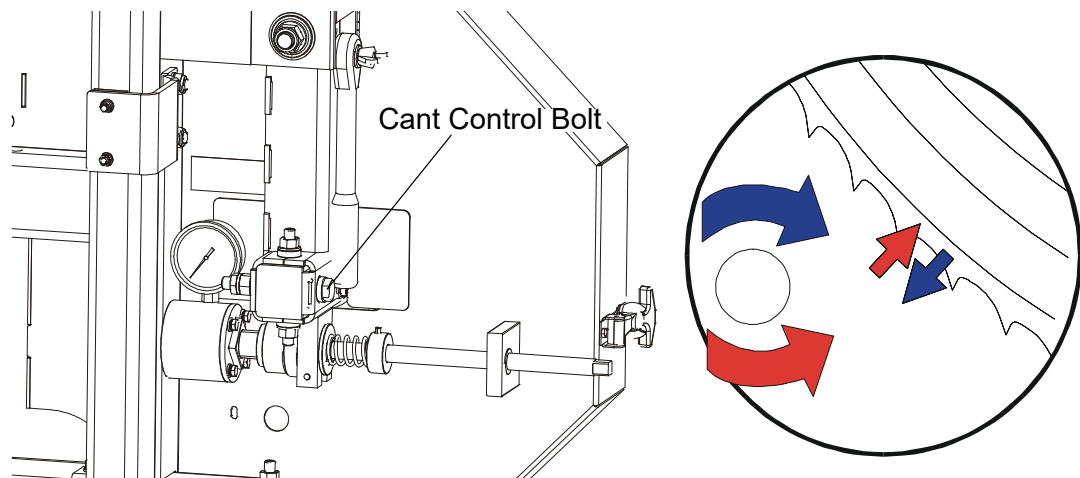


FIG. 3-11

See **Figure 3-12**. If the blade is too far out, back the blade onto the wheel by turning the cant control counterclockwise. If the blade is too far in, turn the cant control clockwise until the gullet of the blade is the correct distance from the front edge of the wheel.

5. Adjust the blade tension if necessary to compensate for any changes that may have occurred while adjusting the cant control.
6. Close the blade housing covers.

! DANGER! Make sure all guards and covers are in place and secured before operating the sawmill. Failure to do so may result in serious injury. Be sure the blade housing and pulley covers are in place and secure.


IMPORTANT! After aligning the blade on the wheels, always double-check the blade guide spacing and location. (See [SECTION 6](#) for more information.)


3.5 Starting The Engine

See the appropriate manual supplied with your specific engine configuration for starting and operating instructions.

! DANGER! Make sure all guards and covers are in place and secured before operating the sawmill. Failure to do so may result in serious injury. Be sure the blade housing and pulley covers are in place and secure.

DANGER! Always be sure the blade is disengaged and all persons are out of the path of the blade before starting the engine or motor. Failure to do so will result in serious injury.

 **WARNING!** Always wear eye, ear, respiration, and foot protection when operating the sawmill. Failure to do so may result in serious injury.

 **CAUTION!** If at any time you need to immediately stop the blade engine, release the safety button located on the control box.

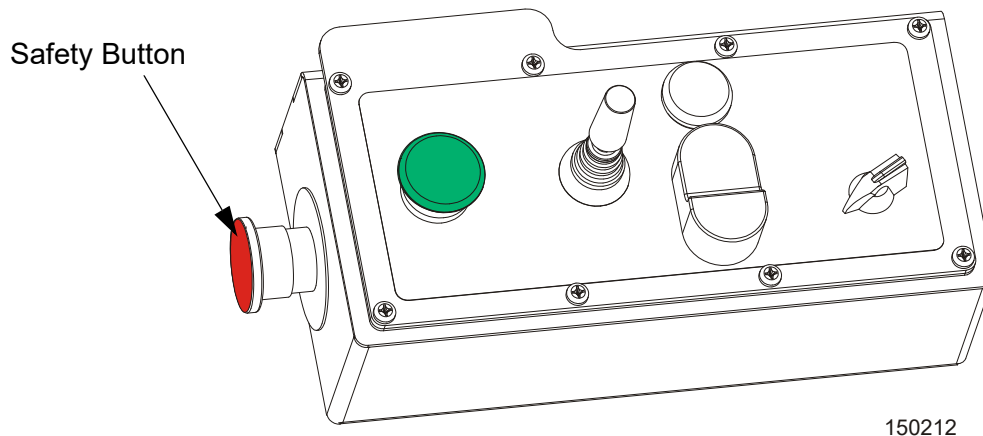



FIG. 3-12


3.6 Loading, Turning, And Clamping Logs

To Load Logs

1. Move the saw carriage to the front end of the frame.

 **CAUTION!** Before loading a log, be sure the cutting head is moved far enough forward so the log does not hit it. Failure to do so may result in machine damage.

2. Adjust the log clamps all the way down and move them toward the loading side of the sawmill frame.

 **CAUTION!** Be sure the log clamps are all the way down before loading a log onto the bed. Failure to do so may result in machine damage.

3. Raise the side supports on the sawmill bed to prevent the log from falling off the side of the bed.
4. Position the log at the foot of the ramps.
5. Use a cant hook to roll the log up the ramps and onto the sawmill bed. Position the log against the side supports.
6. Remove the log ramps and set aside.



CAUTION! The saw head will hit the spring-loaded ramp stops when adjusted for low cuts. Remove the loading ramps before sawing to prevent damage to the saw head and/or blade guide arm.

If you did not purchase the optional loading ramps, use boards for ramps or use log loading equipment to load the log on the sawmill bed.

To Turn Logs

1. Use a cant hook to spin the log against the side supports until it is turned the way you want it for the first cut.

To Clamp Logs

1. Position the clamps against the log, far enough down so they are below your first few cuts. Turn the clamps screws in so they move the log firmly against the side supports.

See Figure 3-13.

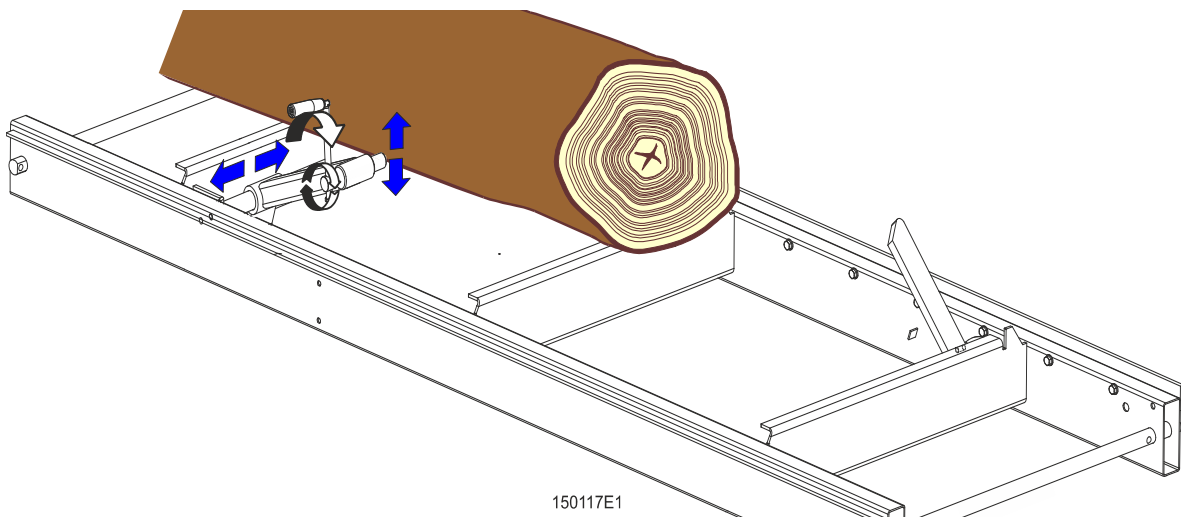


FIG. 3-13

2. Be sure to leave crank in the bottom position to avoid damage to the blade.

See Figure 3-14.

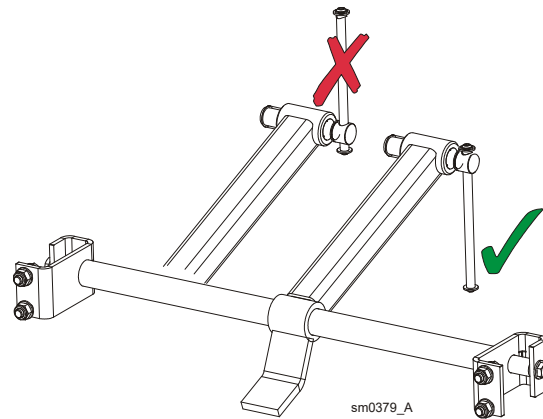


FIG. 3-14

3. Make sure the side supports are positioned low enough for the blade to pass over them. If they are not, back the clamps off slightly and push the side supports down until they are positioned below the level of your first few cuts.

To Level A Tapered Log

See Figure 3-15. Use shims or the optional wedge to raise either end of a tapered log, if desired.

Shim one end of the log until the heart of the log measures the same distance from the bed rails at each end of the log.

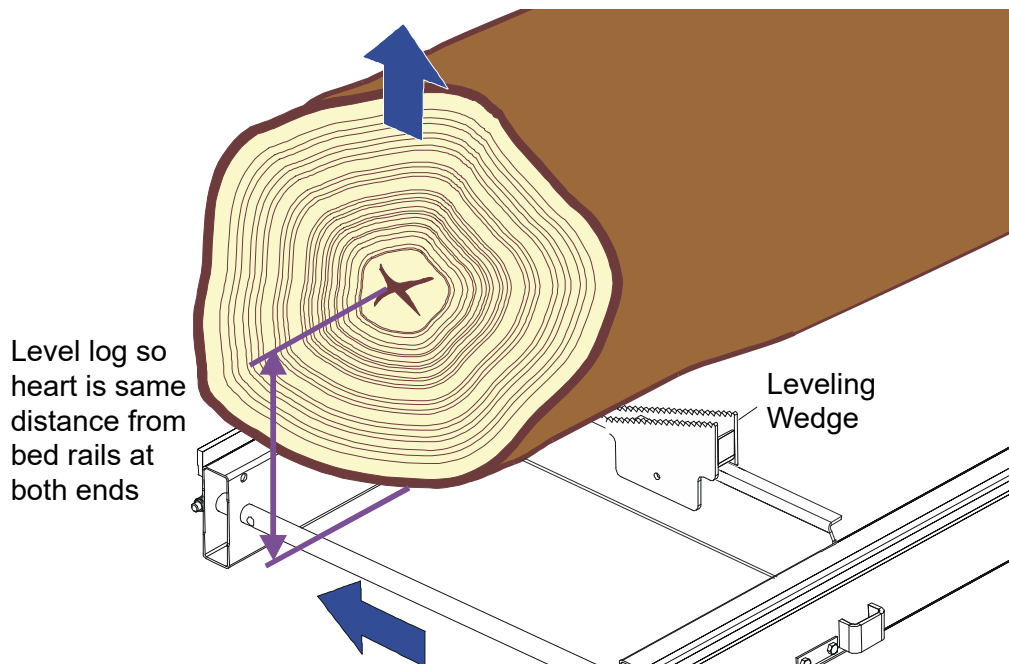


FIG. 3-15

3.7 Up/Down Operation

1. Install a blade, if needed, and check for correct blade tension. ([See Section 3.3.](#))

Set the cutting head to the desired height. (The blade height scale shows the height of the blade above the bed rails.)

See Figure 3-16. Use the up and down buttons shown below to raise or lower the cutting head.

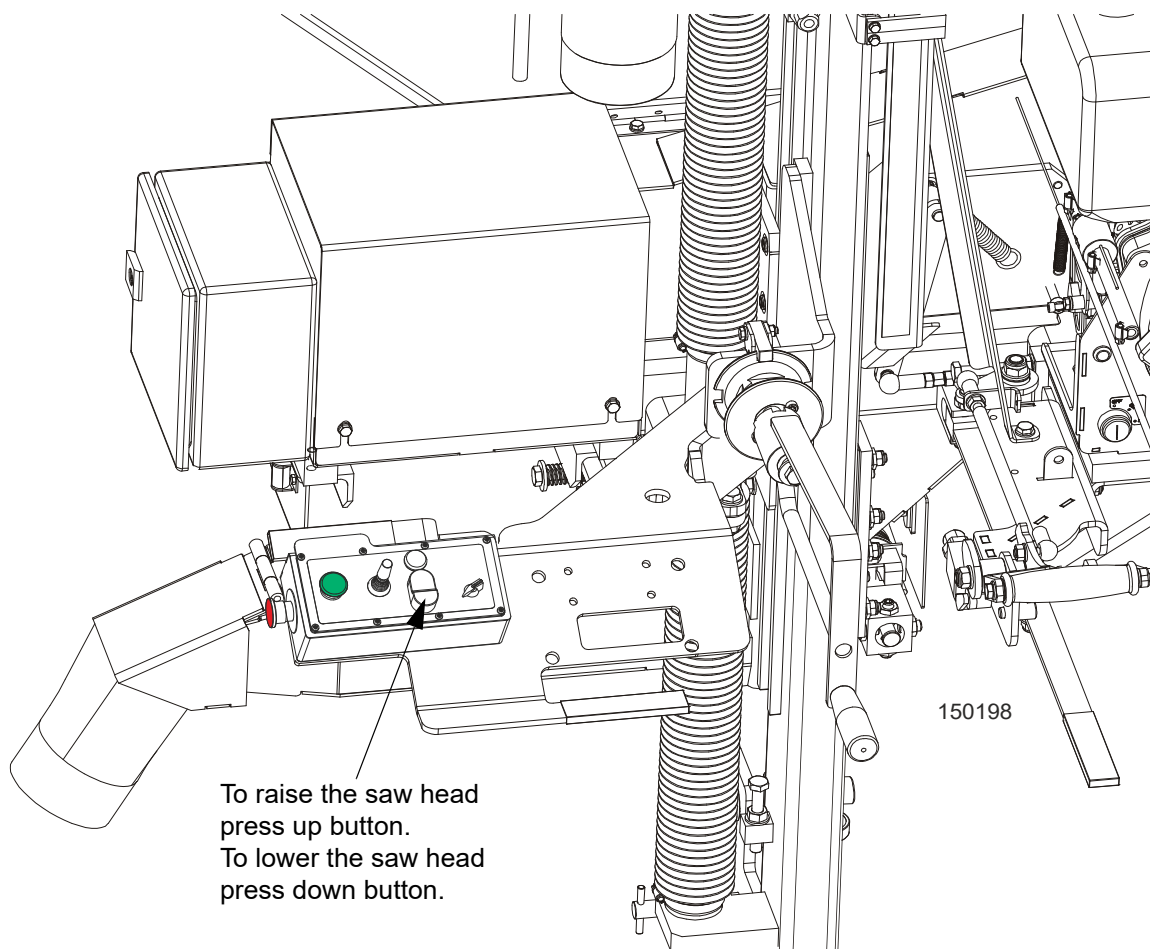


FIG. 3-16

CAUTION! DO NOT try to force the carriage above the 27" (68 cm) mark or below the 1" (2.54 cm) mark. Damage to the up/down system may result.

3.8 Blade Guide Arm Operation

1. Look down the length of the log to see its maximum width. The outer blade guide roller should be adjusted to clear the widest section of the log by less than 1" (25.4 mm).
2. Use the blade guide arm handle to adjust the outer blade guide as necessary. Move the blade guide arm handle right to move the arm out. Move the handle left to move the arm in.

See Figure 3-17.

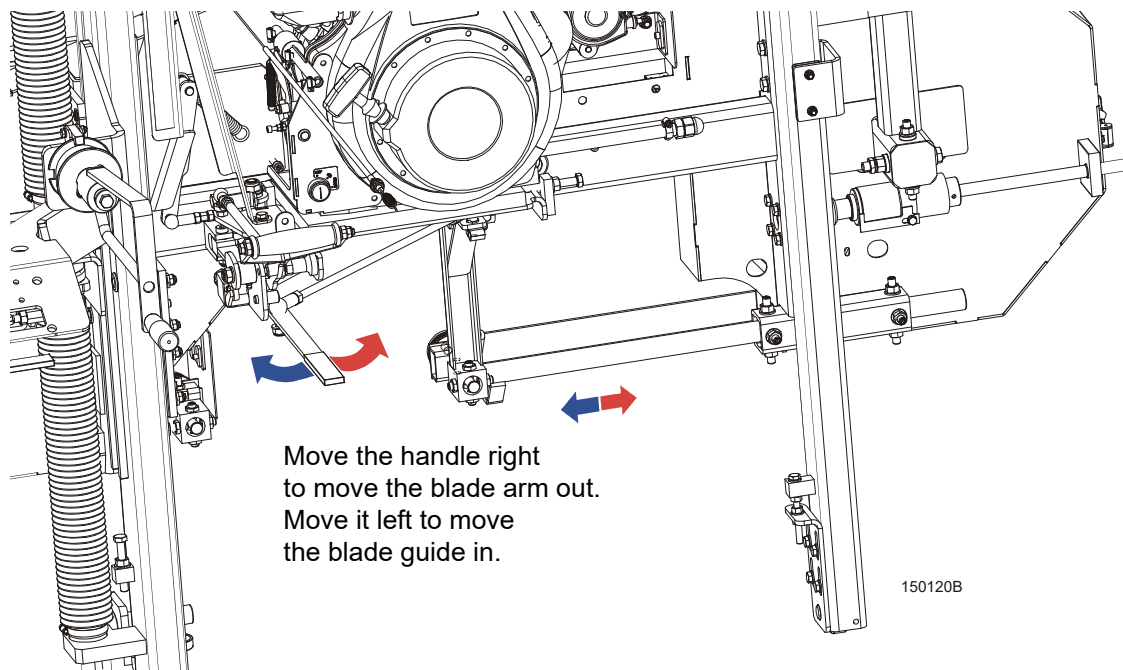


FIG. 3-17

3.9 Blade Drive Operation

⚠ DANGER! Make sure all guards and covers are in place and secured before operating the sawmill. Failure to do so may result in serious injury. Be sure the blade housing and pulley covers are in place and secure.

Be sure the blade housing and pulley covers are in place and secure before starting the engine or motor. Use the rubber latches to fasten blade housing covers shut. If the blade housing covers are not closed and secured the safety shut-off switches interrupt the ignition (the contactor) circuit and the engine motor can not be started. If the cover is opened during the mill operation the engine/motor will be stopped.

Gas engine only

1. Clear any loose objects from the area of the blade, motor, and drive belt.
2. Make sure the clamps and side supports are adjusted below the level of your first few cuts.

3 Setup & Operation

Feed Operation

3. Start the engine as instructed in the engine manual.

See **Figure 3-18**. The tensioner handle is located next to the engine.

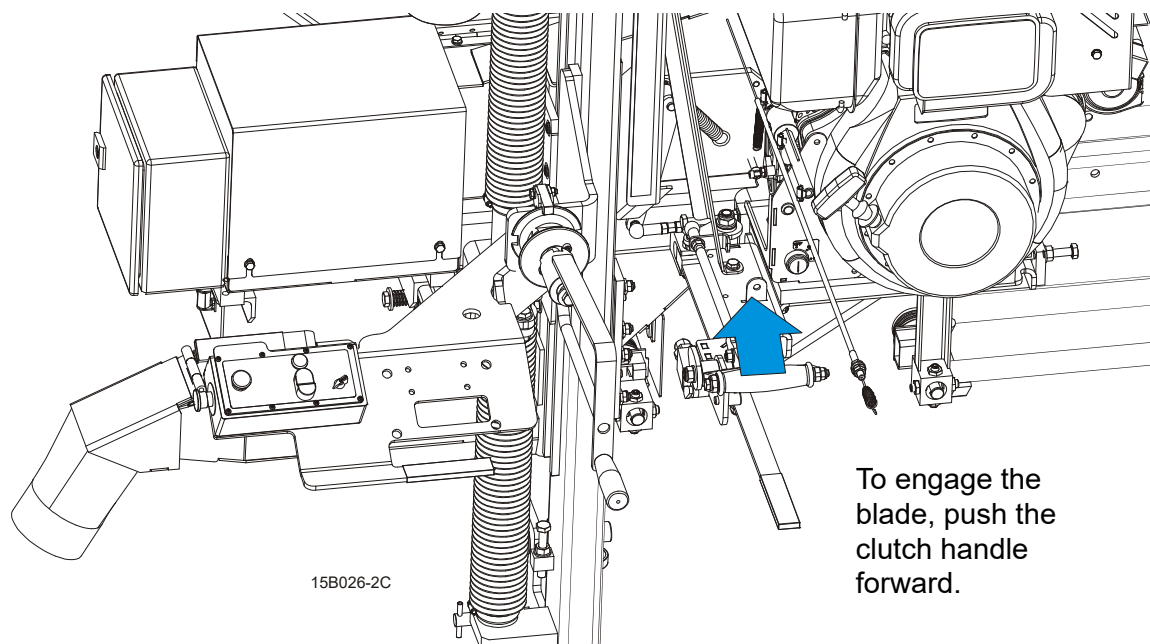


FIG. 3-18

4. To engage the blade, press the safety switch with your left hand and hold it down. Then push the tensioner handle forward until it locks. This engages the drive mechanism and increases the engine speed to full throttle. Keep the safety switch pressed all the time the tensioner is engaged and the blade is driven in order to prevent the sawmill operator from getting to the path of the blade. If the safety switch is released the engine stops and it needs to be restarted.
5. To disengage the blade, pull the tensioner handle. This disengages the drive belt and returns the engine to idle. The safety button can be released now, the engine continues to run idle.

3.10 Feed Operation

3.10.1 Standard Manual Feed System

The feed system includes a hand crank to move the carriage forward or backward. The speed at which the carriage travels forward depends on how fast you turn the feed crank.

1. To move the carriage forward, push the crank handle in to engage the screw heads and rotate the feed crank clockwise.

See Figure 3-19.

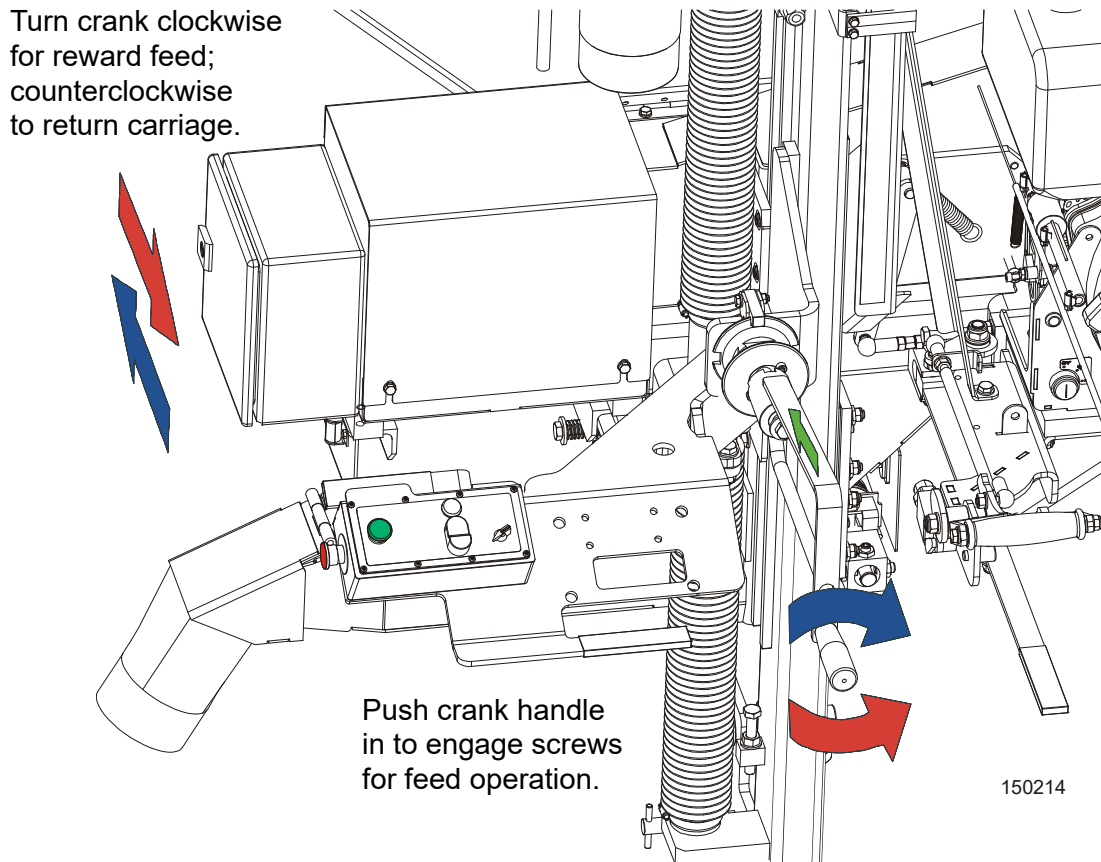


FIG. 3-19

HINT: To get a straight cut in the first part of the board, feed the blade into the log at a slow speed. This stops the blade from flexing and dipping up or down. Use a slow speed until the whole width of the blade has entered the cut. Then increase the feed rate as desired. Maximum feed rate varies with width and hardness of the wood. Over-feeding results in engine and blade wear, and also produces a wavy cut.

2. To move the carriage backward, rotate the feed crank counterclockwise, or pull the saw head back. Always disengage the blade before returning the carriage and raise the carriage slightly to make sure the blade clears the log.

CAUTION! Be sure to stop the blade when returning the carriage. This will not only prevent the blade from being pulled off and ruined by a wood sliver, but also will increase the life of the blade.

3. Make sure that the blade does not catch on the end of the log. Raise the carriage slightly to make sure the blade clears the log when returned.

HINT: Try to stop the blade while the heel of the blade is still on the log. Then bring the carriage back without adjusting the blade up. This lets you keep the blade at the current height setting so you can make the next blade height adjustment more quickly.

3.10.2 Optional Electric Feed System

The feed system includes an electric motor with gear which moves the saw head using a steel strand. The speed at which the saw head travels forward is adjusted by the feed rate switch.

See Figure 3-20.

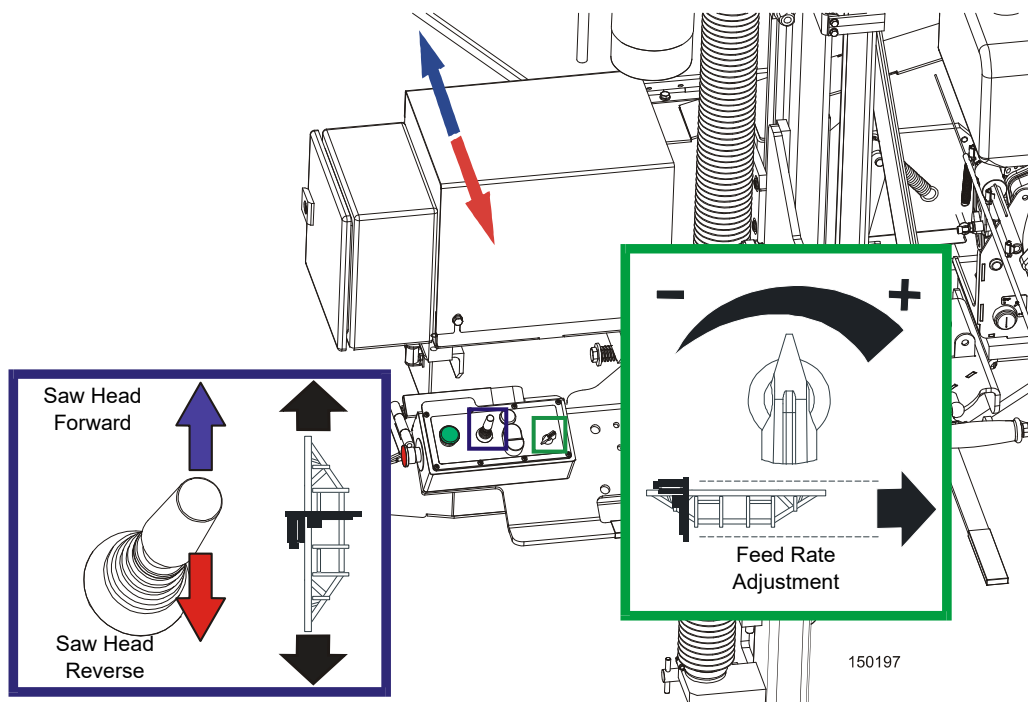





FIG. 3-20

Saw Head Feed Rate

 The saw head feed rate switch controls the speed at which the saw head travels forward. Turn the switch clockwise to increase speed. Turn it counterclockwise to reduce speed. Reverse feed speed is constant.

Saw Head Forward and Reverse

 The power feed switch controls the direction in which the saw head travels. Turn the switch upward to move the saw head forward. Turn the switch down to move the saw head backward.

 **NOTE:** Always disengage the blade before returning the saw head and raise the saw head slightly to make sure the blade clears the log.

Feed Rate

HINT: To get a straight cut in the first part of the log, feed the blade into the log at a slow speed. This stops the blade from flexing and dipping up or down. Turn the saw head feed rate switch to a slow speed until the whole width of the blade has entered the cut. Then use the saw head feed rate



switch to increase the feed rate as desired. Maximum feed rate varies with width and hardness of the wood. Over-feeding results in motor and blade wear, and also produces a wavy cut.

1. Stop the saw head at the end of the cut by turning the saw head feed rate switch counterclockwise until the saw head stops moving.



2. Using the STOP button, disengage the blade. This will stop the blade. Remove the board from the log.

3.11 Cutting The Log

The following steps guide you through normal operation of the Wood-Mizer sawmill.

1. Once the log is placed where you want it and clamped firmly, position the blade close to the end of the log.
2. Use the blade height scale to determine where to make your first cut ([See Section 3.13](#)). The blade height scale will help you to do this. Set the blade to the desired height with the up/down crank. Make sure that the blade will clear all side supports and the clamp. Adjust the outer blade guide to clear the widest section of the log by moving the blade guide arm knob.
3. Make sure all covers and guards are in place. Start the engine. Engage the clutch lever to start the blade spinning.
4. Start the water lube if necessary to prevent sap buildup on the blade. ([See Section 3.14](#).)
5. Feed the blade into the log slowly ([See Section 3.10](#)). Once the blade completely enters the log, increase the feed rate as desired. Always try to cut at the fastest speed you can while keeping an accurate cut. Cutting too slowly will waste blade life and lower production!
6. As you get to the end of the log, slow down the feed rate. When the teeth exit the end of the log, disengage the clutch/brake lever. Remove the slab that you have just cut from the log.
7. Use the feed crank to return the carriage to the front of the mill. Always disengage the blade before returning the carriage for the next cut.
8. Repeat until the first side of the log is cut as desired. Set aside the usable flitches (boards with bark on one or both sides). You can edge them on the mill later.
9. Remove the wedge if it was used. Remove the clamps and turn the log 90 or 180 degrees. Make sure the flat on the log is placed flat against side supports if turned 90 degrees. Make sure it is placed on bed rails if turned 180 degrees. If the log was turned 90 degrees and you are using the wedge to compensate for taper in the log, use the wedge again to adjust the heart of the log parallel with the bed.
10. Repeat the steps used to cut the first side of the log until the log is square. Cut boards from the remaining cant by adjusting the blade height for the thickness of boards that you want.

Example: Remember that the blade cuts a 1/16 - 1/8" (1.6-3.2 mm) wide kerf. If you want 1" (25.4 mm) thick boards, lower the carriage 1 1/16 - 1 1/8" (27-28.6 mm) for each board.

3.12 Edging

The following steps guide you through edging boards on the Wood-Mizer sawmill.

1. Raise the side supports to 1/2 the height of the flitches, or the boards that need to be edged.
2. Stack the flitches on edge against the side supports.
3. Clamp the flitches against the side supports halfway up the flitch height. (Wider flitches should be placed to the clamp side. When they are edged, flip them over to edge the second side without disturbing the other flitches or without having to pull them from the middle of the stack).
4. Adjust the blade height to edge a few of the widest boards.
5. Loosen the clamps and turn the edged boards over to edge the other side.
6. Repeat steps 2-4.
7. Loosen the clamps and remove the boards that have good clean edges on both sides. Clamp the remaining flitches and repeat steps 2-5.

3.13 Blade Height Scale

See Figure 3-21. The blade height scale is attached to the carriage head frame. It includes:

- a blade height indicator
- an inch scale

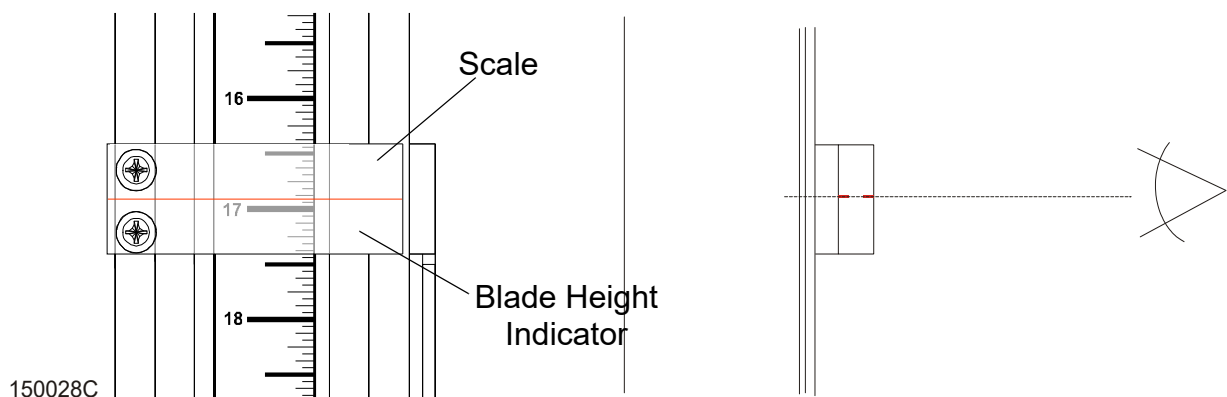


FIG. 3-21

Blade Height Indicator

The blade height indicator has two horizontal, red lines on both sides. Readings should be taken with eyes level with the indicator, when the two red lines are in line. This will allow to avoid the parallax error (different scale readings depending on the angle of vision).

The Inch Scale

The horizontal red line on the blade height indicator shows how many inches the bottom of the blade is above the bed of the mill. If you know the height of your blade at each cut, you can determine the thickness of lumber you are sawing.

Example: You want to cut 1" (25 mm) random width boards from a log. Position the blade for the first cut. Move the carriage to an even measurement on the inch scale. Make a trim cut. Return the carriage for the second cut and lower it 1 1/8" (29 mm) below the original measurement. (The extra 1/8" (3 mm) allows for saw kerf and shrinkage of the lumber.)

The yellow area on the scale identifies where the blade could encounter a side support or log clamp. Check that these items are below the blade level before sawing.

The Quarter Scale

See Table 3-2. The quarter scale contains four sets of marks. Each set represents a specific lumber thickness. Saw kerf and shrinkage allowance are included, but actual board thickness will vary slightly depending on blade thickness and tooth set.

To choose which scale to use, determine what finished thickness you want to end up with. The Grade Hardwood Quarter Scale provides thicker finished boards usually required by commercial buyers. The Standard Quarter Scale allows for kerf and shrinkage of finished boards suitable for most custom applications. Always check with your customer before you saw to determine what actual finished thickness is required.

Standard Quarter Scale		Grade Hardwood Quarter Scale	
Scale	Actual Board Thickness	Scale	Actual Board Thickness
4/4	1" (25 mm)	4/4	1 1/8" (29 mm)
5/4	1 1/4" (32 mm)	5/4	1 3/8" (35 mm)
6/4	1 1/2" (38 mm)	6/4	1 5/8" (41 mm)
8/4	2" (51 mm)	8/4	2 1/8" (54 mm)

TABLE 3-2

To use the quarter scale, look at the blade height indicator. **Example:** You want to cut 1" (25 mm) (4/4) random width boards from a log. Position the blade for the first cut. Make a trim cut. Return the carriage for the second cut. Now, instead of having to measure down 1 1/8" (29 mm) on the inch scale, you can simply lower the blade so the indicator is aligned with the next 4/4 mark on the quarter scale. Turn the log 90 degrees and repeat.

3.14 Water Lube Operation

The optional Water Lube System keeps the blade clean. Water flows from a 5-gallon (18.9 liter) bottle through a hose to the blade guide where the blade enters the log. A valve in the bottle cap controls the amount of water flow.

See Figure 3-22. Install the water bottle bracket at the top of the saw head mast (if the bracket was

3 Setup & Operation

Water Lube Operation

not already welded to the saw head mast).

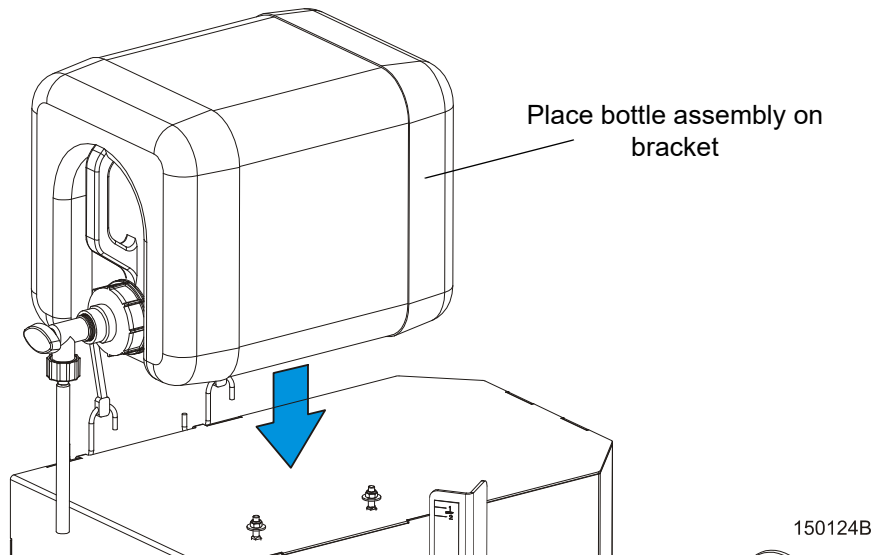


FIG. 3-22

See Figure 3-23. Route the water hose as shown below. Secure it with the provided hose clamps at the locations marked with red points in the figure.

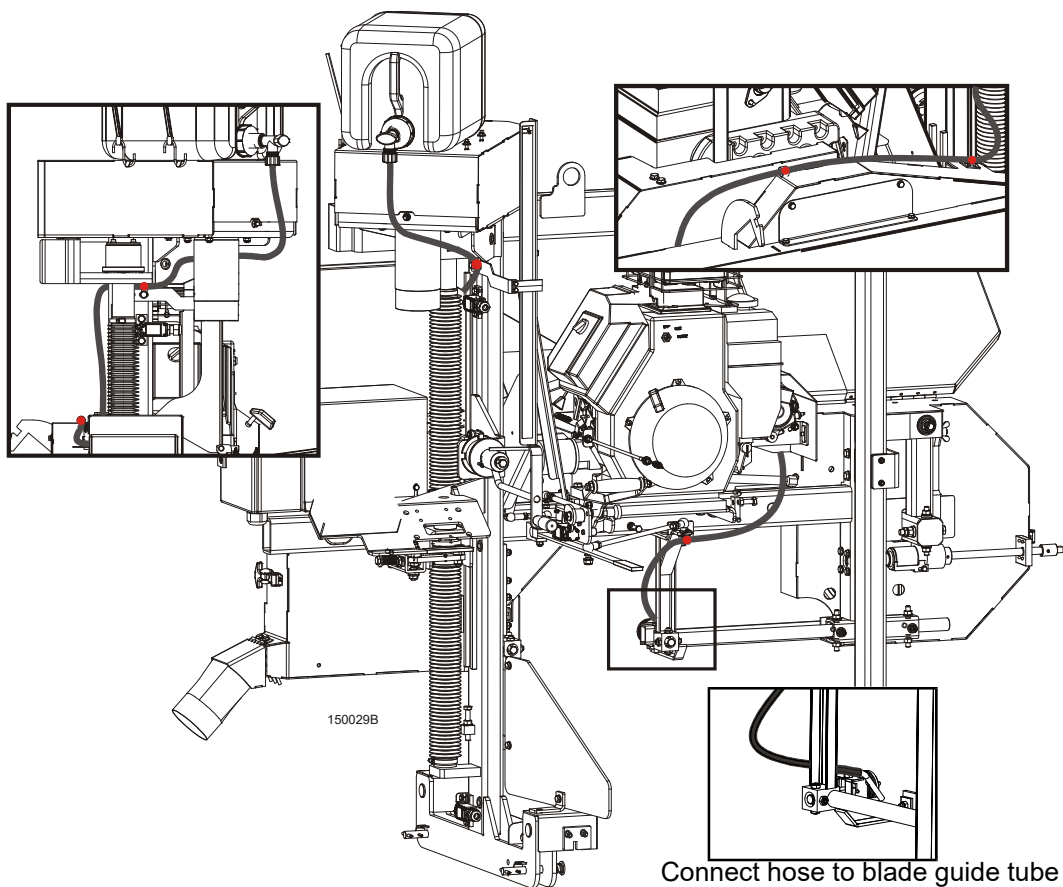


FIG. 3-23

See Figure 3-24. Open the valve on the water bottle to start water flow. A stream of water flows only when the blade is engaged.

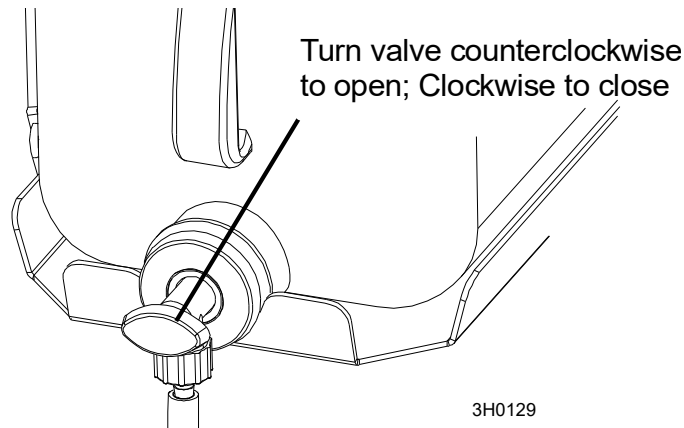



FIG. 3-24

Not all types of wood require the use of the Water Lube System. When it is needed, use just enough water to keep the blade clean. This saves water, and lowers the risk of staining the boards with water. Usual flow will be 1-2 gallons (3.8-7.6 liters) per hour. A squirt of liquid dishwashing detergent in the water bottle will help clean the blade when cutting wood with a high sap content.

 **WARNING!** Use ONLY water with the water lube accessory. Never use flammable fuels or liquids. If these types of liquids are necessary to clean the blade, remove it and clean with a rag. Failure to do so may result in serious injury or death.

Before removing the blade, engage the clutch/brake lever. Let the blade spin with water running on it for about 15 seconds. This will clean the blade of sap buildup. Wipe the blade dry with a rag before storing or sharpening.

If you are sawing in freezing temperatures, remove the water lube bottle from the sawmill when done sawing and store it in a warm place. Blow any remaining water from the water lube hose. To do this, disconnect the water lube hose from the water bottle and engage the blade for about 10 seconds.

3.15 Transporting the Sawmill

The assembled sawmill can be transported in an appropriately equipped pickup truck:

1. Adjust the saw head up just far enough so it will clear the sides of your truck bed when loaded. Do not adjust the saw head so high that the sawmill will tip easily while being loaded.
2. Move the saw carriage to one end of the frame. Engage the travel lock pin to prevent the saw carriage from moving. Pull the pin and rotate and release so the roll pin seats in the locking position notch.

See Figure 3-25.

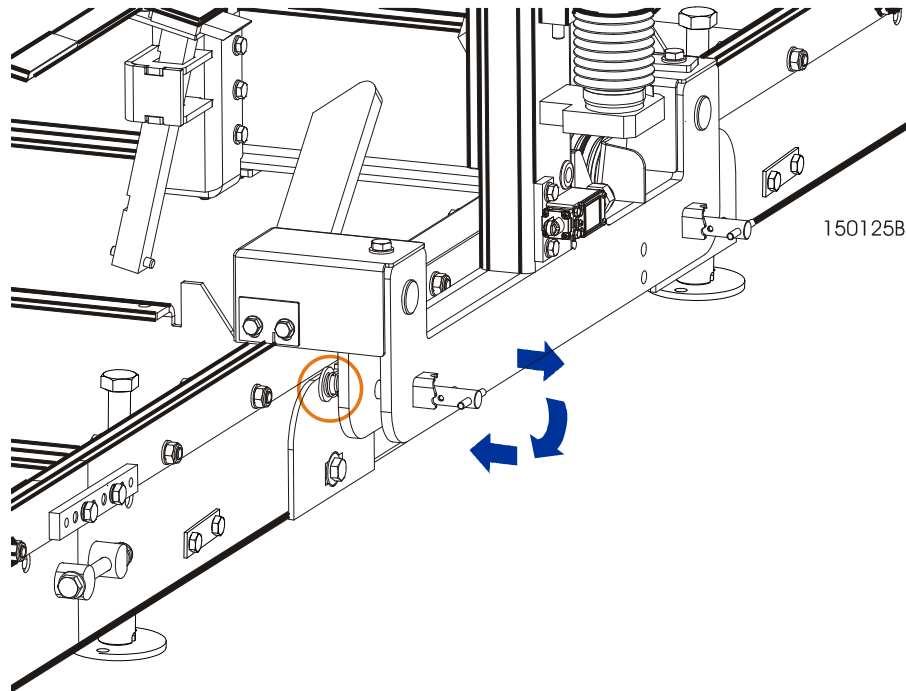


FIG. 3-25

3. Remove the leg assemblies or adjust them above the bottom of the bed frames.
4. Position the bed of the truck at the end of the frame opposite the saw head.
5. While two people lift the end of the frame without the sawhead, back the truck under the sawmill until the the end of the frame is resting firmly on the bed of the truck.
6. With a person positioned on either side of the saw head, disengage the travel lock pin. Push the saw carriage up the bed frame and engage the travel lock pin in the end of the frame in the truck bed.
7. Use two people to lift the end of the mill still on the ground and slide the sawmill into the truck bed.



WARNING! Keep all persons out of the path of the saw head while loading and unloading the sawmill. Failure to do so may result in serious injury or death.

8. Secure the sawmill to the truck bed to prevent the sawmill from shifting while it is being transported.

Wood-Mizer LT15WCSC/LX100/LX450 Short Interval Maintenance Schedule

(Check Engine And Option Manuals For Additional Maintenance Procedures)

PROCEDURE	MANUAL REFERENCE
EVERY BLADE CHANGE	
Check blade guide roller performance	SEE SECTION 4.2
Remove excess sawdust from blade wheel housings and sawdust chute	SEE SECTION 4.2
EVERY 8 HOURS OF OPERATION	
Clean and lubricate track	SEE SECTION 4.3
Remove sawdust from track roller housings	SEE SECTION 4.3

WOOD-MIZER LT15WCSC/LX100/LX450 MAINTENANCE LOG

(Check Engine And Option Manuals For Additional Maintenance Procedures)

PROCEDURE	MANUAL REF- ERENCE	TOTAL HOURS OF OPERATION									
		<i>FILL IN THE DATE AND THE MACHINE HOURS AS YOU PERFORM EACH PROCEDURE. A SHADED BOX INDICATES MAINTENANCE IS NOT NEEDED AT THIS TIME.</i>									
		50 HRS	100 HRS	150 HRS	200 HRS	250 HRS	300 HRS	350 HRS	400 HRS	450 HRS	500 HRS
Clean & lubricate mast	See Section 4.4										
Check blade wheel belts for wear.	See Section 4.6										
Lubricate blade tensioner screw.	See Section 4.5										

WOOD-MIZER LT15WCSC/LX100/LX450 MAINTENANCE LOG

(Check Engine And Option Manuals For Additional Maintenance Procedures)

PROCEDURE	MANUAL REF- ERENCE	TOTAL HOURS OF OPERATION									
		<i>FILL IN THE DATE AND THE MACHINE HOURS AS YOU PERFORM EACH PROCEDURE. A SHADED BOX INDICATES MAINTENANCE IS NOT NEEDED AT THIS TIME.</i>									
		550 HRS	600 HRS	650 HRS	700 HRS	750 HRS	800 HRS	850 HRS	900 HRS	950 HRS	1000 HRS
Clean & lubricate mast	See Section 4.4										
Check blade wheel belts for wear.	See Section 4.6										
Lubricate blade tensioner screw.	See Section 4.5										

WOOD-MIZER LT15WCSC/LX100/LX450 MAINTENANCE LOG

(Check Engine And Option Manuals For Additional Maintenance Procedures)

PROCEDURE	MANUAL REFERENCE	TOTAL HOURS OF OPERATION									
		<i>FILL IN THE DATE AND THE MACHINE HOURS AS YOU PERFORM EACH PROCEDURE. A SHADED BOX INDICATES MAINTENANCE IS NOT NEEDED AT THIS TIME.</i>									
		1050 HRS	1100 HRS	1150 HRS	1200 HRS	1250 HRS	1300 HRS	1350 HRS	1400 HRS	1450 HRS	1500 HRS
Clean & lubricate mast	See Section 4.4										
Check blade wheel belts for wear.	See Section 4.6										
Lubricate blade tensioner screw.	See Section 4.5										

WOOD-MIZER LT15WCSC/LX100/LX450 MAINTENANCE LOG

(Check Engine And Option Manuals For Additional Maintenance Procedures)

PROCEDURE	MANUAL REFERENCE	TOTAL HOURS OF OPERATION									
		<i>FILL IN THE DATE AND THE MACHINE HOURS AS YOU PERFORM EACH PROCEDURE. A SHADED BOX INDICATES MAINTENANCE IS NOT NEEDED AT THIS TIME.</i>									
		1550 HRS	1600 HRS	1650 HRS	1700 HRS	1750 HRS	1800 HRS	1850 HRS	1900 HRS	1950 HRS	2000 HRS
Clean & lubricate mast	See Section 4.4										
Check blade wheel belts for wear.	See Section 4.6										
Lubricate blade tensioner screw.	See Section 4.5										

WOOD-MIZER LT15WCSC/LX100/LX450 MAINTENANCE LOG

(Check Engine And Option Manuals For Additional Maintenance Procedures)

PROCEDURE	MANUAL REF-ERENCE	TOTAL HOURS OF OPERATION									
		<i>FILL IN THE DATE AND THE MACHINE HOURS AS YOU PERFORM EACH PROCEDURE. A SHADED BOX INDICATES MAINTENANCE IS NOT NEEDED AT THIS TIME.</i>									
		2050 HRS	2100 HRS	2150 HRS	2200 HRS	2250 HRS	2300 HRS	2350 HRS	2400 HRS	2450 HRS	2500 HRS
Clean & lubricate mast	See Section 4.4										
Check blade wheel belts for wear.	See Section 4.6										
Lubricate blade tensioner screw.	See Section 4.5										

WOOD-MIZER LT15WCSC/LX100/LX450 MAINTENANCE LOG


(Check Engine And Option Manuals For Additional Maintenance Procedures)

PROCEDURE	MANUAL REF-ERENCE	TOTAL HOURS OF OPERATION									
		<i>FILL IN THE DATE AND THE MACHINE HOURS AS YOU PERFORM EACH PROCEDURE. A SHADED BOX INDICATES MAINTENANCE IS NOT NEEDED AT THIS TIME.</i>									
		2550 HRS	2600 HRS	2650 HRS	2700 HRS	2750 HRS	2800 HRS	2850 HRS	2900 HRS	2950 HRS	3000 HRS
Clean & lubricate mast	See Section 4.4										
Check blade wheel belts for wear.	See Section 4.6										
Lubricate blade tensioner screw.	See Section 4.5										

SECTION 4 MAINTENANCE

This section lists the maintenance procedures that need to be performed.

The Short Interval Maintenance Schedule lists procedures that need to be performed every 4, 8 or 25 hours. The Maintenance Log lists procedures that need to be performed every 50, 100, 200, or 1000 hours. Keep track of machine maintenance by filling in the machine hours and the date you perform each procedure.

 **This symbol** identifies the interval (hours of operation) at which each maintenance procedure should be performed.

Be sure to refer to option and engine manuals for other maintenance procedures.

4.1 Wear Life

See Table 4-1. This chart lists estimated life expectancy of common replacement parts if proper maintenance and operation procedures are followed. Due to the many variables which exist during sawmill operation, actual part life may vary significantly. This information is provided so that you may plan ahead in ordering replacement parts.

Part Description	Estimated Life
B57 Blade Wheel Belts	500 hours
Blade Guide Rollers	1000 hours
Drive Belt	1250 hours
Power Feed System Steel Strand	500 hours



TABLE 4-1

4.2 Sawdust Removal

Remove the excess sawdust from the blade wheel housings and sawdust chute every blade change.

4.3 Carriage Track & Rollers

See Figure 4-1.

-  **1.** Clean the track rails to remove any sawdust and sap buildup every eight hours of operation.
-  **2.** Remove sawdust from the track roller housings. Remove the track roller housing covers and brush

any sawdust buildup from the housings.

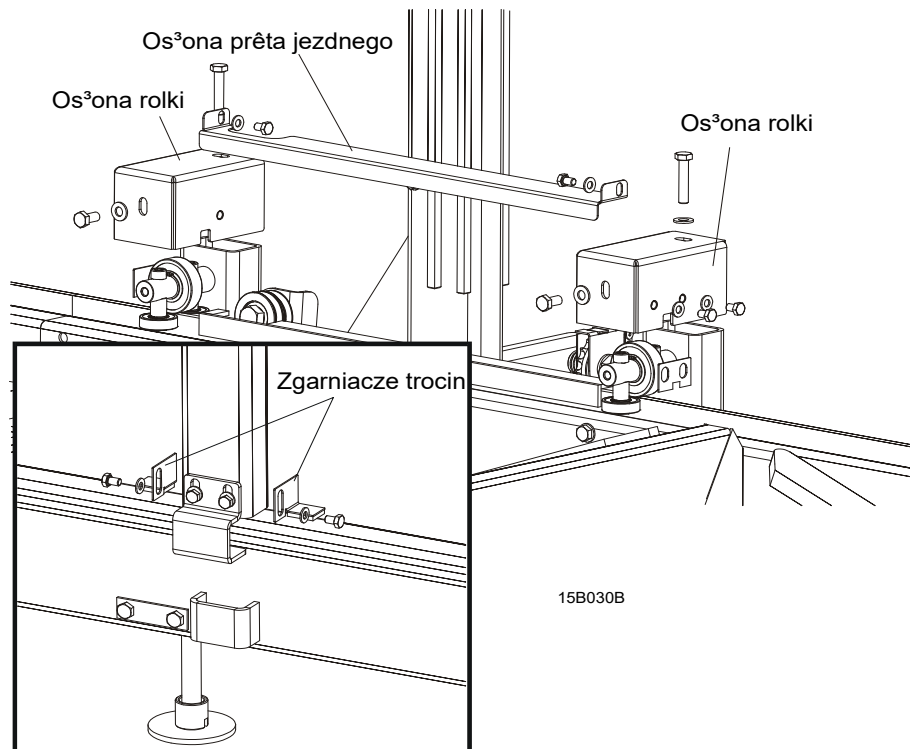


FIG. 4-1

4.4 Vertical Mast Rails

50 Clean and lubricate the vertical mast rails every 50 hours of operation. Clean with solvent and remove any rust with a light-grade sand paper or emery cloth. Lubricate the mast with motor oil or automatic transmission fluid (ATF).



CAUTION! Never use grease on the mast rails as it will collect sawdust.

4.5 Miscellaneous Lubrication

50 1. Oil all chains with Dexron III ATF every fifty hours of operation.



CAUTION! Do not use chain lube. It causes sawdust buildup in chain links.

2. Lubricate the tensioner screw with a NLGI No. 2 grade lithium grease as needed.

See Figure 4-2.

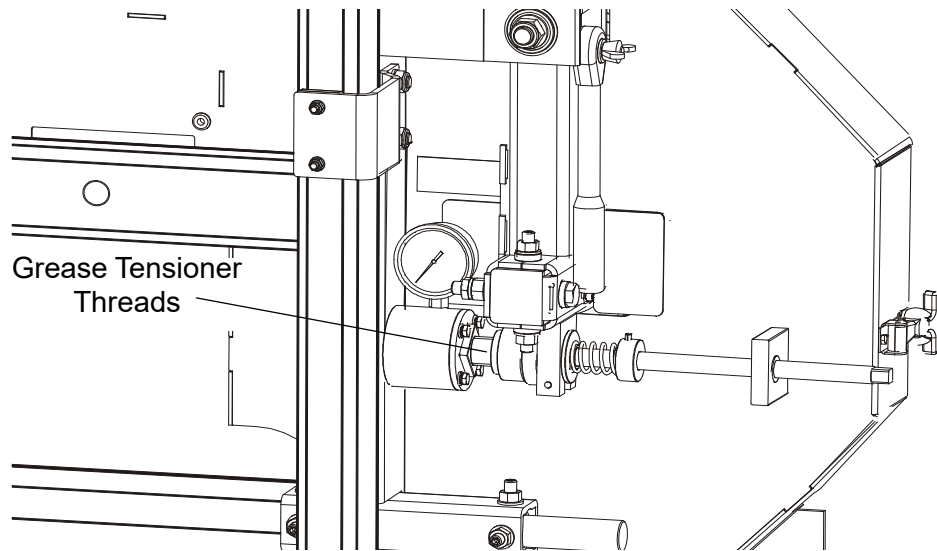


FIG. 4-2

4.6 Blade Wheel Belts

1. Rotate the blade wheel belts and check them for wear. Rotating the belts every 50 hours will give you longer belt life. Replace belts as necessary. Use only B57 belts manufactured by Goodyear or Browning.
2. Periodically check all belts for wear. Replace any damaged or worn belts as needed.

4.7 Brake Pads Adjustment (Gas / Diesel Sawmills Only)

200

Check the brake pads for wear every 200 hours of operation. Replace if damaged or worn.

Adjust the brake pads if the blade does not stop quickly, unusual sounds occur when the brake is applied, or a sudden change is noticed in the clutch/brake lever position when the clutch is disengaged.



WARNING! Do not for any reason adjust the brake pads with the engine running. Doing so may result in serious injury.

Open the blade housing cover.

See **Figure 4-1**. Loosen the locking bolts shown below. Adjust the brake pads so the blade stops no later than 10 seconds after disengaging. The brake pads should enter the grooves in the drive pulley when the brake is applied. If they are not, it can lead to their premature wear.

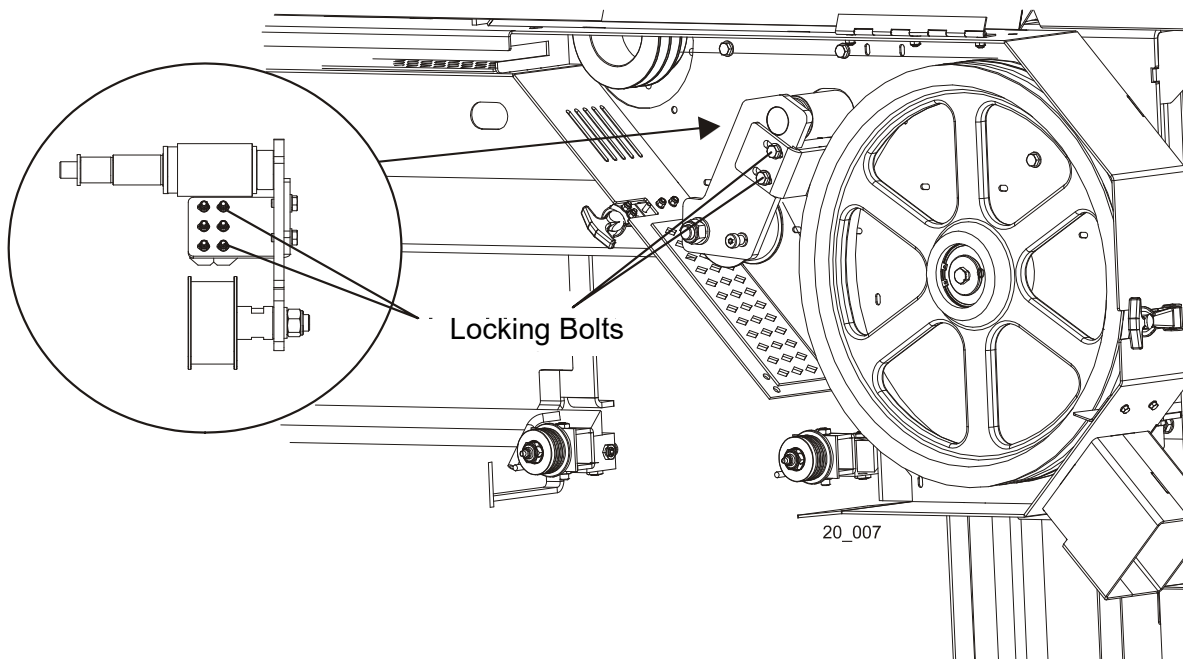


FIG. 4-1

4.8 Up/Down System

1. Remove any sawdust buildup from the up/down screw bellows, the up/down screw nut, the upper and lower limit switches and the lower bearing housing.

See Figure 4-3.

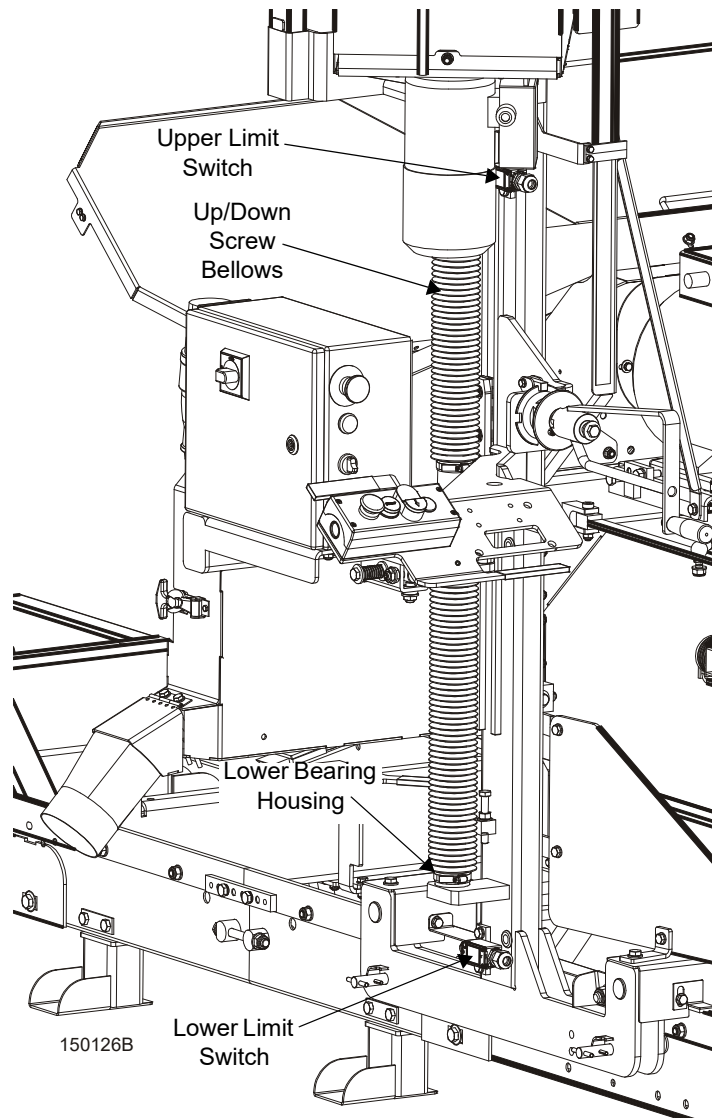


FIG. 4-1

2. Lubricate the up/down acme screw with a rolling bearing lubricant (e.g. LT4S or Shell Extreme Pressure Grease) every six months. Apply the lubricant to the grease fitting in the nut housing. Lubrication may be required sooner if environmental conditions require it. If the lubricant appears to have dispersed or is dry or crusted, reduce the maintenance interval.

The up/down screw bellows should completely cover the screw. If either of the bellows is damaged, replace it immediately. Before installing the new bellows, clean the up/down screw and nut thoroughly with extraction naphtha. The acme screw nut (Part No. 094243) should be replaced if the end play is larger than 1.25 mm.

3. Check the up/down belt tension after the first 20 hours of operation and every 100 hours thereafter.

See **Figure 4-4**. Unbolt the up/down top guard. Loosen the motor mounting bolts. Use the adjustment bolt shown below to adjust the belt tension. Tighten the motor mounting bolts. Replace the top guard.

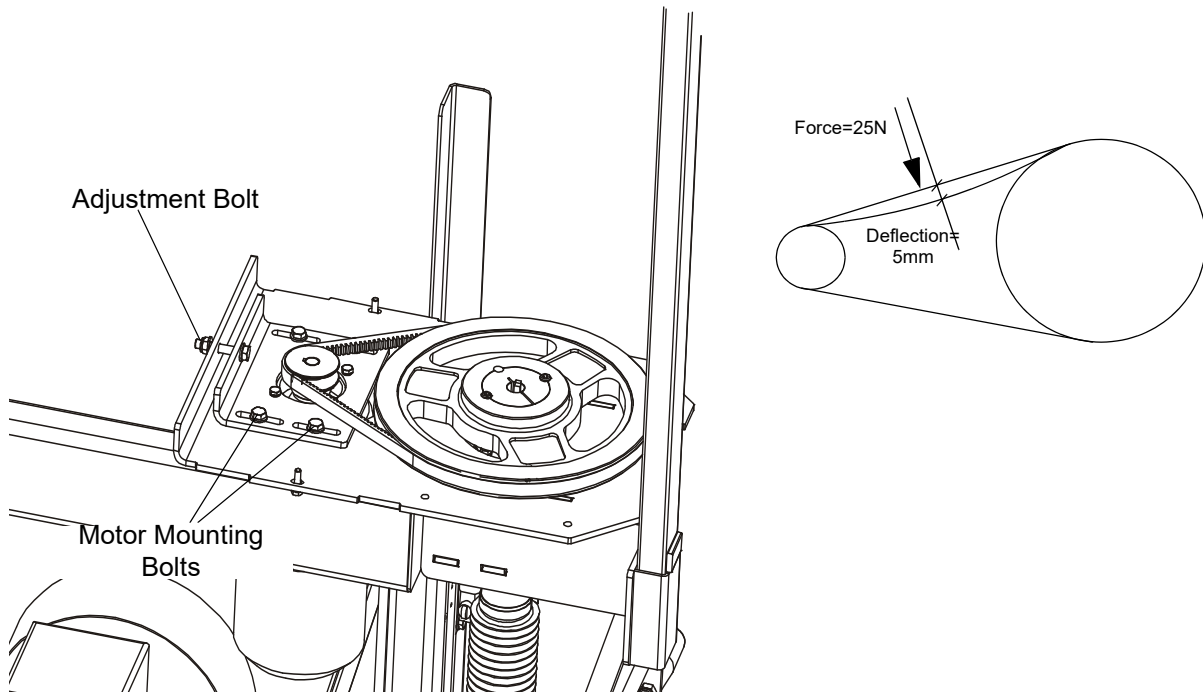


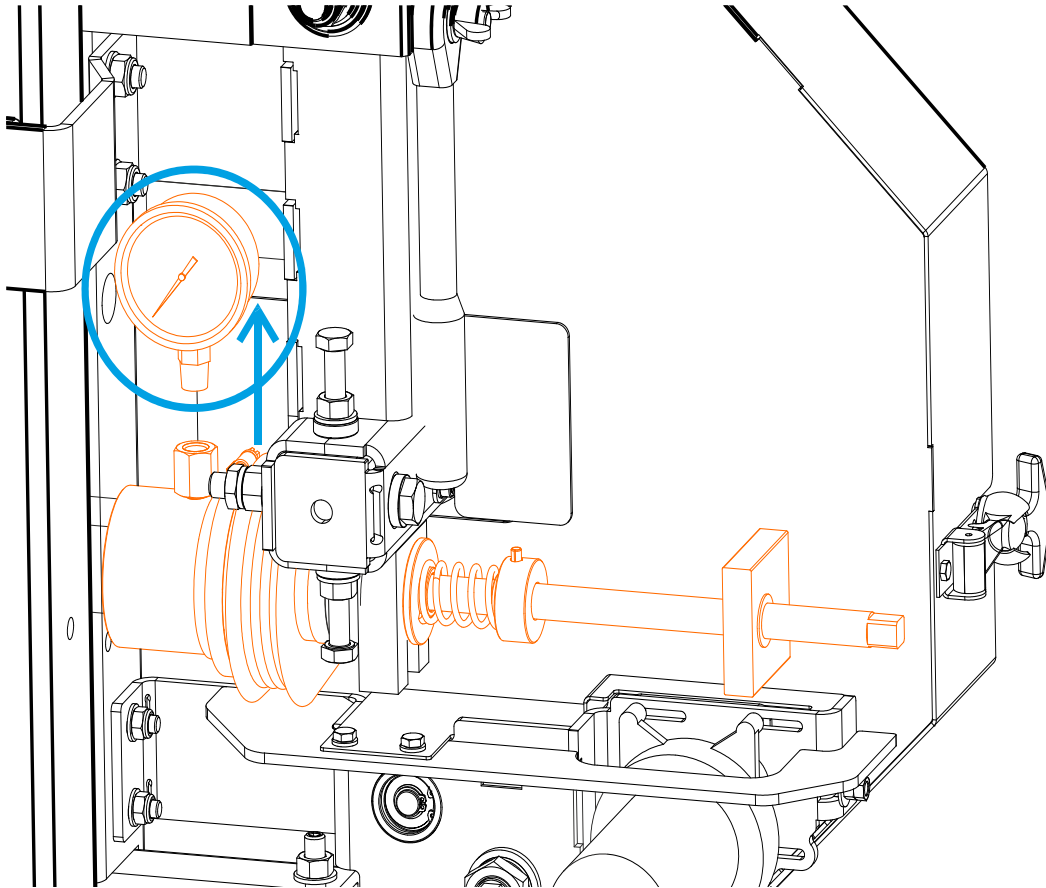
FIG. 4-2

4.9 Miscellaneous Maintenance

- 50
 1. Check the drive belt tension after the first 20 hours, and every 50 hours thereafter. Drive belt adjustment differs according to the specified motor or engine. See the Wood-Mizer Motor or Engine Option manual supplied with your mill for specific adjustment instructions.
2. Check the mill alignment every setup. See Section 6, Alignment.
3. If the clutch begins to slip, adjust the turnbuckle linkage. Turn the turnbuckle clockwise (as viewed from the top) to provide 46 lbs. of tension.
4. Make sure all safety warning decals are readable. Remove sawdust and dirt. Replace any damaged or unreadable decals immediately. Order decals from your Customer Service Representative
- 500
 5. Check the power feed system steel strand every 50 hours, replace it every 500 hours.

4.10 Filling Blade Tensioner Cylinder with Oil

1. Loosen the blade tensioner completely.
2. Unscrew the oil pressure gauge.



3. Using an oiler equipped with a tube / hose, top up the oil level until the oil flows out of the cylinder.

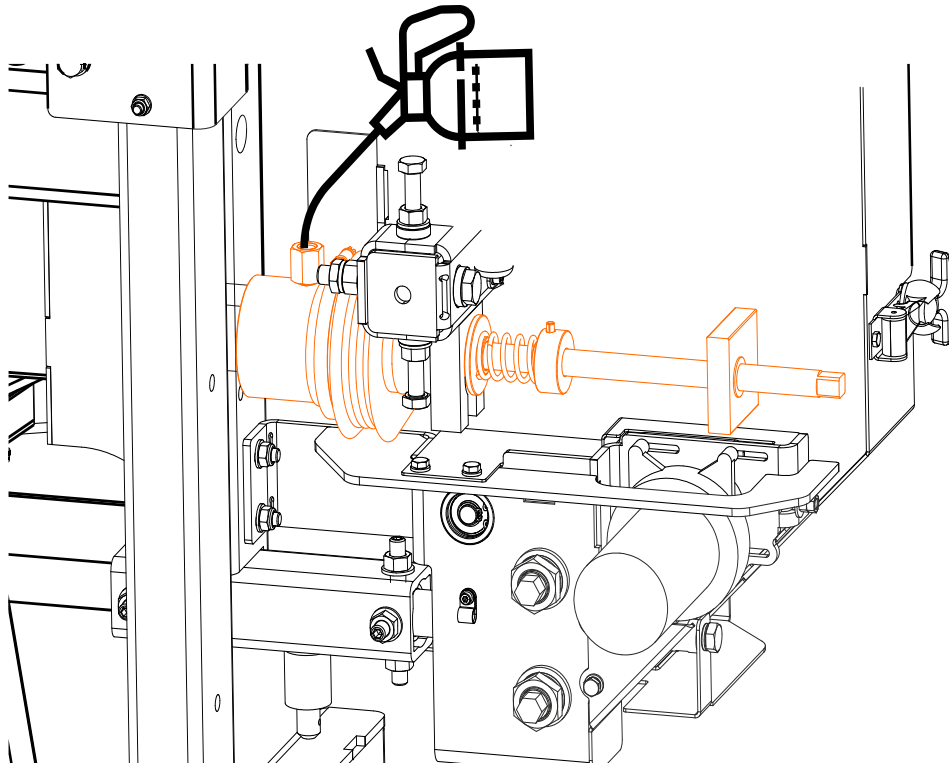


IMPORTANT! The cylinder needs to be filled with MOBIL DTE 10 Excel 32 Hydraulic Oil (#WM part number: **P12825**).

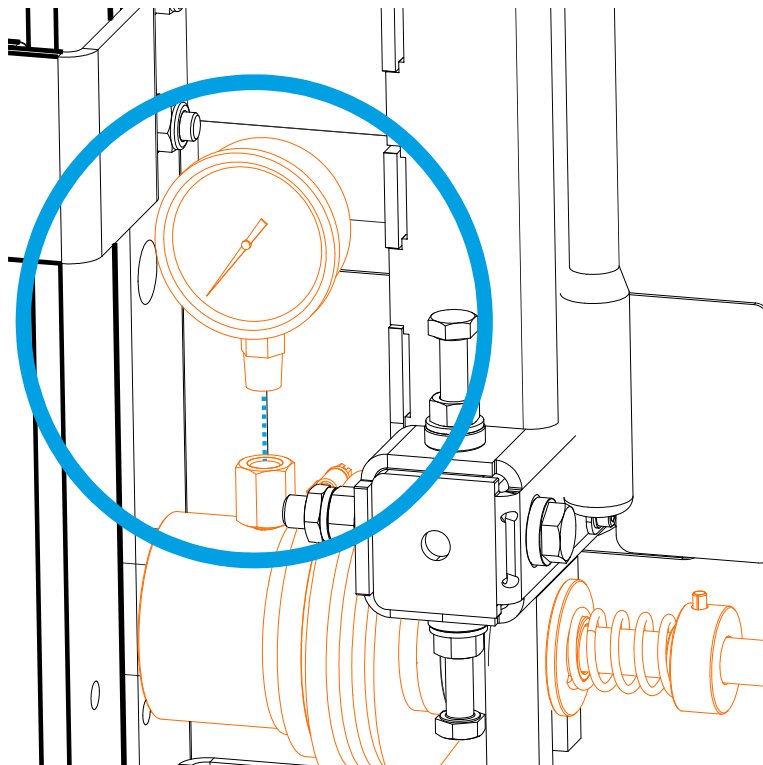


IMPORTANT! When topping up the oil level, make sure that the end of the oiler tube / hose is at the bottom of the cylinder.

4. Wait 5 minutes. If the oil level does not lower, move on to the next step. If the oil level lowers, top up the oil level until the oil flows out of the cylinder.



5. Seal the oil pressure gauge with Teflon tape and screw it back.



4.11 Safety Devices Inspection (CE version only)

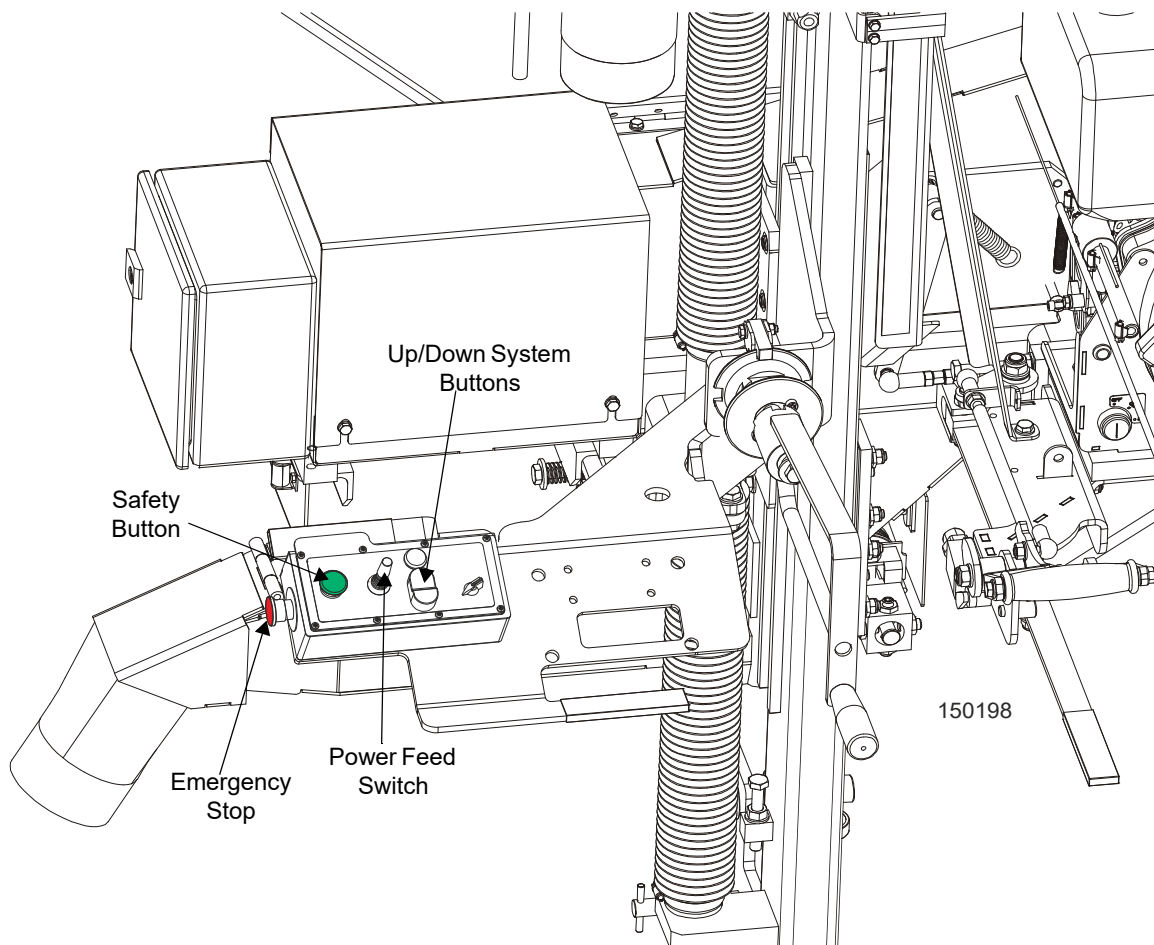
LT15 DC – Safety Devices Inspection

Safety devices on the LT15DC machine which must be checked before every shift:

- E-STOP button and its circuit inspection
- Green safety button inspection
- Inspection of the control circuits with the E-STOP button pressed
- Inspection of the tensioner handle safety switch
- Blade cover safety switch and its circuit inspection.

1. E-STOP button and its circuit inspection

- Start the engine according to your engine option manual;
- Press and hold the green safety button;
- Push the tensioner handle forward to engage the blade;
- Press the E-STOP button located on the left side of the control box. The engine should be stopped. Restarting the engine should not be possible until the E-STOP button is released.



2. Green safety button inspection

- Be sure the E-STOP button is released;
- Start the engine according to your engine option manual;
- Press and hold the green safety button;
- Push the tensioner handle forward to engage the blade;
- Release the safety button. The engine should be stopped.
- Press and hold the green safety button. The engine should remain stopped.

3. Inspection of the control circuits with the E-STOP button pressed

- Start the engine according to your engine option manual;
- Press and hold the green safety button;
- Push the tensioner handle forward to engage the blade;
- Press the E-STOP button located on the left side of the control box. The engine should be stopped.
- With the E-STOP button pressed, try to move the saw head up and down (using the switch and the Setworks buttons) and forward/backward using the power feed switch. Both systems should not start.

4. Inspection of the tensioner handle safety switch

- Start the engine according to your engine option manual;
- Push the tensioner handle forward to engage the blade;
- The engine should be stopped.

5. Blade cover safety switch and its circuit inspection

- Start the engine according to your engine option manual;
- Press and hold the green safety button;
- Push the tensioner handle forward to engage the blade;
- Open the blade housing cover;
- The engine should be stopped.

SECTION 5 TROUBLESHOOTING GUIDE

5.1 Sawing Problems

PROBLEM	CAUSE	SOLUTION
Blades Dull Quickly.	Dirty logs	Clean or debark logs, especially on entry side of the cut.
	When grinding teeth, heating too much and causing teeth to soften	Grind just enough metal to restore sharpness to the teeth. Use water/coolant while sharpening blade.
	Poor sharpening techniques	Make sure the tip is being sharpened completely (See Sharpener Manual).
Blades Break Prematurely.	Rubber belts on blade wheels worn to a point that blade contacts metal pulley - look for shiny spots on edge of wheels.	Change blade wheel belts (B-57).
	Poor sharpening techniques	See Sharpener Manual.
	Tension too tight	Tension blade to recommended specifications.
Blade Does Not Track Right on Drive Wheel.	Cant adjustment is incorrect.	Readjust.
	Flat/worn belts	Replace B-57 belts.
Blade Guides Do Not Spin While Cutting.	Frozen bearings	Replace bearings.
	Stiff bearings	Grease bearings.
Drive Belts Wear Prematurely or Jump.	Engine/motor and drive pulleys out of alignment.	Align pulleys.

PROBLEM	CAUSE	SOLUTION
Boards Thick Or Thin On Ends Or Middle Of Board	Stress in log which causes log to not lay flat on the bed	After log has been squared, take equal cuts off opposing sides. Take a board off the top. Turn the log 180 degrees. Take a board off. Repeat, keeping the heart in the middle of the cant, and making it your last cut.
	Set in teeth	Resharpener and reset blade.
Height Adjustment Jumps or Stutters When Moving Up or Down	Bed rails misaligned	Realign sawmill.
	Mast needs lubrication	Lubricate mast track surface.
Lumber Is Not Square	Up/Down Screw needs lubrication.	Lubricate Up/Down Screw.
	Vertical wear pads are too tight	Adjust pads.
	Vertical side supports not square to bed	Adjust side supports.
Sawdust Builds Up On Track	Blade not parallel to bed rails	Adjust bed rails parallel to blade.
	Sawdust or bark between cant and bed rails	Remove particles.
Wavy Cuts	Tooth set problems	Resharpener and reset blade.
	Excessive oiling	Do not oil track.
Wavy Cuts	Track is sticky	Clean track with solvent and apply silicone spray.
	Excessive feed	Slow feed rate
	Improperly sharpened blade (This will be the problem 99% of the time!)	Resharpener blade. (See Sharpener Manual - read entire manual!)
Wavy Cuts	Blade guides improperly adjusted	Adjust blade guides.
	Sap buildup on blade	Use Water Lube.
	Tooth set problem	Resharpener and reset blade.

SECTION 6 ALIGNMENT

6.1 Pre-Alignment Procedures

Periodically check the sawmill alignment and adjust if necessary. This chapter explains how to align the entire sawmill. Care should be taken in performing these steps. Sawmill alignment determines the accuracy and squareness of your cuts.

The sawmill alignment steps are:

1. Ready the sawmill for alignment
2. Adjust the blade parallel to the bed rails
3. Adjust the blade guide arm parallel to the saw head brace
4. Align blade guides to the blade
5. Adjust side supports square to the bed
6. Final Adjustments

To insure accurate alignment, the sawmill frame must be level and a blade properly installed.

[See SECTION 3 Setup & Operation](#) for setup information.

6.2 Preparing The Sawmill For Alignment

Before performing the following alignment procedures, setup the mill on firm, level ground. String the bed and adjust the legs so the frame is level as described in [Section 3.1](#).

6.3 Blade Installation and Alignment

Install a blade and apply the appropriate tension as shown in [Section 3.3](#).

1. Raise the middle blade housing cover and make sure all persons are clear of the open side of the saw head.
2. Start the engine.
3. Pull lightly on the clutch handle, rotating the blade until the blade positions itself on the wheels.



WARNING! Do not spin the blade wheels by hand. Spinning the blade wheels by hand may result in serious injury.

4. Release the clutch handle to stop the blade. Turn off the engine, remove the key and check the position of the blade on the blade wheels.

Check the vertical alignment of the idle-side blade wheel. The gullet of the blade should ride the same distance from the front edge of the wheel at the top and bottom of the wheel. If it does not, loosen and tighten the appropriate adjustment screws on the wheel shaft.

See Figure 6-1. The blade wheels should be adjusted so that the gullet of 1 1/4" blades ride 1/8" (3 mm) out from the front edge of the wheels ($\pm 1/26$ [1 mm]). The gullet of 1 1/2" blades should ride 3/16" (4.5 mm) from the front edge of the wheels ($\pm 1/26$ [1 mm]). Do not let the teeth ride on the wheels.

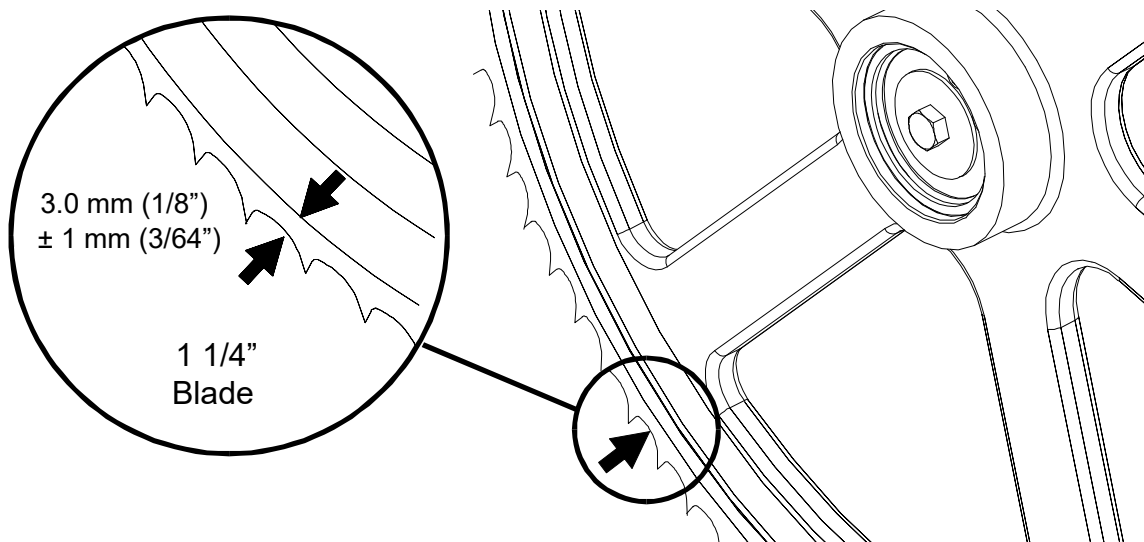


FIG. 6-1

To adjust where the blade travels on the idle-side and drive-side blade wheel, [See Section 6.4](#).

6.4 Blade Wheel Alignment

The blade wheels should be adjusted so they are level in the vertical and horizontal planes. If the blade wheels are tilted up or down, the blade will want to travel in the tilted direction. If the blade wheels are tilted horizontally, the blade will not track properly on the wheels.

1. Use the blade guide alignment tool to check the vertical alignment of each blade wheel. Attach the tool to the blade near the inner blade guide mount. Be sure the tool does not rest on a tooth or burr, and is lying flat against the bottom of the blade.

See Figure 6-2.

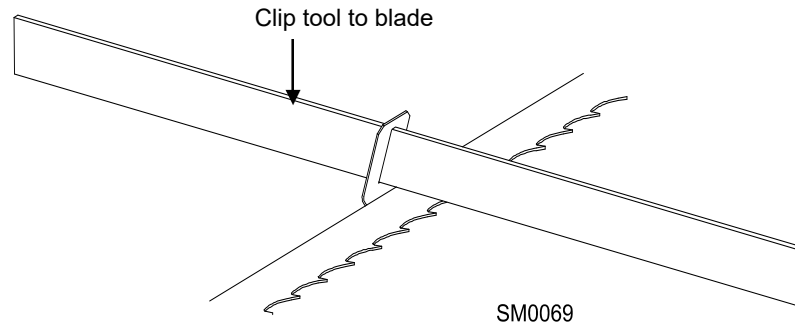
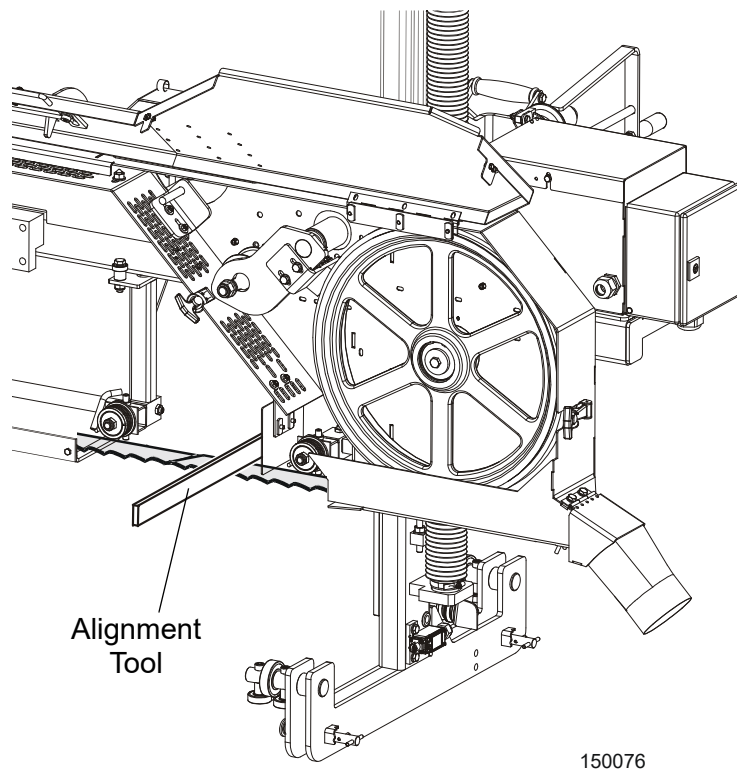


FIG. 6-2

2. Move the saw carriage so the front end of the tool is positioned over the first bed rail. Measure from the bottom of the tool to the top surface of the bed rail.
3. Move the saw carriage so the rear of the tool is positioned over the bed rail. Again, measure from the bottom of the tool to the bed rail.
4. If the two measurements differ by more than 1/16" (1.5 mm), adjust the vertical tilt of the drive-side blade wheel.

See Figure 6-3. Use the vertical adjustment screws to adjust the drive-side blade wheel. To tilt the wheel, loosen the top adjustment screw one quarter turn. Loosen the jam nut on the bottom adjustment screw and tighten the screw. Tighten the top and bottom jam nuts.

To tilt the wheel, loosen the bottom adjustment screw one quarter turn. Loosen the jam nut on the top adjustment screw and tighten the screw. Tighten the top and bottom jam nuts.



To tilt wheel up, tighten top screw (loosening earlier bottom screw). To tilt wheel down, tighten bottom screw (loosening earlier top screw).

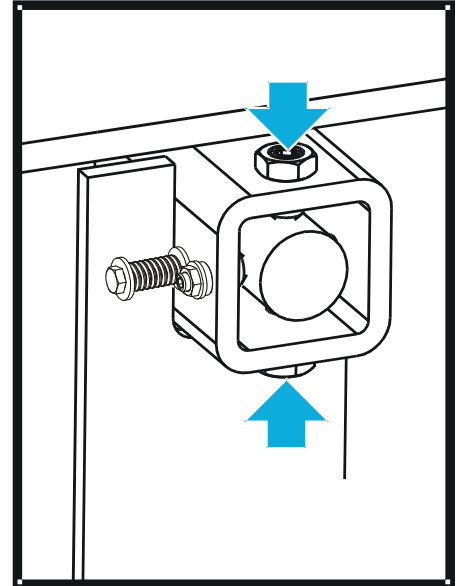


FIG. 6-3

5. Recheck the vertical tilt of the drive-side blade wheel with the blade guide alignment tool. Readjust the blade wheel as necessary until the front and rear of the tool are the same distance from the bed rail (within 1/16" [1.5 mm]).
6. Remove the tool from the blade and reattach it near the outer blade guide assembly.
7. Measure from the tool to the bed rail at both ends of the tool. If the measurements at the front and rear ends of the tool differ by more than 1/16" (1.5 mm), adjust the vertical tilt of the idle-side blade wheel.

See Figure 6-4. Use the vertical adjustment screws to adjust the idle-side blade wheel. To tilt the wheel up, loosen the bottom adjustment screw one quarter turn. Loosen the jam nut on the top adjustment screw and tighten the screw. Tighten the top and bottom jam nuts.

To tilt the wheel down, loosen the top adjustment screw one quarter turn. Loosen the jam nut on the bottom adjustment screw and tighten the screw. Tighten the top and bottom jam nuts.

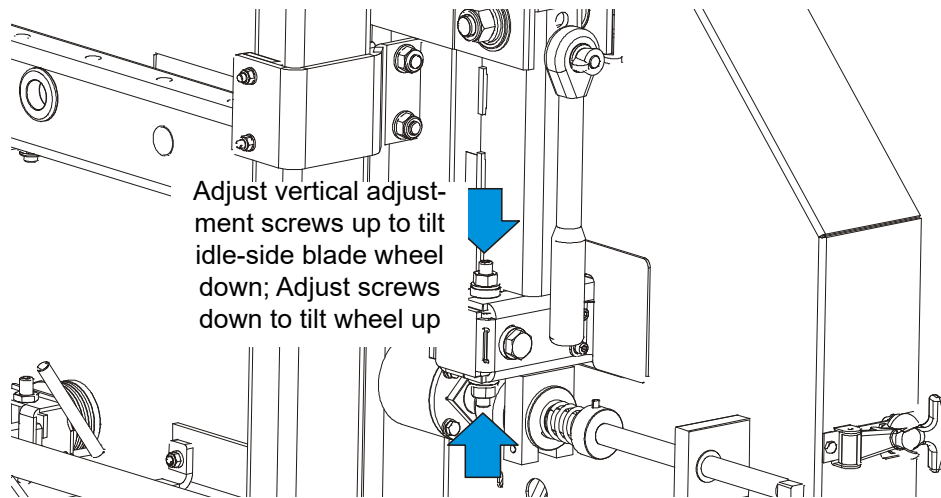


FIG. 6-4

8. Recheck the vertical tilt of the idle-side blade wheel with the blade guide alignment tool. Readjust the blade wheel as necessary until the front and rear of the tool are the same distance from the bed rail (within 1/16" [1.5 mm]).
9. Check the position of the blade on the idle-side blade wheel.

See Figure 6-5. The horizontal tilt of the blade wheel should be adjusted so that the gullet of an 1-1/4" blade is 1/8" (3 mm) out from the front edge of the wheel ($\pm 1/32$ [0.75 mm]).

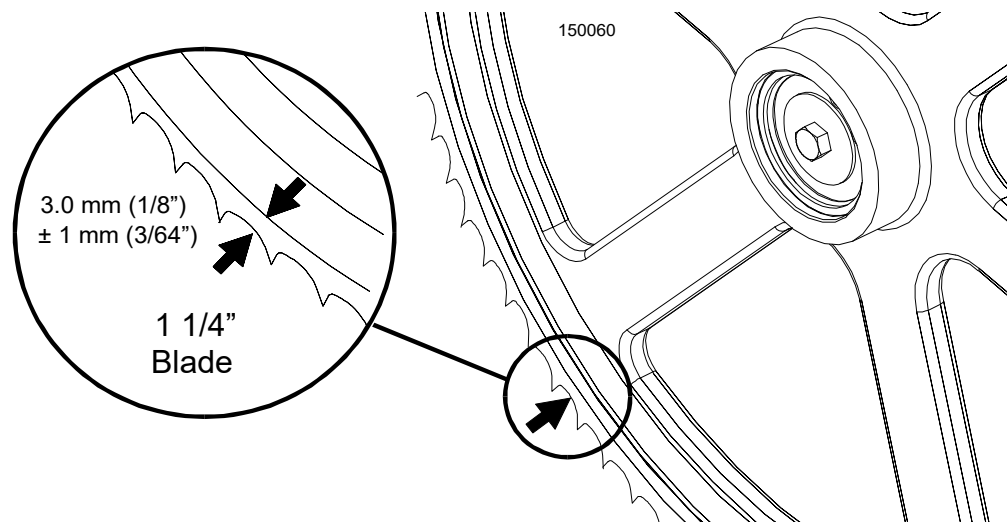
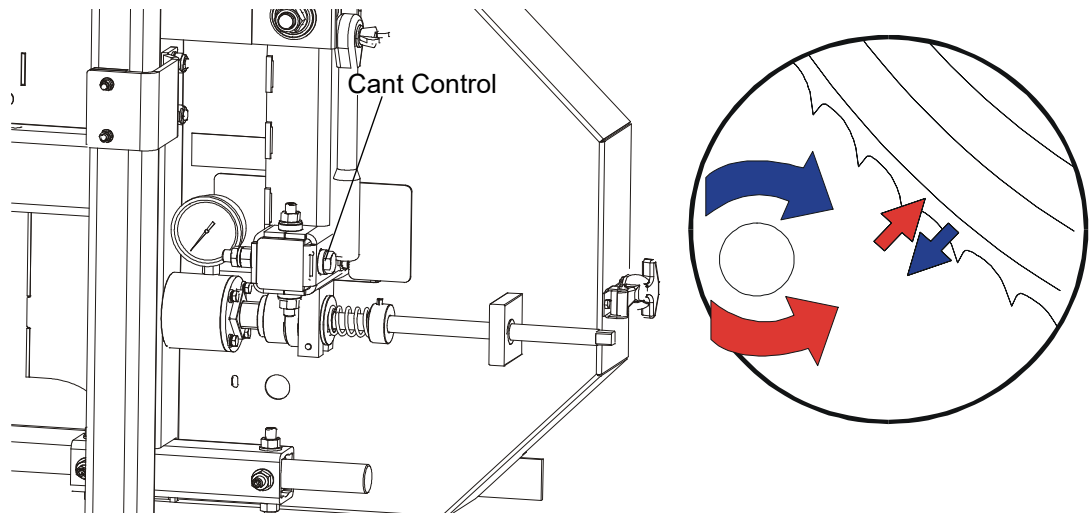


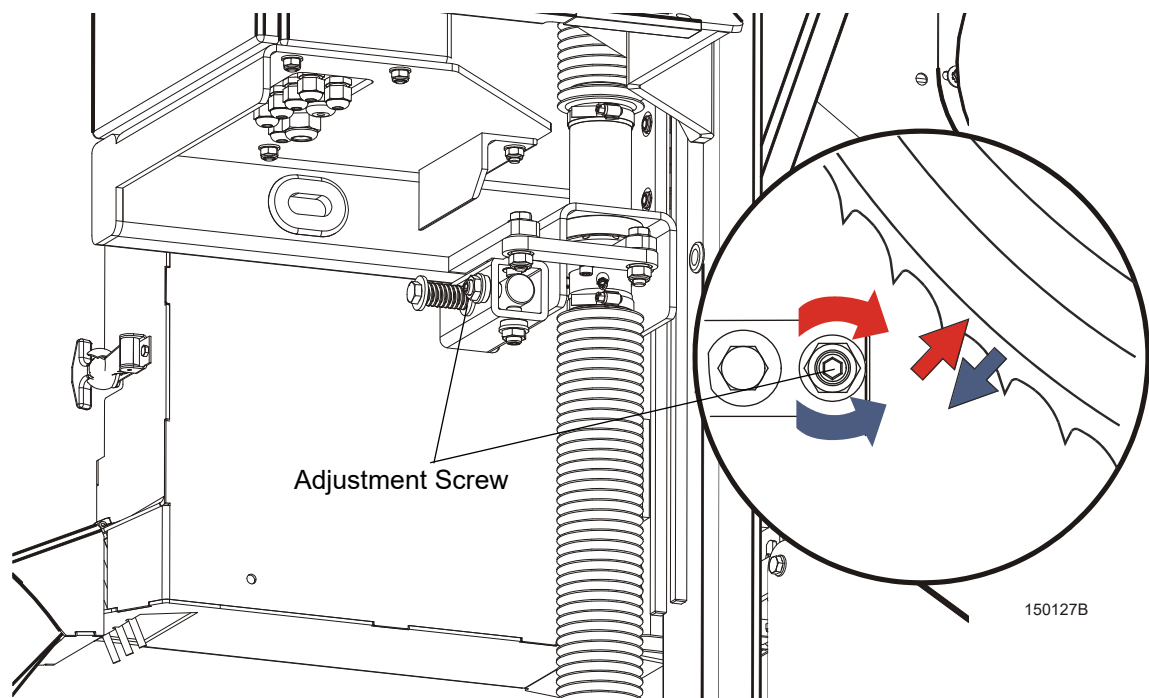
FIG. 6-5

See Figure 6-6. Use the cant control adjustment to adjust the idle-side blade wheel. If the blade is too far forward on the wheel, turn the cant control counterclockwise. If it is too far back on the wheel, turn the cant control clockwise.

**FIG. 6-6**

10. Check the position of the blade on the drive-side blade wheel. The blade should be positioned on the wheel as described for the idle-side blade wheel. Adjust the drive-side blade wheel if necessary.

See Figure 6-7. Use the horizontal adjustment screw to adjust the drive-side blade wheel. Loosen the jam nut on the adjustment screw. Loosen adjustment screw to move blade out on wheel. Tighten adjustment screw to move blade in on wheel. Tighten the jam nut.

**FIG. 6-7**

NOTE: It is not necessary to align the spring bolt (bolt M10x75 [WM# F81003-15] + spring + washer) shown in the figure above. When replacing the bolt or spring, just screw in the bolt completely.

6.5 Blade Guide Arm Alignment

Before aligning the blade guide arm, track the blade on the blade wheels as described in [Section 3.4](#). Move the carriage so the blade is positioned over the first bed rail. Level the blade to the bed rail as shown in [Section 3.1](#). Adjust the blade guide rollers so they do not touch the blade.

Vertical Alignment

1. Adjust the blade guide arm all the way out away from the other blade guide (maximum distance between the guide rollers).

See Figure 6-8.

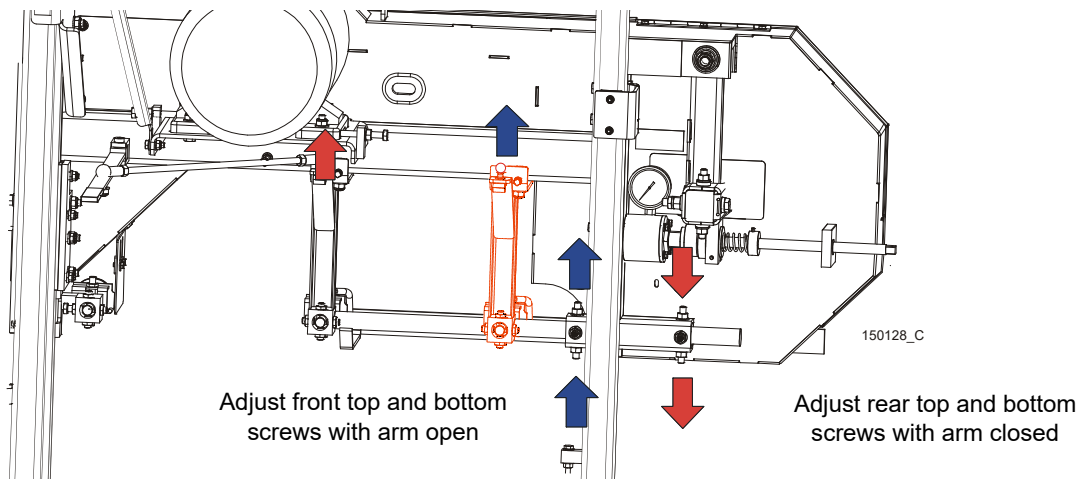


FIG. 6-8

2. Use the arm adjustment screws, marked with blue arrows in the figure above, to adjust the arm up until the slide pad touches the saw head brace tube. Tighten the jam nuts.
3. Adjust the blade guide arm in all the way toward the other blade guide (minimum distance between the guide rollers).
4. Use the arm adjustment screws, marked with red arrows in the figure above, to adjust the arm up until the slide pad touches the saw head brace tube. Tighten the jam nuts.

NOTE: When adjusting the blade guide arm screws, be careful not to tighten the screws too much or put the arm in a bind. Operate the blade guide arm knob to ensure the arm moves easily in and out when the knob is turned.

Horizontal Alignment

See Figure 6-9.

1. With the blade guide arm still all the way in toward the other blade guide, tighten all the side screws until they touch the arm. Back the screws off 1/4 turn and tighten the jam nuts.
2. Sight across the horizontal saw head brace to view the blade guide arm. Adjust all side screws on the blade guide arm housing so the arm is parallel to the saw head brace.
3. To move the blade guide end of the arm toward the front of the sawmill, loosen jam nuts on the front inside screw and the rear outside screw. Turn the screws counterclockwise one full turn and tighten the jam nuts. Loosen the jam nuts on the front outside screw and the rear inside screw. Turn the screws clockwise until they touch the arm, back off 1/4" turn, and tighten the jam nuts.
4. To move the blade guide end of the arm toward the rear of the sawmill, loosen jam nuts on the front outside screw and the rear inside screw. Turn the screws counterclockwise one full turn and tighten the jam nuts. Loosen the jam nuts on the front inside screw and the rear outside screw. Turn the screws clockwise until they touch the arm, back off 1/4" turn, and tighten the jam nuts.

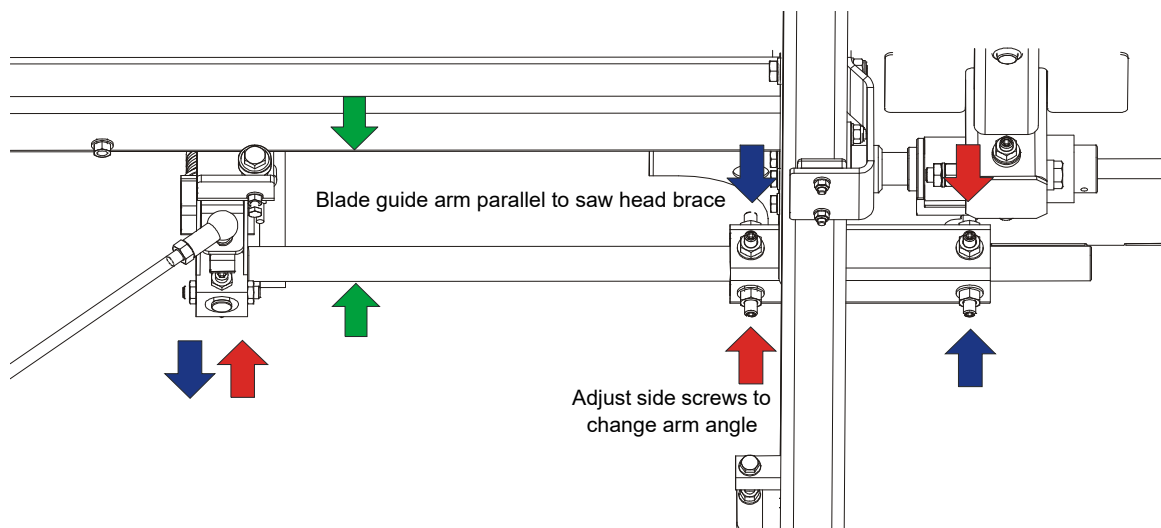


FIG. 6-9

6.6 Aligning The Blade Guides

Each Wood-Mizer sawmill has two blade guide assemblies that help the blade maintain a straight cut. The two blade guide assemblies are positioned on the saw head to guide the blade on each side of the material being cut.

One blade guide assembly is mounted in a stationary position on the drive side of the saw head. This assembly is referred to as the "inner" blade guide assembly.

The other blade guide assembly is mounted on the idle side of the saw head. It is referred to as the "outer" assembly and is adjustable for various widths of materials to be processed.

Blade guide alignment includes four steps:

- Blade Deflection
- Blade Guide Vertical Tilt
- Blade Guide Flange Spacing
- Blade Guide Horizontal Tilt

Perform the blade guide alignment after you have aligned the blade on the wheels and adjusted the blade and blade guide arm parallel to the bed rails. After blade guide alignment, check the scale indicator to make sure it is adjusted properly.

6.7 Blade Deflection

Perform the following steps to achieve proper blade deflection with the blade guides.

1. Raise the carriage until the blade is 15" (375 mm) above a bed rail. Measure the actual distance with a tape from the top of the rail to the bottom of the blade.

See Figure 6-10.

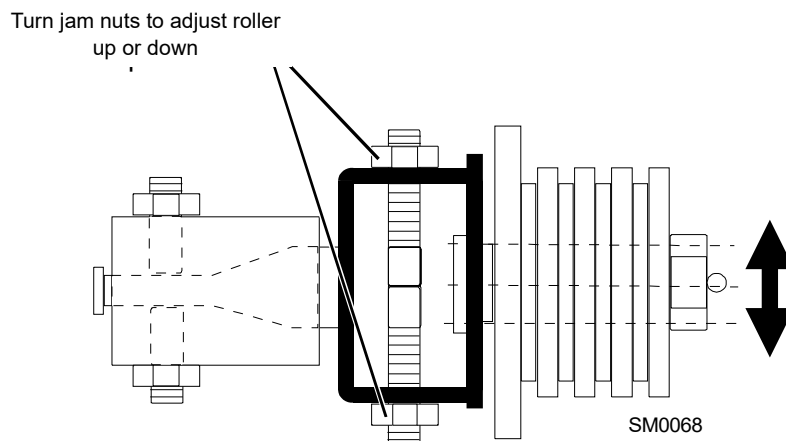


FIG. 6-10

2. Loosen the bottom jam nut and tighten the top jam nut until the blade guide deflects the blade down 1/4" (6 mm).
3. Repeat for the other blade guide.

NOTE: Be sure that the blade guard clears the blade on both guide assemblies. The guard on the outer guide assembly should be checked with the arm all the way in and all the way out.

6.8 Blade Guide Vertical Tilt Adjustment

Check that the blade guide does not tilt the blade up or down. A Blade Guide Alignment Tool (BGAT) is provided to help you measure the vertical tilt of the blade.

1. Open the adjustable blade guide arm 1/2" (15 mm) from full open.
2. Clamp the alignment tool on the blade. Position the tool close to a blade guide roller. Be sure the tool does not rest on a tooth or burr, and is lying flat on the blade.

See Figure 6-11.

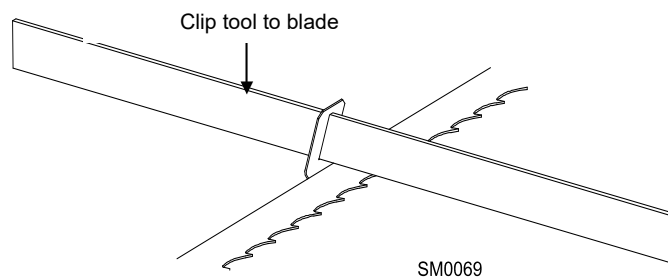


FIG. 6-11

3. Measure the distance from the bed rail to the bottom of the tool.
4. Move the carriage so that the front end of the tool is positioned above the bed rail.
5. Measure the distance from the bed rail to the bottom edge of the tool.
6. Loosen one set screw at the side of the blade guide assembly.
7. Use the set screws shown to tilt the blade guide until the measurement from the bed rail to the tool equals the first measurement taken at the center of the tool.

See Figure 6-12.

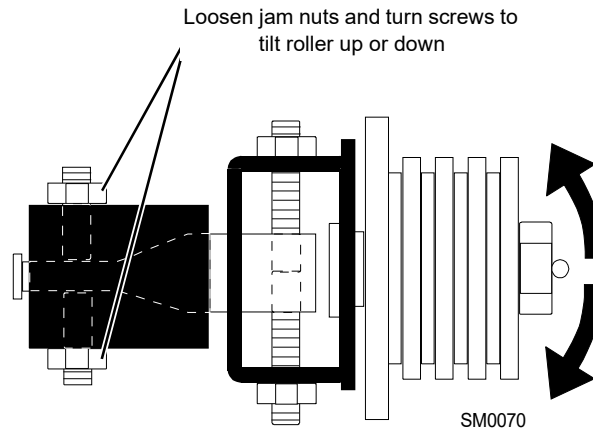


FIG. 6-12

8. Move the carriage forward so the back end of the tool is over the bed rail.
9. Use the set screws shown to adjust the blade guide tilt until the measurement from the bed rail to the tool equals the other two measurements taken.
10. Move the tool close to the other blade guide and repeat the previous steps.

NOTE: If major adjustments to blade guide tilt were made, remeasure the distance between the blade and the bed rails to ensure the correct 1/4" (6.5 mm) blade guide deflection. Adjust if necessary.

6.9 Blade Guide Spacing

HINT: When adjusting blade guide spacing, loosen the top set screw and one side set screw only. This will insure horizontal and vertical tilt adjustments are maintained when the set screws are retightened.

1. Adjust the inner blade guide so the blade guide flange is approximately 1/16" - 1/8" (1.5 - 3.0 mm) from the back of the blade.
2. Loosen one side and one top set screw shown. Tap the blade guide forward or backward until properly positioned.

See Figure 6-13.

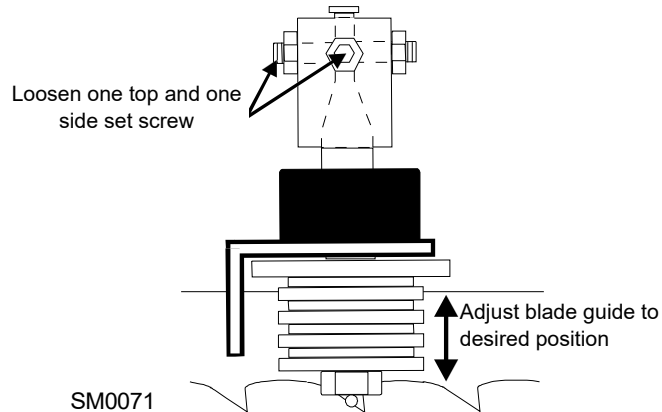


FIG. 6-13

3. Retighten the two set screws.
4. Adjust the outer blade guide in the same way so the blade guide flange is approximately 1/16" - 1/8" (1.5 - 3.0 mm) from the back of the blade.

6.10 Horizontal Tilt Adjustment

1. Finally, both blade guides must be tilted horizontally. Adjust the blade guide arm half way in.

See Figure 6-14.

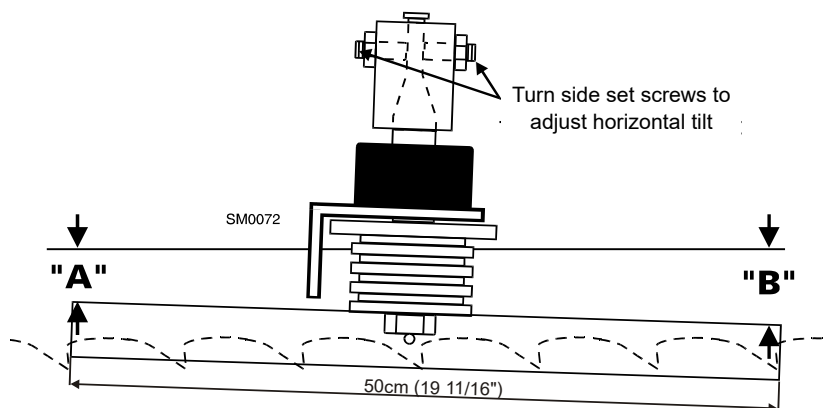


FIG. 6-14

2. Place Blade Guide Alignment Tool against the face of the outer blade guide roller.
3. Center the tool on the roller and measure between the back edge of the blade and the ruler at the end closest to the inner blade guide ("B").
4. Measure between the back edge of the blade and the other end of the ruler ("A").

5. The roller should be parallel to the blade ($A=B$) or tilted slightly to the left ($A=B-1/4"$ [6 mm]).
6. Use the side set screws to adjust the horizontal tilt of the roller.
7. Repeat Steps 3 - 7 for the inner blade guide roller.

NOTE: Once the blade guides have been adjusted, any cutting variances are most likely caused by the blade. **See Blade Handbook, Form #600.**

6.11 Side Supports

Logs and boards are clamped against the side supports when sawing. The sides supports must be square to the bed to ensure square lumber.

1. Place a flat board across the bed rails.

See Figure 6-15.

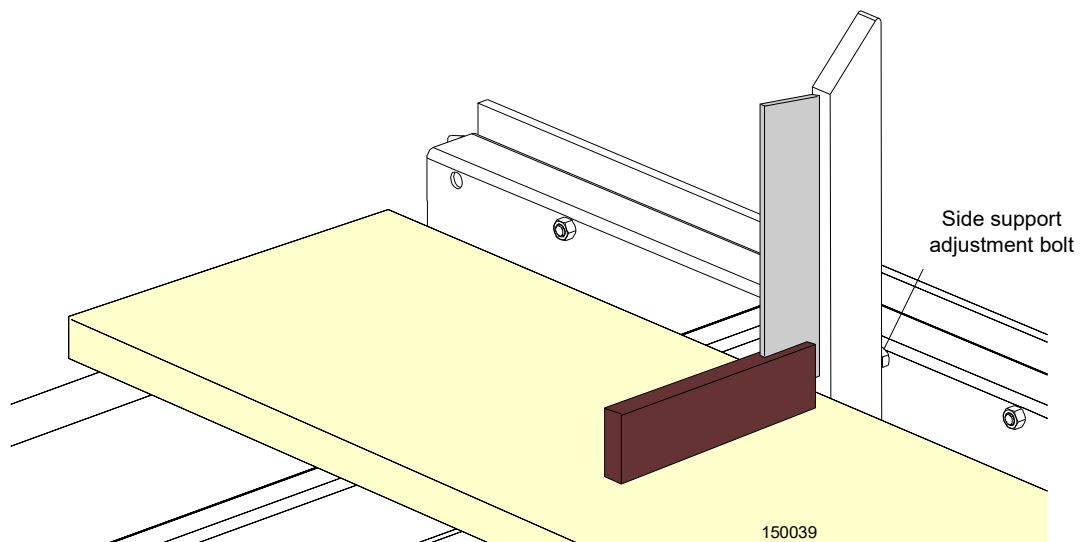


FIG. 6-15

2. Swing a side support up so that it is vertical.
3. Pull back at the top of the support to eliminate slack as if a log were being clamped against it.
4. Check the angle of each support with a square on the board.
5. The side support should be 90° to the bed rails. Turn the adjustment bolt counterclockwise to tilt the top of the side support forward.
6. Repeat for the remaining side supports.

6.12 Blade Height Scale Adjustment

After the entire sawmill has been aligned and all adjustments made, check that the blade height scale indicates the true distance from the blade to the bed rails.

1. Move the saw head so the blade is positioned directly above one of the bed rails. Measure from the bottom edge on a down-set tooth of the blade to the top of the bed rail (or stainless steel sleeve if applicable).

See Figure 6-16.

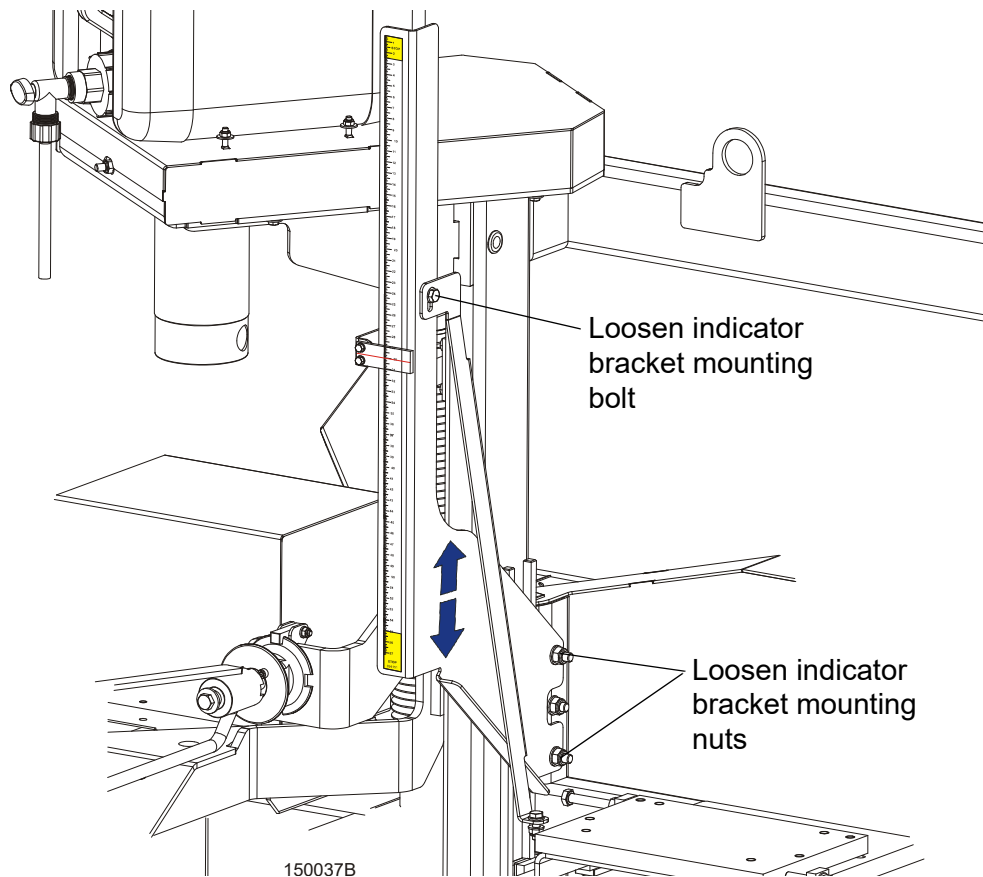


FIG. 6-16

2. Loosen the indicator bracket mounting bolt and nuts, adjust the bracket until the indicator is aligned with the correct mark on the scale. Retighten the bracket mounting bolt and nuts.

For example, if the measurement from blade to bed rail was 14 3/4" (375 mm), make sure the indicator reads 14 3/4" (375 mm) on the scale.

6.13 Track Roller Distance Adjustment

Using the screw (1), adjust the distance between the track roller (2) and the track rail (3) so that the mast can move freely (see the figure below). The distance should be about 0.5 mm.

See Figure 6-17.

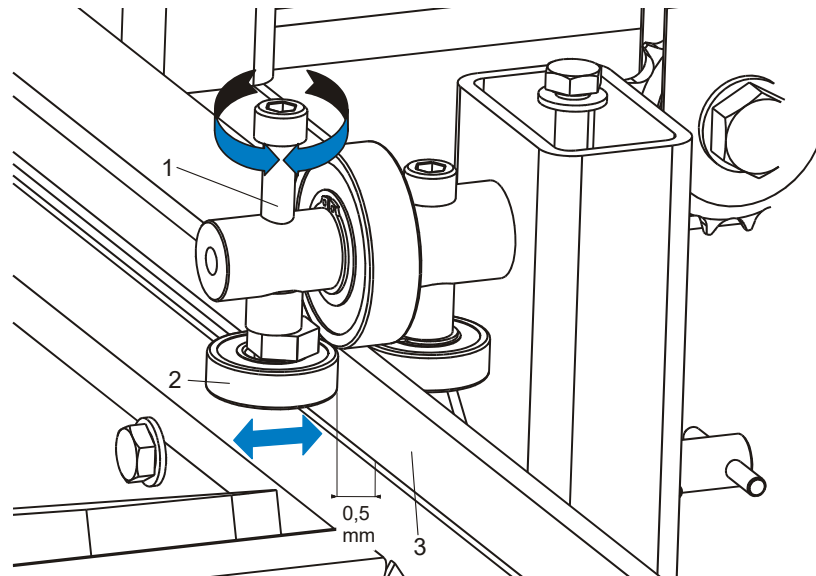


FIG. 6-17

6.14 Setting bottom bracket

See **Figure 6-18**. The bottom bracket prevents the belt from resonating when disengaging the blade drive wheel. For correct adjustment, set the bracket so that after loosening the drive belt, the bracket pin rests on the belt. The belt should be loose and it should not touch the engine pulley.

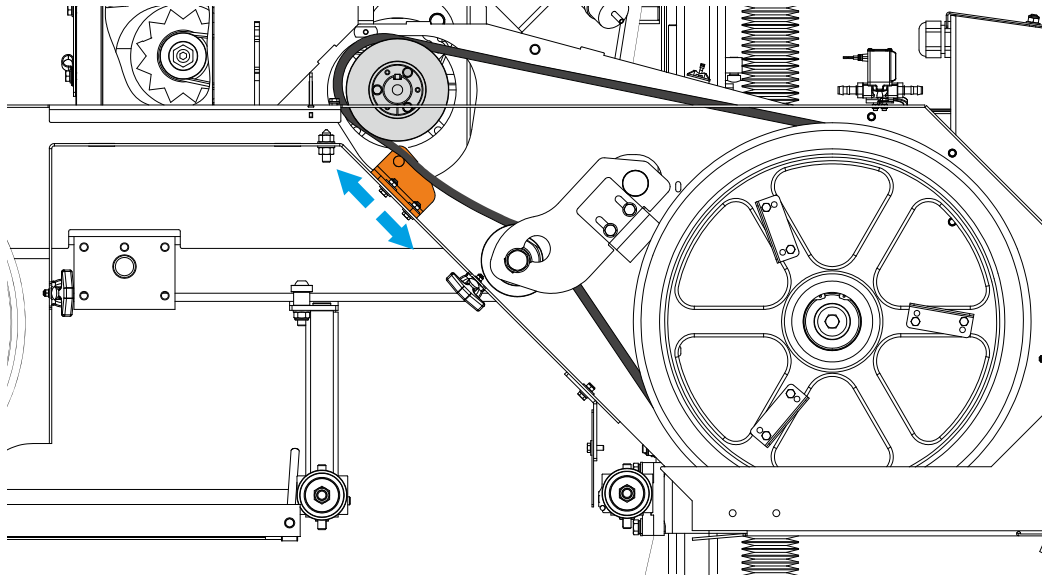


FIG. 6-18

EC declaration of conformity
according to EC Machinery Directive 2006/42/EC, Annex II, 1.A

Manufacturer:

Wood-Mizer Industries sp. z o.o.
Nagórna 114, 62-600 Koło; Poland
Tel. +48 63 26 26 000

This declaration of conformity is issued under the sole responsibility of the manufacturer.

Following machine in our delivered version complies with the appropriate essential safety and health requirements of the EC Machinery Directive 2006/42/EC based on its design and type, as brought into circulation by us. In case of alteration of the machine, not agreed by us, this declaration is no longer valid.

We, the undersigned herewith declare, that:

Designation of the machine: **SAWMILL**
Model: LT15
TYPE:
Serial Number:
VIN Number:

**Is in conformity with the following
EC directives:**

EC Machinery Directive 2006/42/EC
EC Electromagnetic Compatibility Directive
2014/30/EU

**And is in conformity with the following
Harmonized Standards:**

PN-EN 1807-2:2013-08
PN-EN ISO 13849-1:2016-02
PN-EN 60204-1:2018-12

Notified Body according to annex IV: Sieć Badawcza Łukasiewicz
INSTYTUT TECHNOLOGII DREWNA
Centrum Weryfikacji Wyrobów Przemysłu Drzewnego
ul. Winiarska 1, 60-654 Poznań

Notification No.: 1583

EC type-examination certificate no. 0719/2019

Responsible for Technical Documentation: Piotr Adamiec / Engineering Manager
Wood-Mizer Industries Sp. z o.o.
62-600 Koło, Nagórna 114, Poland
Tel. +48 63 26 26 000

Place/Date/Authorized Signature: Koło, 19.09.2019 

Title: Engineering Manager