

Wood-Mizer[®] Sawmill

Replacement Parts Manual

LT15 S3 E11
LT15 M2 E11

rev. C1.00
rev. C1.00



Safety is our #1 concern! Read and understand all safety information and instructions before operating, setting up or maintaining this machine.

July 2005

Form #797

SECTION 1	GENERAL INFORMATION	1-1
1.1	How To Use The Parts List	1-1
1.2	Sample Assembly	1-1
SECTION 2	BED FRAME	2-1
2.1	Log Side Support Assembly	2-1
2.2	Bed Section Connecting Hardware	2-2
2.3	Outrigger Leg Kit	2-3
2.4	Outrigger Leg Kit (Optional).....	2-4
2.5	Log Clamp Assembly	2-5
2.6	Auxiliary Bed Rail Assembly	2-6
2.7	Log Wedge, Loading Ramps & Cant Hook (Optional).....	2-7
2.8	Bed Extension.....	2-8
2.9	”M” Type Frame Bed Section	2-9
2.10	”S” Type Frame Bed Section	2-10
SECTION 3	BLADE GUIDE ROLLERS & ARM	3-1
3.1	Blade Guide Assembly, Idle Side.....	3-1
3.2	Blade Guide Assembly, Drive Side.....	3-3
3.3	Blade Guide Roller Guard	3-5
3.4	Blade Guide Arm Assembly	3-6
SECTION 4	BLADE WHEELS & TENSIONER	4-1
4.1	Blade Wheel Assembly, Drive Side	4-1
4.2	Blade Wheel Assembly, Idle Side	4-2
4.3	Blade Tensioner Assembly.....	4-3
4.4	Motor Assembly	4-4
4.5	Power Cord Bracket	4-5
SECTION 5	SAW HEAD	5-1
5.1	Blade Housing Cover	5-1
5.2	Water Lube Assembly	5-3
5.3	Saw Head Decals.....	5-4
5.4	Control Box	5-6
5.5	Electric Box.....	5-8
SECTION 6	FEED SYSTEM	6-1
6.1	Feed Crank Assembly.....	6-1
6.2	Track Rail, Rollers & Travel Pins	6-3
6.3	Feed Rope, V-groove Rollers & Brackets.....	6-5
SECTION 7	UP/DOWN SYSTEM	7-1
7.1	AC Up/Down Drive Assembly.....	7-1
7.2	Slide Pads & Blade Height Scale Indicator.....	7-4
7.3	Blade Height Scale & Up/Down Limit Switches.....	7-6
7.4	Blade Height Scale (Optional).....	7-8

SECTION 1 GENERAL INFORMATION

1.1 How To Use The Parts List

- Use the index above to locate the assembly that contains the part you need.
- Go to the appropriate section and locate the part in the illustration.
- Use the number pointing to the part to locate the correct part number and description in the table.
- Parts shown indented under another part are included with that part.
- Parts marked with a diamond (◆) are only available in the assembly listed above the part.

See the sample table below. Sample Part #A01111 includes part F02222-2 and subassembly A03333. Subassembly A03333 includes part S04444-4 and subassembly K05555. The diamond (◆) indicates that S04444-4 is not available except in subassembly A03333. Subassembly K05555 includes parts M06666 and F07777-77. The diamond (◆) indicates M06666 is not available except in subassembly K05555.

1.2 Sample Assembly				
REF	DESCRIPTION (◆ Indicates Parts Available In Assemblies Only)	PART #	QTY.	
	Sample Assembly, Complete (Includes All Indented Parts Below)	A01111	1	
1	Sample Part	F02222-22	1	
	Sample Subassembly (Includes All Indented Parts Below)	A03333	1	
2	Sample Part (◆ Indicates Part Is Only Available With A03333)	S04444-4	1	◆
	Sample Subassembly (Includes All Indented Parts Below)	K05555	1	
3	Sample Part (◆ Indicates Part Is Only Available With K05555)	M06666	2	◆
4	Sample Part	F07777-77	1	

To Order Parts:

- From Europe call our European Headquarters and Manufacturing Facility in Kolo, Poland at **+48-63-2626000**. From the continental U.S., call our toll-free Parts hotline at **1-800-448-7881**. Have your customer number, vehicle identification number, and part numbers ready when you call.
- From other international locations, contact the Wood-Mizer distributor in your area for parts.



General Information

Sample Assembly

SECTION 2 BED FRAME

2.1 Log Side Support Assembly

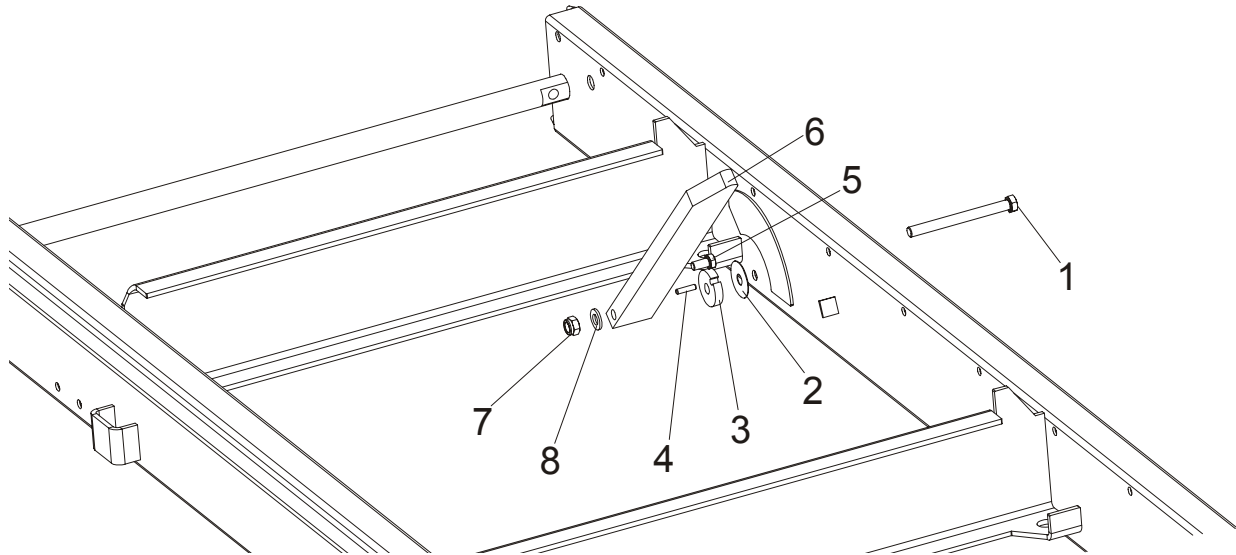

REF	DESCRIPTION (◆ Indicates Parts Available In Assemblies Only)	PART #	QTY.
1	BOLT, M12X130-8.8 HEX HEAD ZINC	F81004-36	1
2	WASHER, 33/64 X 1 3/4 X 1/32" NYLON	014972	1
3	WASHER, LT15 THICK SPACER	085981-1	1
4	PIN, 6N6X25 60HRC PARALLEL	085983	1
5	BOLT, M10 X 20-5.8 HEX HEAD FULL THREAD ZINC	F81003-1	1
6	SUPPORT, LT15 LOG SIDE COMPLETE PAINTED	085982-1	1
7	NUT, M12-8 HEX NYLON ZINC LOCK	F81034-2	1
8	WASHER, 13 FLAT ZINC	F81056-1	1

2.2 Bed Section Connecting Hardware

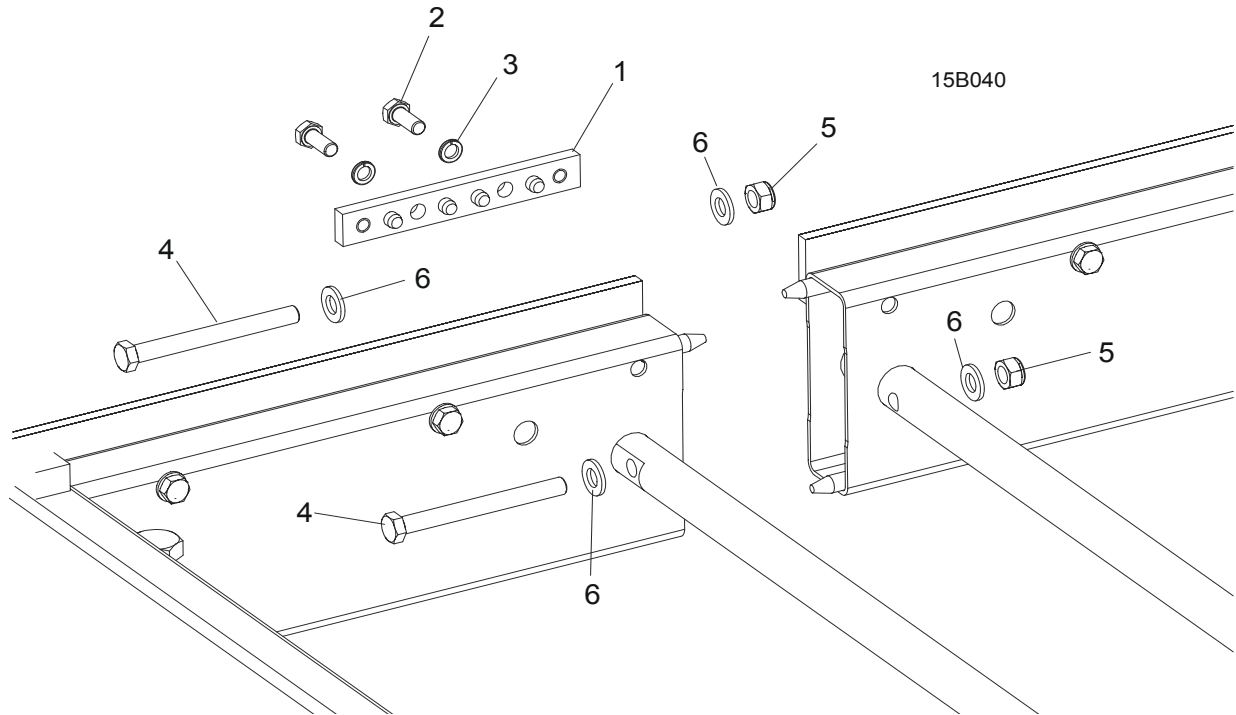

REF	DESCRIPTION (◆ Indicates Parts Available In Assemblies Only)	PART #	QTY.
1	SPLICE, TRACK RAIL PINNED	086659-1	1
2	BOLT, M10 X 25-8.8 HEX HEAD FULL THREAD ZINC	F81003-11	2
3	WASHER, 10.2 SPLIT LOCK ZINC	F81055-2	2
4	BOLT, M12X120 8.8 HEX HEAD ZINC	F81004-38	2
5	NUT, M12-8 HEX NYLON ZINC LOCK	F81034-2	2
6	WASHER, 13 FLAT ZINC	F81056-1	4

2.3 Outrigger Leg Kit

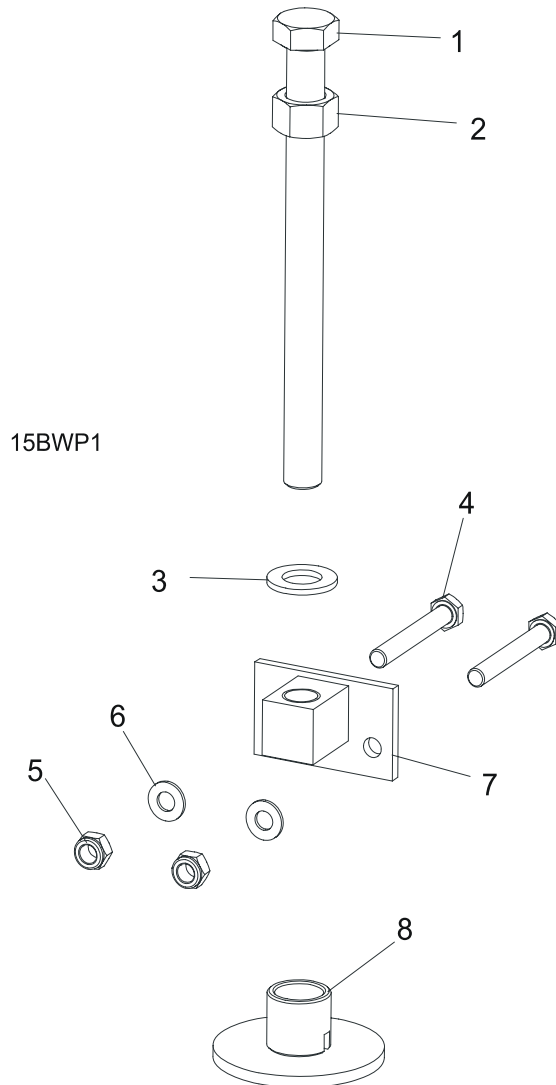

REF	DESCRIPTION (◆ Indicates Parts Available In Assemblies Only)	PART #	QTY.
	OUTRIGGER LEG KIT FOR 1950 MM BED SECTION (LT15S3)	095232 ¹	3
	OUTRIGGER LEG KIT FOR 2700 MM BED SECTION (LT15M2)	095234 ²	2
1	Bolt, M20x240-8.8 Hex Head Full Thread Zinc	F81007-1	1
2	Nut, M20-8 Hex Zinc	F81037-1	1
3	Washer, 21 Flat Zinc	F81059-2	1
4	Bolt, M10x75-8.8 Hex Head Zinc	F81003-15	2
5	Nut, M10-8-B Hex Nylon Zinc Lock	F81033-1	2
6	Washer, 10.5 Flat Zinc	F81055-1	2
7	Bracket Weldment, LT15 Leg Mount	085986-1	1
8	Plate Weldment, LT15 Leg Foot Zinc-plated	086723-1	1

¹ Four legs are mounted to each 1950-mm long bed section.

² Six legs are mounted to each 2700-mm long bed section.

2.4 Outrigger Leg Kit (Optional)

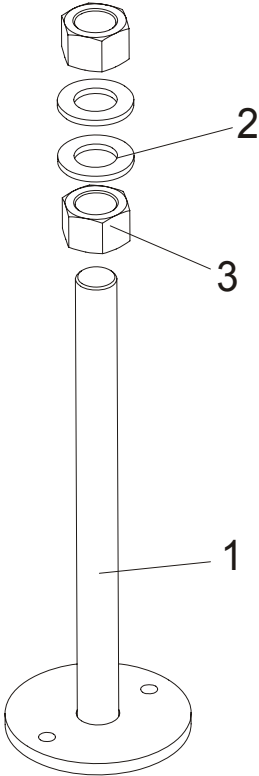

REF	DESCRIPTION (◆ Indicates Parts Available In Assemblies Only)	PART #	QTY.
	OUTRIGGER LEG KIT FOR 1950 MM BED SECTION (LT15S3)	095231 ¹	3
	OUTRIGGER LEG KIT FOR 2700 MM BED SECTION (LT15M2)	095233 ²	2
1	Outrigger Weldment, LT15 Zinc-plated	094513-1	1
2	Washer, 21 Flat Zinc	F81059-2	2
3	Nut, M20-8 Hex Zinc	F81037-1	2

¹ Four legs are mounted to each 1950-mm long bed section.

² Six legs are mounted to each 2700-mm long bed section.

2.5 Log Clamp Assembly

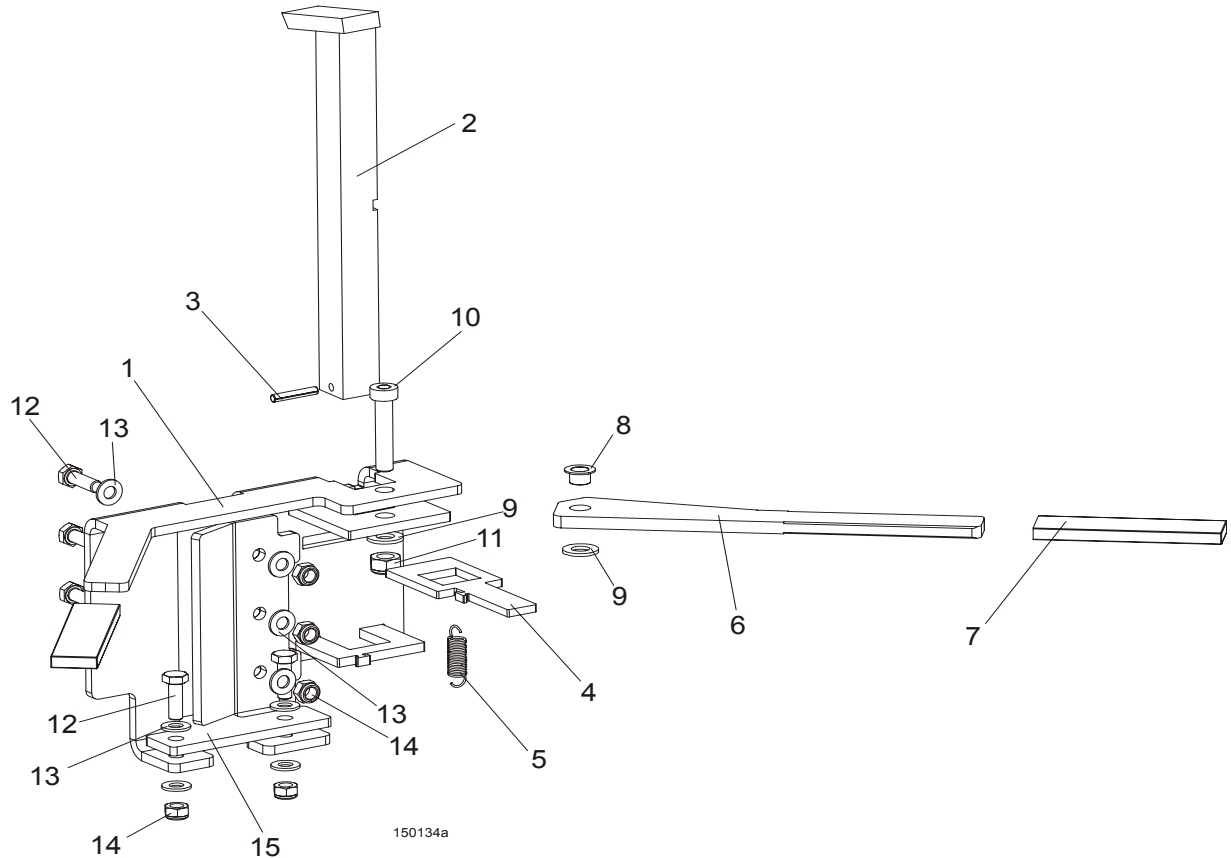

REF	DESCRIPTION (◆ Indicates Parts Available In Assemblies Only)	PART #	QTY.
	LT15 LOG CLAMP ASSEMBLY	094530	2
1	Clamp Weldment, LT15 Zinc-plated	094527-1	1
2	Arm Weldment, Log Clamp Zinc-plated	094534-1	1
3	Pin, 5x30 Roll Zinc-plated	F81044-21	1
4	Plate, Log Clamp Lock Zinc-plated	094529-1	1
5	Spring, 1.6x12x38 Extension	092208	1
6	Cam, LT15 Log Clamp Zinc-plated	095983-1	1
7	Grip, LT15 Log Clamp Handle	086875	1
8	Bushing, XFM-1012-09	093822	1
9	Washer, 10.5 Flat Zinc	F81055-1	2
10	Bolt, 10/M8X25 12.9 ISO7379 Shoulder	F81003-77	1
11	Nut, M8-8-B Hex Nylon Zinc Lock	F81032-2	1
12	Bolt, M8x25-8.8-B Hex Head Full Thread Zinc	F81002-5	7
13	Washer, 8.4 Flat Zinc	F81054-1	10
14	Nut, M8-8-B Hex Nylon Zinc Lock	F81032-2	5
15	Plate, Log Clamp Lower Zinc-plated	094525-1	1

2.6 Auxiliary Bed Rail Assembly

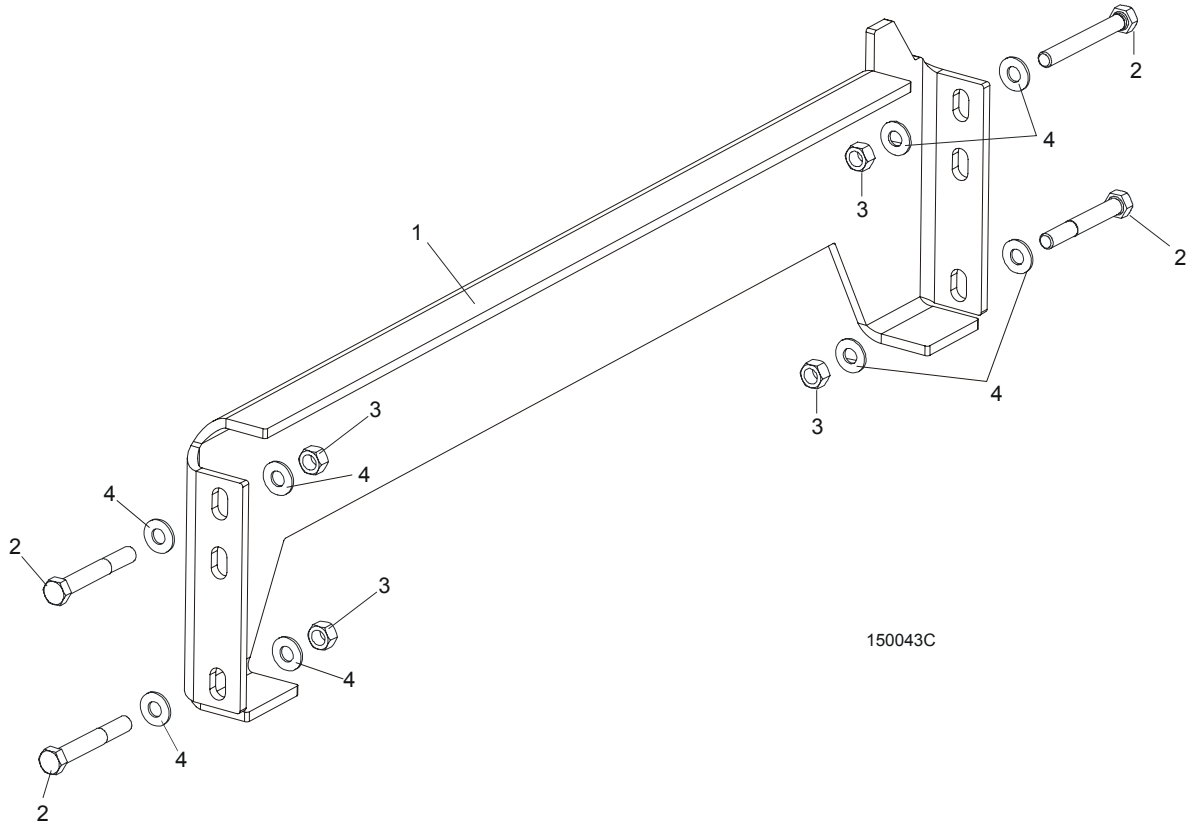

REF	DESCRIPTION (◆ Indicates Parts Available In Assemblies Only)	PART #	QTY.	
1	RAIL WELDMENT, LT15 AUXILIARY BED	095490-1	1	◆
2	BOLT M10X75-8.8 HEX HEAD ZINC	F81003-15	4	
3	NUT, M10-8-B HEX NYLON ZINC LOCK	F81033-1	4	
4	WASHER 10,5 ZINC FLAT	F81055-1	8	

2.7 Log Wedge, Loading Ramps & Cant Hook (Optional)

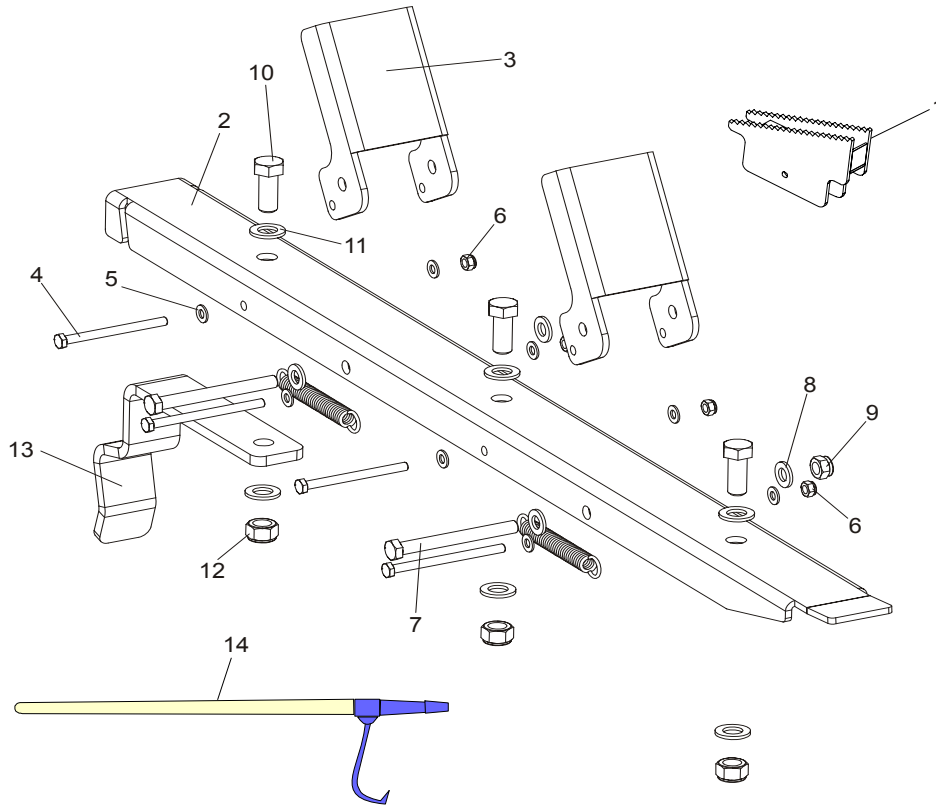

REF	DESCRIPTION (◆ Indicates Parts Available In Assemblies Only)	PART #	QTY.
	ACCESSORIES, LT15 SAWMILLS	085997	1
1	Wedge Weldment, Log Taper (included in 015811 kit)	086035-1	1
	Ramp Assembly, Log Loading, LT15 compl.	097977	2
	Ramp Assembly	097483	1
2	Ramp Weldment, zink plated	097481-1	1
3	Bracket, Log Loading Stop, zink plated	097482-1	2
4	Bolt M8x100 -8.8	F81002-23	4
5	Washer, M8, Flat, zinc	F81054-1	8
6	Nut, M8, Hexagon, Nylon lock, zinc	F81032-2	4
7	Bolt, M12x115-8.8-Fe/Zn5 PN-M/82101	F81004-33	2
8	Washer, M12 , Flat, Zinc	F81056-1	2
9	Nut, M12, Hexagon, Nylon, zinc,lock	F81034-2	2
10	Bolt, M16x40-8.8 Fe/Zn5	F81006-13	2
11	Washer, M16, Flat, zinc	F81058-1	4
12	Nut, M16, hex, nylon zinc lock	F81036-2	2
13	Bracket, LT15 Ramp, zinc	097976-1	1
14	Cant Hook (included in 015811 kit)	CH	1

2.8 Bed Extension

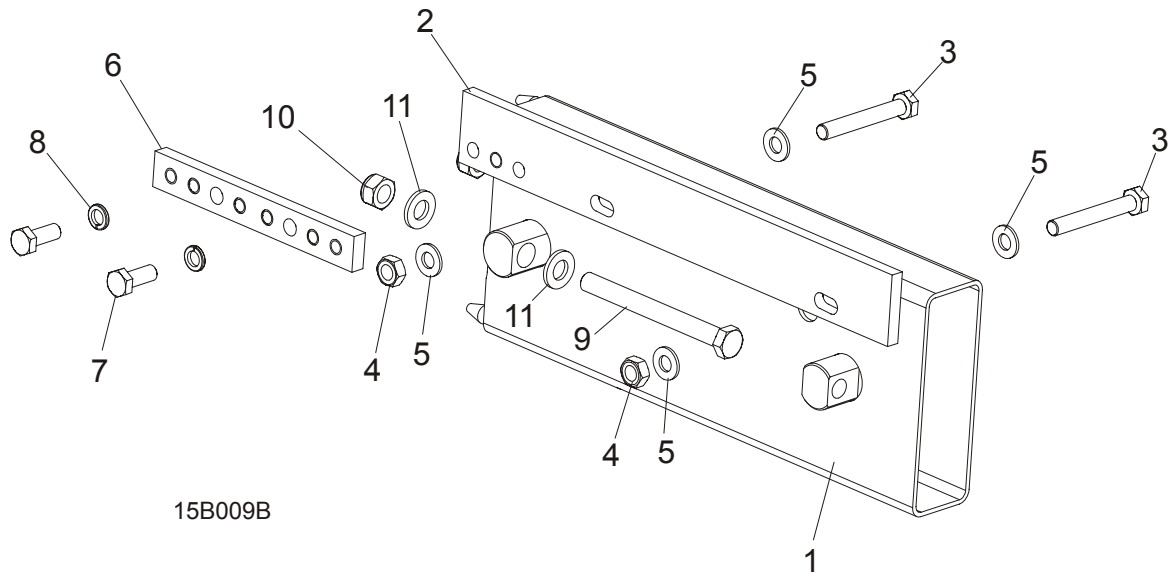

REF	DESCRIPTION (◆ Indicates Parts Available In Assemblies Only)	PART #	QTY.	
	EXTENSION, BED COMPLETE	094251	1	
1	Tube, LT15 GP Bed Extension	094249-1	1	
2	Rail, Bed Extension Track Zinc-plated	094250-1	1	
3	Bolt, M10 x 75-8.8 Hex Head Zinc	F81003-15	2	
4	Nut, M10-8-B Hex Nylon Zinc Lock	F81033-1	2	
5	Washer, 10.5 Flat Zinc	F81055-1	4	
6	Splice, Track Rail Pinned	086659-1	1	
7	Bolt, M10 x 25-8.8 Hex Head Full Thread Zinc	F81003-11	2	
8	Washer, 10.2 Split Lock Zinc	F81055-2	2	
9	Bolt, M12 x 120-8.8 Hex Head Zinc	F81004-38	2	
10	Nut, M12-8 Hex Nylon Zinc Lock	F81034-2	2	
11	Washer, 13 Flat Zinc	F81056-1	4	

2 **BED FRAME**
"M" Type Frame Bed Section

2.9 "M" Type Frame Bed Section

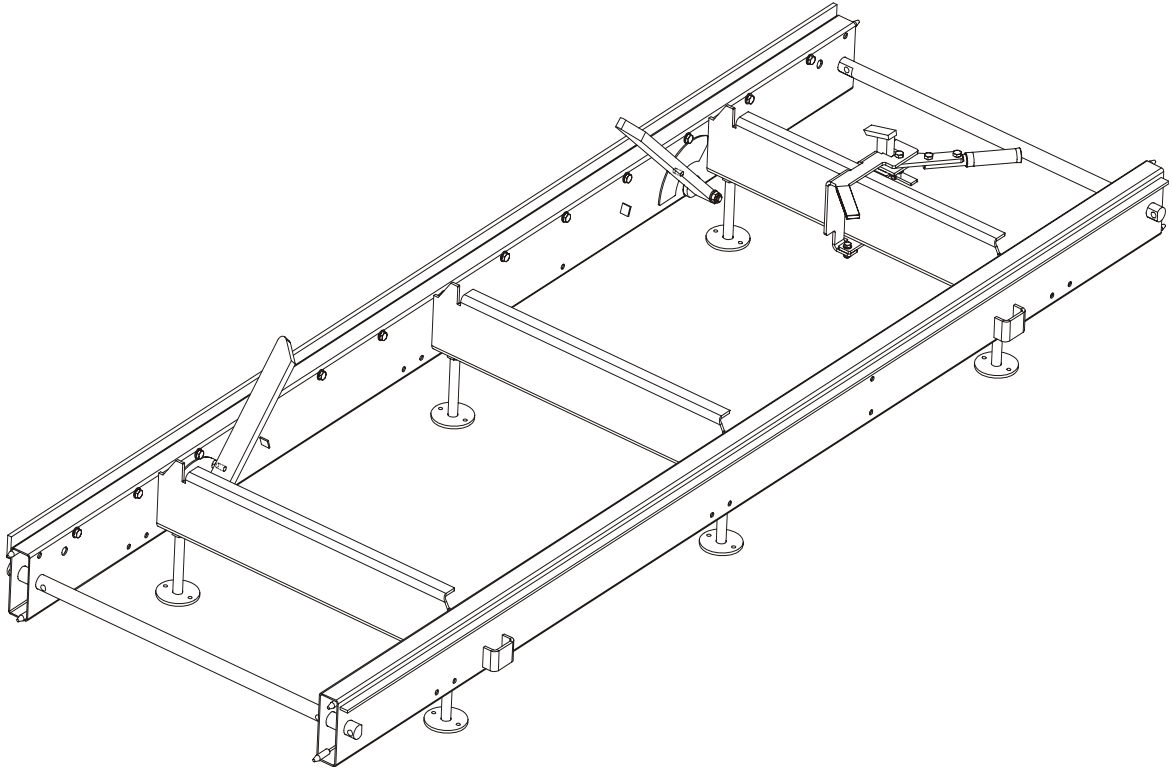

REF	DESCRIPTION (◆ Indicates Parts Available In Assemblies Only)	PART #	QTY.	
	LT15 BED SECTION ASSEMBLY - LONG	094697		

2.10 "S" Type Frame Bed Section

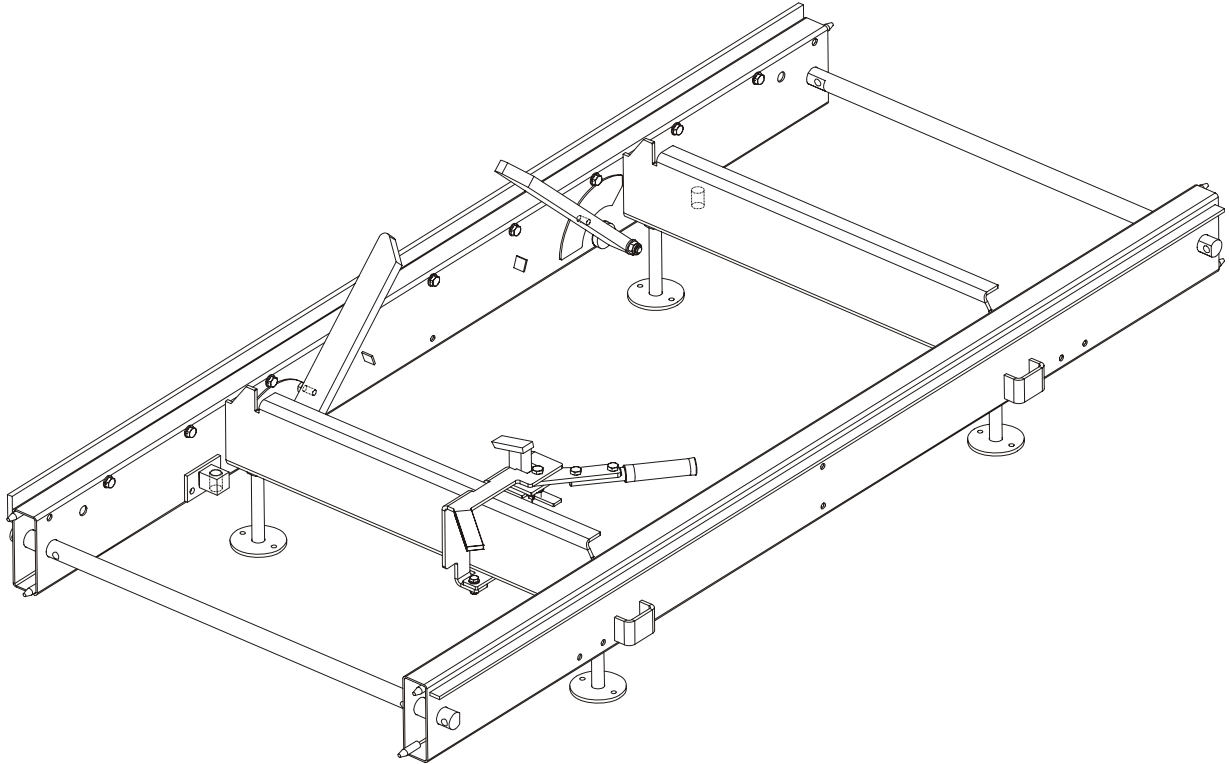

REF	DESCRIPTION (◆ Indicates Parts Available In Assemblies Only)	PART #	QTY.	
	LT15 BED SECTION ASSEMBLY - SHORT	094514		

SECTION 3 BLADE GUIDE ROLLERS & ARM

3.1 Blade Guide Assembly, Idle Side

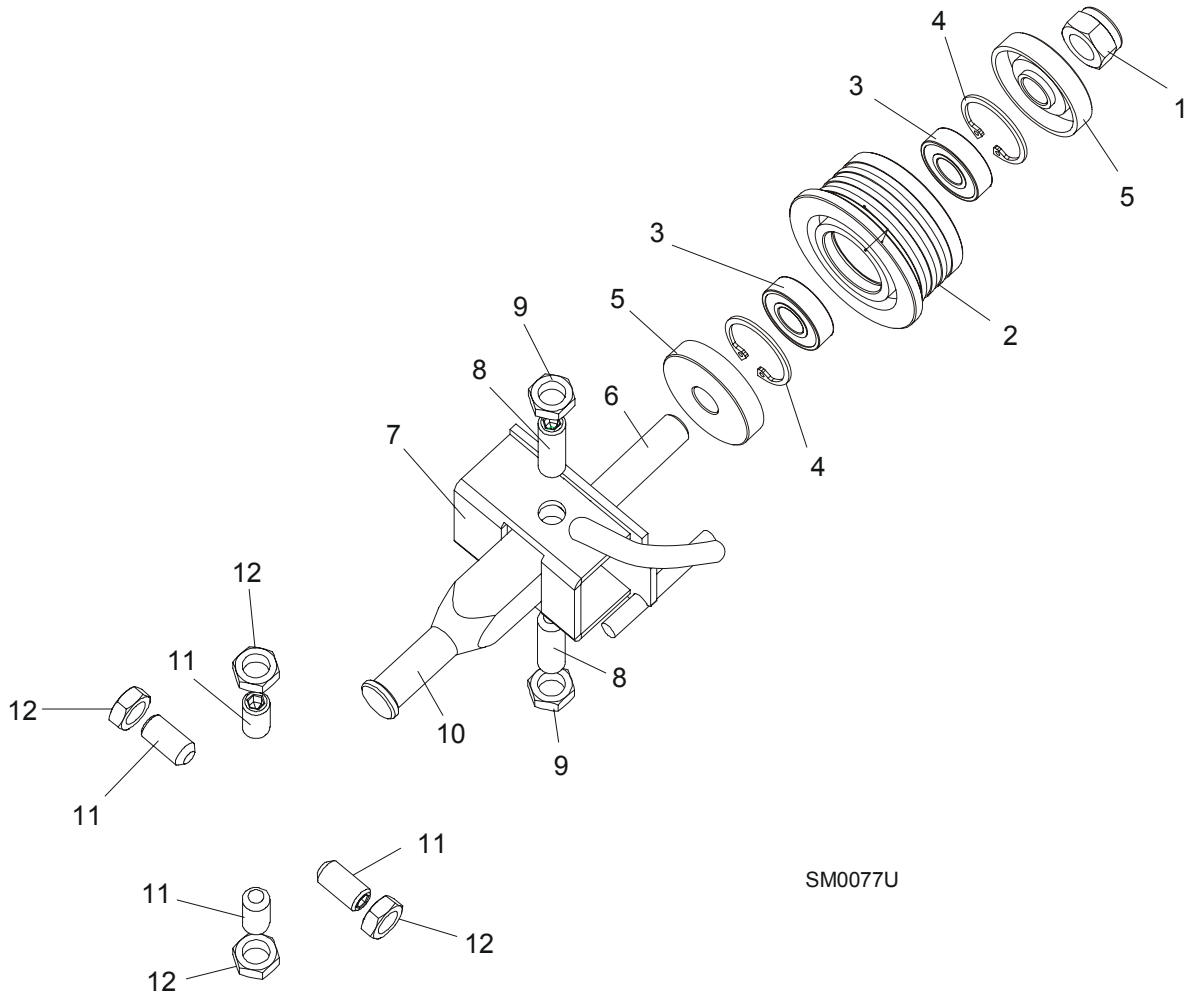

REF	DESCRIPTION (◆ Indicates Parts Available In Assemblies Only)	PART #	QTY.	
	BLADE GUIDE ASSEMBLY, IDLE SIDE	094683	1	
	Roller, Blade Guide Complete Standard	087887	1	
1	Nut, M12-8 Hex Nylon Zinc Lock	F81034-2	1	
2	Roller, Blade Guide Narrow	087889	1	◆
3	Bearing, 6001 2RSR FAG	087893	2	
4	Ring, W28 Inside Retaining	F81090-9	1	
5	Washer, Zinc-plated Spacer	087891-1	2	
6	Shaft, Blade Guide Roller Zinc-plated	087763-1	1	
7	Bracket Weldment, Idle Side Blade Guide Painted	094681-1	1	
8	Screw, M10x1x40 DIN 913 A2-70 Set Stainless Steel	F81015-2	2	

BLADE GUIDE ROLLERS & ARM

Blade Guide Assembly, Idle Side

3

9	Nut, M10x1-04-ST-A2 ISO 8675 Thin	F81033-10	2	
10	Shaft, Zinc-plated Blade Guide Mount	088255-1	1	
11	SCREW, M10X1X20 DIN 913 SET STAINLESS STEEL	F81015-1	4	
12	NUT, M10x1-04-ST-A2 ISO 8675 THIN	F81033-10	4	

3.2 Blade Guide Assembly, Drive Side

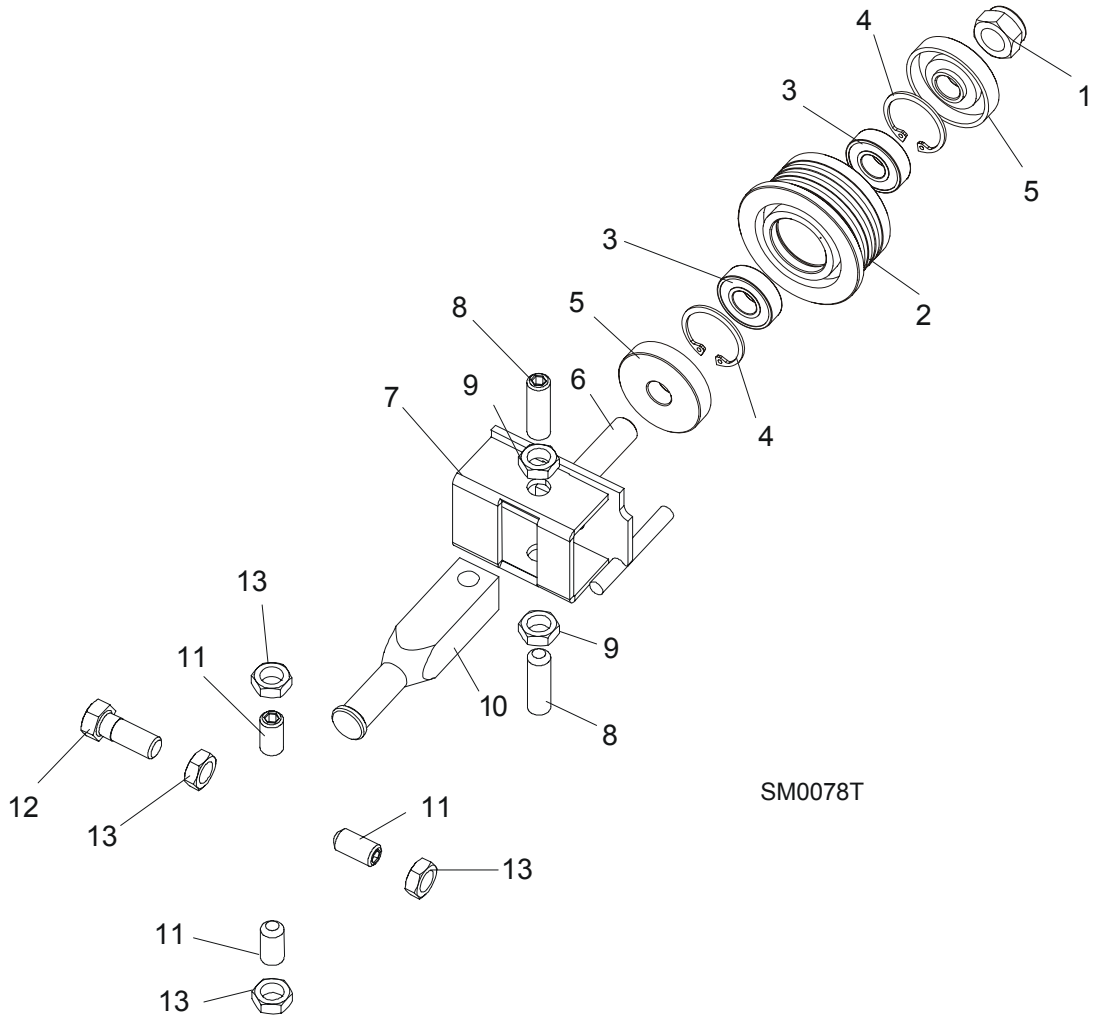

REF	DESCRIPTION (◆ Indicates Parts Available In Assemblies Only)	PART #	QTY.	
	BLADE GUIDE ASSEMBLY, DRIVE SIDE	094682	1	
	Roller, Blade Guide Complete Standard	087887	1	
1	Nut, M12-8 Hex Nylon Zinc Lock	F81034-2	1	
2	Roller, Blade Guide Narrow	087889	1	◆
3	Bearing, 6001 2RSR FAG	087893	2	
4	Ring, W28 Inside Retaining	F81090-9	1	
5	Washer, Zinc-plated Spacer	087891-1	2	
6	Shaft, Blade Guide Roller Zinc-plated	087763-1	1	
7	Bracket Weldment, Blade Guide Painted	094679-1	1	
	Screw Kit, Blade Guide Adjustment w/Nuts (for two blade guide assemblies)	K09942	1	
8	Screw, M10x1x40 DIN 913 A2-70 Set Stainless Steel	F81015-2	2	
9	Nut, M10x1-04-ST-A2 ISO 8675 Thin	F81033-10	2	

BLADE GUIDE ROLLERS & ARM

Blade Guide Assembly, Drive Side

3

10	Shaft, Zinc-plated Blade Guide Mount	088255-1	1	
11	SCREW, M10X1X20 DIN 913 SET STAINLESS STEEL	F81015-1	3	
12	BOLT, M10X1X25 DIN 933 STAINLESS STEEL	F81003-28	1	
13	NUT, M10x1-04-ST-A2 ISO 8675 THIN	F81033-10	4	

3.3 Blade Guide Roller Guard

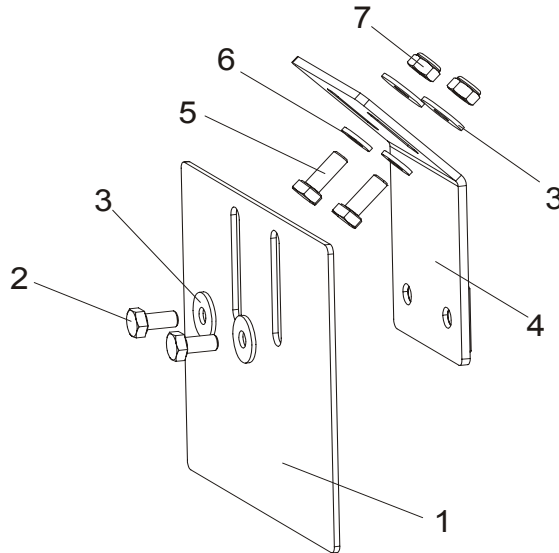

REF	DESCRIPTION (◆ Indicates Parts Available In Assemblies Only)	PART #	QTY.
1	GUARD, BLADE GUIDE ROLLER PAINTED	092379-1	1
2	BOLT, M6X12-8.8 HEX HEAD FULL THREAD ZINC	F81001-7	2
3	WASHER, 6.5 SPECIAL FLAT ZINC	F81053-11	4
4	BRACKET, ROLLER GUARD MOUNT PAINTED	092378-1	1
5	BOLT, M6X16 8.8 HEX HEAD FULL THREAD ZINC	F81001-15	2
6	WASHER, 6.4 FLAT ZINC	F81053-1	2
7	NUT, M6-8-B HEX NYLON ZINC LOCK	F81031-2	2

3.4 Blade Guide Arm Assembly

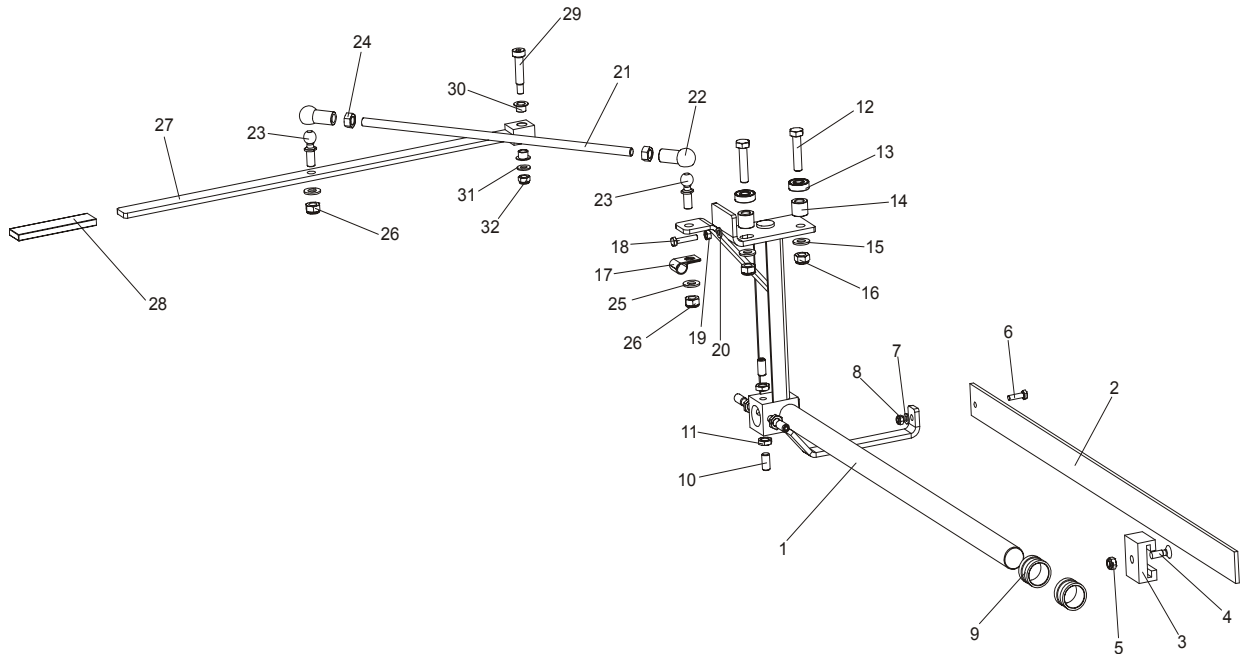

REF	DESCRIPTION (◆ Indicates Parts Available In Assemblies Only)	PART #	QTY.
	BLADE GUIDE ARM W/LEVER - COMPLETE	094136	1
1	Arm Weldment, LT15 Blade Guide	086662	1
2	Bar, LT15 Blade Guard	088306	1
3	Guide, Blade Guard	088305	1
4	Screw, M8x25 Cross Recessed Countersunk Head Zinc	F81002-51	1
5	Nut, M8-8-B Hex Nylon Zinc Lock	F81032-2	1
6	Bolt, M6x20-8.8 Hex Head Full Thread Zinc	F81001-2	1
7	Washer, 6.4 Flat Zinc	F81053-1	1
8	Nut, M6-8-B Hex Nylon Zinc Lock	F81031-2	1
9	Bushing, LT15 Blade Guide	086684	1
10	Screw, M10x1x20 DIN913 Set Stainless Steel	F81015-1	4
11	Nut, M10x1-04-ST-A2 ISO 8675 Thin	F81033-10	4
12	Bolt, M10x45-8.8 Hex Head Full Thread Zinc	F81003-3	2
13	Bearing, 6000.2RSR FAG	087471	2
14	Bushing, Zinc-plated Spacer	094255-1	2
15	Washer, 10.5 Flat Zinc	F81055-1	2
16	Nut, M10-8-B Hex Nylon Zinc Lock	F81033-1	2
17	Clamp, 1/2" EMT Coated	P07584	1
18	Bolt, M6x30 5.8 Hex Head Full Thread	F81001-13	1
19	Nut, M6-8 Hex Zinc	F81031-1	1
20	Washer, 6.4 Flat Zinc	F81053-1	1
	Stud Bolt Assembly, Arm Lever Connection	094204	1

3**BLADE GUIDE ROLLERS & ARM***Blade Guide Arm Assembly*

21	Bolt, Zinc-plated Stud	094203-1	1	
22	Seat, 16 DIN71805-A BN488 Ball	093824	2	
23	Stud, 16/SW-13 DIN71803-C BN486 Ball	093823	2	
24	Nut, M10-8-B Hex Zinc	F81033-3	2	
25	Washer, 10.5 Flat Zinc	F81055-1	2	
26	Nut, M10-8-B Hex Nylon Zinc Lock	F81033-1	2	
	Lever Assembly, Blade Guide Arm Adjustment	093812	1	
27	Lever, Blade Guide Arm Adjustment Painted	093813-1	1	
28	Cover, RRWA-91626-110 Grip	086875	1	
29	Bolt, 10/M8x35 12.9 ISO7379 Shoulder	F81003-63	1	
30	Bushing, XFM-1012-09	093822	2	
31	Washer, 8.4 Flat Zinc	F81054-1	1	
32	Nut, M8-8-B Hex Nylon Zinc Lock	F81032-2	1	

SECTION 4 BLADE WHEELS & TENSIONER

4.1 Blade Wheel Assembly, Drive Side

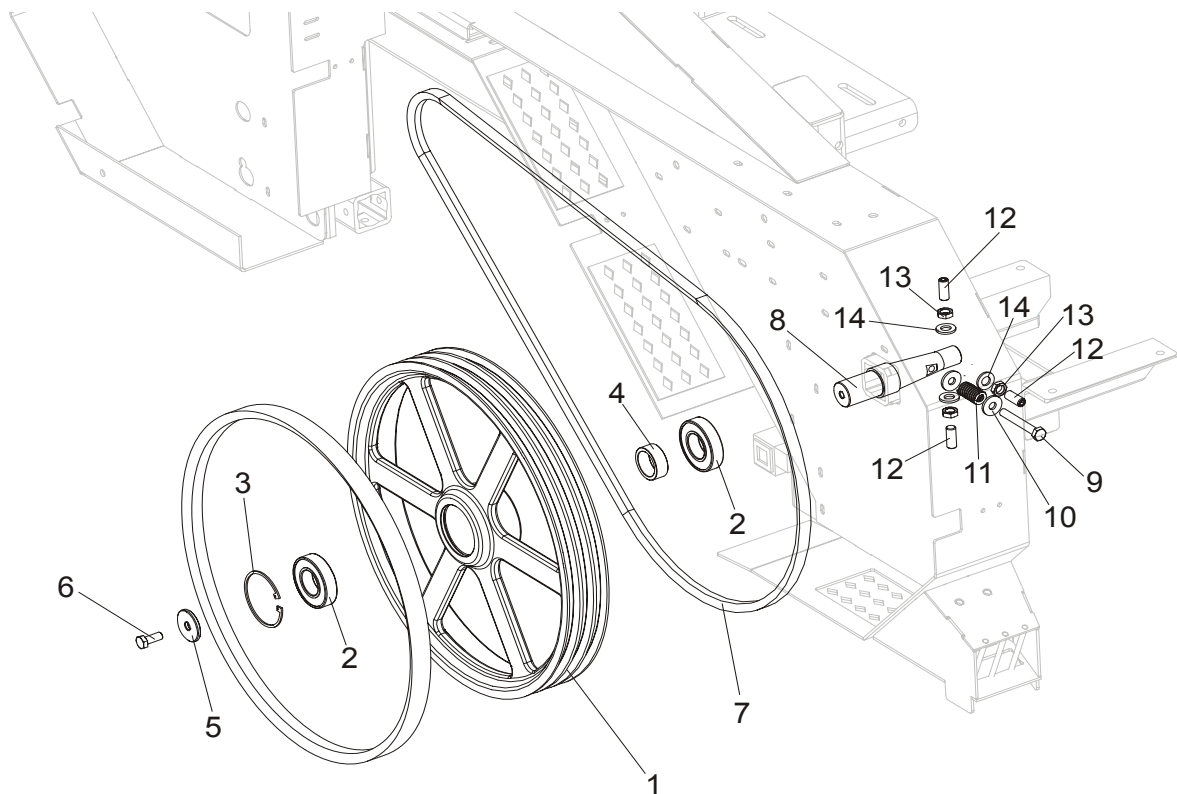

REF	DESCRIPTION (◆ Indicates Parts Available In Assemblies Only)	PART #	QTY.
	BLADE WHEEL ASSEMBLY, LT15 DRIVE SIDE	093849	1
1	Wheel, LT15 Drive Side Blade	014727	1
2	Bearing, 6207-2RS 35x72x17 FAG	014811	2
3	Ring, 72mm N5002-281 Retaining	F04254-30	1
4	Bushing, LT15 Bearing Spacer	093851	1
5	WASHER, LT15 DRIVE SIDE BLADE WHEEL	086286	1
6	BOLT, M10X25-8.8 HEX HEAD FULL THREAD ZINC	F81003-11	1
7	V-BELT, BX81, LT15	014819	1
8	SHAFT, LT15 DRIVE SIDE BLADE WHEEL	093850	1
9	BOLT, M10X75-8.8 HEX HEAD ZINC	F81003-15	1
10	WASHER, 10.5 SPECIAL FLAT ZINC	F81055-6	2
11	SPRING, 19X38 COMPRESSION	034430	1
12	SCREW, M12X1,25X30 DIN913 SET STAINLESS STEEL	F81016-1	3
13	NUT, M12X1.25 DIN439 THIN STAINLESS STEEL	F81034-9	3
14	WASHER, 13 FLAT ZINC	F81056-1	3

4 Blade Wheels & Tensioner

Blade Wheel Assembly, Idle Side

4.2 Blade Wheel Assembly, Idle Side

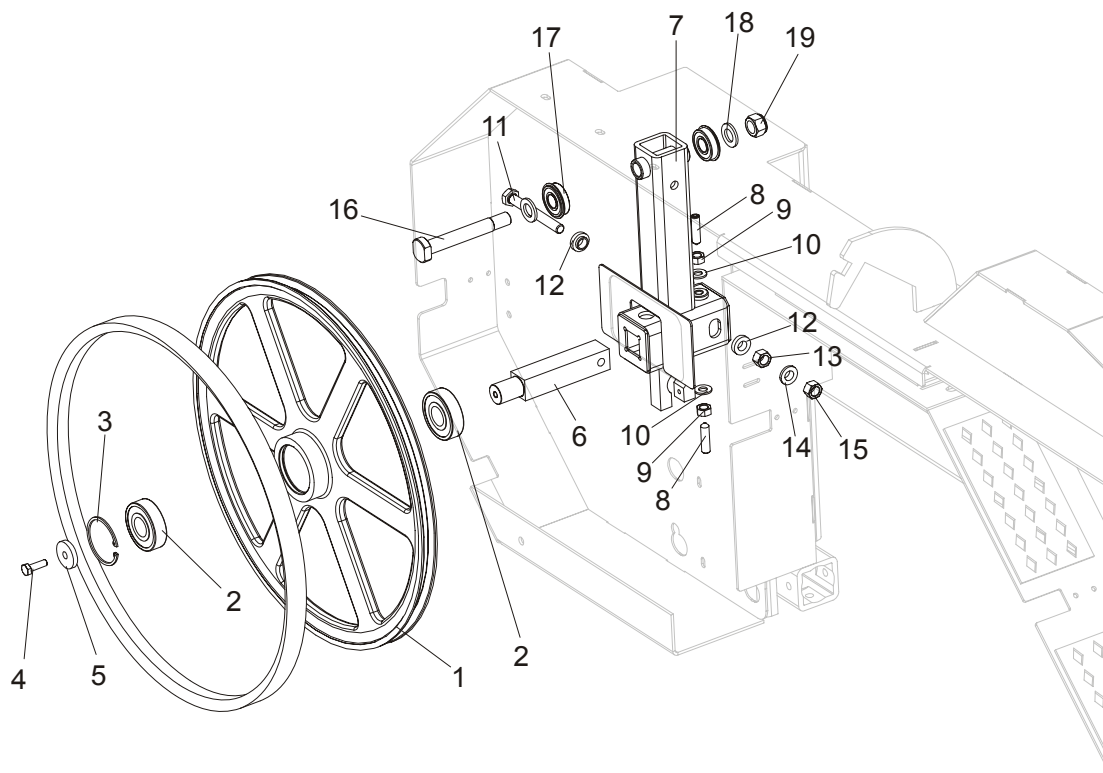

REF	DESCRIPTION (◆ Indicates Parts Available In Assemblies Only)	PART #	QTY.
	WHEEL ASSEMBLY, 19" (482.6MM) BLADE IDLE SIDE	A08218	1
1	Wheel, 18.62" Blade Idle Side	P08125	1
2	Bearing, 6305 2RS NSK Idle Side Wheel	P08066	2
3	Ring, 2 7/16" Inside Retaining	F04254-21	1
4	BOLT, M8X25-8.8-B HEX HEAD FULL THREAD ZINC	F81002-5	1
5	WASHER, IDLE SIDE WHEEL RETAINING	093854-1	1
6	SHAFT, IDLE SIDE BLADE WHEEL (METRIC)	096045	1
7	HOUSING, IDLER SHAFT	093857	1
8	SCREW, M10X40-45H HEX SOCKET SET CONE POINT ZINC	F81003-61	2
9	NUT, M10-8-B HEX ZINC	F81033-3	2
10	WASHER, 10.5 FLAT ZINC	F81055-1	2
11	BOLT, M12X1.25X100-8.8 HEX HEAD FULL THREAD ZINC	F81004-41	1
12	WASHER, FLANGED ZINC-PLATED	086769-1	2
13	NUT, M12X1.25-8 HEX ZINC	F81034-8	1
14	WASHER, Z12.2 SPLIT LOCK ZINC	F81056-2	1
15	NUT, M12X1.25 8.8 HEX THIN ZINC	F81034-5	1
16	BOLT, BEARING MOUNT	086404	1
17	BEARING, 6203-2RS NR NSK W/SNAP RING	086395	2
18	WASHER, 17 FLAT ZINC	F81058-1	2
19	NUT, M16-8 HEX NYLON ZINC LOCK	F81036-2	1

4.3 Blade Tensioner Assembly

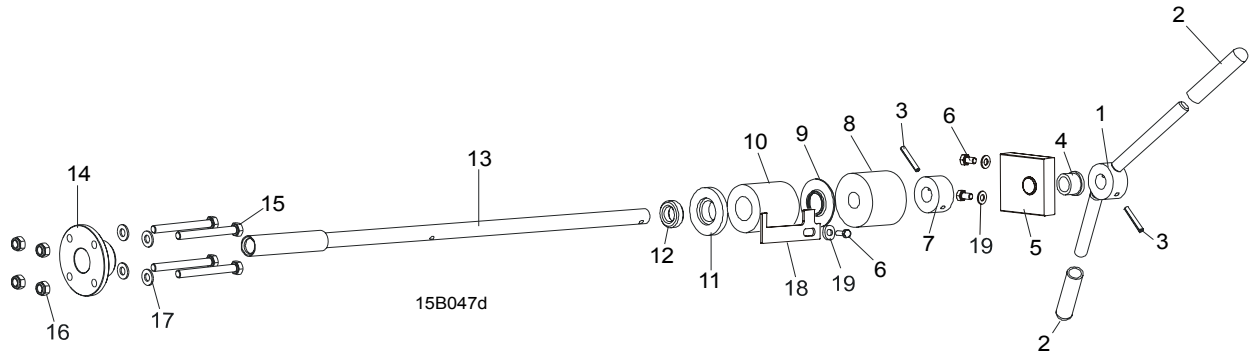

REF	DESCRIPTION (◆ Indicates Parts Available In Assemblies Only)	PART #	QTY.
	LT15 BLADE TENSIONER ASSEMBLY	086680	1
1	Handle, Blade Tension Zinc-plated	086677-1	1
2	Grip, 1/2" I.D. x 3" Blade Tension Handle	014835	2
3	Pin, 5 x 30 Roll Zinc	F81044-21	2
4	Bracket, Tension Handle Mount w/Bushing	096729	1
5	Bushing GFM-1618-17(IGUS)	089589	1
6	Bracket, Painted	096730	1
7	Bolt, M6x16 8.8 Hex Head Full Thread Zinc	F81001-15	3
8	Collar, Blade Tensioner Retaining	086712-1	1
9	Bushing, Rubber Stop	P12165	1
10	Guide, LT15 Tension Handle	014925	1
11	Spring, Blade Tensioner	014828	1
12	Washer, Rubber Spring Front	086674-1	1
13	Bearing, 51103 FLT Thrust Ball	086675	1
14	Shaft Weldment, Blade Tensioner Zinc-plated	086669-1	1
15	Nut, Blade Tensioner Painted	086672-1	1
16	Bolt, M8x70 8.8 Hex Head Zinc	F81002-71	4
17	Nut, M8-8-B Hex Nylon Zinc Lock	F81032-2	4
18	Washer, 8.4 Flat Zinc	F81054-1	8
19	INDICATOR, LT15/LT20 BLADE TENSION ZINC-PLATED	092467-1	1
20	WASHER, 6.4 FLAT ZINC	F81053-1	5
20	BOLT, M6X12-8.8 HEX HEAD FULL THREAD ZINC	F81001-7	1

4 Blade Wheels & Tensioner

Motor Assembly

4.4 Motor Assembly

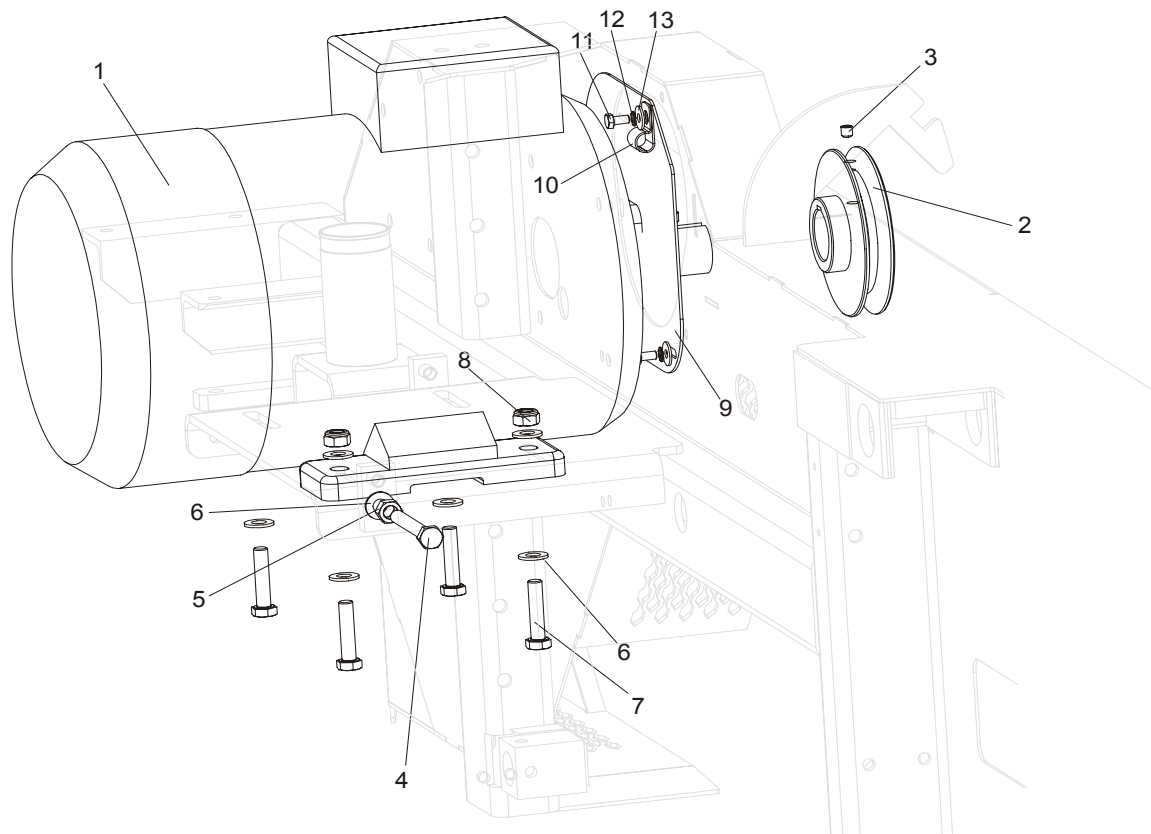

REF	DESCRIPTION (◆ Indicates Parts Available In Assemblies Only)	PART #	QTY.
1	MOTOR, 7.5KW (11HP) 380-420V 50HZ ELECTRIC	085482	1
2	PULLEY, LT15 E11 MOTOR ZINC-PLATED	086807-1 ¹	1
3	SCREW, M8X8-33H HEX SOCKET SET FLAT POINT ZINC	F81014-1	1
4	BOLT, M10X80-8.8 HEX HEAD FULL THREAD ZINC	F81003-76	2
5	NUT, M10-8-B HEX ZINC	F81033-3	2
6	WASHER, 10.5 FLAT ZINC	F81055-1	10
7	BOLT, M10X45-8.8 HEX HEAD FULL THREAD ZINC	F81003-3	4
8	NUT, M10-8-B HEX NYLON ZINC LOCK	F81033-1	4
9	MOTOR SHAFT COVER, PAINTED, E11, E15	086787	1
10	CLAMP, 1/2" EMT COATED	P07584	1
11	BOLT M6X12-8.8-FE/ZN5	F81001-7	3
12	WASHER, M6, STAR, LOCK, ZINC	F81053-2	3
13	WASHER, 6,5 POW.FE/ZN5 EXT	F81053-11	3

¹ LT15 for Russian market is equipped with motor pulley No. 091560-1.

4.5 Power Cord Bracket

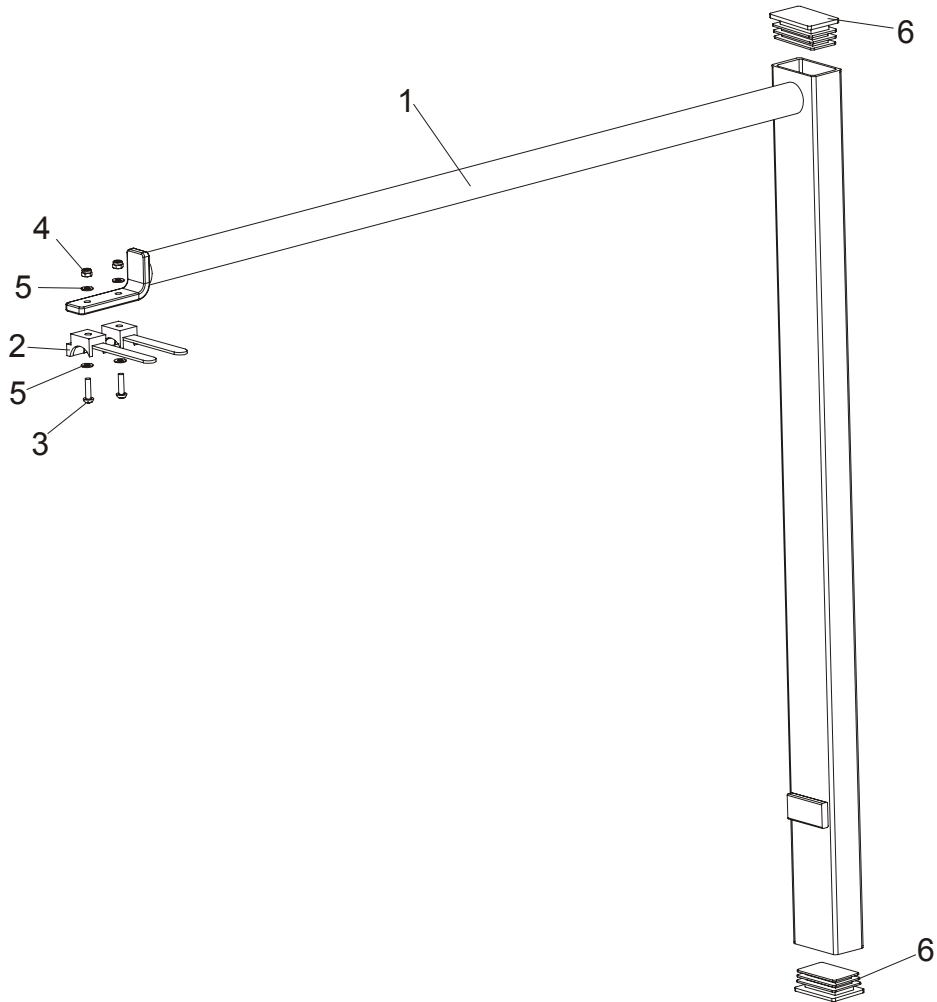

REF	DESCRIPTION (◆ Indicates Parts Available In Assemblies Only)	PART #	QTY.
	BRACKET, LT15 POWER CORD COMPLETE	097449	1
1	Bracket, LT15 Power Cord Painted	086132-1	1
2	Holder, UP30 Cable Plastic Tie	F81082-1	2
3	Screw, M4x16 5.8-B Cross Recessed Pan Head Zinc	F81011-42	2
4	Nut, M4-B Hex Nylon Zinc Lock	F81029-1	2
5	Washer, 4.3 Flat Zinc	F81051-2	4
6	Cap, 50x30 Black	095919	2

SECTION 5 SAW HEAD

5.1 Blade Housing Cover

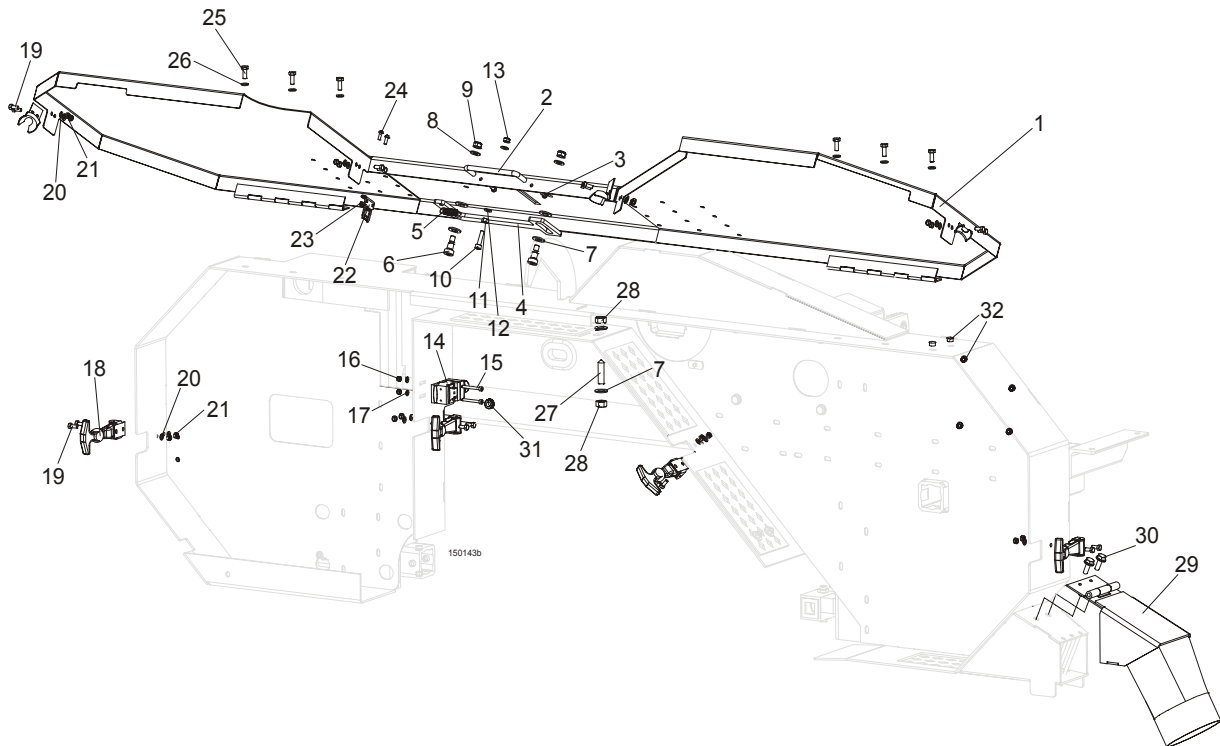

REF	DESCRIPTION (◆ Indicates Parts Available In Assemblies Only)	PART #	QTY.
1	COVER WELDMENT, BLADE HOUSING PAINTED	090633-1	1
2	HANDLE W/BOLT	P08065	1
3	SCREW, #8-32X3/8 SELF-TAPPING	F05015-8	2
4	PAWL, LOCKING PAINTED	090643-1	1
5	SPRING, 1.6X12X38 EXTENSION	092208	1
6	BOLT, 10/M8X12-12.9 ISO-7379 SHOULDER	F81003-62	2
7	WASHER, 10.5 FLAT ZINC	F81055-1	4
8	WASHER, 8.4 FLAT ZINC	F81054-1	2
9	NUT, M8-8-B HEX NYLON ZINC LOCK	F81032-2	2
10	SCREW, M6X25-8.8 HEX SOCKET HEAD CAP ZINC	F81001-41	1
11	NUT, M6-8 HEX ZINC	F81031-1	1
12	WASHER, 6.4 FLAT ZINC	F81053-1	2
13	NUT, M6-8-B HEX NYLON ZINC LOCK	F81031-2	1
14	SWITCH, AZ17-11ZRK SAFETY	094232	1
15	SCREW, M4X35-8.8 HEX SOCKET HEAD CAP ZINC	F81011-34	2
16	NUT, M4-B HEX NYLON ZINC LOCK	F81029-1	2
17	WASHER, 4.3 FLAT ZINC	F81051-2	2

18	LATCH, FLEXIBLE DRAW	014829	4	
19	BOLT, M5X12-5.8 HEX HEAD FULL THREAD ZINC	F81000-5	8	
20	WASHER, 5.3 FLAT ZINC	F81052-1	8	
21	NUT, M5-8 DIN 985 ZINC-PLATED	F81030-2	8	
22	KEY, A217/170-B5 SAFETY SWITCH	094422	1	
23	NUT, M4-B HEX NYLON ZINC LOCK	F81029-1	2	
24	SCREW, M4X12-5.8-B CROSS RECESSED PAN HEAD ZINC	F81011-43	2	
25	BOLT, M6X16 8.8 HEX HEAD FULL THREAD ZINC	F81001-15	6	
26	WASHER, 6.4 FLAT ZINC	F81053-1	6	
27	SCREW, M10X40-45H HEX SOCKET SET CONE POINT ZINC	F81003-61	1	
28	NUT, M10-8-B HEX ZINC	F81033-3	2	
29	CHUTE, SAWDUST	092460-1	1	
30	BOLT, M8X16-8.8-B HEX HEAD FULL THREAD ZINC	F81002-20	2	
31	GROMMET, 22mm DIA. RUBBER	087400	1	
32	PLUG, SR1086-9,5	096846	6	

5.2 Water Lube Assembly

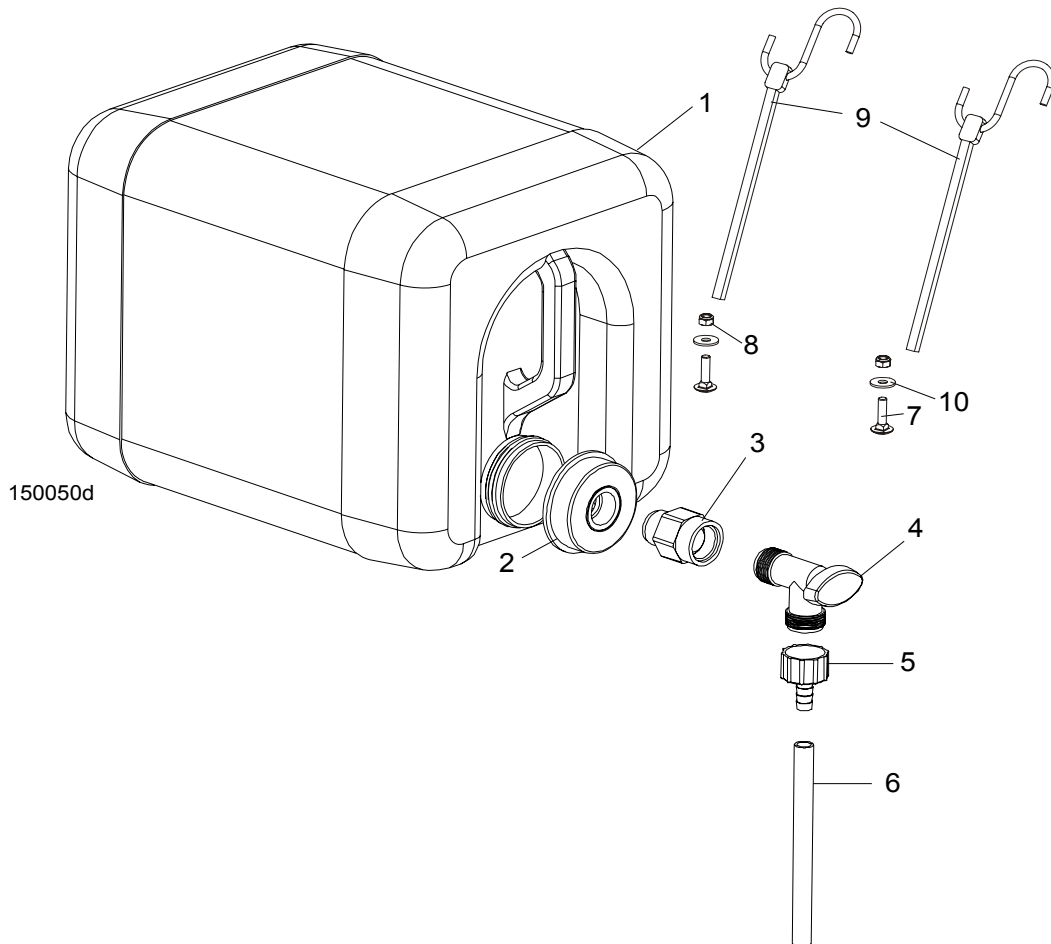

REF	DESCRIPTION (◆ Indicates Parts Available In Assemblies Only)	PART #	QTY.
1	Bottle, 5-gallon Water	014637	1
2	Cap, Water Lube Bottle	014773	1
3	Fitting, 3/4FPT x 3/4MPT Reducer	014636	1
4	Fitting, Water Lube Shutoff Valve	014100	1
5	Fitting, 5/8" NPT to 3/8" Hose Barb	014113	1
6	Tube, 3/8" I.D. Water Lube	R01885	1,7 m
7	Bolt, M6x25-8.8 Mushroom Head Square Neck Zinc	F81001-20	2
8	Nut, M6-8-B Hex Nylon Zinc Lock	F81031-2	2
9	Strap, 24" Rubber w/Hook	P11258	2
10	Washer, 6.5 Special Flat Zinc	F81053-11	2

5.3 Saw Head Decals

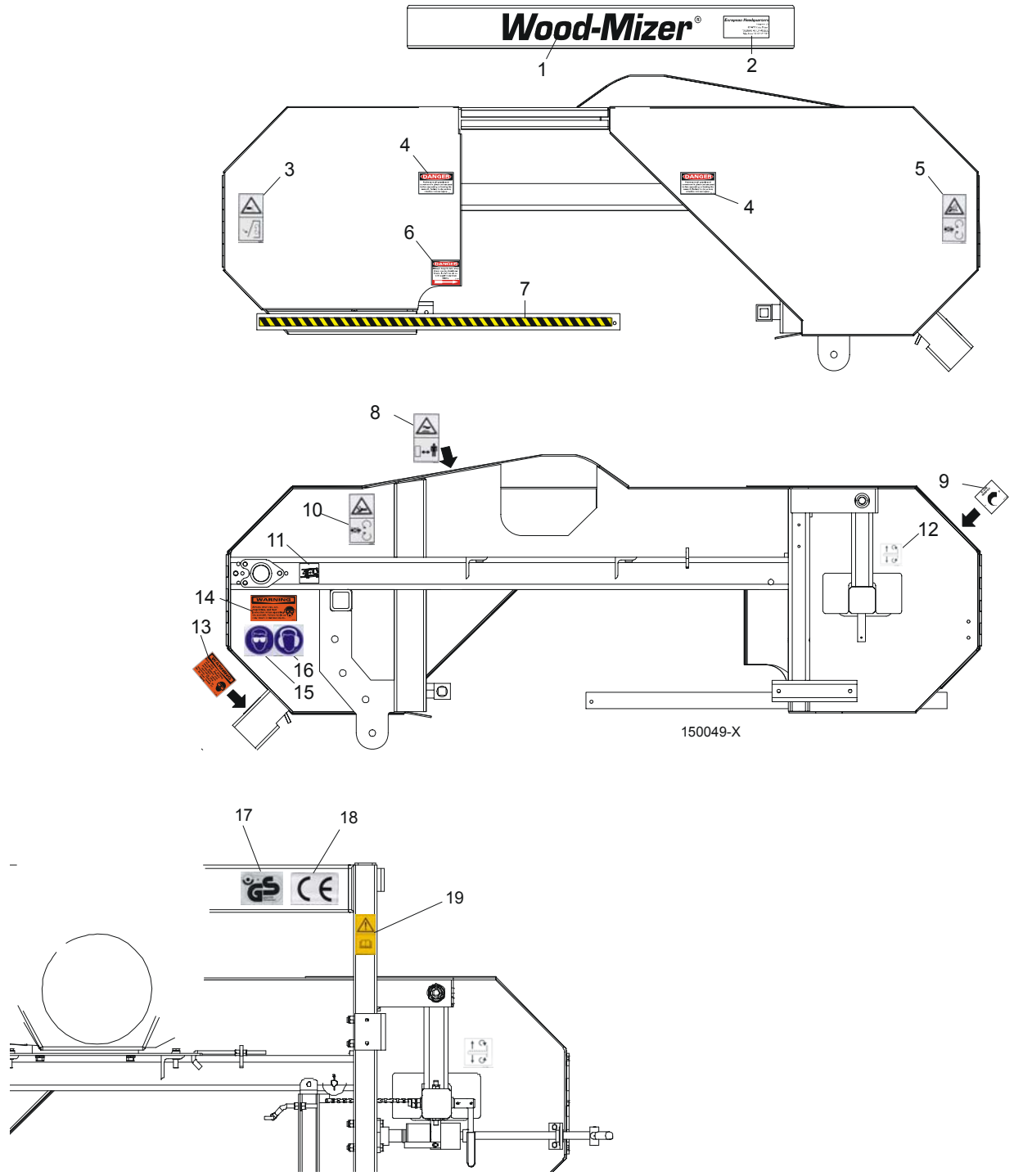

REF	DESCRIPTION (◆ Indicates Parts Available In Assemblies Only)	PART #	QTY.
	DECAL KIT, LT15 SAWMILL	085267-4	1
1	DECAL "WOOD-MIZER"	S12281	1
2	DECAL, EUROPEAN HEADQUARTERS ADDRESS	015841	1

5

Saw Head*Saw Head Decals*

3	DECAL, SHUT COVERS	086097	1	
4	DECAL, BLADE COVER DANGER	S20039	2	
5	DECAL, ROTATING MOTOR PARTS DANGER	086098	1	
6	DECAL, BLADE DANGER ARROW RIGHT	S11752	1	
7	DECAL, LT15 BLADE GUIDE BAR	015849	1	
8	DECAL, KEEP AWAY - HOT PARTS	086099	1	
9	DECAL, TENSION SCREW	P11790	1	
10	DECAL, BLADE MOVEMENT WARNING	086096	1	
11	DECAL, BLADE GUIDE ADJUSTMENT	086093	1	
12	DECAL, BLADE ALIGNMENT	P11789	1	
13	DECAL, SAWDUST CHUTE WARNING	P11754	1	
14	DECAL, EYE/EAR PROTECTION WARNING	S11753	1	
15	DECAL, EYE PROTECTION WARNING	S12004G	1	
16	DECAL, EAR PROTECTION WARNING	S12005G	1	
17	DECAL, GS SAFETY CERTIFICATION (SMALL)	P85072	1	
18	DECAL, CE CERTIFIED SAWMILL (SMALL)	P85070	1	
19	DECAL, READ MANUALS BEFORE OPERATING THE MACHINE	086095	1	
	DECAL, POWER FEED & UP/DOWN SYSTEMS ENGAGEMENT (NOT SHOWN)	086094	1	
	DECAL, LT15 CENTIMETER SCALE (NOT SHOWN)	086142	1	
	DECAL, POWER FEED & UP/DOWN SYSTEMS ENGAGEMENT (NOT SHOWN)	086094	1	

5.4 Control Box

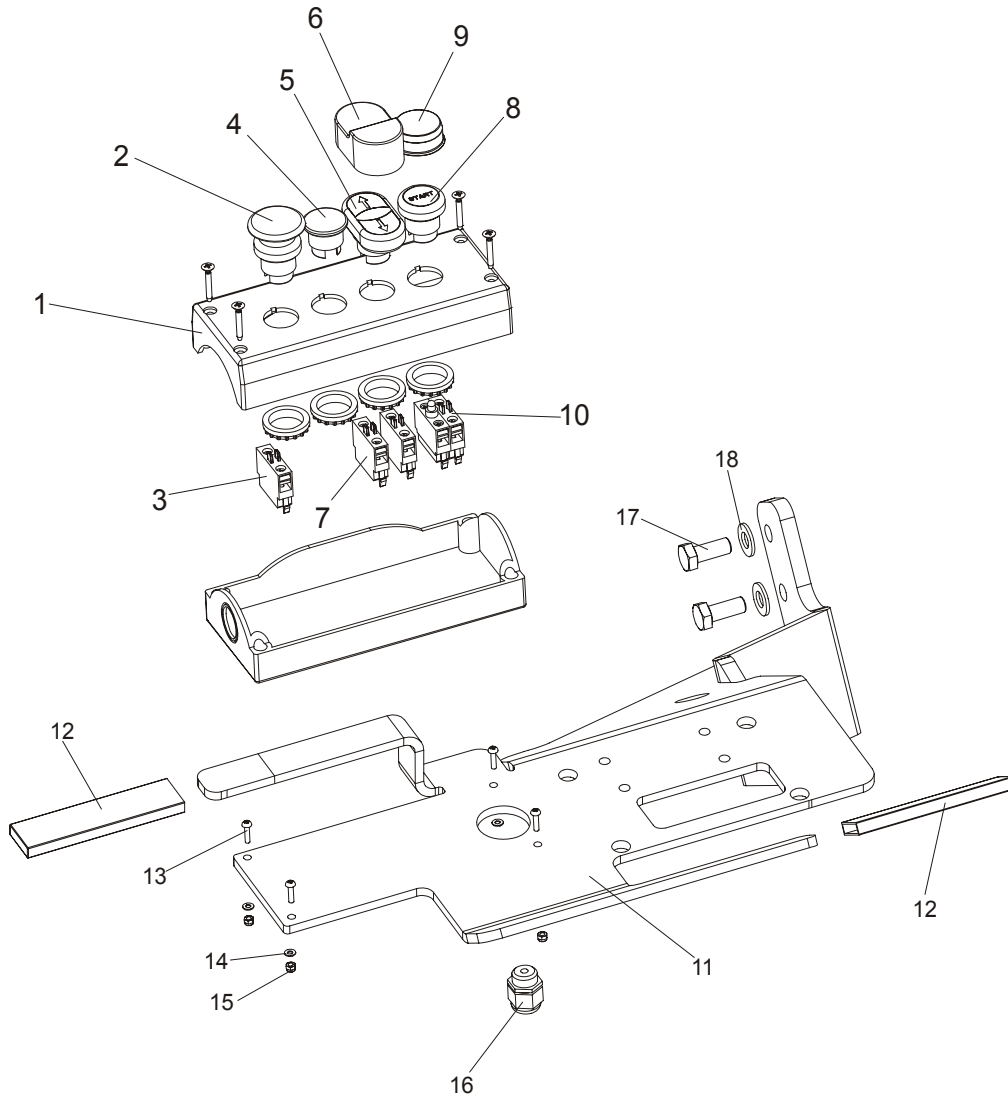

REF	DESCRIPTION (◆ Indicates Parts Available In Assemblies Only)	PART #	QTY.
	CONTROL BOX, LT15 AC COMPLETE W/ MOUNT BRACKET	094195	1
	Control Box, LT15 Complete	094258	1
1	Body, Control Box	094259	1
2	Button, M22 Momentary Mushroom Red	094328	1
3	Element, M22-KC10 Contact	094314	1
4	Cap, M22-B (216388)	093748	1
5	Button, M22-DD-S-X7/X7	090917	1
6	Boot, M22-T-DD	090462	1
7	Element, M22-KC10 1 Contact	094314	2
8	Button, Green Illuminated START	094315	1
9	Boot	094316	1
10	Element, M22-KC10 Contact	094314	1

5**Saw Head***Control Box*

11	Bracket, Control Box Mount Painted	094233-1	1	
12	Cover, RRWA-91626-110 Grip	086875	2	
13	Screw, M4x16 5.8-B Cross Recessed Pan Head Zinc	F81011-42	4	
14	Washer, 4.3 Flat Zinc	F81051-2	4	
15	Nut, M4-B Hex Nylon Zinc Lock	F81029-1	2	
16	Gland, DP 13/H Cable	F81096-4	1	
17	Washer, Flat, M10, Zinc	F81055-1	2	
18	Bolt, M10-1.5x25mm HH Gr 8.8	F81003-11	2	

5.5 Electric Box

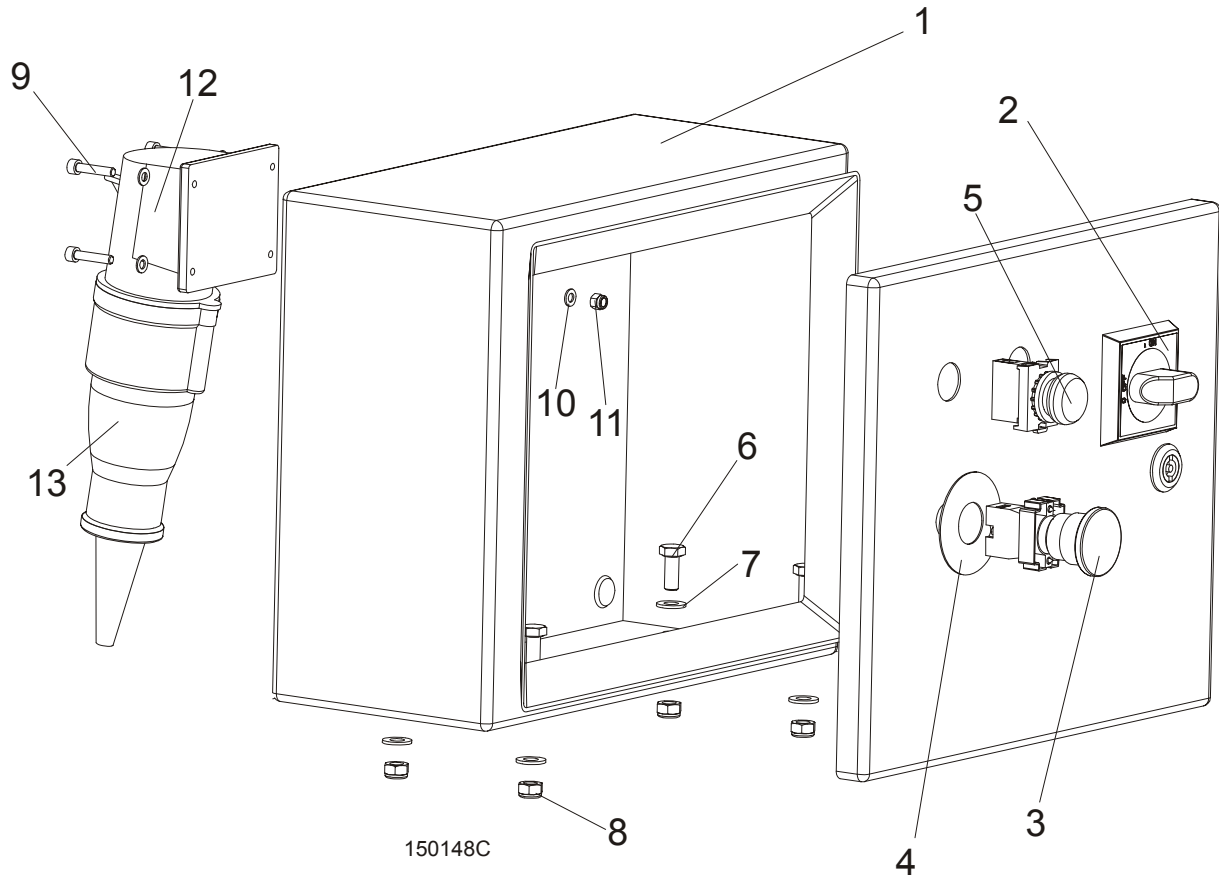

REF	DESCRIPTION (◆ Indicates Parts Available In Assemblies Only)	PART #	QTY.
1	ELECTRIC BOX, LT15AC	094237	1
2	Knob, OHB2AJ ABB Selector Switch	088265-1	1
3	Button, XB4 BS542 Emergency Stop	086556	1
4	Washer, ZBY9330 E-Stop Button	086561	1
5	Light, M22 LED 24V White Control	090448	1
6	Bolt, M8x20-8.8-B Hex Head Full Thread Zinc	F81002-4	4
7	Washer, 8.4 Flat Zinc	F81054-1	8
8	Nut, M8-8-B Hex Nylon Zinc Lock	F81032-2	4
9	Bolt, M5x20-8.8 Socket Head Zinc	F81000-72	4
10	Washer, 5.3 Flat Zinc	F81052-1	4
11	Nut, M5-8 Hex Nylon Zinc Lock	F81030-2	4
12	Plug, 16A 5P 2607 BALS	E85239	1
13	Socket, 16A 400V IP57 31243 BALS	E85240	1

SECTION 6 FEED SYSTEM

6.1 Feed Crank Assembly

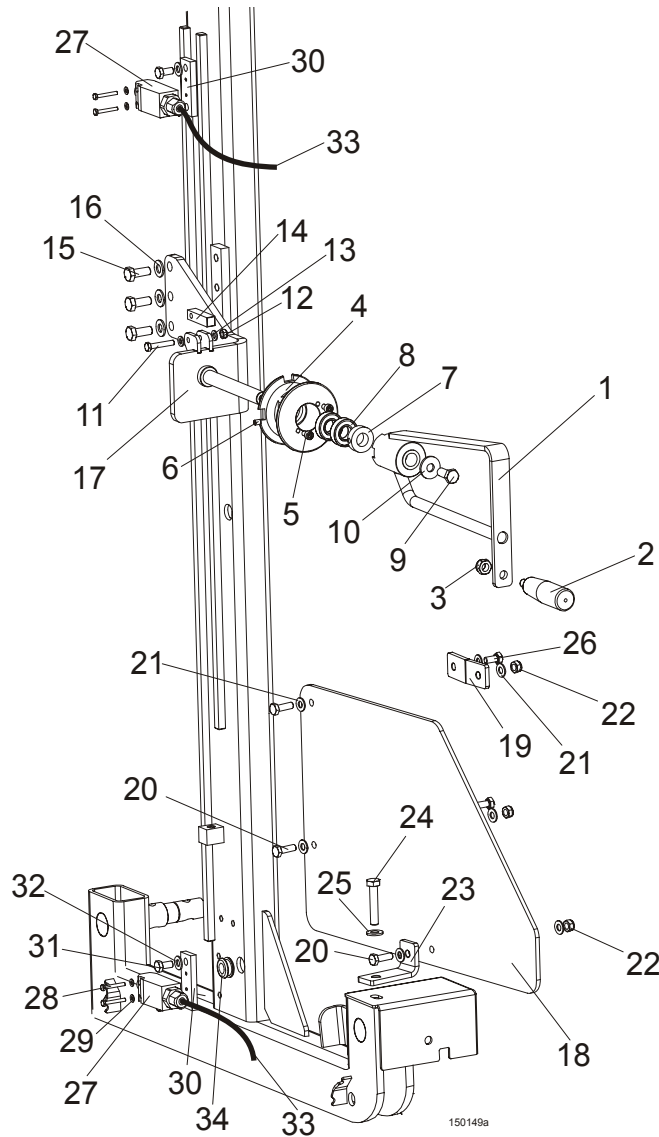

REF	DESCRIPTION (◆ Indicates Parts Available In Assemblies Only)	PART #	QTY.
	MANUAL FEED SYSTEM	094186	1
	Feed Crank Assembly	094260	1
1	Crank Weldment, Feed Painted	094191-1	1
2	Knob, 12992M10 Plastic Crank Handle	086338	1
3	Nut, M10-8-B Hex Nylon Zinc Lock	F81033-1	1
4	Pulley, LT15 Feed Rope	086117	1
5	Screw, M6x10-8.8 Hex Socket Head Cap Zinc	F81001-12	2
6	Screw, M6x8 Hex Socket Set Cone Point Zinc	F81013-1	1

7	Ring, 17 Stopping Light Type Zinc-plated	F81039-1	1	
8	Bearing, 6003-2RS FAG Rolling	086116	2	
9	Bolt, M10x25-8.8 Hex Head Full Thread Zinc	F81003-11	1	
10	Washer, 10.5 Special Flat Zinc	F81055-6	1	
11	Bolt, M6x35 8.8 Hex Head Zinc	F81001-71	1	
12	Nut, M6-8-B Hex Nylon Zinc Lock	F81031-2	1	
13	Washer, 6.4 Flat Zinc	F81053-1	2	
14	Pawl, LT15 Detent Zinc-plated	086156-1	1	
15	Bolt, M10x25-8.8 Hex Head Full Thread Zinc	F81003-11	3	
16	Washer, 10.5 Flat Zinc	F81055-1	3	
17	Bracket Weldment, Feed Rope Pulley Painted	094187-1	1	
	GUARD, LT15 COMPLETE LOWER	093858	1	
18	Plate, LT15 Lower Guard	093859	1	
19	Bracket, Side Painted	086171-1	2	
20	Bolt, M8x25-8.8-B Hex Head Full Thread Zinc	F81002-5	3	
21	Washer, 8.4 Flat Zinc	F81054-1	6	
22	Nut, M8-8-B Hex Nylon Zinc Lock	F81032-2	3	
23	Bracket, Lower Painted	086172-1	1	
24	BOLT, M10X50-8.8 HEX HEAD FULL THREAD ZINC	F81003-4	1	
25	WASHER, 10.5 FLAT ZINC	F81055-1	1	
26	BOLT, M8X16-8.8-B HEX HEAD FULL THREAD ZINC	F81002-20	1	
	EVN2000C LIMIT SWITCH W/MOUNT PLATE	094227	2	
27	Switch, EVN2000 C Limit	089816	1	
28	Bolt, M4x30 8.8 Hex Head Full Thread Zinc	F81011-5	2	
29	Washer, 4.3 Flat Zinc	F81051-2	2	
30	Plate, Limit Switch Mount Painted	094228-1	1	
31	Bolt, M8x16 -8.8-B Hex Head Full Thread Zinc	F81002-20	2	
32	Washer, 8.4 Flat Zinc	F81054-1	2	
33	Cable, OLFLEX 400P 2x1	R80583-5	3m	
34	GROMMET, 20/13 RUBBER	086188	1	

6.2 Track Rail, Rollers & Travel Pins

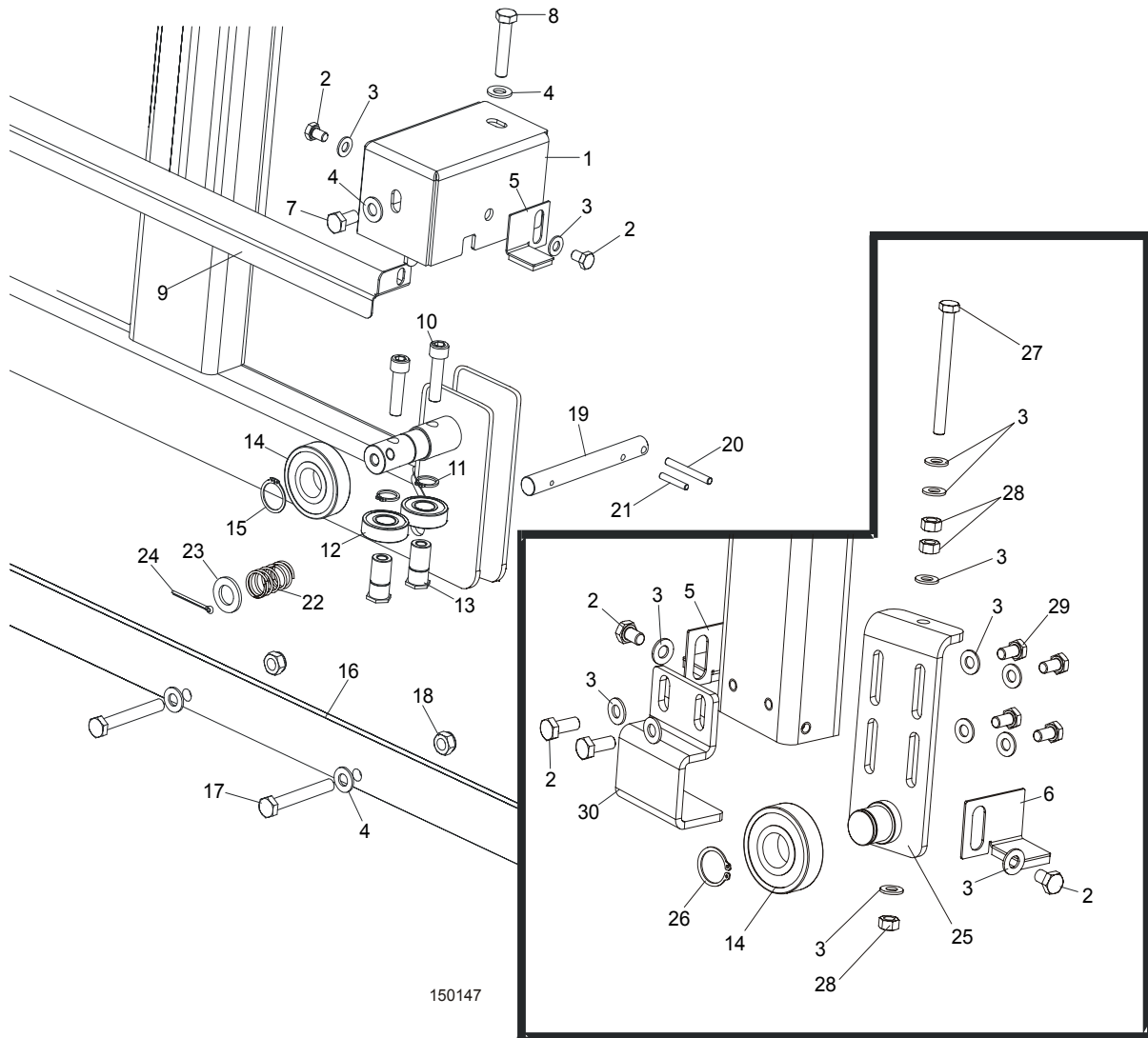

150147

REF	DESCRIPTION (◆ Indicates Parts Available In Assemblies Only)	PART #	QTY.
1	HOUSING, TRACK ROLLER PAINTED	086739-1	2
2	BOLT, M8X12-8.8 HEX HEAD FULL THREAD ZINC	F81002-6	8
3	WASHER, 8.4 FLAT ZINC	F81054-1	16
4	WASHER, 10.5 FLAT ZINC	F81055-1	13
5	PLATE, LT15 RIGHT TRACK WIPER PAINTED	086324-1	2
6	PLATE, LT15 LEFT TRACK WIPER PAINTED	086325-1	2
7	BOLT, M10 X 20 5.8 HEX HEAD FULL THREAD ZINC	F81003-1	2
8	BOLT, M10X50-8.8 HEX HEAD FULL THREAD ZINC	F81003-4	2
9	COVER, MIDDLE TRACK	086745	1

10	SCREW, M10X40 HEX SOCKET HEAD CAP ZINC	F81003-22	4	
11	RING, Z 17 OUTSIDE RETAINING	F81090-21	4	
12	BEARING, 6203-2RS ROLLING	086114	4	
13	SHAFT, SIDE BEARING MOUNT ZINC-PLATED	086645-1	4	
14	BEARING, 6305-2RS CX	085706	3	
15	RING, 25MM RETAINING	F04254-26	2	
16	RAIL, LT15 1950 (LT15S3) TRACK ZINC-PLATED	094427-1	3	
	RAIL, LT15 2700 (LT15M2) TRACK ZINC-PLATED	094696-1	2	
17	BOLT, M10X75-8.8 HEX HEAD ZINC	F81003-15	9/13 ¹	
18	NUT, M10-8-B HEX NYLON ZINC LOCK	F81033-1	9/13 ²	
19	PIN, TRAVEL LOCK ZINC-PLATED	086743-1	2	
20	PIN, 6X50 ROLL ZINC	F81045-1	2	
21	PIN, 5 X 30 ROLL ZINC	F81044-21	2	
22	SPRING, 18X37X1.8 COMPRESSION ZINC-PLATED	087301	2	
23	WASHER, 17 FLAT ZINC	F81058-1	2	
24	PIN, 4 X 25 COTTER ZINC	F81043-2	2	
25	BRACKET WELDMENT, IDLE SIDE ROLLER PAINTED	094198-1	1	
26	RING, 25Z OUTSIDE RETAINING	F81090-22	1	
27	BOLT, M8X90-8.8 HEX HEAD FULL THREAD ZINC	F81002-16	1	
28	NUT, M8-8-B HEX ZINC	F81032-1	3	
29	BOLT, M8X16-8.8-B HEX HEAD FULL THREAD ZINC	F81002-20	4	
30	GUIDE, LT15 MAST IDLE SIDE PAINTED	086202-1	1	

¹ Number of bolts for one bed section.

² Number of nuts for one bed section.

6.3 Feed Rope, V-groove Rollers & Brackets

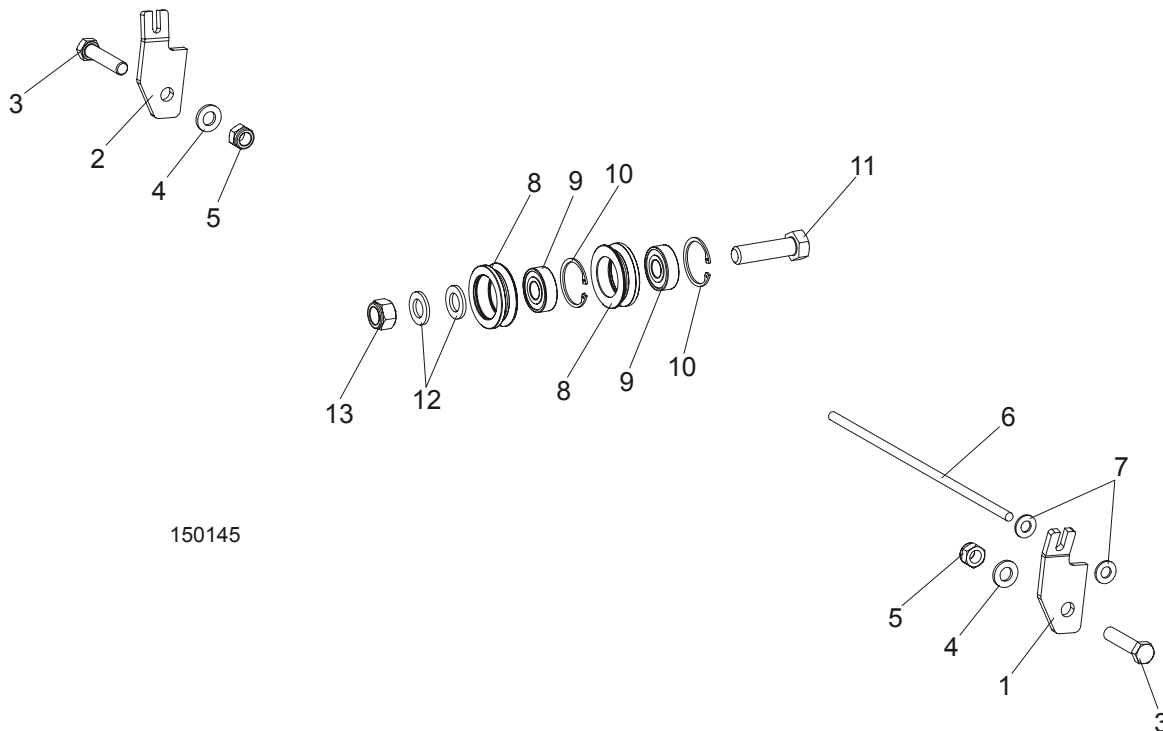

150145

REF	DESCRIPTION (◆ Indicates Parts Available In Assemblies Only)	PART #	QTY.
1	BRACKET, LT15 ROPE MOUNT FRONT PAINTED	092569-1	1
2	BRACKET, LT15 ROPE MOUNT REAR PAINTED	092570-1	1
3	BOLT, M12X55-8.8 HEX HEAD ZINC	F81004-12	2
4	WASHER, 13 FLAT ZINC	F81056-1	2
5	NUT, M12-8-B HEX ZINC	F81034-1	2
6	ROPE, 5/16" DIA. BRAIDED POLYESTER	R02080	9,0 m
7	WASHER, 10.5 FLAT ZINC	F81055-1	2
	ROLLER ASSEMBLY, V-GROOVE W/BEARING	093855	2
8	Roller, V-groove Zinc-plated	093856-1	1
9	Bearing, 6203 2RS 5/8 CX	095087	1
10	Ring, W40 Inside Retaining	F81090-3	1
11	BOLT, M16X60 8.8 HEX HEAD FULL THREAD ZINC	F81006-12	1
12	WASHER, 17 FLAT ZINC	F81058-1	2
13	NUT, M16-8 HEX NYLON ZINC LOCK	F81036-2	1

SECTION 7 UP/DOWN SYSTEM

7.1 AC Up/Down Drive Assembly

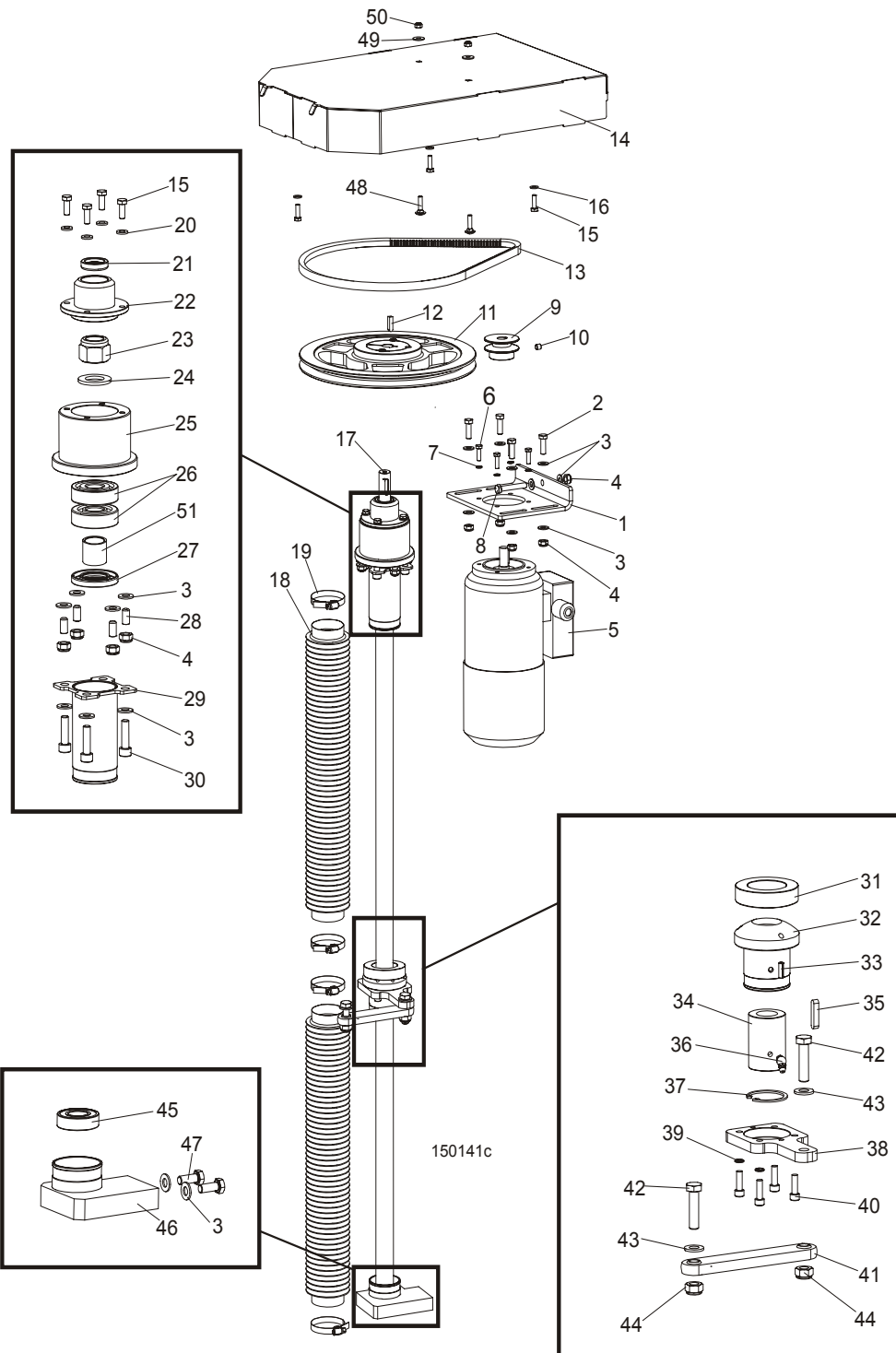

7

Up/Down System

AC Up/Down Drive Assembly

REF	DESCRIPTION (◆ Indicates Parts Available In Assemblies Only)	PART #	QTY.	
	UP/DOWN DRIVE - AC, COMPLETE	094143	1	
1	Plate, Drive Belt Tension	094162-1	1	
2	Bolt, M8x25-8.8-B Hex Head Full Thread Zinc	F81002-5	4	
3	Washer, 8.4 Flat Zinc	F81054-1	22	
4	Nut, M8-8-B Hex Nylon Zinc Lock	F81032-2	9	
5	Motor, AC Up/Down Drive	094161	1	
6	Bolt, M6x20-8.8 Hex Head Full Thread Zinc	F81001-2	4	
7	Washer, Z 6.1 Split Lock Zinc	F81053-3	4	
8	Bolt, M8x50-8.8 Hex Head Full Thread Zinc	F81002-19	1	
9	Pulley, Up/Down Motor	094160-1	1	
10	Screw, M8x8-33H Hex Socket Set Flat Point Zinc	F81014-1	1	
11	Pulley, SPA 280/1 w/18 Split Taper Bushing	094157	1	
12	Key, AB 6x6x23 Parallel	089191	1	
13	V-belt, AVX-13x1100 La	095306	1	
14	Guard Weldment, Up/Down Drive Complete	095327	1	
15	Bolt, M6x20-8.8 Hex Head Full Thread Zinc	F81001-2	8	
16	Washer, 6.4 Flat Zinc	F81053-1	4	
17	Screw, Tr 28x5 Acme	094144	1	
18	Bellows, 50/700 Protective	094208	2	
19	Clamp, 40-60mm	F81095-4	4	
20	Washer, 6.4 Flat Zinc	F81053-1	4	
21	Ring, A018x30x7 Sealing	094159	1	
22	Cover, Up/Down Bearing Housing	094165-1	1	
23	Nut, M20x1.5-8-A2 ISO10512 Self-locking	F81037-5	1	
24	Washer, 21 Flat Zinc	F81059-2	1	
25	Housing, Up/Down Bearings	094164-1	1	
26	Bearing, 7304B -UO CX	094256	2	
27	Ring, A28x52x7 Sealing	094155	1	
28	Screw, M8x16-33H Hex Socket Set Flat Point	F81014-2	4	
29	Bracket, Upper Bellows Mount Zinc-plated	094221-1	2	
30	Screw, M8x30-8.8 Hex Socket Head Cap Zinc	F81002-31	4	
31	Washer, DIN6319-42-C Spherical Seat	F81061-7	1	
	Up/Down Nut Assembly	094150	1	
32	Housing, TR28x5 Acme Nut Zinc-plated	094241-1	1	
33	Pin, 5x16 Roll Zinc	F81044-3	2	
34	Nut, Tr 28x5 (PET T) Acme Screw	094243	1	
35	Key, A6x6x30 Parallel	094245	1	
36	Fitting, M6 "B" Type PN-M/86003 Grease	094213	1	
37	Ring, W40 Inside Retaining	F81090-3	1	
38	Plate, Nut Housing Seat	094242-1	1	
39	Washer, Z 6.1 Split Lock Zinc	F81053-3	4	
40	Screw, M6x20-8.8 Hex Socket Head Cap Zinc	F81001-22	4	
41	Link, SBPL 10104 Pivotal	097700	1	
42	Bolt, M10x40-8.8 Hex Head Full Thread Zinc	F81003-16	2	
43	Washer, 10.5 Flat Zinc	F81055-1	2	

44	Nut, M10-8-B Hex Nylon Zinc Lock	F81033-1	2	
45	Bearing, 6004 2RS-CX Rolling	093868	1	
46	Seat, Lower Bearing	093866-1	1	
47	Bolt, M8x20-8.8-B Hex Head Full Thread Zinc	F81002-4	2	
48	Bolt, M6x25-8.8 Mushroom Head Square Neck Zinc	F81001-20	2	
49	Washer, 6.5 Special Flat Zinc	F81053-11	2	
50	Nut, M6-8-B Hex Nylon Zinc Lock	F81031-2	2	
51	Spacer, LT15 Drive Bearing	094156-1	1	

7.2 Slide Pads & Blade Height Scale Indicator

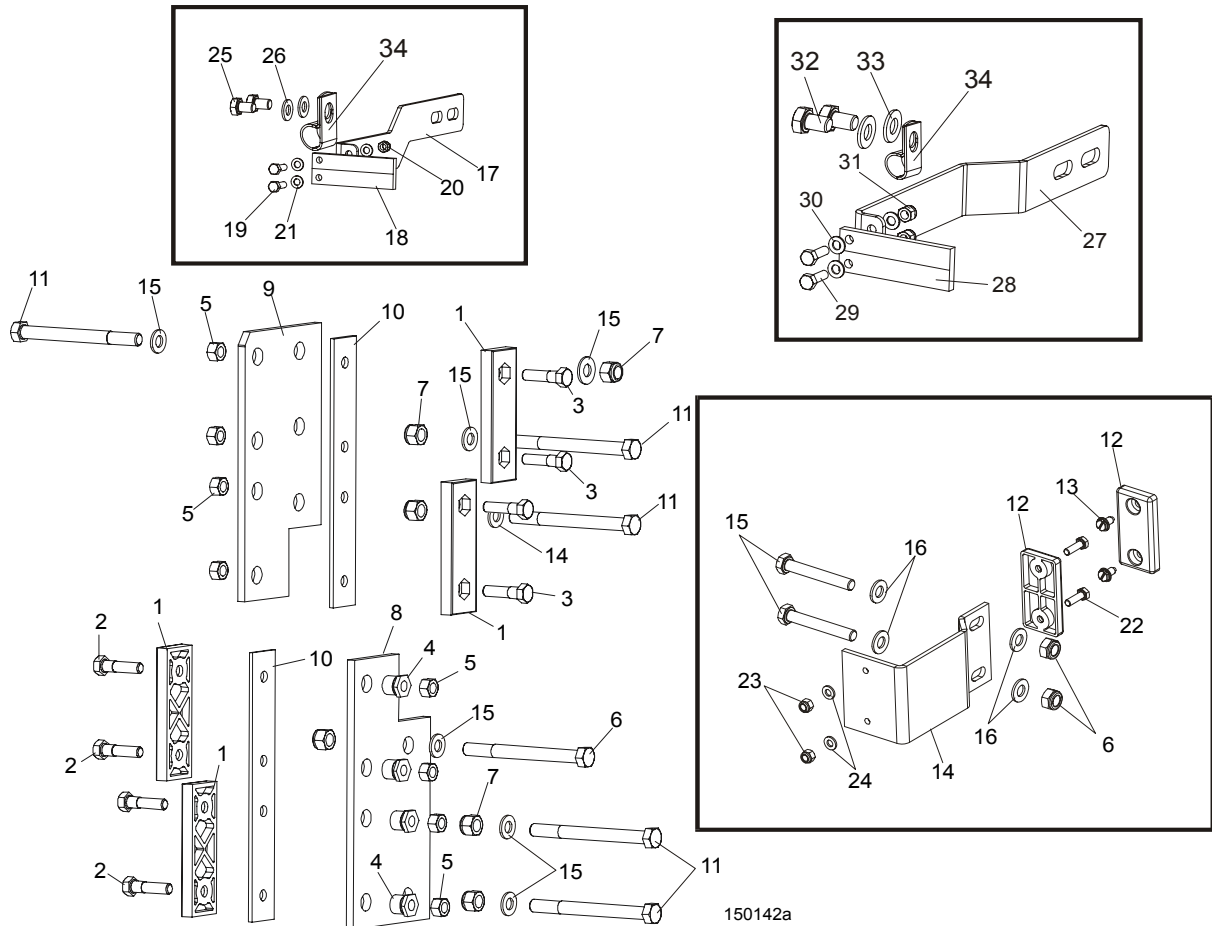

REF	DESCRIPTION (◆ Indicates Parts Available In Assemblies Only)	PART #	QTY.
1	PADS, DELRIN UP/DOWN SLIDE	M04096	4
2	BOLT, M8X35-8.8 HEX HEAD FULL THREAD ZINC	F81002-13	4
3	BOLT, M8X20-8.8 HEX HEAD FULL THREAD ZINC	F81002-4	4
4	NUT, LT15 SLIDE PAD ADJUSTMENT	086683-1	4
5	NUT, M8-8-B HEX NYLON ZINC LOCK	F81032-2	8
6	BOLT, M10X110 8.8 HEX HEAD ZINC	F81003-43	1
7	NUT, M10-8-B HEX NYLON ZINC LOCK	F81033-1	8
8	PLATE, SAW HEAD LOWER GUIDE PAINTED	086682-1	1
9	PLATE, SAW HEAD UPPER GUIDE PAINTED	094139-1	1
10	PLATE, SLIDE PAD SPACER PAINTED	094140-1	2
11	BOLT, M10X115-8.8 HEX HEAD ZINC	F81003-19	5
12	PAD, IDLE SIDE SLIDE	P13576	2
13	SCREW, 1/4-20 X 1/2" "23" TYPE SELF-TAPPING	F05015-1	2
14	GUIDE, LT15 SAW HEAD PAINTED	087192-1	1

15	BOLT, M10X70-8.8 HEX HEAD FULL THREAD ZINC	F81003-20	2	
16	WASHER, 10.5 FLAT ZINC	F81055-1	11	
	SCALE INDICATOR (STANDARD)	094226	1	
17	Bracket, Scale Indicator Mount Painted	094224-1	1	
18	Indicator, Blade Height Scale	094821	1	
19	Bolt, M5NX16-8.8 Hex Head Full Thread Zinc	F81000-20	2	
20	Nut, M5-8 DIN 985 Zinc-Plated	F81030-2	2	
21	Washer, 5.3 Flat Zinc	F81052-1	4	
22	BOLT, M6X20-8.8 HEX HEAD FULL THREAD ZINC	F81001-2	2	
23	NUT, M6-8-B HEX NYLON ZINC LOCK	F81031-2	2	
24	WASHER, 6.4 FLAT ZINC	F81053-1	2	
25	BOLT, M8X12-8.8 HEX HEAD FULL THREAD ZINC	F81002-6	2	
26	WASHER, 8.4 FLAT ZINC	F81054-1	2	
	SCALE INDICATOR (OPTIONAL)	095967		
27	Bracket, Scale Indicator Mount Painted	095968-1	1	
28	Indicator, Blade Height Scale	094821	1	
29	Bolt, M5X16-8.8 Hex Head Full Thread Zinc5	F81000-20	2	
30	Washer, 5.3 Flat Zinc	F81052-1	4	
31	Nut, M5-8 DIN 985 Zinc-plated	F81030-2	2	
32	Bolt, M8x12-8.8 Hex Head Full Thread Zinc	F81002-6	2	
33	Washer, 8.4 Flat Zinc	F81054-1	2	
34	CLAMP, 1/2" EMT COATED	P07584	1	

7 Up/Down System

Blade Height Scale & Up/Down Limit Switches

7.3 Blade Height Scale & Up/Down Limit Switches

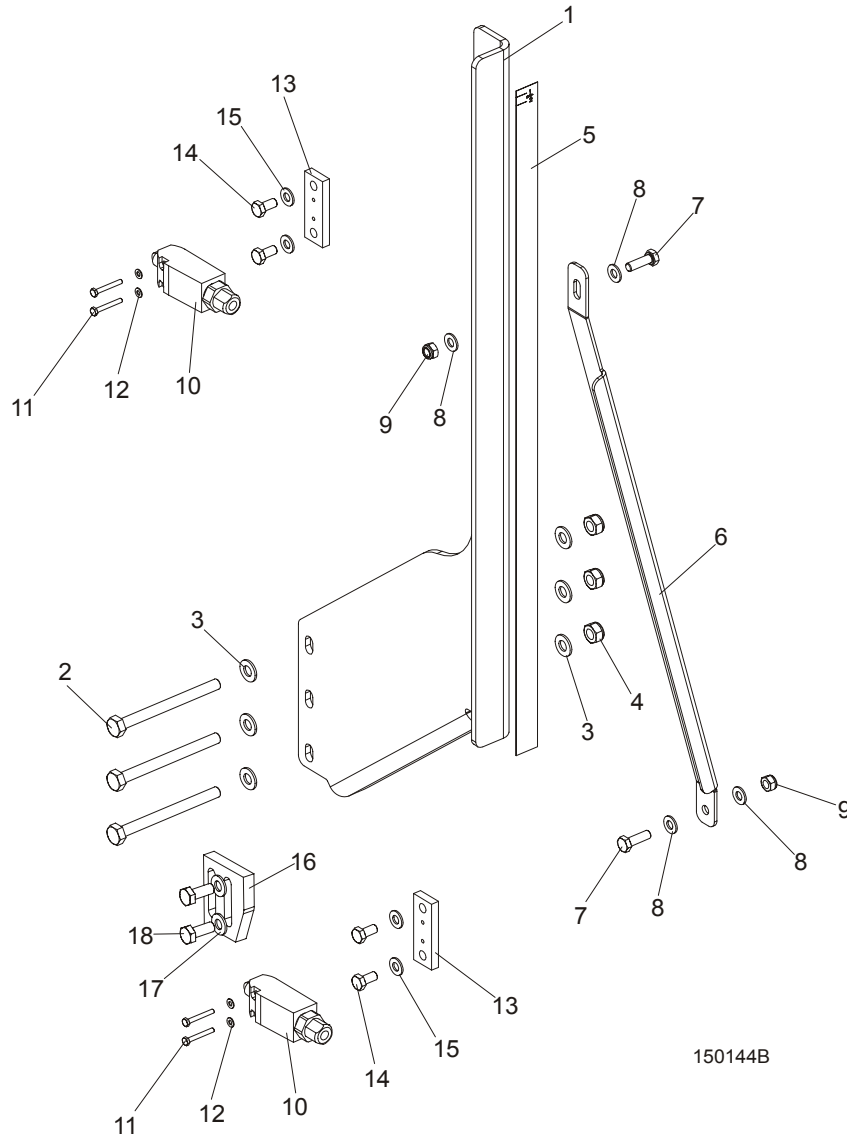

REF	DESCRIPTION (◆ Indicates Parts Available In Assemblies Only)	PART #	QTY.
	BRACKET, BLADE HEIGHT SCALE, COMPLETE	094225	1
1	Bracket, Blade Height Scale, Painted	094223-1	1
2	Bolt, M10X115-8.8 Hex Head Zinc	F81003-19	3
3	washer, 10.5 flat zinc	F81055-1	6
4	Nut, M10-8-B Hex Nylon Zinc Lock	F81033-1	3
5	Decal, LT15AC Blade Height Metric Scale	094151	1
	Decal, LT15AC Blade Height Inch Scale	096658	1
6	BRACKET, BLADE HEIGHT SCALE MOUNT PAINTED	094257-1	1
7	BOLT, M8X25-8.8-B HEX HEAD FULL THREAD ZINC	F81002-5	2

8	WASHER, 8.4 FLAT ZINC	F81054-1	4	
9	NUT, M8-8-B HEX NYLON ZINC LOCK	F81032-2	2	
	EVN2000C LIMIT SWITCH W/MOUNT PLATE	094227	2	
10	Switch, EVN2000 C Limit	089816	1	
11	Bolt, M4x30 8.8 Hex Head Full Thread Zinc	F81011-5	2	
12	Washer, 4.3 Flat Zinc	F81051-2	2	
13	Plate, Limit Switch Mount	094228-1	1	
14	Bolt, M8x16-8.8-B Hex Head Full Thread Zinc	F81002-20	2	
15	Washer, 10.5 Flat Zinc	F81055-1	2	
16	BRACKET, LIMIT SWITCH	094229-1	1	
17	WASHER, 8.4 FLAT ZINC	F81054-1	2	
18	BOLT, M8X20MM, HEX HEAD,GR 5.8 ZINC	F81002-4	2	

7.4 Blade Height Scale (Optional)

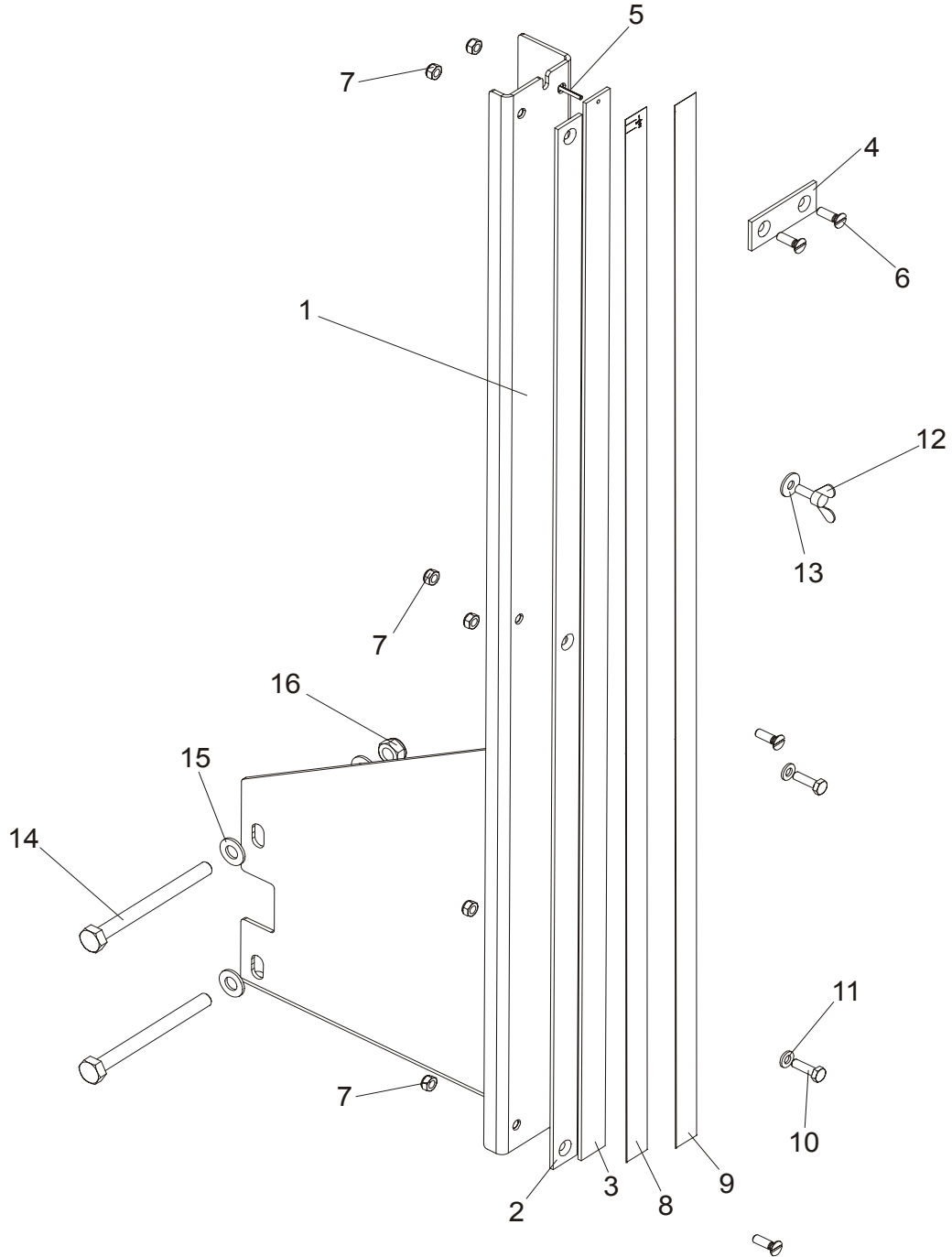

REF	DESCRIPTION (◆ Indicates Parts Available In Assemblies Only)	PART #	QTY.
	BRACKET, BLADE HEIGHT SCALE COMPLETE	095964	1
1	Bracket, Blade Height Scale Painted	095965-1	1
2	Plate, Decal Mount	092750	1
3	Plate, Inch Decal Mount	093133	1

4	BAR, SCALE MOUNT	093134	1	
5	PIN, 3x20 ROLL ZINC	F81044-5	1	
6	screw, M6x20- 4.8-B slotted countersunk head zinc	F81001-31	3	
7	Nut, M6-8-B hex nylon zinc lock	F81031-2	6	
8	decal, LT20 0-80CM centimeter scale	091239	1	
9	Decal, 16-40CM Metric Decal, 45-63CM Metric	P12040-1 P12040-2	1	
10	BOLT, M6X20-8.8 HEX HEAD FULL THREAD ZINC	F81001-2	2	
11	WASHER, 6.4 FLAT ZINC	F81053-1	2	
12	SCREW, M6X16 BN276 DIN 316 WING	F81001-16	1	
13	WASHER, 6.5 SPECIAL FLAT ZINC	F81053-11	1	
14	BOLT, M10X115-8.8 HEX HEAD ZINC	F81003-19	2	
15	WASHER, 10.5 FLAT ZINC	F81055-1	4	
16	NUT, M10-8-B HEX NYLON ZINC LOCK	F81033-1	2	