

# **Wood-Mizer®**

## **Replacement Parts Manual**

---

**LT15 S3 E11**  
**LT15 M2 E11**

**rev. E1.03**  
**rev. E1.03**

---



**Safety is our #1 concern!** Read and understand all safety information and instructions before operating, setting up or maintaining this machine.

*July 2005*

*Form #797*

<b>SECTION 1</b>	<b>GENERAL INFORMATION</b>	<b>1-1</b>
1.1	How To Use The Parts List .....	1-1
1.2	Sample Assembly .....	1-1
<b>SECTION 2</b>	<b>BED FRAME</b>	<b>2-1</b>
2.1	Log Side Support Assembly .....	2-1
2.2	Bed Section Connecting Hardware .....	2-2
2.3	Stationary Leg Kit .....	2-3
2.4	Outrigger Leg Kit (Mobile sawmills only).....	2-4
2.5	Log Clamp Assembly .....	2-5
2.6	Auxiliary Bed Rail Assembly .....	2-6
2.7	Log Wedge, Loading Ramps & Cant Hook (Optional).....	2-7
2.8	Bed Extension.....	2-8
2.9	”M” Type Frame Bed Section .....	2-9
2.10	”S” Type Frame Bed Section .....	2-10
2.11	Additional Bed Frame Section with Stationary Legs.....	2-11
2.12	Additional Bed Frame Section with Outrigger Legs.....	2-12
<b>SECTION 3</b>	<b>BLADE GUIDE ROLLERS &amp; ARM</b>	<b>3-1</b>
3.1	Blade Guide Assembly, Idle Side.....	3-1
3.2	Blade Guide Assembly, Drive Side.....	3-3
3.3	Blade Guide Roller Guard .....	3-5
3.4	Blade Guide Arm Assembly .....	3-6
<b>SECTION 4</b>	<b>BLADE WHEELS &amp; TENSIONER</b>	<b>4-1</b>
4.1	Blade Wheel Assembly, Drive Side .....	4-1
4.2	Blade Wheel Assembly, Idle Side.....	4-2
4.3	Blade Tensioner Assembly.....	4-4
4.4	Motor Assembly .....	4-5
4.5	Power Cord Bracket .....	4-6
<b>SECTION 5</b>	<b>SAW HEAD</b>	<b>5-1</b>
5.1	Blade Housing Cover .....	5-1
5.2	Water Lube Assembly .....	5-3
5.3	LT15AC Saw Head Decals .....	5-4
5.4	Control Box .....	5-6
5.5	Electric Box .....	5-8
<b>SECTION 6</b>	<b>FEED SYSTEM</b>	<b>6-1</b>
6.1	Feed Crank Assembly.....	6-1
6.2	Track Rail, Rollers & Travel Pins .....	6-3
6.3	Feed Rope, V-groove Rollers & Brackets.....	6-5
<b>SECTION 7</b>	<b>UP/DOWN SYSTEM</b>	<b>7-1</b>
7.1	AC Up/Down Drive Assembly.....	7-1
7.2	Slide Pads & Blade Height Scale Indicator.....	7-4
7.3	Blade Height Scale & Up/Down Limit Switches.....	7-6
7.4	Blade Height Scale (Optional).....	7-8

## SECTION 1 GENERAL INFORMATION

### 1.1 How To Use The Parts List

- Use the index above to locate the assembly that contains the part you need.
- Go to the appropriate section and locate the part in the illustration.
- Use the number pointing to the part to locate the correct part number and description in the table.
- Parts shown indented under another part are included with that part.
- Parts marked with a diamond (◆) are only available in the assembly listed above the part.

See the sample table below. Sample Part #A01111 includes part F02222-2 and subassembly A03333. Subassembly A03333 includes part S04444-4 and subassembly K05555. The diamond (◆) indicates that S04444-4 is not available except in subassembly A03333. Subassembly K05555 includes parts M06666 and F07777-77. The diamond (◆) indicates M06666 is not available except in subassembly K05555.

<b>1.2 Sample Assembly</b>				
REF	DESCRIPTION (◆ Indicates Parts Available In Assemblies Only)	PART #	QTY.	
	Sample Assembly, Complete (Includes All Indented Parts Below)	A01111	1	
1	Sample Part	F02222-22	1	
	Sample Subassembly (Includes All Indented Parts Below)	A03333	1	
2	Sample Part (◆ Indicates Part Is Only Available With A03333)	S04444-4	1	◆
	Sample Subassembly (Includes All Indented Parts Below)	K05555	1	
3	Sample Part (◆ Indicates Part Is Only Available With K05555)	M06666	2	◆
4	Sample Part	F07777-77	1	

#### **To Order Parts:**

- From Europe call our European Headquarters and Manufacturing Facility in Kolo, Poland at **+48-63-2626000**. From the continental U.S., call our toll-free Parts hotline at **1-800-448-7881**. Have your customer number, vehicle identification number, and part numbers ready when you call.
- From other international locations, contact the Wood-Mizer distributor in your area for parts.

**SECTION 2 BED FRAME**

**2.1 Log Side Support Assembly**

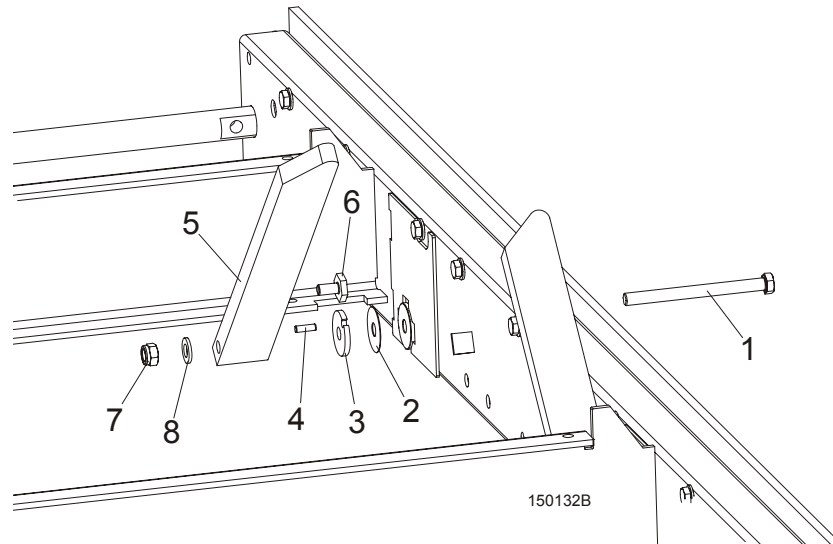

REF	DESCRIPTION (◆ Indicates Parts Available In Assemblies Only)	PART #	QTY.
1	BOLT, M12X140-8.8 HEX HEAD ZINC	F81004-35	1
2	WASHER, 33/64 X 1 3/4 X 1/32" NYLON	014972	1
3	WASHER, LT15 THICK SPACER	085981-1	1
	SUPPORT, LT15 LOG SIDE COMPLETE PAINTED	085982-1	1
4	PIN, H 6n6x20 60HRC ROLL	100472	1
5	PLATE, LT15 LOG SIDE SUPPORT	085980	1
6	BOLT, M10x20 SPECIAL	100076-1	1
7	NUT, M12-8 HEX NYLON ZINC LOCK	F81034-2	1
8	WASHER, 13 FLAT ZINC	F81056-1	1

**2.2 Bed Section Connecting Hardware**

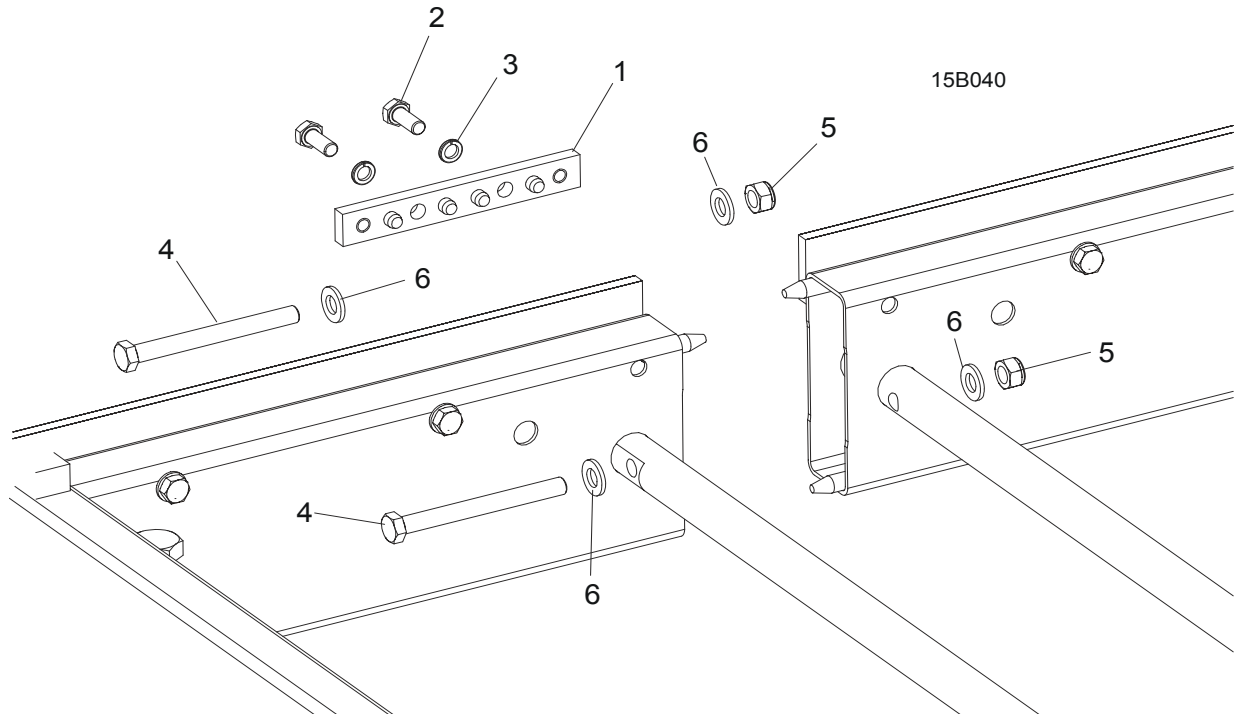

REF	DESCRIPTION (◆ Indicates Parts Available In Assemblies Only)	PART #	QTY.
1	SPLICE, TRACK RAIL PINNED	086659-1	1
2	BOLT, M10 X 25-8.8 HEX HEAD FULL THREAD ZINC	F81003-11	2
3	WASHER, 10.2 SPLIT LOCK ZINC	F81055-2	2
4	BOLT, M12X120 8.8 HEX HEAD ZINC	F81004-38	2
5	NUT, M12-8 HEX NYLON ZINC LOCK	F81034-2	2
6	WASHER, 13 FLAT ZINC	F81056-1	4

**2.3 Stationary Leg Kit**

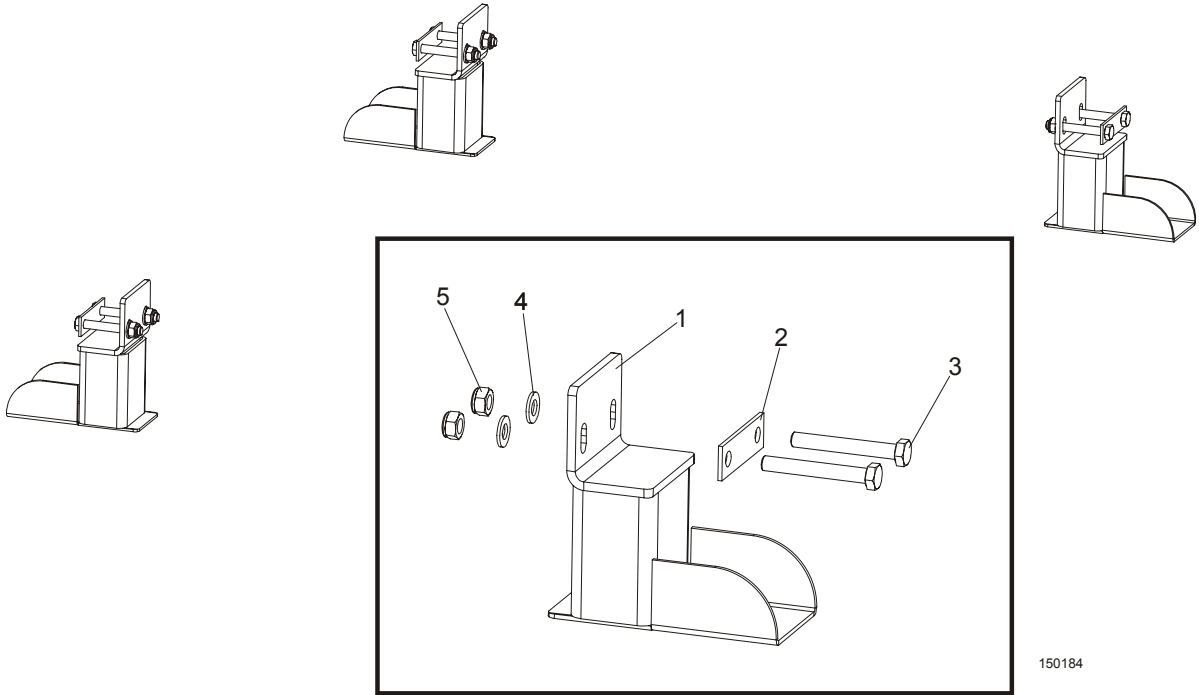

REF	DESCRIPTION (◆ Indicates Parts Available In Assemblies Only)	PART #	QTY.
	<b>STATIONARY LEG KIT FOR 1950 MM BED SECTION</b>	100069	1
1	Leg, LT15 Stationary Bed	100064-1	4
2	Washer, LT15 Bed Leg	085994-1	4
3	Bolt, M10x75-8.8 Hex Head Zinc	F81003-15	8
4	Washer, 10.5 Flat Zinc	F81055-1	8
5	Nut, M10-8-B Hex Nylon Zinc Lock	F81033-1	8
	<b>STATIONARY LEG KIT FOR 2700 MM BED SECTION</b>	100070	1
1	Leg, LT15 Stationary Bed	100064-1	6
2	Washer, LT15 Bed Leg	085994-1	6
3	Bolt, M10x75-8.8 Hex Head Zinc	F81003-15	12
4	Washer, 10.5 Flat Zinc	F81055-1	12
5	Nut, M10-8-B Hex Nylon Zinc Lock	F81033-1	12

**2.4 Outrigger Leg Kit (Mobile sawmills only)**

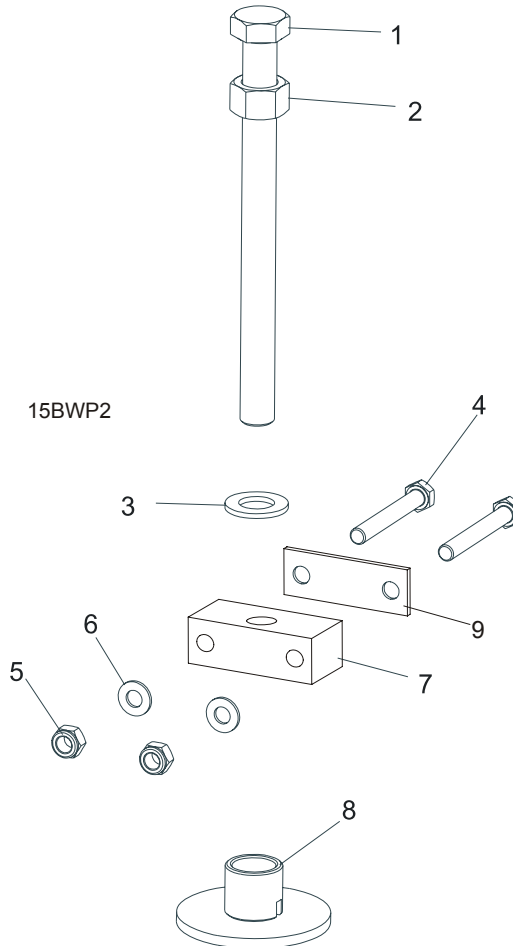

REF	DESCRIPTION (◆ Indicates Parts Available In Assemblies Only)	PART #	QTY.
	<b>OUTRIGGER LEG KIT FOR 1950 MM BED SECTION (LT15S3)</b>	095232 <sup>1</sup>	3
	<b>OUTRIGGER LEG KIT FOR 2700 MM BED SECTION (LT15M2)</b>	095234 <sup>2</sup>	2
1	Bolt, M20x240-8.8 Hex Head Full Thread Zinc	F81007-1	1
2	Nut, M20-8 Hex Zinc	F81037-1	1
3	Washer, 21 Flat Zinc	F81059-2	1
4	Bolt, M10x120-8.8 Hex Head Zinc	F81003-58	2
5	Nut, M10-8-B Hex Nylon Zinc Lock	F81033-1	2
6	Washer, 10.5 Flat Zinc	F81055-1	2
7	Block, LT15 Leg Mount	095745-1	1
8	Plate Weldment, LT15 Leg Foot Zinc-plated	087771-1	1
9	Washer, LT15 Bed	085994-1	1

<sup>1</sup> Four legs are mounted to each 1950-mm long bed section. Standard in mobile sawmills, option in stationary sawmills.

<sup>2</sup> Six legs are mounted to each 2700-mm long bed section. Option in stationary sawmills.

**2.5 Log Clamp Assembly**

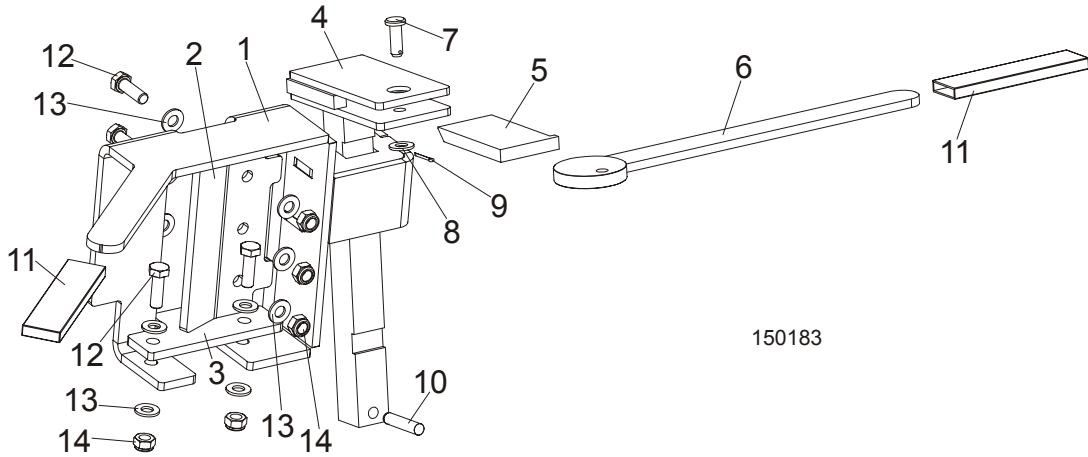

REF	DESCRIPTION (◆ Indicates Parts Available In Assemblies Only)	PART #	QTY.
	<b>LOG CLAMP ASSEMBLY, COMPLETE</b>	097553	2
1	Clamp Weldment, Zinc-plated	097514-1	1
2	Plate, Log Clamp Guide Zinc-plated	094524-1	1
3	Plate, Log Clamp Lower Zinc-plated	094525-1	1
	Log Clamp, Complete	098546	1
4	Bracket, Log Clamp Zinc-plated	086822-1	1
5	Key, Log Clamp Zinc-plated	086831-1	1
6	Cam, Log Clamp Zinc-plated	086828-1	1
7	Pin, 8x24x2x20.5-St-A2 PN-EN 22341	F81046-3	1
8	Washer, 8.4 Flat Zinc	F81054-1	1
9	Pin, 2x16-St-A2 ISO 1234 Cotter	F81041-2	1
10	Pin, H 8m6x40 Roll 60HRC DIN-6325	F81048-5	1
11	Grip, Log Clamp Handle	086875	2
12	Bolt, M8x25-8.8-B Hex Head Full Thread Zinc	F81002-5	5
13	Washer, 8.4 Flat Zinc	F81054-1	10
14	Nut, M8-8-B Hex Nylon Zinc Lock	F81032-2	5



## 2.6 Auxiliary Bed Rail Assembly

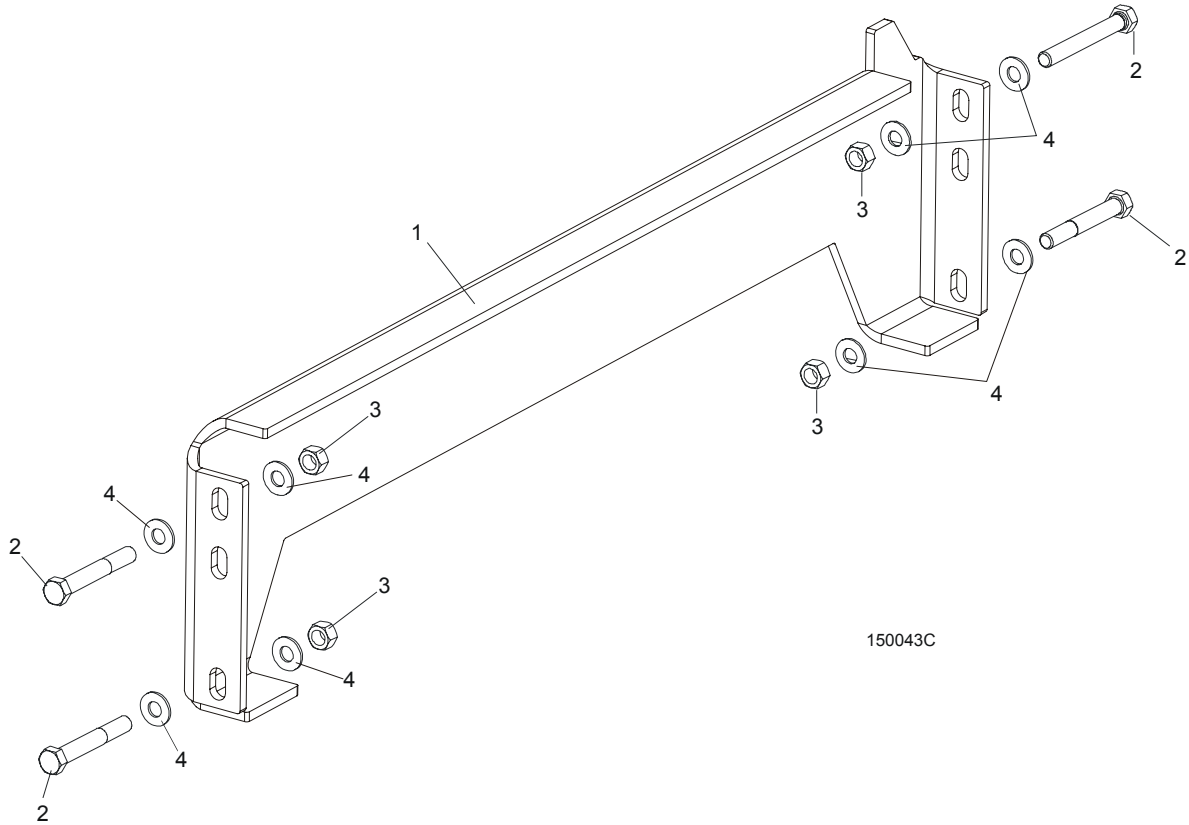

REF	DESCRIPTION (◆ Indicates Parts Available In Assemblies Only)	PART #	QTY.	
1	RAIL WELDMENT, LT15 AUXILIARY BED	095490-1	1	◆
2	BOLT M10X75-8.8 HEX HEAD ZINC	F81003-15	4	
3	NUT, M10-8-B HEX NYLON ZINC LOCK	F81033-1	4	
4	WASHER 10,5 ZINC FLAT	F81055-1	8	

**2.7 Log Wedge, Loading Ramps & Cant Hook (Optional)**

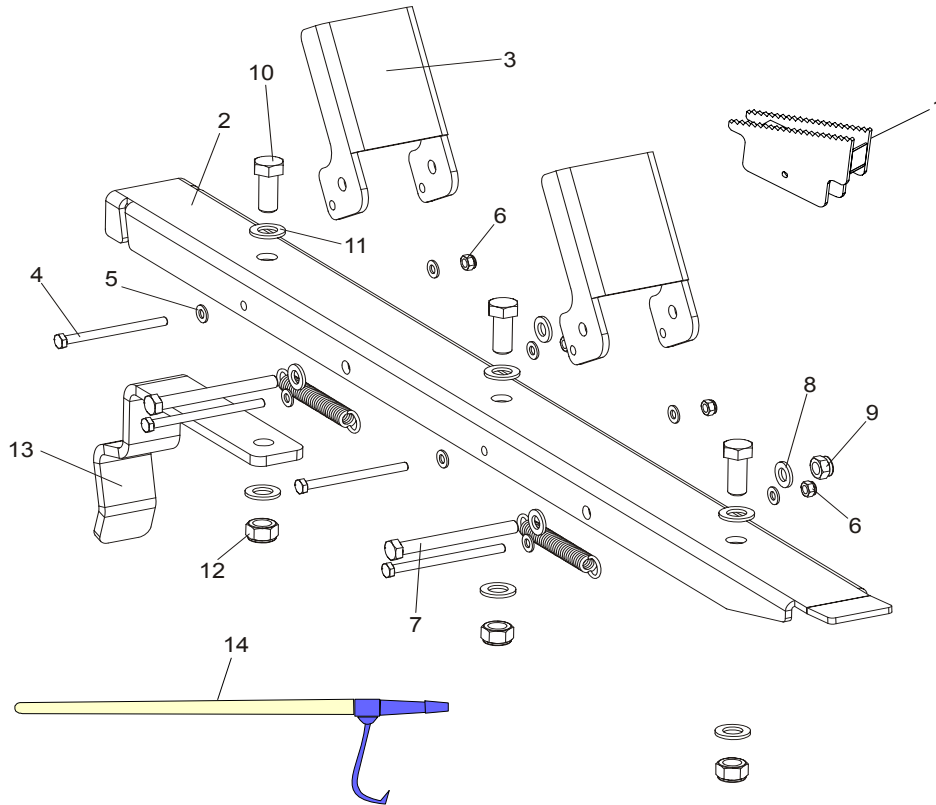

REF	DESCRIPTION (◆ Indicates Parts Available In Assemblies Only)	PART #	QTY.
	<b>ACCESSORIES, LT15 SAWMILLS</b>	085997	1
1	Wedge Weldment, Log Taper (included in 015811 kit)	<b>086035-1</b>	1
	Ramp Assembly, Log Loading, LT15 compl.	<b>097977</b>	2
	Ramp Assembly	<b>097483</b>	1
2	Ramp Weldment, zink plated	<b>097481-1</b>	1
3	Bracket, Log Loading Stop, zink plated	<b>097482-1</b>	2
4	Bolt M8x100 -8.8	<b>F81002-23</b>	4
5	Washer, M8, Flat, zinc	<b>F81054-1</b>	8
6	Nut, M8, Hexagon, Nylon lock, zinc	<b>F81032-2</b>	4
7	Bolt, M12x115-8.8-Fe/Zn5 PN-M/82101	<b>F81004-33</b>	2
8	Washer, M12 , Flat, Zinc	<b>F81056-1</b>	2
9	Nut, M12, Hexagon, Nylon, zinc,lock	<b>F81034-2</b>	2
10	Bolt, M16x40-8.8 Fe/Zn5	<b>F81006-13</b>	2
11	Washer, M16, Flat, zinc	<b>F81058-1</b>	4
12	Nut, M16, hex, nylon zinc lock	<b>F81036-2</b>	2
13	Bracket, LT15 Ramp, zinc	<b>097976-1</b>	1
14	Cant Hook ( included in 015811 kit)	<b>CH</b>	1

## 2.8 Bed Extension

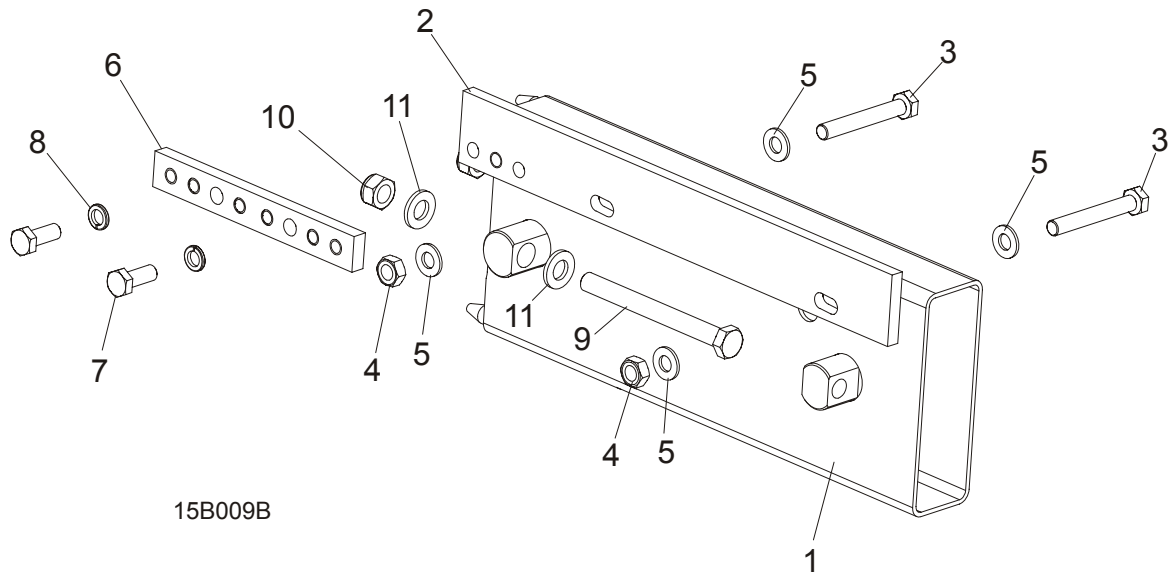

REF	DESCRIPTION (◆ Indicates Parts Available In Assemblies Only)	PART #	QTY.	
	<b>EXTENSION, BED COMPLETE</b>	<b>094251</b>	1	
1	Tube, LT15 GP Bed Extension	094249-1	1	
2	Rail, Bed Extension Track Zinc-plated	094250-1	1	
3	Bolt, M10 x 75-8.8 Hex Head Zinc	F81003-15	2	
4	Nut, M10-8-B Hex Nylon Zinc Lock	F81033-1	2	
5	Washer, 10.5 Flat Zinc	F81055-1	4	
6	Splice, Track Rail Pinned	086659-1	1	
7	Bolt, M10 x 25-8.8 Hex Head Full Thread Zinc	F81003-11	2	
8	Washer, 10.2 Split Lock Zinc	F81055-2	2	
9	Bolt, M12 x 120-8.8 Hex Head Zinc	F81004-38	2	
10	Nut, M12-8 Hex Nylon Zinc Lock	F81034-2	2	
11	Washer, 13 Flat Zinc	F81056-1	4	

**2** **BED FRAME**  
*"M" Type Frame Bed Section*

**2.9 "M" Type Frame Bed Section**

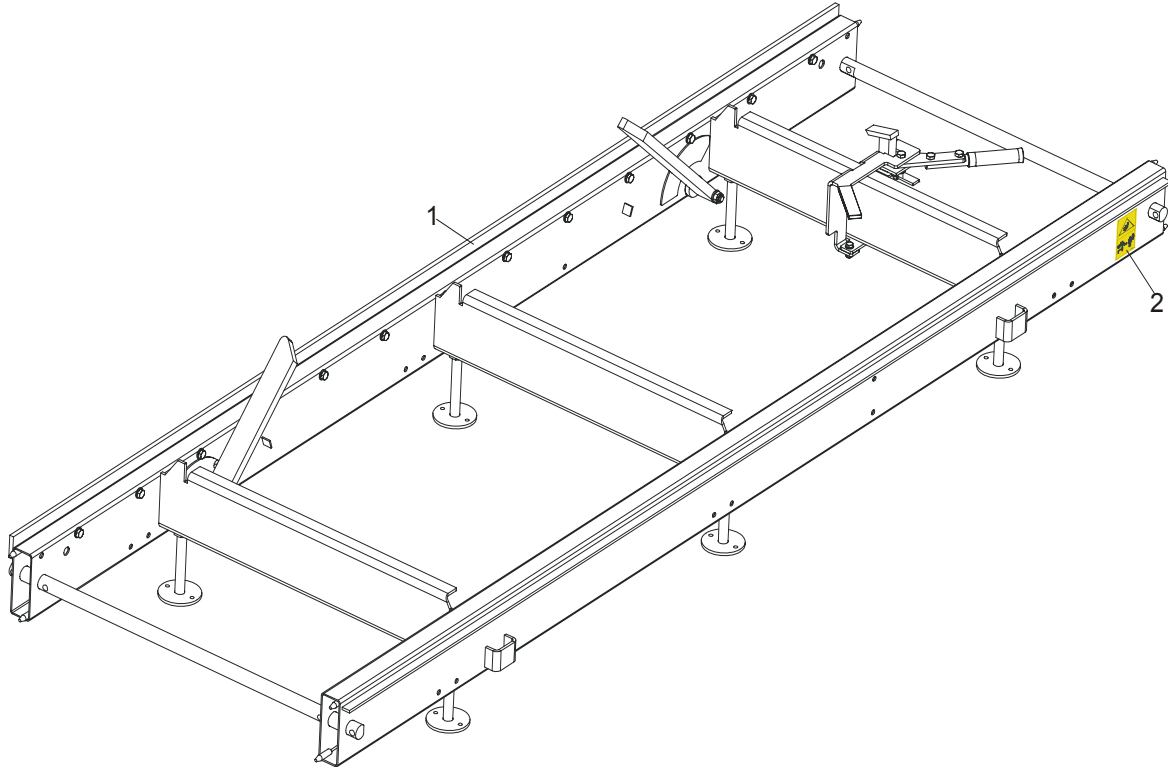

REF	DESCRIPTION (◆ Indicates Parts Available In Assemblies Only)	PART #	QTY.	
	<b>LT15 BED SECTION ASSEMBLY - LONG</b>	<b>094697</b>		
1	Bar, LT15 2700 Track, Zinc-plated	094696-1	1	
2	DECAL, KEEP AWAY DANGER, PICTOGRAM	099221	1	

## 2.10 "S" Type Frame Bed Section

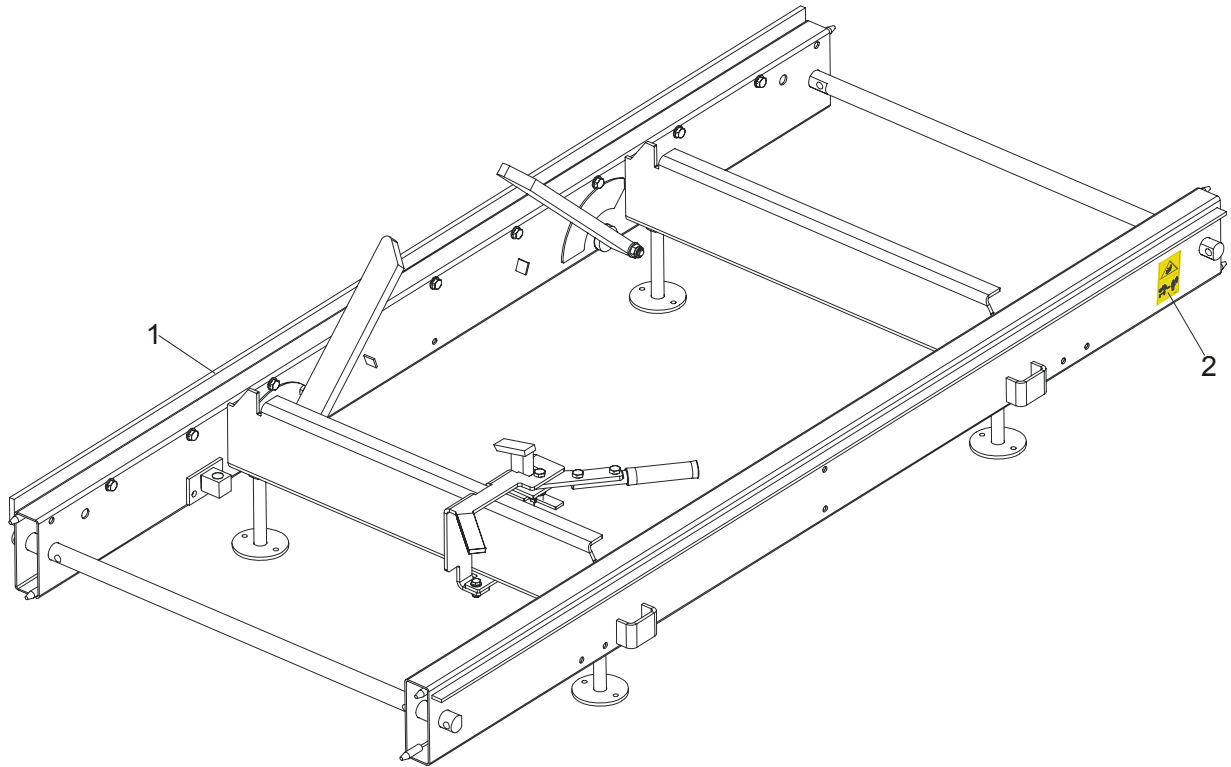

REF	DESCRIPTION (◆ Indicates Parts Available In Assemblies Only)	PART #	QTY.	
	<b>LT15 BED SECTION ASSEMBLY - SHORT</b>	<b>094514</b>		
1	Bar, LT15 1950 Track, Zinc-plated	094427-1	1	
2	DECAL, KEEP AWAY DANGER, PICTOGRAM	099221	1	

## 2 BED FRAME

*Additional Bed Frame Section with Stationary Legs*

### 2.11 Additional Bed Frame Section with Stationary Legs

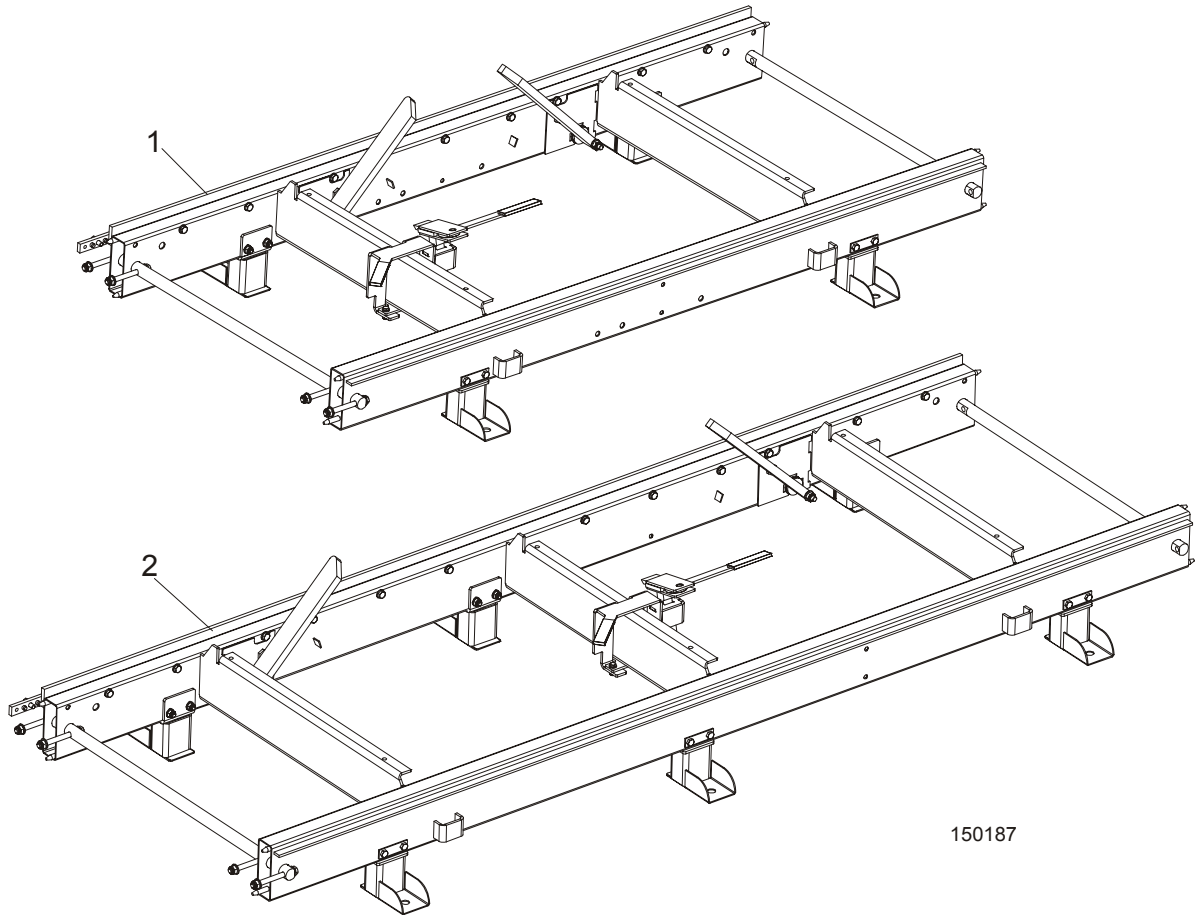

REF	DESCRIPTION (◆ Indicates Parts Available In Assemblies Only)	PART #	QTY.	
1	BED SECTION, LT15 1950 W/STATIONARY LEGS	100341-S	1	
2	BED SECTION, LT15 2700 W/STATIONARY LEGS	100342-S	1	

**2.12 Additional Bed Frame Section with Outrigger Legs**

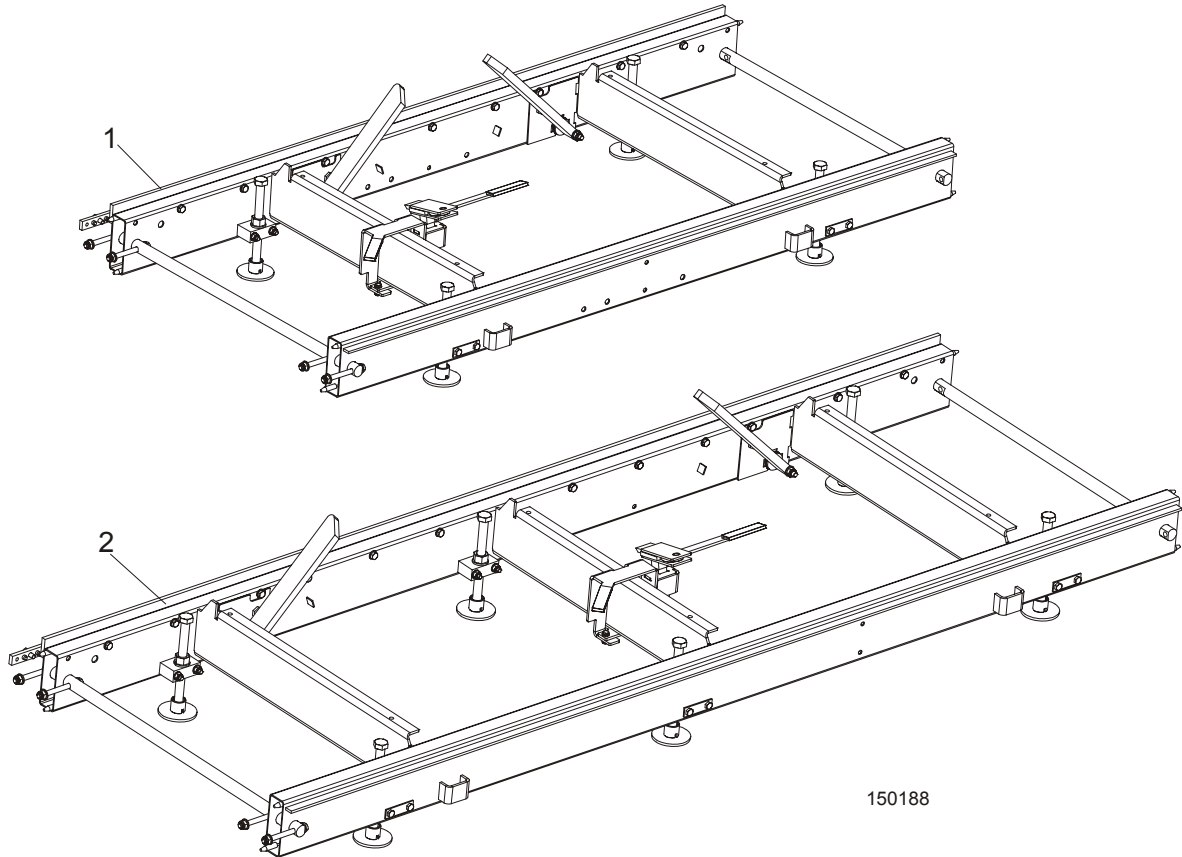

150188

REF	DESCRIPTION (◆ Indicates Parts Available In Assemblies Only)	PART #	QTY.	
1	BED SECTION, LT15 1950 W/OUTRIGGER LEGS	095082-S	1	
2	BED SECTION, LT15 2700 W/OUTRIGGER LEGS	095083-S	1	

**SECTION 3 BLADE GUIDE ROLLERS & ARM**

**3.1 Blade Guide Assembly, Idle Side**

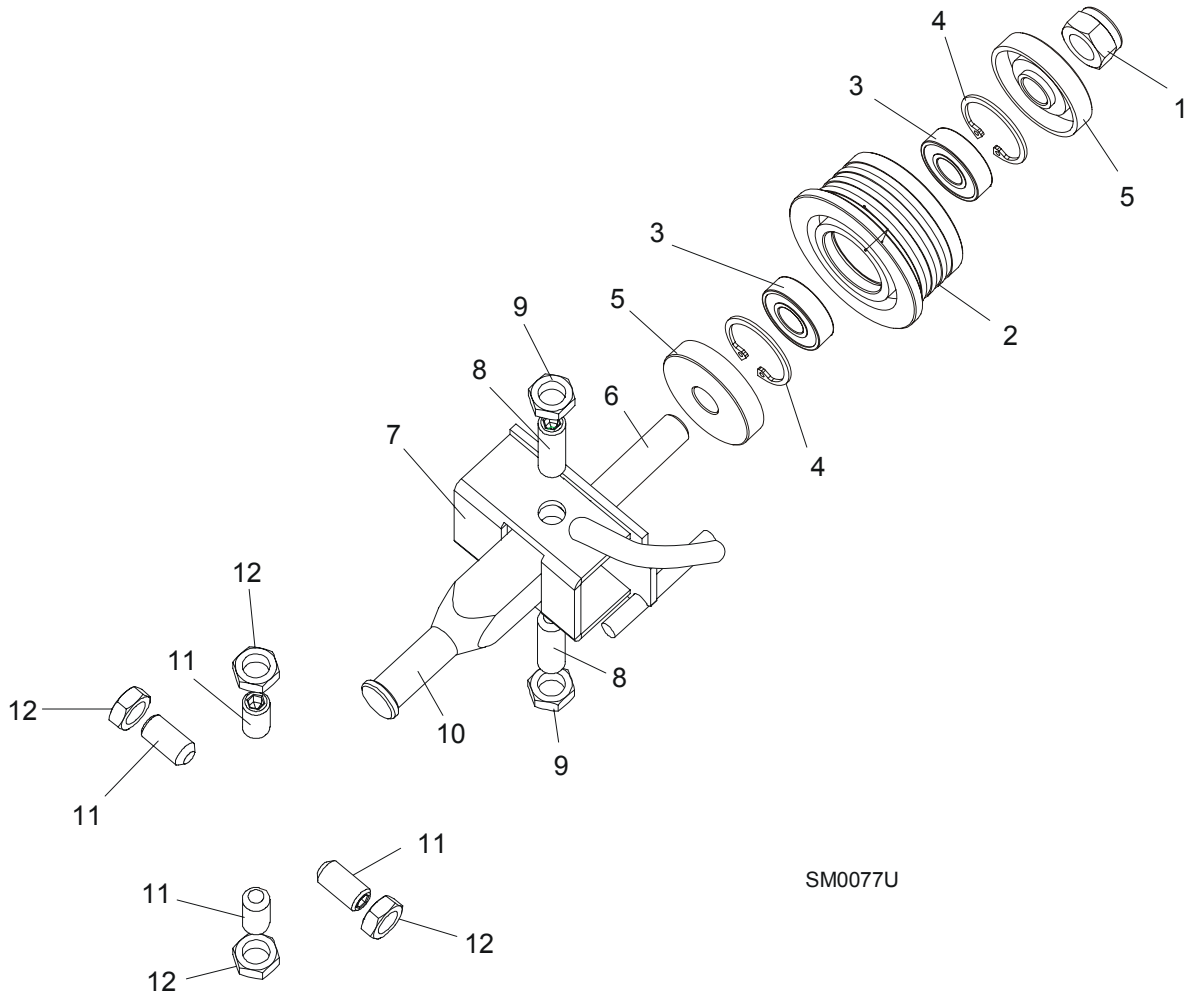

SM0077U

REF	DESCRIPTION (◆ Indicates Parts Available In Assemblies Only)	PART #	QTY.	
	<b>BLADE GUIDE ASSEMBLY, IDLE SIDE</b>	094683	1	
	Roller, Blade Guide Complete Standard	087887	1	
1	Nut, M12-8 Hex Nylon Zinc Lock	F81034-2	1	
2	Roller, Blade Guide Narrow	087889	1	◆
3	Bearing, 6001 2RSR FAG	087893	2	
4	Ring, W28 Inside Retaining	F81090-9	1	
5	Washer, Zinc-plated Spacer	087891-1	2	
6	Shaft, Blade Guide Roller Zinc-plated	087763-1	1	
7	Bracket Weldment, Idle Side Blade Guide Painted	094681-1	1	
8	Screw, M10x1x40 DIN 913 A2-70 Set Stainless Steel	F81015-2	2	



## BLADE GUIDE ROLLERS & ARM

*Blade Guide Assembly, Idle Side*

3

9	Nut, M10x1-04-ST-A2 ISO 8675 Thin	F81033-10	2	
10	Shaft, Zinc-plated Blade Guide Mount	088255-1	1	
11	<b>SCREW, M10X1X20 DIN 913 SET STAINLESS STEEL</b>	F81015-1	4	
12	<b>NUT, M10x1-04-ST-A2 ISO 8675 THIN</b>	F81033-10	4	

**3.2 Blade Guide Assembly, Drive Side**

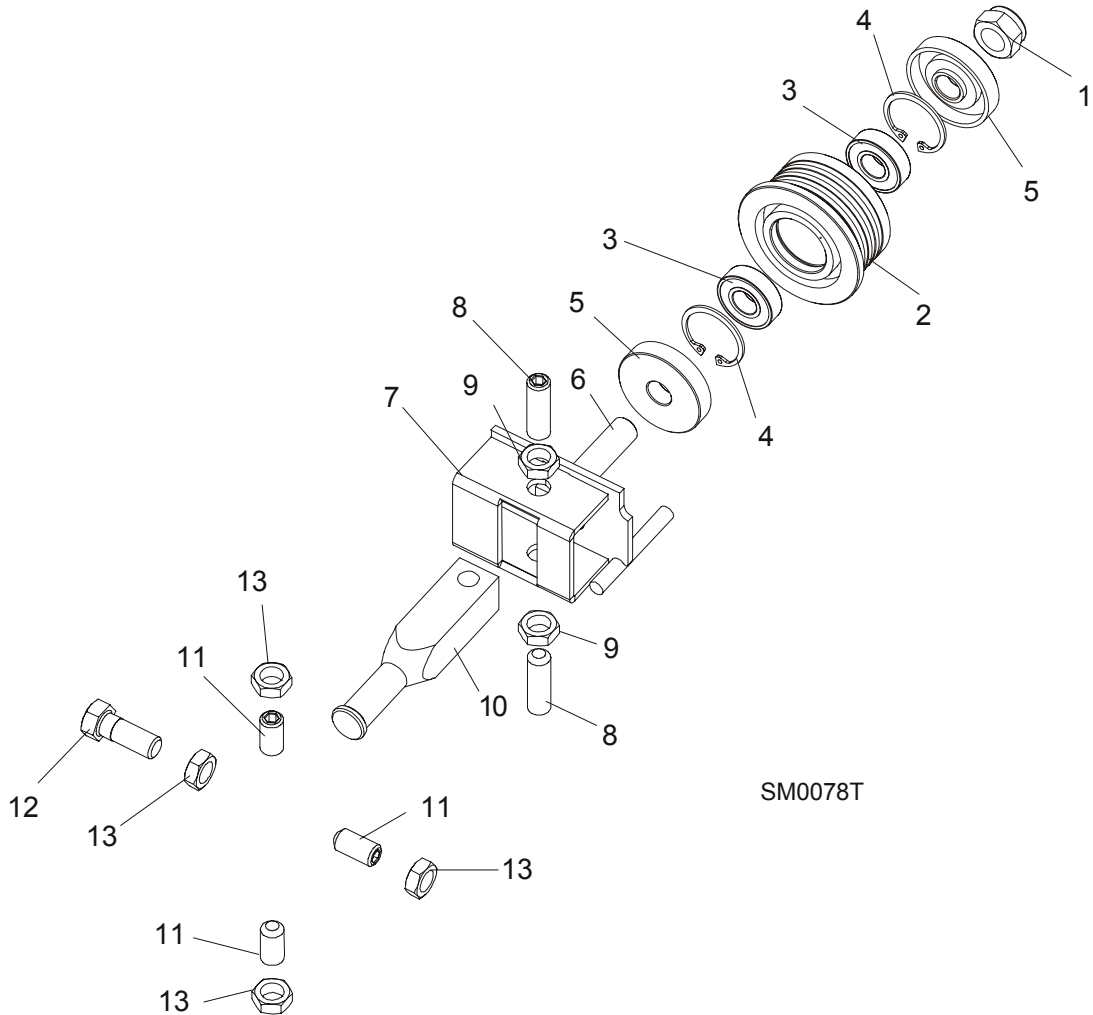

REF	DESCRIPTION (◆ Indicates Parts Available In Assemblies Only)	PART #	QTY.	
	<b>BLADE GUIDE ASSEMBLY, DRIVE SIDE</b>	094682	1	
	Roller, Blade Guide Complete Standard	087887	1	
1	Nut, M12-8 Hex Nylon Zinc Lock	F81034-2	1	
2	Roller, Blade Guide Narrow	087889	1	◆
3	Bearing, 6001 2RSR FAG	087893	2	
4	Ring, W28 Inside Retaining	F81090-9	1	
5	Washer, Zinc-plated Spacer	087891-1	2	
6	Shaft, Blade Guide Roller Zinc-plated	087763-1	1	
7	Bracket Weldment, Blade Guide Painted	094679-1	1	
	Screw Kit, Blade Guide Adjustment w/Nuts (for two blade guide assemblies)	K09942	1	
8	Screw, M10x1x40 DIN 913 A2-70 Set Stainless Steel	F81015-2	2	
9	Nut, M10x1-04-ST-A2 ISO 8675 Thin	F81033-10	2	

## BLADE GUIDE ROLLERS & ARM

*Blade Guide Assembly, Drive Side*

3

10	Shaft, Zinc-plated Blade Guide Mount	088255-1	1	
11	<b>SCREW, M10X1X20 DIN 913 SET STAINLESS STEEL</b>	F81015-1	3	
12	<b>BOLT, M10X1X25 DIN 933 STAINLESS STEEL</b>	F81003-28	1	
13	<b>NUT, M10x1-04-ST-A2 ISO 8675 THIN</b>	F81033-10	4	

**3.3 Blade Guide Roller Guard**

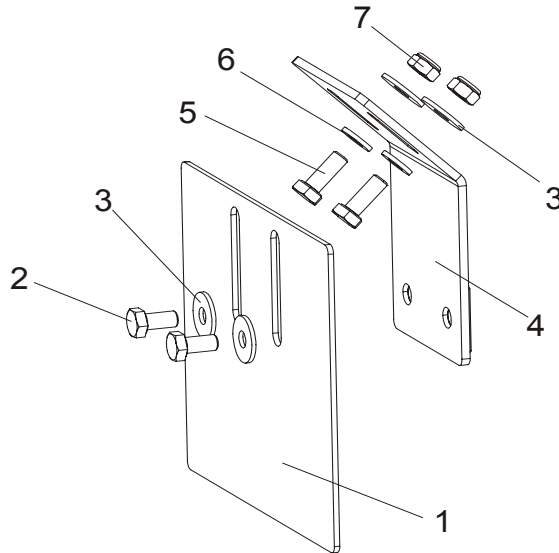

REF	DESCRIPTION (◆ Indicates Parts Available In Assemblies Only)	PART #	QTY.	
1	GUARD, BLADE GUIDE ROLLER PAINTED	092379-1	1	
2	BOLT, M6X12-8.8 HEX HEAD FULL THREAD ZINC	F81001-7	2	
3	WASHER, 6.5 SPECIAL FLAT ZINC	F81053-11	4	
4	BRACKET, ROLLER GUARD MOUNT PAINTED	092378-1	1	
5	BOLT, M6X16 8.8 HEX HEAD FULL THREAD ZINC	F81001-15	2	
6	WASHER, 6.4 FLAT ZINC	F81053-1	2	
7	NUT, M6-8-B HEX NYLON ZINC LOCK	F81031-2	2	

### 3.4 Blade Guide Arm Assembly

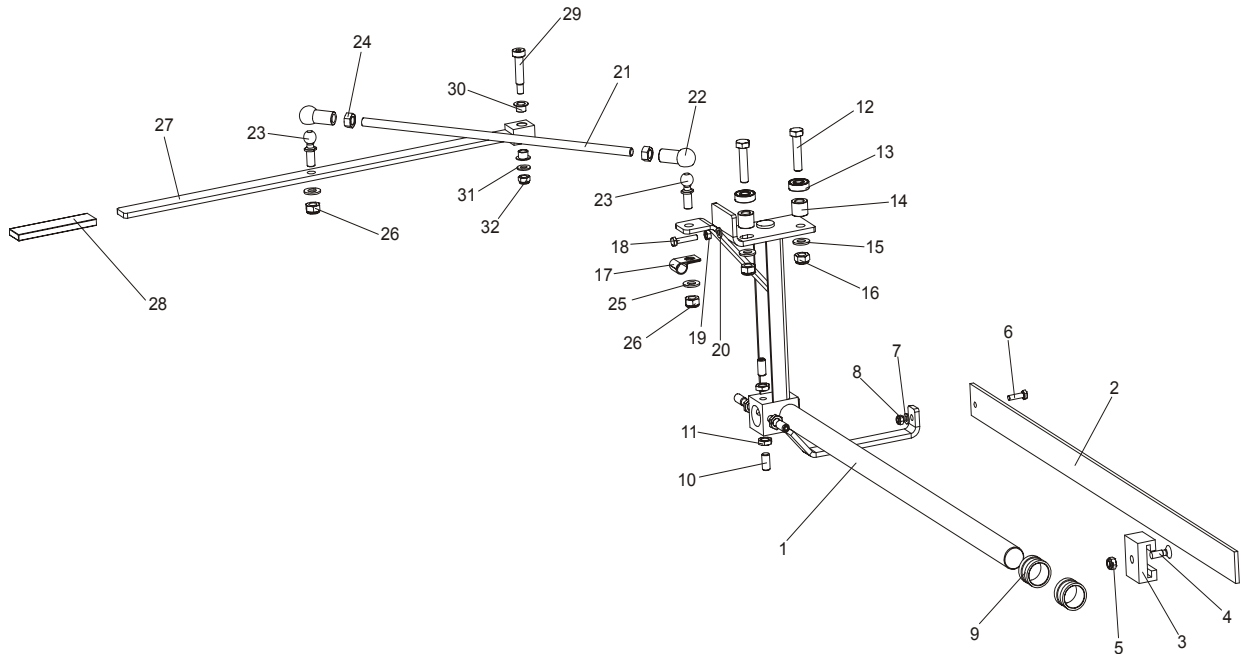

REF	DESCRIPTION (◆ Indicates Parts Available In Assemblies Only)	PART #	QTY.
	<b>BLADE GUIDE ARM W/LEVER - COMPLETE</b>	094136	1
1	Arm Weldment, LT15 Blade Guide	086662	1
2	Bar, LT15 Blade Guard	088306	1
3	Guide, Blade Guard	088305	1
4	Screw, M8x25 Cross Recessed Countersunk Head Zinc	F81002-51	1
5	Nut, M8-8-B Hex Nylon Zinc Lock	F81032-2	1
6	Bolt, M6x20-8.8 Hex Head Full Thread Zinc	F81001-2	1
7	Washer, 6.4 Flat Zinc	F81053-1	1
8	Nut, M6-8-B Hex Nylon Zinc Lock	F81031-2	1
9	Bushing, LT15 Blade Guide	086684	1
10	Screw, M10x1x20 DIN913 Set Stainless Steel	F81015-1	4
11	Nut, M10x1-04-ST-A2 ISO 8675 Thin	F81033-10	4
12	Bolt, M10x45-8.8 Hex Head Full Thread Zinc	F81003-3	2
13	Bearing, 6000.2RSR FAG	087471	2
14	Bushing, Zinc-plated Spacer	094255-1	2
15	Washer, 10.5 Flat Zinc	F81055-1	2
16	Nut, M10-8-B Hex Nylon Zinc Lock	F81033-1	2
17	Clamp, 1/2" EMT Coated	P07584	1
18	Bolt, M6x30 5.8 Hex Head Full Thread	F81001-13	1
19	Nut, M6-8 Hex Zinc	F81031-1	1
20	Washer, 6.4 Flat Zinc	F81053-1	1
	Stud Bolt Assembly, Arm Lever Connection	094204	1

**3****BLADE GUIDE ROLLERS & ARM***Blade Guide Arm Assembly*

21	Bolt, Zinc-plated Stud	094203-1	1	
22	Seat, 16 DIN71805-A BN488 Ball	093824	2	
23	Stud, 16/SW-13 DIN71803-C BN486 Ball	093823	2	
24	Nut, M10-8-B Hex Zinc	F81033-3	2	
25	Washer, 10.5 Flat Zinc	F81055-1	2	
26	Nut, M10-8-B Hex Nylon Zinc Lock	F81033-1	2	
	Lever Assembly, Blade Guide Arm Adjustment	093812	1	
27	Lever, Blade Guide Arm Adjustment Painted	093813-1	1	
28	Cover, RRWA-91626-110 Grip	086875	1	
29	Bolt, 10/M8x35 12.9 ISO7379 Shoulder	F81003-63	1	
30	Bushing, XFM-1012-09	093822	2	
31	Washer, 8.4 Flat Zinc	F81054-1	1	
32	Nut, M8-8-B Hex Nylon Zinc Lock	F81032-2	1	

## SECTION 4 BLADE WHEELS & TENSIONER

### 4.1 Blade Wheel Assembly, Drive Side

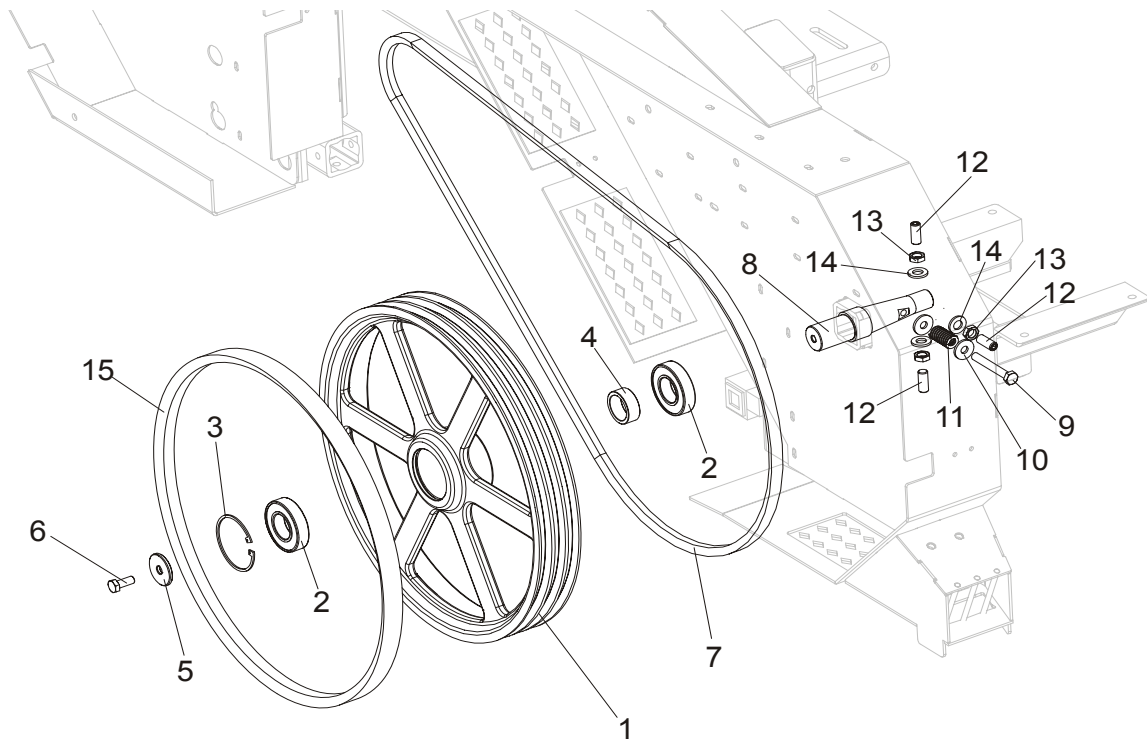

REF	DESCRIPTION (◆ Indicates Parts Available In Assemblies Only)	PART #	QTY.
	<b>BLADE WHEEL ASSEMBLY, LT15 DRIVE SIDE</b>	093849	1
1	WHEEL, LT15 DRIVE SIDE BLADE	014727 <sup>1</sup>	1
2	BEARING, 6207-2RS 35X72X17 FAG	014811 <sup>2</sup>	2
3	RING, 72MM N5002-281 RETAINING	F04254-30	1
4	BUSHING, LT15 BEARING SPACER	093851	1
5	WASHER, LT15 DRIVE SIDE BLADE WHEEL	086286	1
6	BOLT, M10X25-8.8 HEX HEAD FULL THREAD ZINC	F81003-11	1
7	V-BELT, BX81, LT15	<b>014819</b>	1 <sup>3</sup>
8	SHAFT, LT15 DRIVE SIDE BLADE WHEEL	093850	1
9	BOLT, M10X75-8.8 HEX HEAD ZINC	F81003-15	1
10	WASHER, 10.5 SPECIAL FLAT ZINC	F81055-6	2
11	SPRING, 19X38 COMPRESSION	034430	1
12	SCREW, M12X1,25X30 DIN913 SET STAINLESS STEEL	F81016-1	3
13	NUT, M12X1.25 DIN439 THIN STAINLESS STEEL	F81034-9	3
14	WASHER, 13 FLAT ZINC	F81056-1	3
15	V-BELT, B57	P04185	1

<sup>1</sup> LT15 for Russian market is equipped with drive wheel No. 090646-1

<sup>2</sup> LT15 for Russian market is equipped with one bearing 014811 and one 092005 (wide)

<sup>3</sup> LT15 for Russian market is equipped with two belts.

# 4 Blade Wheels & Tensioner

## Blade Wheel Assembly, Idle Side

### 4.2 Blade Wheel Assembly, Idle Side

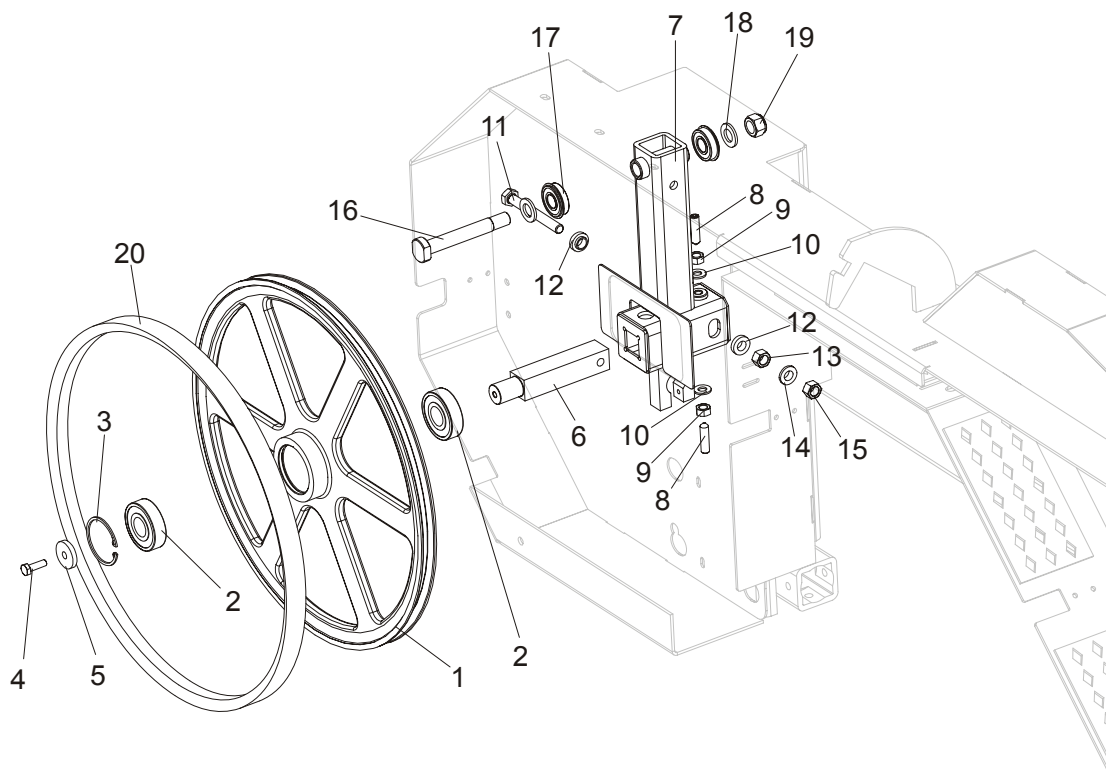

REF	DESCRIPTION (◆ Indicates Parts Available In Assemblies Only)	PART #	QTY.
	<b>WHEEL ASSEMBLY, 19" (482.6MM) BLADE IDLE SIDE</b>	A08218	1
1	WHEEL, 18.62" BLADE IDLE SIDE	P08125	1
2	BEARING, 6305 2RS NSK IDLE SIDE WHEEL	P08066	2
3	RING, 2 7/16" INSIDE RETAINING	F04254-21	1
	<b>HOUSING, LT10 &amp; LT15 IDLER SHAFT, COMPLETE</b>	100180	1
4	BOLT, M8X25-8.8-B HEX HEAD FULL THREAD ZINC	F81002-5	1
5	WASHER, IDLE SIDE WHEEL RETAINING	093854-1	1
6	SHAFT, IDLE SIDE BLADE WHEEL (METRIC)	096045	1
7	HOUSING, IDLER SHAFT	093857-1	1
	HOUSING, LT20 IDLER SHAFT	091595 <sup>1</sup>	1
8	SCREW, M10X40-45H HEX SOCKET SET CONE POINT ZINC	F81003-61	2
9	NUT, M10-8-B HEX ZINC	F81033-3	2
10	WASHER, 10.5 FLAT ZINC	F81055-1	2
11	BOLT, M12X1.25X100-8.8 HEX HEAD FULL THREAD ZINC	F81004-41	1
12	WASHER, FLANGED ZINC-PLATED	086769-1	2
13	NUT, M12X1.25-8 HEX ZINC	F81034-8	1



14	WASHER, Z12.2 SPLIT LOCK ZINC	F81056-2	1	
15	NUT, M12X1.25 8.8 HEX THIN ZINC	F81034-5	1	
16	<b>BOLT, BEARING MOUNT</b>	086404	1	
17	<b>BEARING, 6203-2RS NR NSK W/SNAP RING</b>	086395	2	
18	<b>WASHER, 17 FLAT ZINC</b>	F81058-1	2	
19	<b>NUT, M16-8 HEX NYLON ZINC LOCK</b>	F81036-2	1	
20	<b>V-BELT, B57</b>	P04185	1	

<sup>1</sup> LT15 for Russian market only, not included in 100180.

# 4

## Blade Wheels & Tensioner

### Blade Tensioner Assembly

#### 4.3 Blade Tensioner Assembly

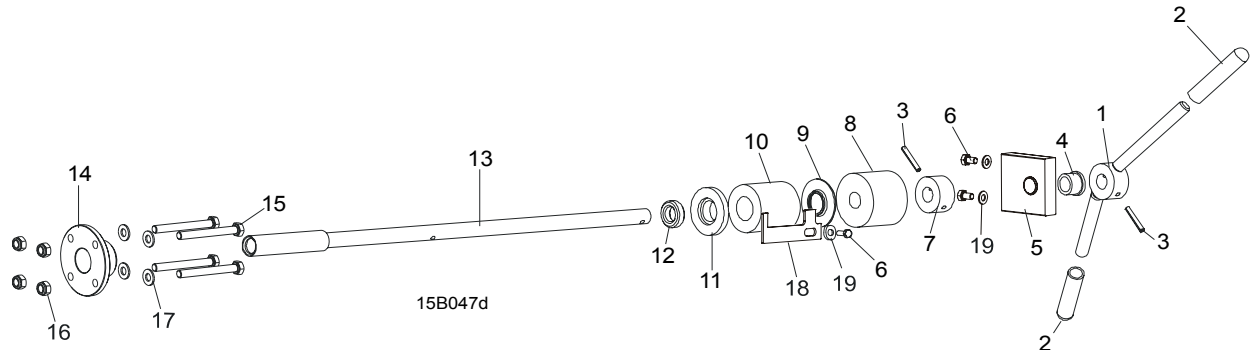

REF	DESCRIPTION (◆ Indicates Parts Available In Assemblies Only)	PART #	QTY.
	<b>LT15 BLADE TENSIONER ASSEMBLY</b>	086680	1
1	Handle, Blade Tension Zinc-plated	086677-1	1
2	Grip, 1/2" I.D. x 3" Blade Tension Handle	014835	2
3	Pin, 5 x 30 Roll Zinc	F81044-21	2
4	Bracket, Tension Handle Mount w/Bushing	096729	1
5	Bushing GFM-1618-17(IGUS)	089589	1
6	Bolt, M6x16 8.8 Hex Head Full Thread Zinc	F81001-15	3
7	Collar, Blade Tensioner Retaining	086712-1	1
8	Bushing, Rubber Stop	P12165	1
9	Guide, LT15 Tension Handle	014925	1
10	Spring, Blade Tensioner	014828	1
11	Washer, Rubber Spring Front	086674-1	1
12	Bearing, 51103 FLT Thrust Ball	086675	1
13	Shaft Weldment, Blade Tensioner Zinc-plated	086669-1	1
14	Nut, Blade Tensioner Painted	086672-1	1
15	Bolt, M8x70 8.8 Hex Head Zinc	F81002-71	4
16	Nut, M8-8-B Hex Nylon Zinc Lock	F81032-2	4
17	Washer, 8.4 Flat Zinc	F81054-1	8
18	<b>INDICATOR, LT15/LT20 BLADE TENSION ZINC-PLATED</b>	092467-1	1
19	<b>WASHER, 6.4 FLAT ZINC</b>	F81053-1	5

### 4.4 Motor Assembly

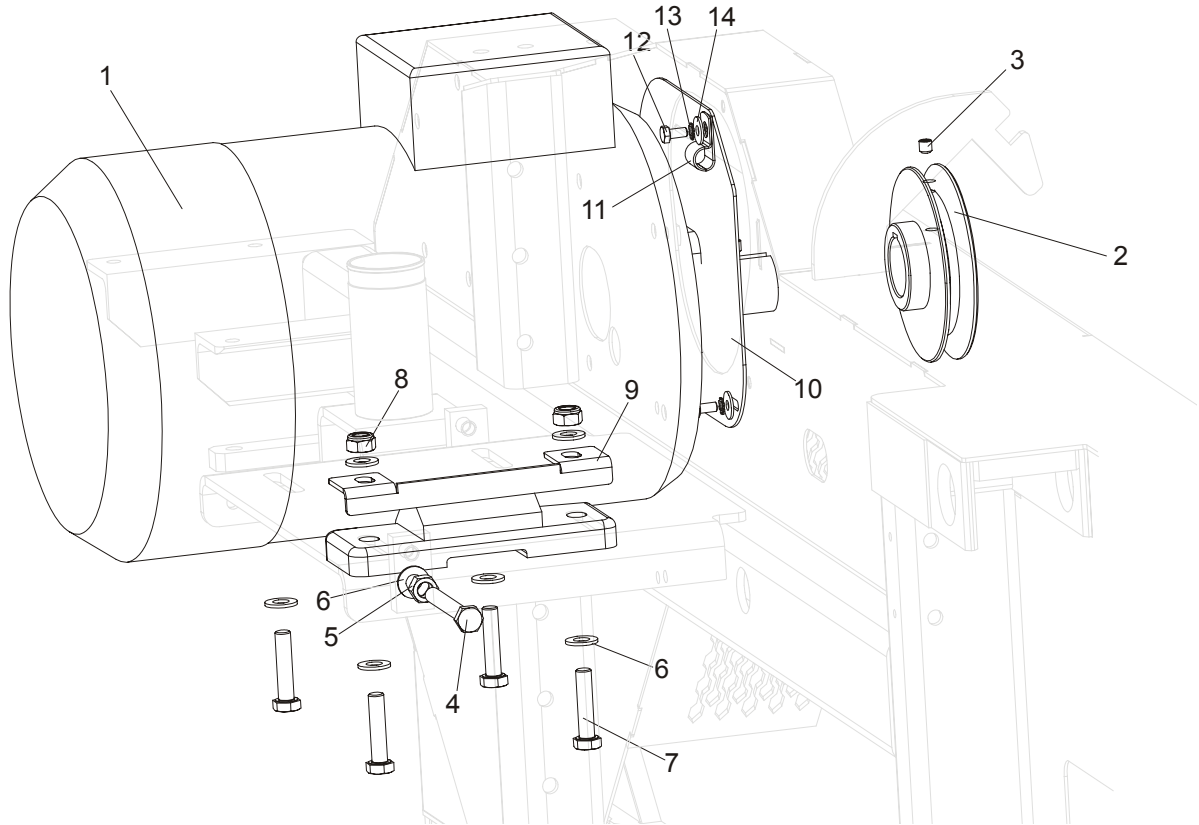

REF	DESCRIPTION (◆ Indicates Parts Available In Assemblies Only)	PART #	QTY.
1	MOTOR, 7.5KW (11HP) 380-420V 50HZ ELECTRIC	085482 <sup>1</sup>	1
2	PULLEY, LT15 E11 MOTOR ZINC-PLATED	086807-1 <sup>2</sup>	1
3	SCREW, M8X8-33H HEX SOCKET SET FLAT POINT ZINC	F81014-1	1
4	BOLT, M10X80-8.8 HEX HEAD FULL THREAD ZINC	F81003-76	2
5	NUT, M10-8-B HEX ZINC	F81033-3	2
6	WASHER, 10.5 FLAT ZINC	F81055-1	10
7	BOLT, M10X45-8.8 HEX HEAD FULL THREAD ZINC	F81003-3	4
8	NUT, M10-8-B HEX NYLON ZINC LOCK	F81033-1	4
9	HANDLE, E11 MOTOR	100760-1	1
10	MOTOR SHAFT COVER, PAINTED, E11, E15	086787	1
11	CLAMP, 1/2" EMT COATED	P07584	1
12	BOLT M6X12-8.8-FE/ZN5	F81001-7	3
13	WASHER, M6, STAR, LOCK, ZINC	F81053-2	3
14	WASHER, 6,5 POW.FE/ZN5 EXT	F81053-11	3

<sup>1</sup> LT15f or Russian market is equipped with motor No. 095005R

<sup>2</sup> LT15 for Russian market is equipped with motor pulley No. 091560-1.

# 4 Blade Wheels & Tensioner

## Power Cord Bracket

### 4.5 Power Cord Bracket

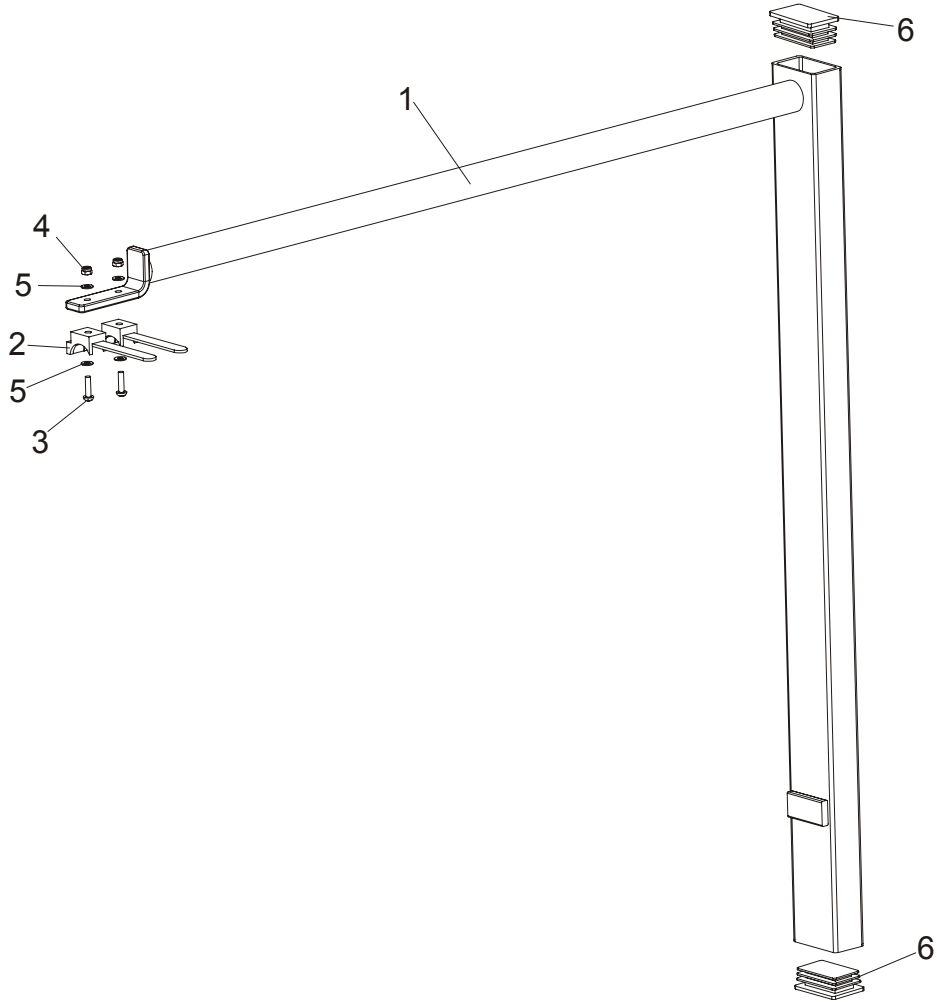

REF	DESCRIPTION (◆ Indicates Parts Available In Assemblies Only)	PART #	QTY.
	<b>BRACKET, LT15 POWER CORD COMPLETE</b>	097449	1
1	Bracket, LT15 Power Cord Painted	086132-1	1
2	Holder, UP30 Cable Plastic Tie	F81082-1	2
3	Screw, M4x16 5.8-B Cross Recessed Pan Head Zinc	F81011-42	2
4	Nut, M4-B Hex Nylon Zinc Lock	F81029-1	2
5	Washer, 4.3 Flat Zinc	F81051-2	4
6	Cap, 50x30 Black	095919	2

## SECTION 5 SAW HEAD

### 5.1 Blade Housing Cover

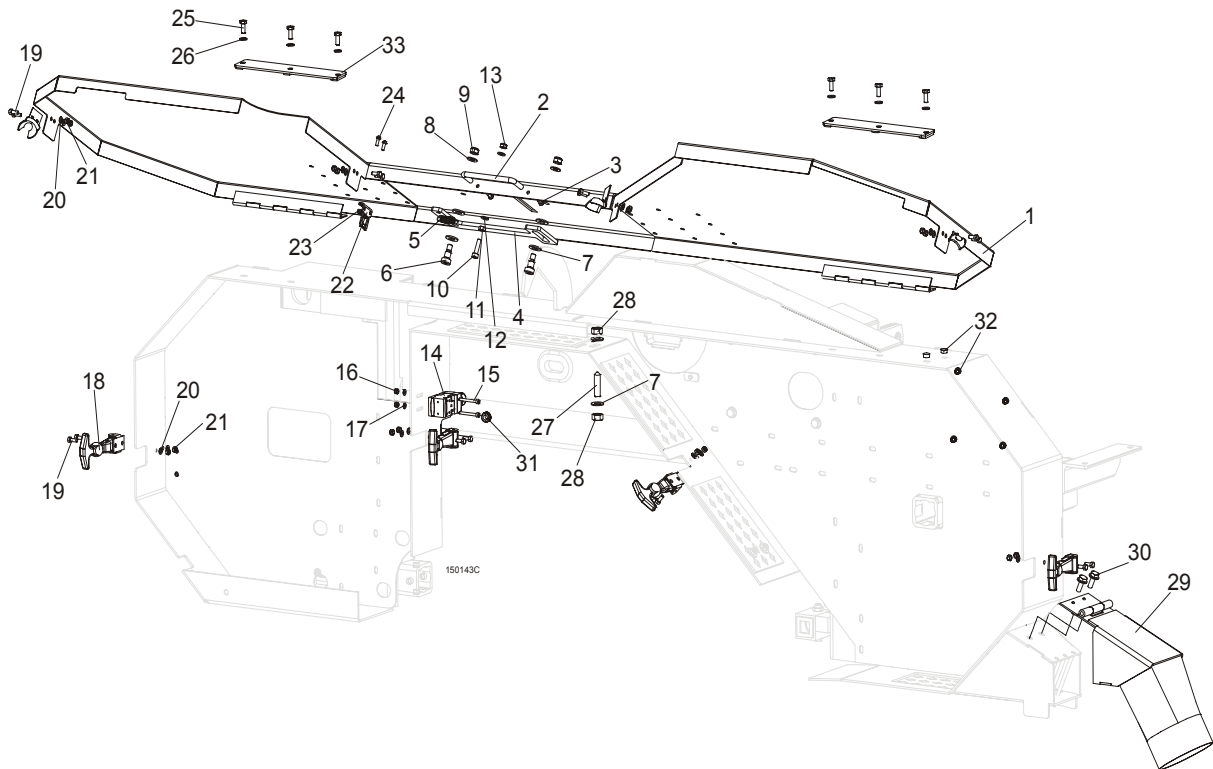

REF	DESCRIPTION (◆ Indicates Parts Available In Assemblies Only)	PART #	QTY.
	<b>COVER, LT15 FRONT COMPLETE</b>	098678	1
1	Cover Weldment, Blade Housing Painted	098679-1	1
2	Handle w/Bolt	P08065	1
3	Screw, #8-32x3/8 Self-tapping	F05015-8	2
4	Pawl, Locking Painted	090643-1	1
5	Spring, 1.6x12x38 Extension	092208	1
6	Bolt, 10/M8x12-12.9 ISO-7379 Shoulder	F81003-62	2
7	Washer, 10.5 Flat Zinc	F81055-1	4
8	Washer, 8.4 Flat Zinc	F81054-1	2
9	Nut, M8-8-B Hex Nylon Zinc Lock	F81032-2	2
10	Screw, M6x25-8.8 Hex Socket Head Cap Zinc	F81001-41	1
11	Nut, M6-8 Hex Zinc	F81031-1	1
12	Washer, 6.4 Flat Zinc	F81053-1	2
13	Nut, M6-8-B Hex Nylon Zinc Lock	F81031-2	1
14	<b>SWITCH, AZ17-11ZRK SAFETY</b>	094232	1
15	<b>SCREW, M4X35-8.8 HEX SOCKET HEAD CAP ZINC</b>	F81011-34	2
16	<b>NUT, M4-B HEX NYLON ZINC LOCK</b>	F81029-1	2

## 5

**Saw Head***Blade Housing Cover*

17	WASHER, 4.3 FLAT ZINC	F81051-2	2	
18	LATCH, FLEXIBLE DRAW	014829	4	
19	BOLT, M5X12-5.8 HEX HEAD FULL THREAD ZINC	F81000-5	8	
20	WASHER, 5.3 FLAT ZINC	F81052-1	8	
21	NUT, M5-8 DIN 985 ZINC-PLATED	F81030-2	8	
22	KEY, A217/170-B5 SAFETY SWITCH	094422	1	
23	NUT, M4-B HEX NYLON ZINC LOCK	F81029-1	2	
24	SCREW, M4X12-5.8-B CROSS RECESSED PAN HEAD ZINC	F81011-43	2	
25	BOLT, M6X16 8.8 HEX HEAD FULL THREAD ZINC	F81001-15	6	
26	WASHER, 6.4 FLAT ZINC	F81053-1	6	
27	SCREW, M10X40-45H HEX SOCKET SET CONE POINT ZINC	F81003-61	1	
28	NUT, M10-8-B HEX ZINC	F81033-3	2	
29	CHUTE, SAWDUST	092460-1	1	
30	BOLT, M8X16-8.8-B HEX HEAD FULL THREAD ZINC	F81002-20	2	
31	GROMMET, 22mm DIA. RUBBER	087400	1	
32	PLUG, SR1086-9,5	096846	6	
33	PLATE, COVER MOUNT	086701-1	2	

## 5.2 Water Lube Assembly

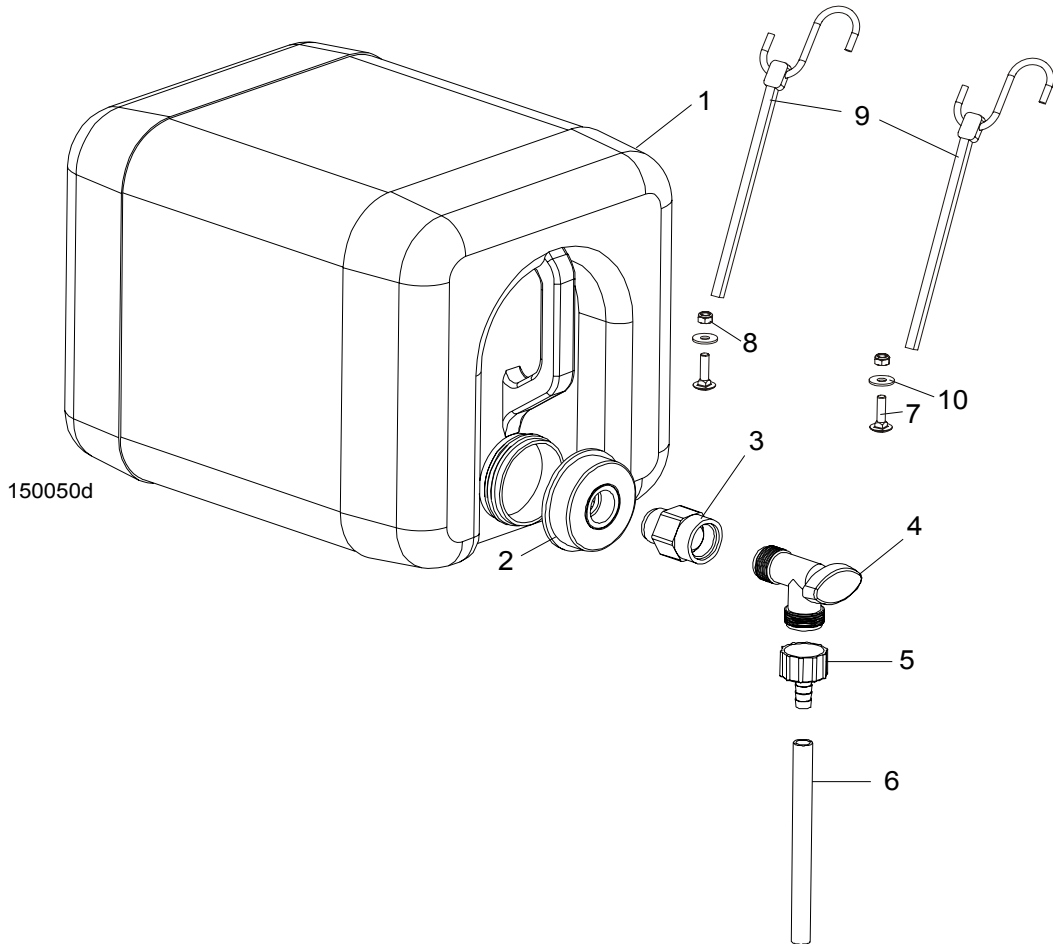

REF	DESCRIPTION (◆ Indicates Parts Available In Assemblies Only)	PART #	QTY.
1	Bottle, 5-gallon Water	014637	1
2	Cap, Water Lube Bottle	014773	1
3	Fitting, 3/4FPT x 3/4MPT Reducer	014636	1
4	Fitting, Water Lube Shutoff Valve	014100	1
5	Fitting, 5/8" NPT to 3/8" Hose Barb	014113	1
6	Tube, 3/8" I.D. Water Lube	R01885	1,7 m
7	Bolt, M6x25-8.8 Mushroom Head Square Neck Zinc	F81001-20	2
8	Nut, M6-8-B Hex Nylon Zinc Lock	F81031-2	2
9	Strap, 24" Rubber w/Hook	P11258	2
10	Washer, 6.5 Special Flat Zinc	F81053-11	2

### 5.3 LT15AC Saw Head Decals

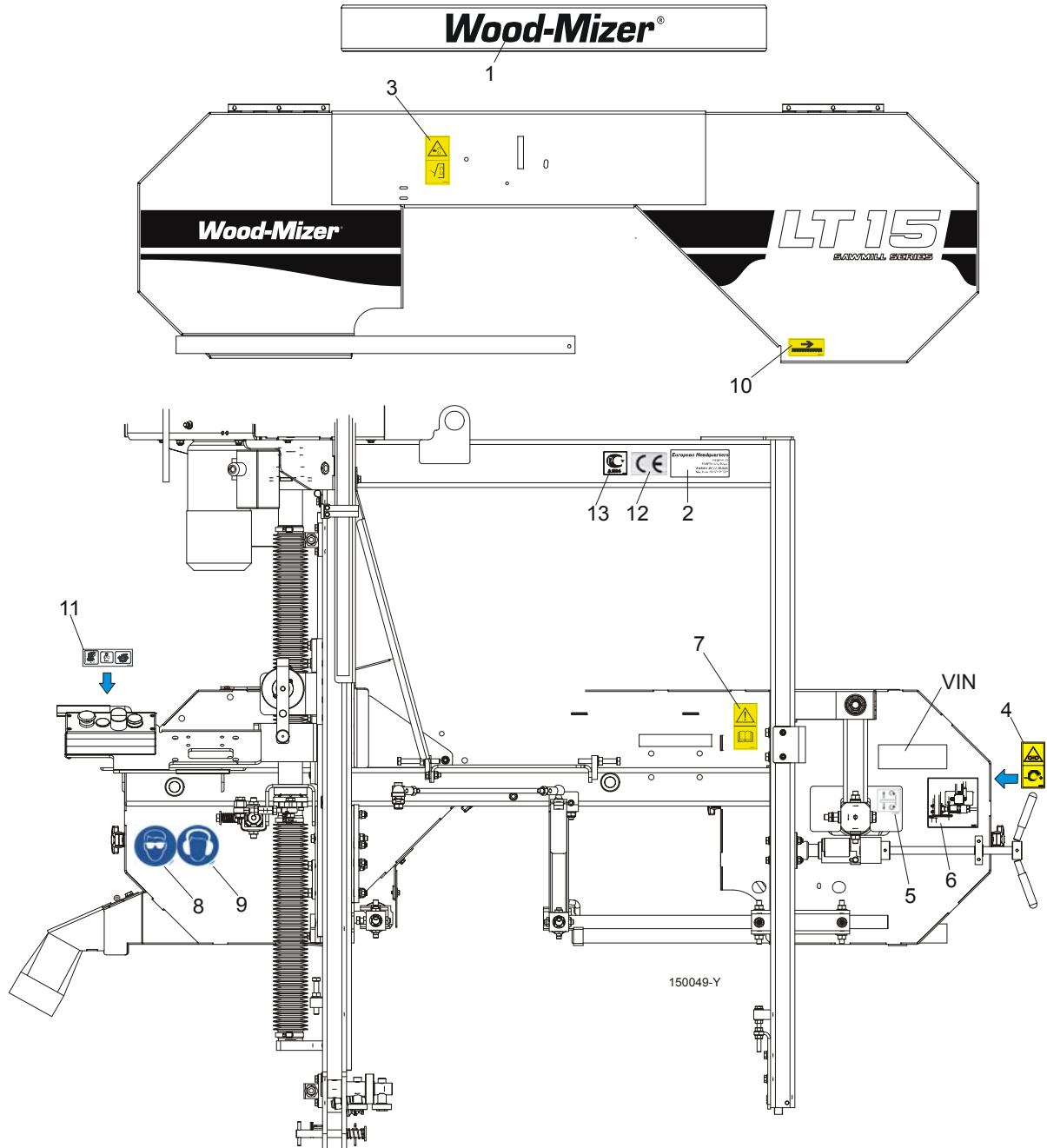

REF	DESCRIPTION (◆ Indicates Parts Available In Assemblies Only)	PART #	QTY.
	<b>PICTOGRAPHIC DECAL KIT, LT15AC</b>	099420	1
	Decal, LT15 Series sawmill	092761	1
1	DECAL, WOOD-MIZER	S12281	1
2	DECAL, EUROPEAN HEADQUARTERS ADDRESS	015841	1
3	DECAL, SAWMILL COVERS CAUTION	099220	1



4	DECAL, BLADE TENSION (PICTOGRAM)	099219	1	
5	DECAL, BLADE ALIGNMENT	P11789	1	
6	DECAL, BLADE TENSION INDICATOR ADJUSTMENT	092597	1	
7	DECAL, READ OPERATOR'S MANUAL (PICTOGRAM)	096317	1	
8	DECAL, EYE PROTECTION WARNING (PICTOGRAM)	S12004G	1	
9	DECAL, EAR PROTECTION WARNING (PICTOGRAM)	S12005G	1	
10	DECAL, BLADE MOVEMENT DIRECTION (PICTOGRAM)	096321	1	
11	DECAL KIT, LT15AC CONTROL BOX	100582	1	
12	<b>DECAL, CE CERTIFIED SAWMILL (SMALL)</b>	P85070	1	
13	<b>DECAL, RUSSIAN SAFETY CERTIFICATION</b>	099401	1	

### 5.4 Control Box

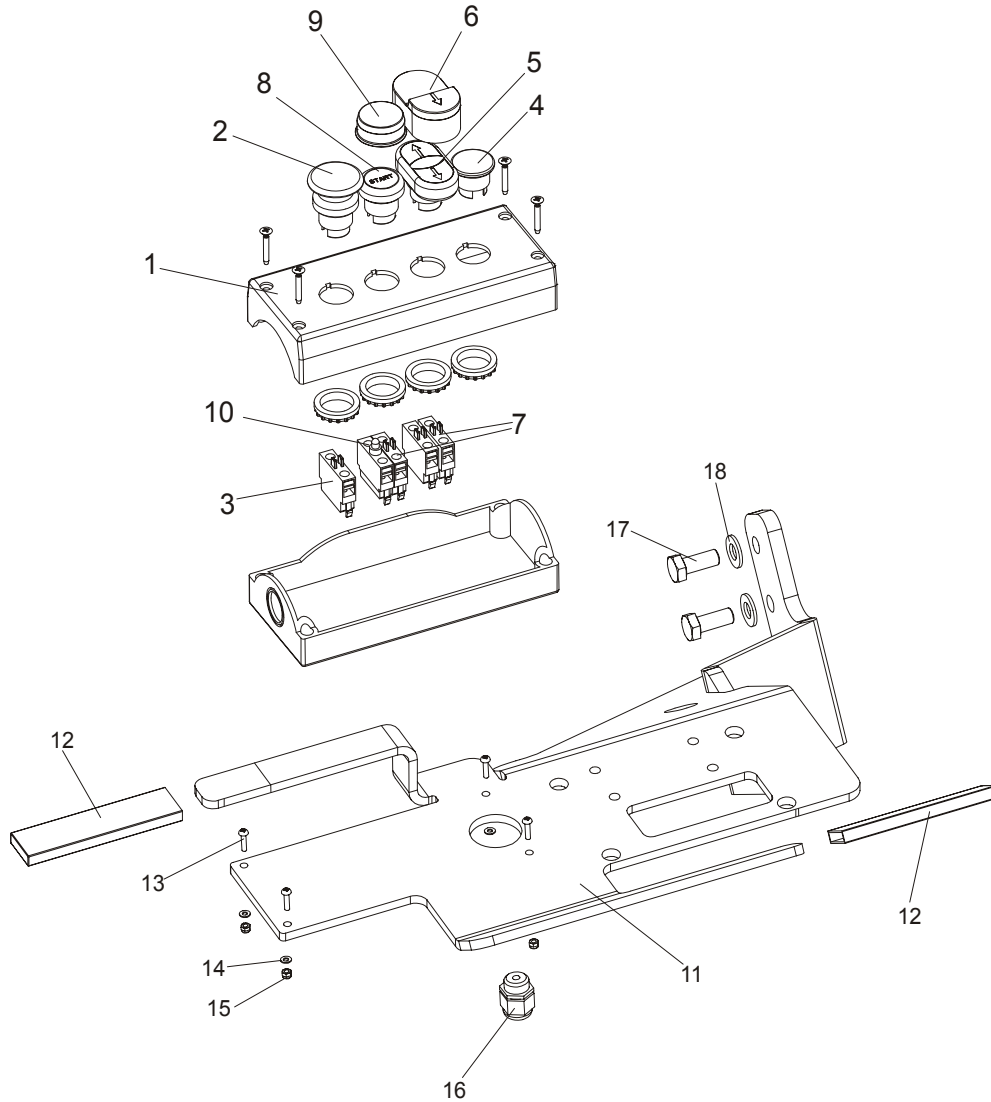

REF	DESCRIPTION (◆ Indicates Parts Available In Assemblies Only)	PART #	QTY.
	<b>CONTROL BOX, LT15 AC COMPLETE W/ MOUNT BRACKET</b>	094195	1
	Control Box, LT15 Complete	094258	1
1	Body, Control Box	094259	1
2	Button, M22 Momentary Mushroom Red	094328	1
3	Element, M22-KC10 Contact	094314	1
4	Cap, M22-B ( 216388)	093748	1
5	Button, M22-DD-S-X7/X7	090917	1
6	Boot, M22-T-DD	090462	1
7	Element, M22-KC10 1 Contact	094314	2
8	Button, Green Illuminated START	094315	1
9	Boot	094316	1
10	Element, LED M22-LEDC-G	099921	1

11	Bracket, Control Box Mount Painted	094233-1	1	
12	Cover, RRWA-91626-110 Grip	086875	2	
13	Screw, M4x16 5.8-B Cross Recessed Pan Head Zinc	F81011-42	4	
14	Washer, 4.3 Flat Zinc	F81051-2	4	
15	Nut, M4-B Hex Nylon Zinc Lock	F81029-1	2	
16	Gland, DP 13/H Cable	F81096-4	1	
17	Washer, 10.5 Flat Zinc	F81055-1	2	
18	Bolt, M10x25-8.8 Hex Head Full Thread Zinc	F81003-11	2	

## 5.5 Electric Box

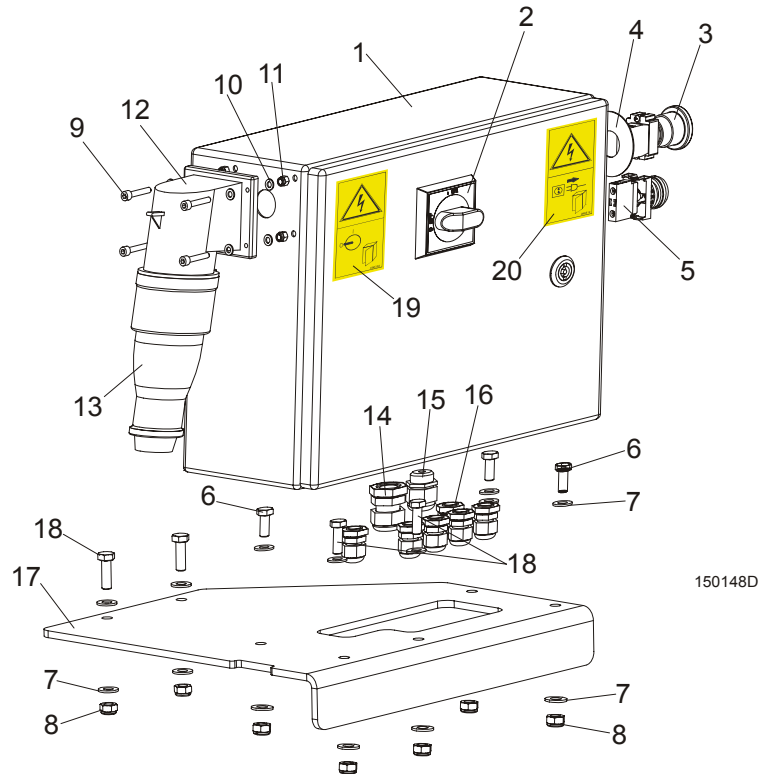

REF	DESCRIPTION (◆ Indicates Parts Available In Assemblies Only)	PART #	QTY.
1	<b>ELECTRIC BOX, LT15AC</b>	094237	1
2	Knob, OHB2AJ ABB Selector Switch	088265-1	1
3	Button, XB4 BS542 Emergency Stop	086556	1
4	Washer, ZBY9330 E-Stop Button	086561	1
5	Light, M22 LED 24V White Control	090448	1
6	Bolt, M8x20-8.8-B Hex Head Full Thread Zinc	F81002-4	3
7	Washer, 8.4 Flat Zinc	F81054-1	14
8	Nut, M8-8-B Hex Nylon Zinc Lock	F81032-2	7
9	Bolt, M5x20-8.8 Hex Socket Head Cap Zinc	F81000-72	4
10	Washer, 5.3 Flat Zinc	F81052-1	4
11	Nut, M5-8 Hex Nylon Zinc Lock	F81030-2	4
12	Plug, 16A 5P 2607 BALS	E85239	1
13	Socket, 16A 400V IP57 31243 BALS	E85240	1
14	Grommet, DP 16/H	F81096-7	1
15	Grommet, DP 13/H	F81096-4	1
16	Grommet, DP 9/H	F81096-2	6
17	<b>PLATE, LT15 ELECTRIC BOX</b>	098677-1	1
18	<b>BOLT, M8 X 25-8.8-B HEX HEAD FULL THREAD ZINC</b>	F81002-5	4
19	<b>DECAL, HIGH VOLTAGE INSIDE THE ELECTRIC BOX (PICTOGRAM)</b>	096316	1
20	<b>DECAL, REMOVE THE PLUG BEFORE OPENING THE BOX (PICTOGRAM)</b>	096319	1

## SECTION 6 FEED SYSTEM

### 6.1 Feed Crank Assembly

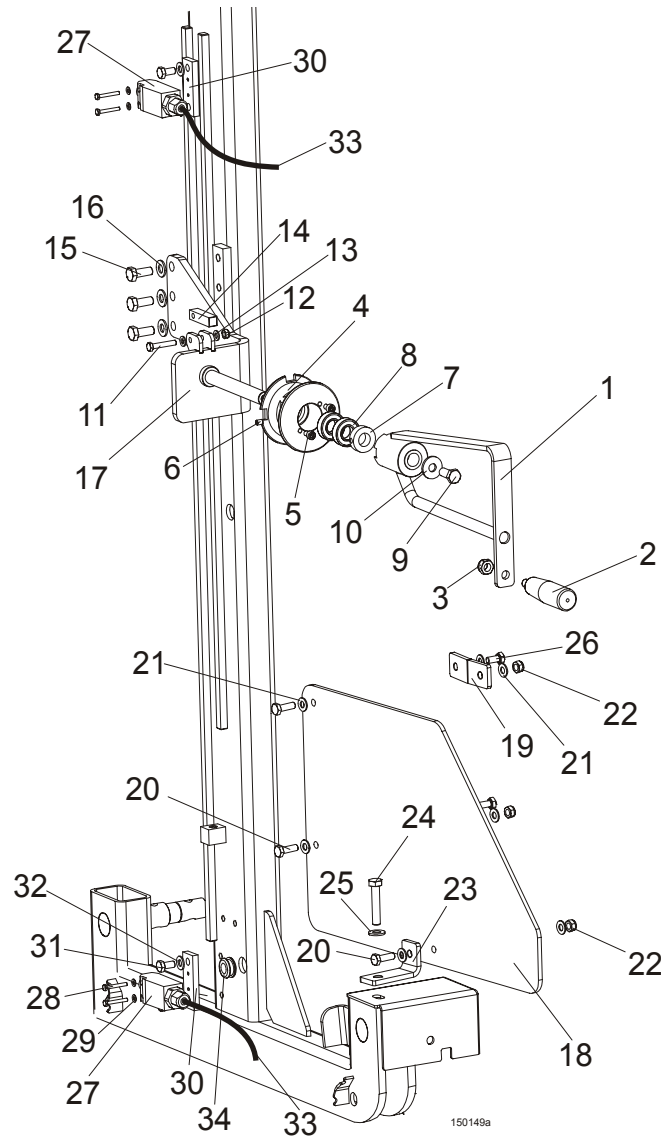

REF	DESCRIPTION (◆ Indicates Parts Available In Assemblies Only)	PART #	QTY.
	<b>MANUAL FEED SYSTEM</b>	094186	1
	Feed Crank Assembly	094260	1
1	Crank Weldment, Feed Painted	094191-1	1
2	Knob, 12992M10 Plastic Crank Handle	086338	1
3	Nut, M10-8-B Hex Nylon Zinc Lock	F81033-1	1
4	Pulley, LT15 Feed Rope	086117	1
5	Screw, M6x10-8.8 Hex Socket Head Cap Zinc	F81001-12	2
6	Screw, M6x8 Hex Socket Set Cone Point Zinc	F81013-1	1

## 6

## Feed System

## Feed Crank Assembly

7	Ring, 17 Stopping Light Type Zinc-plated	F81039-1	1	
8	Bearing, 6003-2RS FAG Rolling	086116	2	
9	Bolt, M10x25-8.8 Hex Head Full Thread Zinc	F81003-11	1	
10	Washer, 10.5 Special Flat Zinc	F81055-6	1	
11	Bolt, M6x35 8.8 Hex Head Zinc	F81001-71	1	
12	Nut, M6-8-B Hex Nylon Zinc Lock	F81031-2	1	
13	Washer, 6.4 Flat Zinc	F81053-1	2	
14	Pawl, LT15 Detent Zinc-plated	086156-1	1	
15	Bolt, M10x25-8.8 Hex Head Full Thread Zinc	F81003-11	3	
16	Washer, 10.5 Flat Zinc	F81055-1	3	
17	Bracket Weldment, Feed Rope Pulley Painted	094187-1	1	
	<b>GUARD, LT15 COMPLETE LOWER</b>	093858	1	
18	Plate, LT15 Lower Guard	093859	1	
19	Bracket, Side Painted	086171-1	2	
20	Bolt, M8x25-8.8-B Hex Head Full Thread Zinc	F81002-5	3	
21	Washer, 8.4 Flat Zinc	F81054-1	6	
22	Nut, M8-8-B Hex Nylon Zinc Lock	F81032-2	3	
23	Bracket, Lower Painted	086172-1	1	
24	<b>BOLT, M10X50-8.8 HEX HEAD FULL THREAD ZINC</b>	F81003-4	1	
25	<b>WASHER, 10.5 FLAT ZINC</b>	F81055-1	1	
26	<b>BOLT, M8X16-8.8-B HEX HEAD FULL THREAD ZINC</b>	F81002-20	1	
	<b>EVN2000C LIMIT SWITCH W/MOUNT PLATE</b>	094227	2	
27	Switch, EVN2000 C Limit	089816	1	
28	Bolt, M4x30 8.8 Hex Head Full Thread Zinc	F81011-5	2	
29	Washer, 4.3 Flat Zinc	F81051-2	2	
30	Plate, Limit Switch Mount Painted	094228-1	1	
31	Bolt, M8x16 -8.8-B Hex Head Full Thread Zinc	F81002-20	2	
32	Washer, 8.4 Flat Zinc	F81054-1	2	
33	Cable, OLFLEX 400P 2x1	R80583-5	3m	
34	<b>GROMMET, 20/13 RUBBER</b>	086188	1	

## 6.2 Track Rail, Rollers & Travel Pins

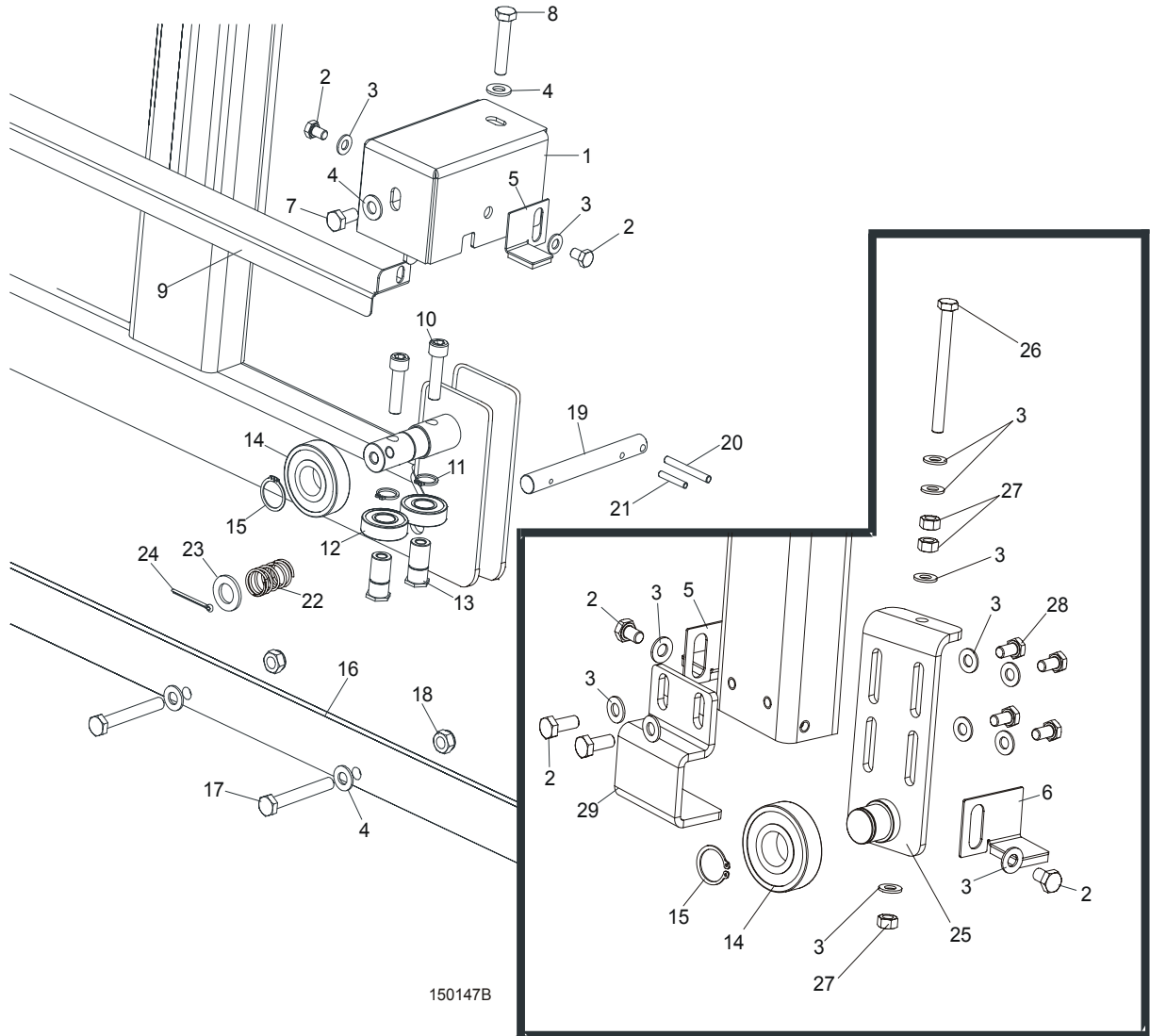

REF	DESCRIPTION (◆ Indicates Parts Available In Assemblies Only)	PART #	QTY.
1	HOUSING, TRACK ROLLER PAINTED	086739-1	2
2	BOLT, M8X12-8.8 HEX HEAD FULL THREAD ZINC	F81002-6	8
3	WASHER, 8.4 FLAT ZINC	F81054-1	16
4	WASHER, 10.5 FLAT ZINC	F81055-1	13
5	PLATE, LT15 RIGHT TRACK WIPER PAINTED	086324-1	2
6	PLATE, LT15 LEFT TRACK WIPER PAINTED	086325-1	2
7	BOLT, M10 X 20 5.8 HEX HEAD FULL THREAD ZINC	F81003-1	2
8	BOLT, M10X50-8.8 HEX HEAD FULL THREAD ZINC	F81003-4	2
9	COVER, MIDDLE TRACK	086745	1

10	SCREW, M10X40 HEX SOCKET HEAD CAP ZINC	F81003-22	4	
11	RING, Z 17 OUTSIDE RETAINING	F81090-21	4	
12	BEARING, 6203-2RS ROLLING	086114	4	
13	SHAFT, SIDE BEARING MOUNT ZINC-PLATED	086645-1	4	
14	BEARING, 6305-2RS CX	085706	3	
15	RING, 25Z OUTSIDE RETAINING	F81090-22	2	
16	RAIL, LT15 1950 (LT15S3) TRACK ZINC-PLATED	094427-1	3	
	RAIL, LT15 2700 (LT15M2) TRACK ZINC-PLATED	094696-1	2	
17	BOLT, M10X75-8.8 HEX HEAD ZINC	F81003-15	9/13 <sup>1</sup>	
18	NUT, M10-8-B HEX NYLON ZINC LOCK	F81033-1	9/13 <sup>2</sup>	
19	PIN, TRAVEL LOCK ZINC-PLATED	086743-1	2	
20	PIN, 6X50 ROLL ZINC	F81045-1	2	
21	PIN, 5 X 30 ROLL ZINC	F81044-21	2	
22	SPRING, 18X37X1.8 COMPRESSION ZINC-PLATED	087301	2	
23	WASHER, 17 FLAT ZINC	F81058-1	2	
24	PIN, 4 X 25 COTTER ZINC	F81043-2	2	
25	BRACKET WELDMENT, IDLE SIDE ROLLER PAINTED	094198-1	1	
26	BOLT, M8X90-8.8 HEX HEAD FULL THREAD ZINC	F81002-16	1	
27	NUT, M8-8-B HEX ZINC	F81032-1	3	
28	BOLT, M8X16-8.8-B HEX HEAD FULL THREAD ZINC	F81002-20	4	
29	GUIDE, LT15 MAST IDLE SIDE PAINTED	086202-1	1	

<sup>1</sup> Number of bolts for one bed section.

<sup>2</sup> Number of nuts for one bed section.



### 6.3 Feed Rope, V-groove Rollers & Brackets

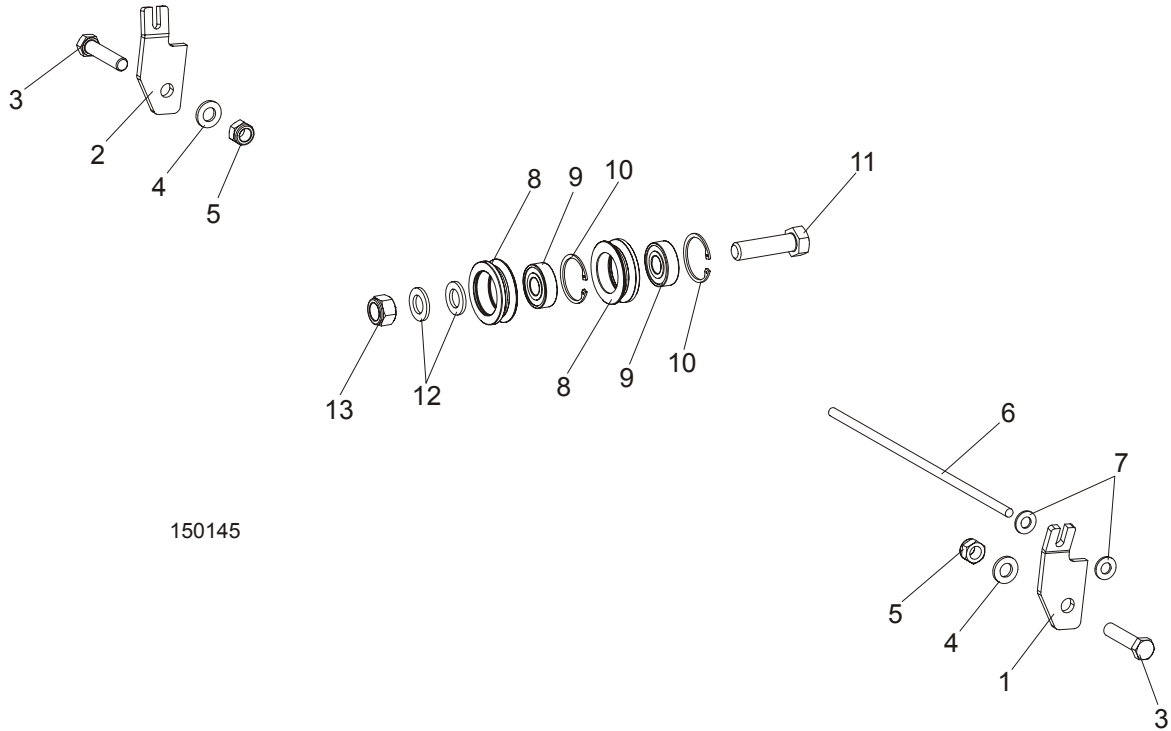

150145

REF	DESCRIPTION (◆ Indicates Parts Available In Assemblies Only)	PART #	QTY.
1	BRACKET, LT15 ROPE MOUNT FRONT PAINTED	092569-1	1
2	BRACKET, LT15 ROPE MOUNT REAR PAINTED	092570-1	1
3	BOLT, M12X55-8.8 HEX HEAD ZINC	F81004-12	2
4	WASHER, 13 FLAT ZINC	F81056-1	2
5	NUT, M12-8-B HEX ZINC	F81034-1	2
6	ROPE, 5/16" DIA. BRAIDED POLYESTER	R02080	9,0 m
7	WASHER, 10.5 FLAT ZINC	F81055-1	2
	<b>ROLLER ASSEMBLY, V-GROOVE W/BEARING</b>	093855	2
8	Roller, V-groove Zinc-plated	093856-1	1
9	Bearing, 6203 2RS 5/8 CX	095087	1
10	Ring, W40 Inside Retaining	F81090-3	1
11	BOLT, M16X60 8.8 HEX HEAD FULL THREAD ZINC	F81006-12	1
12	WASHER, 17 FLAT ZINC	F81058-1	2
13	NUT, M16-8 HEX NYLON ZINC LOCK	F81036-2	1

## SECTION 7 UP/DOWN SYSTEM

### 7.1 AC Up/Down Drive Assembly

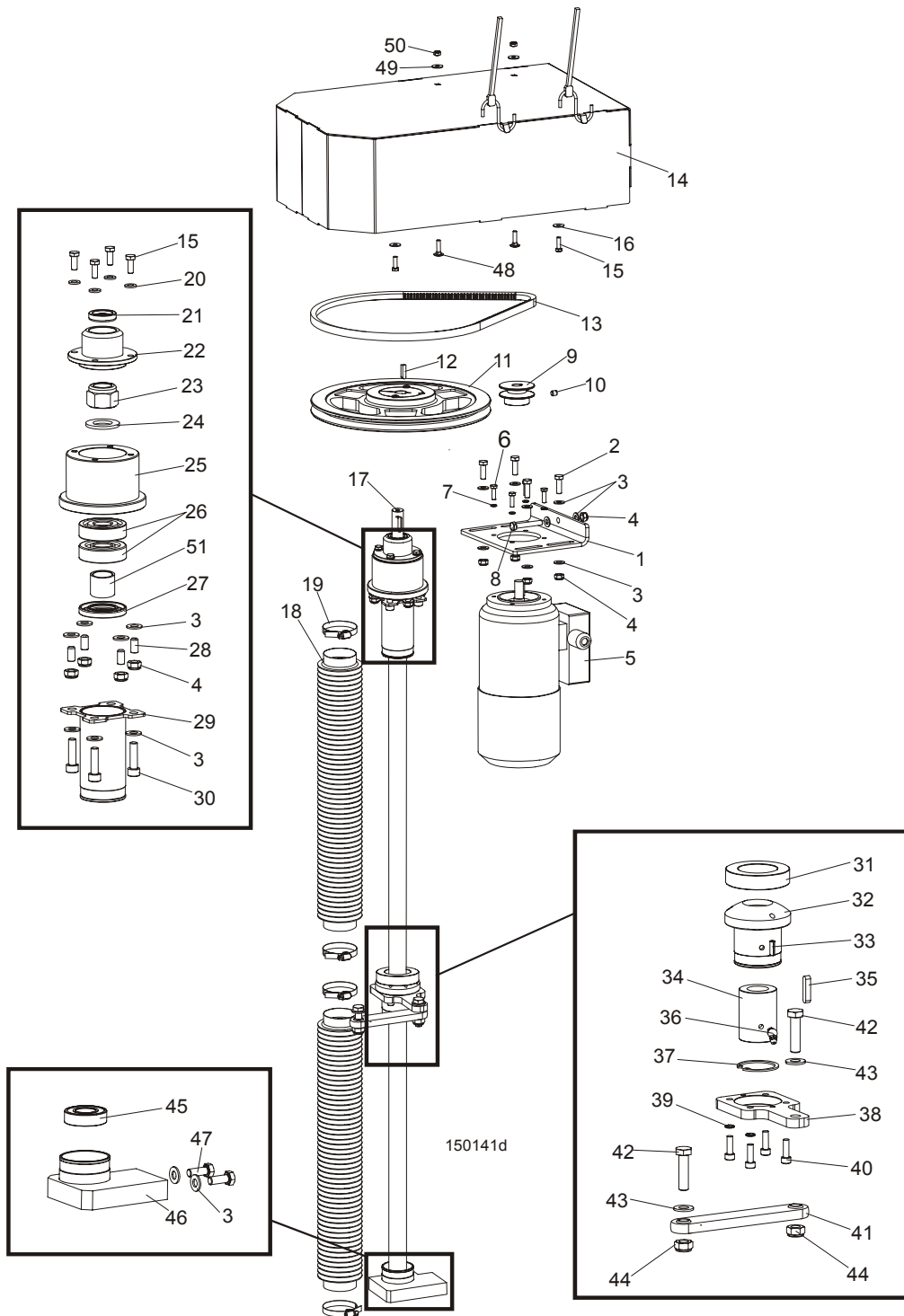

REF	DESCRIPTION (◆ Indicates Parts Available In Assemblies Only)	PART #	QTY.
	<b>UP/DOWN DRIVE - AC, COMPLETE</b>	094143	1
1	Plate, Drive Belt Tension	094162-1	1
2	Bolt, M8x25-8.8-B Hex Head Full Thread Zinc	F81002-5	4
3	Washer, 8.4 Flat Zinc	F81054-1	22
4	Nut, M8-8-B Hex Nylon Zinc Lock	F81032-2	9
5	Motor, AC Up\Down Drive	094161	1
6	Bolt, M6x20-8.8 Hex Head Full Thread Zinc	F81001-2	4
7	Washer, Z 6.1 Split Lock Zinc	F81053-3	4
8	Bolt, M8x50-8.8 Hex Head Full Thread Zinc	F81002-19	1
9	Pulley, Up/Down Motor	094160-1	1
10	Screw, M8x8-33H Hex Socket Set Flat Point Zinc	F81014-1	1
11	Pulley, SPA 280/1 w/18 Split Taper Bushing	094157	1
12	Key, AB 6x6x23 Parallel	089191	1
13	V-belt, AVX-13x1100 La	095306	1
14	Cover, Up/Down System LT15 Complete High	096948	1
	Strap, 24 in rubber with hooks	P11258	2
15	Bolt, M6x20-8.8 Hex Head Full Thread Zinc	F81001-2	8
16	Washer, 6.4 Flat Zinc	F81053-1	4
17	Screw, Tr 28x5 Acme	094144	1
18	Bellows, 50/700 Protective	094208	2
19	Clamp, 40-60mm	F81095-4	4
20	Washer, 6.4 Flat Zinc	F81053-1	4
21	Ring, A018x30x7 Sealing	094159	1
22	Cover, Up/Down Bearing Housing	094165-1	1
23	Nut, M20x1.5-8-A2 ISO10512 Self-locking	F81037-5	1
24	Washer, 21 Flat Zinc	F81059-2	1
25	Housing, Up/Down Bearings	094164-1	1
26	Bearing, 7304B -UO CX	094256	2
27	Ring, A28x52x7 Sealing	094155	1
28	Screw, M8x16-33H Hex Socket Set Flat Point	F81014-2	4
29	Bracket, Upper Bellows Mount Zinc-plated	094221-1	2
30	Screw, M8x30-8.8 Hex Socket Head Cap Zinc	F81002-31	4
31	Washer, DIN6319-42-C Spherical Seat	F81061-7	1
	Up/Down Nut Assembly	094150	1
32	Housing, TR28x5 Acme Nut Zinc-plated	094241-1	1
33	Pin, 5x16 Roll Zinc	F81044-3	2
34	Nut, Tr 28x5 (PET T) Acme Screw	094243	1
35	Key, A6x6x30 Parallel	094245	1
36	Fitting, M6 "B" Type PN-M/86003 Grease	094213	1
37	Ring, W40 Inside Retaining	F81090-3	1
38	Plate, Nut Housing Seat	094242-1	1
39	Washer, Z 6.1 Split Lock Zinc	F81053-3	4
40	Screw, M6x20-8.8 Hex Socket Head Cap Zinc	F81001-22	4
41	Link, SBPL 10104 Pivotal	097700	1
42	Bolt, M10x40-8.8 Hex Head Full Thread Zinc	F81003-16	2

**7****Up/Down System***AC Up/Down Drive Assembly*

---

<b>43</b>	Washer, 10.5 Flat Zinc	F81055-1	2	
<b>44</b>	Nut, M10-8-B Hex Nylon Zinc Lock	F81033-1	2	
<b>45</b>	Bearing, 6004 2RS-CX Rolling	093868	1	
<b>46</b>	Seat, Lower Bearing	093866-1	1	
<b>47</b>	Bolt, M8x20-8.8-B Hex Head Full Thread Zinc	F81002-4	2	
<b>48</b>	Bolt, M6x25-8.8 Mushroom Head Square Neck Zinc	F81001-20	2	
<b>49</b>	Washer, 6.5 Special Flat Zinc	F81053-11	2	
<b>50</b>	Nut, M6-8-B Hex Nylon Zinc Lock	F81031-2	2	
<b>51</b>	Spacer, LT15 Drive Bearing	094156-1	1	

## 7.2 Slide Pads & Blade Height Scale Indicator

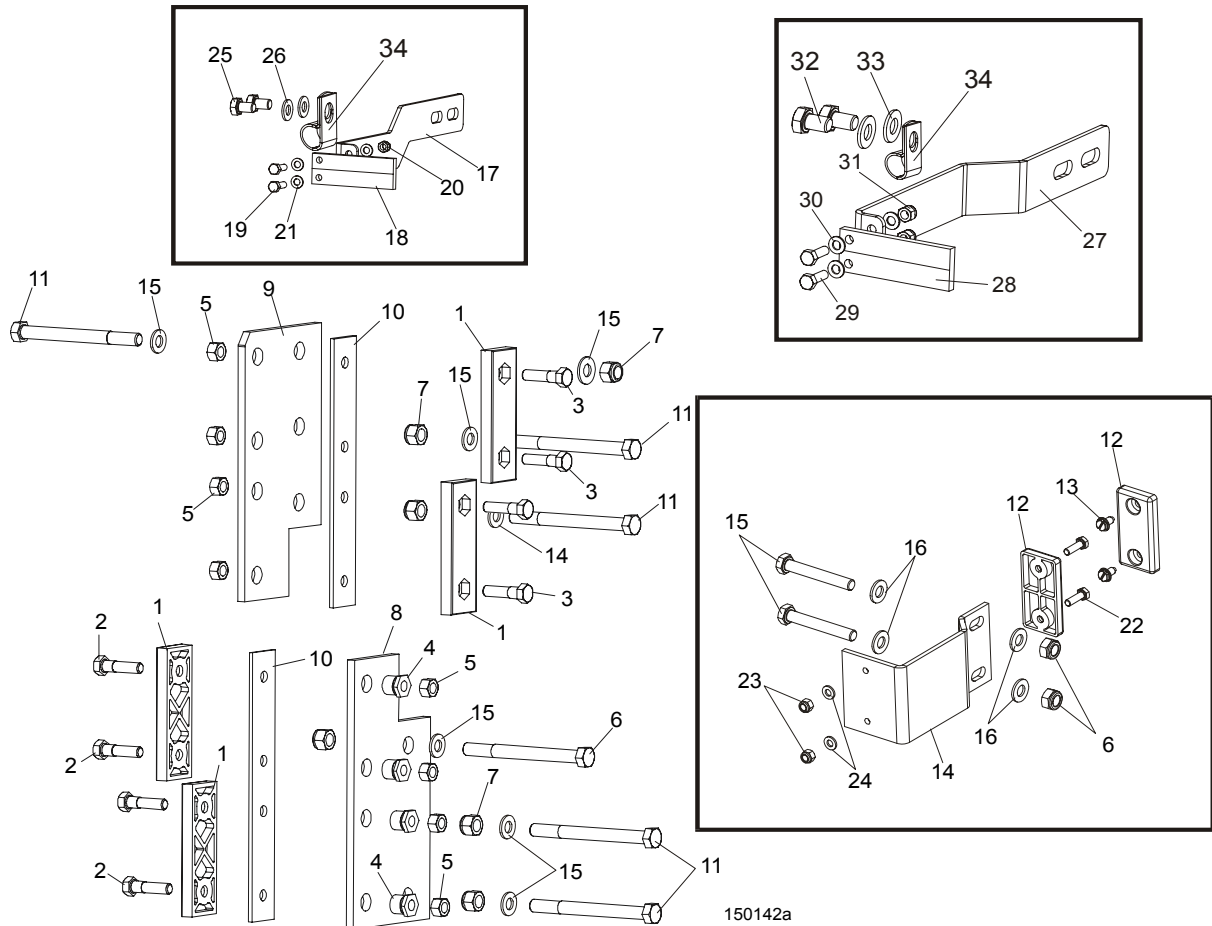

REF	DESCRIPTION (◆ Indicates Parts Available In Assemblies Only)	PART #	QTY.
1	PADS, DELRIN UP/DOWN SLIDE	M04096	4
2	BOLT, M8X35-8.8 HEX HEAD FULL THREAD ZINC	F81002-13	4
3	BOLT, M8X20-8.8 HEX HEAD FULL THREAD ZINC	F81002-4	4
4	NUT, LT15 SLIDE PAD ADJUSTMENT	086683-1	4
5	NUT, M8-8-B HEX NYLON ZINC LOCK	F81032-2	8
6	BOLT, M10X110 8.8 HEX HEAD ZINC	F81003-43	1
7	NUT, M10-8-B HEX NYLON ZINC LOCK	F81033-1	8
8	PLATE, SAW HEAD LOWER GUIDE PAINTED	086682-1	1
9	PLATE, SAW HEAD UPPER GUIDE PAINTED	094139-1	1
10	PLATE, SLIDE PAD SPACER PAINTED	094140-1	2
11	BOLT, M10X115-8.8 HEX HEAD ZINC	F81003-19	5
12	PAD, IDLE SIDE SLIDE	P13576	2
13	SCREW, 1/4-20 X 1/2" "23" TYPE SELF-TAPPING	F05015-1	2
14	GUIDE, LT15 SAW HEAD PAINTED	087192-1	1

## 7

**Up/Down System***Slide Pads & Blade Height Scale Indicator*

15	<b>BOLT, M10X70-8.8 HEX HEAD FULL THREAD ZINC</b>	F81003-20	2	
16	<b>WASHER, 10.5 FLAT ZINC</b>	F81055-1	11	
	<b>SCALE INDICATOR (STANDARD)</b>	094226	1	
17	Bracket, Scale Indicator Mount Painted	094224-1	1	
18	Indicator, Blade Height Scale	094821	1	
19	Bolt, M5NX16-8.8 Hex Head Full Thread Zinc	F81000-20	2	
20	Nut, M5-8 DIN 985 Zinc-Plated	F81030-2	2	
21	Washer, 5.3 Flat Zinc	F81052-1	4	
22	<b>BOLT, M6X20-8.8 HEX HEAD FULL THREAD ZINC</b>	F81001-2	2	
23	<b>NUT, M6-8-B HEX NYLON ZINC LOCK</b>	F81031-2	2	
24	<b>WASHER, 6.4 FLAT ZINC</b>	F81053-1	2	
25	<b>BOLT, M8X12-8.8 HEX HEAD FULL THREAD ZINC</b>	F81002-6	2	
26	<b>WASHER, 8.4 FLAT ZINC</b>	F81054-1	2	
	<b>SCALE INDICATOR (OPTIONAL)</b>	<b>095967</b>		
27	Bracket, Scale Indicator Mount Painted	095968-1	1	
28	Indicator, Blade Height Scale	094821	1	
29	Bolt, M5X16-8.8 Hex Head Full Thread Zinc5	F81000-20	2	
30	Washer, 5.3 Flat Zinc	F81052-1	4	
31	Nut, M5-8 DIN 985 Zinc-plated	F81030-2	2	
32	Bolt, M8x12-8.8 Hex Head Full Thread Zinc	F81002-6	2	
33	Washer, 8.4 Flat Zinc	F81054-1	2	
34	<b>CLAMP, 1/2" EMT COATED</b>	P07584	1	

### 7.3 Blade Height Scale & Up/Down Limit Switches

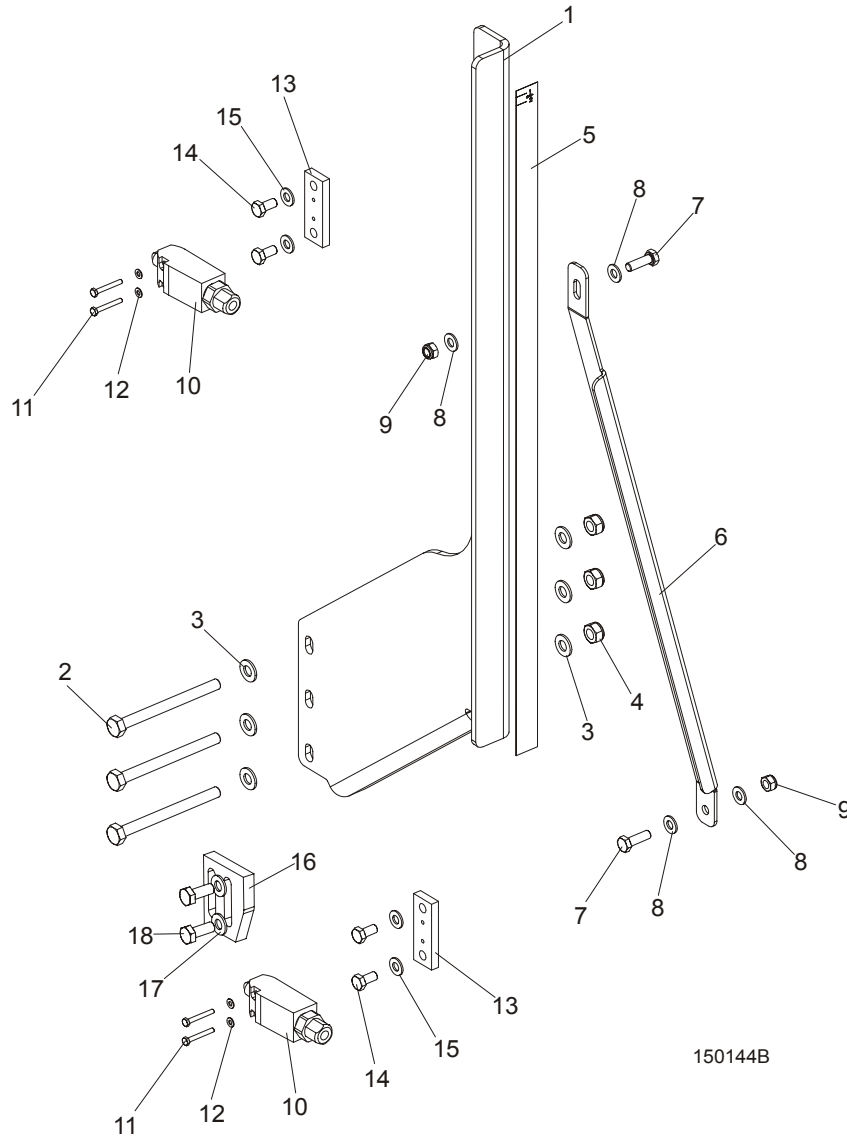

150144B

REF	DESCRIPTION (◆ Indicates Parts Available In Assemblies Only)	PART #	QTY.
	<b>BRACKET, BLADE HEIGHT SCALE, COMPLETE</b>	094225	1
1	Bracket, Blade Height Scale, Painted	094223-1	1
2	Bolt, M10X115-8.8 Hex Head Zinc	F81003-19	3
3	washer, 10.5 flat zinc	F81055-1	6
4	Nut, M10-8-B Hex Nylon Zinc Lock	F81033-1	3
5	Decal, LT15AC Blade Height Metric Scale	094151	1
	Decal, LT15AC Blade Height Inch Scale	096658	1
6	<b>BRACKET, BLADE HEIGHT SCALE MOUNT PAINTED</b>	094257-1	1
7	<b>BOLT, M8X25-8.8-B HEX HEAD FULL THREAD ZINC</b>	F81002-5	2

# 7

## Up/Down System

### *Blade Height Scale & Up/Down Limit Switches*

8	<b>WASHER, 8.4 FLAT ZINC</b>	F81054-1	4	
9	<b>NUT, M8-8-B HEX NYLON ZINC LOCK</b>	F81032-2	2	
	<b>EVN2000C LIMIT SWITCH W/MOUNT PLATE</b>	094227	2	
10	Switch, EVN2000 C Limit	089816	1	
11	Bolt, M4x30 8.8 Hex Head Full Thread Zinc	F81011-5	2	
12	Washer, 4.3 Flat Zinc	F81051-2	2	
13	Plate, Limit Switch Mount	094228-1	1	
14	Bolt, M8x16-8.8-B Hex Head Full Thread Zinc	F81002-20	2	
15	Washer, 10.5 Flat Zinc	F81055-1	2	
16	<b>BRACKET, LIMIT SWITCH</b>	094229-1	1	
17	<b>WASHER, 8.4 FLAT ZINC</b>	F81054-1	2	
18	<b>BOLT, M8X20MM, HEX HEAD,GR 5.8 ZINC</b>	F81002-4	2	



7.4 Blade Height Scale (Optional)

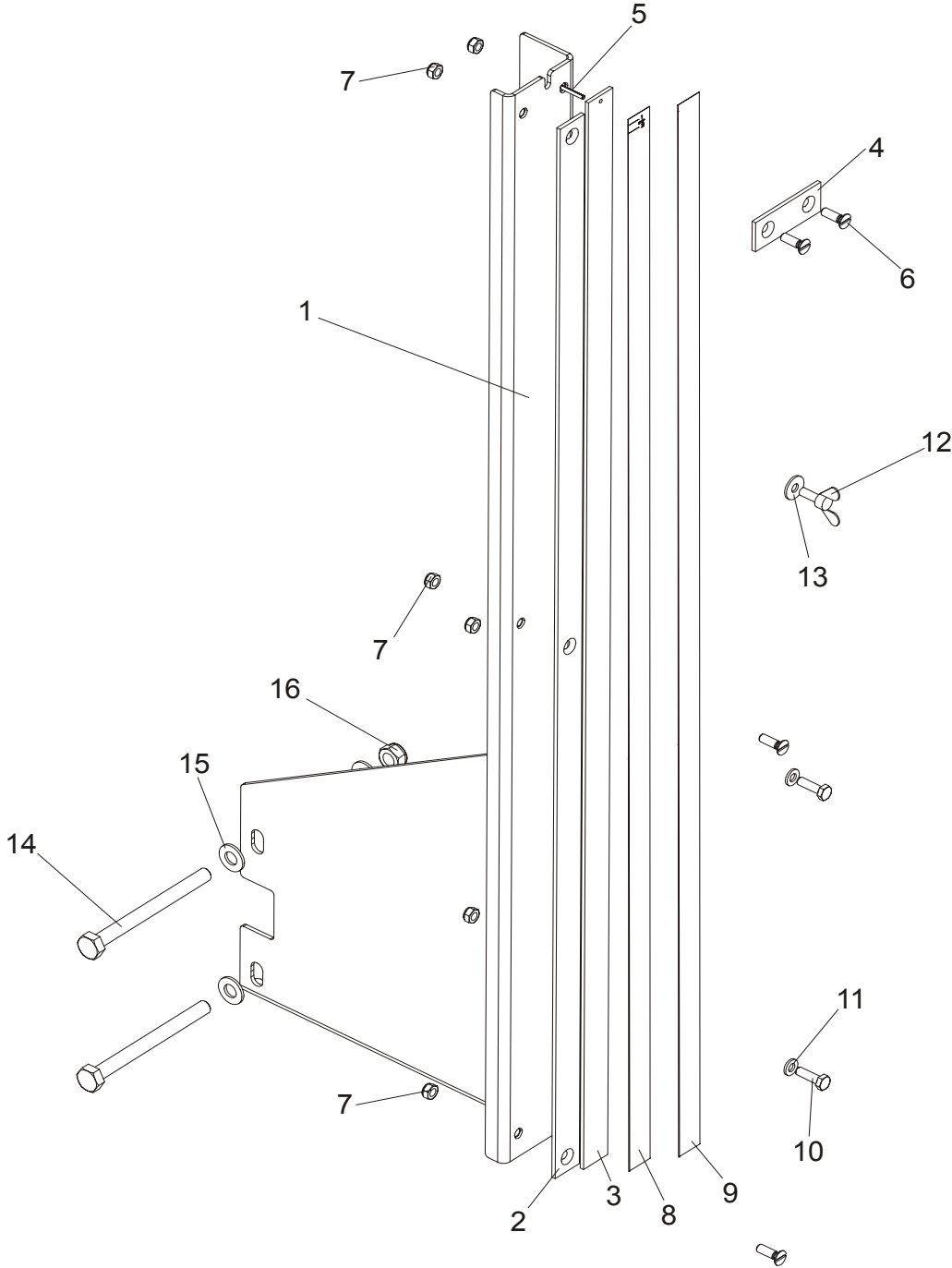

REF	DESCRIPTION (◆ Indicates Parts Available In Assemblies Only)	PART #	QTY.
	<b>BRACKET, BLADE HEIGHT SCALE COMPLETE</b>	<b>095964</b>	1
1	Bracket, Blade Height Scale Painted	095965-1	1
2	Plate, Decal Mount	092750	1
3	Plate, Inch Decal Mount	093133	1

## 7

**Up/Down System***Blade Height Scale (Optional)*

4	BAR, SCALE MOUNT	093134	1	
5	PIN, 3x20 ROLL ZINC	F81044-5	1	
6	screw, M6x20- 4.8-B slotted countersunk head zinc	F81001-31	3	
7	Nut, M6-8-B hex nylon zinc lock	F81031-2	6	
8	decal, LT20 0-80CM centimeter scale	091239	1	
9	Decal, 16-40CM Metric Decal, 45-63CM Metric	P12040-1 P12040-2	1	
10	<b>BOLT, M6X20-8.8 HEX HEAD FULL THREAD ZINC</b>	F81001-2	2	
11	<b>WASHER, 6.4 FLAT ZINC</b>	F81053-1	2	
12	<b>SCREW, M6X16 BN276 DIN 316 WING</b>	F81001-16	1	
13	<b>WASHER, 6.5 SPECIAL FLAT ZINC</b>	F81053-11	1	
14	<b>BOLT, M10X115-8.8 HEX HEAD ZINC</b>	F81003-19	2	
15	<b>WASHER, 10.5 FLAT ZINC</b>	F81055-1	4	
16	<b>NUT, M10-8-B HEX NYLON ZINC LOCK</b>	F81033-1	2	