

Wood-Mizer®

Replacement Parts Manual

LT15SC S4E15
LT15SC M4E15

rev. A2.05
rev. A2.05



Safety is our #1 concern! Read and understand all safety information and instructions before operating, setting up or maintaining this machine.

Form #797

Table of Contents

Section-Page

SECTION 1	GENERAL INFORMATION	1-1
1.1	How To Use the Parts List.....	1-1
1.2	Sample Assembly	1-1
SECTION 2	BED FRAME	2-1
2.1	Log Side Support Assembly	2-1
2.2	Bed Section Connecting Hardware	2-2
2.3	Stationary Leg Kit	2-4
2.4	Outrigger Leg Kit	2-5
2.5	Log Clamp Assembly	2-6
2.6	Auxiliary Bed Rail Assembly	2-7
2.7	Manual Toe Board (Optional)	2-8
2.8	Complete Winch	2-10
2.9	”M” Type Bed Frame Section (LT15 Sawmills Only).....	2-12
	2-12
2.10	”S” Type Bed Frame Section, LT15 1950	2-13
2.11	Mast Track Extension	2-14
2.12	Mast Track Extension Tube	2-15
2.13	Additional Bed Frame Sections with Outrigger Legs	2-16
2.14	Log Loading Ramp Assembly 097977	2-17
2.15	Loading Ramp Assembly 097483	2-18
2.16	Ramp Bracket 507518	2-19
SECTION 3	BLADE GUIDE ROLLERS & ARM	3-1
3.1	Blade Guide Assembly, Idle Side	3-1
3.2	Blade Guide Assembly, Drive Side.....	3-2
3.3	Blade Guide Roller Guard (LT15SC only)	3-3
3.4	Blade Guide Arm Assembly (094136)	3-4
SECTION 4	BLADE WHEELS & TENSIONER	4-1
4.1	Blade Wheel Assembly, Drive Side	4-1
4.2	Wide Blade Wheel Assembly, Drive Side, E15 Motor	4-2
4.3	Blade Wheel Assembly, Idle Side	4-3
4.4	Blade Tensioner Assembly	4-5
4.5	Motor Assembly	4-7
SECTION 5	SAW HEAD	5-1
5.1	Blade Housing Cover	5-1
5.2	Water Lube Assembly	5-3
5.3	Blade Lube System (not available in EC version).....	5-4
5.4	LT15AC Saw Head Decals	5-5
5.5	Control Box	5-7
5.6	Electrical Box	5-8
5.7	Mounting Brackets of the Electric Box (230V Version Only).....	5-9
5.8	Control Box - non-CE Version (Part No. 501280)	5-10
5.9	Control Box, LT15SC (Part No. 538731)	5-12

Table of Contents

Section-Page

SECTION 6	FEED SYSTEM	6-1
6.1	Feed Crank Assembly.....	6-1
6.2	Track Rail, Rollers & Travel Pins	6-3
6.3	Track Roller Cover Assembly	6-5
6.4	Feed Rope, Rope Guide System & Mount Brackets	6-6
6.5	Power Feed System - Optional	6-7
6.6	Power Cord Bracket (Part No. 097449)	6-9
SECTION 7	UP/DOWN SYSTEM	7-1
7.1	AC Up/Down Drive Assembly.....	7-2
7.2	Service Kit, LT15 Up/Down System.....	7-5
7.3	Slide Pads & Blade Height Scale Indicator.....	7-6
7.4	Blade Height Scale	7-8

SECTION 1 GENERAL INFORMATION

1.1 How To Use the Parts List

- Use the index above to locate the assembly that contains the part you need.
- Go to the appropriate section and locate the part in the illustration.
- Use the number pointing to the part to locate the correct part number and description in the table.
- Parts shown indented under another part are included with that part.
- Parts marked with a diamond (◆) are only available in the assembly listed above the part.

See the sample table below. Sample Part #A01111 includes part F02222-2 and subassembly A03333. Subassembly A03333 includes part S04444-4 and subassembly K05555. The diamond (◆) indicates that S04444-4 is not available except in subassembly A03333. Subassembly K05555 includes parts M06666 and F07777-77. The diamond (◆) indicates M06666 is not available except in subassembly K05555.

1.2 Sample Assembly				
REF.	DESCRIPTION (◆ Indicates Parts Available In Assemblies Only)	PART #	QTY	
	Sample Assembly, Complete (Includes All Indented Parts Below)	A01111	1	
1	Sample Part	F02222-22	1	
	Sample Subassembly (Includes All Indented Parts Below)	A03333	1	
2	Sample Part (◆ Indicates Part Is Only Available With A03333)	S04444-4	1	◆
	Sample Subassembly (Includes All Indented Parts Below)	K05555	1	
3	Sample Part (◆ Indicates Part Is Only Available With K05555)	M06666	2	◆
4	Sample Part	F07777-77	1	

To Order Parts:

- From Europe call our European Headquarters and Manufacturing Facility in Kolo, Poland at **+48-63-2626000**. From the continental U.S., call our toll-free Parts hotline at **1-800-525-8100**. Have your customer number, vehicle identification number, and part numbers ready when you call. From other international locations, contact the Wood-Mizer distributor in your area for parts.

Office Hours:

Country	Monday - Friday	Saturday	Sunday
Poland	7-15	Closed	Closed
US	8 a.m.- 5 p.m.	8 a.m.- 12 p.m.	Closed



CAUTION! It is strongly recommended that only original spare parts be used.

SECTION 2 BED FRAME

2.1 Log Side Support Assembly

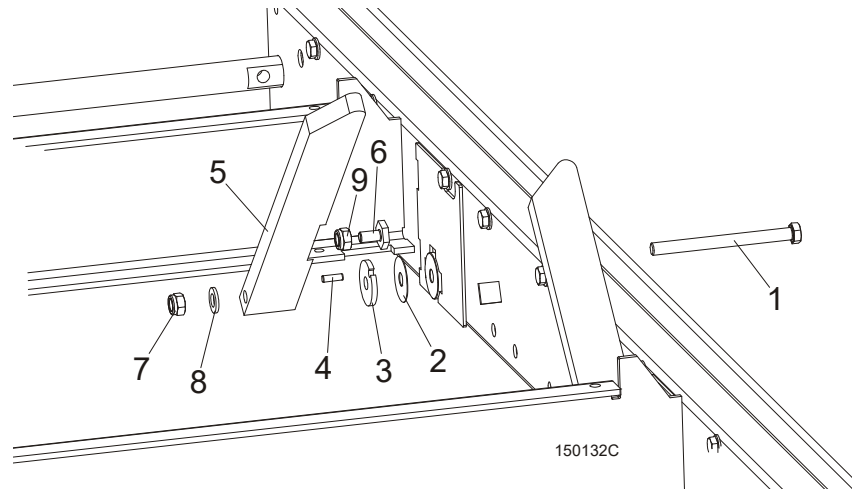

REF.	DESCRIPTION (◆ Indicates Parts Available In Assemblies Only)	PART #	QTY
1	BOLT, M12X140-8.8 HEX HEAD ZINC	F81004-35	1
2	WASHER, 33/64 X 1 3/4 X 1/32" NYLON	014972	1
3	WASHER, LT15 THICK SPACER	085981-1	1
	SUPPORT, LT15 LOG SIDE COMPLETE	085982-1	1
4	PIN, H 6n6x20 60HRC ROLL	100472	1
5	PLATE, LT15 LOG SIDE SUPPORT	085980	1
6	BOLT, M10x20 SPECIAL	100076-1	1
7	NUT, M12-8 HEX NYLON ZINC LOCK	F81034-2	1
8	WASHER, 13 FLAT ZINC	F81056-1	1
9	NUT, M10-8-B HEX ZINC	F81033-3	1

2.2 Bed Section Connecting Hardware

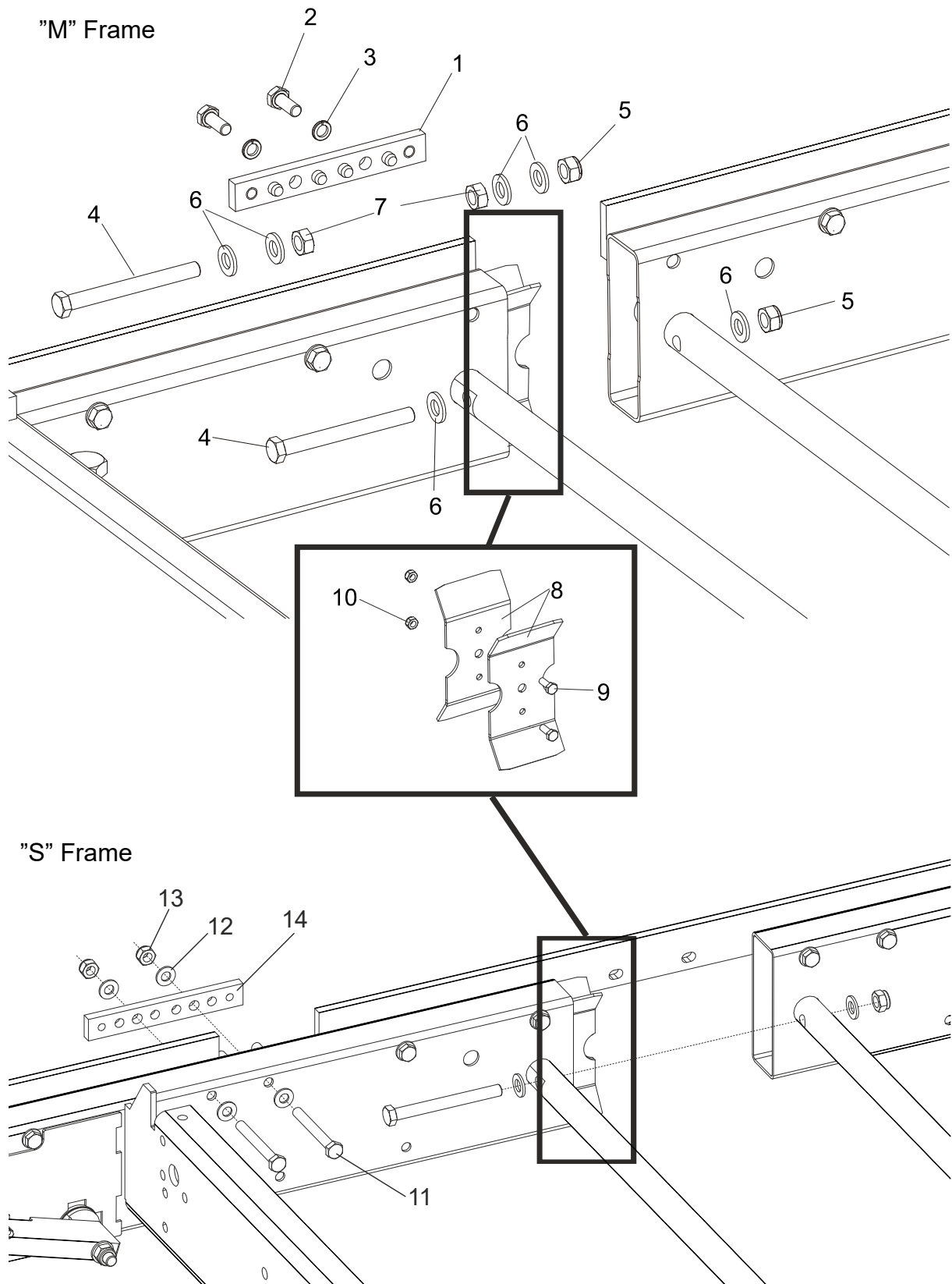

REF.	DESCRIPTION (◆ Indicates Parts Available In Assemblies Only)	PART #	QTY	
1	SPLICE, TRACK BAR PINNED ZINC-PLATED	086659-1	1	
2	BOLT, M10x25-8.8 HEX HEAD FULL THREAD ZINC	F81003-11	2	
3	WASHER, 10.2 SPLIT LOCK ZINC	F81055-2	2	
4	BOLT, M12x120 8.8 HEX HEAD ZINC	F81004-38	2	
5	NUT, M12-8 HEX NYLON ZINC LOCK	F81034-2	2	
6	WASHER, 13 FLAT ZINC	F81056-1	6	
7	NUT, M12-8-B HEX ZINC	F81034-1	2	
	CONNECTOR, LT15 BED FRAME SECTION	506288 ¹	2	
8	PLATE, BED SECTION CONNECTOR	506287-1	1	
9	BOLT, M6x16 8.8 HEX HEAD FULL THREAD ZINC	F81001-15	2	
10	NUT, M6-8-B HEX NYLON ZINC LOCK	F81031-2	2	
11	BOLT, M10X85-8.8 HEX HEAD ZINC	F81003-125	2	
12	WASHER, 10.5 FLAT ZINC	F81055-1	4	
13	NUT, M10-8-B HEX NYLON ZINC LOCK	F81033-1	2	
14	SPLICE, LT15 TRACK BAR PINNED	086660	1	

¹ 2 pieces for each bed section

2 BED FRAME

Stationary Leg Kit

2.3 Stationary Leg Kit

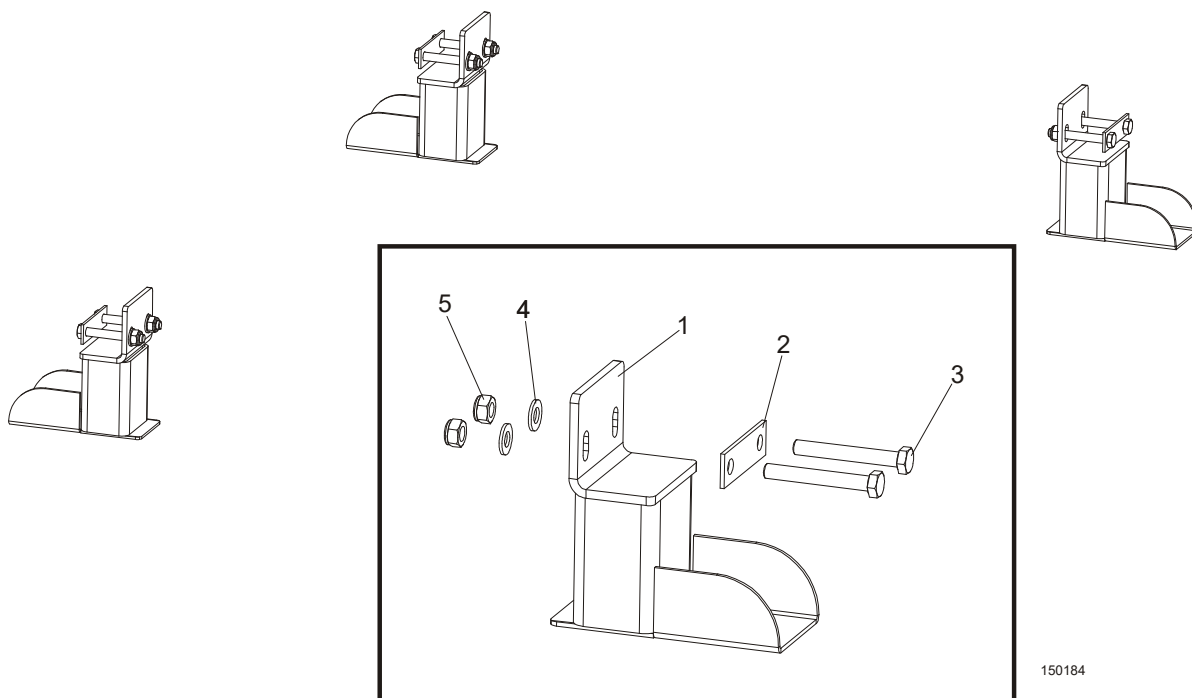

REF.	DESCRIPTION (◆ Indicates Parts Available In Assemblies Only)	PART #	QTY
	STATIONARY LEG KIT FOR 1950 MM BED SECTION	100069	1
1	Leg, LT15 Stationary Bed	100064-1	4
2	Washer, LT15 Bed Leg	085994-1	4
3	Bolt, M10x75-8.8 Hex Head Zinc	F81003-15	8
4	Washer, 10.5 Flat Zinc	F81055-1	8
5	Nut, M10-8-B Hex Nylon Zinc Lock	F81033-1	8
	STATIONARY LEG KIT FOR 2700 MM BED SECTION	100070	1
1	Leg, LT15 Stationary Bed	100064-1	6
2	Washer, LT15 Bed Leg	085994-1	6
3	Bolt, M10x75-8.8 Hex Head Zinc	F81003-15	12
4	Washer, 10.5 Flat Zinc	F81055-1	12
5	Nut, M10-8-B Hex Nylon Zinc Lock	F81033-1	12

2.4 Outrigger Leg Kit

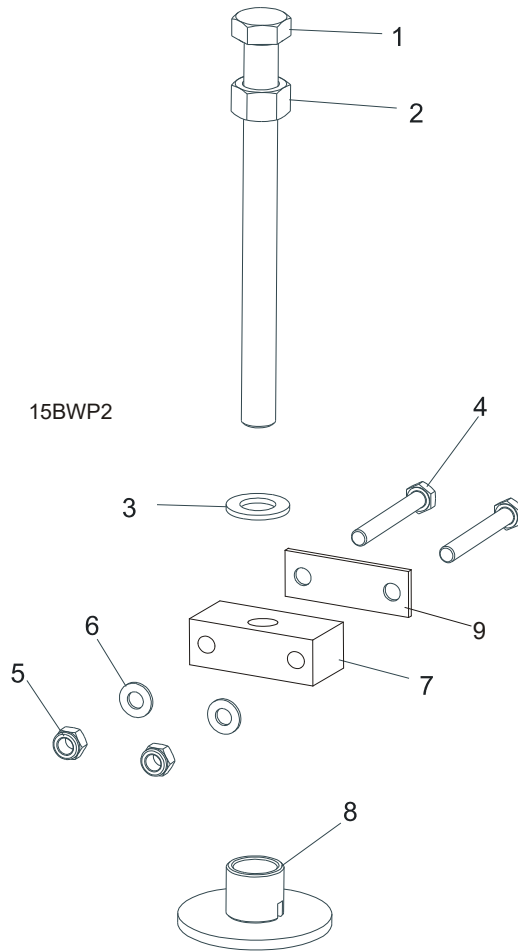

REF.	DESCRIPTION (◆ Indicates Parts Available In Assemblies Only)	PART #	QTY
	OUTRIGGER LEG KIT FOR 1950 MM BED SECTION (LT15S3)	095232 ¹	3
	OUTRIGGER LEG KIT FOR 2700 MM BED SECTION (LT15M2)	095234 ²	2
1	Bolt, M20x240-8.8 Hex Head Full Thread Zinc	F81007-1	1
2	Nut, M20-8 Hex Zinc	F81037-1	1
3	Washer, 21 Flat Zinc	F81059-2	1
4	Bolt, M10x120-8.8 Hex Head Zinc	F81003-58	2
5	Nut, M10-8-B Hex Nylon Zinc Lock	F81033-1	2
6	Washer, 10.5 Flat Zinc	F81055-1	2
7	Block, LT15 Leg Mount	095745-1	1
8	Plate Weldment, LT15 Leg Foot Zinc-Plated	087771-1	1
9	Washer, LT15 Bed	085994-1	1

¹ Four legs are mounted to each 1950-mm long bed section.

² Six legs are mounted to each 2700-mm long bed section.

2.5 Log Clamp Assembly

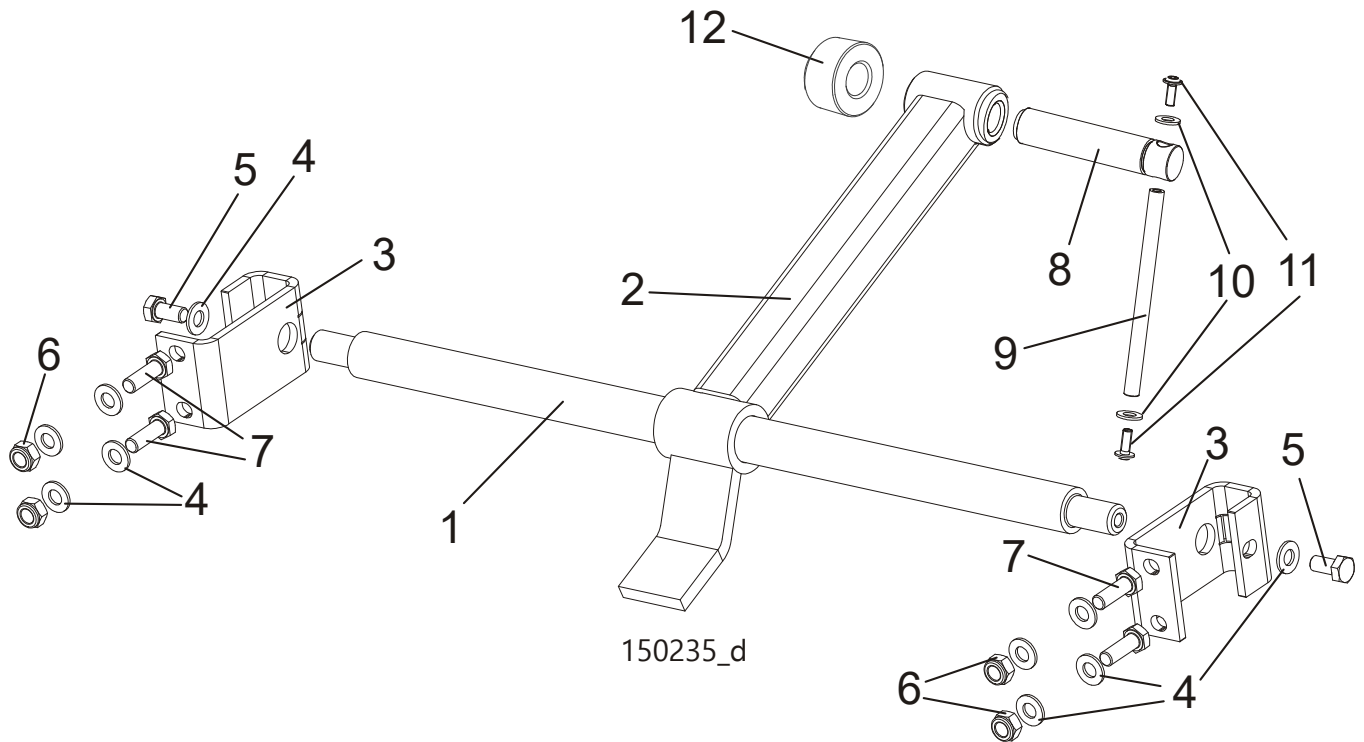

REF.	DESCRIPTION (◆ Indicates Parts Available In Assemblies Only)	PART #	QTY
	LOG CLAMP ASSEMBLY, LT15/15 COMPLETE	507565	2
1	ROD MAIN CLAMP	500343-1	1
2	ARM, CLAMP LX50 ZINC	530701-1	1
3	BRACKET, LOG CLAMP MOUNT ZINC	506535-1	2
4	WASHER, 10.5 FLAT ZINC	F81055-1	10
5	BOLT, M10x20-5.8 HEX HEAD FULL THREAD ZINC	F81003-1	2
6	NUT, M10-8-B NYLON HEX ZINC LOCK	F81033-1	4
7	BOLT, M10X30-5.8 HEX HEAD FULL THREAD	F81003-2	4
	CLAMP BOLT - COMPLETE	507563	1
8	CLAMP BOLT	507463	1
	ROD - COMPLETE	511924	1
9	ROD, ZINC-PLATED	511923-1	1
10	WASHER, 8.4 FLAT ZINC	F81054-1	2
11	BOLT, M6x16 BN 11252 "BOSSARD"	F81001-24	2
12	CAP, MOUNTING	T00414	1

2.6 Auxiliary Bed Rail Assembly

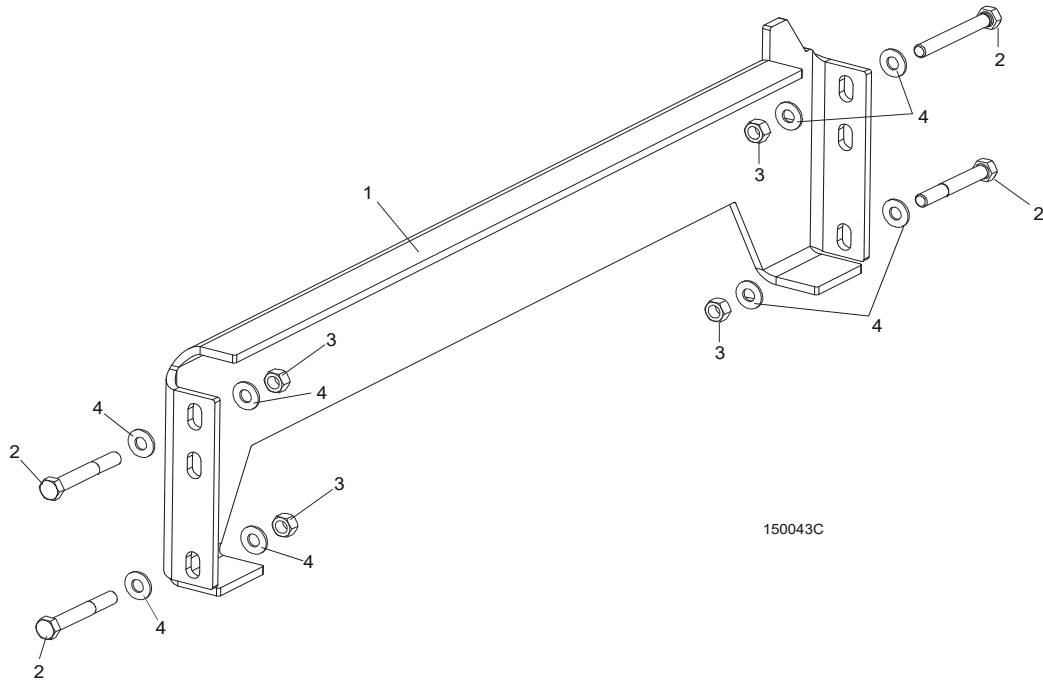

REF.	DESCRIPTION (◆ Indicates Parts Available In Assemblies Only)	PART #	QTY	
1	RAIL WELDMENT, LT15 AUXILIARY BED	095490-1	1	◆
2	BOLT M10X75-8.8 HEX HEAD ZINC	F81003-15	4	
3	NUT, M10-8-B HEX NYLON ZINC LOCK	F81033-1	4	
4	WASHER 10.5 ZINC FLAT	F81055-1	8	

2.7 Manual Toe Board (Optional)

534596_001_A
534596_MANUALS

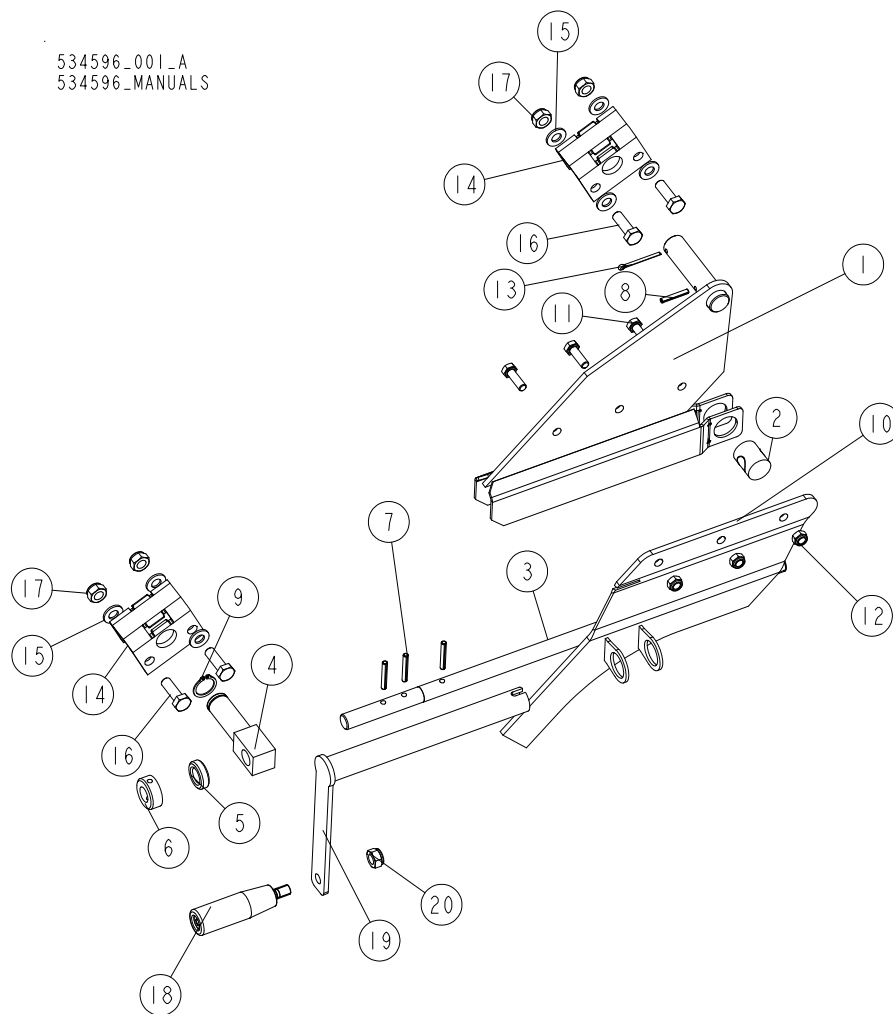

REF.	DESCRIPTION (* indicates parts available in assemblies only)	PART NO.	QTY
-	MANUAL TOE BOARD W/CRANK HANDLE (SINGLE)	534596	1
-	LT15 MANUAL TOE BOARD	534573	1
-	MANUAL TOE BOARD W/CRANK HANDLE (DOUBLE)	534596	1
-	LT15 MANUAL TOE BOARD	534573	2
-	HANDLE, TOE BOARD - COMPLETE	534595	1
1	PLATE WELDMENT, MANUAL TOE BOARD FRONT	094927-1	1
2	PIN, THREADED (MANUAL TOE BOARD)	090017	1
3	SHAFT, MANUAL TOE BOARD	580809-1	1
4	PIVOT, MANUAL TOE BOARD SHAFT ZINC-PLATED (1)	094931-1	1
5	BEARING, 5/8 THRUST	581701	1
6	RING, 16 ADJUSTING	F81039-30	1
7	PIN, 5X35-N-C PN-EN ISO 8752 ROLL	F81044-9	3
8	PIN, 4X30 ROLL ZINC	F81044-7	1
9	RING, Z 22 OUTSIDE RETAINING	F81090-24	1

REF.	DESCRIPTION (* indicates parts available in assemblies only)	PART NO.	QTY	
10	PLATE, MANUAL TOE BOARD COVER - COMPLETE	534593-1	1	
11	BOLT, M8X25-8.8-B HEX HEAD FULL THREAD ZINC	F81002-5	3	
12	NUT, M8-8-B HEX NYLON LOCK ZINC	F81032-2	3	
13	PIN, S-ZN, 4 X 25 COTTER	F81043-2	1	
14	PLATE	534574-1	2	
15	WASHER, 10.5 FLAT ZINC	F81055-1	7	
16	BOLT, DIN 933-M10X30 8.8-A2E	F81003-111	4	
17	NUT, M10-8-B NYLON HEX ZINC LOCK	F81033-1	4	
-	HANDLE, MANUAL TOE BOARD CRANK	500600	1	
18	KNOB, L=85 M10, RO11-M10 PLASTIC CRANK HANDLE	086338	1	
19	MANUAL TOE BOARD KNOB - WELDMENT	500599-1	1	
20	NUT, M10-8-B NYLON HEX ZINC LOCK	F81033-1	1	

2.8 Complete Winch

538991_001
538991_MANUAL

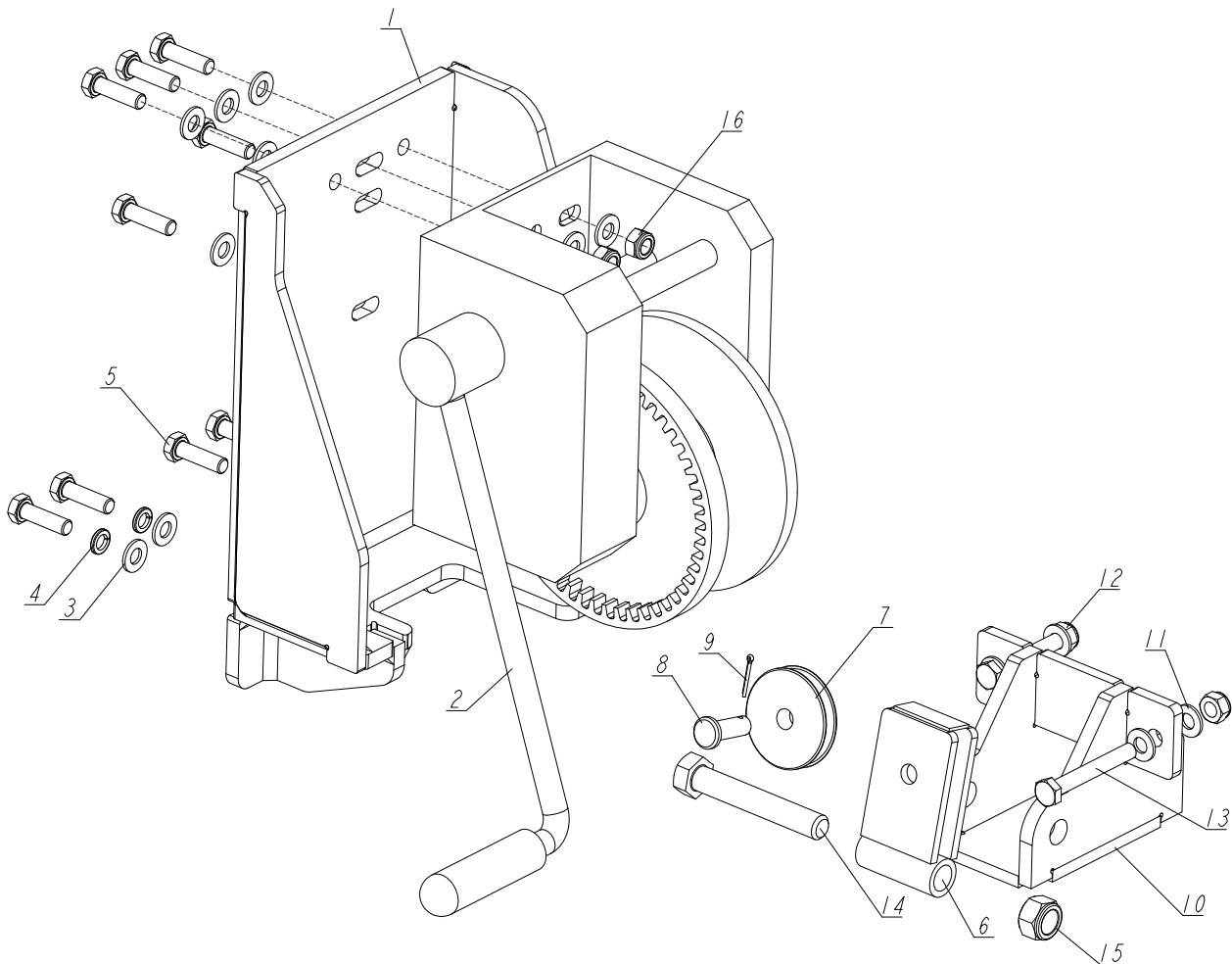

REF.	DESCRIPTION (* indicates parts available in assemblies only)	PART #	QTY
-	COMPLETE WINCH	538991	1
1	MOUNT WELDMENT, WINCH	538983-1	1
2	WINCH, AL-KO TYPE 901	096453	1
3	WASHER, 10.5 FLAT ZINC	F81055-1	12
4	WASHER, Z 10.2 SPLIT LOCK ZINC	F81055-2	4
5	BOLT, M10X35 8.8 HEX HEAD FULL THREAD ZINC	F81003-17	9
-	BRACKET, CABLE GUIDE PULLEY MOUNT - COMPLETE	538993	1
6	BRACKET, CABLE GUIDE PULLEY MOUNT	538990-1	1
7	PULLEY, CABLE GUIDE ZINC-PLATED	091273-1	1
8	PIN, B-12X35-FS/ZN5	F81049-1	1
9	PIN, S-ZN-2.5X20 COTTER	F81043-1	1
10	MOUNT WELDMENT, GUIDE PULLEY BRACKET	538994-1	1
11	WASHER, 10.5 FLAT ZINC	F81055-1	4
12	NUT, M10-8-B HEX NYLON ZINC LOCK	F81033-1	2

REF.	DESCRIPTION (* indicates parts available in assemblies only)	PART #	QTY	
13	BOLT, M10X75-8.8 HEX HEAD ZINC	F81003-15	2	
14	BOLT, M16X100-8.8 HEX HEAD FULL THREAD ZINC	F81006-2	1	
15	NUT, M16-8 HEX NYLON ZINC LOCK	F81036-2	1	
16	NUT, M10-8-B HEX NYLON ZINC LOCK	F81033-1	5	

2

BED FRAME

"M" Type Bed Frame Section (LT15 Sawmills Only)

2.9 "M" Type Bed Frame Section (LT15 Sawmills Only)

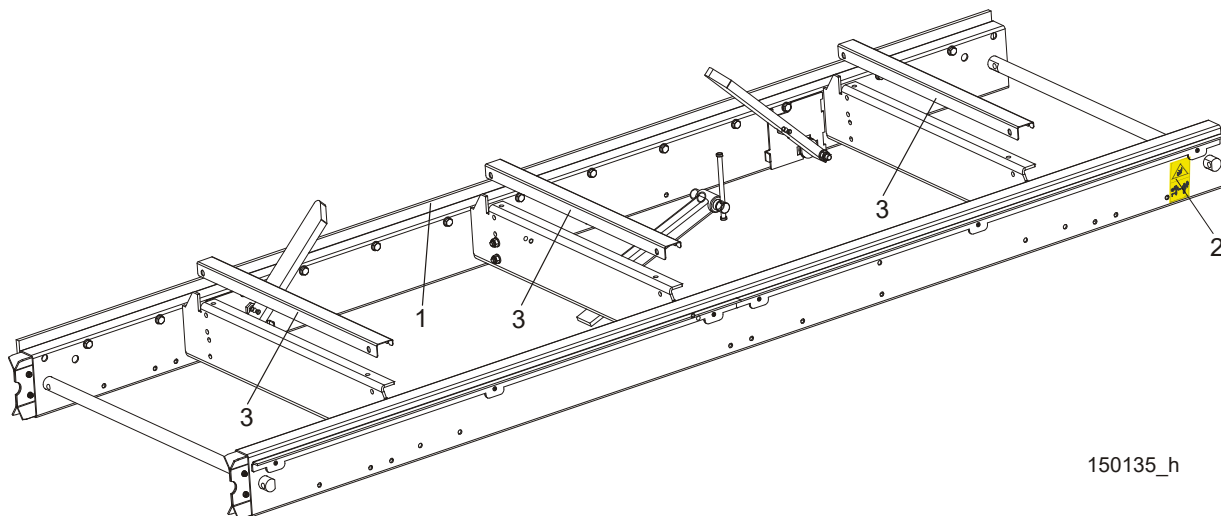

150135_h

REF.	DESCRIPTION (◆ Indicates Parts Available In Assemblies Only)	PART #	QTY
	LT15 BED SECTION ASSEMBLY - LONG	094697	
1	Bar, LT15 2700 Track Zinc-Plated	538935-1	1
2	DECAL, KEEP AWAY DANGER, PICTOGRAM	099221	1
3	COVER, BED RAIL LT15/15	509300 ¹	3

¹ Option

2.10 "S" Type Bed Frame Section, LT15 1950

538800_001
538800_MANUALS

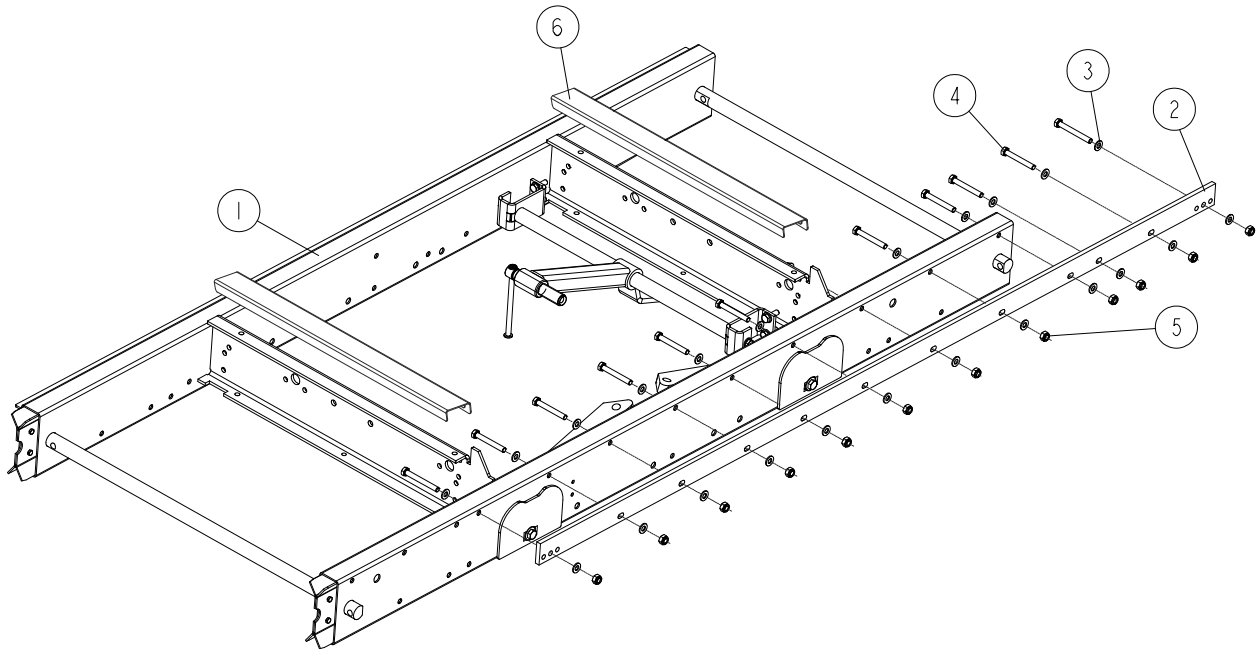

REF.	DESCRIPTION (◆ Indicates Parts Available In Assemblies Only)	PART #	QTY
-	SECTION, LT 15 1950 BED FRAME - COMPLETE	538800	1
1	FRAME WELDMENT, LT15 1950 BED	538801-1	1
2	RAIL, LT15 1950 TRACK	538799-1	1
3	WASHER, 10.5 FLAT ZINC	F81055-1	24
4	BOLT, M10X75-8.8 HEX HEAD ZINC	F81003-15	10
5	NUT, M10-8-B HEX NYLON ZINC LOCK	F81033-1	12
6	COVER, LT15 BED RAIL	509300 ¹	2

¹ Option

2.11 Mast Track Extension

538808_001_A
538808_MANUAL

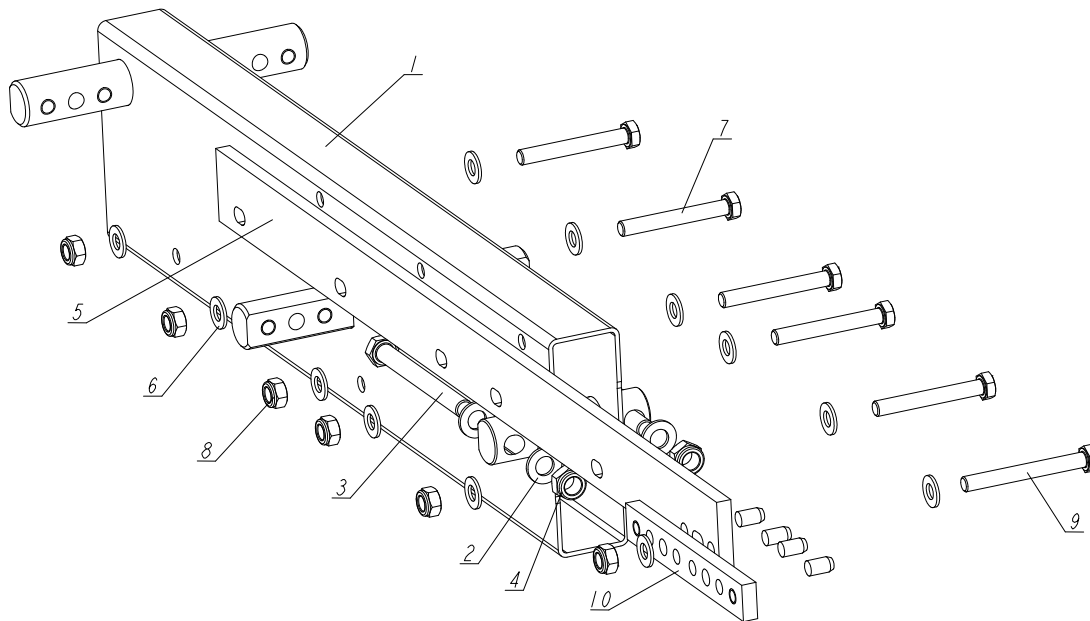

REF	DESCRIPTION (◆ indicates parts available in assemblies only)	PART #	QTY
-	EXTENSION, MAST TRACK REAR - COMPLETE	538808	1
1	TUBE, MAST TRACK EXTENSION	538809-1	1
2	WASHER, 13 FLAT ZINC	F81056-1	4
3	BOLT M12X120 8.8 FE/ZN5	F81004-38	2
4	NUT, M12 8 HEX NYLON ZINC LOCK	F81034-2	2
5	BAR, EXTENSION TRACK ZINC-PLATED	538811-1	1
6	WASHER, 10.5 FLAT ZINC	F81055-1	12
7	BOLT, M10X75-8.8 HEX HEAD ZINC	F81003-15	5
8	NUT, M10-8-B HEX NYLON ZINC LOCK	F81033-1	6
9	BOLT, M10X85-8.8 HEX HEAD ZINC	F81003-125	1
10	BED SECTION CONNECTOR, LT15	086659-1	1

2.12 Mast Track Extension Tube

538807_001_A
 538807_MANUALS

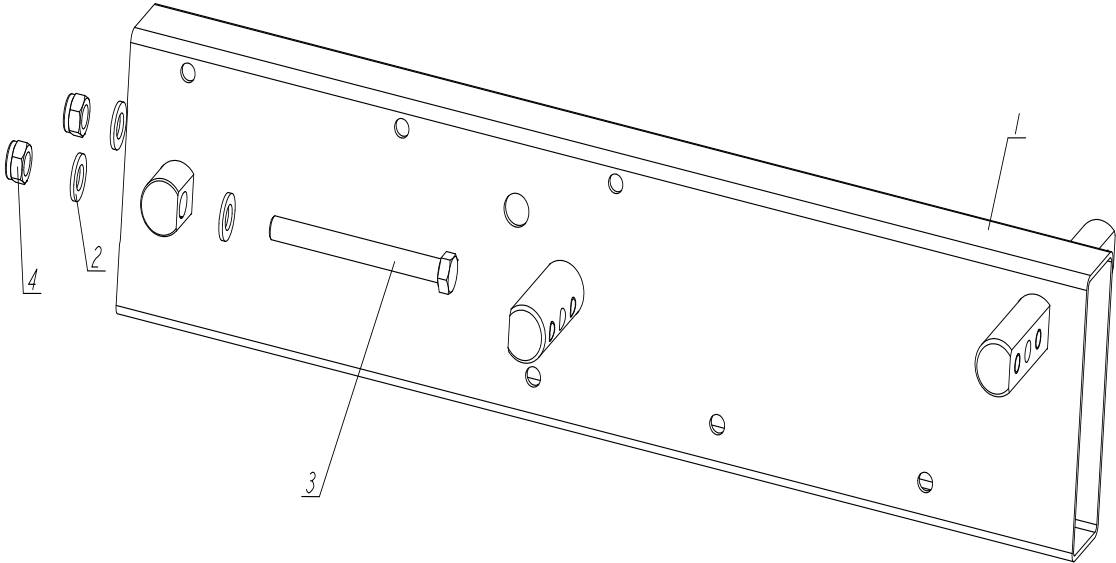

REF	DESCRIPTION (◆ indicates parts available in assemblies only)	PART #	QTY	
-	EXTENSION, MAST TRACK FRONT - COMPLETE	538807	1	
1	TUBE, MAST TRACK EXTENSION	538809-1	1	
2	WASHER, 13 FLAT ZINC	F81056-1	4	
3	BOLT M12X120 8.8 FE/ZN5	F81004-38	2	
4	NUT, M12 8 HEX NYLON ZINC LOCK	F81034-2	2	

2.13 Additional Bed Frame Sections with Outrigger Legs

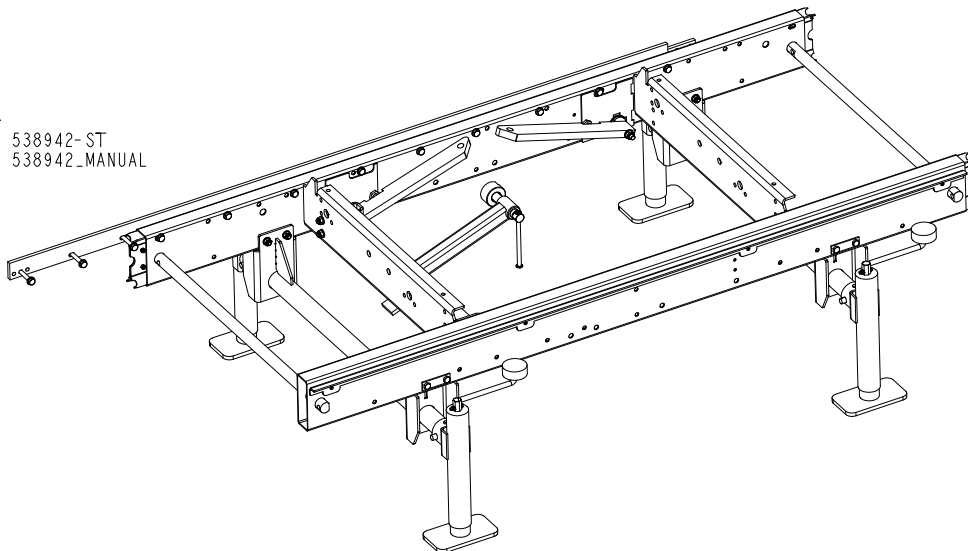
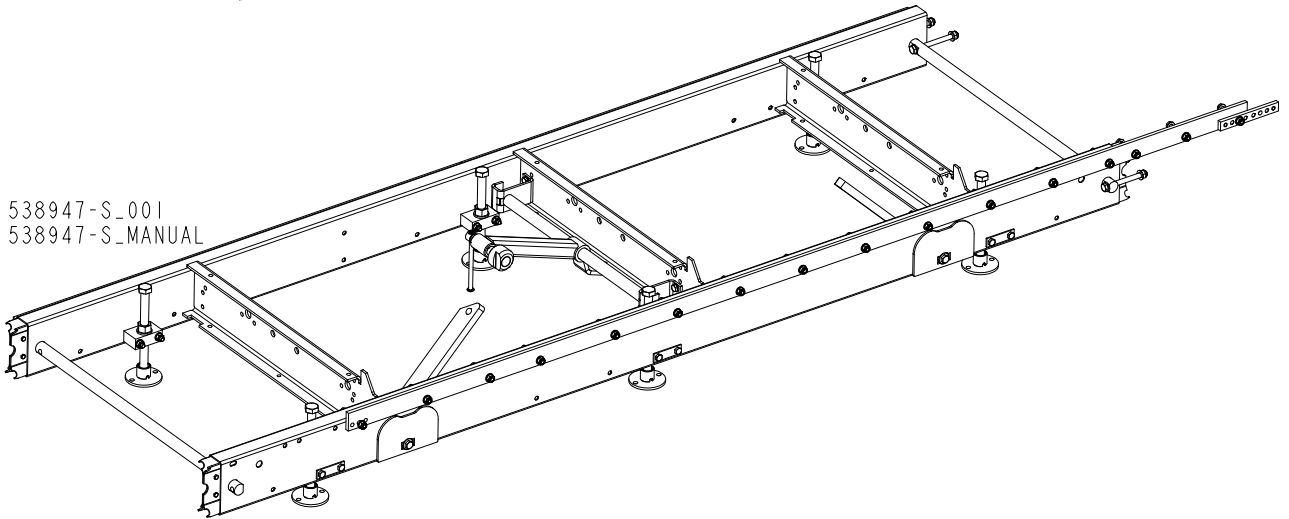
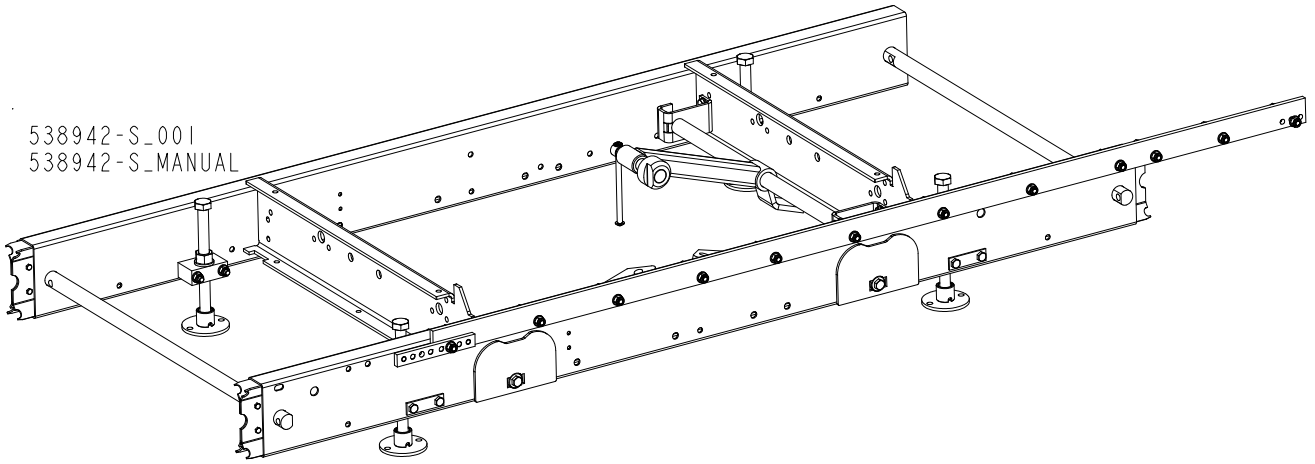

REF.	DESCRIPTION (◆ Indicates Parts Available In Assemblies Only)	PART #	QTY
	BED SECTION, UNIVERSAL S-TYPE, 1950MM SERVICE	538942-S	1
	BED SECTION, UNIVERSAL M-TYPE, 2700MM SERVICE	538947-S	1
	BED SECTION, UNIVERSAL S-TYPE, 1950MM SERVICE	538942-ST	1

2.14 Log Loading Ramp Assembly 097977

097977_001
097977

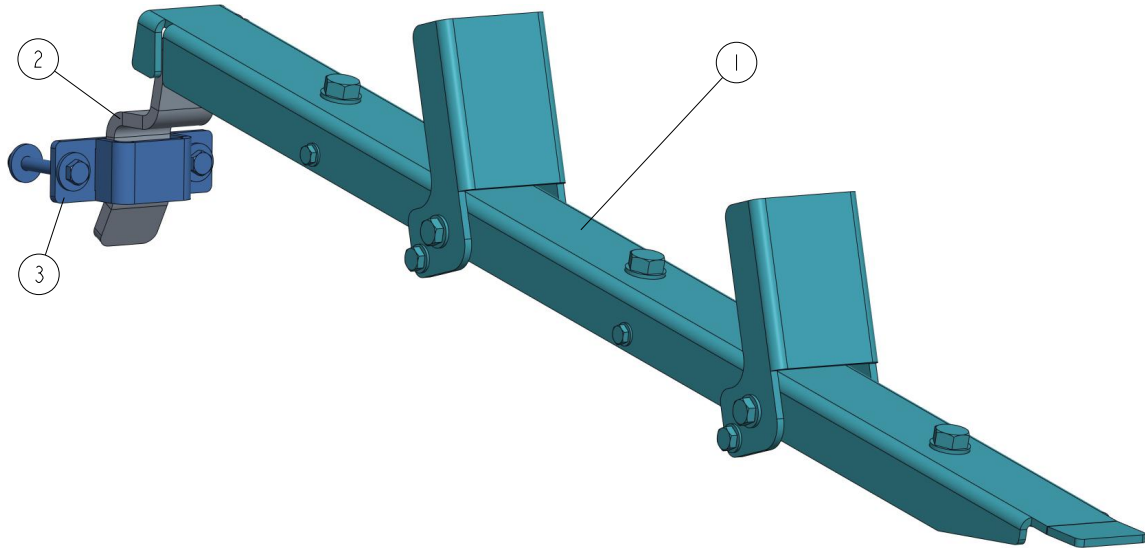

REF	DESCRIPTION (◆ indicates parts available in assemblies only)	PART #	QTY
-	RAMP ASSEMBLY, LOG LOADING, LT15 COMPL.	097977	1
1	RAMP ASSEMBLY, LOADING See Section 2.15	097483	1
2	BRACKET, LT15 RAMP ZINC-PLATED	097976-1	1
3	BRACKET, LT15 RAMP - COMPLETE See Section 2.16	507518	1

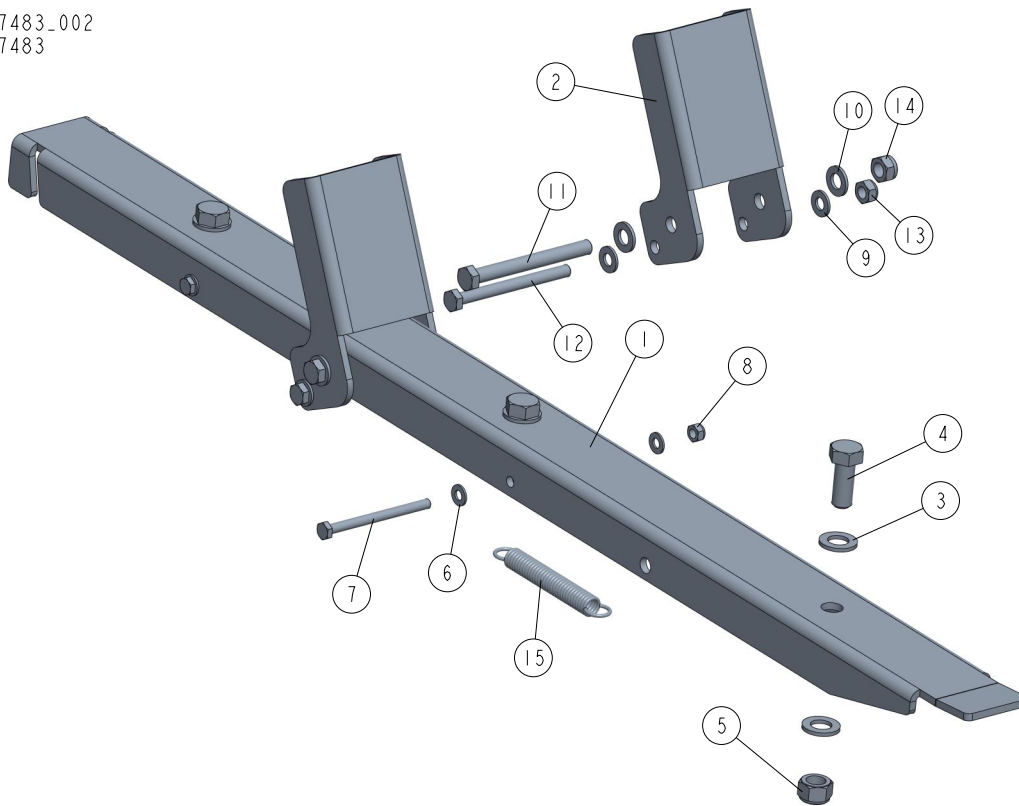
2.15 Loading Ramp Assembly 097483¹097483_002
097483

REF	DESCRIPTION (◆ indicates parts available in assemblies only)	PART #	QTY
-	RAMP ASSEMBLY, LOADING	097483	1
1	PLATE, LT10 LOADING RAMP - MAIN	097481-1	1
2	BRACKET, LOG LOADING STOP	097482-1	2
3	WASHER, 17 SPLIT LOCK ZINC	F81058-1	6
4	BOLT, M16X40-8.8 HEX HEAD FULL THREAD ZI	F81006-13	3
5	NUT, M16-8 HEX NYLON ZINC LOCK	F81036-2	3
6	WASHER, 8,4-FLAT ZINC	F81054-1	4
7	BOLT, M8X100-8.8 HEX HEAD ZINC	F81002-23	2
8	NUT, M8-8-B HEX NYLON ZINC LOCK	F81032-2	2
9	WASHER, 10.5 FLAT ZINC	F81055-1	4
10	WASHER, 13 FLAT ZINC	F81056-1	4
11	BOLT, M12X115-8.8-B HEX HEAD ZINC	F81004-33	2
12	BOLT, M10X110-8.8 HEX HEAD ZINC	F81003-43	2
13	NUT M10 ZC 8 NYLOCK DIN 982 ISO 7040	F81033-1	2
14	NUT, M12-8 HEX NYLON ZINC LOCK	F81034-2	2
15	SPRING, N1.9XN14.2X104	091865	2

1.(2x097483) included in assembly 586967

2.16 Ramp Bracket 507518

507518_001
507518

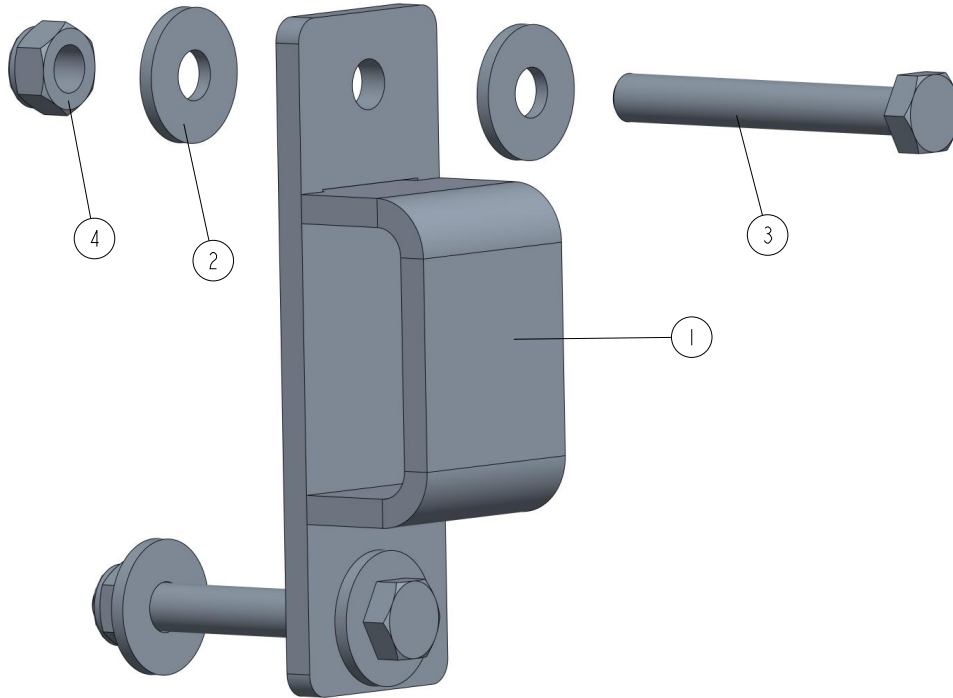

REF	DESCRIPTION (◆ indicates parts available in assemblies only)	PART #	QTY	
-	BRACKET, LT15 RAMP - COMPLETE	507518	1	
1	BRACKET WELDMENT, LT15 RAMP	507517-1	1	
2	WASHER 10,5 ZC FENDER DIN 9021 ISO 7093	F81055-6	4	
3	BOLT, M10X75-8.8-FE/ZN5 PN-M/82101	F81003-15	2	
4	NUT M10 ZC 8 NYLOCK DIN 982 ISO 7040	F81033-1	2	

3 BLADE GUIDE ROLLERS & ARM

Blade Guide Assembly, Idle Side

SECTION 3 BLADE GUIDE ROLLERS & ARM

3.1 Blade Guide Assembly, Idle Side

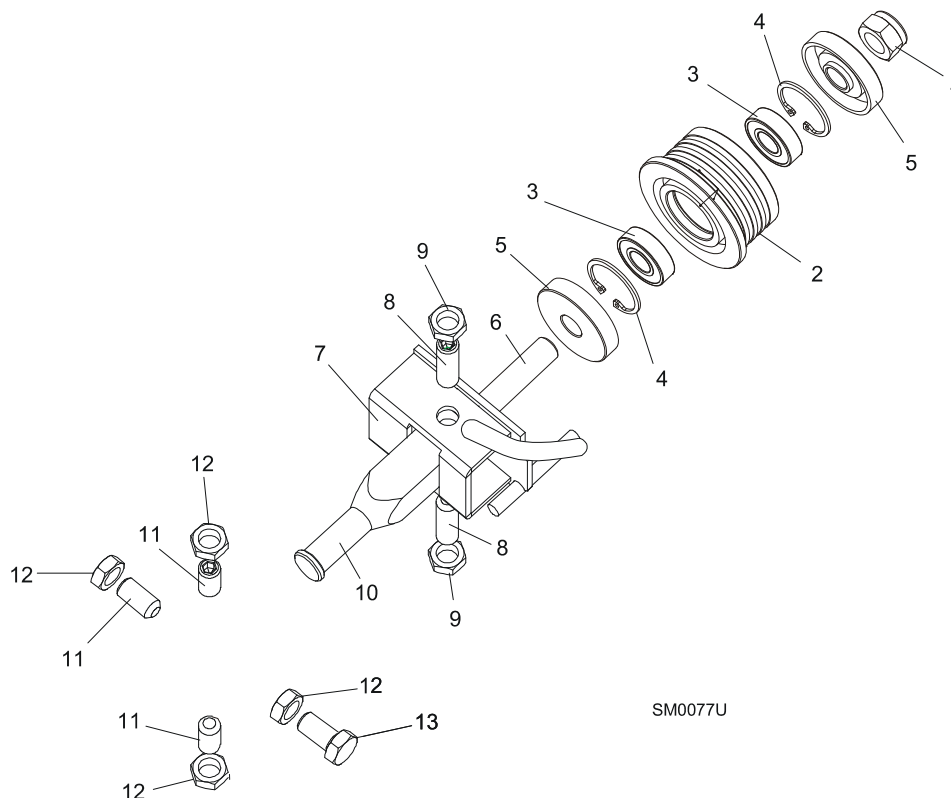

REF.	DESCRIPTION (◆ Indicates Parts Available In Assemblies Only)	PART #	QTY	
	BLADE GUIDE ASSEMBLY, IDLE SIDE	094683	1	
	Roller, Blade Guide Complete Standard	087887	1	
1	Nut, M12-8 Hex Nylon Zinc Lock	F81034-2	1	
2	Roller, Blade Guide Narrow	087889	1	◆
3	Bearing, 6001 2RSR FAG	087893	2	
4	Ring, W28 Inside Retaining	F81090-9	1	
5	Washer, Zinc-plated Spacer	087891-1	2	
6	Shaft, Blade Guide Roller Zinc-plated	087763-1	1	
7	Bracket Weldment, Idle Side Blade Guide Painted	094681-1	1	
8	Screw, M10x1x40 DIN 913 A2-70 Set Stainless Steel	F81015-2	2	
9	Nut, M10x1-04-ST-A2 ISO 8675 Thin	F81033-10	2	
10	Shaft, Zinc-plated Blade Guide Mount	503588-1	1	
11	SCREW, M10X1X25 DIN 913 SET STAINLESS STEEL	F81015-4	4	
12	NUT, M10x1-04-ST-A2 ISO 8675 THIN	F81033-10	4	

3.2 Blade Guide Assembly, Drive Side

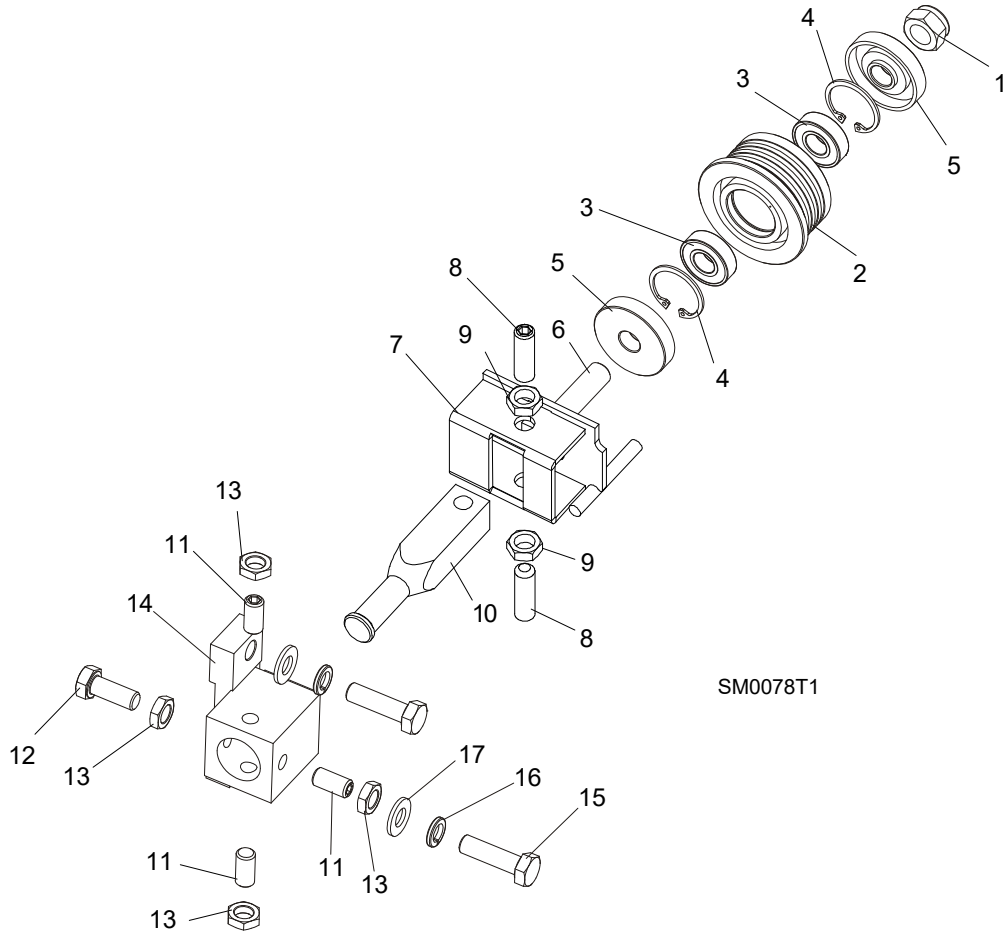

REF.	DESCRIPTION (◆ Indicates Parts Available In Assemblies Only)	PART #	QTY
	BLADE GUIDE ASSEMBLY, DRIVE SIDE	094682	1
	Roller, Blade Guide Complete Standard	087887	1
1	Nut, M12-8 Hex Nylon Zinc Lock	F81034-2	1
2	Roller, Blade Guide Narrow	087889	1
3	Bearing, 6001 2RSR FAG	087893	2
4	Ring, W28 Inside Retaining	F81090-9	1
5	Washer, Zinc-plated Spacer	087891-1	2
6	Shaft, Blade Guide Roller Zinc-plated	087763-1	1
7	Bracket Weldment, Blade Guide Painted	094679-1	1
	Screw Kit, Blade Guide Adjustment w/Nuts (for two blade guide assemblies)	K09942	1
8	Screw, M10x1x40 DIN 913 A2-70 Set Stainless Steel	F81015-2	2
9	Nut, M10x1-04-ST-A2 ISO 8675 Thin	F81033-10	2
10	Shaft, Zinc-plated Blade Guide Mount	503588-1	1
11	SCREW, M10X1X25 DIN 913 SET STAINLESS STEEL	F81015-4	3
12	BOLT, M10X1X25 DIN 933 STAINLESS STEEL	F81003-28	1
13	NUT, M10x1-04-ST-A2 ISO 8675 THIN	F81033-10	4
14	TUBE, BLADE GUIDE MOUNT	087744	1
15	BOLT, M10X35-8.8 HEX HEAD FULL THREAD ZINC	F81003-17	2
16	WASHER, 10.2 SPLIT LOCK ZINC	F81055-2	2
17	WASHER, 10.5 FLAT ZINC	F81055-1	2

3 BLADE GUIDE ROLLERS & ARM

Blade Guide Roller Guard (LT15SC only)

3.3 Blade Guide Roller Guard (LT15SC only)

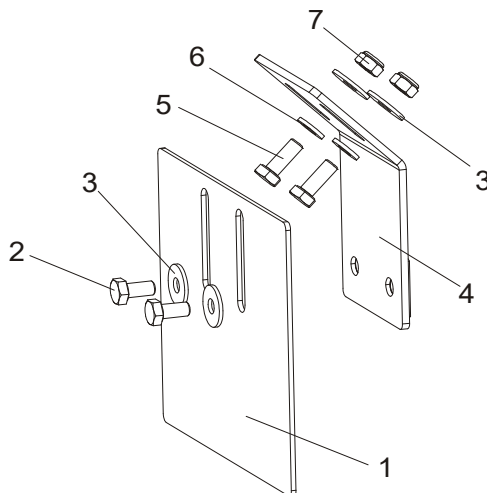

REF.	DESCRIPTION (◆ Indicates Parts Available In Assemblies Only)	PART #	QTY
1	GUARD, BLADE GUIDE ROLLER PAINTED	092379-1	1
2	BOLT, M6X12-8.8 HEX HEAD FULL THREAD ZINC	F81001-7	2
3	WASHER, 6.5 SPECIAL FLAT ZINC	F81053-11	4
4	BRACKET, ROLLER GUARD MOUNT PAINTED	092378-1	1
5	BOLT, M6X16 8.8 HEX HEAD FULL THREAD ZINC	F81001-15	2
6	WASHER, 6.4 FLAT ZINC	F81053-1	2
7	NUT, M6-8-B HEX NYLON ZINC LOCK	F81031-2	2

3.4 Blade Guide Arm Assembly (094136)

094136_001_A
094136_MANUAL

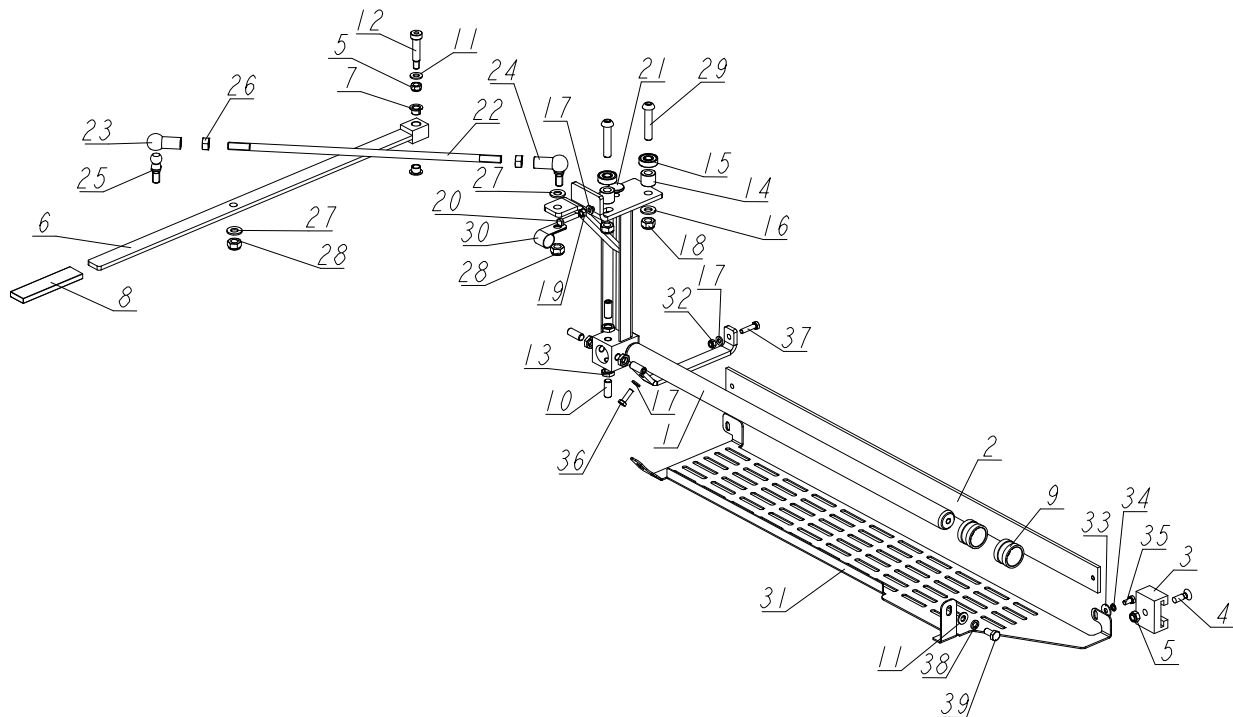

REF.	DESCRIPTION (* indicates parts available in assemblies only)	PART #	QTY
-	BLADE GUIDE ARM W/LEVER - COMPLETE	094136	1
1	ARM WELDMENT, BLADE GUIDE	094138-1	1
2	BAR, BLADE GUARD	088306	1
3	BRACKET, BLADE GUIDE ARM GUIDE	088305	1
4	SCREW, M8X25-5.8 CROSS RECESSED COUNTERS	F81002-51	1
5	NUT, M8-8-B HEX NYLON ZINC LOCK	F81032-2	2
-	LEVER ASSEMBLY, BLADE GUIDE ARM ADJUSTME	531630	1
6	LEVER, BLADE GUIDE ARM ADJUSTMENT	531628-1	1
7	BEARING, TUF1 10.090 (CX)	099074	2
8	CAP, RRWA 91626 HANDLE END	086875	1
9	BUSHING, BLADE GUIDE	086684	2
10	SCREW, M10X1X25 DIN 913 STAINLESS STEEL	F81015-4	4
11	WASHER, 8.4 FLAT ZINC	F81054-1	2
12	BOLT, 10/M8X35 12.9 ISO7379 SHOULDER	F81003-63	1
13	NUT, M10X1-04-ST-A2 ISO 8675 THIN	F81033-10	4
14	BUSHING, 11/20-17 ZINC-PLATED	094255-1	2
15	BEARING, 6000.2RSR	087471	2
16	WASHER, 10.5 FLAT ZINC	F81055-1	2
17	WASHER, 6.4 FLAT ZINC	F81053-1	5
18	NUT, M10-8-B HEX NYLON ZINC LOCK	F81033-1	2
19	NUT, M6 8 HEX ZINC	F81031-1	1
20	BOLT, M6X30-8.8 HEX HEAD FULL THREAD ZIN	F81001-8	1
21	BUSHING, BLADE GUIDE ARM	095936	1
-	STUD BOLT ASSEMBLY, ARM LEVER CONNECTION	094204	1

REF.	DESCRIPTION (* indicates parts available in assemblies only)	PART #	QTY	
22	BOLT, ZINC-PLATED STUD	094203-1	1	
23	SEAT, BALL	093824	1	
24	SEAT, BALL	093824-1	1	
25	STUD, 16/SW-13 DIN71803-C BN486 BALL	093823	2	
26	NUT, M10-8-B-HEX ZINC	F81033-3	2	
27	WASHER, 10.5 FLAT ZINC	F81055-1	2	
28	NUT, M10-8-B HEX NYLON ZINC LOCK	F81033-1	2	
29	BOLT, M10X50-8.8 HEX HEAD FULL THREAD ZI	F81003-131	2	
30	CLAMP, 5/8 EMT COATED	010748	1	
31	GUARD, BOTTOM	525592-1	1	
32	NUT, M6-8-B HEX NYLON ZINC LOCK	F81031-2	2	
33	WASHER, 6.5 SPECIAL FLAT ZINC	F81053-11	1	
34	WASHER, Z 6.1 SPLIT LOCK	F81053-3	1	
35	BOLT, M6X12-8.8 HEX HEAD FULL THREAD ZIN	F81001-7	1	
36	BOLT, M6X20 8.8 HEX HEAD FULL THREAD ZIN	F81001-2	1	
37	BOLT, M6X25-5.8 HEX HEAD FULL THREAD ZIN	F81001-3	1	
38	WASHER 8,2 SPLIT LOCK ZINC	F81054-4	1	
39	BOLT, M8X16 -8.8-B HEX HEAD FULL THREAD	F81002-20	1	

SECTION 4 BLADE WHEELS & TENSIONER

4.1 Blade Wheel Assembly, Drive Side

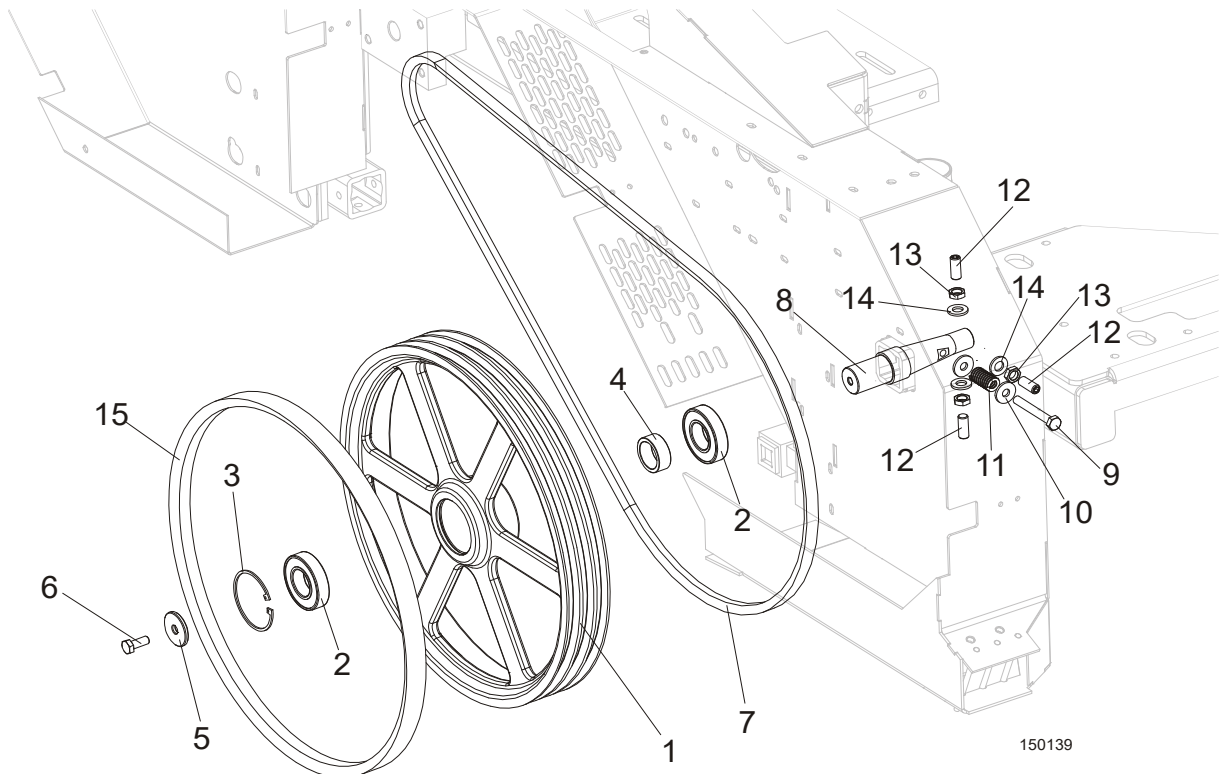

REF.	DESCRIPTION (◆ Indicates Parts Available In Assemblies Only)	PART #	QTY	
	BLADE WHEEL ASSEMBLY, LT15 DRIVE SIDE	093849	1	
1	WHEEL, LT15 DRIVE SIDE BLADE	014727 ¹	1	
2	BEARING, 6207-2RS 35X72X17 FAG	014811 ²	2	
3	RING, 72MM N5002-281 RETAINING	F04254-30	1	
4	BUSHING, LT15 BEARING SPACER	093851	1	
5	WASHER, LT15 DRIVE SIDE BLADE WHEEL	086286	1	
6	BOLT, M10X25-8.8 HEX HEAD FULL THREAD ZINC	F81003-11	1	
7	V-BELT, BX81, LT15	014819	1 ³	
8	SHAFT, LT15 DRIVE SIDE BLADE WHEEL	093850	1	
9	BOLT, M10X75-8.8 HEX HEAD ZINC	F81003-15	1	
10	WASHER, 10.5 SPECIAL FLAT ZINC	F81055-6	2	
11	SPRING, 19X38 COMPRESSION	034430	1	
12	SCREW, M12X1,25X30 DIN913 SET STAINLESS STEEL	F81016-1	3	
13	NUT, M12X1.25 DIN439 THIN STAINLESS STEEL	F81034-9	3	
14	WASHER, 13 FLAT ZINC	F81056-1	3	
15	V-BELT, B57	P04185-2	1	

¹ LT15 for Russian market is equipped with drive wheel No. 090646-1

² LT15 for Russian market is equipped with one bearing 014811 and one 092005 (wide)

³ LT15 for Russian market is equipped with two belts.

4

Blade Wheels & Tensioner

Wide Blade Wheel Assembly, Drive Side, E15 Motor

4.2 Wide Blade Wheel Assembly, Drive Side, E15 Motor

LT15SCS3EH15EP-E_001_C
 LT15SCS3EH15EP-E_MANUAL

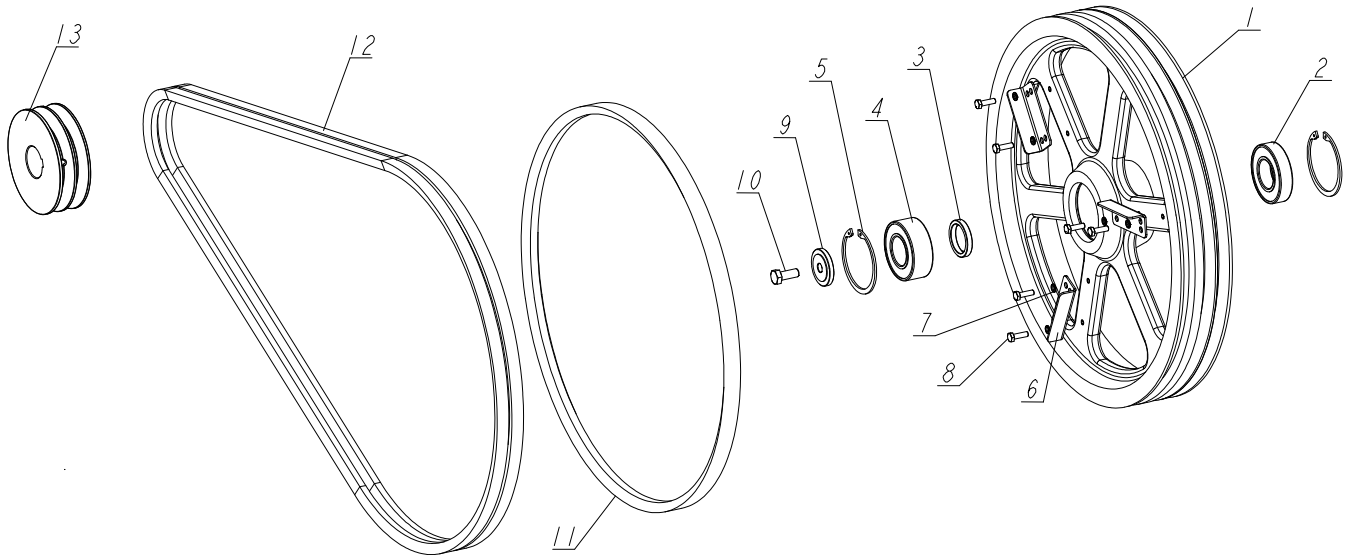

REF.	DESCRIPTION (◆ Indicates Parts Available In Assemblies Only)	PART #	QTY
-	BLADE WHEEL, DRIVE SIDE - COMPLETE	550620	1
1	WHEEL, LT20 DRIVE SIDE	090646-1	1
2	BEARING, 6207 -2RS1 SKF	014811	1
3	BUSHING, SPACER	096778	1
4	BEARING, 3207B.2RSR.TVH "FAG"	092005	1
5	RING, W72 INSIDE RETAINING	F81090-4	2
6	WING	097808-1	3
7	WASHER, Z 6.1 SPLIT LOCK ZINC	F81053-3	6
8	BOLT, M6X20 8.8 HEX HEAD FULL THREAD ZINC	F81001-2	6
9	WASHER, CLAMPING	092006	1
10	BOLT, M10X25 8.8 HEX HEAD FULL THREAD ZINC	F81003-11	1
11	BELT, B-57	P04185-2	1
12	V-BELT, 2BX81	014819-2	1
13	PULLEY, E15 MOTOR 2-GROOVE	091560	1

4.3 Blade Wheel Assembly, Idle Side

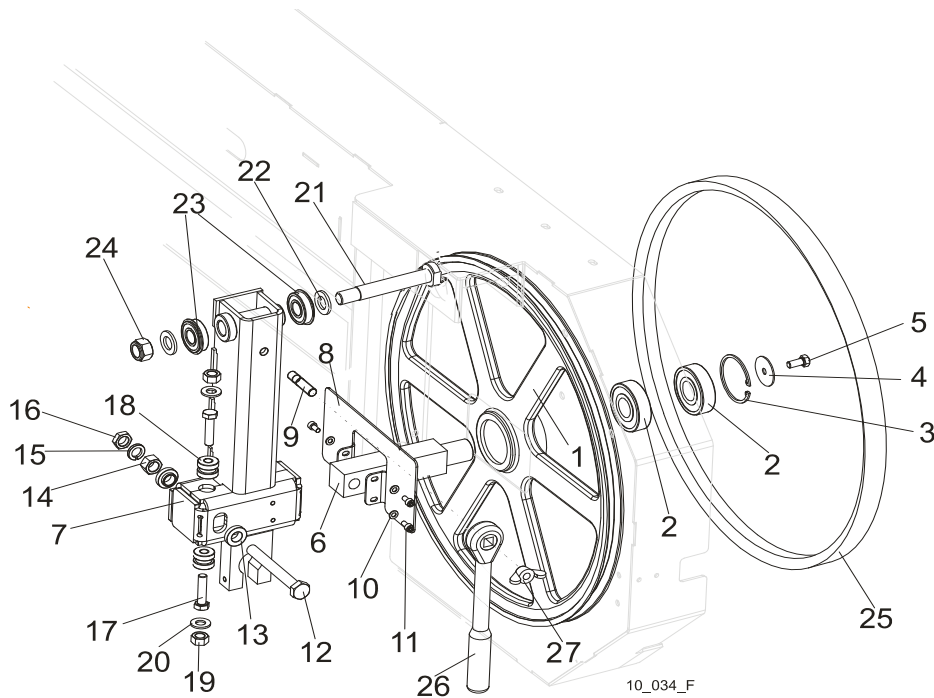

REF.	DESCRIPTION (◆ Indicates Parts Available In Assemblies Only)	PART #	QTY
	WHEEL ASSEMBLY, IDLE SIDE BLADE	A08218	1
1	WHEEL ASSEMBLY, 18.62" BLADE IDLE SIDE	P08125	1
2	BEARING, 6305 2RS NSK IDLE SIDE WHEEL	P08066	2
3	RING, 2 7/16" INSIDE RETAINING	F04254-21	1
	HOUSING, LT10 & LT15 IDLER SHAFT, COMPLETE	100180	1
4	WASHER, IDLE SIDE WHEEL RETAINING	093854-1	1
5	BOLT, M8X25-8.8-B HEX HEAD FULL THREAD ZINC	F81002-5	1
6	SHAFT, IDLE SIDE BLADE WHEEL (METRIC)	096045	1
	HOUSING, IDLER SHAFT COMPLETE	508145	1
7	HOUSING, IDLER SHAFT WELDED/PAINTED	508144-1	1
8	COVER, HOUSING, IDLER SHAFT COMPLETE PAINTED	508128-1	1
9	BOLT M10X35-8.8	F81003-9	1
10	WASHER, 5.3 FLAT ZINC	F81052-1	3
11	SCREW, M5x10 DIN912 A2-70 HEX SOCKET HEAD	F81000-23	3
12	BOLT, M12X1,25X100-8.8 HEX HEAD FULL THREAD ZINC	F81004-41	1
13	WASHER, FLANGED ZINC-PLATED	086769-1	2
14	NUT, M12X1,25 -8 HEX ZINC	F81034-8	1
15	WASHER, 12.2 SPLIT LOCK ZINC	F81056-2	1
16	NUT, M12x1.25 DIN439 THIN STAINLESS STEEL	F81034-5	1
17	BOLT, M10 X 40-8.8 Fe/Zn5, PN-M/82105	F81003-16	2
18	BUSHING, M10 IDLER SHAFT HOUSING	086987	2
19	NUT, M10-8-B HEX HEAD ZINC	F81033-3	2
20	WASHER, 10.5 FLAT ZINC	F81055-1	2
21	PIN, IDLER ARM MOUNT	086404	1
22	WASHER, 17 FLAT ZINC	F81058-1	2
23	BEARING, 6203-2RS NR NSK W/SNAP RING	086395	2
24	NUT, M16-8 HEX NYLON ZINC LOCK	F81036-2	1

4**Blade Wheels & Tensioner***Blade Wheel Assembly, Idle Side*

25	V-BELT, B57	P04185-2	1	
26	WRENCH, BLADE TENSION	091620	1	
27	NUT, M10 WING	F81033-8	1	

4.4 Blade Tensioner Assembly

510640_001
510640_MANUAL

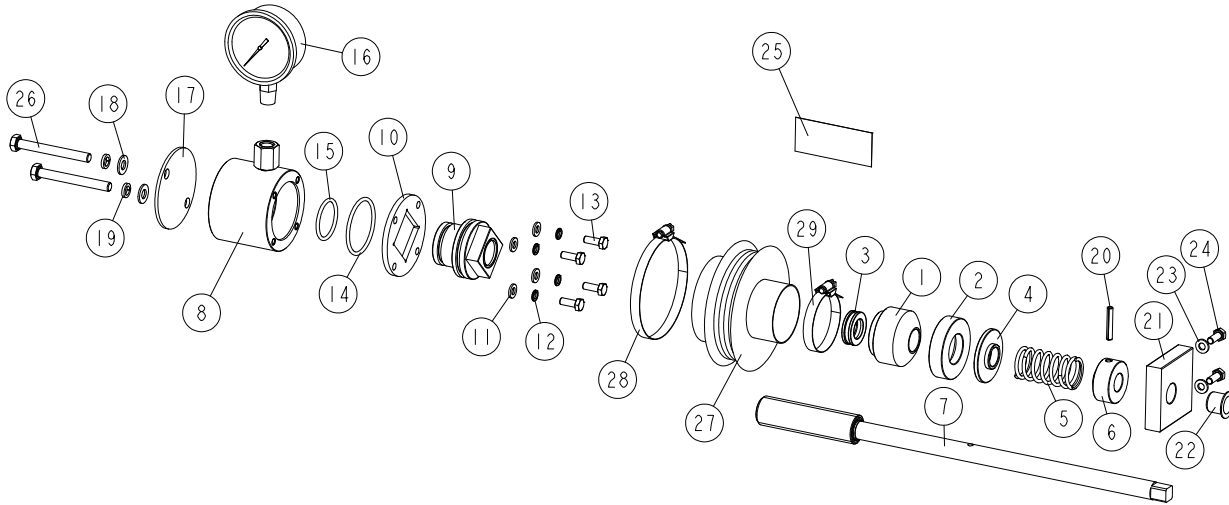

REF	DESCRIPTION (u indicates parts available in assemblies only)	PART #	QTY
-	COMPLETE BLADE TENSIONER	510640	1
1	HOUSING, BALL THRUST BEARING	510635	1
2	SOCKET, BEARING HOUSING	510634-1	1
3	BEARING, 51103. BALL THRUST	086675	1
4	WASHER	510633-1	1
5	SPRING, 60X23X3	088992	1
6	BUSHING, BLADE TENSIONER SCREW	510636-1	1
7	SCREW, BLADE TENSIONER ZINC-PLATED	510650-1	1
-	CYLINDER ASSEMBLY	510641	1
8	CYLINDER ASSEMBLY WITH REDUCTION	550762-1	1
9	PISTON	510638	1
10	PLATE, CYLINDER	510490-1	1
11	WASHER, 6.4 FLAT ZINC	F81053-1	4
12	WASHER, Z 6.1 SPLIT LOCK	F81053-3	4
13	BOLT, M6X16-5.8 HEX HEAD FULL THREAD ZIN	F81001-15	4
14	O-RING, 46.2X3	510646	1
15	O-RING, 32.2X3	510647	1
16	GAUGE, 3000PSI/200 BAR OIL PRESSURE	505176	1
17	COVER, TENSIONER	550761-1	1
18	WASHER, 8.4 FLAT ZINC	F81054-1	2
19	WASHER 8,2 SPLIT LOCK ZINC	F81054-4	2
20	PIN 5X30 ROLL	F81044-21	1
21	BLOCK, TENSIONER HANDLE MOUNT	096730	1
22	BUSHING, GFM-1618-17	089589	1
23	WASHER, 6.4 FLAT ZINC	F81053-1	2
24	BOLT, M6X16-5.8 HEX HEAD FULL THREAD ZIN	F81001-15	2
25	DECAL, BLADE TENSION INDICATOR ADJUSTMEN	510643	1
26	BOLT, M8X70-8.8 HEX HEAD ZINC	F81002-71	2
-	BELLOWS, COMPLETE	515050	1
27	BELLOWS	515051	1

4**Blade Wheels & Tensioner***Blade Tensioner Assembly*

REF	DESCRIPTION (u indicates parts available in assemblies only)	PART #	QTY	
28	CLAMP, 70-80MM DIA.	F81095-5	1	
29	CLAMP, 40-60MM DIA.	F81095-4	1	

4.5 Motor Assembly

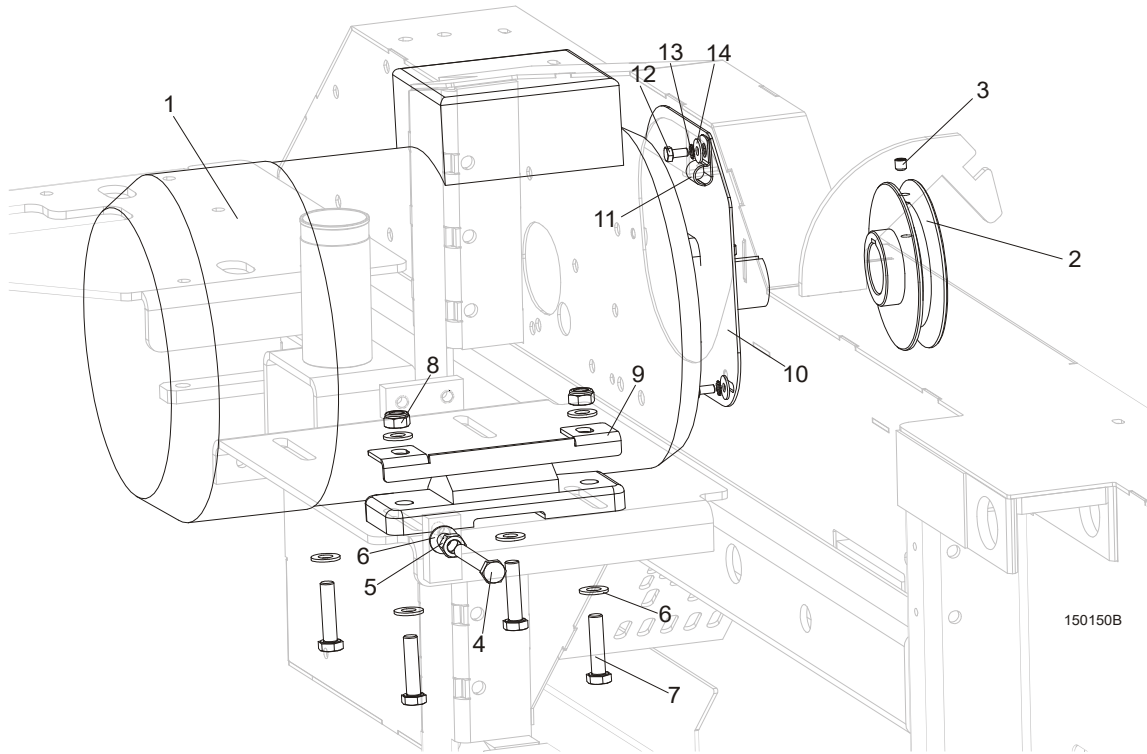

REF.	DESCRIPTION (◆ Indicates Parts Available In Assemblies Only)	PART #	QTY
1	MOTOR, 7.5KW (11HP) 380-420V 50HZ ELECTRIC	085482 ¹	1
2	PULLEY, LT15 E11 MOTOR ZINC-PLATED	086807-1 ²	1
3	SCREW, M8X8-33H HEX SOCKET SET FLAT POINT ZINC	F81014-1	1
4	BOLT, M10X80-8.8 HEX HEAD FULL THREAD ZINC	F81003-76	2
5	NUT, M10-8-B HEX ZINC	F81033-3	2
6	WASHER, 10.5 FLAT ZINC	F81055-1	10
7	BOLT, M10X45-8.8 HEX HEAD FULL THREAD ZINC	F81003-3	4
8	NUT, M10-8-B HEX NYLON ZINC LOCK	F81033-1	4
9	HANDLE, E11 MOTOR	100760-1	1
10	MOTOR SHAFT COVER, E11/E15	086787	1
11	CLAMP, 1/2" EMT COATED	P07584	1
12	BOLT M6X12-8.8-FE/ZN5	F81001-7	3
13	WASHER, M6 STAR LOCK ZINC	F81053-2	3
14	WASHER, 6.5 SPECIAL FLAT ZINC	F81053-11	3

¹ LT15 for the Russian market is equipped with motor No. 095005R

² LT15 for the Russian market is equipped with motor pulley No. 091560-1

SECTION 5 SAW HEAD

5.1 Blade Housing Cover

LT15SCS3G19SP-ESWP_002
LT15SCS3G19SP-ESWP_MANUAL

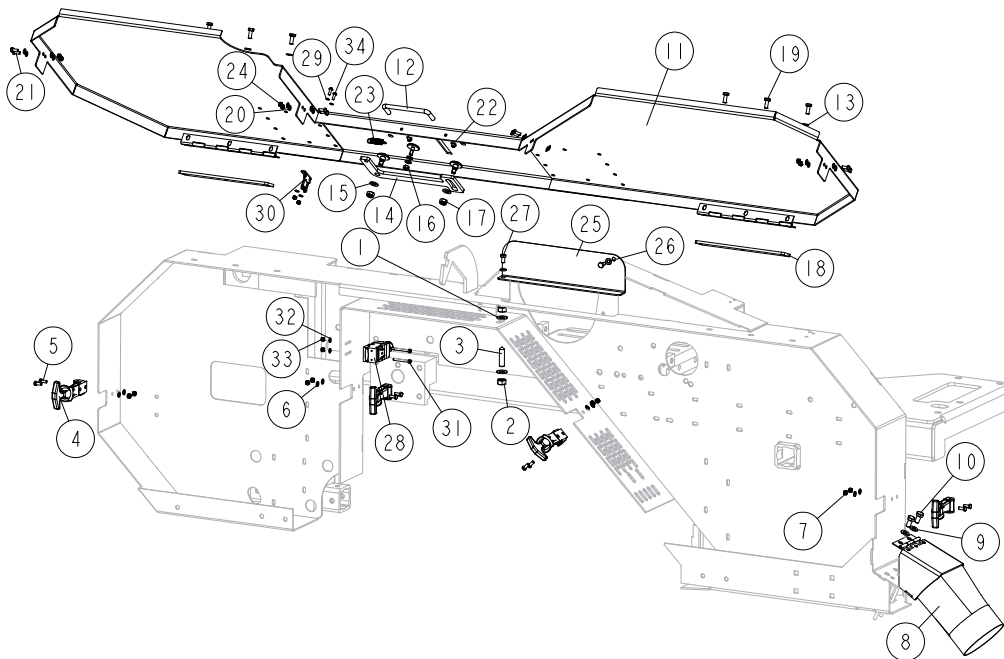

REF	DESCRIPTION (u indicates parts available in assemblies only)	PART #	QTY
1	WASHER, 10.5 FLAT ZINC	F81055-1	2
2	NUT, M10-8-B-HEX ZINC	F81033-3	2
3	SCREW, M10 X 40-45H HEX SOCKET SET CONE	F81003-61	1
4	LATCH, FLEXIBLE DRAW	014829	4
5	BOLT, M5X12 8.8 HEX HEAD FULL THREAD ZIN	F81000-5	8
6	WASHER, 5.3 FLAT ZINC	F81052-1	8
7	NUT, M5-8 DIN985 ZINC-PLATED	F81030-2	8
8	CHUTE WELDMENT, SAWDUST	100903-1	1
9	WASHER, 8.4 FLAT ZINC	F81054-1	2
10	BOLT, M8X16 -8.8-B HEX HEAD FULL THREAD	F81002-20	2
-	COVER, LT15 FRONT COMPLETE	098678	1
11	COVER WELDMENT, LT20 BLADE HOUSING	096776-1	1
12	HANDLE, BLADE HOUSING COVER	P08065	1
13	WASHER, 6.4 FLAT ZINC	F81053-1	8
14	PAWL, LOCKING	090643-1	1
15	WASHER, 8.4 FLAT ZINC	F81054-1	2
16	NUT, M6-8-B HEX NYLON ZINC LOCK	F81031-2	1
17	NUT, M8-8-B HEX NYLON ZINC LOCK	F81032-2	2
18	PLATE WELDMENT, COVER MOUNT	086701-1	1
19	BOLT, M6X16-5.8 HEX HEAD FULL THREAD ZIN	F81001-15	6
20	WASHER, 5.3 FLAT ZINC	F81052-1	16

REF	DESCRIPTION (u indicates parts available in assemblies only)	PART #	QTY	
21	BOLT, M5X12 8.8 HEX HEAD FULL THREAD ZIN	F81000-5	8	
22	SCREW, #8-32X3/8, SELF-TAPPING	F05015-8	2	
23	SPRING, 1.6X12X38 EXTENSION	092208	1	
24	NUT, M5-8 DIN985 ZINC-PLATED	F81030-2	6	
25	COVER, SAW HEAD MOUNT	096788-1	1	
26	WASHER, 6.4 FLAT ZINC	F81053-1	2	
27	BOLT, M6X12-8.8 HEX HEAD FULL THREAD ZIN	F81001-7	2	
28	SWITCH, AZ17-11ZRK SAFETY 1	094232	1	
29	KEY, AZ17/170-B5 SAFETY SWITCH 2	094422	1	
30	KEY, AZ17/170-B5 SAFETY SWITCH 2	094422	1	
31	SCREW, M4X35 8.8 HEX SOCKET HEAD CAP ZIN	F81011-34	2	
32	WASHER, 4.3 FLAT ZINC	F81051-2	2	
33	NUT, M4-8 HEX NYLON ZINC LOCK	F81029-1	4	
34	SCREW, M4X12 5,8-B CROSS RECESSED PAN HE	F81011-43	2	

5.2 Water Lube Assembly

550787_003_LTI5SC
550787_MANUAL

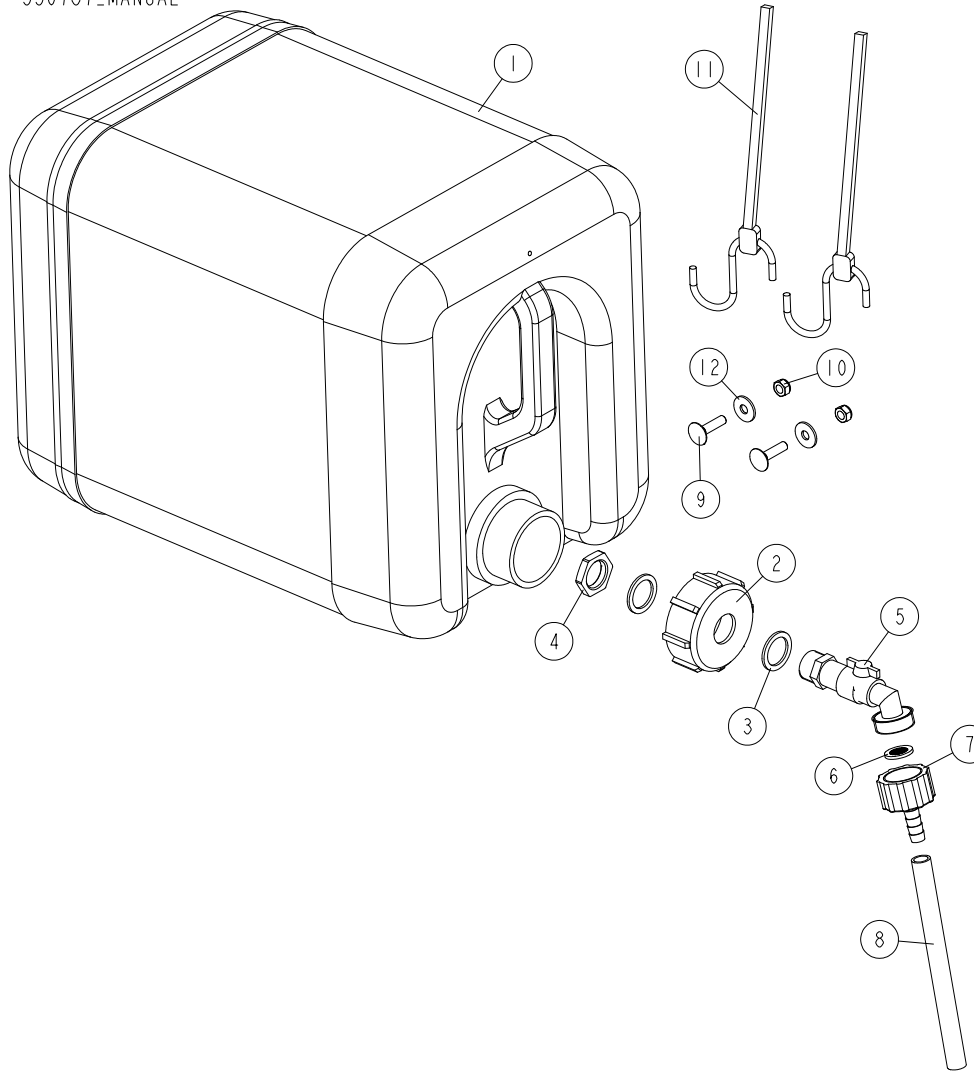

REF	DESCRIPTION (u indicates parts available in assemblies only)	PART #	QTY
-	TANK, OIL	550787	1
1	BOTTLE, WATER	513866	1
2	NUT, BOTTLE	550785	1
3	SEAL, 27X20X1.5 ESSENTA 467673 RUBBER	550780	2
4	NUT, 1/2 ESSENTA 467615 GLAND	550779	1
5	FITTING, WATER LUBE SHUTOFF VALVE	550776	1
6	FILTER, WATER LUBE	550778	1
7	FITTING, G3/4" X 10MM HOSE BARB	550777	1
8	TUBING, WATER LUBE 3/8" I.D.	R01885	1
9	BOLT, M6X25-8.8 ZINC	F81001-20	2
10	NUT, M6-8-B HEX NYLON ZINC LOCK	F81031-2	2
11	STRAP, 24" RUBBER (FOR FUEL TANK - SEE E	P11258	2
12	WASHER, FLAT ZINC	F81053-11	2

5.3 Blade Lube System (not available in EC version)

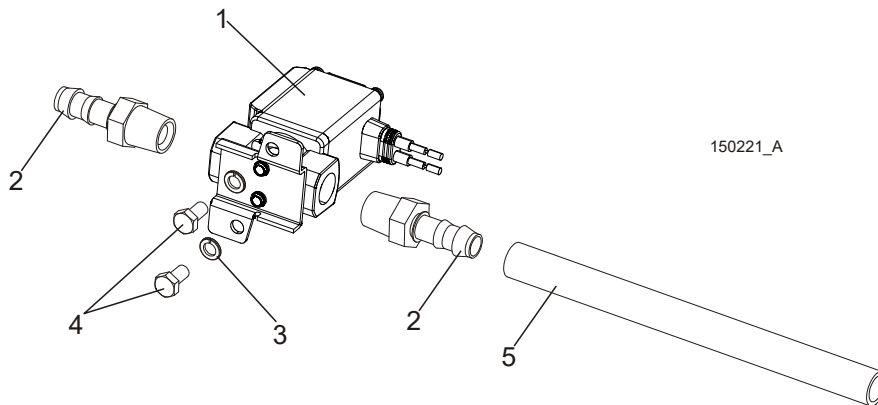

REF.	DESCRIPTION (◆ Indicates Parts Available In Assemblies Only)	PART #	QTY
	KIT, LT15AC BLADE LUBE SYSTEM	503470-S	1
1	SOLENOID, WATER LUBE	509113	1
2	FITTING, 3/8 BARB 1/4NPT MALE NYLON	P04682	2
3	WASHER, M5 SPLIT LOCK	F81052-2	2
4	SCREW, 10-32X1/2 HH MACHINE	F05004-60	2
5	TUBING, WATER LUBE	R01885	3.8m
	CONNECTOR, 16-14GA FI BUTT	F04875-1	2
	CONDUIT, 1/2IN EXPANDABLE BLACK	R02374	0.6m
	BLOCK, LADN11 AUXILIARY CONTACT	084122	1
	ELEMENT, SELF - ADHESIVE MOUNT E9S	087695	2
	CABLE TIE, PLASTIC	F81082-4	3
	GROMMET, 22mm RUBBER	087400	1
	CABLE, 1 SQ MM BLUE	R80583-1	1.5m
	CONDUCTOR END, EL.Hix1/6	F81083-3	4

5.4 LT15AC Saw Head Decals

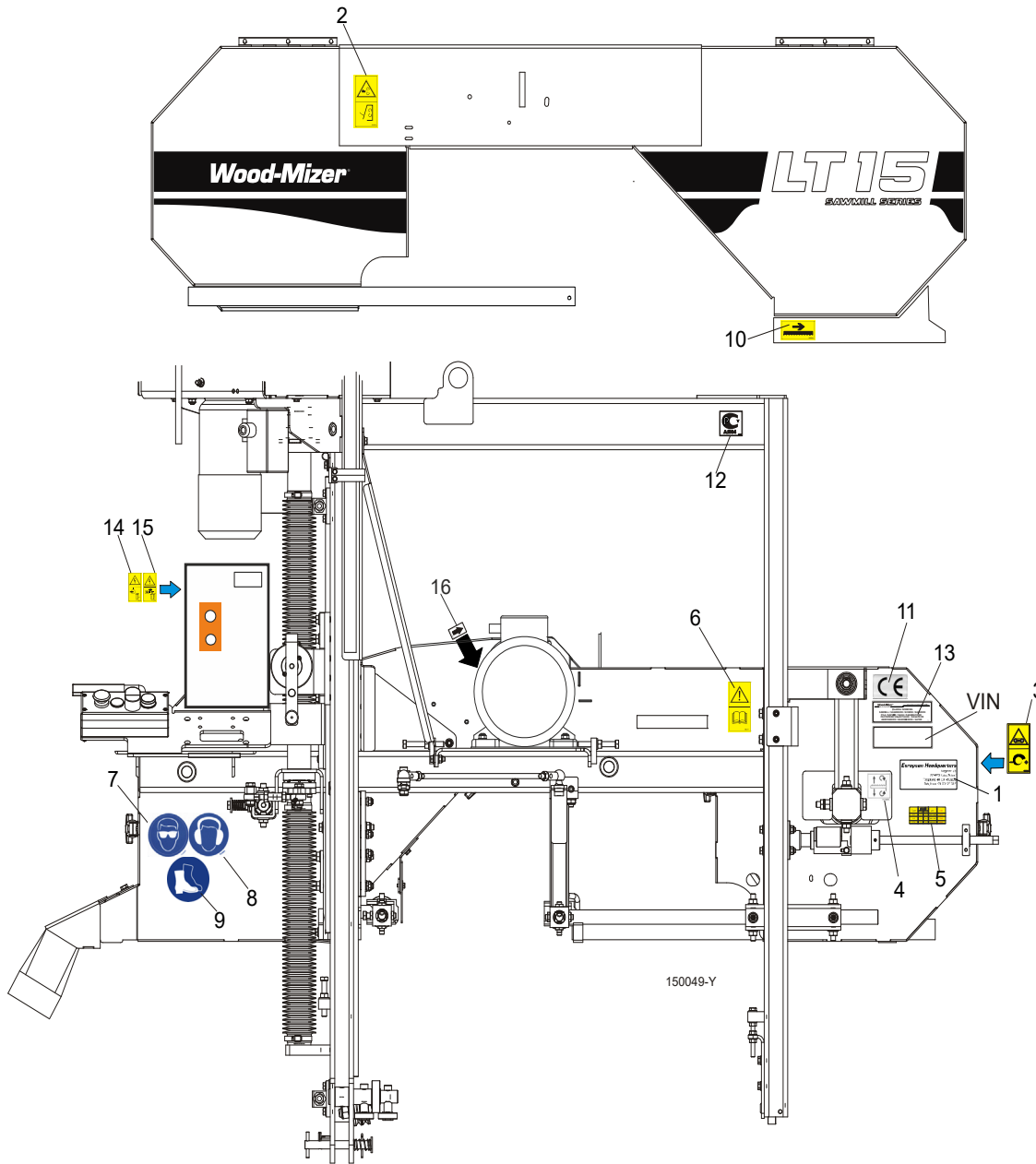

REF.	DESCRIPTION (◆ Indicates Parts Available In Assemblies Only)	PART #	QTY
	PICTOGRAPHIC DECAL KIT, LT15AC	099420	1
	Decal, LT15 Series sawmill	092761	1
1	DECAL, EUROPEAN HEADQUARTERS ADDRESS	015841	1
2	DECAL, SAWMILL COVERS CAUTION	099220	1
3	DECAL, BLADE TENSION (PICTOGRAM)	099219	1
4	DECAL, BLADE ALIGNMENT	P11789	1
5	DECAL, BLADE TENSION INDICATOR ADJUSTMENT	510643	1
6	DECAL, READ OPERATOR'S MANUAL (PICTOGRAM)	096317	1
7	DECAL, EYE PROTECTION WARNING (PICTOGRAM)	S12004G	1
8	DECAL, EAR PROTECTION WARNING (PICTOGRAM)	S12005G	1
9	DECAL, USE SAFETY BOOTS (PICTOGRAM)	501465	1

10	DECAL, BLADE MOVEMENT DIRECTION (PICTOGRAM)	096321	1	
11	DECAL, CE CERTIFIED SAWMILL (SMALL)	P85070	1	
12	DECAL, RUSSIAN SAFETY CERTIFICATION	099401	1	
13	DECAL, INTERNATIONAL SAWMILL NAME	501466	1	
14	DECAL, HIGH VOLTAGE INSIDE THE ELECTRIC BOX (PICTOGRAM)	096316	1	
15	DECAL, REMOVE THE PLUG BEFORE OPENING THE BOX (PICTOGRAM)	096319	1	
16	DECAL, MOTOR REVOLUTIONS DIRECTION	S20097	1	

5.5 Control Box

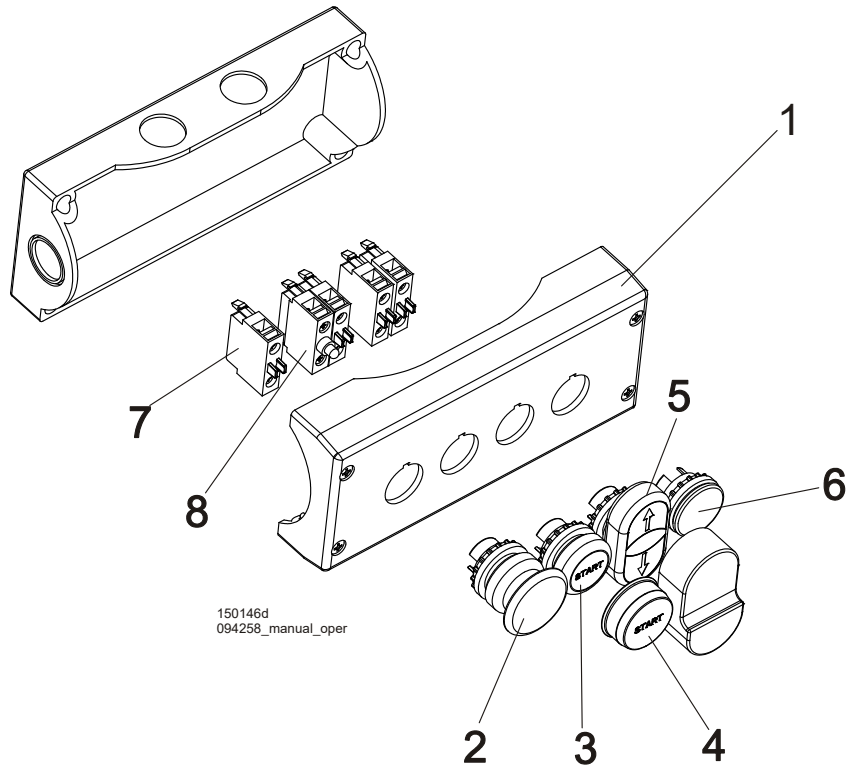

REF.	DESCRIPTION (◆ Indicates Parts Available In Assemblies Only)	PART #	QTY
	BOX, LT15 COMPLETE UP/DOWN CONTROL	094258	1
1	HOUSING, CONTROL PANEL	094259	1
2	BUTTON, M22 MOMENTARY MUSHROOM GREEN	094328	1
3	BUTTON, GREEN ILLUMINATED START	094315	1
4	DIAPHRAGM, M22-T-D	094316	1
5	BUTTON, M22-DD-S-X7/X7	090917	1
6	CAP, M22 - B (216388)	093748	1
7	ELEMENT, M22-KC10 CONTACT	094314	4
8	ELEMENT, LED M22-LEDC-G (AC)	099921	1

5.6 Electrical Box

094237-P_001
094237-P_MANUAL

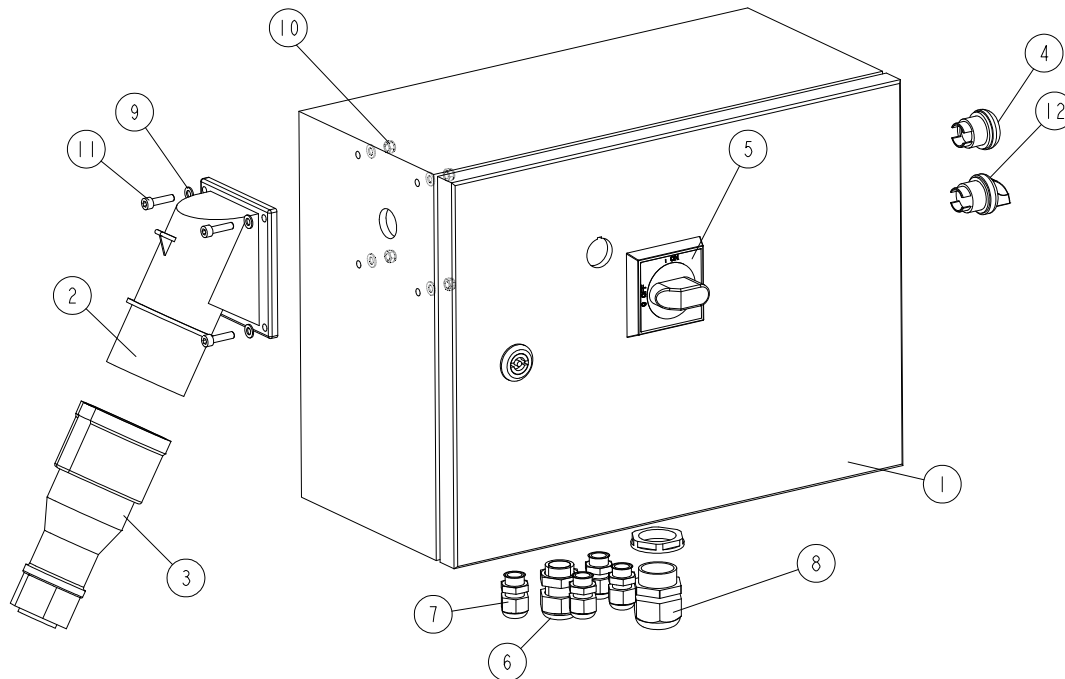

REF.	DESCRIPTION (◆ Indicates Parts Available In Assemblies Only)	PART #	QTY
-	ELECTRICAL BOX, EH10 FOR LT15SC	094237-P	1
	ELECTRICAL BOX, LT15AC - NORWAY	094237-P2	1
	ELECTRICAL BOX, LT15AC - RSA	094237-P3	1
	ELECTRICAL BOX, LT15AC - RUSSIA	094237-R	1
	ELECTRICAL BOX, LT15E15	505376	1
1	BOX, ELECTRICAL (400X300X200)	502689	1
2	PLUG, 16A 5P 778152-6 PCE POWER SUPPLY	E85239	1
3	SOCKET, 16A 5P 2152-6TT PCE POWER SUPPLY	E85240	1
4	LIGHT, M22 LED 24V BLUE CONTROL	536919	1
5	HANDLE, OHB S2A1 AB SELRCTOR	535522-1	1
6	GLAND, DP16/H CABLE	F81096-7	1
7	GLAND, DP9/H CABLE	F81096-2	4
8	GLAND, DP21/H CABLE	F81096-3	1
9	WASHER, 5.3 FLAT ZINC	F81052-1	8
10	NUT, M5-8-FE/ZN5 DIN985	F81030-2	4
11	SCREW, M5X20 8.8 HEX SOCKET HEAD CAP ZINC	F81000-72	4
12	SWITCH, M22-WRK	536902	1

5.7 Mounting Brackets of the Electric Box (230V Version Only)

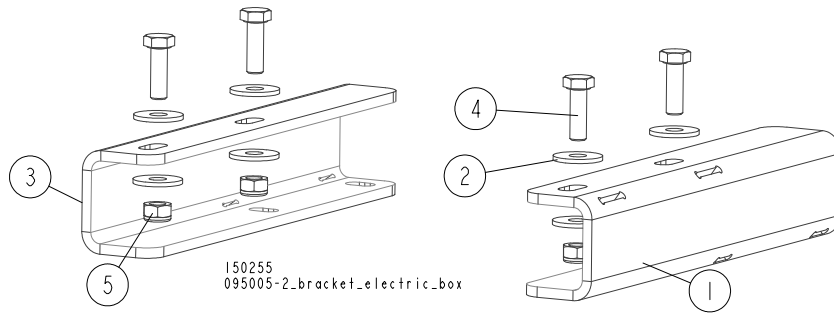

REF.	DESCRIPTION (◆ Indicates Parts Available In Assemblies Only)	PART #	QTY	
1	BRACKET, RIGHT	524186-1	1	
2	WASHER, 8.5 SPECIAL FLAT ZINC	F81054-11	8	
3	BRACKET, LEFT	524187-1	1	
4	BOLT, M8X25-8.8-B HEX HEAD FULL THREAD	F81002-5	4	
5	NUT, M8-8-B HEX NYLON ZINC LOCK	F81032-2	4	

5.8 Control Box - non-CE Version (Part No. 501280)

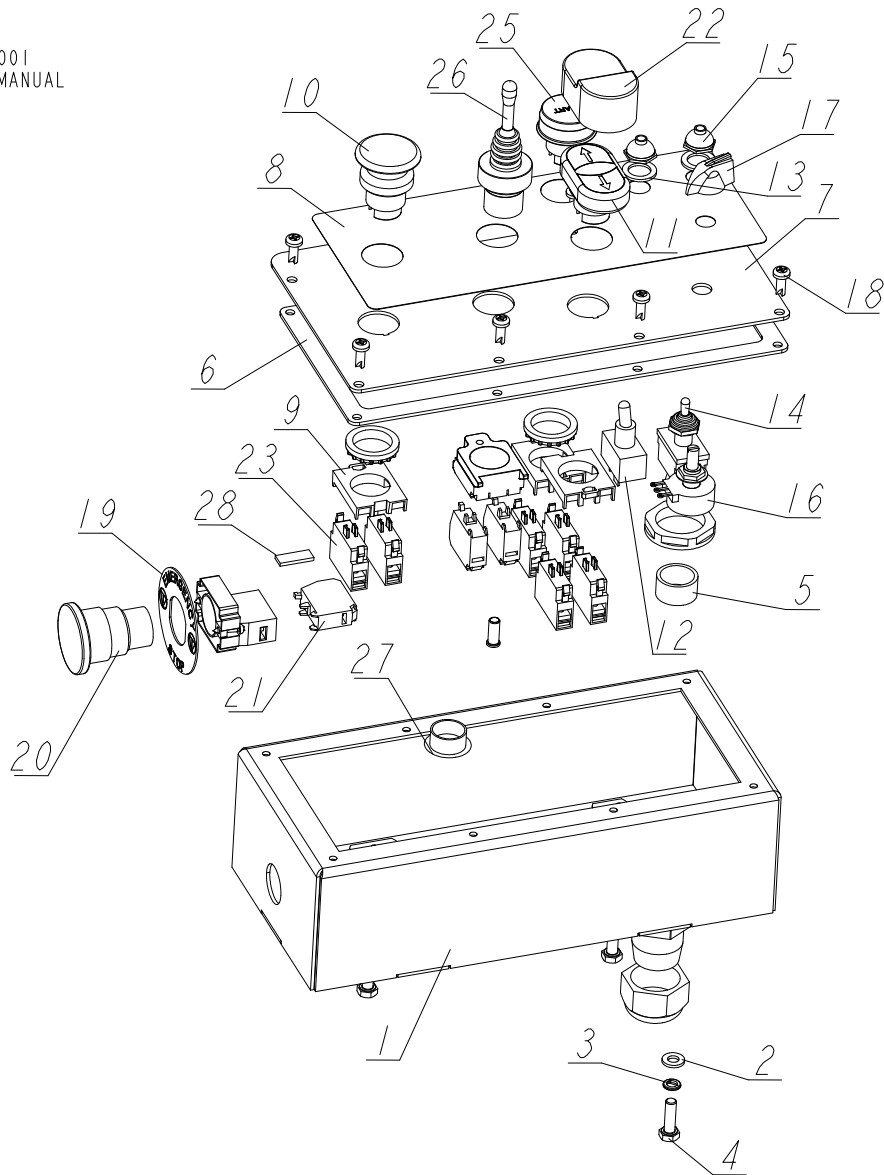
501280_001
501280_MANUAL

REF.	DESCRIPTION (* indicates parts available in assemblies only)	PART NO.	QTY
-	BOX, T15SC/AC CONTROL	501280	1
1	BOX WELDMENT, LT15	501275-1	1
2	WASHER, 6.4 FLAT ZINC	F81053-1	3
3	WASHER, Z 6.1 SPLIT LOCK ZINC	F81053-3	3
4	BOLT, M6X20 8.8 HEX HEAD FULL THREAD ZINC	F81001-2	3
5	GLAND, DP21/H CABLE	F81096-3	1
6	GASKET, LT15 CONTROL BOX	501279	1
7	PLATE, LT15 CONTROL BOX FRONT	501277-1	1
8	DECAL, LT15/AC CONTROL BOX	501281	1
9	ADAPTER, LPXAU120 MOUNTING	535438	3
10	BUTTON, LPCB6143	536909	1
11	BUTTON, LPCBL7191	536908	1
12	SWITCH, TOGGLE	P03027	1
13	WASHER, 1/2X3/4X1/16 NYLON	P05251-1	2

REF.	DESCRIPTION (* indicates parts available in assemblies only)	PART NO.	QTY	
14	SWITCH, TOGGLE 21A DPDT REV MOM SPADE	024200	1	
15	BOOT, TOGGLE SWITCH	P02575	2	
16	POTENTIOMETER,1K,LTAGA	E20519	1	
17	KNOB, SPEED CONTROL	P06257	1	
18	BOLT, #10-24X1/2 PH	F05015-17	8	
19	WASHER, LPX AU115 EMERGENCY STOP BUTTON	536912	1	
20	BUTTON, LPCB6644 EMERGENCY STOP	535445-K	1	
21	CONTACT, 1NCLPXC01	535440	1	
22	BOOT, LPXAU157 BUTTON	536926	1	
23	CONTACT, 1NOLPXC10	535439	2	
24	CONTACT, 1NOLPXC10	535439	4	
25	BUTTON, LPCBL1163	536921	1	
26	JOYSTICK, 8LM2T J200 2-POSITION	536914	1	
27	CAP, SR1086 22.2 HOLE	093544	1	
28	TAPE, MK8 PRINTER BLACK	F81081-34	1	

5.9 Control Box, LT15SC (Part No. 538731)

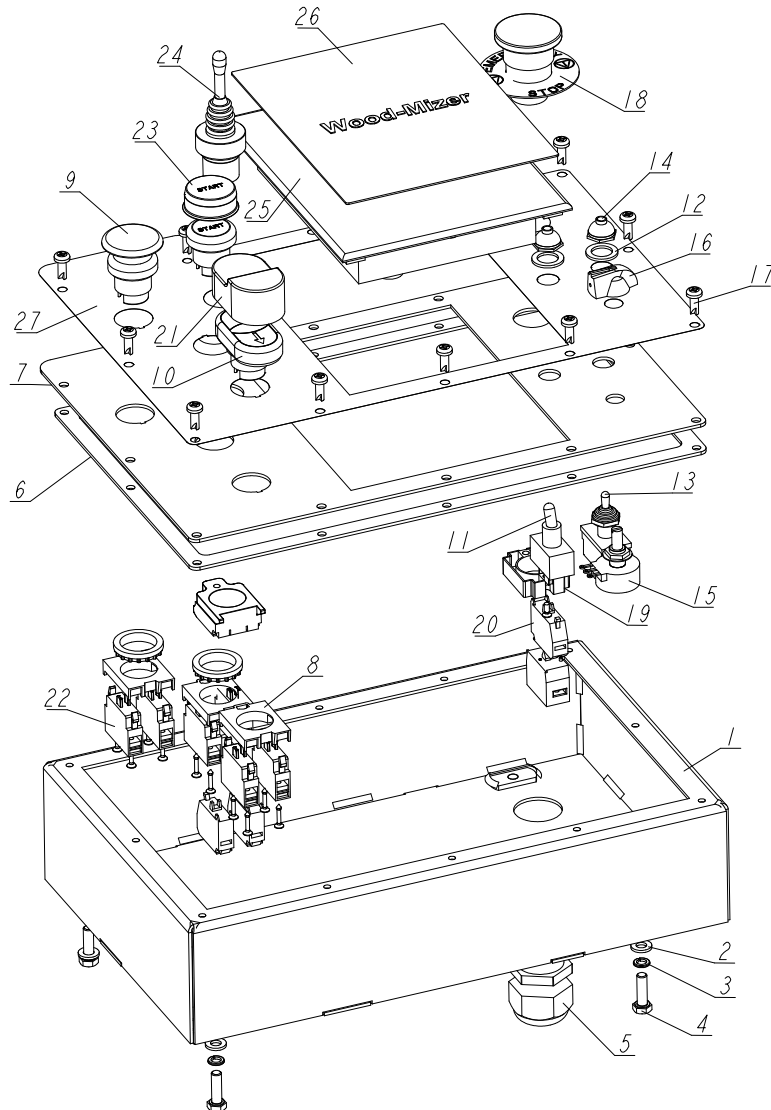
538731_001
538731_MANUAL

REF.	DESCRIPTION (* indicates parts available in assemblies only)	PART NO.	QTY
-	BOX, LT15SC/AC CONTROL	538731	1
1	BOX WELDMENT, LT15 CONTROL	538729-1	1
2	WASHER, 6.4 FLAT ZINC	F81053-1	4
3	WASHER, Z 6.1 SPLIT LOCK	F81053-3	4
4	BOLT, M6X20 8.8 HEX HEAD FULL THREAD ZINC	F81001-2	4
5	GLAND, DP21/H CABLE	F81096-3	1
6	GASKET, LT15 CONTROL BOX	538732	1
7	PANEL, LT15 CONTROL BOX FRONT	538730-1	1
8	ADAPTER, LPXAU120 MOUNTING	535438	3
9	BUTTON, LPCB6143	536909	1
10	SWITCH, LPCBL7191	536908	1
11	SWITCH, TOGGLE	P03027	1
12	WASHER, 1/2X3/4X1/16 NYLON	P05251-1	2

REF.	DESCRIPTION (* indicates parts available in assemblies only)	PART NO.	QTY	
13	SWITCH, TOGGLE 21A DPDT REV MOM SPADE	024200	1	
14	BOOT, TOGGLE SWITCH	P02575	2	
15	POTENTIOMETER,1K,LTAGA	E20519	1	
16	KNOB, SPEED CONTROL	P06257	1	
17	BOLT, #10-24X1/2 PH	F05015-17	12	
18	WASHER, LPX AU115 E-STOP BUTTON	536912	1	
19	BUTTON, LPCB6644 EMERGENCY STOP	535445-K	1	
20	CONTACT, 1NCLPXC01	535440	1	
21	BOOT, LPXAU157 BUTTON	536926	1	
22	CONTACT, 1NOLPXC10	535439	6	
23	BUTTON, LPCBL1163	536921	1	
24	JOYSTICK, BLM 2T J200	536914	1	
-	CAP, CONTROLLER - COMPLETE	527597	1	
25	CAP, CONTROLLER	504378	1	
26	DECAL, CONTROLLER CAP	504381	1	
27	DECAL, CONTROL BOX	538733	1	

SECTION 6 FEED SYSTEM

6.1 Feed Crank Assembly

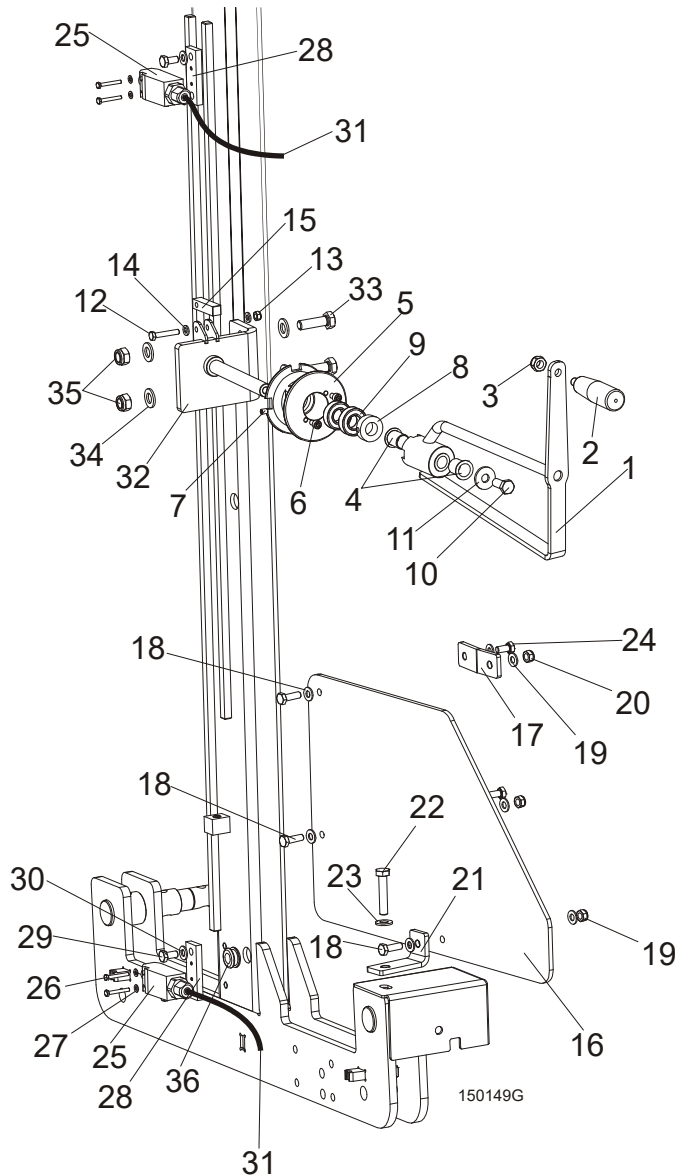

REF.	DESCRIPTION (◆ Indicates Parts Available In Assemblies Only)	PART #	QTY
	MANUAL FEED SYSTEM	094186	1
	Crank Assembly, LT15 Feed	506426	1
1	Crank Weldment, Feed Painted	538949-1	1
2	Knob, 12992M10 Plastic Crank Handle	086338	1
3	Nut, M10-8-B Hex Nylon Zinc Lock	F81033-1	1
4	Bushing, GFM-1719-25	094142	2
5	Pulley, LT15 Feed Rope	086117	1
6	Screw, M6x10-8.8 Hex Socket Head Cap Zinc	F81001-12	2
7	Screw, M6x8 Hex Socket Set Cone Point Zinc	F81013-1	1
8	Ring, 17 Stopping Light Type Zinc-plated	F81039-1	1
9	Bearing, 6003-2RS FAG Rolling	086116	2
10	Bolt, M10x25-8.8 Hex Head Full Thread Zinc	F81003-11	1

6

Feed System

Feed Crank Assembly

11	Washer, 10.5 Special Flat Zinc	F81055-6	1	
12	Bolt, M6x35 8.8 Hex Head Zinc	F81001-71	1	
13	Nut, M6-8-B Hex Nylon Zinc Lock	F81031-2	1	
14	Washer, 6.4 Flat Zinc	F81053-1	2	
15	Pawl, LT15 Detent Zinc-Plated	086156-1	1	
	GUARD, LT15 COMPLETE LOWER	093858	1	
16	Plate, LT15 Lower Guard	093859	1	
17	Bracket, Side Painted	086171-1	2	
18	Bolt, M8x25-8.8-B Hex Head Full Thread Zinc	F81002-5	3	
19	Washer, 8.4 Flat Zinc	F81054-1	6	
20	Nut, M8-8-B Hex Nylon Zinc Lock	F81032-2	3	
21	Bracket, Lower Painted	086172-1	1	
22	BOLT, M10X50-8.8 HEX HEAD FULL THREAD ZINC	F81003-4	1	
23	WASHER, 10.5 FLAT ZINC	F81055-1	1	
24	BOLT, M8X16-8.8-B HEX HEAD FULL THREAD ZINC	F81002-20	1	
	EVN2000C LIMIT SWITCH W/MOUNT PLATE	094227	2	
25	Switch, GLCB01C Limit	100910	1	
26	Bolt, M4x30 8.8 Hex Head Full Thread Zinc	F81000-85	2	
27	Washer, 4.3 Flat Zinc	F81051-2	2	
28	Plate, Limit Switch Mount Painted	094228-1	1	
29	Bolt, M8x16 -8.8-B Hex Head Full Thread Zinc	F81002-20	2	
30	Washer, 8.4 Flat Zinc	F81054-1	2	
31	Cable, OLFLEX 400P 2x1	R80583-5	3m	
32	SUPPORT, LT15 MANUAL FEED SYSTEM	501411-1	1	
33	BOLT, M12X40 8.8 HEX HEAD FULL THREAD ZINC	F81004-4	2	
34	WASHER, 13 FLAT ZINC	F81056-1	4	
35	NUT, M12-8 HEX NYLON ZINC LOCK	F81034-2	2	
36	GROMMET, 20/13 RUBBER	086188	1	

6.2 Track Rail, Rollers & Travel Pins

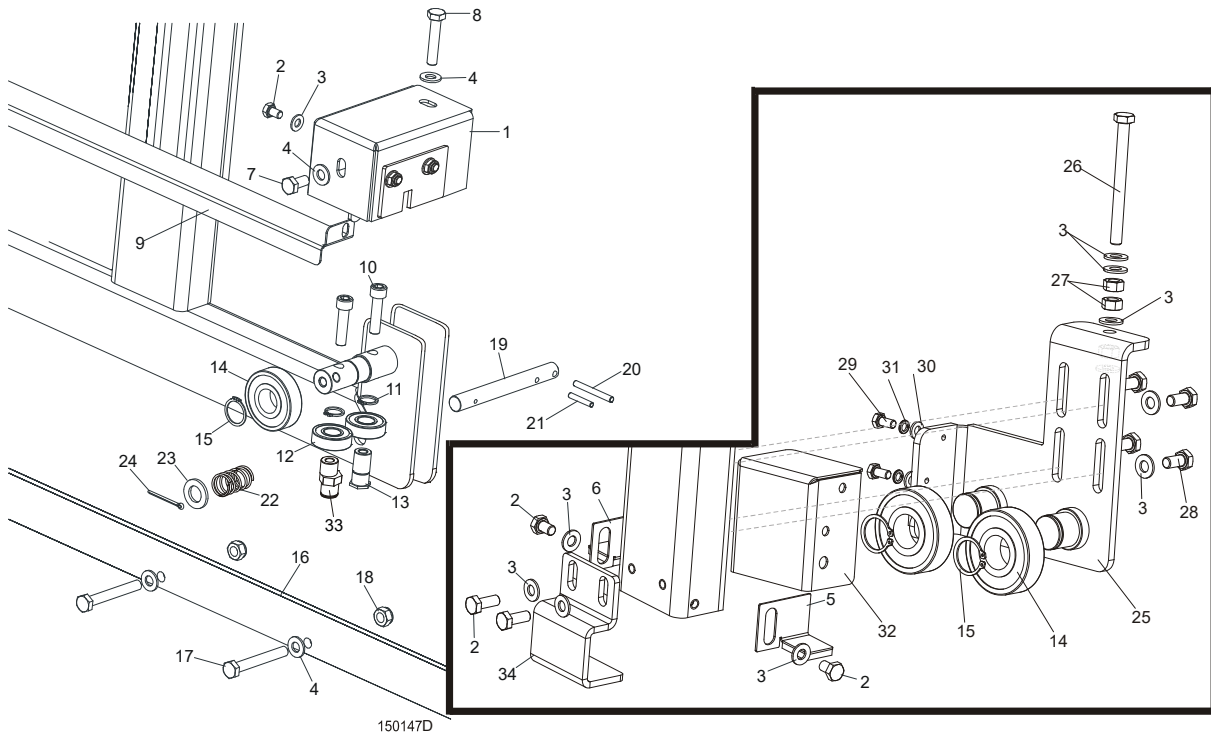

150147D

REF.	DESCRIPTION (◆ Indicates Parts Available In Assemblies Only)	PART #	QTY
1	COVER ASSEMBLY, TRACK ROLLER	542800	2
2	BOLT, M8X12-8.8 HEX HEAD FULL THREAD ZINC	F81002-6	6
3	WASHER, 8.4 FLAT ZINC	F81054-1	14
4	WASHER, 10.5 FLAT ZINC	F81055-1	13
5	PLATE, RIGHT TRACK WIPER	086322	1
6	PLATE, LEFT TRACK WIPER	086323	1
7	BOLT, M10 X 20 5.8 HEX HEAD FULL THREAD ZINC	F81003-1	2
8	BOLT, M10X50-8.8 HEX HEAD FULL THREAD ZINC	F81003-4	2
9	COVER, MIDDLE TRACK	086745	1
10	SCREW, M10X40 HEX SOCKET HEAD CAP ZINC	F81003-22	4
11	RING, Z 17 OUTSIDE RETAINING	F81090-21	4
12	BEARING, 6203-2RS ROLLING	086114	4
13	SHAFT, SIDE BEARING MOUNT ZINC-PLATED	086645-1	2
14	BEARING, 6305-2RS CX	085706	4
15	RING, 25Z OUTSIDE RETAINING	F81090-22	4
16	RAIL, LT15 1950 (LT15S3) TRACK ZINC-PLATED	094427-1	3
	RAIL, LT15 2700 (LT15M2) TRACK ZINC-PLATED	538935-1	2
17	BOLT, M10X75-8.8 HEX HEAD ZINC	F81003-15	9/13 ¹
18	NUT, M10-8-B HEX NYLON ZINC LOCK	F81033-1	9/13 ²
19	PIN, TRAVEL LOCK ZINC-PLATED	086743-1	1
20	PIN, 6X50 ROLL ZINC	F81045-1	1
21	PIN, 5 X 30 ROLL ZINC	F81044-21	1
22	SPRING, 18X37X1.8 COMPRESSION ZINC-PLATED	087301	1

23	WASHER, 17 FLAT ZINC	F81058-1	1	
24	PIN, 4 X 25 COTTER ZINC	F81043-2	1	
25	BRACKET, ROLLER	506707-1	1	
26	BOLT, M8X90-8.8 HEX HEAD FULL THREAD ZINC	F81002-16	1	
27	NUT, M8-8-B HEX ZINC	F81032-1	3	
28	BOLT, M8X16-8.8-B HEX HEAD FULL THREAD ZINC	F81002-20	4	
29	BOLT, M6X12 8.8 HEX HEAD FULL THREAD ZINC	F81001-7	2	
30	WASHER, 6.4 FLAT ZINC	F81053-1	2	
31	WASHER, Z 6.1 SPLIT LOCK ZINC	F81053-3	2	
32	COVER, ROLLER	501783-1	1	
33	SHAFT, E=3.3 ECCENTRIC ZINC-PLATED	531678-1	2	
34	GUIDE, LT15 MAST IDLE SIDE PAINTED	086202-1	1	

¹ Number of bolts for one bed section.

² Number of nuts for one bed section.

6.3 Track Roller Cover Assembly

542800_001
542800_MANUAL

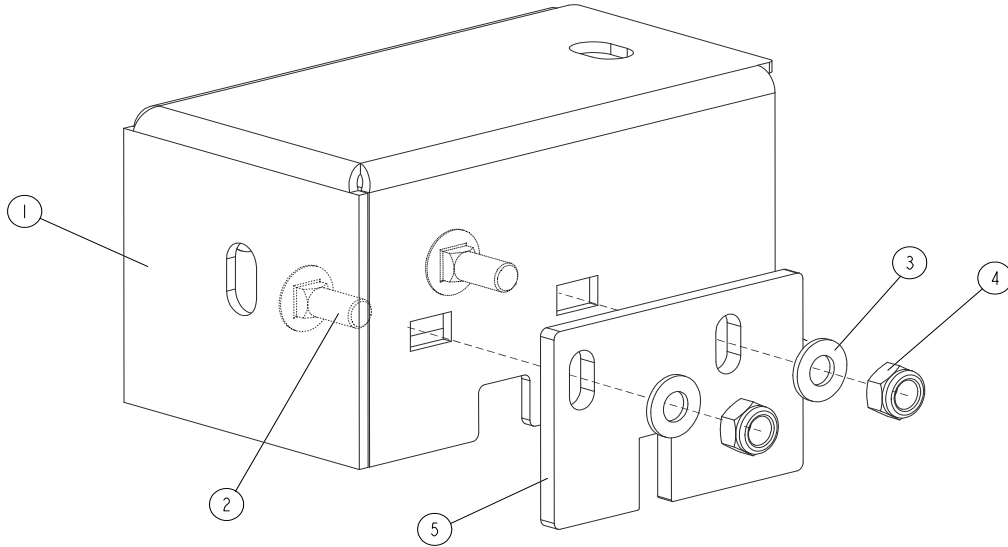

REF.	DESCRIPTION (◆ indicates parts available in assemblies only)	PART #	QTY	
	COVER ASSEMBLY, TRACK ROLLER	542800	2	
1	COVER, TRACK ROLLER	531664-1	1	
2	BOLT, M8x20-8.8 CARRIAGE ZINC	F81002-11	4	
3	WASHER, 8.4 FLAT ZINC	F81054-1	4	
4	NUT, M8-8-B HEX NYLON ZINC LOCK	F81032-2	4	
5	PLATE, TRACK WIPER	531670	2	

6.4 Feed Rope, Rope Guide System & Mount Brackets

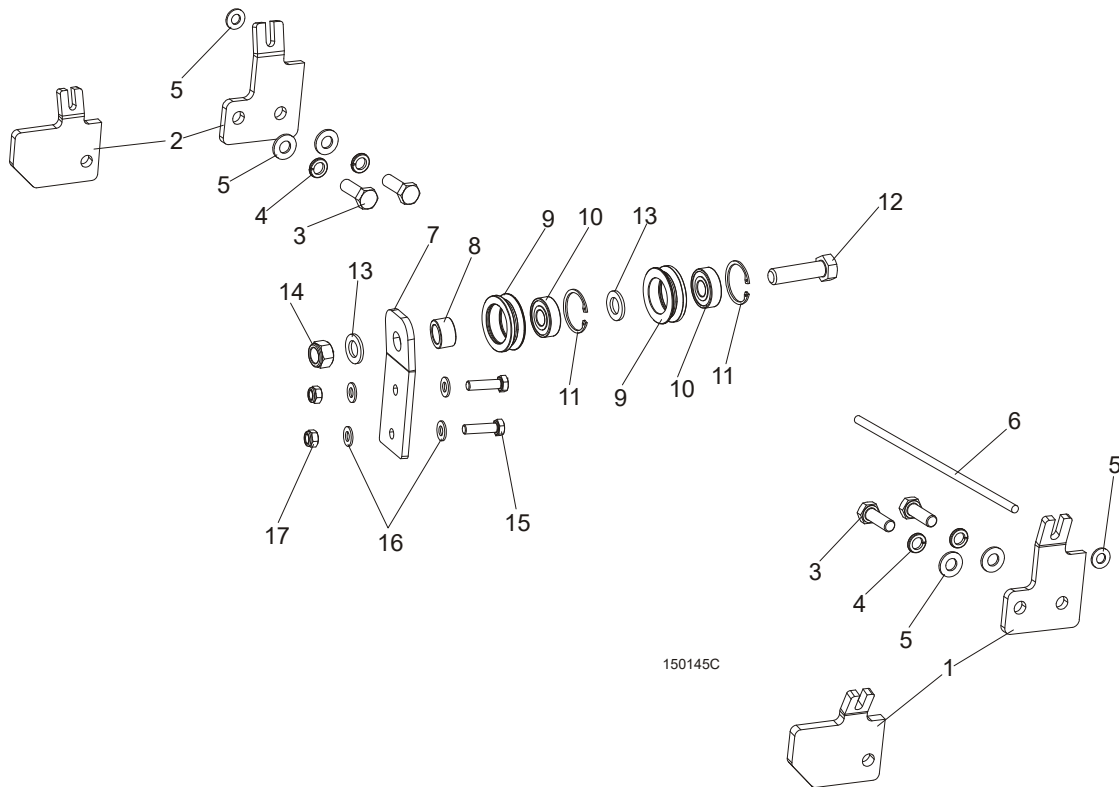

REF.	DESCRIPTION (◆ Indicates Parts Available In Assemblies Only)	PART #	QTY
1	BRACKET, LT15 ROPE MOUNT FRONT	550623-1	1
2	BRACKET, LT15 ROPE MOUNT REAR	550624-1	1
3	BOLT, M10X30-5.8 HEX HEAD FULL THREAD ZINC	F81003-2	4
4	WASHER, 10.2 SPLIT LOCK ZINC	F81055-2	4
5	WASHER, 10.5 FLAT ZINC	F81055-1	6
6	ROPE, 5/16" DIA. BRAIDED POLYESTER	R02080	1
	ROPE ROLLER GUIDE SYSTEM - COMPLETE	502521	1
7	SUPPORT, ROPE ROLLER GUIDE SYSTEM	501955	1
8	SPACER, N25XN16.5X60 BEARING	501415-1	1
	ROLLER ASSEMBLY, V-GROOVE W/BEARING	093855	2
9	ROLLER, V-GROOVE ZINC-PLATED	093856-1	1
10	BEARING, 6203 2RS 5/8 CX	095087	1
11	RING, W40 INSIDE RETAINING	F81090-3	1
12	BOLT, M16X70 8.8 HEX HEAD FULL THREAD ZINC	F81006-16	1
13	WASHER, 17 FLAT ZINC	F81058-1	2
14	NUT, M16-8 HEX NYLON ZINC LOCK	F81036-2	1
15	BOLT, M8X30-8.8 ZINC	F81002-7	2
16	WASHER, 8.4 FLAT ZINC	F81054-1	4
17	NUT, M8-8-B HEX NYLON ZINC LOCK	F81032-2	2
18	MOUNT WELDMENT, CARRIAGE STOP	086182-1	2
19	BUSHING, 11/16X2 1/8X1 3/4 RUBBER	P12165	2
20	PIN, S-ZN 4X45 COTTER ZINC	F81043-21	2

6.5 Power Feed System - Optional

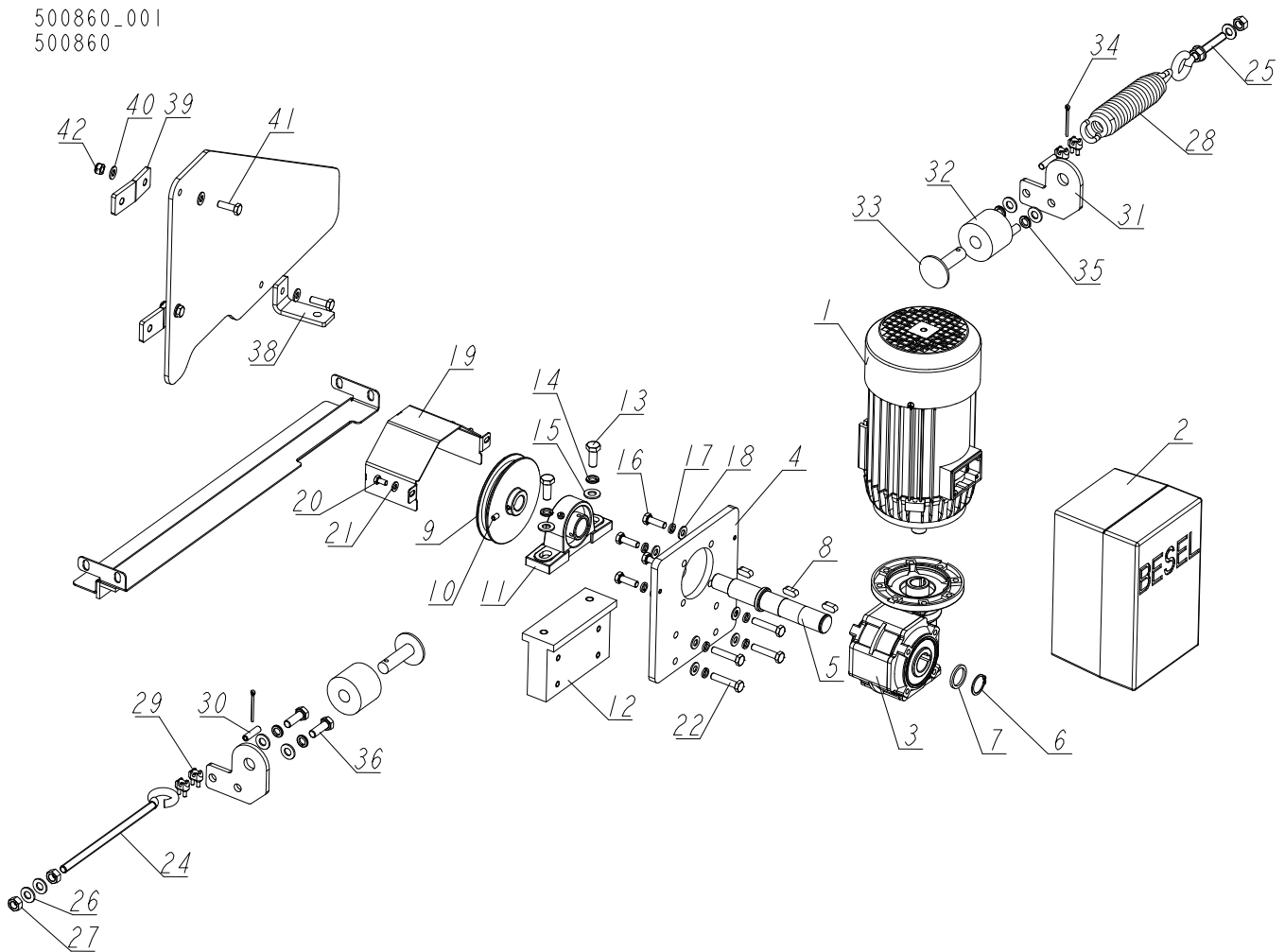

REF.	DESCRIPTION (◆ Indicates Parts Available In Assemblies Only)	PART #	QTY
-	POWER FEED ASSEMBLY, LT15/AC	500860	1
-	POWER FEED ASSEMBLY, LT15/AC BESEL	580824	1
-	KIT, 2SIEK80-4A + OPC-2-140022 + KC50-15	580823	1
1	MOTOR, BESEL 2SIEK80-4A2 0.55KW 1400R.P.M. 3X400V, 50HZ, Y, B14/2, IE2	580827	1
2	AC DRIVE, INVERTEK OPC-2-140022-3F11003E	580825	1
3	REDUCER, TRAMEC KC50-15 PAM 120/19 I=15	580826	1
4	PLATE, MOTOREDUCER MOUNTING	501269-1	1
5	SHAFT, MOTOREDUCER OUTPUT	500862	1
6	RING, 25Z OUTSIDE RETAINING	F81090-22	1
7	WASHER, 25.1/32-3 ZINC-PLATED	500863-1	1
8	KEY, A8X7X20	099059	3
9	PULLEY, LT15 POWER FEED ROPE	500864-1	1
10	SCREW, M6X10-45H HEX SOCKET SET FLAT POINT	F81001-26	1
11	BEARING ASSY, UCP205CX	088468	1
12	CUBE, MOUNTING	501271-1	1
13	BOLT, M10X25 8.8 HEX HEAD FULL THREAD ZINC	F81003-11	2

6

Feed System

Power Feed System - Optional

REF.	DESCRIPTION (◆ Indicates Parts Available In Assemblies Only)	PART #	QTY
14	WASHER, Z 10.2 SPLIT LOCK ZINC	F81055-2	2
15	WASHER, 10,5 FLAT ZINC	F81055-1	2
16	BOLT, M8X25-8.8-B-HEX HEAD FULL THREAD ZINC	F81002-5	4
17	WASHER, 8.2 SPLIT LOCK ZINC	F81054-4	8
18	WASHER, 8.4 FLAT ZINC	F81054-1	8
19	COVER, FRONT	500861-1	1
20	BOLT, M6X12 8.8 HEX HEAD FULL THREAD ZINC	F81001-7	2
21	WASHER, 6.4 FLAT ZINC	F81053-1	2
22	BOLT, M8X40-8.8 HEX HEAD FULL THREAD ZINC	F81002-15	4
23	COVER, LT15 TRACK W/FELT STRIP	500839	1
24	TENSIONER, ZINC-PLATED	500846-1	1
25	TENSIONER, SHORT ZINC-PLATED	500848-1	1
26	WASHER, 10,5 FLAT ZINC	F81055-1	8
27	NUT, M10 8 HEX ZINC	F81033-3	4
28	SPRING, PRESS ROLLER ZINC-PLATED	089689-1	1
29	CLAMP, LT20 STRING	091614	4
30	POINTER, STEEL CABLE	501417-1	2
31	PLATE, LT15 POWER FEED SUPPORT	501414-1	2
32	BUSHING, 11/16X2 1/8X1 3/4 RUBBER	P12165	2
33	MOUNT WELDMENT, CARRIAGE STOP PTD	086182-1	2
34	PIN, 4x25 COTTER	F81043-2	2
35	WASHER, Z 10.2 SPLIT LOCK ZINC	F81055-2	4
36	BOLT, M10X30-8.8 HEX HEAD FULL THREAD ZINC	F81003-2	4
-	COVER, LT15 LOWER - COMPLETE	500727	1
37	PLATE, LT15 LOWER COVER	500726	1
38	BRACKET, LT15 LOWER	086172-1	1
39	BRACKET, LT15 SIDE	086171-1	2
40	WASHER, 8.4 FLAT ZINC	F81054-1	6
41	BOLT, M8X25-8.8-B-HEX HEAD FULL THREAD ZINC	F81002-5	3
42	NUT, M8-8-B-HEX NYLON ZINC LOCK	F81032-2	3

6.6 Power Cord Bracket (Part No. 097449)

097449_001
097449_MANUAL

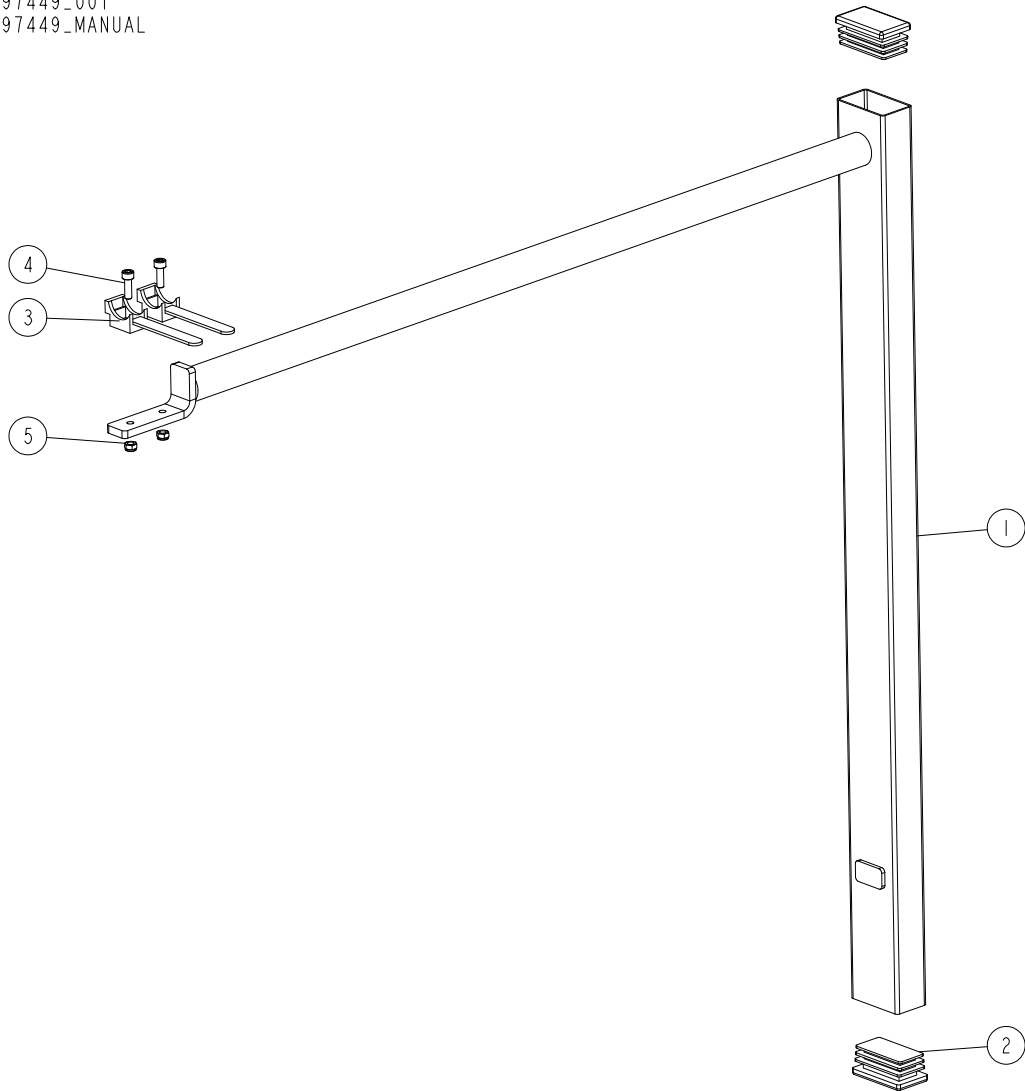

REF.	DESCRIPTION (◆ indicates parts available in assemblies only)	PART #	QTY	
	BRACKET, LT15 POWER CORD COMPLETE	097449	1	
1	BRACKET, LT15 POWER CORD PAINTED	086132-1	1	
2	CAP, 50X30 BLACK	095919	2	
3	HOLDER, UP30 CABLE PLASTIC TIE	F81082-1	2	
4	SCREW, M5X16-8.8 HEX SOCKET HEAD CAP ZINC	F81000-25	2	
5	NUT, M5-8-FE/ZN5 DIN985	F81030-2	2	

SECTION 7 UP/DOWN SYSTEM

7.1 AC Up/Down Drive Assembly

094143_001
 094143

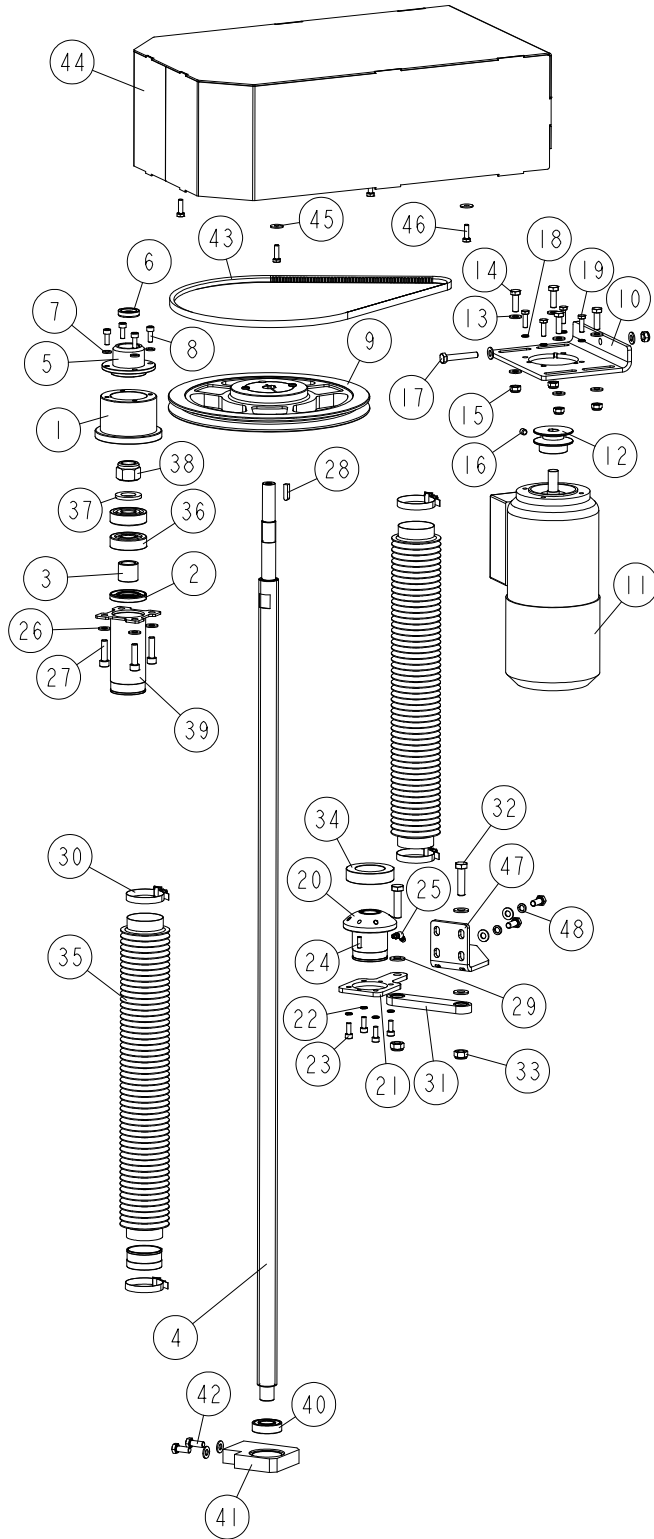

REF	DESCRIPTION (u indicates parts available in assemblies only)	PART #	QTY	
-	DRIVE ASSEMBLY, AC UP/DOWN	094143	1	
1	HOUSING, ACME SCREW BEARING	094164-1	1	
2	RING, AO28X52X7 SEALING	094155	1	
3	BUSHING, 20/28-25 ZINC-PLATED	094156-1	1	
4	SCREW, TR 28X5 ACME	094144	1	
5	COVER, ACME SCREW BEARING HOUSING	094165-1	1	
6	RING, A18X30X7 SEALING	094159	1	
7	WASHER, 6.4 FLAT ZINC	F81053-1	4	
8	SCREW, M6X16 -8.8 HEX SOCKET HEAD CAP ZI	F81001-21	4	
9	PULLEY, SPA 280 X 1 W/18 SPLIT TAPER BUS	094157	1	
-	MOTOR, AC UP/DOWN - COMPLETE	094161	1	
10	PLATE, DRIVE BELT TENSION	094162-1	1	
61	MOTOR, SKH71X-4C2/HPS	093860	1	
	BRAKE, MOTOR	083610	1	
12	PULLEY, UP/DOWN DRIVE	094160-1	1	
13	WASHER, 8.4 FLAT ZINC	F81054-1	10	
14	BOLT, M8X25-8.8-B HEX HEAD FULL THREAD Z	F81002-5	4	
15	NUT, M8-8-B HEX NYLON ZINC LOCK	F81032-2	5	
16	SCREW, M8X8-33H HEX SOCKET SET FLAT POIN	F81014-1	1	
17	BOLT, M8X50 -8.8 HEX HEAD FULL THREAD ZI	F81002-19	1	
18	WASHER, Z 6.1 SPLIT LOCK	F81053-3	4	
19	BOLT, M6X20 8.8 HEX HEAD FULL THREAD ZIN	F81001-2	4	
-	NUT, UP/DOWN DRIVE - COMPLETE	094150	1	
20	NUT, TR28X5 UP/DOWN DRIVE	505315	1	
21	PLATE, NUT HOUSING SEAT	094242-1	1	
22	WASHER, Z 6.1 SPLIT LOCK	F81053-3	4	
23	SCREW, M6X16 -8.8 HEX SOCKET HEAD CAP ZI	F81001-21	4	
24	PIN, 5X16 ROLL ZINC	F81044-3	2	
25	FITTING, M6 "B" TYPE PN-M/86003 GREASE	094213	1	
26	WASHER, 8.4 FLAT ZINC	F81054-1	8	
27	BOLT, M8 X 30-8.8 SOCKET HEAD	F81002-31	4	
28	KEY, 6X6X23	089191	1	
29	WASHER, 10.5 FLAT ZINC	F81055-1	3	
30	CLAMP, 40-60MM DIA.	F81095-4	4	
31	LINK, SBPL 10104 PIVOTAL (COMPLEX)	097700	1	
32	BOLT, M10X40-8.8 HEX HEAD FULL THREAD ZI	F81003-16	2	
33	NUT, M10-8-B HEX NYLON ZINC LOCK	F81033-1	2	
34	WASHER, DIN6319-42-C SPHERICAL SEAT	093864-1	1	
35	BELLOWS, 50/700 PROTECTIVE	094208	2	
36	BEARING, 7304B-UO. ROLLING	094256	2	
37	WASHER, 21 FLAT ZINC	F81059-2	1	
38	NUT, ISO10512-M20X1.5-8-A2 SELF-LOCKING	F81037-5	1	
39	BRACKET, UPPER BELLOWS MOUNT ZINC-PLATED	094221-1	1	
40	BEARING, 6004 2RS CX ROLLING	093868	1	
41	HOUSING, LOWER BEARING (W/LOWER BELLOWS)	093866-1	1	
42	BOLT, M8X20 8.8 HEX HEAD FULL THREAD ZIN	F81002-4	4	
43	V-BELT, AVX-13X1100LA	095306	1	
-	COVER, UP/DOWN DRIVE HIGH - COMPLETE	096948	1	

REF	DESCRIPTION (u indicates parts available in assemblies only)	PART #	QTY	
44	GUARD, LT15 UP/DOWN DRIVE	096945-1	1	
45	WASHER, 6.5 SPECIAL FLAT ZINC	F81053-11	4	
46	BOLT, M6X20 8.8 HEX HEAD FULL THREAD ZIN	F81001-2	4	
47	BRACKET, PIVOTAL LINK MOUNT	511217-1	1	
48	WASHER 8,2 SPLIT LOCK ZINC	F81054-4	2	

7.2 Service Kit, LT15 Up/Down System

512233_001
512233

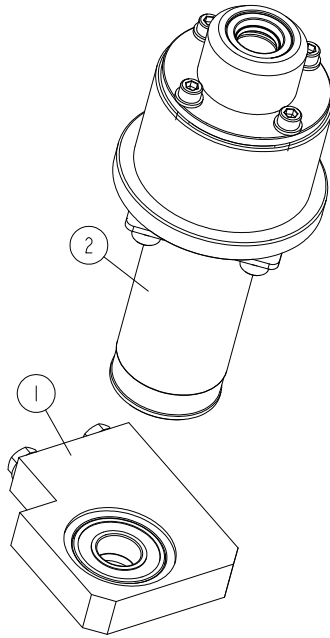

REF.	DESCRIPTION (◆ Indicates Parts Available In Assemblies Only)	PART #	QTY	
	SERVICE KIT, LT15 UP/DOWN SYSTEM	512233	1	
1	SEAT, LOWER BEARING - COMPLETE	512231	1	
2	HOUSING, UP/DOWN BEARINGS	512232	1	

7.3 Slide Pads & Blade Height Scale Indicator

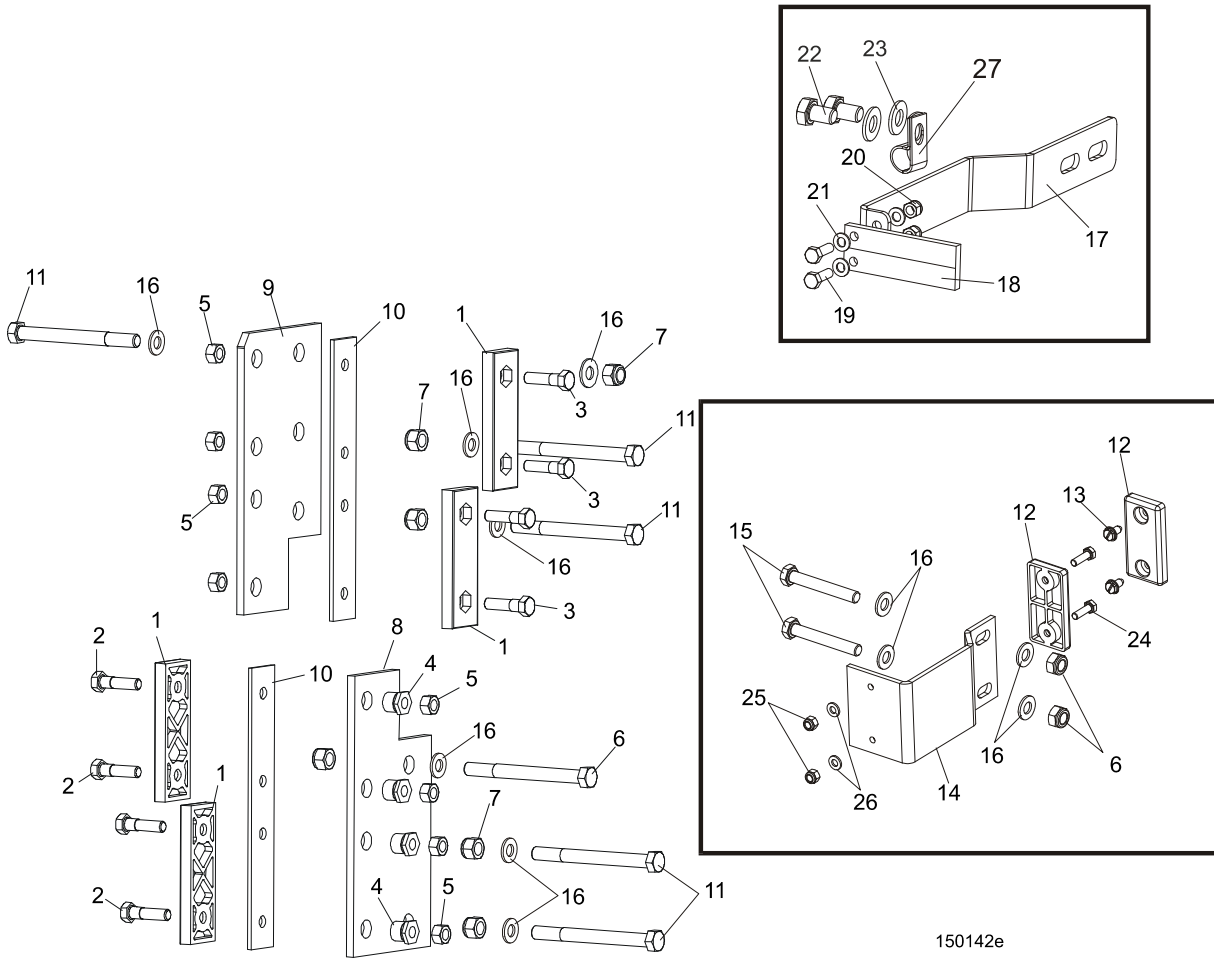

150142e

REF.	DESCRIPTION (◆ Indicates Parts Available In Assemblies Only)	PART #	QTY
1	PADS, DELRIN UP/DOWN SLIDE	M04096	4
2	BOLT, M8X35-8.8 HEX HEAD FULL THREAD ZINC	F81002-13	4
3	BOLT, M8X20-8.8 HEX HEAD FULL THREAD ZINC	F81002-4	4
4	NUT, LT15 SLIDE PAD ADJUSTMENT	086683-1	4
5	NUT, M8-8-B HEX NYLON ZINC LOCK	F81032-2	8
6	BOLT, M10X110 8.8 HEX HEAD ZINC	F81003-43	1
7	NUT, M10-8-B HEX NYLON ZINC LOCK	F81033-1	8
8	PLATE, SAW HEAD LOWER GUIDE PAINTED	086682-1	1
9	PLATE, SAW HEAD UPPER GUIDE PAINTED	094139-1	1
10	PLATE, SLIDE PAD SPACER PAINTED	094140-1	2
11	BOLT, M10X115-8.8 HEX HEAD ZINC	F81003-19	5
12	PAD, IDLE SIDE SLIDE	P13576	2
13	SCREW, 1/4-20 X 1/2" "23" TYPE SELF-TAPPING	F05015-1	2
14	GUIDE, LT15 SAW HEAD PAINTED	087192-1	1
15	BOLT, M10X70-8.8 HEX HEAD FULL THREAD ZINC	F81003-20	2
16	WASHER, 10.5 FLAT ZINC	F81055-1	11
	INDICATOR, BLADE HEIGHT SCALE - COMPLETE (STANDARD)	095967	1

17	Bracket, Scale Indicator Mount	095968-1	1	
18	Indicator, Blade Height Scale	536154	1	
19	Bolt, M5NX16-8.8 Hex Head Full Thread Zinc	F81000-20	2	
20	Nut, M5-8 DIN 985 Zinc-Plated	F81030-2	2	
21	Washer, 5.3 Flat Zinc	F81052-1	4	
22	Bolt, M8x12-8.8 Hex Head Full Thread Zinc	F81002-6	2	
23	Washer, 8.4 Flat Zinc	F81054-1	2	
24	BOLT, M6X20-8.8 HEX HEAD FULL THREAD ZINC	F81001-2	2	
25	NUT, M6-8-B HEX NYLON ZINC LOCK	F81031-2	2	
26	WASHER, 6.4 FLAT ZINC	F81053-1	2	
27	CLAMP, 1/2" EMT COATED	P07584	1	

7.4 Blade Height Scale

538850_001
538850_MANUAL

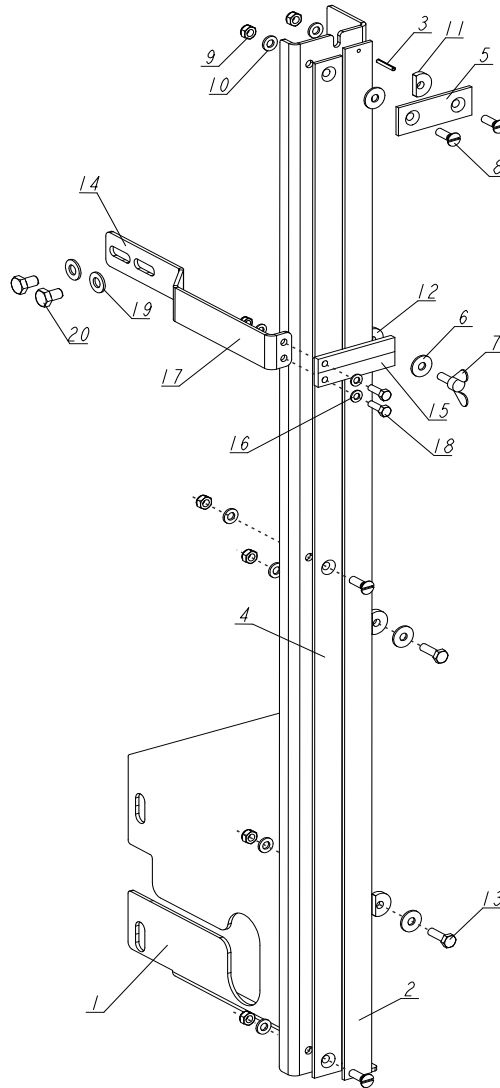

REF.	DESCRIPTION (◆ Indicates Parts Available In Assemblies Only)	PART #	QTY
-	SCALE ASSEMBLY, SC BLADE HEIGHT	538850	1
-	SCALE, METRIC BLADE HEIGHT - COMPLETE	095964	1
1	BRACKET, BLADE HEIGHT SCALE	095965-1	1
2	BAR, INCH SCALE	093133	1
3	PIN, 3X20 GEOMET ROLL	F81044-5	1
4	BAR, SCALE	092750	1
5	BAR, SCALE CLAMP	093134	1
6	WASHER, 6.5 SPECIAL FLAT ZINC	F81053-11	4
7	SCREW, M6X16 FE/ZN5 DIN-316/BN-276 THUMB	F81001-16	1
8	SCREW, M6X20-5.8-B SLOTTED COUNTERSUNK HEAD ZINC	F81001-31	4
9	NUT, M6-8-B HEX NYLON ZINC LOCK	F81031-2	6
10	WASHER, 6.4 FLAT ZINC	F81053-1	6
11	WASHER, 6.2X20X4.5 SPECIAL	503098	3
12	WASHER, 6.2X20X3.5 SPECIAL	503096	1
13	BOLT, M6X20 8.8 HEX HEAD FULL THREAD ZINC	F81001-2	2

-	INDICATOR, BLADE HEIGHT SCALE - COMPLETE	095967	1	
14	BRACKET, INDICATOR MOUNT	095968-1	1	
15	INDICATOR, BLADE HEIGHT SCALE	094821	1	
16	WASHER, 5.3 FLAT ZINC	F81052-1	4	
17	NUT, M5-8-FE/ZN5 DIN985	F81030-2	2	
18	BOLT, M5X16 8.8 HEX HEAD FULL THREAD ZINC	F81000-20	2	
19	WASHER, 8.4 FLAT ZINC	F81054-1	2	
20	BOLT, M8X12-8.8 HEX HEAD FULL THREAD ZINC	F81002-6	2	