

Wood-Mizer[®] Sawmill

Safety, Setup, Operation & Maintenance Manual

LT15S3 E11S

rev. B1.01

LT15M2 E11S

rev. B1.01



Safety is our #1 concern! Read and understand all safety information and instructions before operating, setting up or maintaining this machine.

May 2005

Form #796

This manual is to replace or to be used with all previous information received on the Wood-Mizer®* sawmill. All future mailings will be an addition to or a revision of individual sections of this manual as we obtain new information.

The information and instructions given in this manual do not amend or extend the limited warranties for the equipment given at the time of purchase.

If You Need To Order Parts...

From Europe call our European Headquarters and Manufacturing Facility in Kolo, Poland at **+48-63-2626000** or **+48-3912-1319**. From the continental U.S., call our toll-free Parts hotline at **1-800-448-7881**. Please have the vehicle identification number and your customer number ready when you call. Wood-Mizer will accept these methods of payment:

- Visa, Mastercard, or Select Purchase
- COD
- Prepayment
- Net 15 (with approved credit)

Be aware that shipping and handling charges may apply. Handling charges are based on size and quantity of order. In most cases, items will ship on the day they are ordered. Second Day and Next Day shipping are available at additional cost.

If You Need Service...

From Europe call our European Headquarters and Manufacturing Facility in Kolo, Poland at **+48-63-2626000** or **+48-3912-1319**. From the continental U.S., call us toll-free at **1-800-525-8100**. Ask to speak with a Customer Service Representative. Please have your vehicle identification number and your customer number ready when you call. The Service Representative can help you with questions about alignment of your mill, blade sharpening, or cutting a particular species of wood. He also can schedule you for a service call.

Office Hours: All times are Eastern Standard Time. Please remember that Indiana does not go on Daylight Savings Time in the summer.

Country	Monday - Friday	Saturday	Sunday
U.S., Indiana	8 a.m. to 5 p.m.	8 a.m. to 4 p.m.	Closed
Poland	8 a.m. to 4:30 p.m.	8 a.m. to 1 p.m.	Closed



IMPORTANT! Read the entire Operator's Manual before operating the sawmill. Take notice of all safety warnings throughout this manual and those posted on the machine. Keep this manual with this machine at all times, regardless of ownership.

*Wood-Mizer® is a registered trademark of Wood-Mizer Products, Inc.

Sawmill and Customer Identification

Each Wood-Mizer LT15 sawmill is identified with a revision and VIN numbers.

The VIN number contains the month, year and place of manufacture, the base model and the engine/motor configuration. The revision number helps identify the exact design of the equipment. See the figure for a description of the revision number.

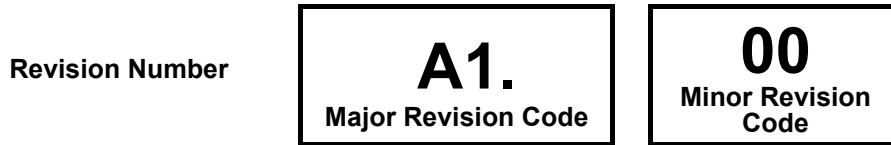

REVISION NUMBER DESCRIPTION.

When you pick up your mill, you will receive a customer number. The VIN number, revision, and your customer number expedite our service to you. Please write these numbers below so you have quick, easy access to them.

Customer No.	VIN No.	Revision No.

SECTION 1	SAFETY & GENERAL INFORMATION	1-1
1.1	Blade Handling.....	1-2
1.2	Sawmill Setup.....	1-2
1.3	Sawmill Operation.....	1-3
1.4	Sawmill Maintenance.....	1-5
1.5	Belt Sizes.....	1-7
1.6	Blade Sizes.....	1-7
1.7	Cutting Capacity.....	1-8
1.8	Engine/Motor Specifications.....	1-8
1.9	Overall Dimensions.....	1-9
1.10	Components.....	1-10
1.11	Electrical Information.....	1-11
SECTION 2	SAWMILL ASSEMBLY	2-1
2.1	Mounting Parts of LT15 Sawmills with Electric Motors.....	2-1
2.2	Unpacking the Sawmill.....	2-7
2.3	Bed Frame Assembly.....	2-9
2.4	Frame Leg Adjustment.....	2-14
2.5	Saw Head Assembly.....	2-15
2.6	Feed Rope Assembly.....	2-20
2.7	Auxiliary Bed Rail.....	2-24
SECTION 3	SETUP & OPERATION	3-1
3.1	Sawmill Setup.....	3-1
3.2	Replacing The Blade.....	3-10
3.3	Tensioning The Blade.....	3-11
3.4	Tracking The Blade.....	3-12
3.5	Starting The Motor.....	3-14
3.6	Loading, Turning, And Clamping Logs.....	3-15
3.7	Up/Down Operation.....	3-19
3.8	Blade Guide Arm Operation.....	3-20
3.9	Blade Drive Operation.....	3-21
3.10	Feed Operation.....	3-23
3.11	Cutting The Log.....	3-24
3.12	Edging.....	3-26
3.13	Blade Height Scale.....	3-27
3.14	Water Lube Operation.....	3-29
3.15	Transporting the Sawmill.....	3-32
SECTION 4	MAINTENANCE	6-1
4.1	Wear Life.....	6-1
4.2	Sawdust Removal.....	6-1
4.3	Carriage Track & Rollers.....	6-2
4.4	Vertical Mast Rails.....	6-2
4.5	Miscellaneous Lubrication.....	6-3
4.6	Blade Wheel Belts.....	6-4
4.7	Up/Down System.....	6-5
4.8	Miscellaneous Maintenance.....	6-8

SECTION 5 TROUBLESHOOTING GUIDE

7-1

5.1 Sawing Problems 7-1

SECTION 6 ALIGNMENT

8-1

6.1 Pre-Alignment Procedures..... 8-1
6.2 Preparing The Sawmill For Alignment 8-2
6.3 Blade Installation and Alignment..... 8-3
6.4 Blade Wheel Alignment 8-5
6.5 Blade Guide Arm Alignment..... 8-10
6.6 Aligning The Blade Guides 8-12
6.7 Blade Deflection 8-13
6.8 Blade Guide Vertical Tilt Adjustment..... 8-14
6.9 Blade Guide Spacing 8-16
6.10 Horizontal Tilt Adjustment..... 8-17
6.11 Side Supports..... 8-18
6.12 Blade Height Scale Adjustment..... 8-19
6.13 Motor Drive Belt Adjustment..... 8-20

SECTION 1 SAFETY & GENERAL INFORMATION



This symbol calls your attention to instructions concerning your personal safety. Be sure to observe and follow these instructions. This symbol accompanies a signal word. The word **DANGER** indicates an imminently hazardous situation which, if not avoided, will result in death or serious injury. **WARNING** suggests a potentially hazardous situation which, if not avoided, could result in death or serious injury. **CAUTION** refers to potentially hazardous situations which, if not avoided, may result in minor or moderate injury to persons or equipment. Read all safety instructions before operating this equipment and observe all safety warnings!



Warning stripes are placed on areas where a single decal would be insufficient. To avoid serious injury, keep out of the path of any equipment marked with warning stripes.

Read and observe all safety instructions before operating this equipment! Also read any additional manufacturer's manuals and observe any applicable safety instructions including dangers, warnings, and cautions.

Always be sure that all safety decals are clean and readable. Replace all damaged safety decals to prevent personal injury or damage to the equipment. Contact your local distributor, or call your Customer Service Representative to order more decals.

IMPORTANT! It is always the owner's responsibility to comply with all applicable federal, state and local laws, rules and regulations regarding the ownership and operation of your Wood-Mizer sawmill. All Wood-Mizer mill owners are encouraged to become thoroughly familiar with these applicable laws and comply with them fully while using the mill.

Always properly dispose of all sawing by-products, including sawdust and other debris, coolant, oil, oil filters and fuel filters.

Safety instructions are listed in this section by the following operations:

- Blade Handling
- Sawmill Setup
- Sawmill Operation
- Sawmill Maintenance

1.1 Blade Handling



DANGER! Always disengage the blade and shut off the sawmill engine before changing the blade. Failure to do so will result in serious injury.



WARNING! Always wear gloves and eye protection when handling bandsaw blades. Changing blades is safest when done by one person! Keep all other persons away from area when coiling, carrying or changing a blade. Failure to do so may result in serious injury.

1.2 Sawmill Setup



WARNING! Do not set up the mill on ground with more than a 10 degree incline. If setup on an incline is necessary, put blocks under one side of the mill or dig out areas for the legs to keep mill level. Setting up the mill on an incline could cause it to tip over, resulting in serious personal injury.

WARNING! Keep all persons out of the path of the saw head while loading and unloading the sawmill. Failure to do so may result in serious injury or death.

1.3 Sawmill Operation



DANGER! Make sure all guards and covers are in place and secured before operating or towing the sawmill. Failure to do so may result in serious injury.

DANGER! Be sure the blade housing and pulley covers are in place and secured.

DANGER! Always keep hands away from moving bandsaw blade. Failure to do so will result in serious injury.

DANGER! Keep all persons out of the path of moving equipment and logs when operating sawmill or loading and turning logs. Failure to do so will result in serious injury.

DANGER! Maintain a clean and clear path for all necessary movement around the mill and lumber stacking areas. Failure to do so will result in serious injury.

DANGER! Always be sure the blade is disengaged and all persons are out of the path of the blade before starting the engine or motor. Failure to do so will result in serious injury.

WARNING! Always wear eye, ear, respiration, and foot protection when operating the sawmill. Failure to do so may result in serious injury.



WARNING! Secure all loose clothing and jewelry before operating the sawmill. Failure to do so may result in serious injury or death.

WARNING! Always make sure log is clamped securely before sawing. Failure to do so may result in serious injury or death.

WARNING! Use ONLY water or alcohol solution with the water lube accessory. Never use flammable fuels or liquids. If these types of liquids are necessary to clean the blade, remove it and clean with a rag. Failure to do so may result in serious injury or death.



CAUTION! Be sure the log clamps are all the way down before loading a log onto the bed. Failure to do so may result in machine damage.

CAUTION! Before loading a log, be sure the cutting head is moved far enough forward so the log does not hit it. Failure

to do so may result in machine damage.

CAUTION! Do not try to force the saw head beyond its upper and lower travel limits. Damage to the up/down system may result.

CAUTION! Be sure to stop the blade when returning the carriage. This will not only prevent the blade from being pulled off and ruined by a wood sliver, but also will increase the life of the blade.

CAUTION! The saw head will hit the spring-loaded ramp stops when adjusted for low cuts. Remove the loading ramps before sawing to prevent damage to the saw head and/or blade guide arm.

1.4 Sawmill Maintenance



CAUTION! The up/down screw bellows should completely cover the screw. If either of the bellows is damaged, replace it immediately. Before installing the new bellows, clean the up/down screw and nut thoroughly with extraction naphtha and then grease them.

CAUTION! Reinstall the track wiper so that it lightly touches the track bar. If the wiper presses too firmly against the bar, it can cause the power feed to bind.

CAUTION! Never use grease on the mast rails as it will collect sawdust.

Pictogram decals used to warn the user about danger in the LT15:

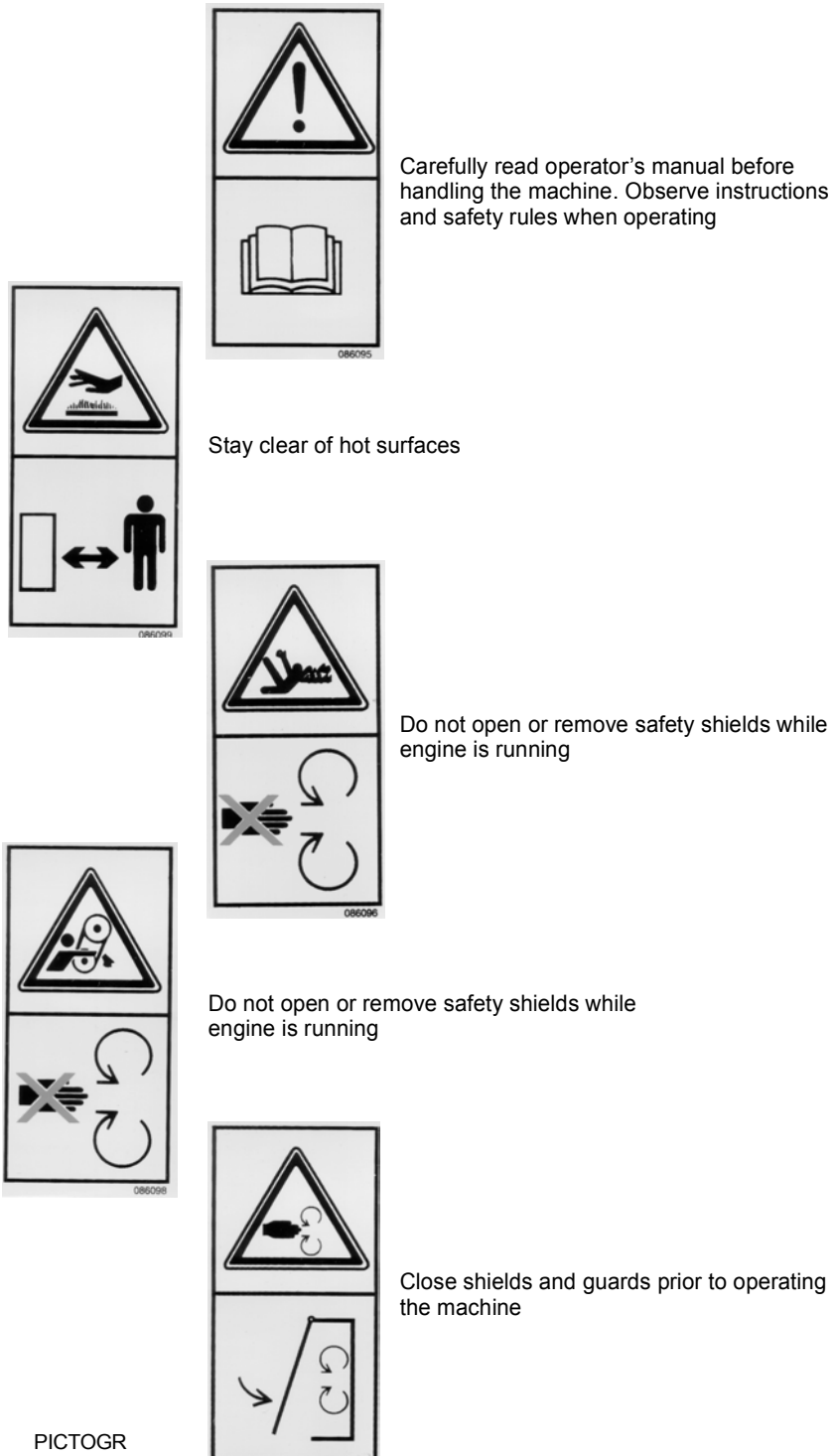

FIG. 1-0

1.5 Belt Sizes

See Table 1-1. Belt sizes for the LT15 are shown.

Description	Belt Size	Wood-Mizer Part #
Motor Drive Belt (E11)	B81	014819
Up/Down Drive Belt	AVX13x1030	094253
Blade Pulley Belts	B57 ¹	P04185

TABLE 1-1

¹ To insure proper blade tracking, use Goodyear, Dayco Super II, or Browning belts only.

1.6 Blade Sizes

See Table 1-2. Wood-Mizer TRU•SHARP™ offers three types of blades to provide efficient sawing for all models of sawmills. The engine/motor size of your sawmill and the type of wood you saw should determine which blade you choose for optimum performance.

Engine/Motor Size	Recommended Blade For Sawing:		
	Softwood	Hardwood	Frozen or Hard-to-Cut Wood
5 hp - 15hp	B275IH1030 B275IH741030	B375IH929	B375IH929 ¹
16hp or more	B376IH1030 B376IH741030	B275IH1030 B275IH741030 B376IH1030 B376IH741030 ²	B375IH929 ¹
Electric Motor	B376IH1030 B376IH741030	B275IH1030 B275IH741030 B376IH1030 B376IH741030 ²	B375IH929 ¹

TABLE 1-2

¹ TRU•SHARP™ “F” blades use a 9/29 profile (9° hook angle and 29° back angle) and are designed to cut frozen and/or extremely dense, hard-to-cut wood. Standard TRU•SHARP™ blades use a 10/30 profile.

² Customer may choose preferred blade.

See *The Blade Handbook* for blade hook angle, tooth height, and tooth set specifications.

1.7 Cutting Capacity

See Table 1-3. The log size capacities of the LT15 sawmills are listed below.

	Max. Diameter	Max. Length ¹
LT15 S3	71 cm	5,4 m
LT15 S2	71 cm	3,5 m
LT15 M2	71 cm	5,2 m
LT15 M3	71 cm	7,9 m

TABLE 1-3

¹ Each additional bed frame segment adds approximately 195 cm (6' 5") to length capacity.

See Table 1-4. The performance capacity of the LT15 sawmill is listed below. Peak cutting rates are measured in 12" (30 cm) wide red oak and represent the capability of the sawmill only. Rates based on using Tru-Sharp 1 1/4" x .042 blades.

Model	Cutting Rate
LT15 E11, G13, D10	16 ft. (3.3 m)/min.

TABLE 1-4

1.8 Engine/Motor Specifications

See Table 1-5. The power options available for the LT15 sawmill are listed below.

Engine/Motor Type	Manufacturer	Model No.	Specification
7.5 kW Motor	Siemens, Germany	1LA7131-2AA60	3 x 400V, 50 Hz
11 kW Motor	Indukta, Poland	Sg132S-2PC	3 x 400V, 50 Hz
13hp Gasoline	Kohler	CH13T Spec #PA22519	398 cc
10hp Engine	Yanmar, Japan	L100	406 cc, 3600 min ⁻¹
Up/Down Motor 0.55kW	Besel	SKh71X-4C2/HPS08	3x 230/400VAC, 50Hz

TABLE 1-5

1.9 Overall Dimensions

See Figure 1-1. The overall dimensions of the LT15 sawmills are shown below.

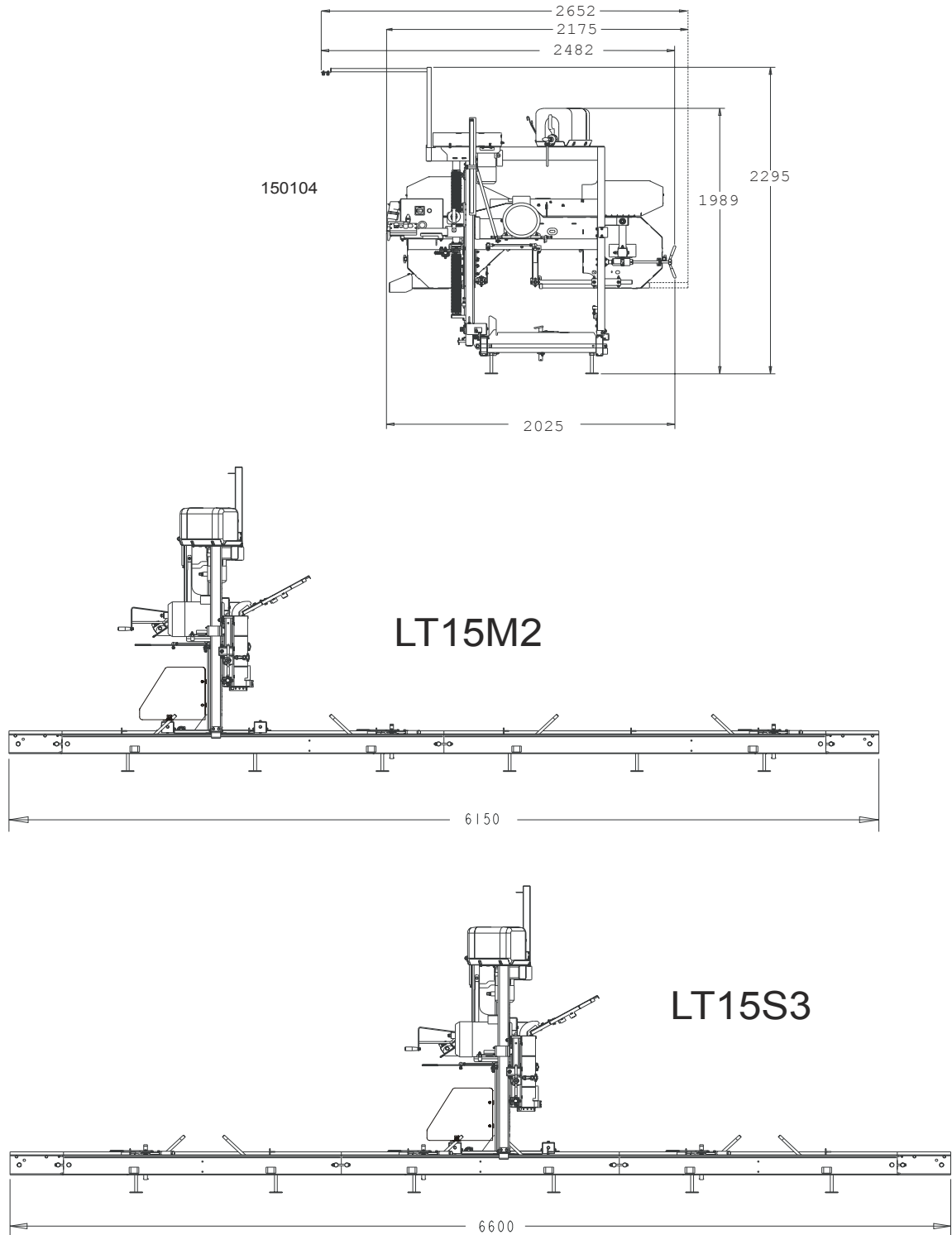

FIG. 1-1

1.10 Components

See Figure 1-2. The major components of the Wood-Mizer LT15 are shown below.

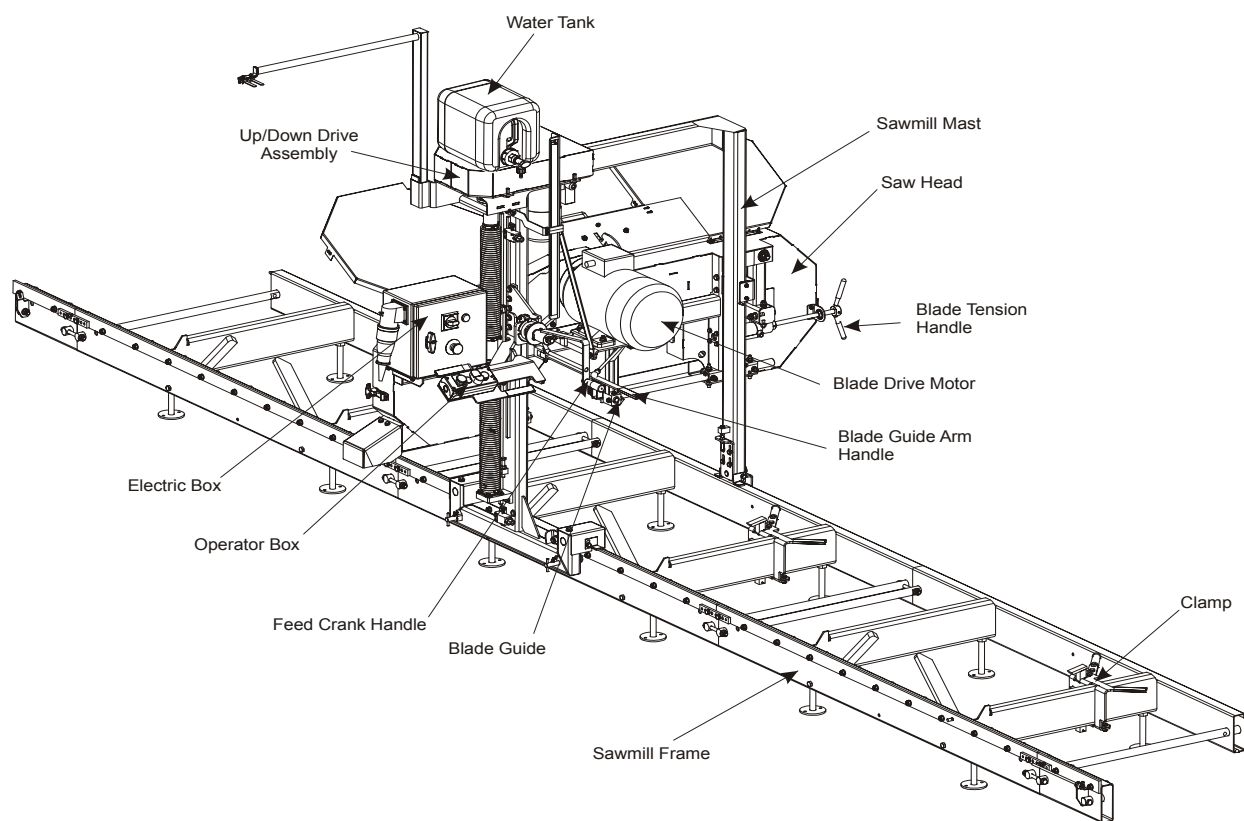

FIG. 1-2

1.11 Electrical Information

See Figure 1-3. The electrical symbol diagram of the LT15 equipped with the E11 electric motor is shown below.

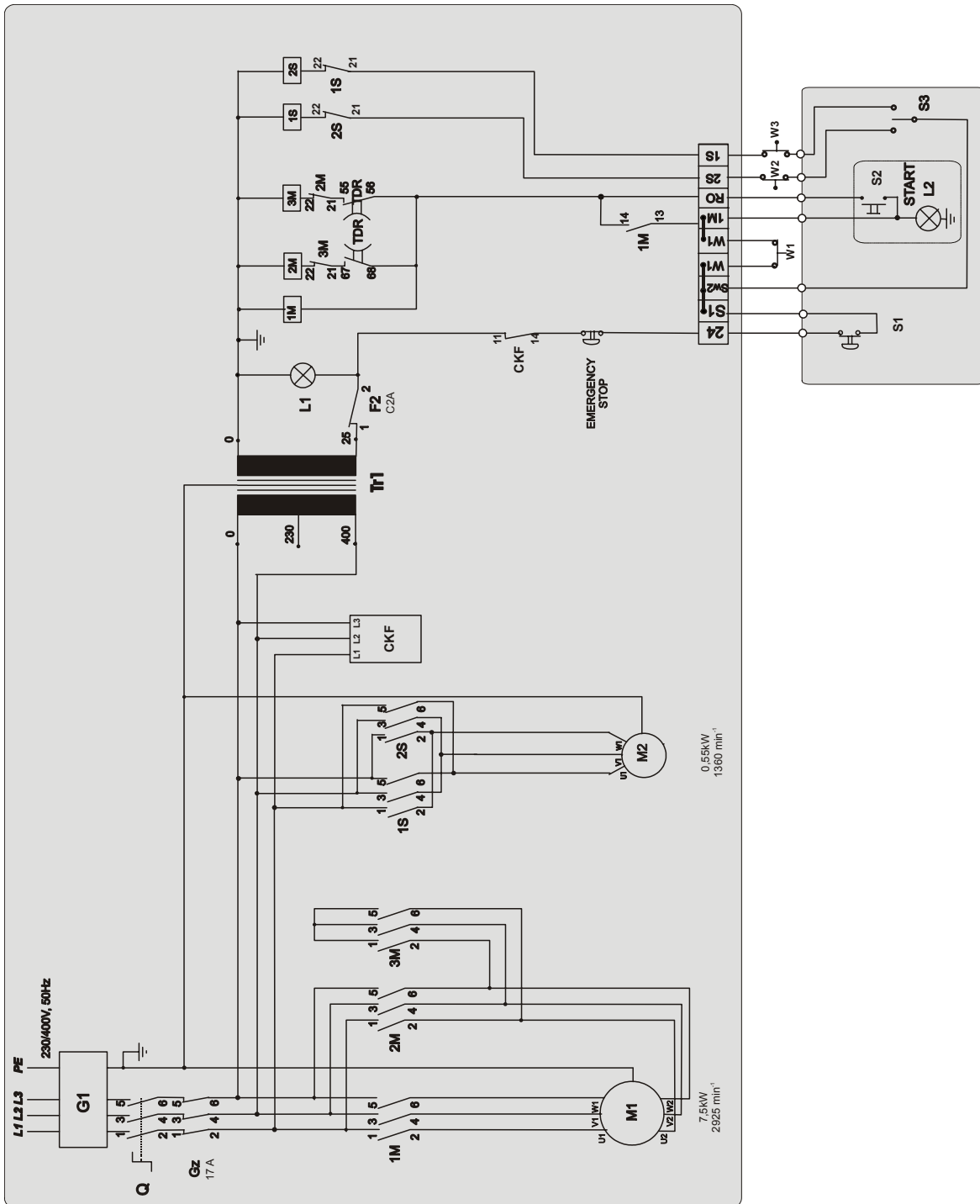

FIG. 1-3

See Figure 1-4. The electrical components are listed in the table below.

Symbol	Mfg. Part No.	Manufacturer	Wood-Mizer Part #	Description
GZ	GZ1 M20	SCHNEIDER	090561	Switch, Motor On/Off
F2	C60N C2 24396	SCHNEIDER	088278	Switch
Q	ABB OT16E3	ABB	089801	Disconnecter
TR	TMM 63/A	BREVE	094487	Transformer
1M, 2M, 3M	LC1 D09 B7	SCHNEIDER	094805	Contacto
1S, 2S	LC1 K0601	SCHNEIDER	084309	Contacto
TDR	LAD S2	SCHNEIDER	084037	Relay, Time
L1	M22	MOELLER	090448	Control Light M22 White-LED 24V
S1	M22-DP-R	MOELLER	094328	Safety Button
S2/L2	M22-XDL-G	MOELLER	094315	START Button
S3	M22-DDL-S-X7/X7	MOELLER	090917	Up/Down Drive Button
M1	1LA7131-2AA60	SIEMENS	085482	Blade Drive Motor
M2	Skh71X 4C2	BESEL	091186	Up/Down Drive Motor
W1	AZ17-11ZRK	SCHMERSAL	094232	Safety Switch
W2,W3	EVN2000C	HONEYWELL	089816	Limit Switch
CKF	RM4 TG20	SCHNEIDER ELECTRIC	084452	Phase Supply Control Relay

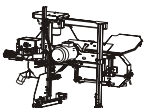
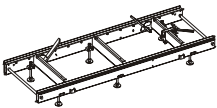
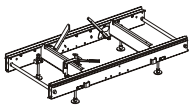
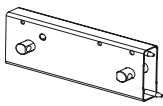

TABLE 1-6

SECTION 2 SAWMILL ASSEMBLY



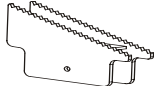
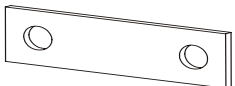
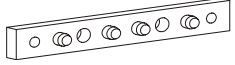

2.1 Mounting Parts of LT15 Sawmills with Electric Motors

2.1.1 Parts specifications

Tabel 1:

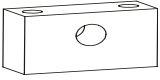
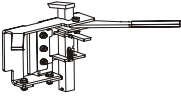
Fig.	Wood-Mizer Part No.	Description	Qty. LT15S3	Qty. LT15M2
	094132	LT15 Sawmill Saw Head	1	1
	094697	LT15 Bed Section, Complete (2.75 m)	--	2
	094514	LT15 Bed Section, Complete (1.95 m)	3	--
	094249-1	Bed Extension Tube, Painted	2	2
	092569-1	Feed Rope Mount Bracket	1	1
	094250-1	Track Rail, Zinc-plated (Short)	2	2
	086035-1	Leveling Wedge, Painted	1	1
	085994-1	Bed Leg Mounting Washer, Painted	12	12
	086659-1	Frame Mounting Strap, Zinc-plated	4	3

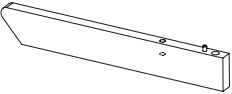
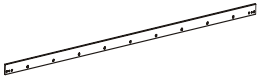
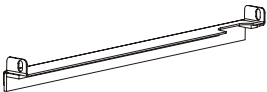
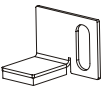

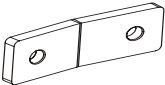
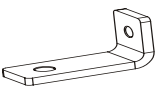



Tabel 1:

	095745-1	Leg Mounting Block	12	12
	094530	Log Clamp	3	2
	092570-1	Feed Rope Mount Bracket	1	1
	085982-1	Log Side Support, Complete	6	4
	094427-1 (LT15S3) 094696-1 (LT15M2)	Track Rail	3	2
	R02080	Rope	9	8,7
	086745	Middle Track Cover with Felt Wiper	1	1
	086323	Left Track Wiper	2	2
	086322	Right Track Wiper	2	2
	093859	Plate, PC Guard	1	1
	086171-1	Side Bracket	2	2
	086172-1	Bottom Bracket	1	1

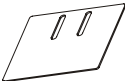
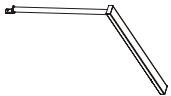

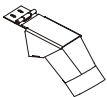
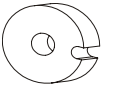

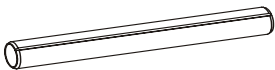

2 SAWMILL ASSEMBLY

Parts specifications

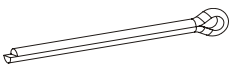
Tabel 1:

	092378-1	Bracket, Blade Guide Roller Guard	1	1
	092379-1	Blade Guide Roller Guard	1	1
	086132-1	Power Cord Bracket	1	1
	095490-1	Auxiliary Bed Rail	1	1
	092460-1	Sawdust Chute	1	1
	085981-1	Thick Spacer Washer	6	4
	086723-1	LT15 Foot Mount Plate	12	12
Vertical Mast Lock Assembly				
	086743-1	Zinc-plated Pin	2	2
	F81045-1	Roll Pin 6x50	2	2
	F81044-21	Roll Pin 3x20	2	2
	087301	Compression Spring 18x37x1.8	2	2

Tabel 1:

	F81043-2	Cotter Pin S-Zn 4x25	2	2
	F81058-1	Flat Washer 17	2	2
Power Feed Assembly				
	094191-1	Power Feed Crank Handle	1	1
	094142	Bushing	2	2
	086338	Crank Handle Grip	1	1
	F81033-1	Hex Nylon Lock Nut M10	1	1

2.1.2 Specifications of Fasteners

Tabel 2:

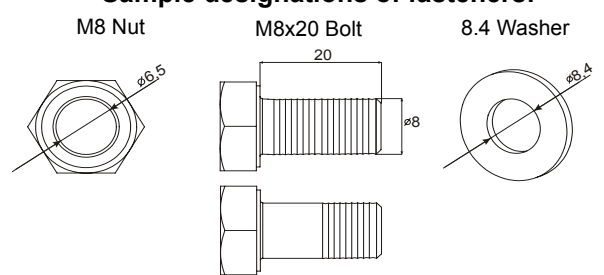
Wood-Mizer No.	Description	Qty. LT15S3	Qty. LT15M2
Sample designations of fasteners:			
			
F81056-1	13 Flat Washer	36	26
F81004-12	M12x55 Bolt	2	2
F81031-2	M6-8-B Nut	2	2

Tabel 2:

F81030-2	M5 Nut	2	2
F81000-7	M5x25 Bolt	2	2
F81053-11	6.5 Special Flat Washer	6	6
F81001-15	M6x16-8.8 Bolt	2	2
F81001-7	M6x12 Bolt	2	2
F81054-1	8.4 Flat Washer	16	16
F81032-2	M8 Nut	3	3
F81002-5	M8x25 Bolt	3	3
F81002-4	M8x20 Bolt	10	10
F81055-2	10.2 Split Lock Washer	8	8
014972	33/64 x1" x 1/32 Nylon Washer	6	4
F81003-11	M10x25 Bolt	8	6
F81003-1	M10x20 Bolt	8	6
F81059-2	21 Flat Washer	12	12
F81034-2	M12 Hex Nylon Lock Nut	20	16
F81033-1	M10 Hex Nylon Lock Nut	55	54
F81055-1	10.5 Flat Washer	94	92
F81004-36	M12x130 Bolt	6	4
F81004-38	M12x120 Bolt	12	8
F81037-1	M20 Nut	12	12
F81003-58	M10x120 Bolt	24	24
F81003-15	M10x75 Bolt	31	30
087771-1	Bed Leg Foot	12	12
095742-1	LT15 Foot	12	12
F81082-1	Band	2	2

2.1.3 Tools Necessary for Assembling the Sawmill**Tabel 3:**

Required Tools	
Flat Wrench #8	1pcs
Flat Wrench #10	2pcs
Flat Wrench #13	2pcs
Flat Wrench #17	2pcs
Flat Wrench #19	2pcs
Ratchet Wrench #30	1pcs
Hammer	1pcs
Allen Wrench #4	1pcs
Allen Wrench #5	1pcs

2.2 Unpacking the Sawmill



FIG. 2-1

1. Cut the bands holding the components together.
2. Remove the parts arranged inside the bed section.
3. Using a forklift truck or a winch with lifting capacity of minimum 500 kg, carefully lift the saw head and set it aside. Then attach the winch hook to the bracket on the saw head.



WARNING! When removing the saw head, use extreme care and keep all persons at a safe distance. Failure to do so may result in serious injury or death.

See Figure 2-2.

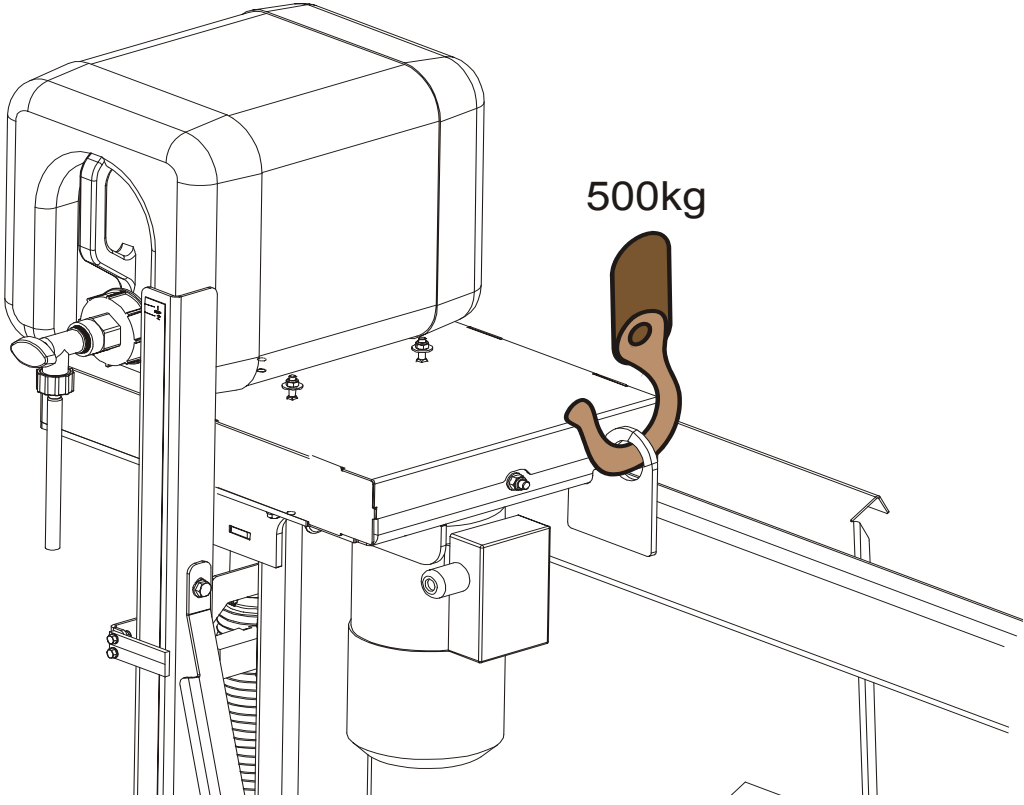

FIG. 2-2

2.3 Bed Frame Assembly



IMPORTANT! With all screw joints without split lock washer or lock nylon nut, use the "LOCTITE 243" (blue, of average durability, for screw joints).

1. Mount preliminarily the track rail as shown in Figure 2-3. Do not tighten the nuts.

See Figure 2-3.

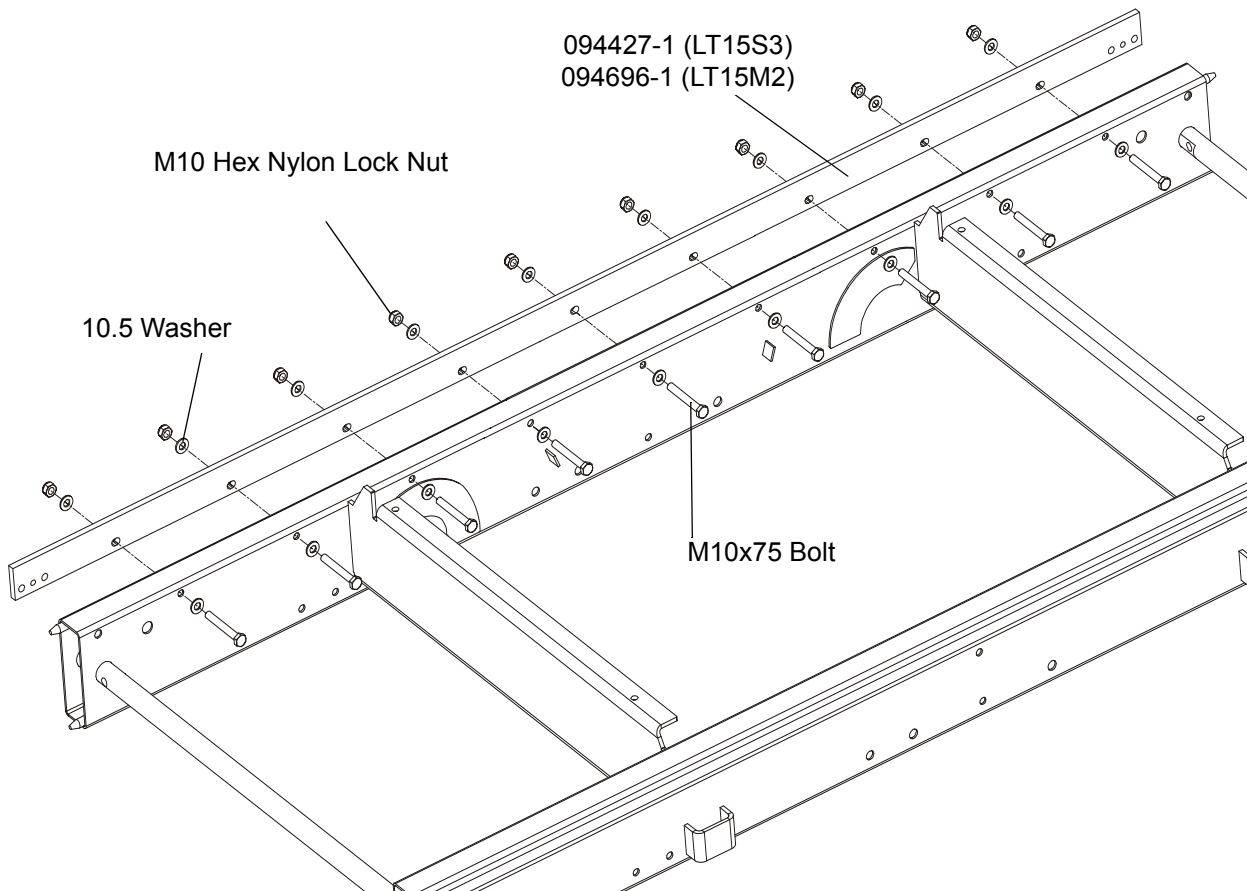

FIG. 2-3

2. Mount four leg brackets to each bed section. Use two hex head bolts and lock nuts to secure each leg bracket to the bed section. Be sure the nut on the bracket faces up. Thread a leg into each bracket.

See Figure 2-4.

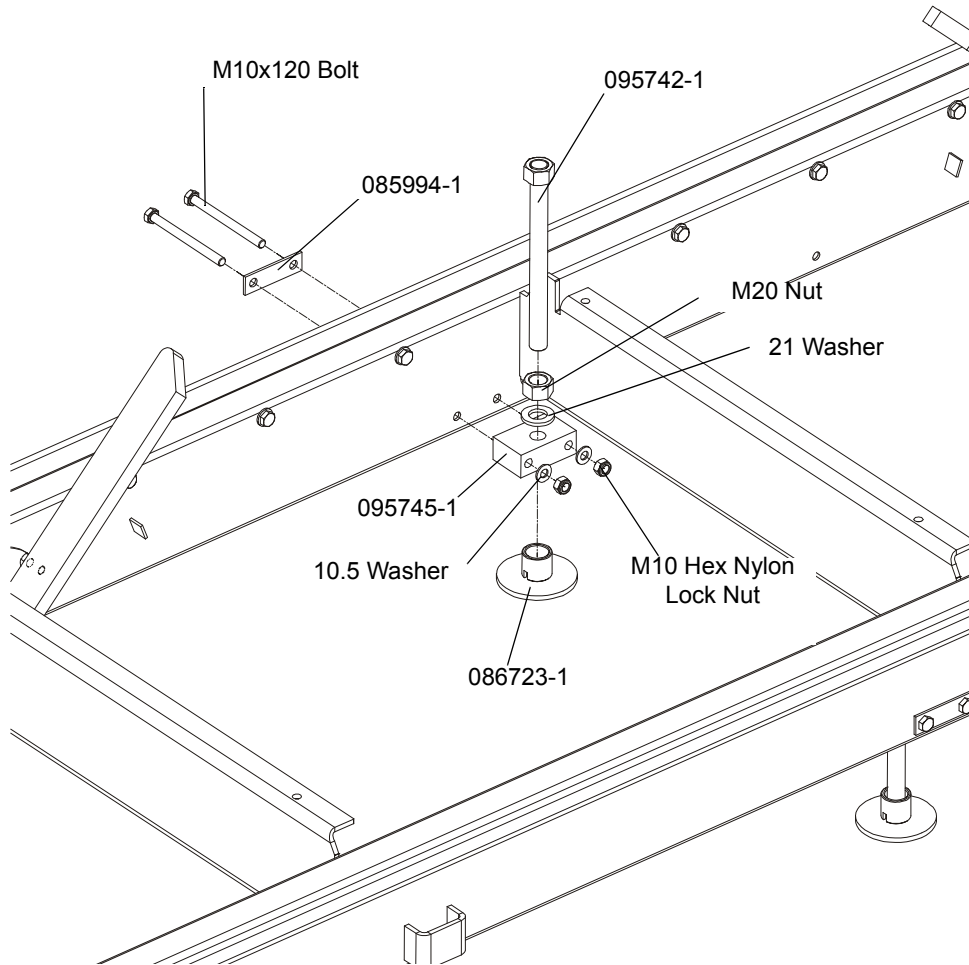

FIG. 2-4

2 SAWMILL ASSEMBLY

Bed Frame Assembly

3. Lay the frame sections end-to-end so the track portion of each section is on the same side. Slide the sections together and secure with four hex head bolts and nylon lock nuts.

See Figure 2-5.

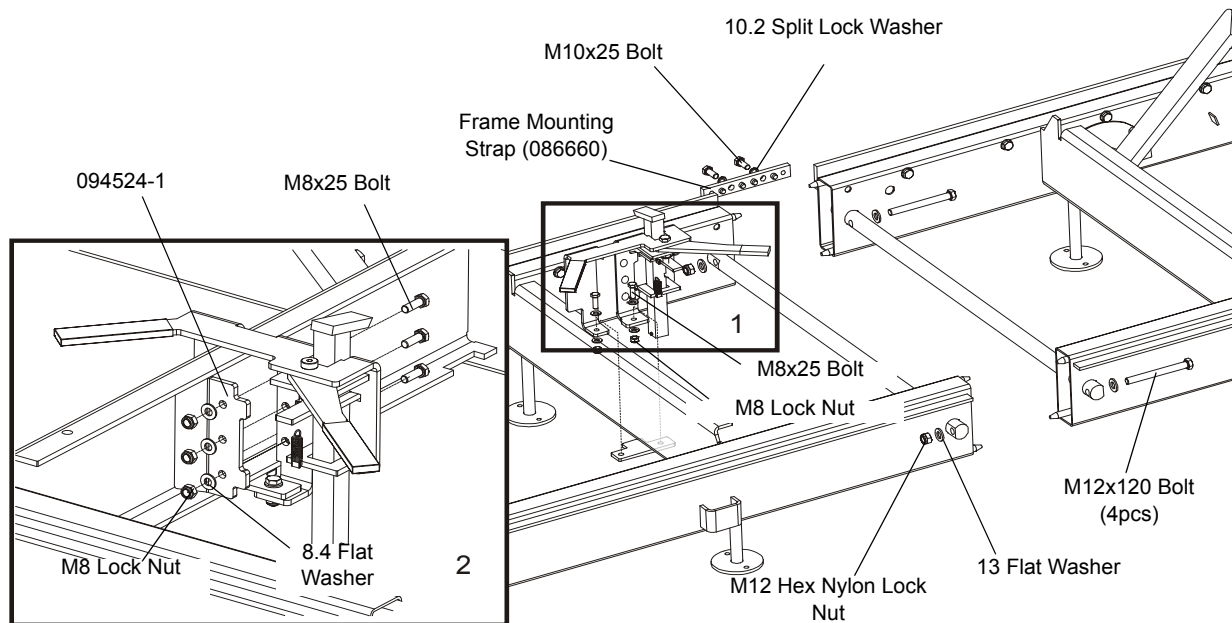

FIG. 2-5

4. Fasten the track rails together using the frame mounting straps, on the outside of the frame. (See the figure above.) Secure each strap to the track rail with two hex head bolts. Tighten the track rail mounting nuts.

5. Mount a bed extension to the front and the rear ends of the bed frame.

See Figure 2-6.

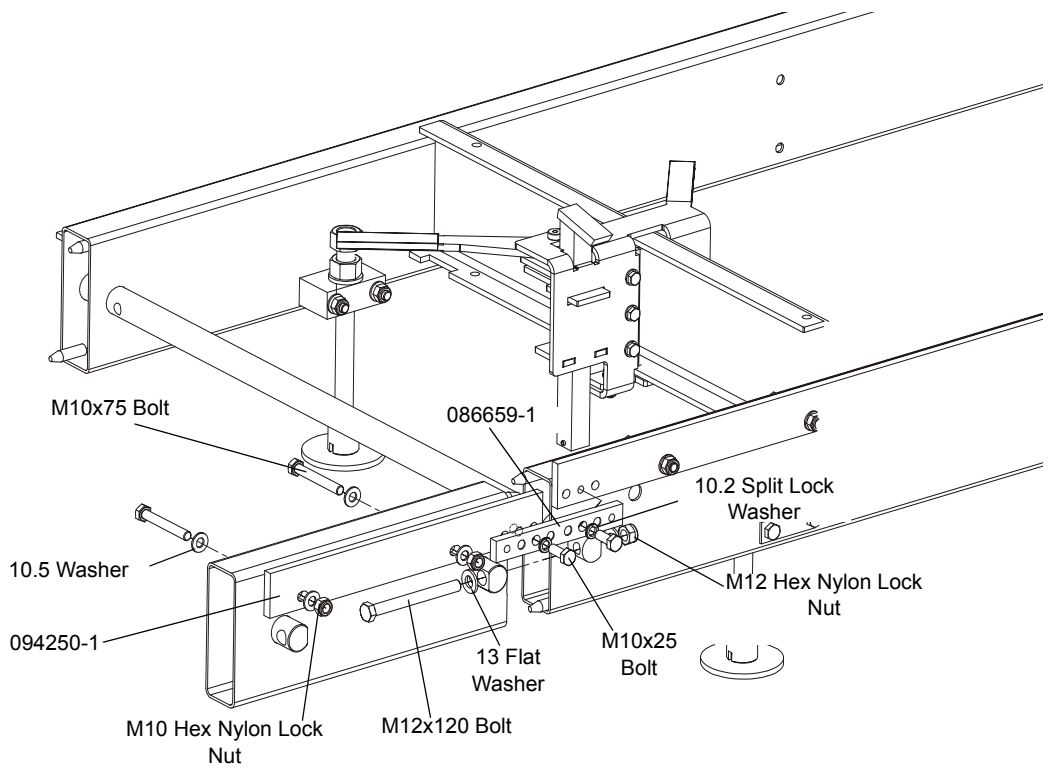

FIG. 2-6

6. Assemble a log clamp to a bed rail on each bed section using the existing hex head bolts and nylon lock nuts.

2 SAWMILL ASSEMBLY

Bed Frame Assembly

7. Install the log side supports as shown in Figure 2-7. Tighten the nuts so that the side supports can be moved with little resistance. Adjust the side supports. [See Section 6.11](#)

See Figure 2-7.

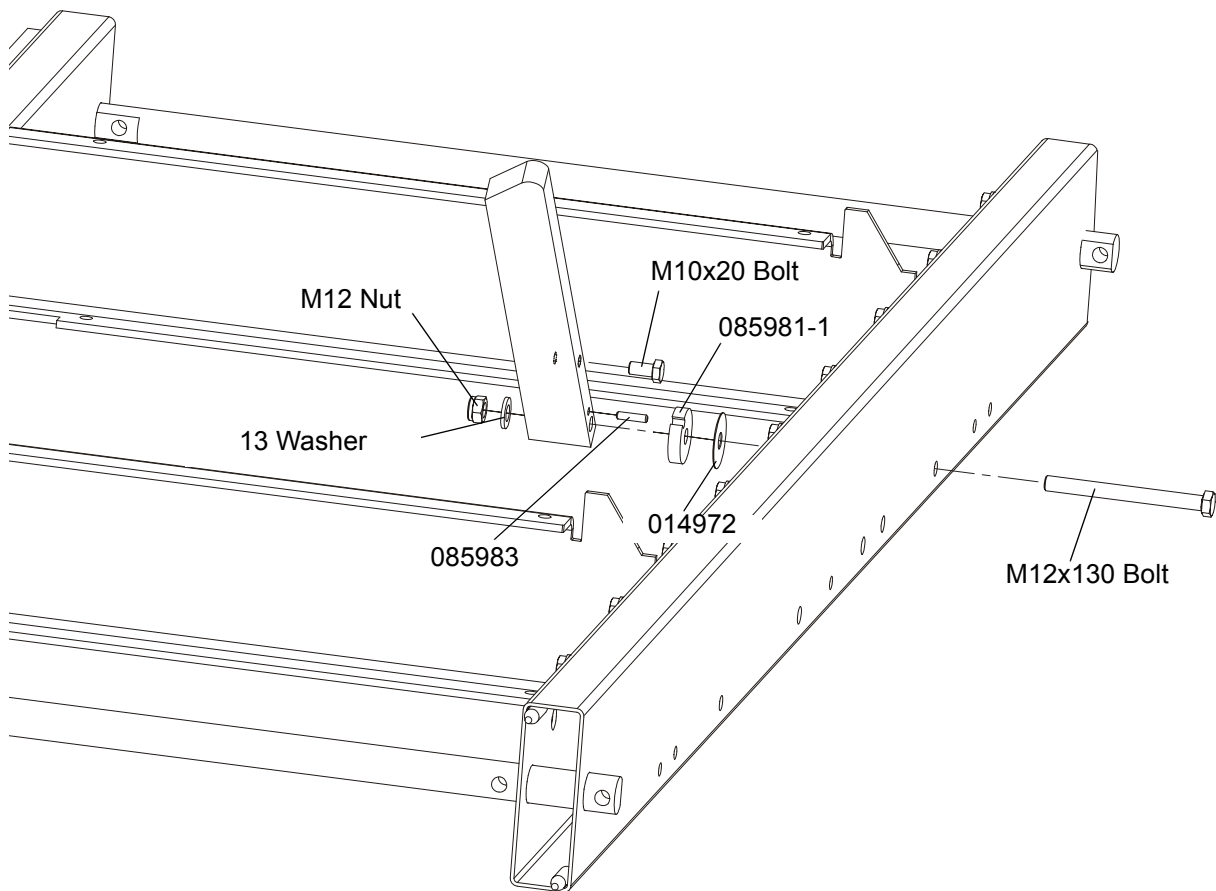

FIG. 2-7

2.4 Frame Leg Adjustment

1. Place a foot plate under each bed leg.
2. Using an appropriate wrench, adjust each leg so that the nut is approximately 25mm below the top of the bed tube

See Figure 2-8.

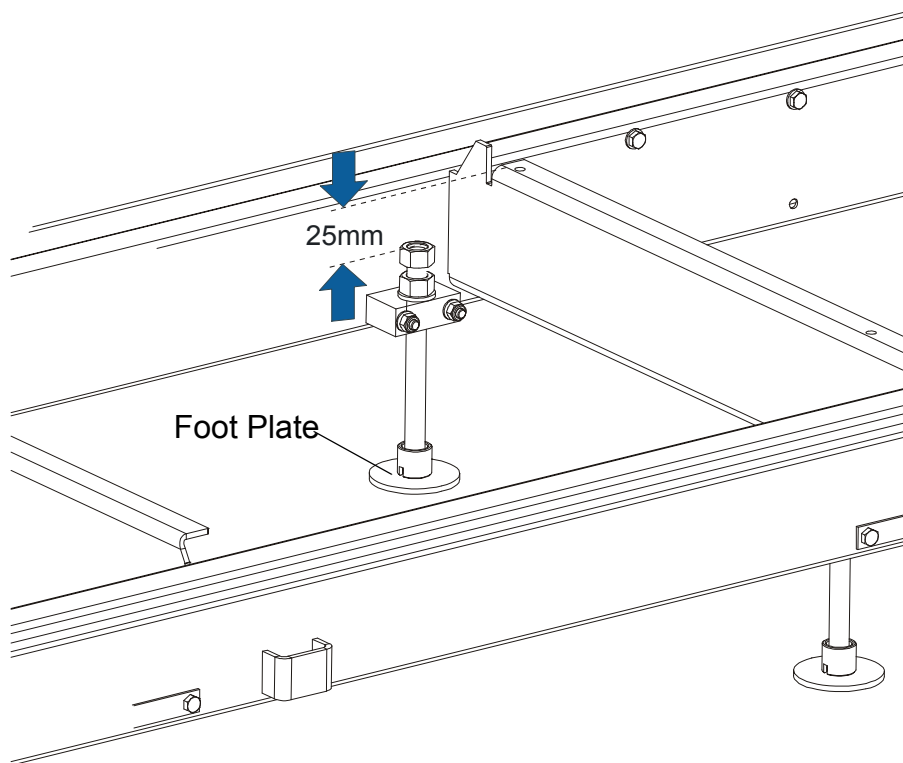

FIG. 2-8



CAUTION! The top of the leg should not be higher than the top surface of the bed rail.

2.5 Saw Head Assembly

1. Position the saw head at the end of the bed frame assembly. Carefully slide the saw head rollers onto the bed frame track. Keep the saw head square to the bed to avoid putting the track rollers in a bind.



WARNING! When setting the saw head on the bed frame, use extreme care and keep all persons at a safe distance. Failure to do so may result in serious injury or death.

2. Position the middle track cover between the two track roller housings so the opening in the cover is positioned over the feed rope pulleys. Secure with two hex head bolts and lock washers.
3. Install a track wiper with a felt strip to each track roller housing using a 8.4 flat washer and M8x12 hex head bolt.

See Figure 2-9.

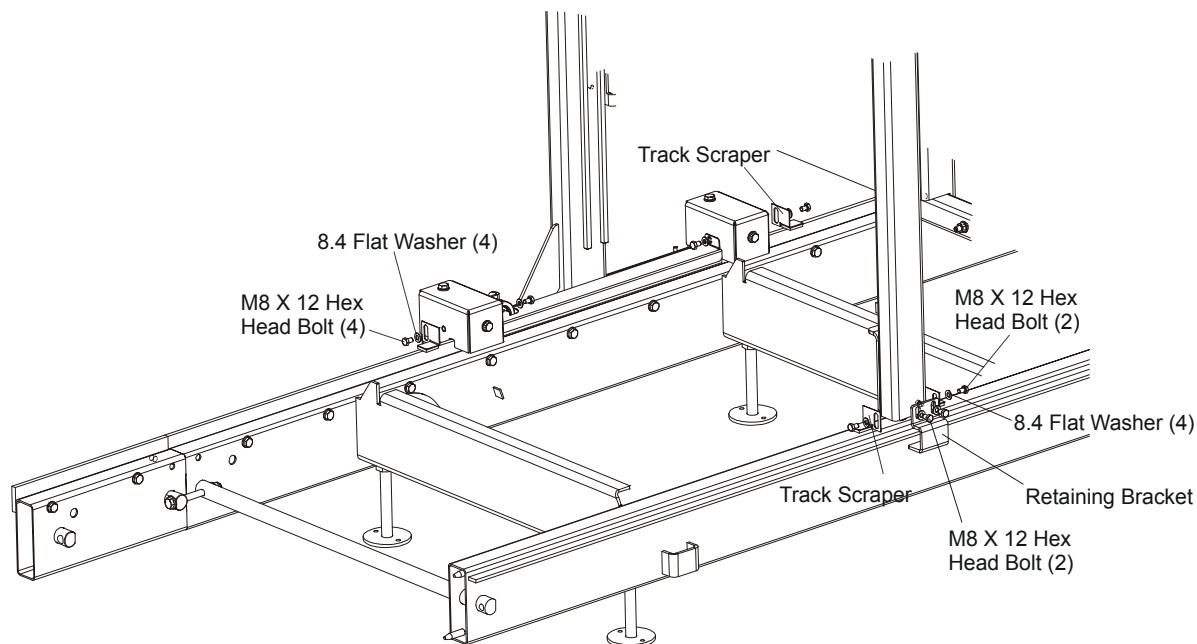

FIG. 2-9

4. Assemble the retaining bracket to the idle side upright with two hex head bolts and flat washers.
5. Assemble the two track wipers to the idle side upright using hex head bolt and flat

washers.

NOTE: Before installing the middle track cover and the remaining felt wipers, soak the felt strips with lubricating fluid (e.g. WD40).

- 6. Assemble mast safety pins.

See Figure 2-10.

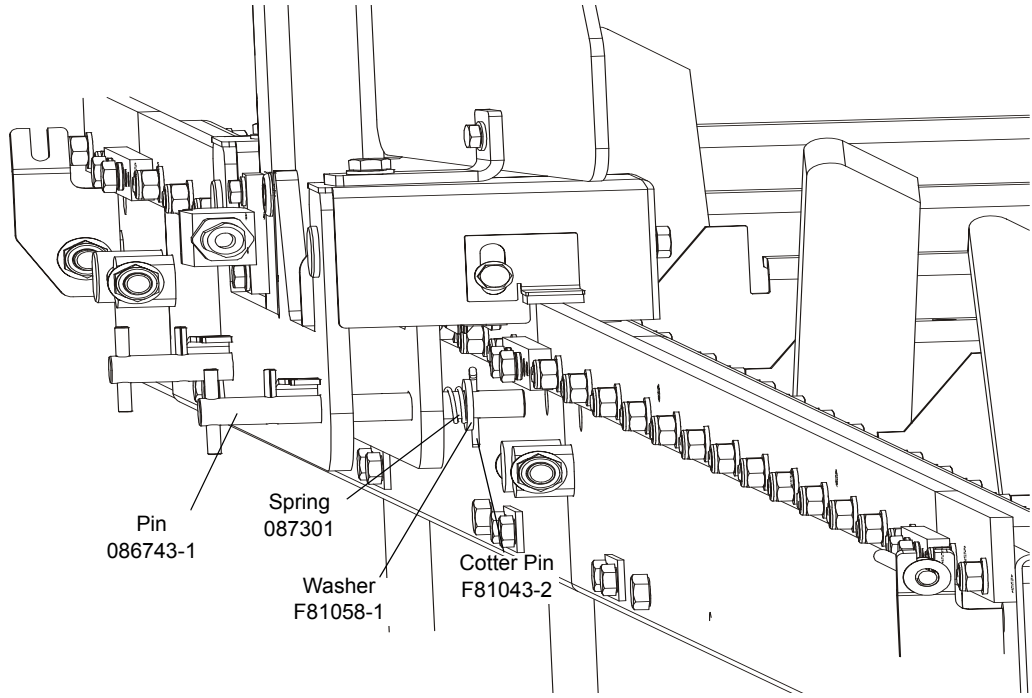

FIG. 2-10

2 SAWMILL ASSEMBLY

Saw Head Assembly

7. Install the PC operator guard.

See Figure 2-11.

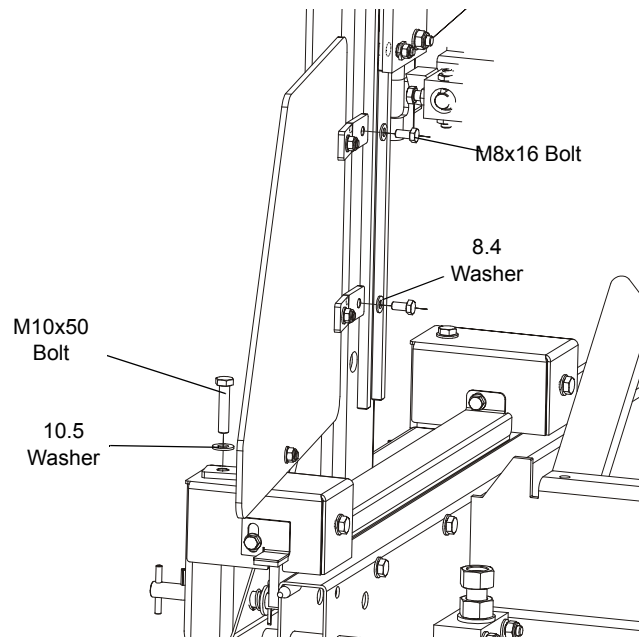

FIG. 2-11

8. Install the blade guides.

See Figure 2-12.

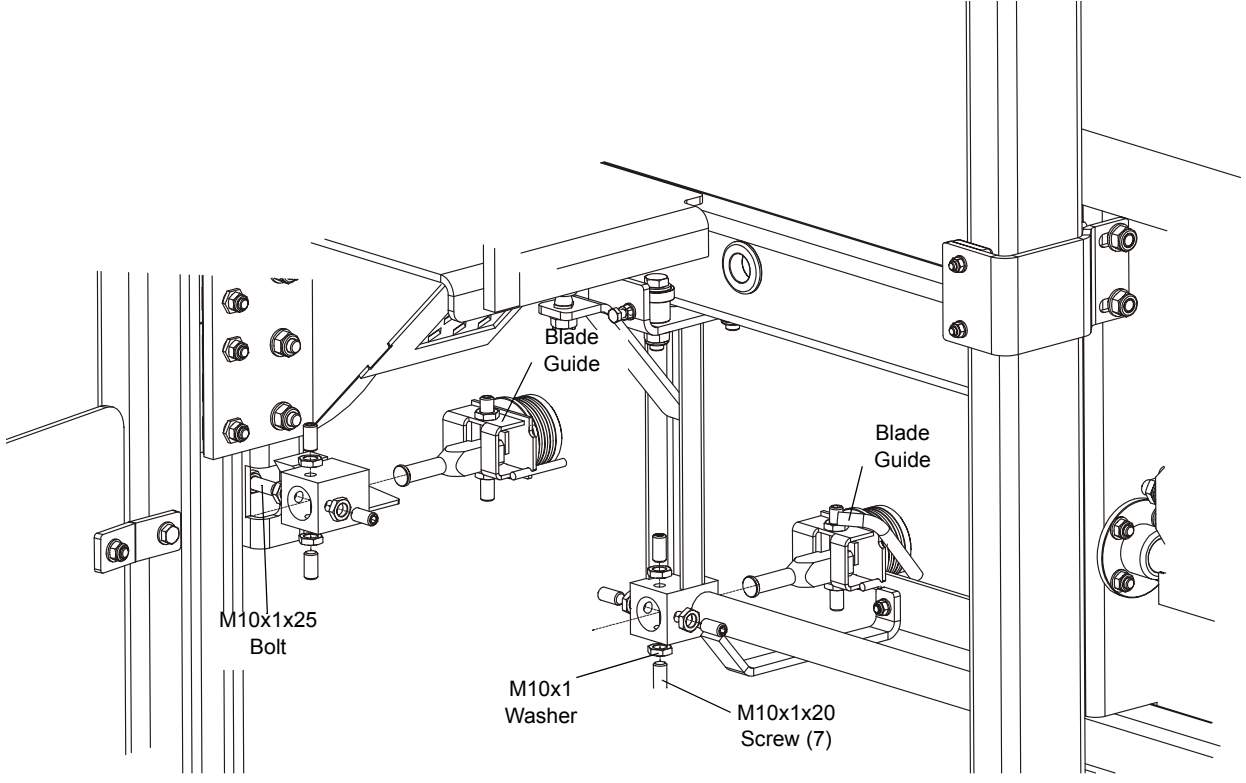

FIG. 2-12

2 SAWMILL ASSEMBLY

Saw Head Assembly

9. Install the power cord bracket.

See Figure 2-13.

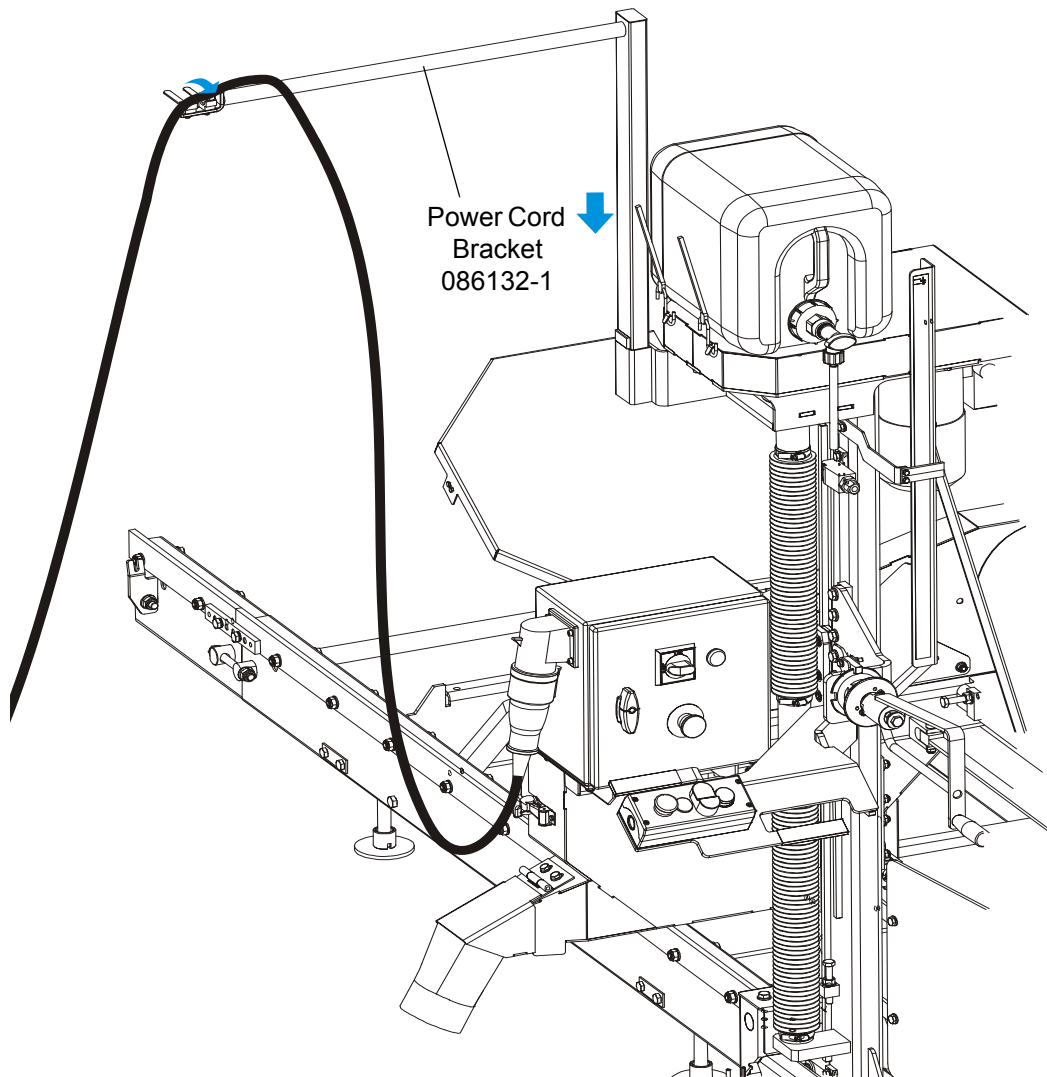

FIG. 2-13

10. Adjust the cam engaging the limit switch as well as the saw head stop bolt. [See Section 3.1, step 16.](#)

2.6 Feed Rope Assembly

1. Install a feed rope mounting bracket at each end of the bed assembly using a M12x55 hex head bolt and a nylon lock nut. Either bracket should be angled toward the end of the frame at which it is mounted as shown below.

See Figure 2-14.

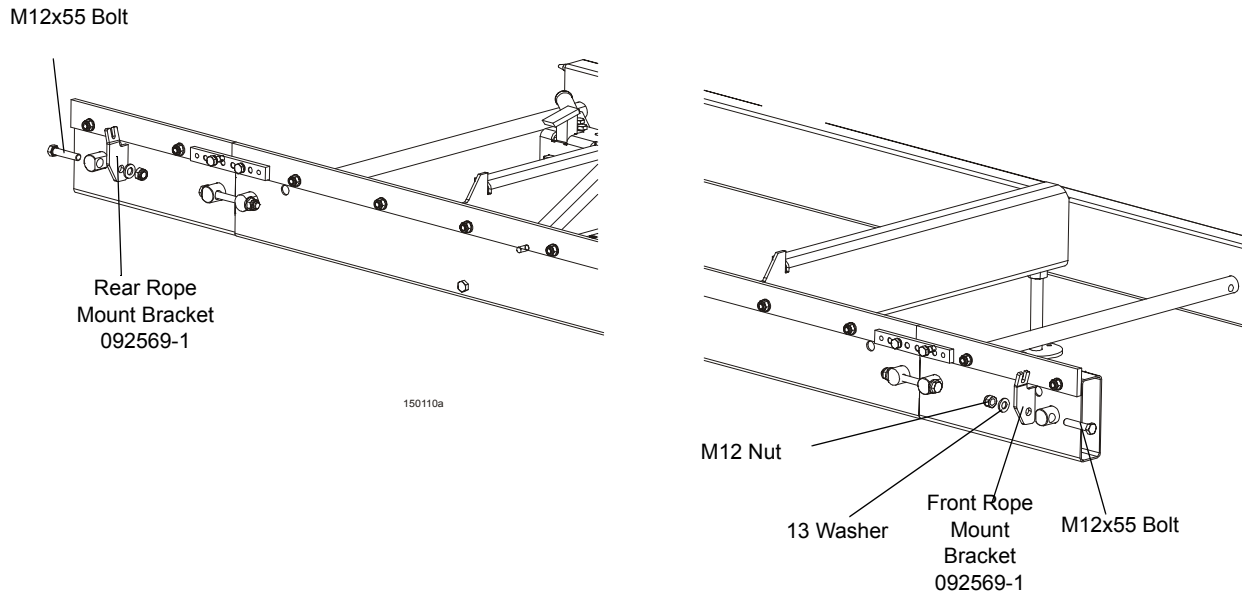

FIG. 2-14

2. Tie a knot in one end of the feed rope. Slip the knotted end of the rope into the front rope mount bracket. Route the rope between the saw head and main bed frame tube.

2 SAWMILL ASSEMBLY

Feed Rope Assembly

See Figure 2-15.

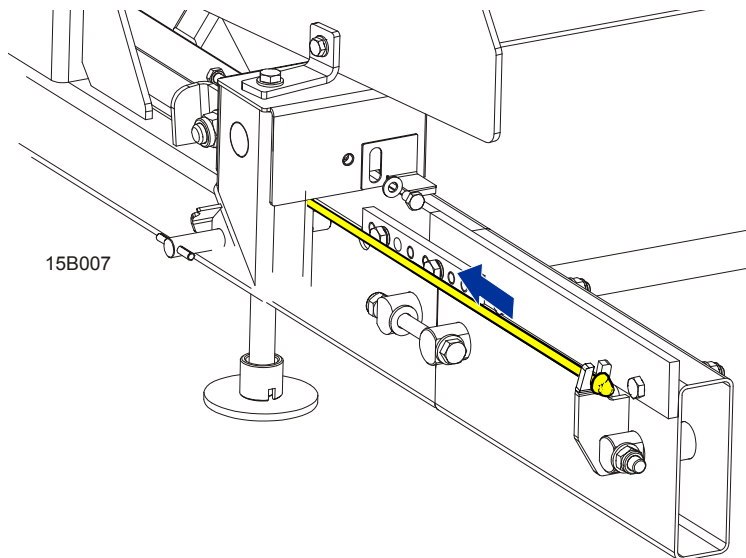

FIG. 2-15

3. Loop the rope around the inner groove of the lower v-groove roller and route to the feed crank spool.

See Figure 2-16.

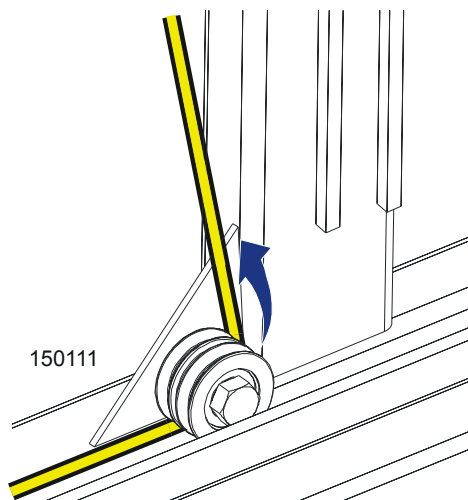

FIG. 2-16

4. Loop the rope around the feed crank spool three times and route back down to the outer v-groove roller.

See Figure 2-17.

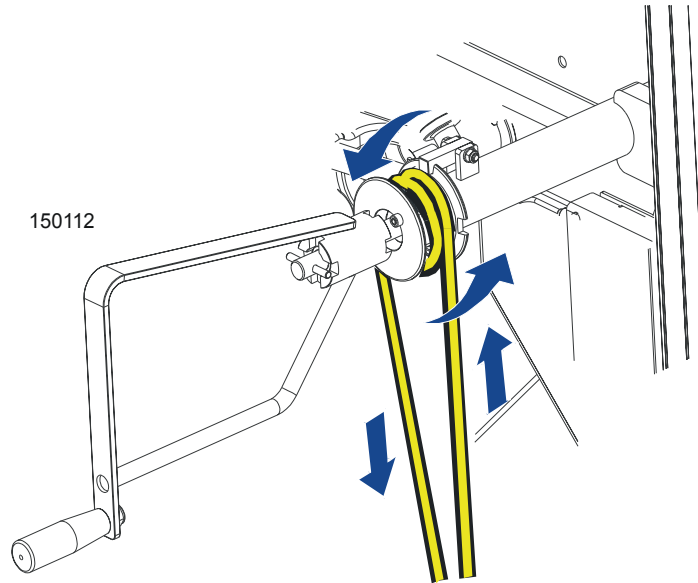

FIG. 2-17

5. Route the rope around the outer groove of the v-groove roller.

See Figure 2-18.

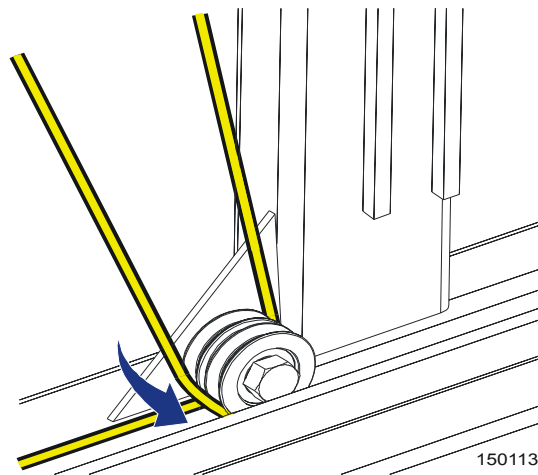

FIG. 2-18

6. Route the rope to the rear mounting bracket. Tie a knot in the end of the rope and insert into the mounting bracket. Position the knot in the rope so when installed to the rear

2 SAWMILL ASSEMBLY

Feed Rope Assembly

bracket, the rope is tight.

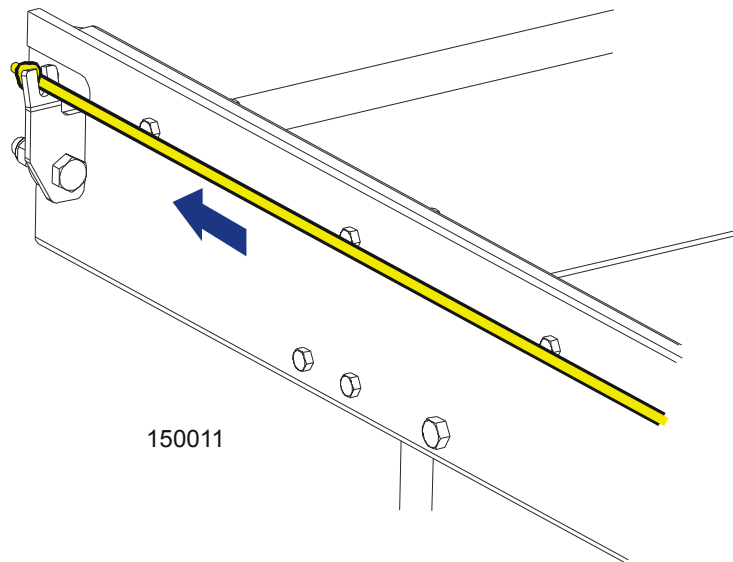

FIG. 2-18

2.7 Auxiliary Bed Rail

To install the auxiliary bed rail to a bed frame section, use the set of mounting holes provided between the two bed rails. Remove the existing bolt and lock nut that secures the track at this position. Use three hex head bolts and lock nuts to secure the bed rail to the bed section. Replace the track mounting bolt and lock nut.

See Figure 2-19.

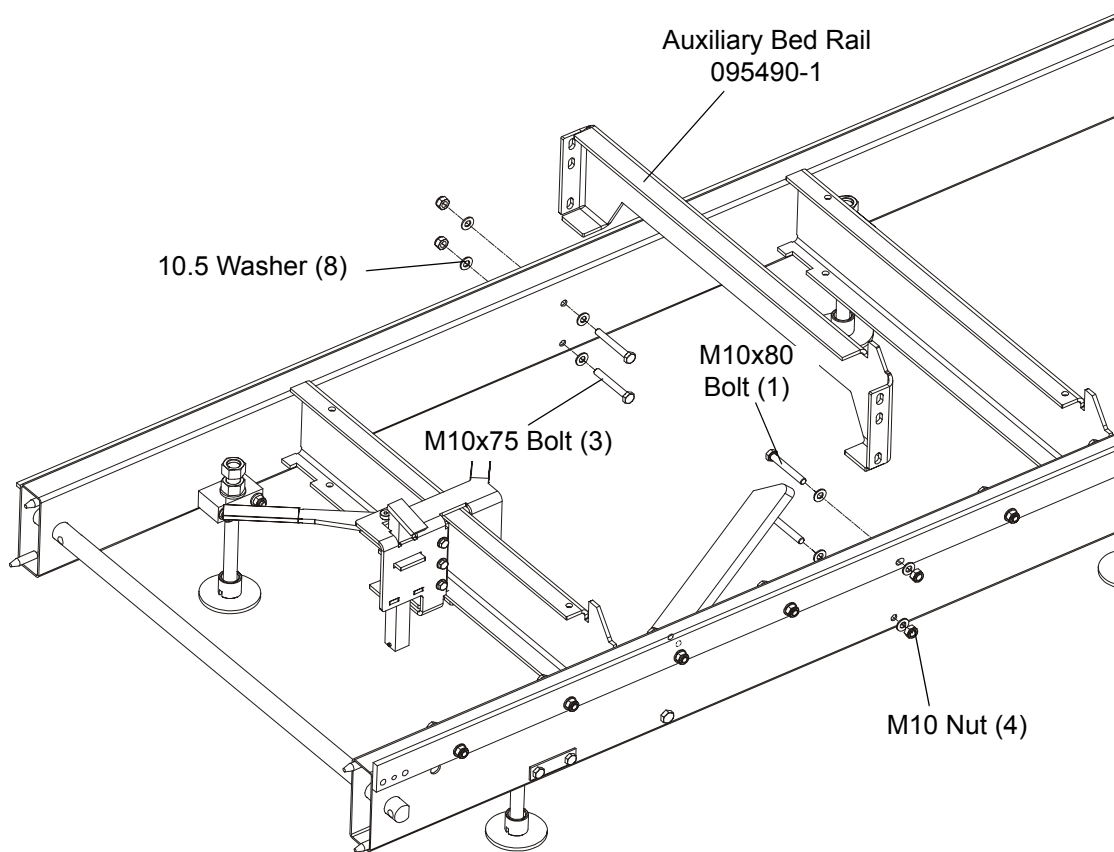

FIG. 2-19

SECTION 3 SETUP & OPERATION

3.1 Sawmill Setup

NOTE: The following setup procedure should be performed whenever the sawmill is moved or reassembled. If sawing problems occur and misalignment is suspected, [SECTION 6](#) for complete alignment instructions.

1. Adjust the frame legs so the sawmill appears level. If sawmill is on soft ground, use shims under the legs if necessary.
2. Run a string from the front bed rail to the rear bed rail near the operator's side of the frame. Place identical spacers between the string and the front and rear bed rails. Measure the distance between the string and the other bed rails. Adjust the frame legs until all bed rails measure the same distance from the string.
3. Loosen the auxiliary bed rail bolts and adjust the rail so it is the same distance from the string as the main bed rails. Retighten the bolts.

See Figure 3-1.

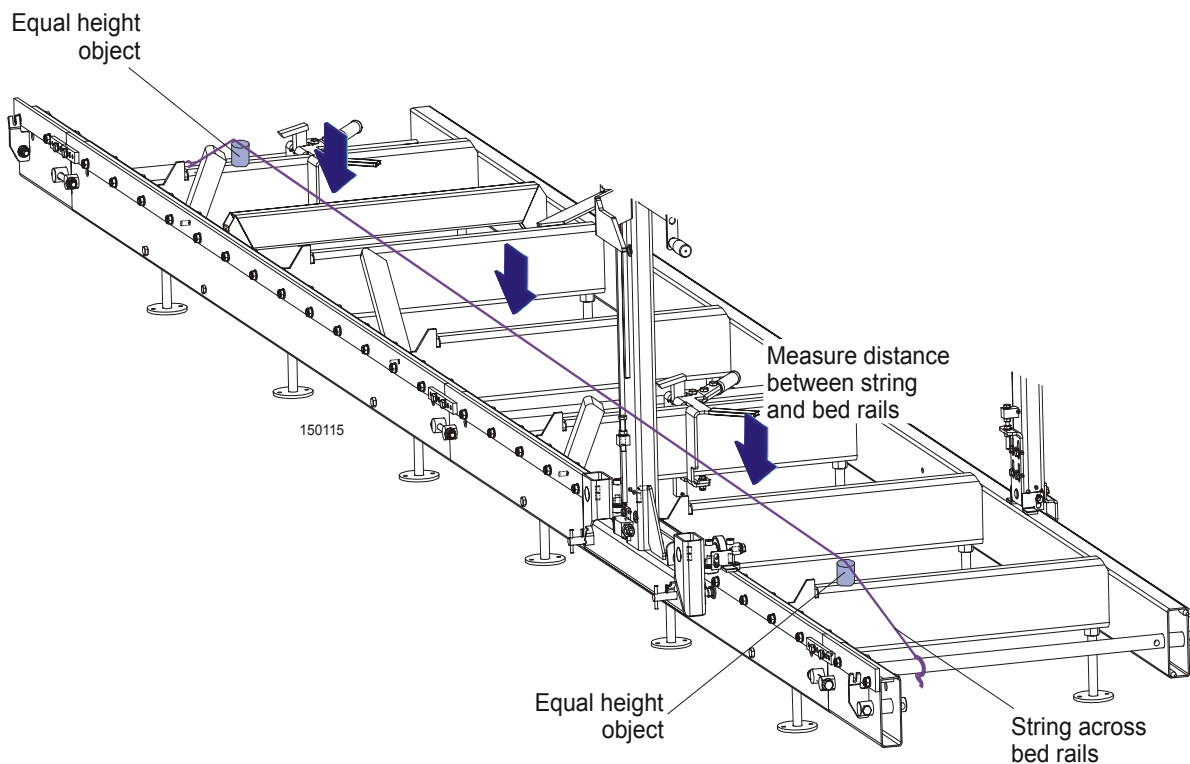

FIG. 3-1

4. Repeat the bed rail adjustment with the string at the other side of the sawmill frame.
5. Install a blade ([See Section 3.2](#) through [Section 3.4](#)) and move the saw carriage until the blade is positioned over the front bed rail.
6. The blade guide rollers should not touch and deflect the blade and the blade guide arm should be adjusted all the way out, away from the other blade guide.
7. Measure the distance from the bed rail to the bottom of the blade near the inside (fixed) blade guide.
8. Measure the distance from the bed rail to the bottom of the blade near the outside (movable) blade guide.

3 Setup & Operation

Sawmill Setup

See Figure 3-2. When the blade is parallel to the bed, it will measure the same distance from the bed rail at the inside and outside of the saw head. To adjust the saw head tilt, loosen the four mounting bolts of the idle side roller bracket, the two scraper mounting bolts and the two mounting bolts of the mast retaining bracket. Use the saw head adjustment nuts to move the outside of the saw head up or down.

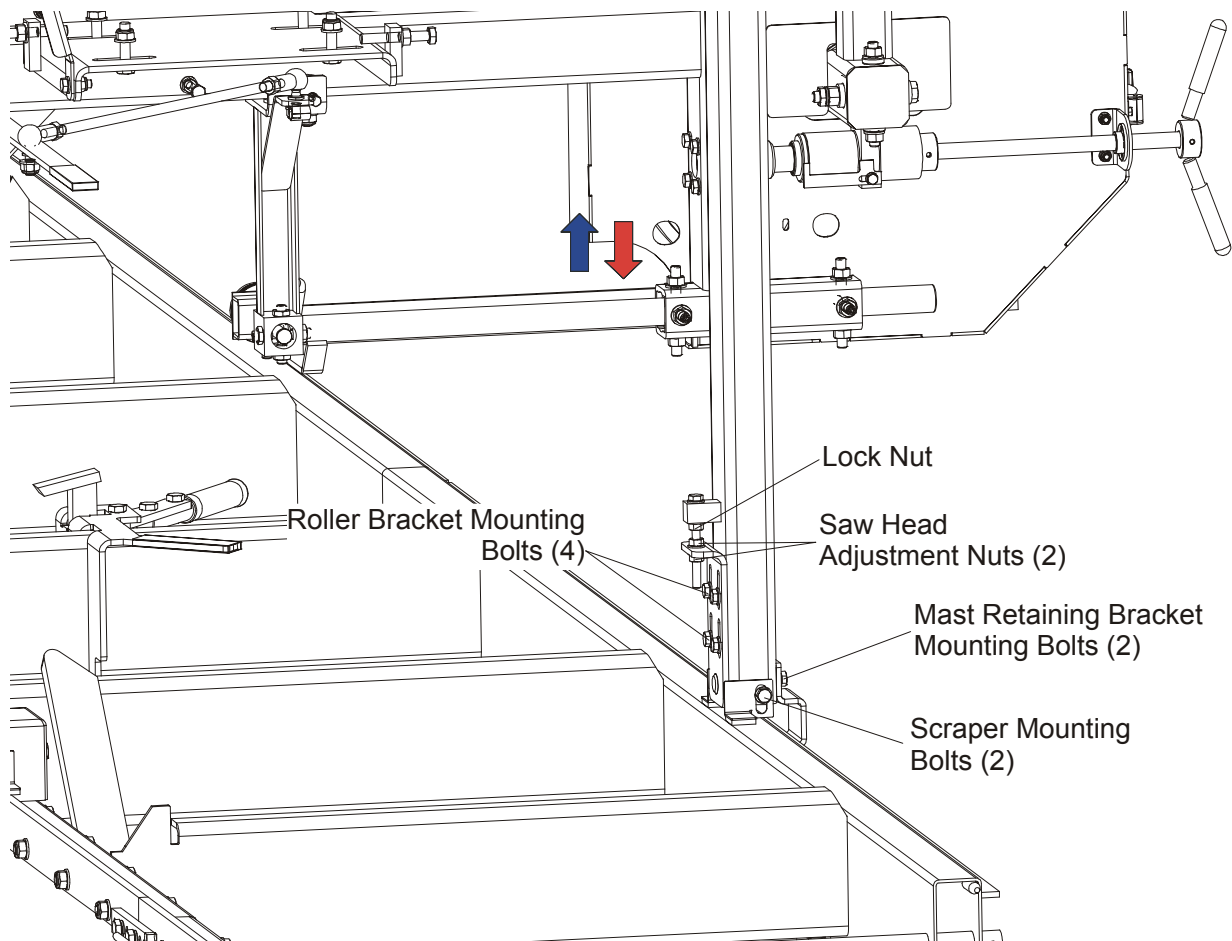

FIG. 3-2

9. Make sure the entire face of each slide pad makes contact with the mast. Use the adjustment nuts shown below to adjust the slide pads if necessary.

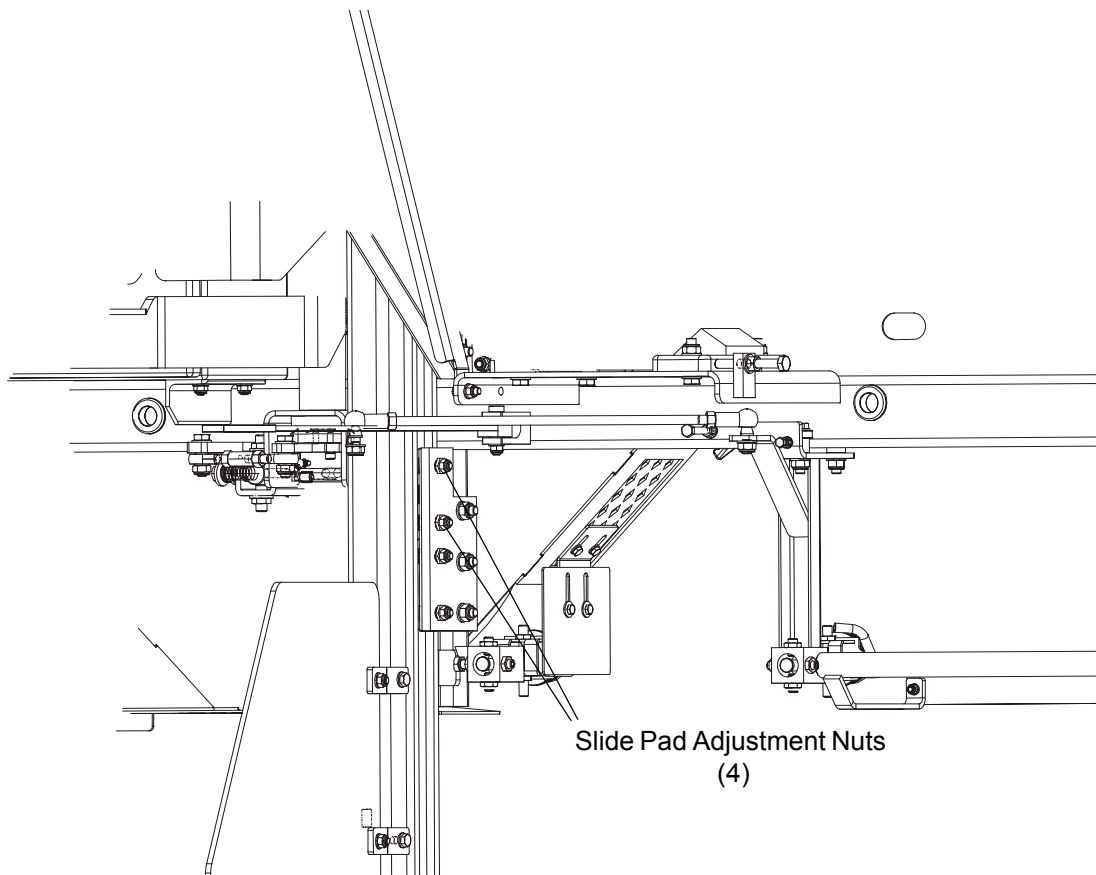

FIG. 3-2

10. Check the vertical alignment of each blade wheel using the blade guide alignment tool.
 - Attach the tool to the blade near the outer blade guide. Be sure the tool does not rest on a tooth or burr, and is lying flat on the blade.

See Figure 3-3.

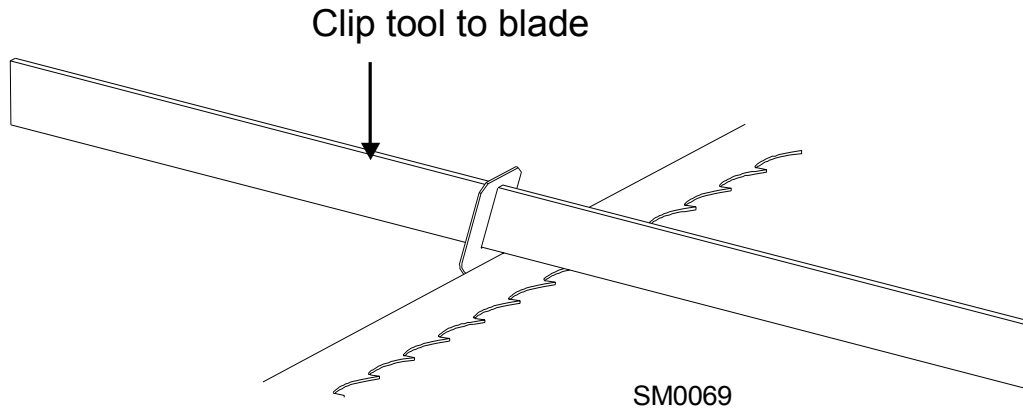

FIG. 3-3

- Move the saw head so the front end of the tool is positioned over the first bed rail. Measure from the bottom of the tool to the top surface of the bed rail.
- Move the saw head so the rear of the tool is positioned over the bed rail. Again, measure from the bottom of the tool to the bed rail.
- If the two measurements differ by more than 1/16" (1.5 mm), adjust the vertical tilt of the idle-side blade wheel. [See Figure 3-4.](#)
- Remove the tool from the blade and reattach it near the inner blade guide. Measure from the tool to the bed rail at both ends of the tool. If the measurements at the front and rear ends of the tool differ by more than 1/16" (1.5 mm), adjust the vertical tilt of the drive-side blade wheel. [See Figure 3-5.](#)

See Figure 3-4. To tilt the idle-side blade wheel up, loosen the bottom adjustment screw 1/2 turn. Loosen the nut on the top adjustment screw and tighten the screw. Tighten the top and bottom nuts.

To tilt the wheel down, loosen the top adjustment screw 1/2 turn. Loosen the nut on the bottom adjustment screw and tighten the screw. Tighten the top and bottom nuts.

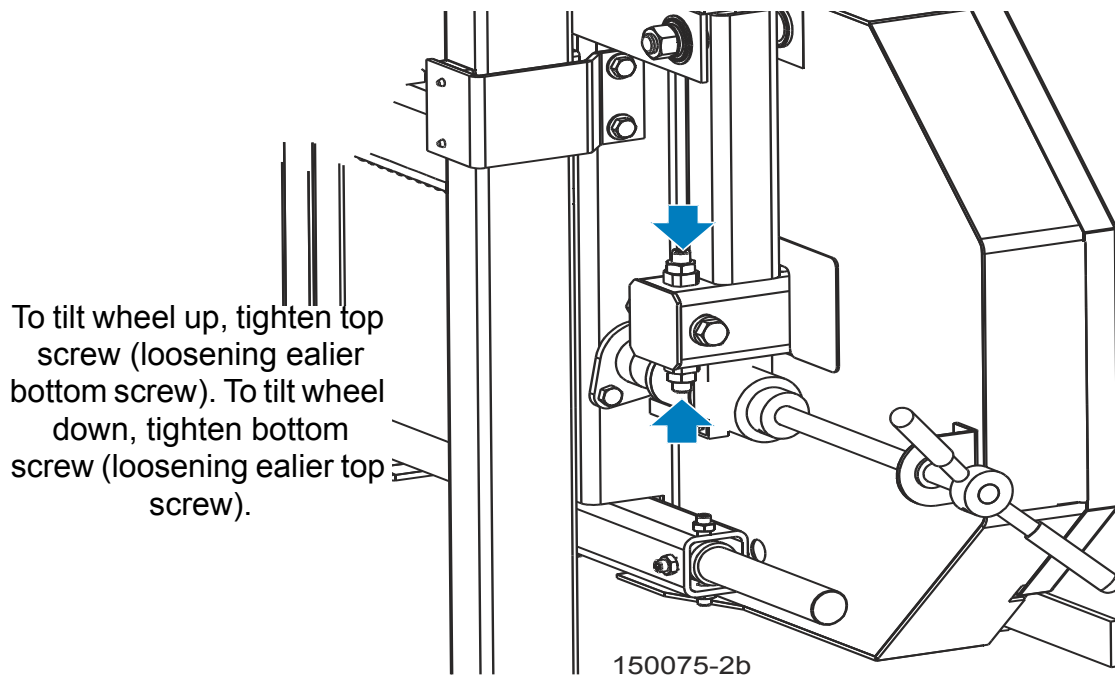

FIG. 3-4

3

Setup & Operation

Sawmill Setup

See Figure 3-5. To tilt the drive-side blade wheel down, loosen the top adjustment screw, loosen the nut on the bottom adjustment screw and tighten the bottom screw. Tighten the top and bottom nuts.

To tilt the wheel up, loosen the bottom adjustment screw, loosen the nut on the top adjustment screw and tighten the top screw. Tighten the top and bottom nuts.

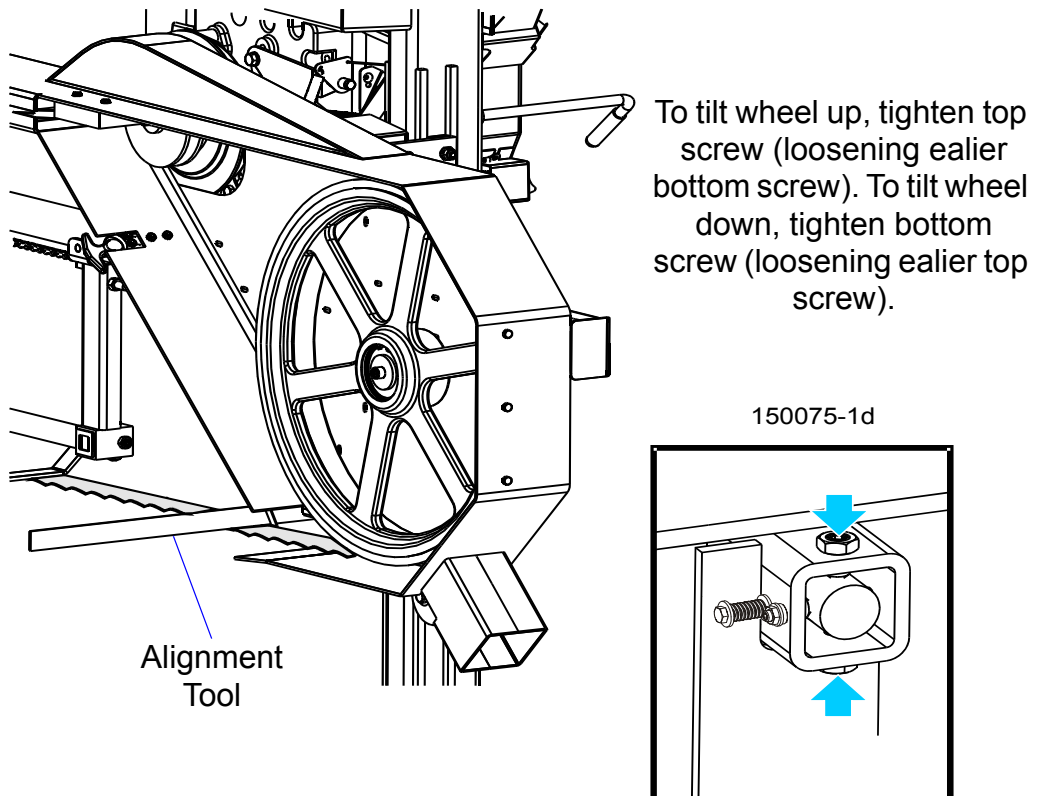

FIG. 3-5

- Recheck the vertical alignment of each blade wheel. Readjust if necessary.

11. Adjust the spacing between each blade guide roller flange and the back of the blade. [See Section 6.9](#)
12. Adjust the horizontal angle of the blade guides. [See Section 6.10](#)
13. Adjust the blade deflection ([See Section 6.7](#)) and the vertical angle of the blade guides ([See Section 6.8](#)).

HINT: It is best to preliminarily set the blade deflection so that it is 3 - 4 mm, then adjust the blade guides in the vertical plane and make the final adjustments to the blade deflection. The proper blade deflection is 6 mm. After adjusting the blade deflection, recheck the vertical alignment of the blade guides and adjust if necessary.

14. Install the blade height scale. To do that, first measure the distance from the bottom edge on a down-set tooth of the blade to the top of the bed rail. Then stick the blade height scale on the mounting bracket so that it indicates the true distance from the blade to the bed. Adjust the scale if necessary. [See Section 6.12](#).
15. Bolt the blade guide guard so that its bottom edge is about 5 mm above the blade.

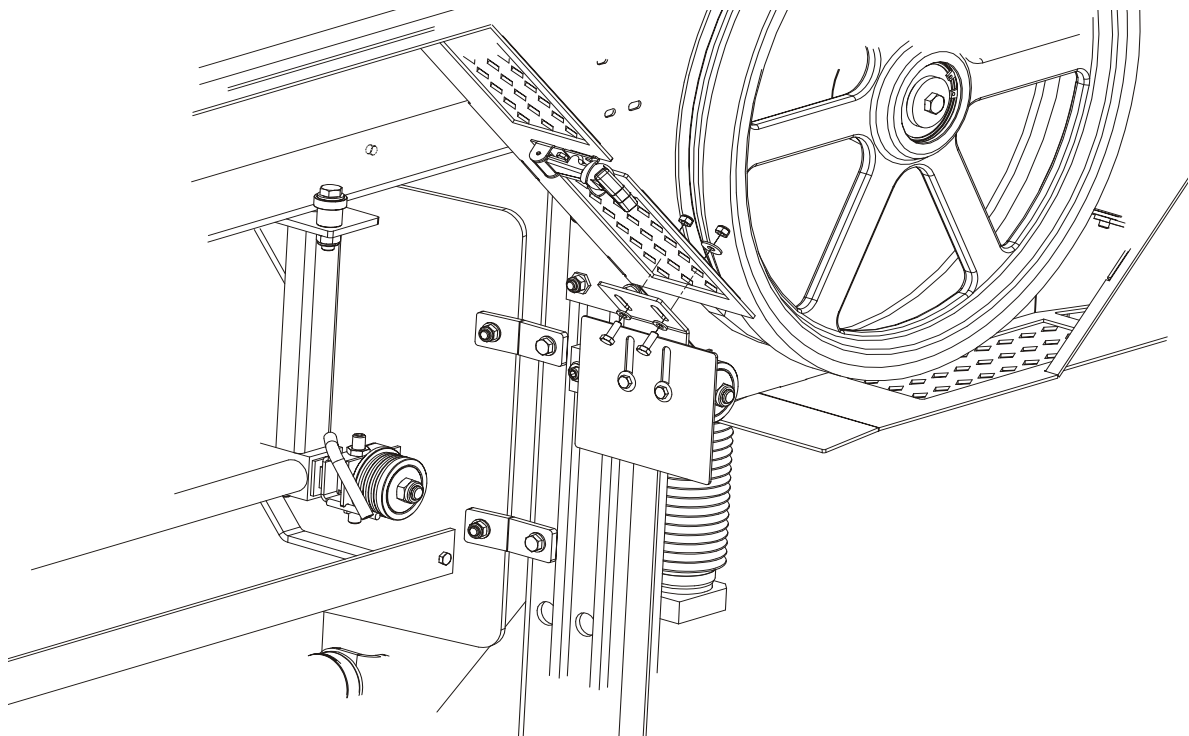

FIG. 3-5

3 Setup & Operation

Sawmill Setup

16. Adjust the cam engaging the limit switch as well as the saw head stop bolt so that the saw head stops moving at its lower travel limit, i.e. at the height of 25 mm above the bed.

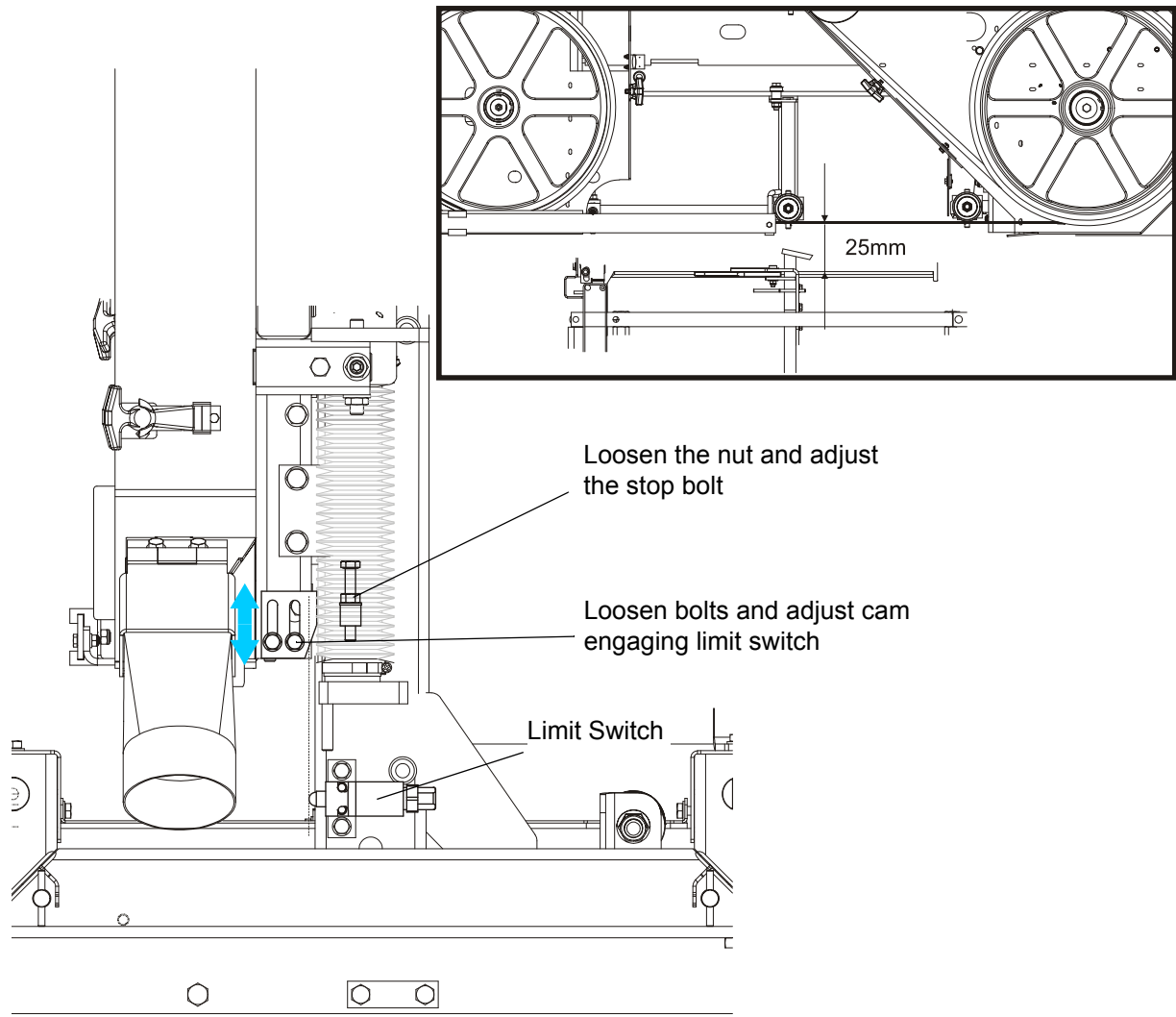

FIG. 3-5

3.2 Replacing The Blade



DANGER! Always disengage the blade and shut off the sawmill motor before changing the blade. Disconnect the power supply using the main switch. Failure to do so will result in serious injury.



WARNING! Always wear gloves and eye protection when handling bandsaw blades. Changing blades is safest when done by one person! Keep all other persons away from area when coiling, uncoiling, carrying or changing a blade. Failure to do so may result in serious injury.

Adjust the blade guide arm all the way open.

Open the blade housing cover that cover the blade wheels. Turn the blade tension handle to release the blade tension until the wheel is pulled in and the blade is lying loose in the blade housing. Lift the blade out of the blade housing.

Install a new blade on the blade wheels. When installing the blade, make sure the teeth are pointing the correct direction. The teeth located between the blade guide assemblies should be pointing toward the sawdust chute.

Position 1 1/4" wide blades on the wheels so the gullet is 1/8" (3.0 mm) out from the front edge of the wheel. Position 1 1/2" wide blades on the wheels so the gullet is 3/16" (4.5 mm) out from the front edge of the wheel.

Close the blade housing cover.

Next, turn the tension handle until the blade is tensioned correctly.

3 Setup & Operation

Tensioning The Blade

3.3 Tensioning The Blade

See **Figure 3-6**. Turn the blade tension handle clockwise to compress the rubber spring and tension the blade. Check the blade tension occasionally when adjusting the cant control or while cutting. As the blade and belts heat up and stretch, the blade tension will change. Also, ambient temperature changes can cause tension to change. Adjust the tension handle as necessary to keep the rubber spring washer aligned with the indicator.

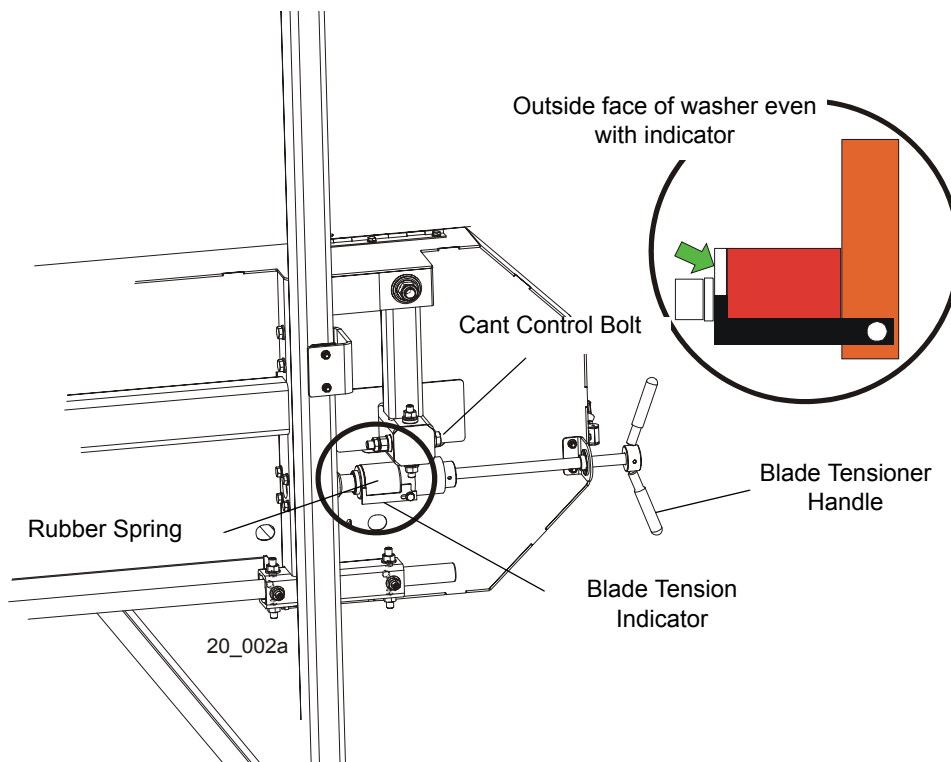

FIG. 3-6



CAUTION! Release the blade tension when the mill is not in use.

3.4 Tracking The Blade

1. Make sure the blade housing cover is closed and all persons are clear of the blade.
2. Start the motor for a moment until the blade positions itself on the wheels.



WARNING! Do not spin the blade wheels by hand. Spinning the blade wheels by hand may result in serious injury.

3. Turn off the engine and check the position of the blade on the blade wheels.

See **Figure 3-7**. Position 1 1/4" wide blades so the gullet is 1/8" (3.0 mm) out from the edge of the blade wheel ($\pm 1/32$ [.75 mm]).

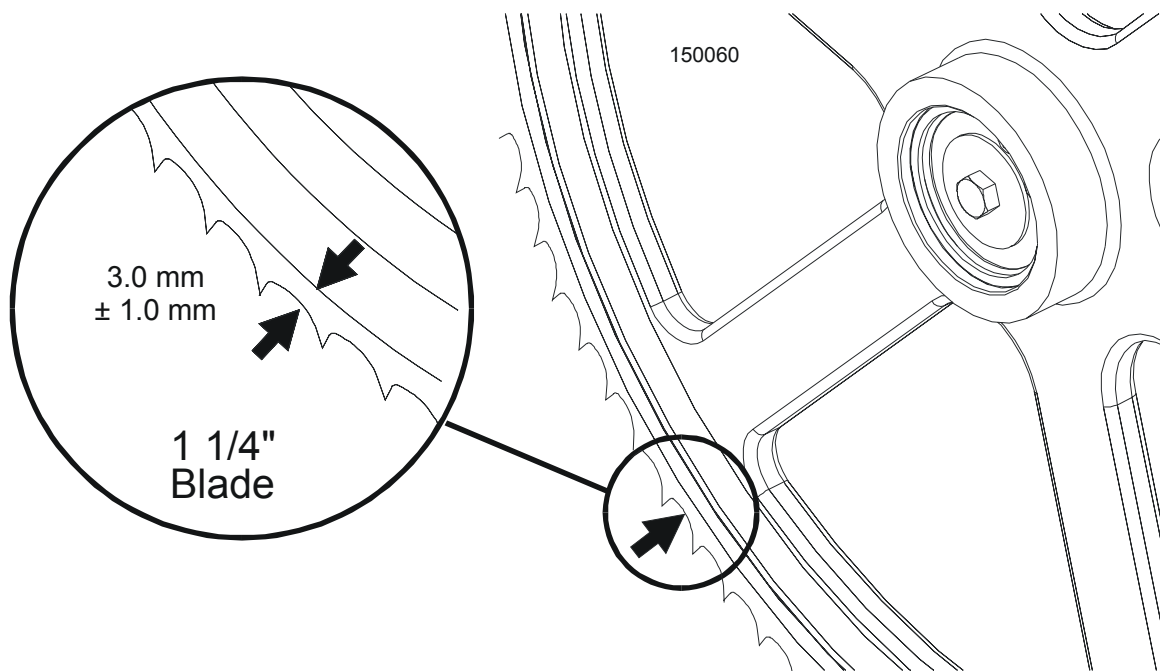

FIG. 3-7

See **Figure 3-8**. To adjust where the blade travels on the blade wheels, use the cant control bolt.

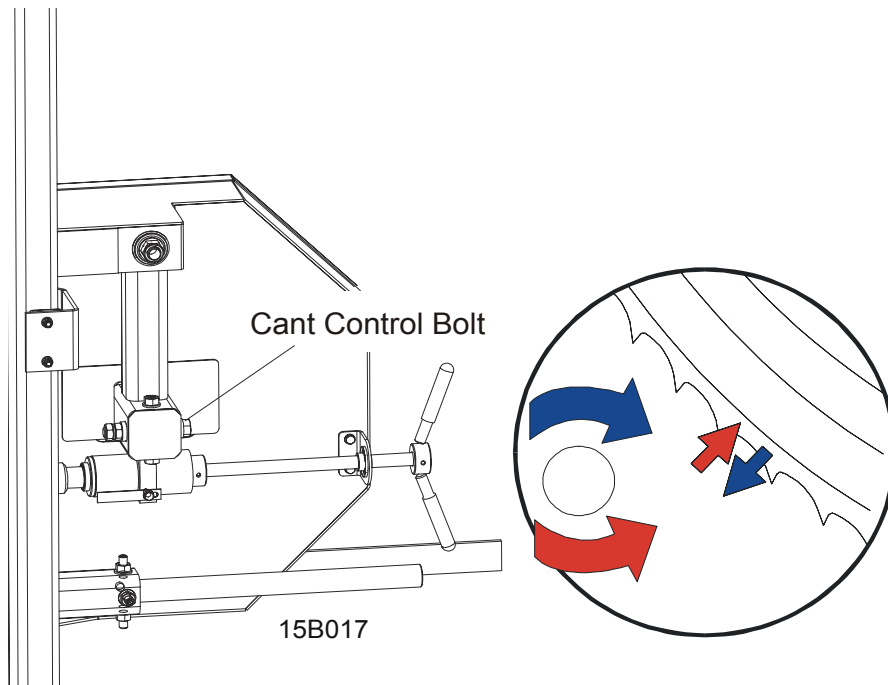

FIG. 3-8

If the blade is too far out, back the blade onto the wheel by turning the cant control counterclockwise. If the blade is too far in, turn the cant control clockwise until the gullet of the blade is the correct distance from the front edge of the wheel.

4. Adjust the blade tension if necessary to compensate for any changes that may have occurred while adjusting the cant control.
5. Close the blade housing cover.



DANGER! Make sure all guards and covers are in place and secured/closed before operating the sawmill. Failure to do so may result in serious injury.

IMPORTANT! After aligning the blade on the wheels, always double-check the blade guide spacing and location. ([SECTION 6](#) for more information.)

3.5 Starting The Motor

See the appropriate manual supplied with your specific motor configuration for starting and operating instructions.



IMPORTANT! When starting the machine for the first time, check that main motor rotation direction is as indicated by the arrow located on the motor body (fan guard). If the rotation direction is incorrect, invert the phases in the phase inverter located in the power socket (electric box). Setting the phases in the phase inverter correctly will ensure correct rotation directions of all sawmill motors.



DANGER! Make sure all guards and covers are in place and secured/closed before operating the sawmill. Failure to do so may result in serious injury.



DANGER! Always be sure the blade is disengaged and all persons are out of the path of the blade before starting the engine or motor. Failure to do so will result in serious injury.



WARNING! Always wear eye, ear, respiration, safety clothing and foot protection when operating the sawmill. Failure to do so may result in serious injury.

3.6 Loading, Turning, And Clamping Logs

To Load Logs

1. Move the cutting head to the front end of the frame.

 **CAUTION!** Before loading a log, be sure the cutting head is moved far enough forward so the log does not hit it. Failure to do so may result in machine damage.

2. Adjust the log clamps all the way down and move them toward the loading side of the sawmill frame.

 **CAUTION!** Be sure the log clamps are all the way down before loading a log onto the bed. Failure to do so may result in machine damage.

3. Raise the side supports on the sawmill bed to prevent the log from falling off the side of the bed.
4. Place the optional loading ramps in the frame brackets that will evenly support the length of the log.

See Figure 3-9.

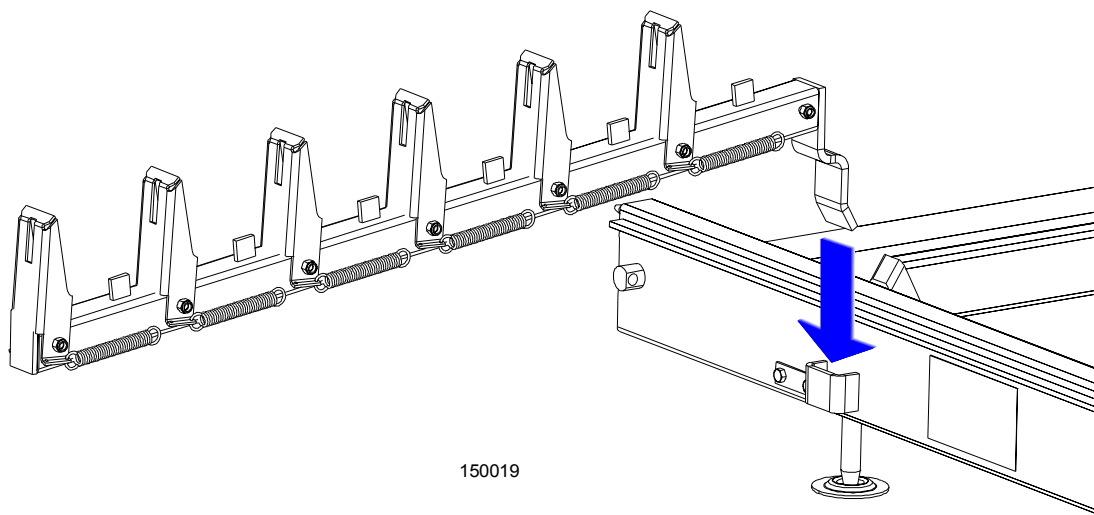

150019

FIG. 3-9

5. Position the log at the foot of the ramps.
6. Use a cant hook to roll the log up the ramps and onto the sawmill bed. Position the log against the side supports.
7. Remove the log ramps and set aside.



CAUTION! The saw head will hit the spring-loaded ramp stops when adjusted for low cuts. Remove the loading ramps before sawing to prevent damage to the saw head and/or blade guide arm.

If you did not purchase the optional loading ramps, use boards for ramps or use log loading equipment to load the log on the sawmill bed.

To Turn Logs

1. Use a cant hook to spin the log against the side supports until it is turned the way you want it for the first cut.

To Clamp Logs

1. Position the clamps against the log, far enough down so they are below your cuts on a given side of the log. Using the clamp handles move the log firmly against the side supports.

3 Setup & Operation

Loading, Turning, And Clamping Logs

See Figure 3-10.

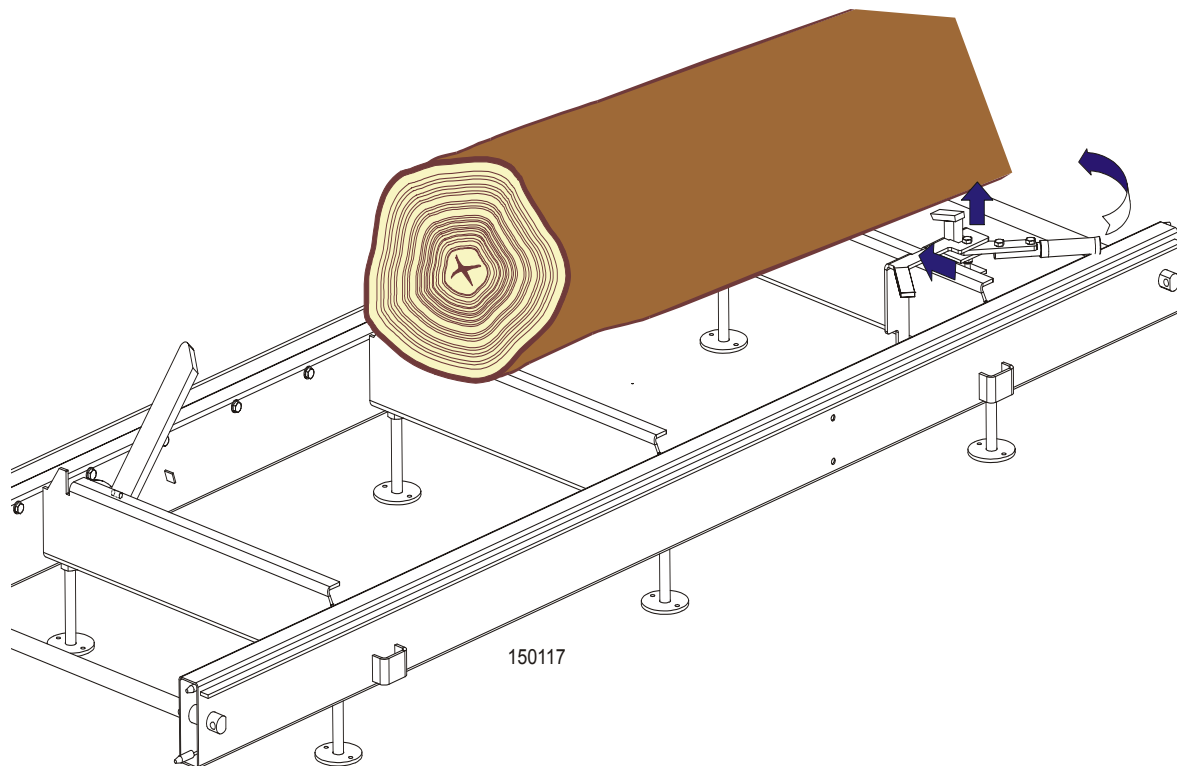

FIG. 3-10

2. Make sure the side supports are positioned low enough for the blade to pass over them. If they are not, back the clamps off slightly and push the side supports down until they are positioned below the height of your last cut on a given side of the log.

To Level A Tapered Log

Use shims or the optional wedge to raise either end of a tapered log, if desired.

Shim one end of the log until the heart of the log measures the same distance from the bed rails at each end of the log.

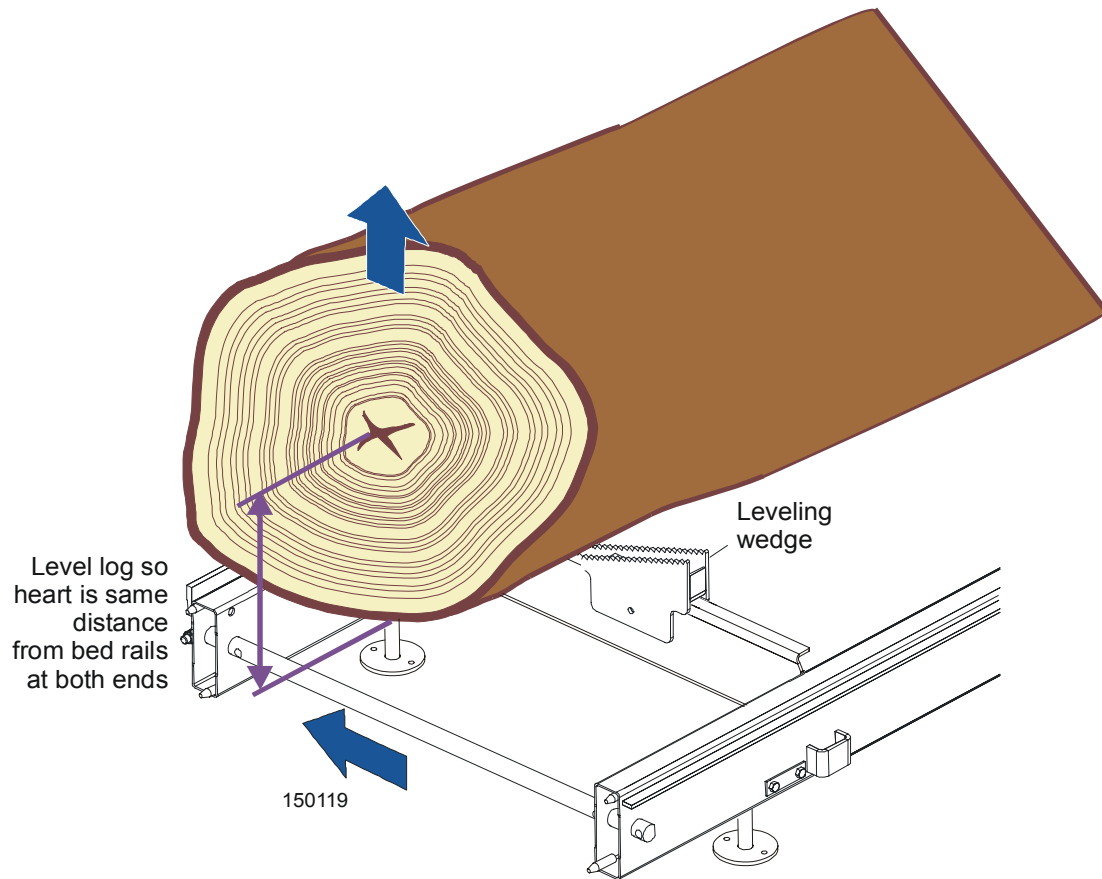

FIG. 3-10

3.7 Up/Down Operation

1. Install a blade, if needed, and check for correct blade tension. ([See Section 3.3](#)).

Set the cutting head to the desired height. (The blade height scale shows the height of the blade above the bed rails.)

See Figure 3-11. Use the up and down buttons shown below to raise or lower the cutting head.

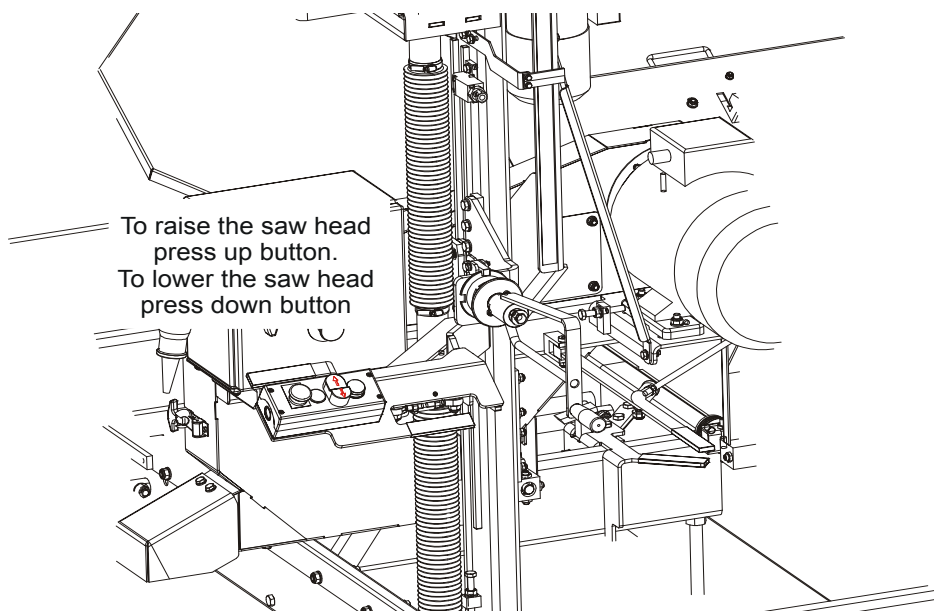

FIG. 3-11

CAUTION! DO NOT try to force the carriage above the 27" (68 cm) mark or below the 1" (2.54 cm) mark. Damage to the up/down system may result.

3.8 Blade Guide Arm Operation

1. Look down the length of the log to see its maximum width. The outer blade guide roller should be adjusted to clear the widest section of the log by less than 1" (25.4 mm).
2. Use the blade guide arm handle to adjust the outer blade guide as necessary. Move the blade guide arm handle right to move the arm out. Move the handle left to move the arm in.

See Figure 3-12.

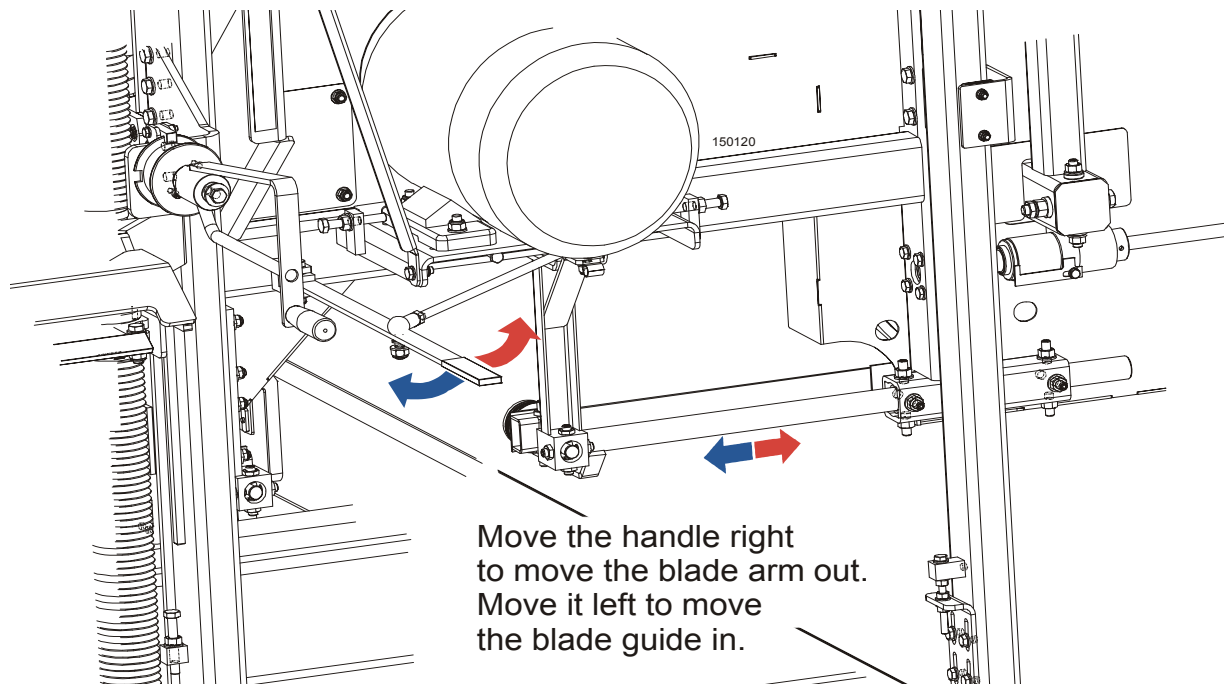

FIG. 3-12

3.9 Blade Drive Operation



DANGER! Make sure all guards and covers are in place and secured/closed before operating the sawmill. Failure to do so may result in serious injury.

Be sure the blade housing cover is in place and secured before starting the engine or motor. Use the rubber latches to fasten the blade housing cover shut. If the blade housing cover is not closed and secured, the safety switch located on it interrupts the ignition circuit and the motor/engine cannot be started. If the cover is opened during the mill operation, the engine/motor will be stopped.

Electric Motors Only

1. Clear any loose objects from the area of the blade, motor, and drive belt.
2. Make sure the clamps and side supports are positioned low enough for the blade to pass over them. Make sure the log is clamped securely.
3. Start the motor as instructed in the motor manual.

See Figure 3-13. To engage the blade, perform the following steps:

- Turn the main switch on the electrical box to the ON position.
- Press **AND HOLD** the green safety button on the control box.

NOTE: Keep the safety button pressed all the time the blade is driven. If the safety button is released, the motor stops and it needs to be restarted.

- Press the START button on the control box to start the motor.

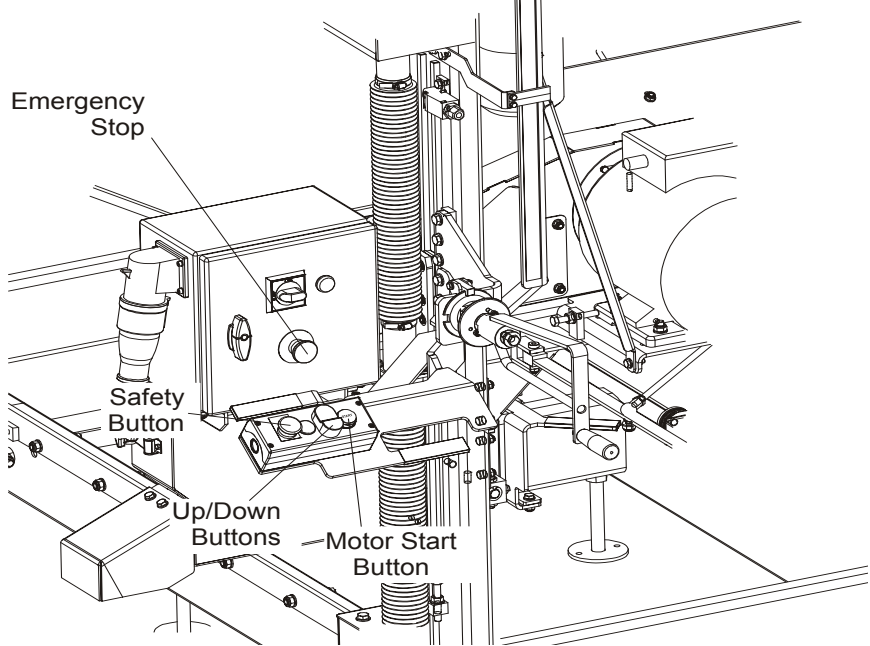

FIG. 3-13

3.10 Feed Operation

The feed system includes a hand crank to move the carriage forward or backward. The speed at which the carriage travels forward depends on how fast you turn the feed crank.

1. To move the carriage forward, push the crank handle in to engage the screw heads and rotate the feed crank clockwise.

See Figure 3-14.

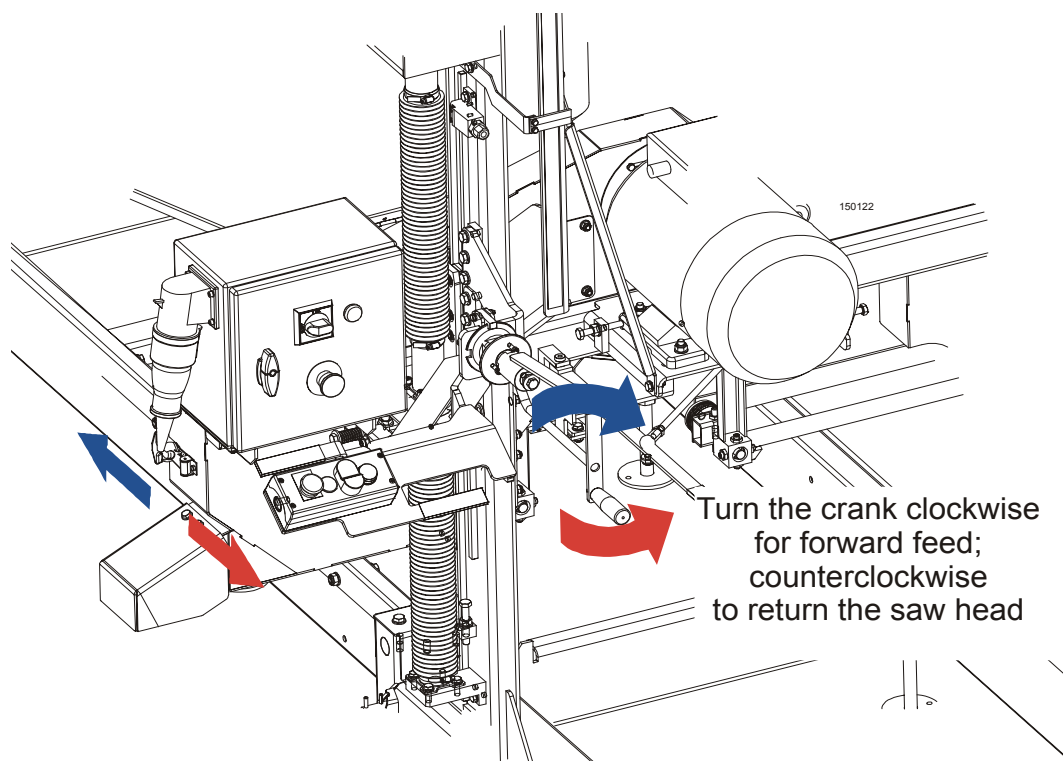

FIG. 3-14

HINT: To get a straight cut in the first part of the board, feed the blade into the log at a slow speed. This stops the blade from flexing and dipping up or down. Use a slow speed until the whole width of the blade has entered the cut. Then increase the feed rate as desired. Maximum feed rate varies with width and hardness of the wood. Over-feeding results in blade and drive belt wear, and also produces a wavy cut.

2. To move the cutting head backward, rotate the feed crank counterclockwise, or pull the saw head back. Always disengage the blade before returning the cutting head and raise the head slightly to make sure the blade clears the log.



CAUTION! Be sure to stop the blade when returning the cutting head. This will not only prevent the blade from being pulled off and ruined by a wood sliver, but also will increase the life of the blade.

HINT: Try to stop the blade while the heel of the blade is still on the log. Then bring the carriage back without adjusting the blade up. This lets you keep the blade at the current height setting so you can make the next blade height adjustment more quickly.

HINT: You can also move the cutting head by hand, using the brackets on the control box. When the manual feed is used it is not necessary to install the feed crank, rope, v-groove rollers and rope mounting brackets.

3.11 Cutting The Log

The following steps guide you through normal operation of the Wood-Mizer sawmill.

1. Once the log is placed where you want it and clamped firmly, position the blade close to the end of the log.
2. Use the blade height scale to determine where to make your first cut ([See Section 3.13](#)). The blade height scale will help you to do this. Set the blade to the desired height with the up/down buttons. Make sure that the blade will clear all side supports and clamps. Adjust the outer blade guide to clear the widest section of the log by moving the blade guide arm handle. ([See Section 3.8](#).)
3. Make sure all covers and guards are in place and secured. Start the engine.
4. Start the water lube if necessary to prevent sap buildup on the blade. [See Section 3.14](#).
5. Feed the blade into the log slowly. ([See Section 3.10](#).) Once the blade completely enters the log, increase the feed rate as desired. Always try to cut at the fastest speed you can while keeping an accurate cut. Cutting too slowly will waste blade life and lower production!
6. As you get to the end of the log, slow down the feed rate. When the teeth exit the end of the log, release the safety button on the control box. Remove the slab that you have just cut from the log.
7. Use the feed crank to return the cutting head to the front of the mill. Always disengage the blade before returning the cutting head for the next cut.
8. Repeat until the first side of the log is cut as desired. Set aside the usable flitches (boards with bark on one or both sides). You can edge them on the mill later.

3

Setup & Operation

Cutting The Log

9. Remove the leveling wedge if it was used. Release the clamps and turn the log 90 or 180 degrees. Make sure the flat on the log is placed flat against side supports if turned 90 degrees. Make sure it is placed on bed rails if turned 180 degrees. If the log was turned 90 degrees and you are using the wedge to compensate for taper in the log, use the wedge again to adjust the heart of the log parallel with the bed.
10. Repeat the steps used to cut the first side of the log until the log is square. Cut boards from the remaining cant by adjusting the blade height for the thickness of boards that you want.

Example: Remember that the blade cuts a 1/16 - 1/8" (1.6 - 3.2 mm) wide kerf. If you want 1" (25 mm) thick boards, lower the carriage 1 1/16 - 1 1/8" (27 - 29 mm) for each board.

3.12 Edging

The following steps guide you through edging boards on the Wood-Mizer sawmill.

1. Raise the side supports to 1/2 the height of the flitches, or the boards that need to be edged.
2. Stack the flitches on edge against the side supports.
3. Clamp the flitches against the side supports halfway up the flitch height. (Wider flitches should be placed to the clamp side. When they are edged, flip them over to edge the second side without disturbing the other flitches or without having to pull them from the middle of the stack.)
4. Adjust the blade height to edge a few of the widest boards.
5. Loosen the clamps and turn the edged boards over to edge the other side.
6. Repeat steps 2-4.
7. Loosen the clamps and remove the boards that have good clean edges on both sides. Clamp the remaining flitches and repeat steps 2-5.

3.13 Blade Height Scale

See Figure 3-15. The blade height scale is mounted on the vertical mast. It includes:

- a blade height indicator
- centimeter scale (or quarter inch scale).

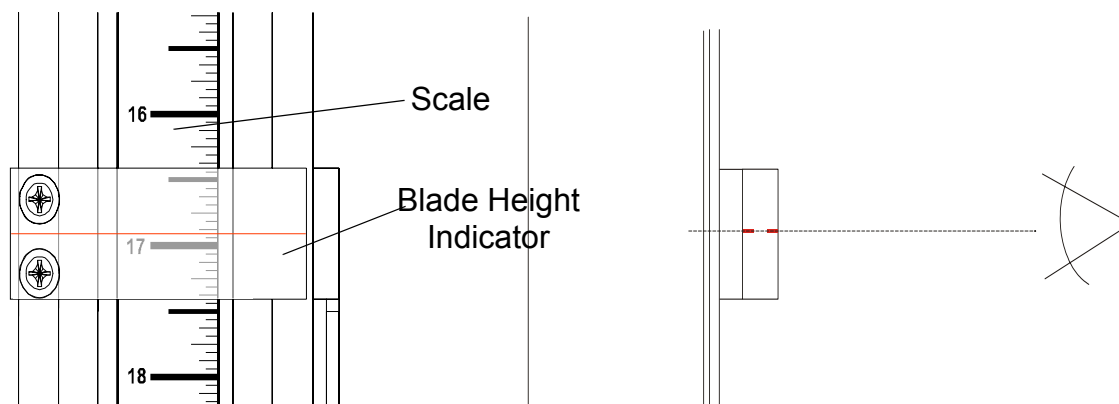

FIG. 3-15

Blade Height Indicator

The blade height indicator has two horizontal, red lines on both sides. Readings should be taken with eyes level with the indicator, when the two red lines are in line. This will allow to avoid the parallax error (different scale readings depending on the angle of vision).

The Scale

The horizontal red line on the blade height indicator shows how many centimeters the bottom of the blade is above the bed of the mill. If you know the height of your blade at each cut, you can determine the thickness of lumber you are sawing.

Example: You want to cut 25 mm random width boards from a log. Position the blade for the first cut. Move the carriage to an even measurement on the scale. Make a trim cut. Return the carriage for the second cut and lower it 29 mm below the original measurement. (The extra 3 mm allows for saw kerf and shrinkage of the lumber.)

The yellow area on the scale identifies where the blade could encounter a side support or log clamp. Check that these items are below the blade level before sawing.

The Quarter Scale

See Table 3-1. four sets of marks. Each set represents a specific lumber thickness. Saw kerf and shrinkage allowance are included, but actual board thickness will vary slightly depending on blade thickness and tooth set.

To choose which scale to use, determine what finished thickness you want to end up with. The Grade Hardwood Quarter Scale provides thicker finished boards usually required by commercial buyers. The Standard Quarter Scale allows for kerf and shrinkage of finished boards suitable for most custom applications. Always check with your customer before you saw to determine what actual finished thickness is required.

Standard Quarter Scale		Grade Hardwood Quarter Scale	
Scale	Actual Board Thickness	Scale	Actual Board Thickness
4/4	1" (25 mm)	4/4	1 1/8" (29 mm)
5/4	1 1/4" (32 mm)	5/4	1 3/8" (35 mm)
6/4	1 1/2" (38 mm)	6/4	1 5/8" (41 mm)
8/4	2" (51 mm)	8/4	2 1/8" (54 mm)

TABLE 3-1

To use the quarter scale, look at the blade height indicator. **Example:** You want to cut 1" (25 mm) (4/4) random width boards from a log. Position the blade for the first cut. Make a trim cut. Return the carriage for the second cut. Now, instead of having to measure down 1 1/8" (29 mm) on the inch scale, you can simply lower the blade so the indicator is aligned with the next 4/4 mark on the quarter scale. Turn the log 90 degrees and repeat.

3.14 Water Lube Operation

The Water Lube System keeps the blade clean. Water flows from a 5-gallon (18.9 liter) bottle through a hose to the blade guide where the blade enters the log. A valve in the bottle cap controls the amount of water flow.

See **Figure 3-16**. Install the water bottle at the top of the vertical mast.

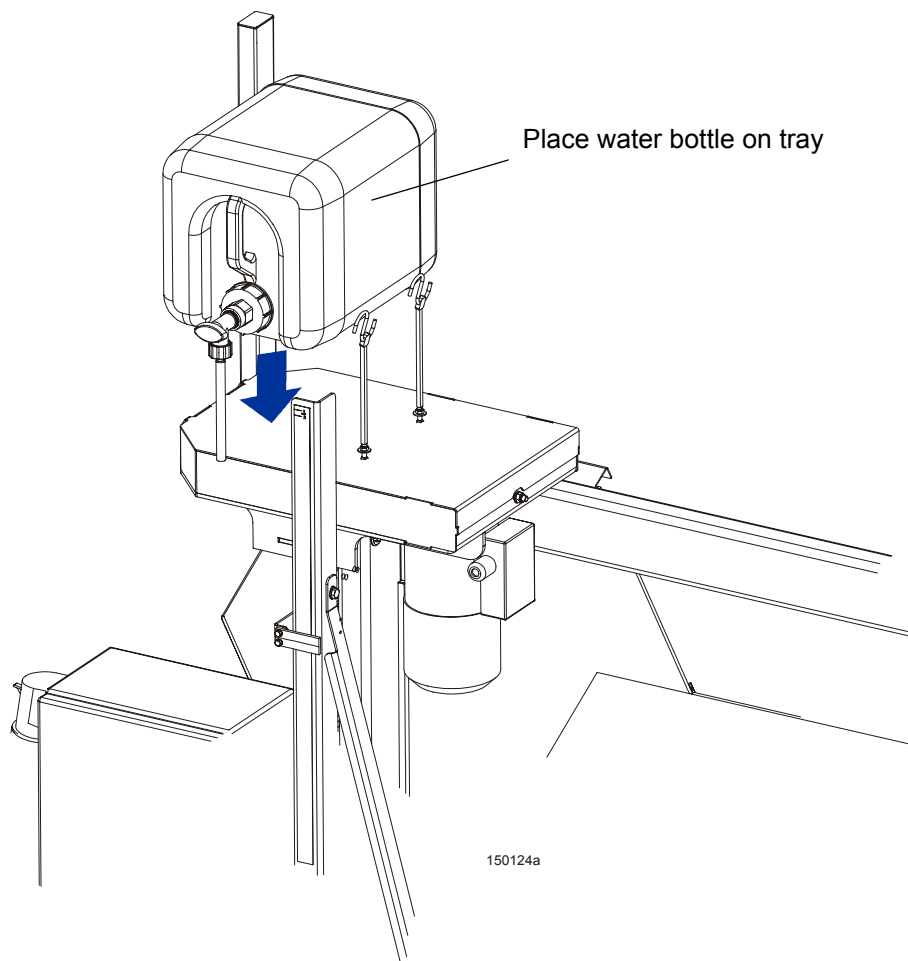

FIG. 3-16

See Figure 3-17. Route the water hose as shown below. Secure it with the provided hose clamps at the locations marked with red points in the figure.

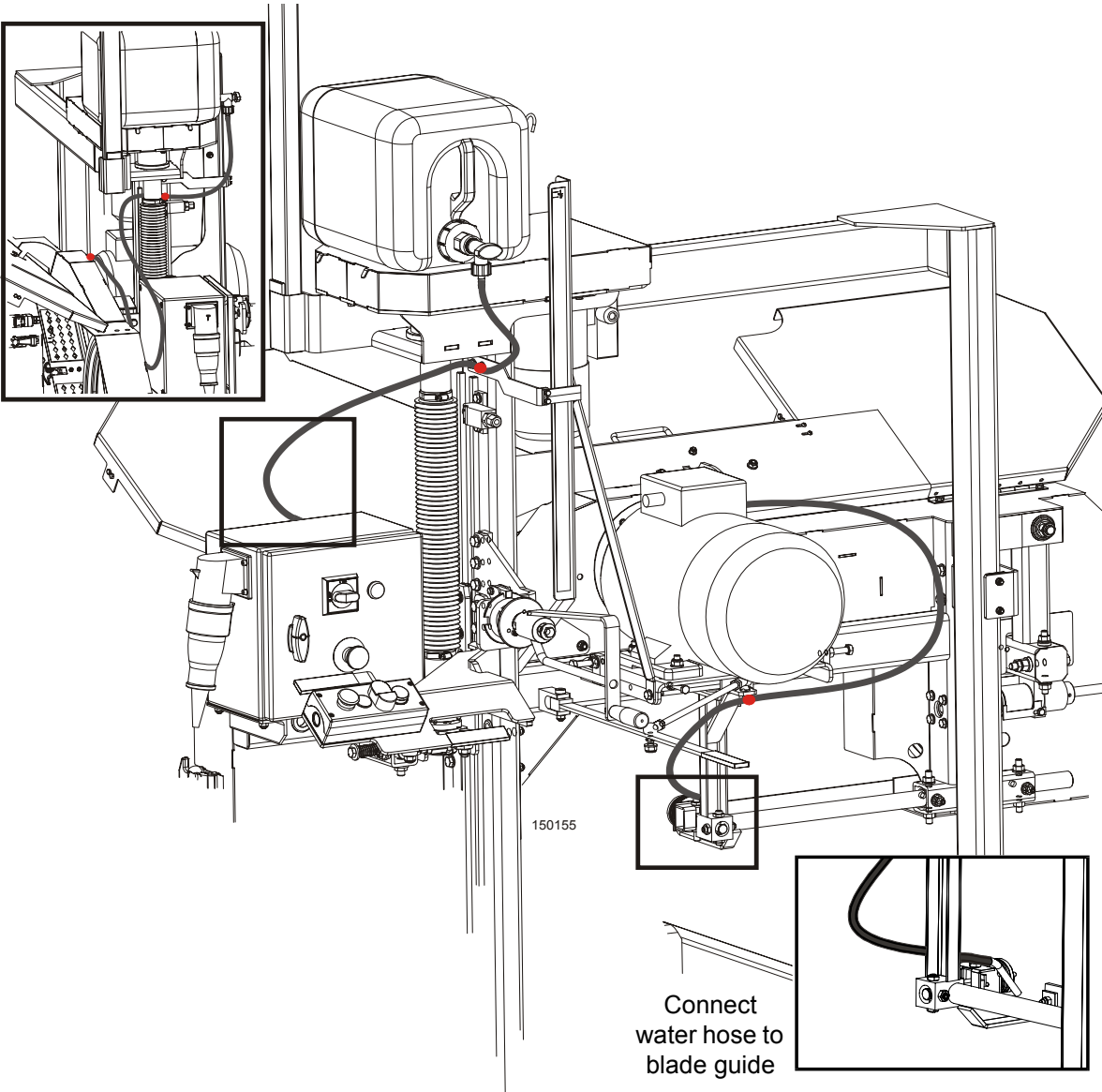

FIG. 3-17

See Figure 3-18. Open the valve on the water bottle to start water flow to the blade.

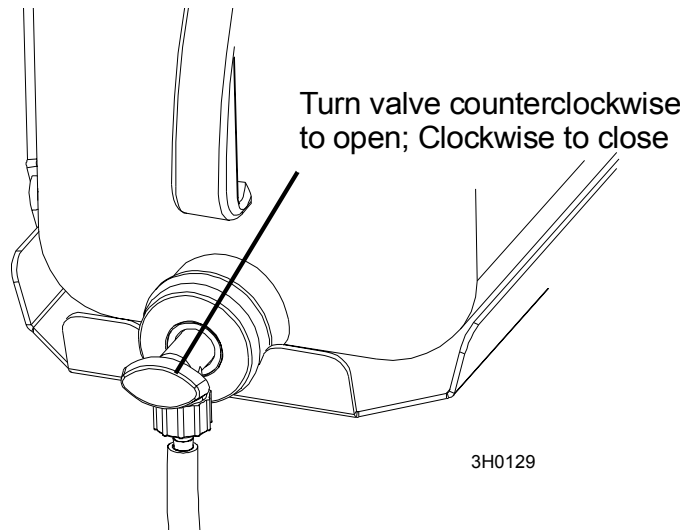



FIG. 3-18

Not all types of wood require the use of the Water Lube System. When it is needed, use just enough water to keep the blade clean. This saves water, and lowers the risk of staining the boards with water. Usual flow will be 1-2 gallons (3.8-7.6 liters) per hour. A squirt of liquid dishwashing detergent in the water bottle will help clean the blade when cutting wood with a high sap content.

 **WARNING!** Use ONLY water with the water lube accessory. Never use flammable fuels or liquids. If these types of liquids are necessary to clean the blade, remove it and clean with a rag. Failure to do so may result in serious injury or death.

Before removing the blade, engage the clutch/brake lever (sawmills with a gasoline engine only). Let the blade spin with water running on it for about 15 seconds. This will clean the blade of sap buildup. Wipe the blade dry with a rag before storing or sharpening.

If you are sawing in freezing temperatures, remove the water lube bottle from the sawmill when done sawing and store it in a warm place. Blow any remaining water from the water lube hose.

3.15 Transporting the Sawmill

The assembled sawmill can be transported in an appropriately equipped pickup truck:

1. Adjust the cutting head up just far enough so it will clear the sides of your truck bed when loaded. Do not adjust the cutting head so high that the sawmill will tip easily while being loaded.
2. Move the cutting head to one end of the bed frame. Engage the travel lock pin to prevent the cutting head from moving. Pull the pin and rotate and release so the roll pin seats in the locking position notch.

See Figure 3-19.

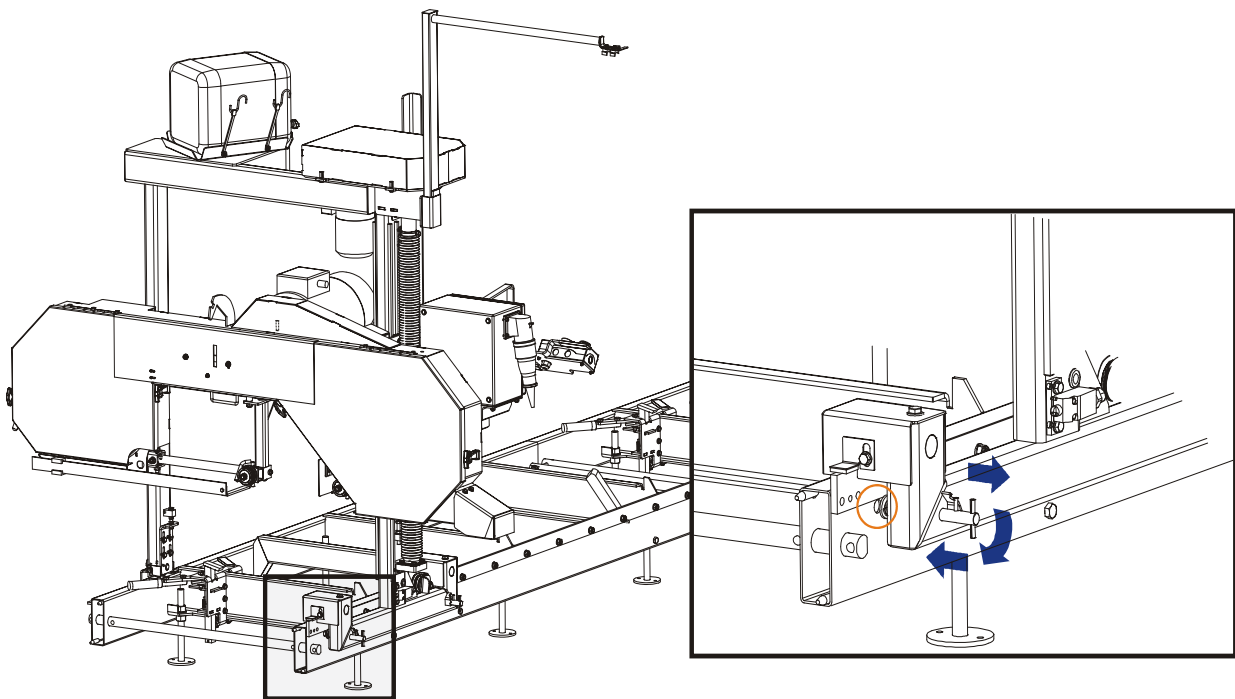

FIG. 3-19

3. Remove the leg assemblies or adjust them above the bottom of the bed frames.
4. Position the bed of the truck at the end of the frame opposite the cutting head.
5. While two people lift the end of the frame without the cutting head, back the truck under the sawmill until the the end of the frame is resting firmly on the bed of the truck.

3

Setup & Operation

Transporting the Sawmill

6. With a person positioned on either side of the cutting head, disengage the travel lock pin. Push the cutting head up the bed frame and engage the travel lock pin in the end of the frame in the truck bed.
7. Use two people to lift the end of the mill still on the ground and slide the sawmill into the truck bed.



WARNING! Keep all persons out of the path of the cutting head while loading and unloading the sawmill. Failure to do so may result in serious injury or death.

8. Secure the sawmill to the truck bed to prevent the sawmill from shifting while it is being transported.

Wood-Mizer LT15 Short Interval Maintenance Schedule

(Check engine and option manuals for additional maintenance procedures)

PROCEDURE	MANUAL REFERENCE
EVERY BLADE CHANGE	
Check Blade Guide Roller Performance	SEE SECTION 4.2
Remove Excess Sawdust From Blade Wheel Housings And Sawdust Chute	SEE SECTION 4.2
EVERY 8 HOURS	
Clean And Lubricate Track	SEE SECTION 4.3
Remove Sawdust From Upper Cam Housings	SEE SECTION 4.3

WOOD-MIZER LT15 MAINTENANCE LOG

(Check Engine And Option Manuals For Additional Maintenance Procedures)

PROCEDURE	MANUAL REFERENCE	TOTAL HOURS OF OPERATION									
		<i>FILL IN THE DATE AND THE MACHINE HOURS AS YOU PERFORM EACH PROCEDURE. A SHADED BOX INDICATES MAINTENANCE IS NOT NEEDED AT THIS TIME.</i>									
		50 HRS	100 HRS	150 HRS	200 HRS	250 HRS	300 HRS	350 HRS	400 HRS	450 HRS	500 HRS
Clean & lube mast	See Section 4.4										
Rotate drive/idle blade wheel belts/Check for wear	See Section 4.6										
Lubricate blade tensioner screw	See Section 4.5										

WOOD-MIZER LT15 MAINTENANCE LOG

(Check Engine And Option Manuals For Additional Maintenance Procedures)

PROCEDURE	MANUAL REFERENCE	TOTAL HOURS OF OPERATION									
		<i>FILL IN THE DATE AND THE MACHINE HOURS AS YOU PERFORM EACH PROCEDURE. A SHADED BOX INDICATES MAINTENANCE IS NOT NEEDED AT THIS TIME.</i>									
		550 HRS	600 HRS	650 HRS	700 HRS	750 HRS	800 HRS	850 HRS	900 HRS	950 HRS	1000 HRS
Clean & lube mast	See Section 4.4										
Rotate drive/idle blade wheel belts/Check for wear	See Section 4.6										
Lubricate blade tensioner screw	See Section 4.5										

WOOD-MIZER LT15 MAINTENANCE LOG

(Check Engine And Option Manuals For Additional Maintenance Procedures)

PROCEDURE	MANUAL REFERENCE	TOTAL HOURS OF OPERATION									
		<i>FILL IN THE DATE AND THE MACHINE HOURS AS YOU PERFORM EACH PROCEDURE. A SHADED BOX INDICATES MAINTENANCE IS NOT NEEDED AT THIS TIME.</i>									
		1050 HRS	1100 HRS	1150 HRS	1200 HRS	1250 HRS	1300 HRS	1350 HRS	1400 HRS	1450 HRS	1500 HRS
Clean & lube mast	See Section 4.4										
Rotate drive/idle blade wheel belts/Check for wear	See Section 4.6										
Lubricate blade tensioner screw	See Section 4.5										

WOOD-MIZER LT15 MAINTENANCE LOG

(Check Engine And Option Manuals For Additional Maintenance Procedures)

PROCEDURE	MANUAL REFERENCE	TOTAL HOURS OF OPERATION									
		<i>FILL IN THE DATE AND THE MACHINE HOURS AS YOU PERFORM EACH PROCEDURE. A SHADED BOX INDICATES MAINTENANCE IS NOT NEEDED AT THIS TIME.</i>									
		1550 HRS	1600 HRS	1650 HRS	1700 HRS	1750 HRS	1800 HRS	1850 HRS	1900 HRS	1950 HRS	2000 HRS
Clean & lube mast	See Section 4.4										
Rotate drive/idle blade wheel belts/Check for wear	See Section 4.6										
Lubricate blade tensioner screw	See Section 4.5										

SECTION 4 MAINTENANCE

This section lists the maintenance procedures that need to be performed.

The Short Interval Maintenance Schedule lists procedures that need to be performed every 4, 8 or 25 hours. The Maintenance Log lists procedures that need to be performed every 50, 100, 200, or 1000 hours. Keep track of machine maintenance by filling in the machine hours and the date you perform each procedure.



This symbol identifies the interval (hours of operation) at which each maintenance procedure should be performed.

Be sure to refer to option and motor/engine manuals for other maintenance procedures.

4.1 Wear Life

See Table 4-1. This chart lists estimated life expectancy of common replacement parts if proper maintenance and operation procedures are followed. Due to the many variables which exist during sawmill operation, actual part life may vary significantly. This information is provided so that you may plan ahead in ordering replacement parts.

Part Description	Estimated Life
B57 Blade Wheel Belts	500 hours
Blade Guide Rollers	1000 hours
Drive Belt	1250 hours

TABLE 4-1

4.2 Sawdust Removal

Remove the excess sawdust from the blade wheel housing and sawdust chute every blade change.

4.3 Carriage Track & Rollers

See Figure 4-1.

1. Clean the track bar to remove any sawdust and sap buildup every eight hours of operation.
2. Remove sawdust from the track roller housings. Remove the track roller housing covers and brush any sawdust buildup from the housings.

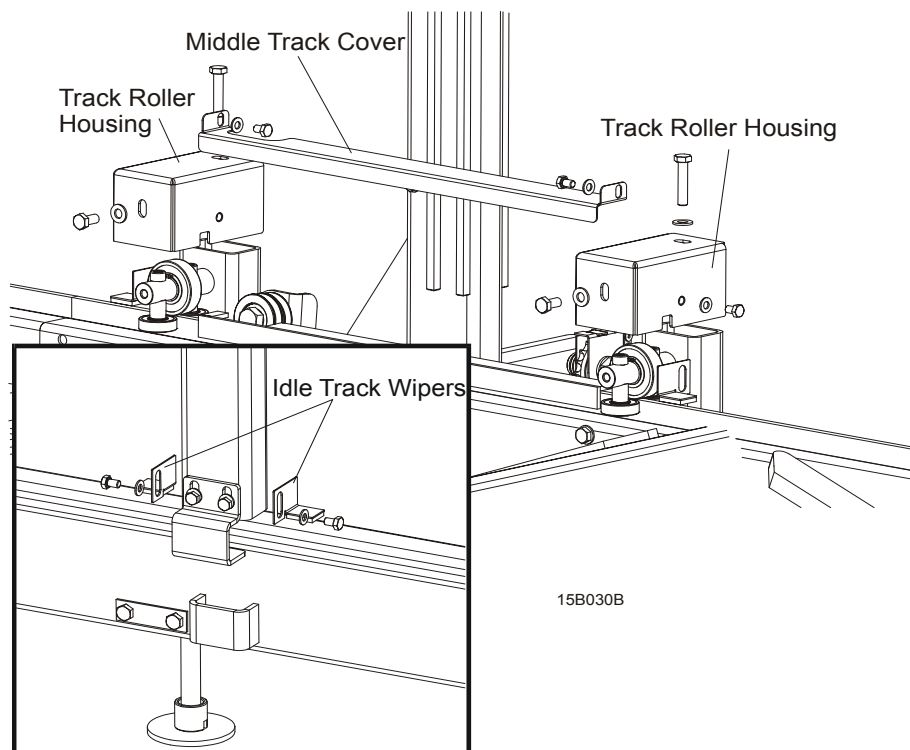

FIG. 4-1

4.4 Vertical Mast Rails

- 50 Clean and lubricate the vertical mast rails every 50 hours of operation. Clean with solvent and remove any rust with a light-grade sand paper. Lubricate the mast with motor oil or automatic transmission fluid (e.g. Dextron II or Dextron III).



CAUTION! Never use grease on the mast rails as it will collect sawdust.

4.5 Miscellaneous Lubrication

1. Lubricate the tensioner screw with a rolling bearing grease (e.g. LT4S or Shell Extreme Pressure Grease) as needed.

See Figure 4-2.

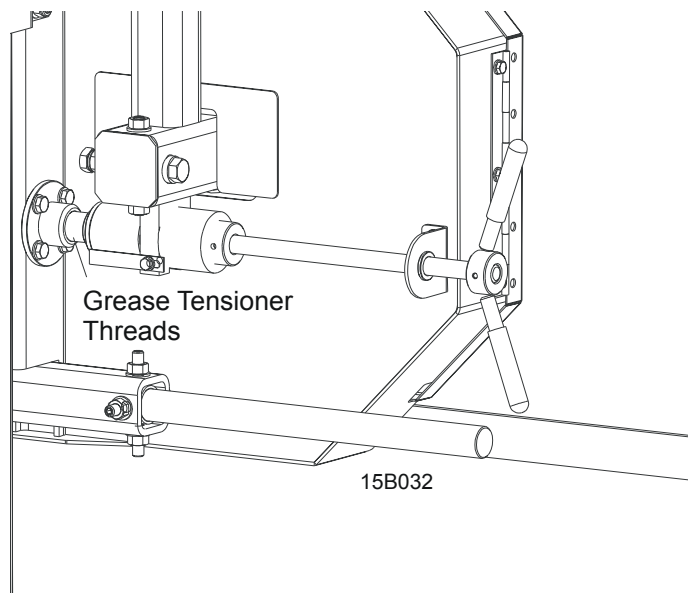



FIG. 4-2

4.6 Blade Wheel Belts

1. Rotate the blade wheel belts and check them for wear. Rotating the belts every 50 hours will give you longer belt life. Replace belts as necessary. Use only B57 belts manufactured by Goodyear or Browning.

2. Periodically check all belts for wear. Replace any damaged or worn belts as needed.

4.7 Up/Down System

1. Remove any sawdust buildup from the up/down screw bellows, the up/down screw nut, the upper and lower limit switches and the lower bearing housing.

See Figure 4-3.

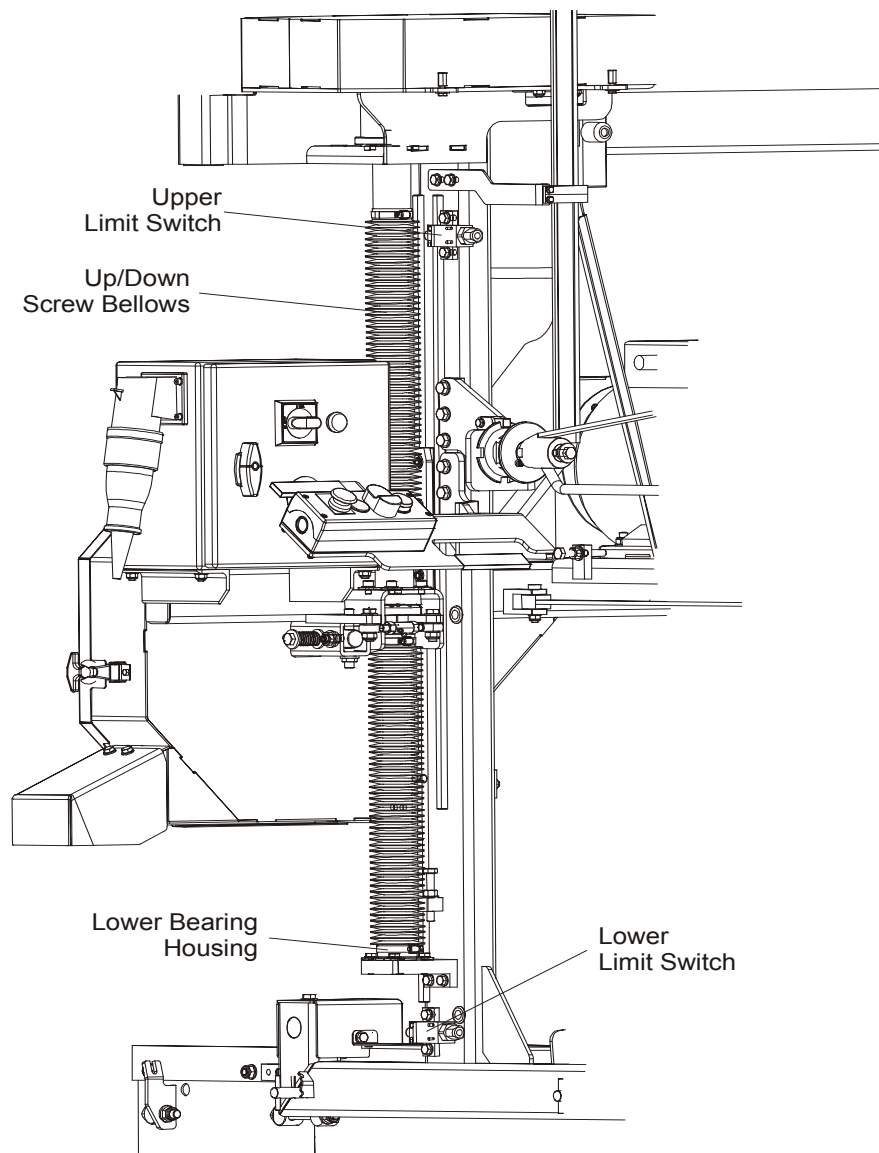

FIG. 4-3

2. Lubricate the up/down acme screw with a rolling bearing lubricant (e.g. LT4S or Shell Extreme Pressure Grease) every six months. Apply the lubricant to the grease fitting in

4

Maintenance Up/Down System

the nut housing. Lubrication may be required sooner if environmental conditions require it. If the lubricant appears to have dispersed or is dry or crusted, reduce the maintenance interval.

The up/down screw bellows should completely cover the screw. If either of the bellows is damaged, replace it immediately. Before installing the new bellows, clean the up/down screw and nut thoroughly with extraction naphtha. The acme screw nut (Part No. 094243) should be replaced if the end play is larger than 1.25 mm.

3. Check the up/down belt tension after the first 20 hours of operation and every 100 hours thereafter.

See Figure 4-4. Unbolt the up/down top guard. Loosen the motor mounting bolts. Use the adjustment bolt shown below to adjust the belt tension. Tighten the motor mounting bolts. Replace the top guard.

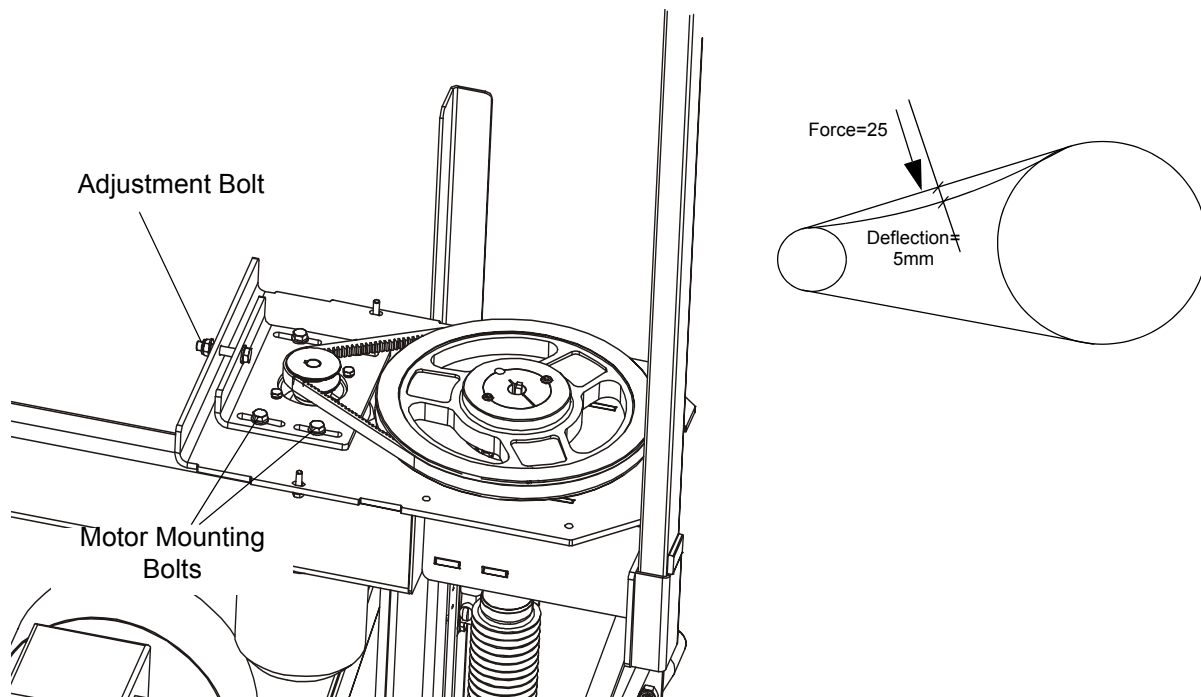
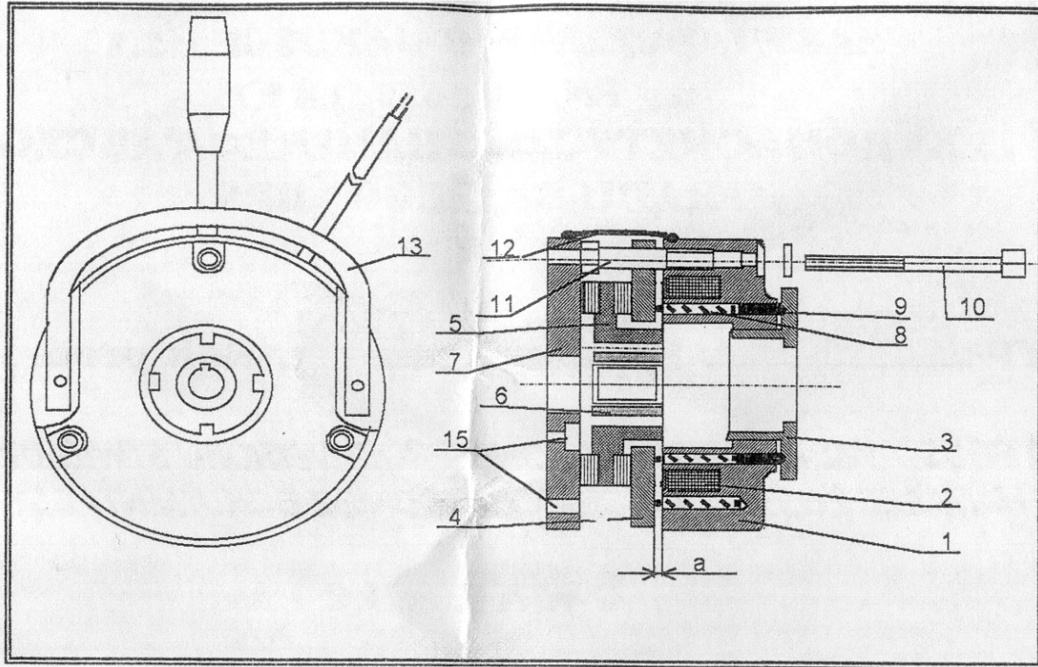

FIG. 4-4

4. Every 200 hours of operation check and adjust if necessary the up/down motor brake air

gap.



RYS. 4-5

1. Electromagnet body
2. Coil
3. Nut
4. Armature
5. Brake disk
6. Gear wheel
7. Mounting disk
8. Spring
9. Thrust pin
10. Mounting bolt
11. Adjusting bolt
12. Brake casing
13. Manual release lever
14. Locking element
15. Mounting holes

ADJUSTMENT OF AIR GAP

The air gap „a" grows gradually larger in consequence of wear of brake disc lining (5). The nominal value of the air gap "a nom" may be restored by screwing in the adjusting bolts (11). Prior to adjustment, slacken mounting bolts (10) and then set the nominal value of air gap using the feeler gauge inserted between armature (4) and body and screwing in the adjusting bolts (11). Tighten the mounting (10) and secure the position by screwing out the adjusting bolts as far as they go.

Table 4:

TYPE	HPS08
a nom.	0,2 ± 0,05
a max.	0,5

BRAKE MAINTENANCE

The brakes do not require special maintenance procedures, however during regular intervals of time depending on intensity of brake operation, perform inspections and regulation of air gap "a". When the brake disk reaches maximum wear, replace it with a new one. While replacing the brake disk, take care that the friction surface of the disk, armature and elements cooperating with the friction linings are free from grease and oil. Remove all dirt accumulated from the brake interior. If in spite of correct mounting and proper regulation, the brake does not operate, failure is due to: electromagnet - burnt coil, damaged supply cable, rectifier system (installed in the motor terminal box or control cabinet of the machine), electrical connections - check for correctness and quality of connections, damaged elements - replace them with new ones.

4.8 Miscellaneous Maintenance

1. Check the drive belt tension after the first 20 hours, and every 50 hours thereafter. See Section 6.13 for drive belt adjustment instructions.
2. Check the mill alignment every setup. See Section 6, Alignment.
3. Make sure all safety warning decals are readable. Remove sawdust and dirt. Replace any damaged or unreadable decals immediately. Order decals from your Customer Service Representative.

SECTION 5 TROUBLESHOOTING GUIDE

5.1 Sawing Problems

PROBLEM	CAUSE	SOLUTION
Blades Dull Quickly	Dirty logs	Clean or debark logs, especially on entry side of the cut
	When grinding teeth, heating too much and causing teeth to soften	Grind just enough metal to restore sharpness to the teeth. Use water/coolant while sharpening blade.
	Poor sharpening techniques	Make sure the tip is being sharpened completely (See Sharpener Manual).
Blades Break Prematurely	Rubber belts on blade wheels worn to a point that blade contacts metal pulley - look for shiny spots on edge of wheels.	Change blade wheel belts (B-57).
	Poor sharpening techniques	See Sharpener Manual.
	Tension too tight	Tension blade to recommended specifications.
Blade Does Not Track Right on Wheels	Cant adjustment is incorrect	Readjust. (See Section 3.4.)
	Flat/worn belts	Replace B-57 belts.
Blade Guide Rollers Do Not Spin While Cutting	Frozen bearings	Replace bearings.
	Worn bearings	Replace bearings.
Drive Belts Wear Prematurely or Jump	Engine/motor and drive pulleys out of alignment	Align pulleys.

5 Troubleshooting Guide

Sawing Problems

PROBLEM	CAUSE	SOLUTION
Boards Thick Or Thin On Ends Or Middle Of Board	Stress in log which causes log to not lay flat on the bed	After log has been squared, take equal cuts off opposing sides. Take a board off the top. Turn the log 180 degrees. Take a board off. Repeat, keeping the heart in the middle of the cant, and making it your last cut.
	Set in teeth	Resharpen and reset blade.
	Bed rails misaligned	Realign sawmill.
Height Adjustment Jumps or Stutters When Moving Up or Down	Mast needs lubrication	Lubricate mast track surface.
	Mast slide pads are not adjusted properly (the entire surface of the pad should touch the mast)	Adjust pads.
Lumber Is Not Square	Vertical side supports not square to bed	Adjust side supports.
	Blade not parallel to bed rails	Adjust bed rails parallel to blade.
	Sawdust or bark between cant and bed rails	Remove particles.
Sawdust Builds Up On Track	Tooth set problems	Resharpen and reset blade.
	Excessive lubrication	Do not lubricate track with grease.
	Track is sticky	Clean track with solvent and apply silicone spray.
Wavy Cuts	Excessive feed	Slow down feed rate.
	Improperly sharpened blade (This will be the problem 99% of the time!)	Resharpen blade. (See Sharpener Manual - read entire manual!)
	Blade guides improperly adjusted	Adjust blade guides.
	Sap buildup on blade	Remove sap. Use larger amount of water flow to the blade during cutting.
	Tooth set problem	Resharpen and reset blade.

SECTION 6 ALIGNMENT

6.1 Pre-Alignment Procedures

Periodically check the sawmill alignment and adjust if necessary. This chapter explains how to align the entire sawmill. Care should be taken in performing these steps. Sawmill alignment determines the accuracy and squareness of your cuts.

The sawmill alignment steps are:

1. Prepare the sawmill for alignment
2. Adjust the blade parallel to the bed rails
3. Adjust the blade guide arm parallel to the saw head brace
4. Align blade guides to the blade
5. Adjust side supports square to the bed
6. Final Adjustments.

To insure accurate alignment, the sawmill frame must be level and a blade properly installed.

[See SECTION 3 Setup & Operation](#) for setup information.



Alignment

Preparing The Sawmill For Alignment

6.2 Preparing The Sawmill For Alignment

Before performing the following alignment procedures, setup the mill on firm, level ground. String the bed and adjust the legs so the frame is level as described in [Section 3.1](#).

6.3 Blade Installation and Alignment

Install a blade and apply the appropriate tension as shown in [Section 3.3](#).

1. Close the blade housing cover and make sure all persons are clear of the open side of the saw head.
2. Start the motor for a moment.



WARNING! Do not spin the blade wheels by hand. Spinning the blade wheels by hand may result in serious injury.

3. Turn off the motor, open the blade housing cover, remove the key from the key switch (or turn off the power supply using the switch on the electric box) and check the position of the blade on the blade wheels.

Check the vertical alignment of the idle-side blade wheel. The gullet of the blade should ride the same distance from the front edge of the wheel at the top and bottom of the wheel. If it does not, loosen and tighten the appropriate adjustment screws on the wheel shaft.

See Figure 6-1. The blade wheels should be adjusted so that the gullet of 1 1/4" blades ride 1/8" (3 mm) out from the front edge of the wheels ($\pm 1/26$ [1 mm]). The gullet of 1 1/2" blades should ride 3/16" (4.5 mm) from the front edge of the wheels ($\pm 1/26$ [1 mm]). Do not let the teeth ride on the wheels.

6 Alignment

Blade Installation and Alignment

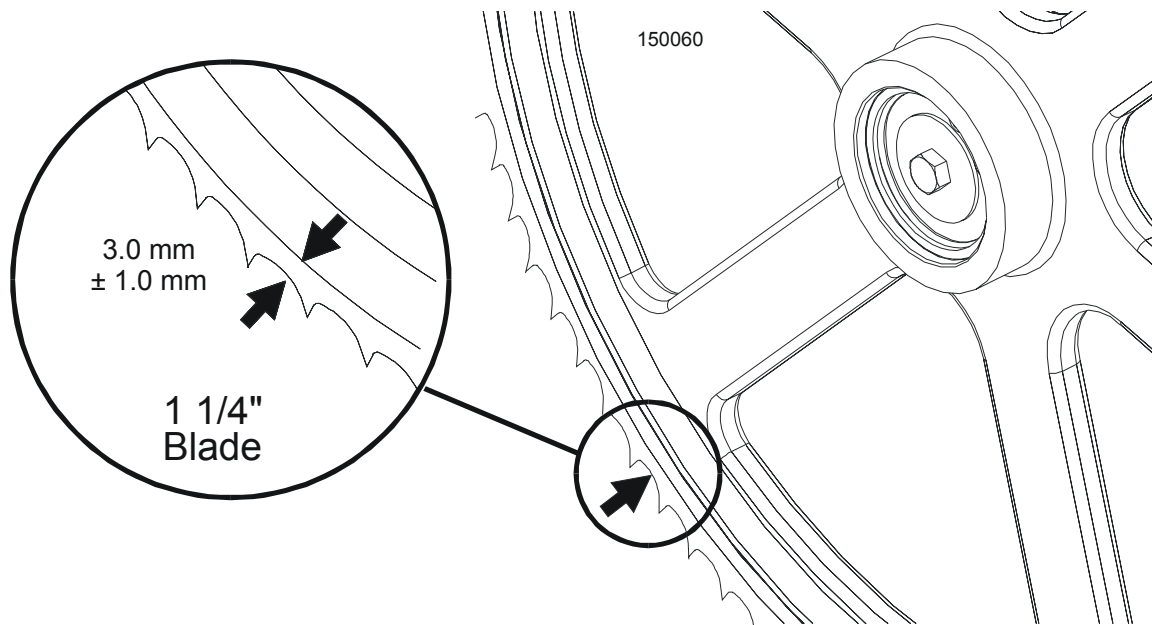

FIG. 6-1

To adjust where the blade travels on the idle-side and drive-side blade wheel, [See Section 6.4.](#)

6.4 Blade Wheel Alignment

The blade wheels should be adjusted so they are level in the vertical and horizontal planes. If the blade wheels are tilted up or down, the blade will want to travel in the tilted direction. If the blade wheels are tilted horizontally, the blade will not track properly on the wheels.

1. Use the blade guide alignment tool to check the vertical alignment of each blade wheel. Attach the tool to the blade near the inner blade guide mount. Be sure the tool does not rest on a tooth or burr, and is lying flat against the bottom of the blade.

See Figure 6-2.

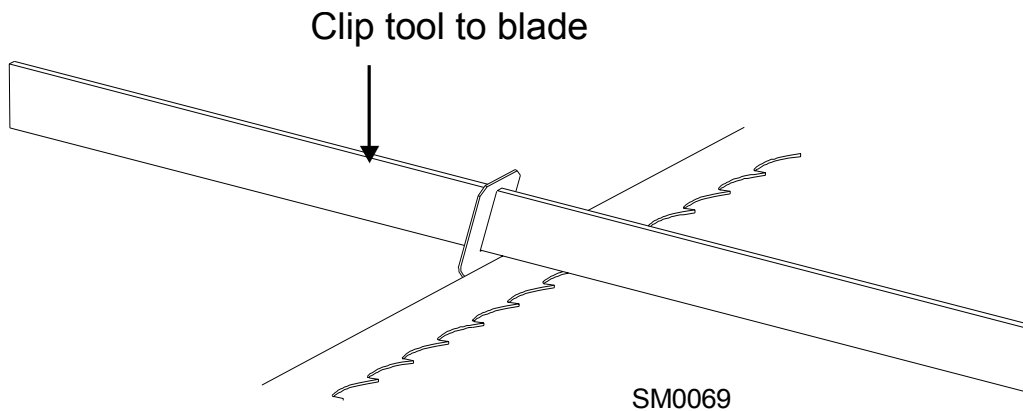

FIG. 6-2

2. Move the saw carriage so the front end of the tool is positioned over the first bed rail. Measure from the bottom of the tool to the top surface of the bed rail.
3. Move the saw carriage so the rear of the tool is positioned over the bed rail. Again, measure from the bottom of the tool to the bed rail.
4. If the two measurements differ by more than 1/16" (1.5 mm), adjust the vertical tilt of the drive-side blade wheel.

6

Alignment

Blade Wheel Alignment

See Figure 6-3. Use the vertical adjustment screws to adjust the drive-side blade wheel. To tilt the wheel, loosen the top adjustment screw one quarter turn. Loosen the jam nut on the bottom adjustment screw and tighten the screw. Tighten the top and bottom jam nuts.

To tilt the wheel, loosen the bottom adjustment screw one quarter turn. Loosen the jam nut on the top adjustment screw and tighten the screw. Tighten the top and bottom jam nuts.

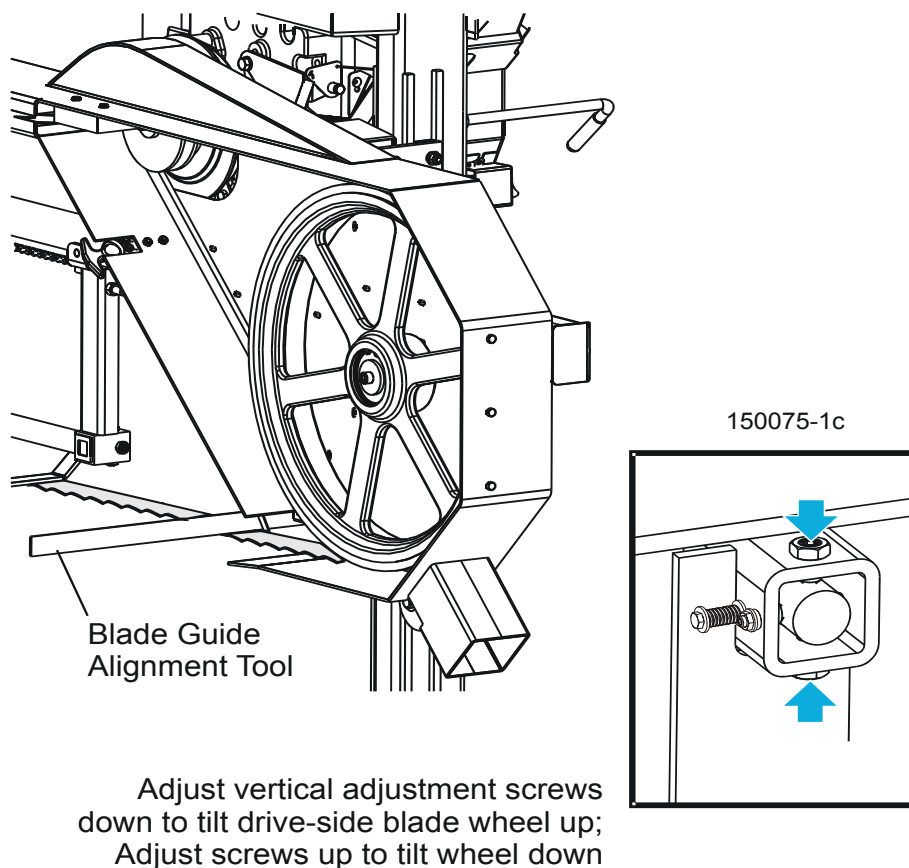

FIG. 6-3

5. Recheck the vertical tilt of the drive-side blade wheel with the blade guide alignment tool. Readjust the blade wheel as necessary until the front and rear of the tool are the same distance from the bed rail (within 1/16" [1.5 mm]).
6. Remove the tool from the blade and reattach it near the outer blade guide assembly.
7. Measure from the tool to the bed rail at both ends of the tool. If the measurements at the front and rear ends of the tool differ by more than 1/16" (1.5 mm), adjust the vertical tilt of

the idle-side blade wheel.

See Figure 6-4. Use the vertical adjustment screws to adjust the idle-side blade wheel. To tilt the wheel up, loosen the bottom adjustment screw one quarter turn. Loosen the jam nut on the top adjustment screw and tighten the screw. Tighten the top and bottom jam nuts.

To tilt the wheel down, loosen the top adjustment screw one quarter turn. Loosen the jam nut on the bottom adjustment screw and tighten the screw. Tighten the top and bottom jam nuts.

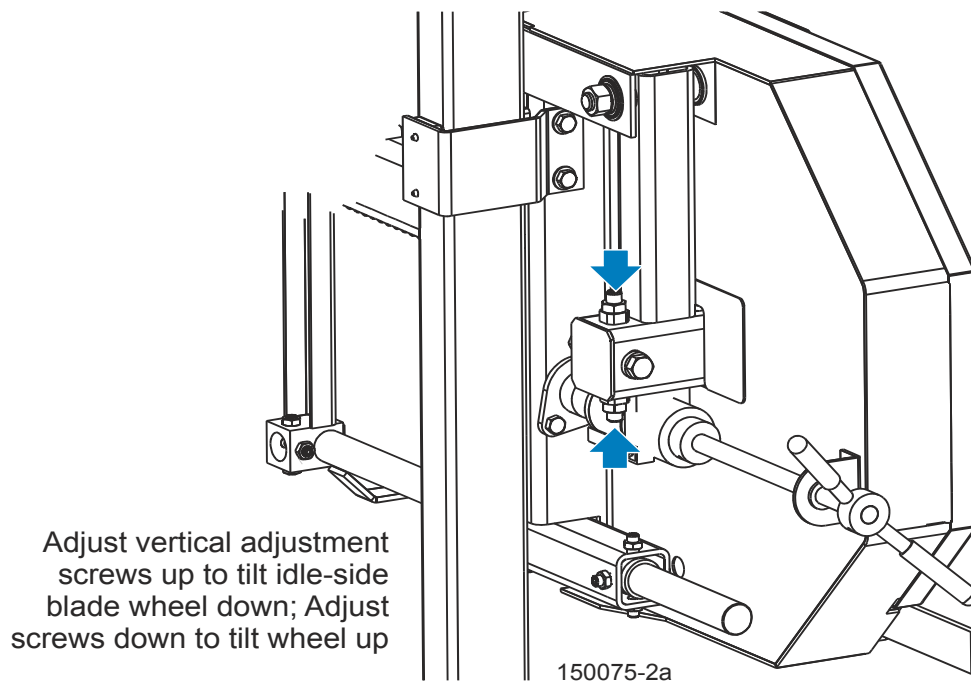

FIG. 6-4

8. Recheck the vertical tilt of the idle-side blade wheel with the blade guide alignment tool. Readjust the blade wheel as necessary until the front and rear of the tool are the same distance from the bed rail (within 1/16" [1.5 mm]).

6

Alignment

Blade Wheel Alignment

9. Check the position of the blade on the idle-side blade wheel.

See Figure 6-5. The horizontal tilt of the blade wheel should be adjusted so that the gullet of an 1-1/4" blade is 1/8" (3 mm) out from the front edge of the wheel ($\pm 1/32$ [0.75 mm]).

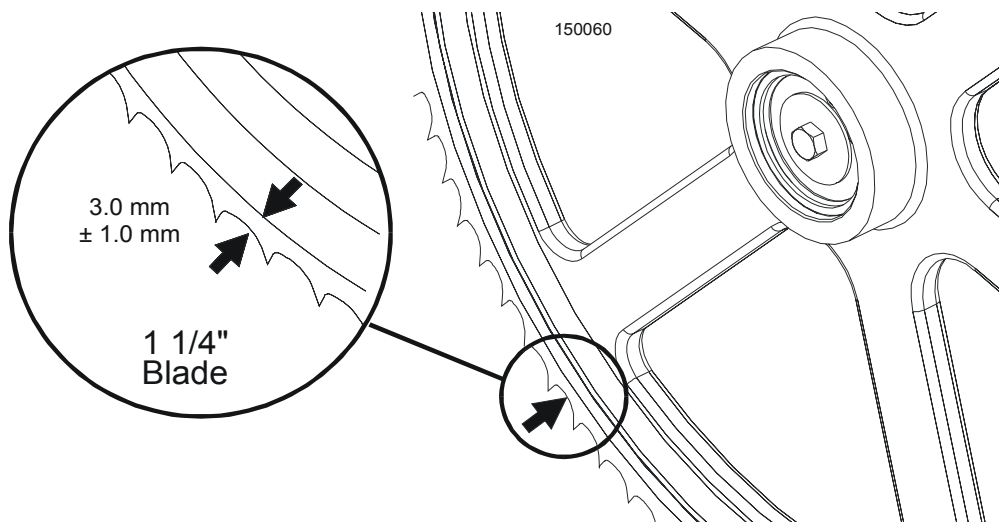

FIG. 6-5

See Figure 6-6. Use the cant control adjustment to adjust the idle-side blade wheel. If the blade is too far forward on the wheel, turn the cant control counterclockwise. If it is too far back on the wheel, turn the cant control clockwise.

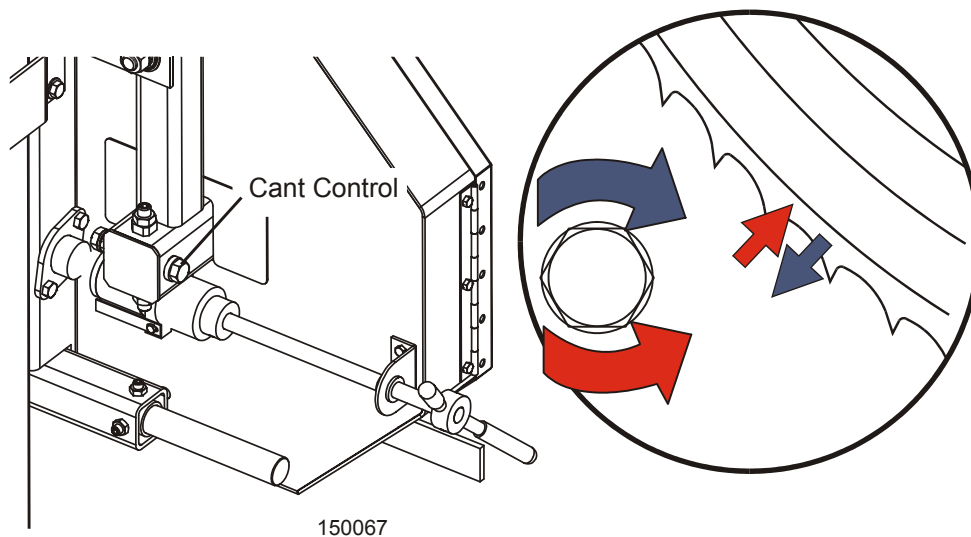

FIG. 6-6

10. Check the position of the blade on the drive-side blade wheel. The blade should be positioned on the wheel as described for the idle-side blade wheel. Adjust the drive-side blade

wheel if necessary.

See Figure 6-7. Use the horizontal adjustment screw to adjust the drive-side blade wheel. Loosen the jam nut on the adjustment screw. Loosen adjustment screw to move blade out on wheel. Tighten adjustment screw to move blade in on wheel. Tighten the jam nut.

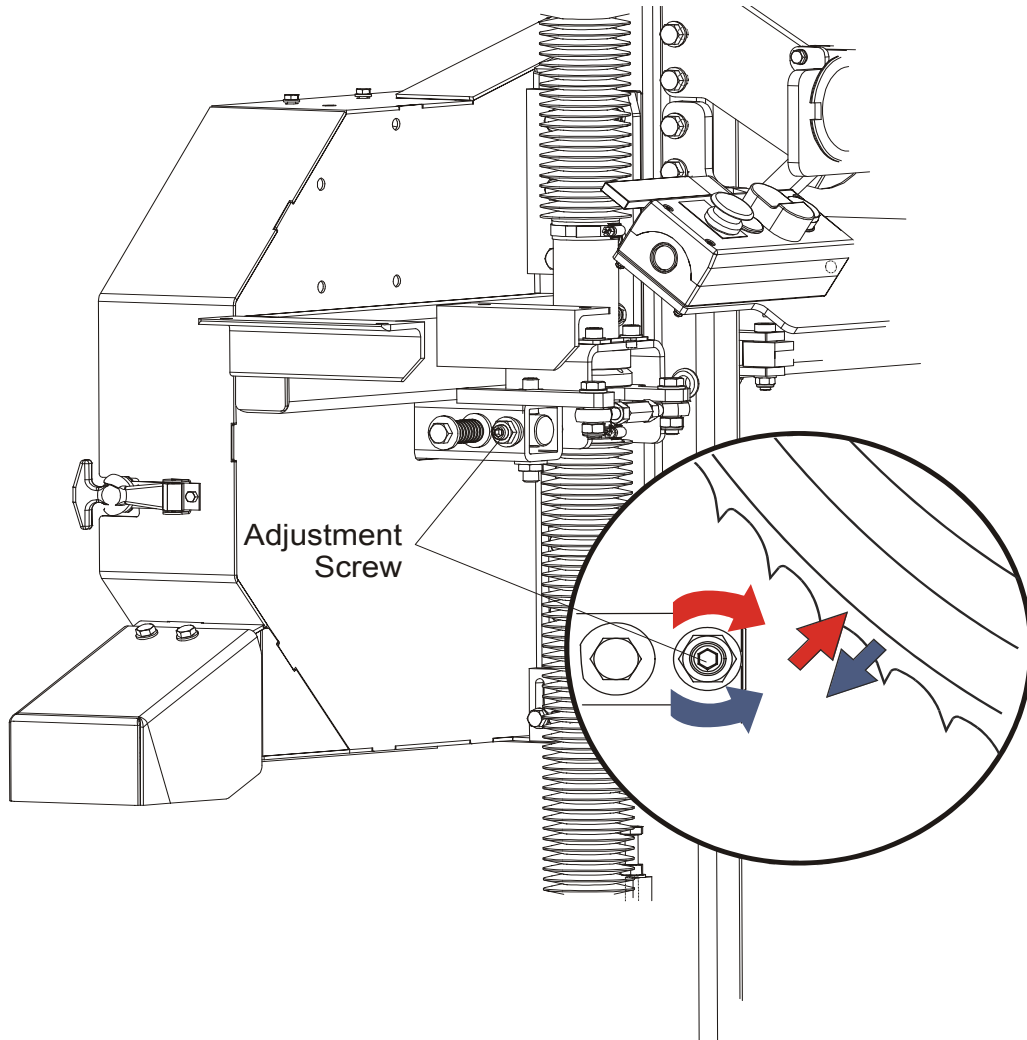

FIG. 6-7

6.5 Blade Guide Arm Alignment

Before aligning the blade guide arm, track the blade on the blade wheels as described in [Section 3.4](#). Move the cutting head so the blade is positioned over the first bed rail. Level the blade to the bed rail as shown in [Section 3.1](#). Adjust the blade guide rollers so they do not touch the blade.

Vertical Alignment

1. Adjust the blade guide arm all the way out away from the other blade guide (maximum distance between the guide rollers).

See Figure 6-8.

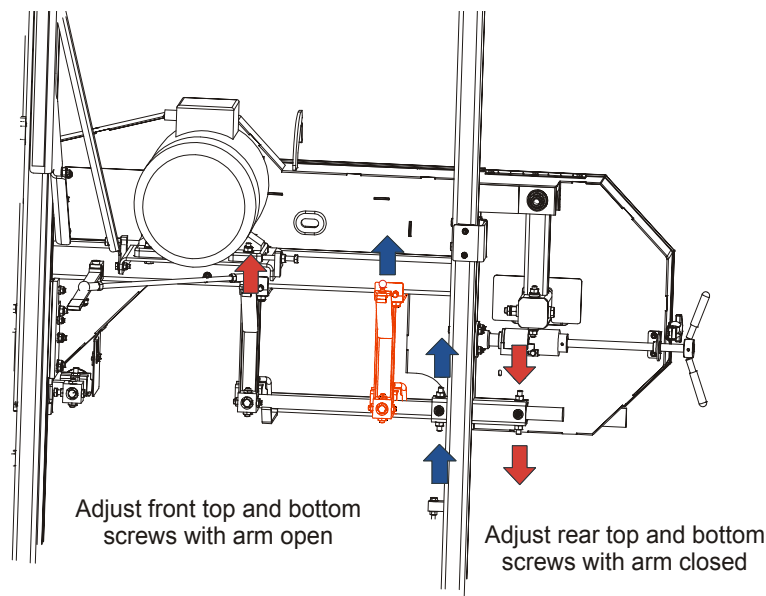

FIG. 6-8

2. Use the arm adjustment screws, marked with blue arrows in the figure above, to adjust the arm up until the slide pad touches the saw head brace tube. Tighten the jam nuts.
3. Adjust the blade guide arm in all the way toward the other blade guide (minimum distance between the guide rollers).
4. Use the arm adjustment screws, marked with red arrows in the figure above, to adjust the arm up until the slide pad touches the saw head brace tube. Tighten the jam nuts.

NOTE: When adjusting the blade guide arm screws, be careful not to damage their threads or deform the arm guide bushing. Operate the blade guide arm handle to ensure

the arm moves easily left and right when the handle is moved.

Horizontal Alignment

See Figure 6-9.

1. With the blade guide arm still all the way in toward the other blade guide, tighten all the side screws until they touch the arm. Back the screws off 1/4 turn and tighten the jam nuts.
2. Sight across the horizontal saw head brace to view the blade guide arm. Adjust all side screws on the blade guide arm housing so the arm is parallel to the saw head brace.
3. To move the blade guide end of the arm toward the front of the sawmill, loosen jam nuts on the front inside screw and the rear outside screw. Turn the screws counterclockwise one full turn and tighten the jam nuts. Loosen the jam nuts on the front outside screw and the rear inside screw. Turn the screws clockwise until they touch the arm, back off 1/4" turn, and tighten the jam nuts.
4. To move the blade guide end of the arm toward the rear of the sawmill, loosen jam nuts on the front outside screw and the rear inside screw. Turn the screws counterclockwise one full turn and tighten the jam nuts. Loosen the jam nuts on the front inside screw and the rear outside screw. Turn the screws clockwise until they touch the arm, back off 1/4" turn, and tighten the jam nuts.

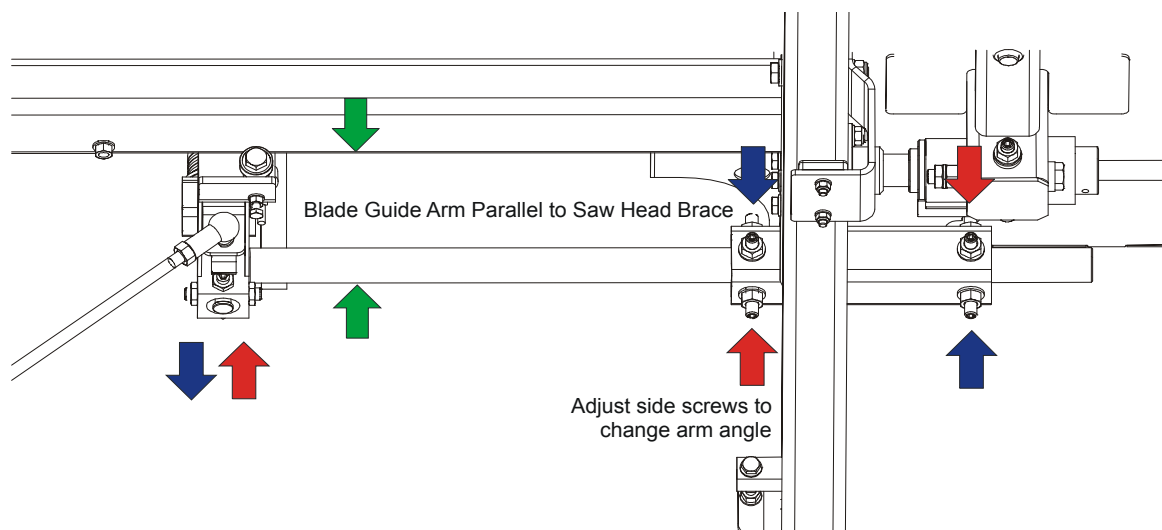

FIG. 6-9

6.6 Aligning The Blade Guides

Each Wood-Mizer sawmill has two blade guide assemblies that help the blade maintain a straight cut. The two blade guide assemblies are positioned on the saw head to guide the blade on each side of the material being cut.

One blade guide assembly is mounted in a stationary position on the drive side of the saw head. This assembly is referred to as the "inner" blade guide assembly.

The other blade guide assembly is mounted on the idle side of the saw head. It is referred to as the "outer" assembly and is adjustable for various widths of materials to be processed.

Blade guide alignment includes four steps:

- Blade Deflection
- Blade Guide Vertical Tilt
- Blade Guide Flange Spacing
- Blade Guide Horizontal Tilt

Perform the blade guide alignment after you have aligned the blade on the wheels and adjusted the blade and blade guide arm parallel to the bed rails. After blade guide alignment, check the scale indicator to make sure it is adjusted properly.

6.7 Blade Deflection

Perform the following steps to achieve proper blade deflection with the blade guides.

1. Raise the carriage until the blade is 15" (375 mm) above a bed rail. Measure the actual distance with a tape from the top of the rail to the bottom of the blade.

See Figure 6-10.

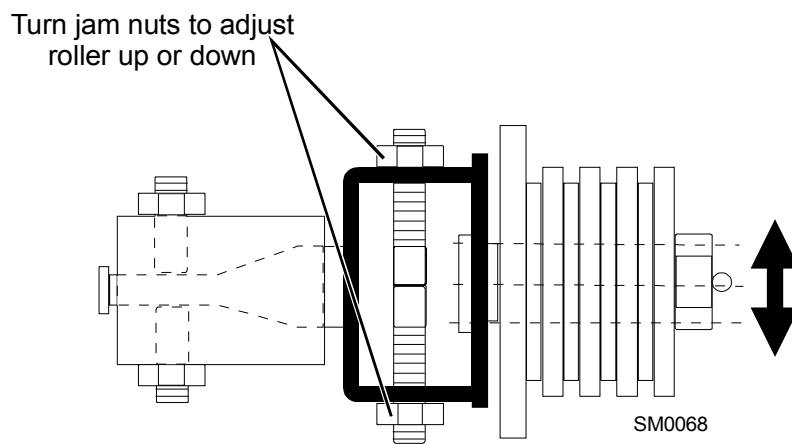

FIG. 6-10

2. Loosen the bottom jam nut and tighten the top jam nut until the blade guide deflects the blade down 1/4" (6 mm).
3. Repeat for the other blade guide.

NOTE: Be sure that the blade guard clears the blade on both guide assemblies. The guard on the outer guide assembly should be checked with the arm all the way in and all the way out.

6.8 Blade Guide Vertical Tilt Adjustment

Check that the blade guide does not tilt the blade up or down. A Blade Guide Alignment Tool (BGAT) is provided to help you measure the vertical tilt of the blade.

1. Open the adjustable blade guide arm 1/2" (15 mm) from full open.
2. Clamp the alignment tool on the blade. Position the tool close to a blade guide roller. Be sure the tool does not rest on a tooth or burr, and is lying flat on the blade.

See Figure 6-11.

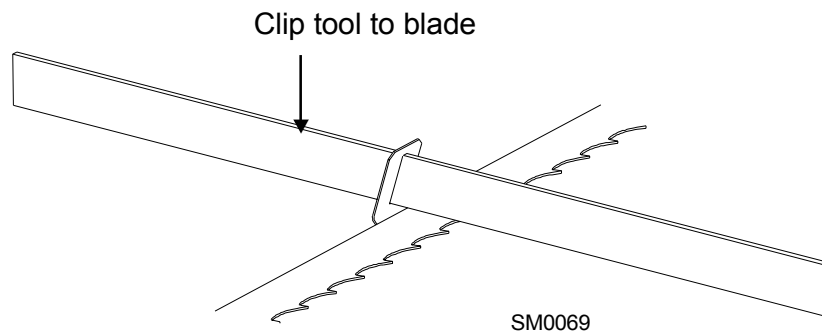

FIG. 6-11

3. Measure the distance from the bed rail to the bottom of the tool.
4. Move the carriage so that the front end of the tool is positioned above the bed rail.
5. Measure the distance from the bed rail to the bottom edge of the tool.
6. Loosen one set screw at the side of the blade guide assembly.
7. Use the set screws shown to tilt the blade guide until the measurement from the bed rail to the tool equals the first measurement taken at the center of the tool.

See Figure 6-12.

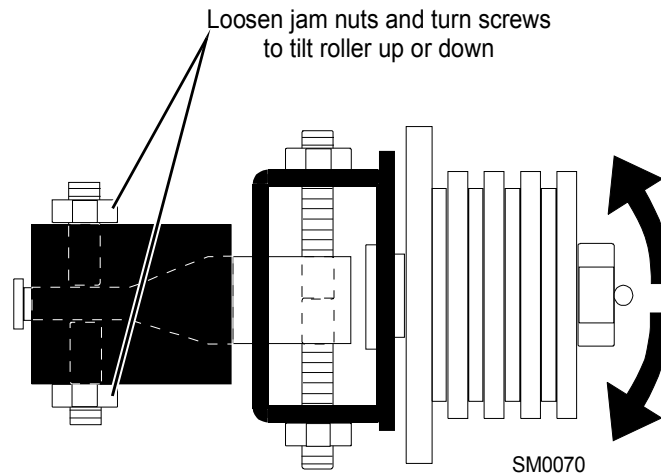

FIG. 6-12

8. Move the carriage forward so the back end of the tool is over the bed rail.
9. Use the set screws shown to adjust the blade guide tilt until the measurement from the bed rail to the tool equals the other two measurements taken.
10. Move the tool close to the other blade guide and repeat the previous steps.

NOTE: If major adjustments to blade guide tilt were made, remeasure the distance between the blade and the bed rails to ensure the correct 1/4" (6.5 mm) blade guide deflection. Adjust if necessary.

6.9 Blade Guide Spacing

HINT: When adjusting blade guide spacing, loosen the top set screw and one side set screw only. This will insure horizontal and vertical tilt adjustments are maintained when the set screws are retightened.

1. Adjust the inner blade guide so the blade guide flange is approximately 1/16" - 1/8" (1.5 - 3.0 mm) from the back of the blade.
2. Loosen one side and one top set screw shown. Tap the blade guide forward or backward until properly positioned.

See Figure 6-13.

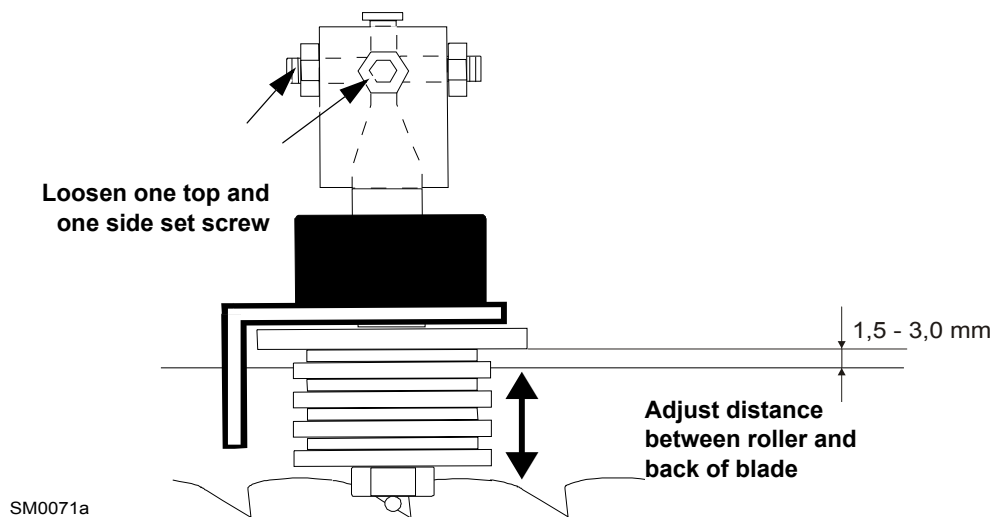

FIG. 6-13

3. Retighten the two set screws.
4. Adjust the outer blade guide in the same way so the blade guide flange is approximately 1/16" - 1/8" (1.5 - 3.0 mm) from the back of the blade.

NOTE: After adjusting the spacing of the rollers, start the blade motor for a moment. Then stop the blade and check the spacing again.

6.10 Horizontal Tilt Adjustment

1. Finally, both blade guides must be tilted horizontally. Adjust the blade guide arm half way in.

See Figure 6-14.

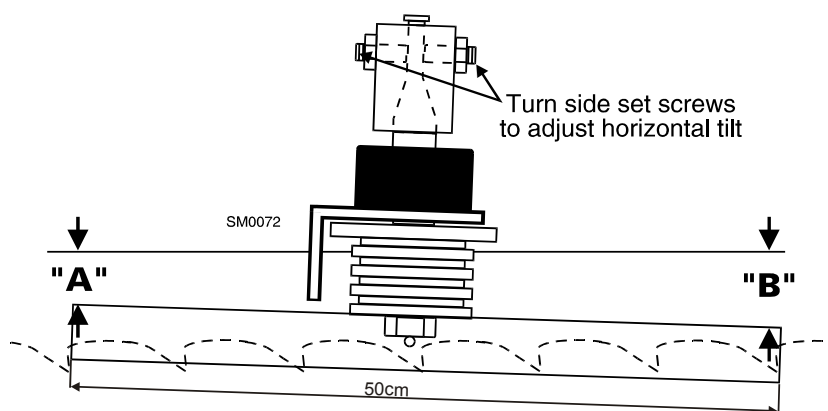

FIG. 6-14

2. Place Blade Guide Alignment Tool against the face of the outer blade guide roller.
3. Center the tool on the roller and measure between the back edge of the blade and the ruler at the end closest to the inner blade guide ("B").
4. Measure between the back edge of the blade and the other end of the ruler ("A").
5. The roller should be parallel to the blade ($A=B$) or tilted slightly to the left ($A=B-1/4"$ [6 mm]).
6. Use the side set screws to adjust the horizontal tilt of the roller.
7. Repeat Steps 3 - 7 for the inner blade guide roller.

NOTE: Once the blade guides have been adjusted, any cutting variances are most likely caused by the blade. See **Blade Handbook, Form #600**.

6.11 Side Supports

Logs and boards are clamped against the side supports when sawing. The side supports must be square to the bed to ensure square lumber.

1. Place a flat board across the bed rails.

See Figure 6-15.

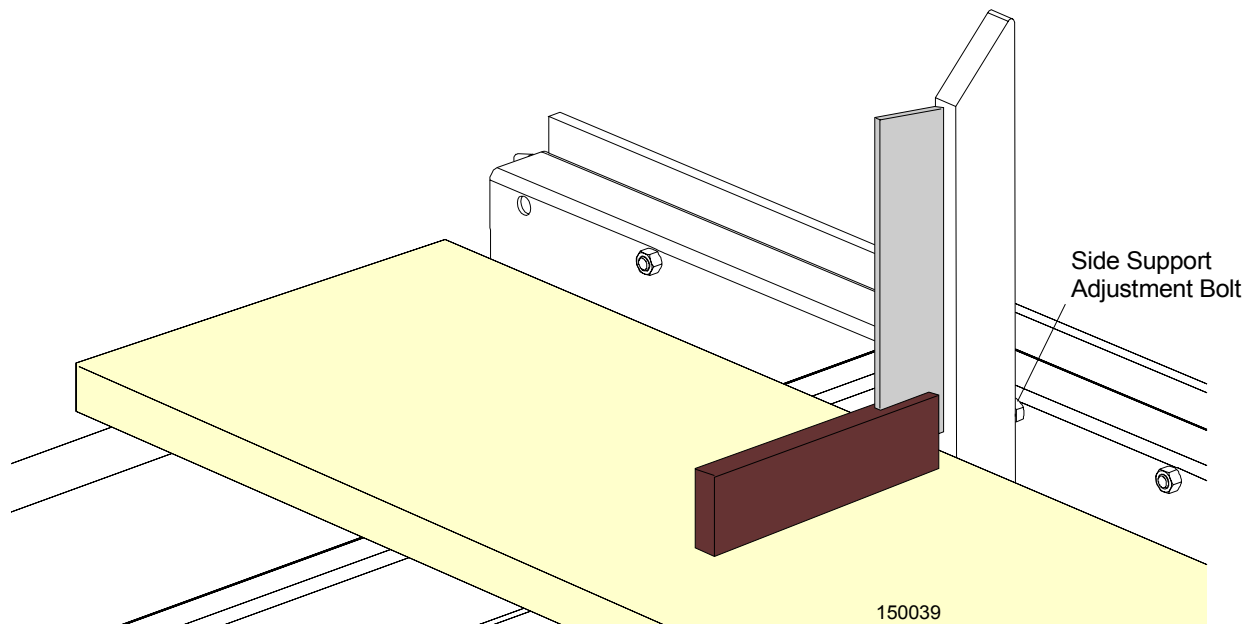

FIG. 6-15

2. Swing a side support up so that it is vertical.
3. Pull back at the top of the support to eliminate slack as if a log were being clamped against it.
4. Check the angle of each support with a square on the board.
5. The side support should be 90° to the bed rails. Turn the adjustment bolt counterclockwise to tilt the top of the side support forward.
6. Repeat for the remaining side supports.

6.12 Blade Height Scale Adjustment

After the entire sawmill has been aligned and all adjustments made, check that the blade height scale indicates the true distance from the blade to the bed rails.

1. The maximum distance between the scale and the scale indicator should be 5 mm. If it is different, loosen the indicator bracket mounting bolts and move the bracket in the horizontal plane until the correct distance is obtained. Retighten the bracket mounting bolts.
2. Move the saw head so the blade is positioned directly above one of the bed rails. Measure from the bottom edge on a down-set tooth of the blade to the top of the bed rail.

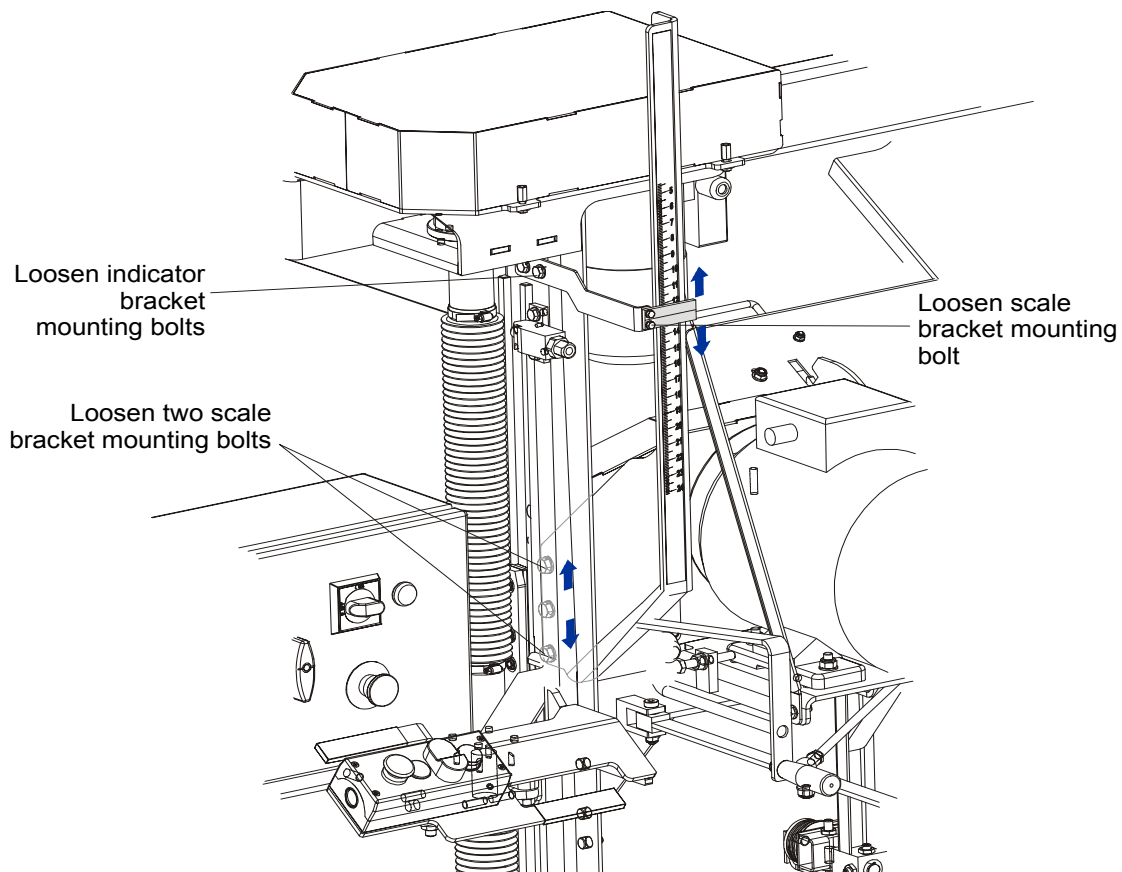

FIG. 6-15

3. Loosen the scale bracket mounting bolts and adjust the bracket until the indicator is aligned with the correct mark on the scale. Retighten the nuts on the bracket mounting bolts.

6

Alignment

Motor Drive Belt Adjustment

For example, if the measurement from blade to bed rail was 14 3/4" (375 mm), make sure the indicator reads 14 3/4" (375 mm) on the scale.

6.13 Motor Drive Belt Adjustment

See Figure 6-16. Loosen the motor mounting bolts. Using the adjustment bolts shown below, adjust the drive belt until it has 7/16" (11 mm) deflection with a 8 lbs (3.6 kG) deflection force - in the case of E11 motor or 7/16" (11 mm) deflection with a 16 lbs (7.2 kG) deflection force - in the case of E15 motor. Tighten the four motor mounting bolts.

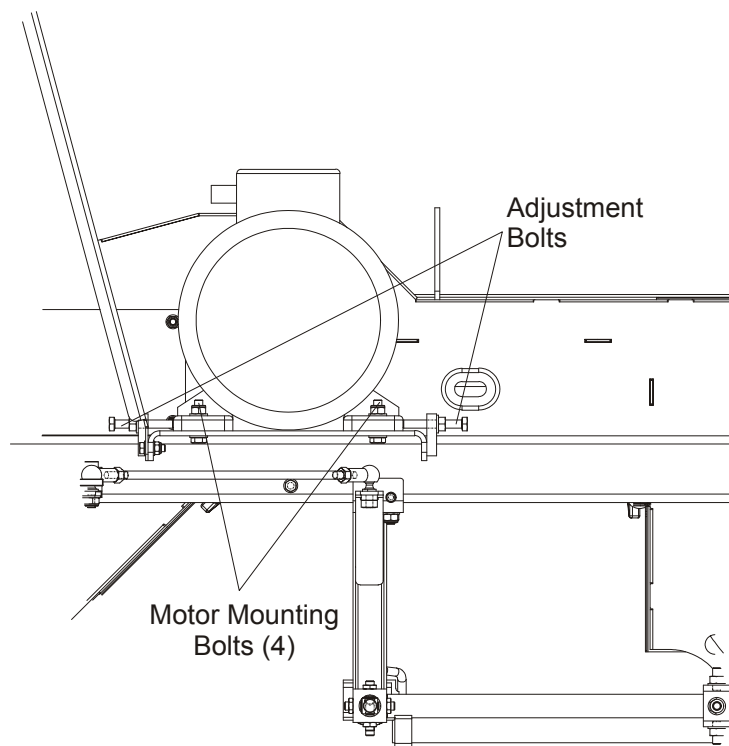

FIG. 6-16