

# **Wood-Mizer®**

## **Parts Manual**

---

**LT10S3 E7,5S**

**rev. A2.06**

---



**Safety is our #1 concern!** Read and understand all safety information and instructions before operating, setting up or maintaining this machine.

*December 2006*

*Form #795*

# Table of Contents

# Section-Page

<b>SECTION 1</b>	<b>GENERAL INFORMATION</b>	<b>1-1</b>
1.1	How To Use The Parts List .....	1-1
1.2	Sample Assembly .....	1-1
<b>SECTION 2</b>	<b>FRAME PARTS</b>	<b>2-1</b>
2.1	Side Supports Assembly .....	2-1
2.2	Sawmill Frame Fasteners .....	2-2
2.3	Frame Outriggers.....	2-3
2.4	Log Clamp Assembly .....	2-4
2.5	Log Wedge, Loading Ramps & Cant Hook (Optional).....	2-5
2.6	Bed Extension.....	2-6
2.7	Bed Section LT10.....	2-7
<b>SECTION 3</b>	<b>BLADE GUIDE ROLLERS &amp; ARM</b>	<b>3-1</b>
3.1	Blade Guide Assembly, Idle Side.....	3-1
3.2	Blade Guide Assembly, Drive Side.....	3-3
3.3	Blade Guide Roller Guard .....	3-5
3.4	Blade Guide Arm Assembly .....	3-6
<b>SECTION 4</b>	<b>BLADE WHEELS &amp; TENSIONER</b>	<b>4-1</b>
4.1	Blade Wheel Assembly, Drive Side .....	4-1
4.2	Blade Wheel Assembly, Idle Side .....	4-2
4.3	Blade Tensioner Assembly.....	4-3
4.4	Motor .....	4-4
4.5	Power Cord Bracket .....	4-5
<b>SECTION 5</b>	<b>SAW HEAD</b>	<b>5-1</b>
5.1	Blade Housing Cover .....	5-1
5.2	Water Lube Assembly .....	5-3
5.3	LT10 Saw Head Decals .....	5-4
5.4	Control Box .....	5-6
<b>SECTION 6</b>	<b>FEED SYSTEM</b>	<b>6-1</b>
6.1	Track Rail, Rollers & Travel Pins .....	6-1
6.2	Track Rail, Rollers & Travel Pins .....	6-3
<b>SECTION 7</b>	<b>UP/DOWN SYSTEM</b>	<b>7-1</b>
7.1	Up/Down Crank Assembly.....	7-1
7.2	Up/Down Drive Sprocket Assembly .....	7-2
7.3	Slide Pads and Blade Height Scale Indicator .....	7-4
7.4	Blade Height Scale (Optional).....	7-6

## SECTION 1 GENERAL INFORMATION

### 1.1 How To Use The Parts List

- Use the index above to locate the assembly that contains the part you need.
- Go to the appropriate section and locate the part in the illustration.
- Use the number pointing to the part to locate the correct part number and description in the table.
- Parts shown indented under another part are included with that part.
- Parts marked with a diamond (◆) are only available in the assembly listed above the part.

See the sample table below. Sample Part #A01111 includes part F02222-2 and subassembly A03333. Subassembly A03333 includes part S04444-4 and subassembly K05555. The diamond (◆) indicates that S04444-4 is not available except in subassembly A03333. Subassembly K05555 includes parts M06666 and F07777-77. The diamond (◆) indicates M06666 is not available except in subassembly K05555.

<b>1.2 Sample Assembly</b>				
REF	DESCRIPTION (◆ Indicates Parts Available In Assemblies Only)	PART #	QTY.	
	Sample Assembly, Complete (Includes All Indented Parts Below)	A01111	1	
1	Sample Part	F02222-22	1	
	Sample Subassembly (Includes All Indented Parts Below)	A03333	1	
2	Sample Part (◆ Indicates Part Is Only Available With A03333)	S04444-4	1	◆
	Sample Subassembly (Includes All Indented Parts Below)	K05555	1	
3	Sample Part (◆ Indicates Part Is Only Available With K05555)	M06666	2	◆
4	Sample Part	F07777-77	1	

#### **To Order Parts:**

- From Europe call our European Headquarters and Manufacturing Facility in Kolo, Poland at **+48-63-2626000**. From the continental U.S., call our toll-free Parts hotline at **1-800-525-8100**. Have your customer number, vehicle identification number, and part numbers ready when you call. From other international locations, contact the Wood-Mizer distributor in your area for parts.

#### **Office Hours:**

Country	Monday - Friday	Saturday	Sunday
Poland	7-15	Closed	Closed
US	8 a.m.- 5 p.m.	8 a.m. - 5 p. m.	Closed



**CAUTION!** It is strongly recommended that only original spare parts be used.

## SECTION 2 FRAME PARTS

### 2.1 Side Supports Assembly

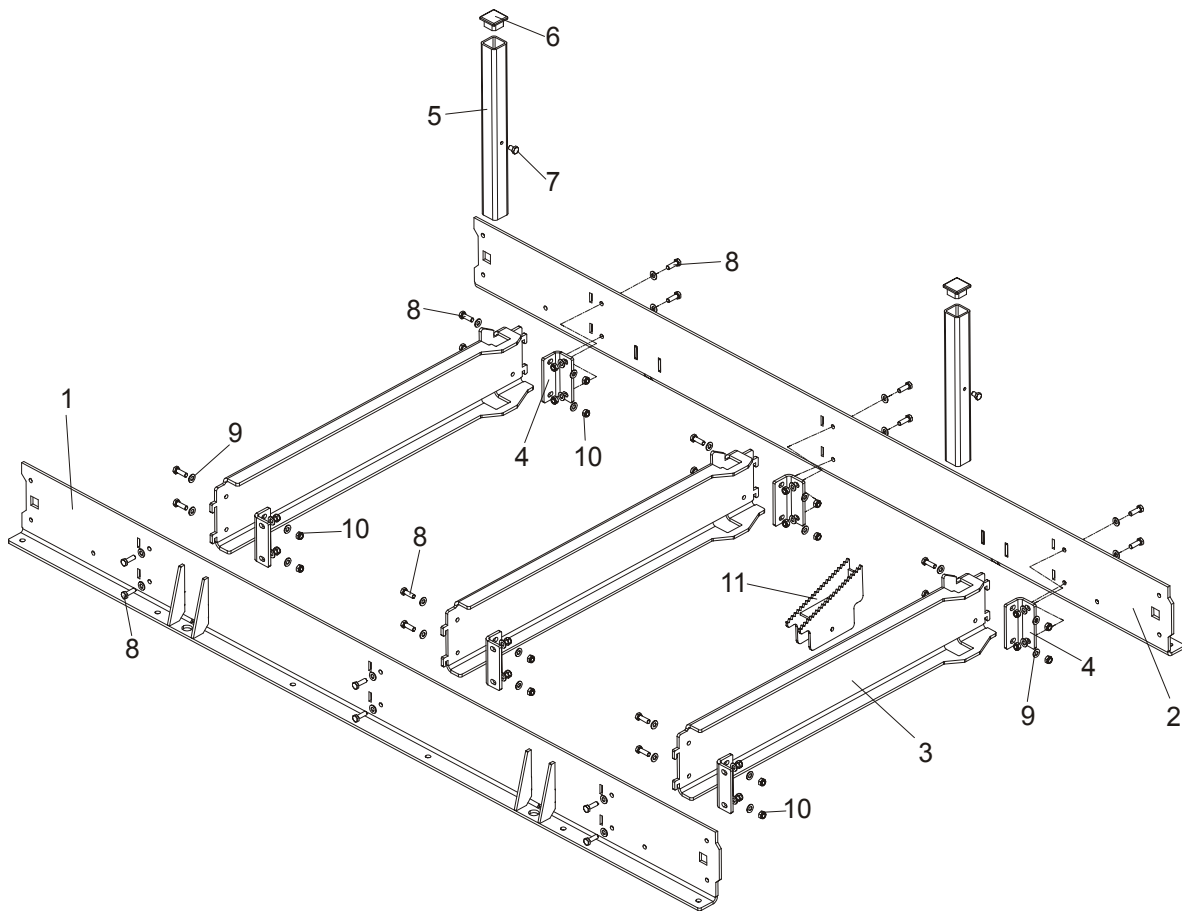

REF	DESCRIPTION (◆ Indicates Parts Available In Assemblies Only)	Part #	Qty.
1	PLATE, FRAME SUPPORTING RIGHT ZINC LT10	097465-1	1
2	PLATE, FRAME SUPPORTING LEFT ZINC LT10	097466-1	1
3	BED RAIL ASSEMBLY, LT10 ZINC	097181-1	1
4	SQUARE, FRAME MOUNT LT10 ZINC	097182-1	1
	<b>SIDE SUPPORT, SHORT LT10 COMPLETE</b>	097472	2
5	Side Support, Short LT10-Zinc	097471-1	1
6	Cap, Tube 40x40x(3-4)	097480	1
7	Screw, M8x12-8.8 Hex Head Full Thread Zinc	F81002-6	1
8	<b>SCREW, M8x25-8.8-B HEX HEAD FULL THREAD</b>	F81002-5	26
9	<b>WASHER, 8,4 FLAT ZINC</b>	F81054-1	52
10	<b>NUT, M8-8-B HEX NYLON ZINC LOCK</b>	F81032-2	26
11	<b>WEDGE WELDMENT, LOG TAPER</b>	086035-1	

## 2.2 Sawmill Frame Fasteners

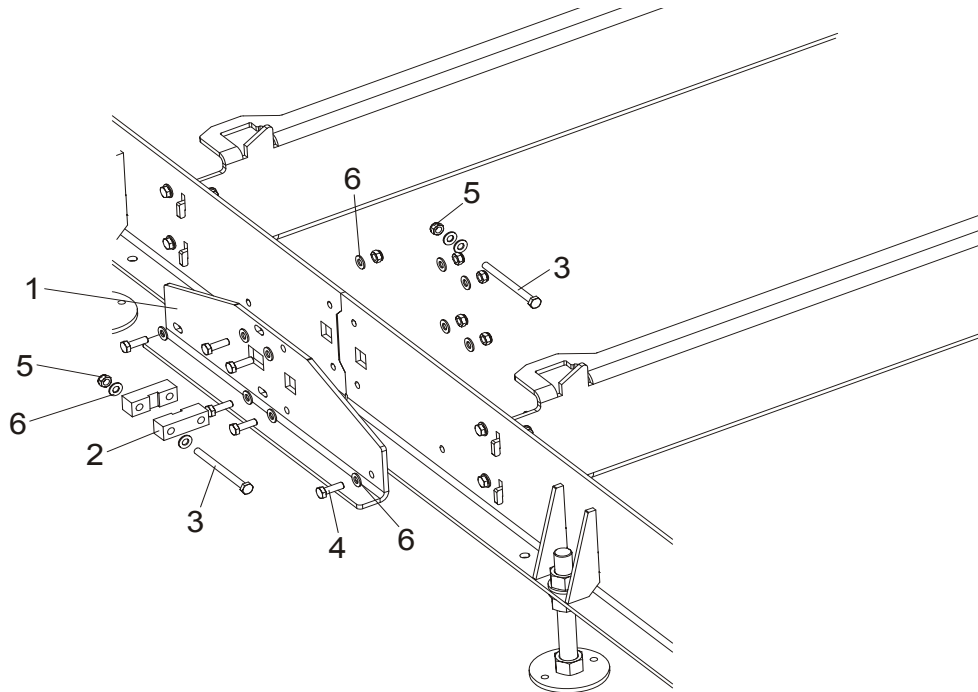

REF	DESCRIPTION (◆Indicates Parts Available In Assemblies Only)	Part #	Qty.
1	PLATE, BED RAILS CONNECTING LT10 ZINC	097185-1	1 <sup>1</sup>
2	BLOCK, FRAME CONTRACTING LT10 ZINC	097464-1	2
3	BOLT, M8X100-8.8 HEX HEAD ZINC	F81002-23	2
4	BOLT, M8x25-8.8-B HEX HEAD FULL THREAD ZINC	F81002-5	6
5	NUT, M8-8-B HEX NYLON ZINC LOCK	F81032-2	8
6	WASHER, 8.4 FLAT ZINC	F81054-1	16

<sup>1</sup> Frame with three bed sections contains six connecting assemblies.

## 2.3 Frame Outriggers

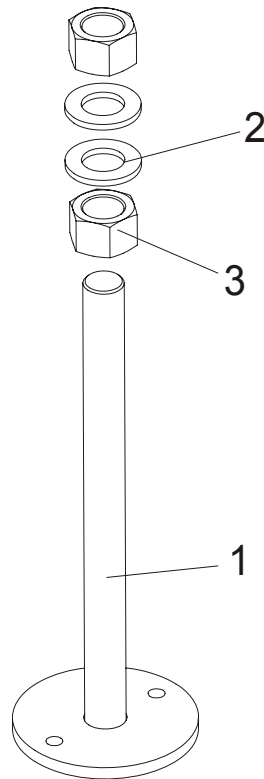

REF	DESCRIPTION (◆ Indicates Parts Available In Assemblies Only)	Part #	Qty.	
1	OUTRIGGER WELDMENT, LT10 ZINC-PLATED	094513-1	1	
2	WASHER, 21 FLAT ZINC	F81059-2	2	
3	NUT, M20-8 HEX ZINC	F81037-1	2	

## 2.4 Log Clamp Assembly

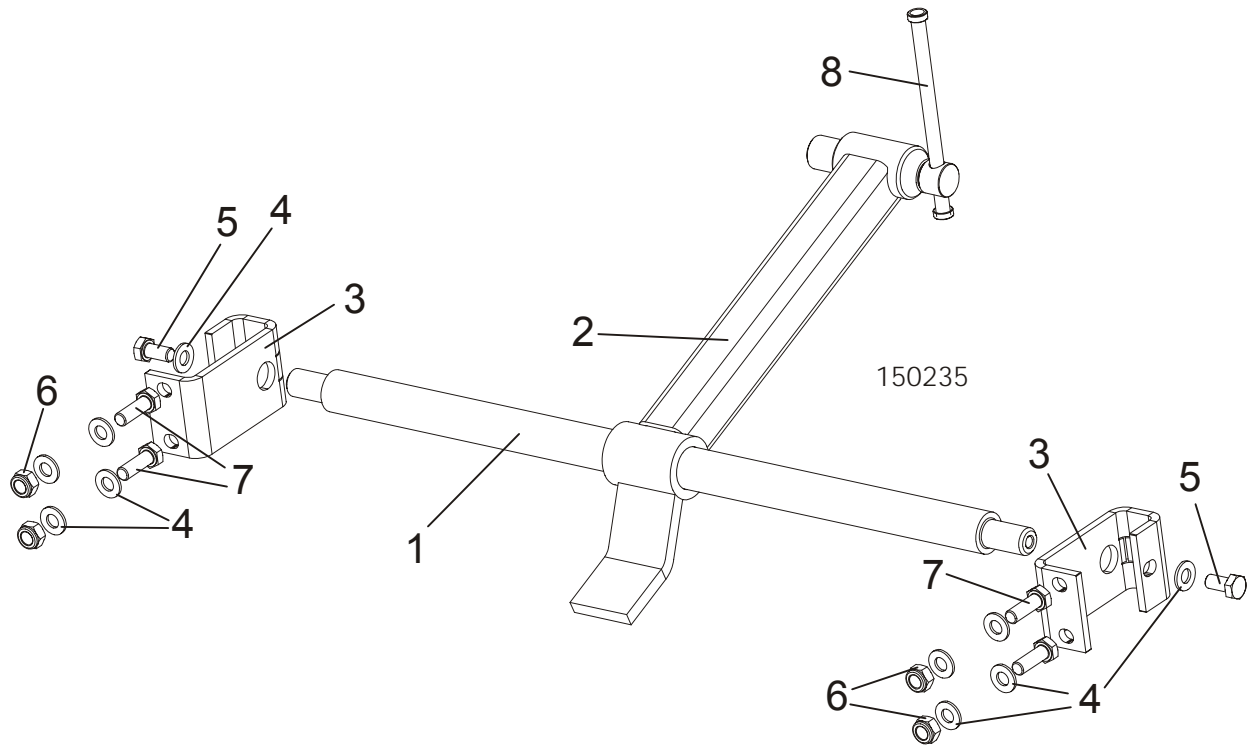

REF	DESCRIPTION (◆ Indicates Parts Available In Assemblies Only)	PART #	QTY.	
	<b>LOG CLAMP ASSEMBLY, LT10/15 COMPLETE</b>	<b>507565</b>	<b>2</b>	
1	ROD MAIN CLAMP	500343-1	1	
2	CLAMP ARM	507566-1	1	
3	BRACKET, LOG CLAMP MOUNT ZINC	506535-1	2	
4	WASHER, 10.5 FLAT ZINC	F81055-1	10	
5	BOLT, M10x20MM,HEX HEAD,GR 5.8 ZINC	F81003-1	2	
6	NUT,M10-8-B NYLON HEX ZINC LOCK	F81033-1	4	
7	BOLT,M10X30-5.8 HEX HEAD FULL THREA	F81003-2	4	
8	CLAMP BOLT KPL.	507563	1	

## 2.5 Log Wedge, Loading Ramps &amp; Cant Hook (Optional)

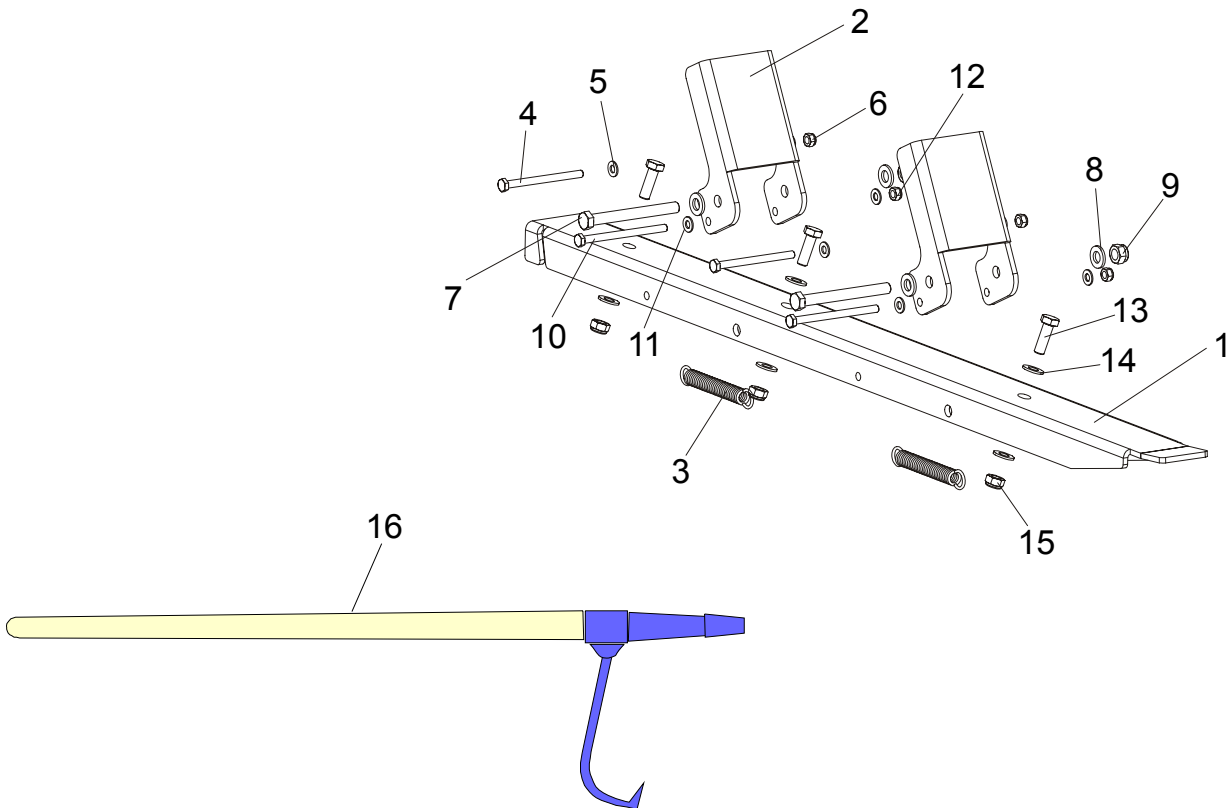

REF	DESCRIPTION (◆Indicates Parts Available In Assemblies Only)	Part #	Qty.
	<b>RAMP ASSEMBLY, LOG LOADING</b>	097483	2
1	Blacha nośna rampy załadowniczej LT10-cynkowana	097481-1	1
2	Blacha zabezpieczająca rampy ,LT10	097482-1	2
3	Spring, FI 1,9 x FI 14,2 x 104	091865	2
4	Bolt, M8x100 -8.8 Hex Head Zinc	F81002-23	2
5	Washer, 8.4 Flat Zinc	F81054-1	8
6	Nut, M8-8-B Hex Nylon Zinc Lock	F81032-2	4
7	Bolt, M12x115-8.8 Hex Head Zinc	F81004-33	2
8	Washer, 13 Flat Zinc	F81056-1	4
9	Nut, M12-8 Hex Nylon Zinc Lock	F81034-2	2
10	Bolt M10x110 8.8	F81003-43	2
11	Washer 10,5	F81055-1	2
12	NutM10-8-B	F81033-1	2
13	Bolt M16x40-8.8	F81006-13	3
14	Nut 17 Fe/Zn5	F81058-1	6
15	Washer M16-8-Fe/Zn5	F81036-2	3
16	<b>CANT HOOK</b>	CH	1



## 2.6 Bed Extension

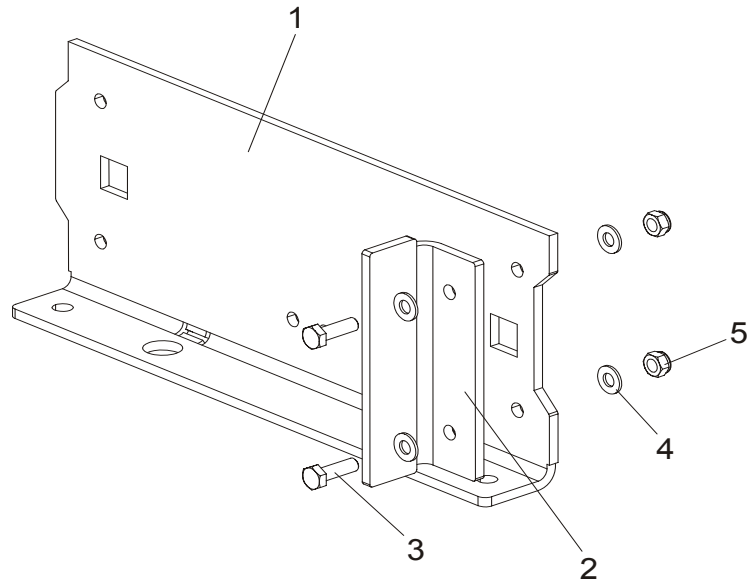

REF	DESCRIPTION (◆Indicates Parts Available In Assemblies Only)	Part #	Qty.	
1	EXTENSION, BED LT10 ZINC	097369-1	1	
2	STOP, SAW HEAD LT10 ZINC	097473-1	2	
3	BOLT, M8x25-8.8-B HEX HEAD FULL THREAD ZINC	F81002-5	2	
4	WASHER, 8.4 FLAT ZINC	F81054-1	4	
5	NUT, M8-8-B HEX NYLON ZINC LOCK	F81032-2	2	

**2.7 Bed Section LT10**

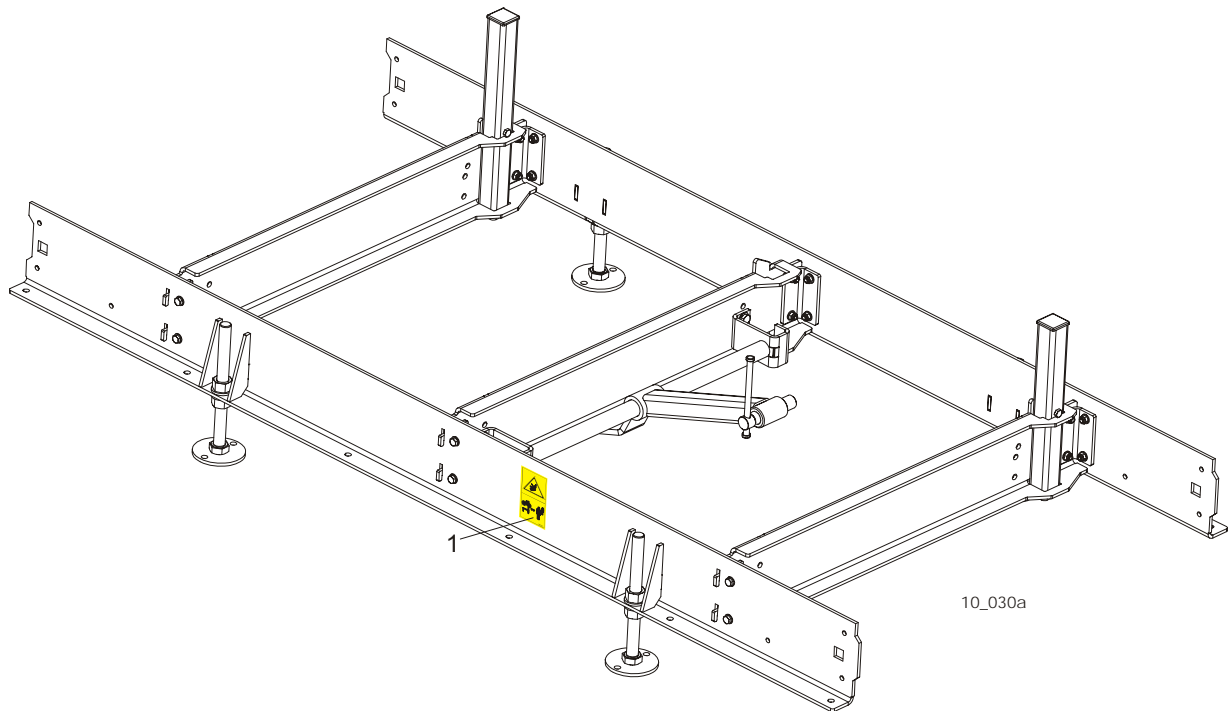

REF	DESCRIPTION (◆Indicates Parts Available In Assemblies Only)	Part #	Qty.
	<b>BED SECTION, LT10 COMPLETE</b>	097467	3 <sup>1</sup>
1	<b>DECAL, KEEP AWAY DANGER, PICTOGRAM</b>	099221	1

<sup>1</sup> Number of bed sections depends on sawmill version.

**SECTION 3 BLADE GUIDE ROLLERS & ARM**

**3.1 Blade Guide Assembly, Idle Side**

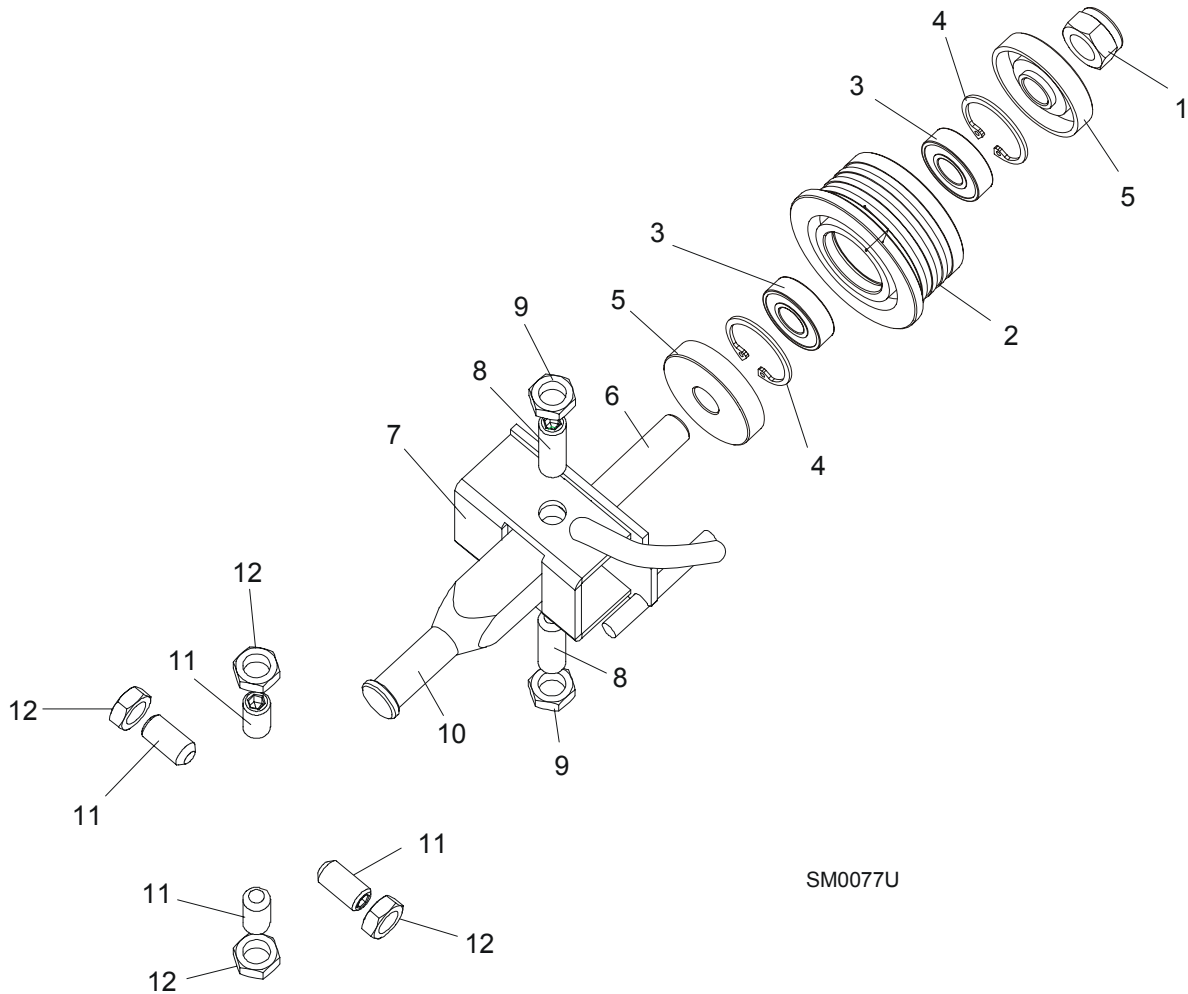

SM0077U

REF	DESCRIPTION (◆ Indicates Parts Available In Assemblies Only)	Part #	Qty.	
	<b>BLADE GUIDE ASSEMBLY, IDLE SIDE</b>	094683	1	
	Roller Assembly, Standard Blade Guide	087887	1	
1	Nut, M12-8 Hex Nylon Lock Nut	F81034-2	1	
2	Roller, Narrow Blade Guide	087889	1	◆
3	Bearing, 6001 2RSR FAG	087893	2	
4	Ring, W28 Inside Retaining	F81090-9	1	
5	Washer, Zinc-plated Spacer	087891-1	2	
6	Shaft, Standard Blade Guide Roller Zinc	087763-1	1	
7	Bracket Weldment, Idle Side Blade Guide Painted	094681-1	1	
8	Screw, M10x1x40 DIN 913 A2-70 Stainless Steel Set	F81015-2	2	

**3****BLADE GUIDE ROLLERS & ARM***Blade Guide Assembly, Idle Side*

---

9	Nut, M10x1-04-ST-A2 ISO 8675 Thin	F81033-10	2	
10	Shaft, Zinc-plated Blade Guide Mount	088255-1	1	
11	<b>SCREW, M10X1X20 DIN 913 STAINLESS STEEL SET</b>	F81015-1	4	
12	<b>NUT, M10x1-04-ST-A2 ISO 8675 THIN</b>	F81033-10	4	

### 3.2 Blade Guide Assembly, Drive Side

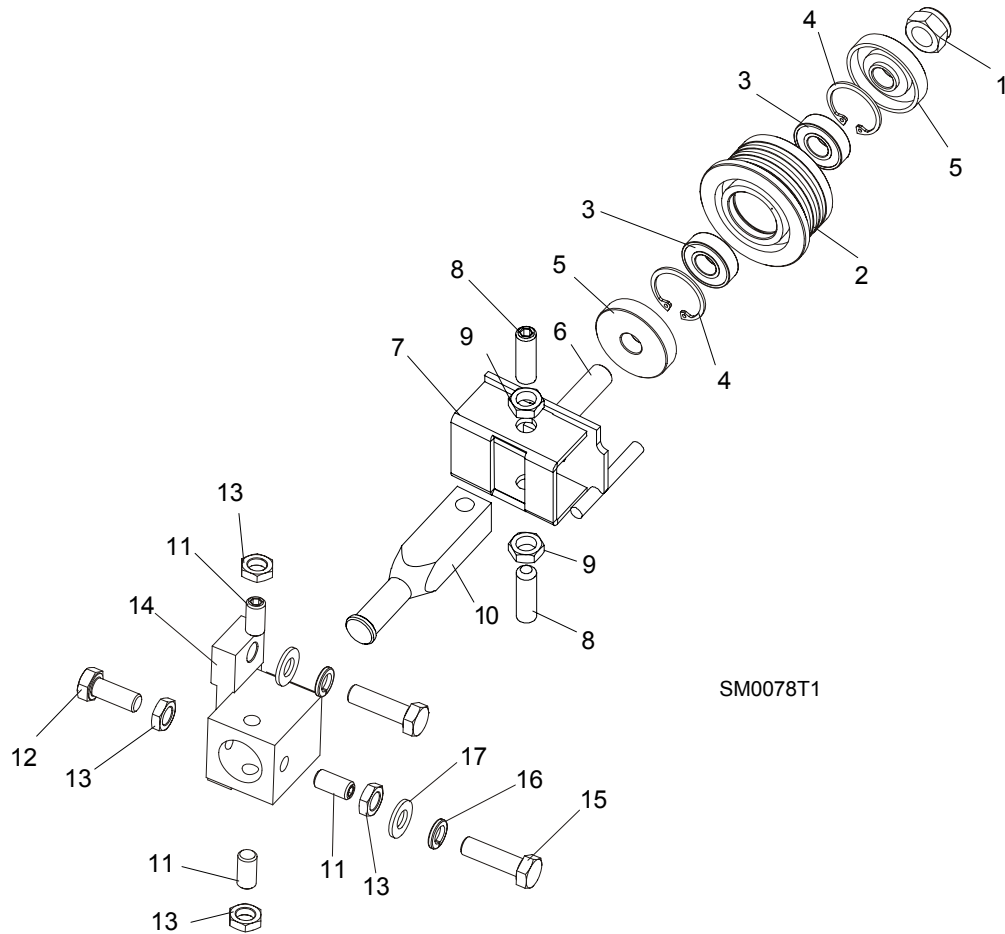

REF	DESCRIPTION (◆ Indicates Parts Available In Assemblies Only)	Part #	Qty.	
	<b>BLADE GUIDE ASSEMBLY DRIVE SIDE</b>	094682	1	
	Roller Assembly, Standard Blade Guide	087887	1	
1	Nut, M12-8 Hex Nylon Lock Nut	F81034-2	1	
2	Roller, Narrow Blade Guide	087889	1	◆
3	Bearing, 6001 2RSR FAG	087893	2	
4	Ring, W28 Inside Retaining	F81090-9	1	
5	Washer, Zinc-plated Spacer	087891-1	2	
6	Shaft, Standard Blade Guide Roller Zinc	087763-1	1	
7	Bracket Weldment, Blade Guide Painted	094679-1	1	
	Screw Kit, Blade Guide Adjustment w/Nuts (for two blade guide assemblies)	K09942	1	
8	Screw, M10x1x40 DIN 913 A2-70 Stainless Steel Set	F81015-2	2	
9	Nut, M10x1-04-ST-A2 ISO 8675 THIN	F81033-10	2	
10	Shaft, Zinc-plated Blade Guide Mount	088255-1	1	

**3****BLADE GUIDE ROLLERS & ARM***Blade Guide Assembly, Drive Side*

---

11	SCREW, M10X1X20 DIN 913 SET STAINLESS STEEL	F81015-1	3	
12	BOLT, M10X1X25 DIN 933 STAINLESS STEEL	F81003-28	1	
13	NUT, M10x1-04-ST-A2 ISO 8675 THIN	F81033-10	4	
14	TUBE, BLADE GUIDE MOUNT	087744	1	
15	BOLT, M10X35-8.8 HEX HEAD FULL THREAD ZINC	F81003-17	2	
16	WASHER, 10.2 SPLIT LOCK ZINC	F81055-2	2	
17	WASHER, 10.5 FLAT ZINC	F81055-1	2	

**3.3 Blade Guide Roller Guard**

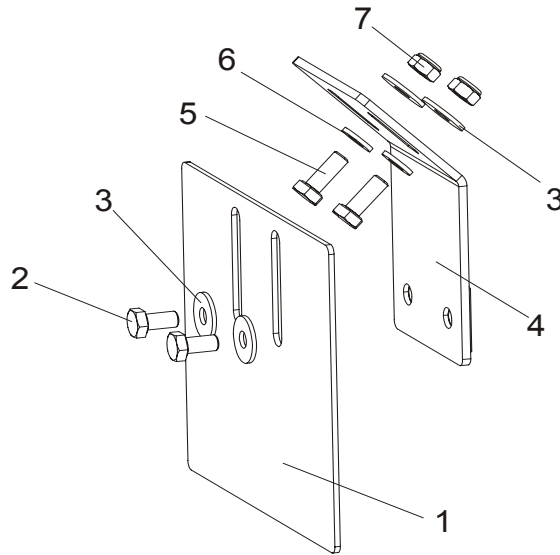

REF	DESCRIPTION (◆ Indicates Parts Available In Assemblies Only)	Part #	Qty	
1	GUARD, BLADE GUIDE ROLLER PAINTED	092379-1	1	
2	BOLT, M6X12-8.8 HEX HEAD FULL THREAD ZINC	F81001-7	2	
3	WASHER, 6,5 SPECIAL FLAT ZINC	F81053-11	4	
4	BRACKET, ROLLER GUARD MOUNT PAINTED	092378-1	1	
5	SCREW, M6X16 8.8 HEX HEAD FULL THREAD ZINC	F81001-15	2	
6	WASHER, 6.4 FLAT ZINC	F81053-1	2	
7	NUT, M6-8-B HEX NYLON ZINC LOCK	F81031-2	2	

**3.4 Blade Guide Arm Assembly**

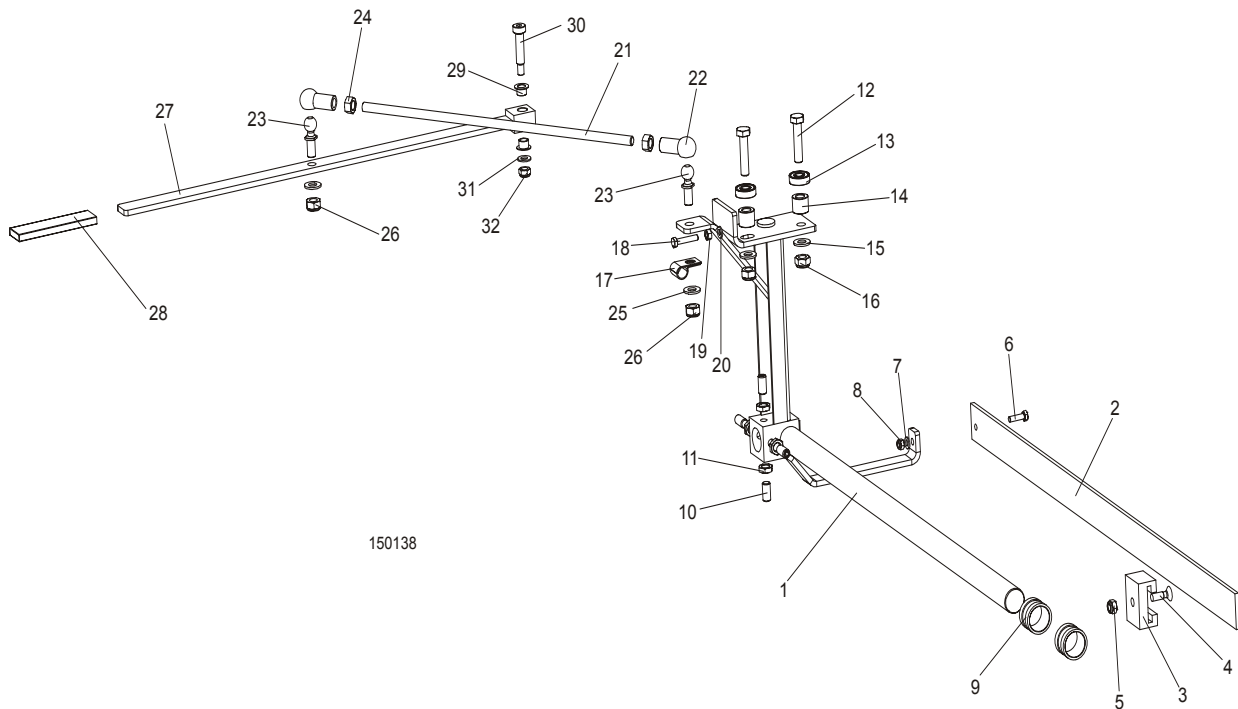

REF	DESCRIPTION (◆ Indicates Parts Available In Assemblies Only)	Part #	Qty
	<b>BLADE GUIDE ARM W/LEVER - COMPLETE</b>	094136	1
1	Arm weldment, LT10 Blade Guide	086662	1
2	Bar, Blade Guard	088306	1
3	Guide, Blade Guard	088305	1
4	Screw, M8x25 Cross Recessed Countersunk Head Zinc	F81002-51	1
5	Nut, M8-8-B-FeZn5 Hex Nylon Zinc Lock	F81032-2	1
6	Bolt, M6x20-8.8 Hex Head Full Thread Zinc	F81001-2	1
7	Washer, 6.4 Flat Zinc	F81053-1	1
8	Nut, M6-8-B Hex Nylon Zinc Lock	F81031-2	1
9	Bushing, LT10 Blade Guide	086684	1
10	Screw, M10x1x20 DIN913 Set Stainless Steel	F81015-1	4
11	NUT, M10x1-04-ST-A2 ISO 8675 Thin	F81033-10	4
12	Bolt, M10x45-8.8 Hex Head Full Thread Zinc	F81003-3	2
13	Bearing 6000.2RSR FAG	087471	2
14	Bushing, Zinc-Plated Spacer	094255-1	2
15	Washer, 10.5 Flat Zinc	F81055-1	2
16	Nut, M10-8-B Hex Nylon Zinc Lock	F81033-1	2
17	Clamp, 1/2" EMT Coated	P07584	1
18	Bolt, M6x30 5.8 Hex Head Full Thread	F81001-13	1
19	Nut, M16-8 Hex Nylon Zinc Lock	F81031-1	1
20	Washer, 6.4 Flat Zinc	F81053-1	1
	Stud Bolt Assembly, Arm Lever Connection	094204	1



**BLADE GUIDE ROLLERS & ARM***Blade Guide Arm Assembly***3**

21	Bolt, Zinc-Plated Stud	094203-1	1	
22	Seat, 16 DIN71805-A BN488 Ball	093824	2	
23	Stud, 16/SW-13 DIN71803-C BN486 BALL	093823	2	
24	Nut, M10-8-B Hex Zinc	F81033-3	2	
25	Washer, 10.5 Flat Zinc	F81055-1	2	
26	Nut, M10-8-B Hex Nylon Zinc Lock	F81033-1	2	
	Lever Assembly, Blade Guide Arm Adjustment	093812	1	
27	Lever, Blade Guide Arm Adjustment Painted	093813-1	1	
28	Cover, RRWA-91626-110 Grip	086875	1	
29	Bushing, TUF1 18X120 CX	500106	2	
30	Bolt, 10/M8x35 12.9 ISO7379 Shoulder	F81003-63	1	
31	Washer, 8.4 Flat Zinc	F81054-1	1	
32	Nut, M8-8-B hex nylon zinc lock	F81032-2	1	

## SECTION 4 BLADE WHEELS &amp; TENSIONER

## 4.1 Blade Wheel Assembly, Drive Side

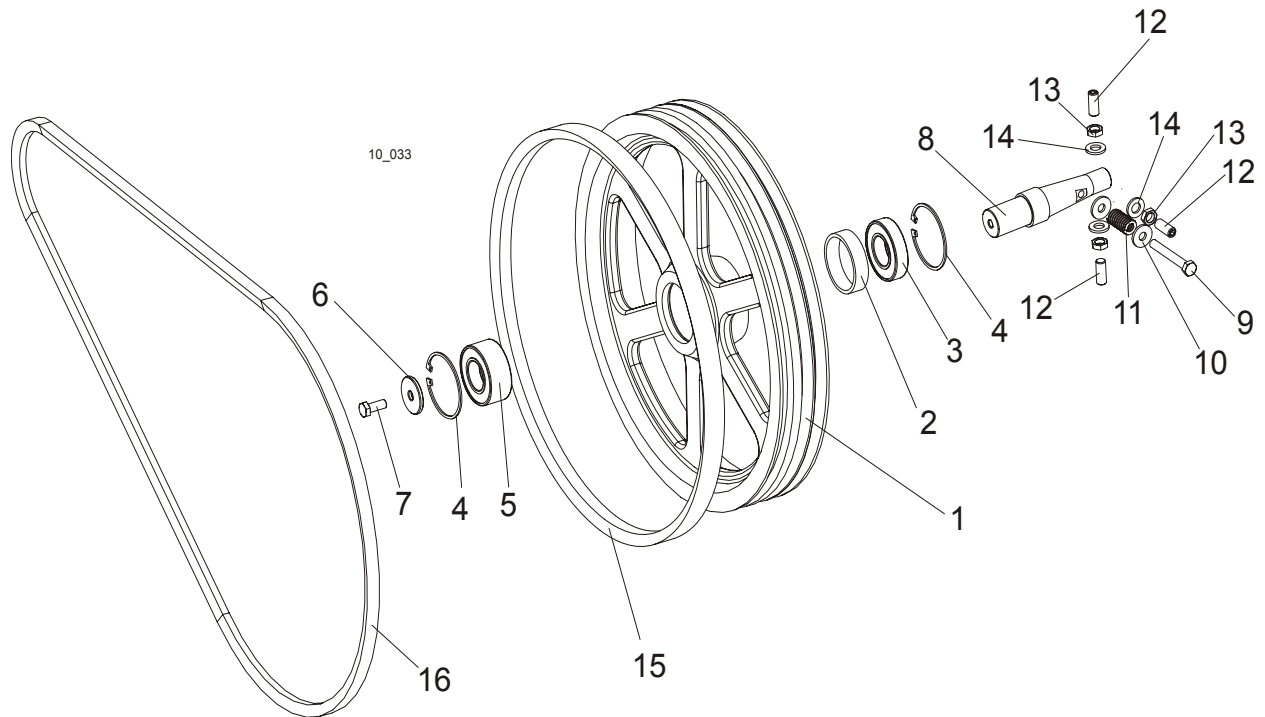

REF	DESCRIPTION (◆ Indicates Parts Available In Assemblies Only)	PART #	QTY.
	<b>WHEEL ASSEMBLY, DRIVE SIDE BLADE</b>	091612	1
1	BLADE WHEEL, DRIVE SIDE PTD	090646-1	1
2	BUSHING, SPACER	096778	1
3	BEARING, 6207 2RS 35X72X17 FAG	014811	1
4	RING, W72 INSIDE RETAINING	F81090-4	2
5	BEARING, 3207B, 2RSR TVH FAQ	P04185	1
6	WASHER, DRIVE SIDE BLADE WHEEL	092006	1
7	SCREW, M10X25-8.8 HEX HEAD FULL THREAD ZINC	F81003-11	1
8	SHAFT, DRIVE SIDE BLADE WHEEL	093850	1
9	BOLT, M10X75-8.8 HEX HEAD ZINC	F81003-15	1
10	WASHER, 10.5 SPECIAL FLAT ZINC	F81055-6	2
11	SPRING, 19X38 COMPRESSION	034430	1
12	SCREW, M12X1,25X30 DIN913 SET STAINLESS STEEL	F81016-1	3
13	WASHER, 13 FLAT ZINC	F81056-1	3
14	NUT, M12X1.25 DIN439 THIN STAINLESS STEEL	F81034-9	3
15	V-BELT, B57	P04185	1
16	DRIVE BELT, BX81	014819	1

**4.2 Blade Wheel Assembly, Idle Side**

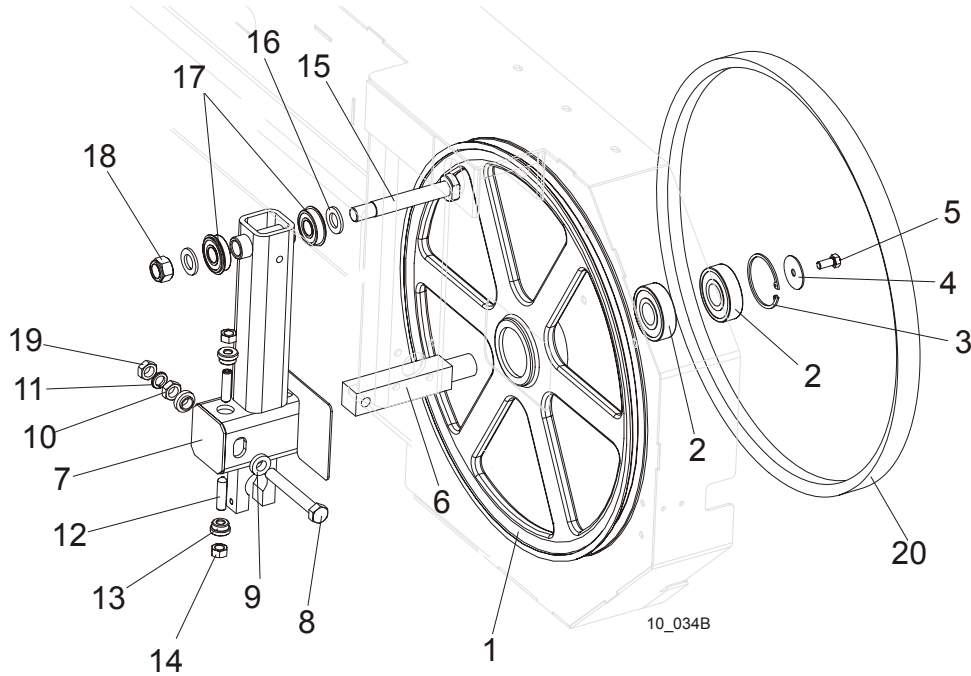

REF	DESCRIPTION (◆ Indicates Parts Available In Assemblies Only)	PART #	QTY.
	<b>WHEEL ASSEMBLY, IDLE SIDE BLADE</b>	A08218	1
1	WHEEL ASSEMBLY, 18.62" BLADE IDLE SIDE	P08125	1
2	BEARING, 6305 2RS NSK IDLE SIDE WHEEL	P08066	2
3	RING, 2 7/16" INSIDE RETAINING	F04254-21	1
	<b>HOUSING, LT10 &amp; LT15 IDLER SHAFT, COMPLETE</b>	100180	1
4	WASHER, IDLE SIDE WHEEL RETAINING	093854-1	1
5	BOLT, M8X25-8.8-B HEX HEAD FULL THREAD ZINC	F81002-5	1
6	SHAFT, IDLE SIDE BLADE WHEEL (METRIC)	096045	1
7	HOUSING, IDLER SHAFT	093857-1	1
8	BOLT, M12X1,25X100-8.8 HEX HEAD FULL THREAD ZINC	F81004-41	1
9	WASHER, FLANGED ZINC-PLATED	086769-1	2
10	NUT, M12X1,25 -8 HEX ZINC	F81034-8	1
11	WASHER, 12.2 SPLIT LOCK ZINC	F81056-2	1
12	SCREW, M10X40-45H CONE POINT HEX SOCKET	F81003-61	2
13	BUSHING, M10 IDLER SHAFT HOUSING	086987	2
14	NUT, M10-8-B HEX HEAD ZINC	F81033-3	2
15	PIN, IDLER ARM MOUNT	086404	1
16	WASHER, 17 FLAT ZINC	F81058-1	2
17	BEARING, 6203-2RS NR NSK W/SNAP RING	086395	2
18	NUT, M16-8 HEX NYLON ZINC LOCK	F81036-2	1
19	NUT, M12X1.25 DIN439 THIN STAINLESS STEEL	F81034-9	1
20	V-BELT, B57	P04185	1

# 4 BLADE WHEELS & TENSIONER

## Blade Tensioner Assembly

### 4.3 Blade Tensioner Assembly

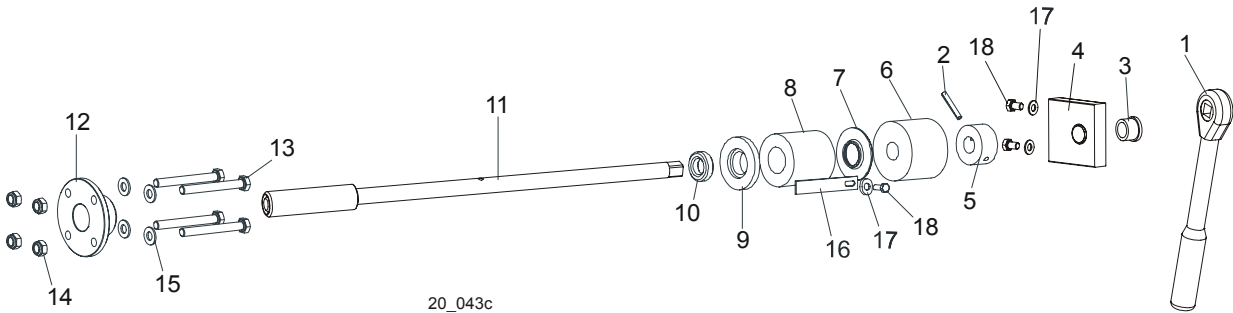

REF	DESCRIPTION (◆ Indicates Parts Available In Assemblies Only)	PART#	QTY.
	<b>BLADE TENSIONER ASSEMBLY</b>	090587	1
1	Wrench, LT20 Blade Tension	091620	1
2	Pin, 5 x 30 Zinc Roll	F81044-21	1
	Bracket, Tension Handle Mount w/Bushing	096729	1
3	Bushing GFM-1618-17(IGUS)	089589	1
4	Bracket, Painted	096730	1
5	Collar, Blade Tensioner	086712-1	1
6	Bushing, Rubber Stop	P12165	1
7	Guide, LT15 Tension Handle	014925	1
8	Spring, LT15 Rubber Blade Tensioner	014828	1
9	Washer, Rubber Spring Front	086674-1	1
10	Bearing, 51103 FLT Ball Thrust	086675	1
11	Shaft Weldment, Blade Tensioner Zinc-plated	101338-1	1
12	Nut, Blade Tensioner	086672-1	1
13	Bolt, M8x70 8.8 Hex Head Zinc	F81002-71	4
14	Nut, M8-8-B Hex Nylon Zinc Lock	F81032-2	4
15	Washer, 8.4 Zinc Flat	F81054-1	8
16	Indicator, LT15 Blade Tension Zinc-plated	086783-1	1
17	Washer, 6.4 Zinc Flat	F81053-1	1
18	Bolt, M6x16 8.8 Hex Head Full Thread Zinc	F81001-15	1

4.4 Motor

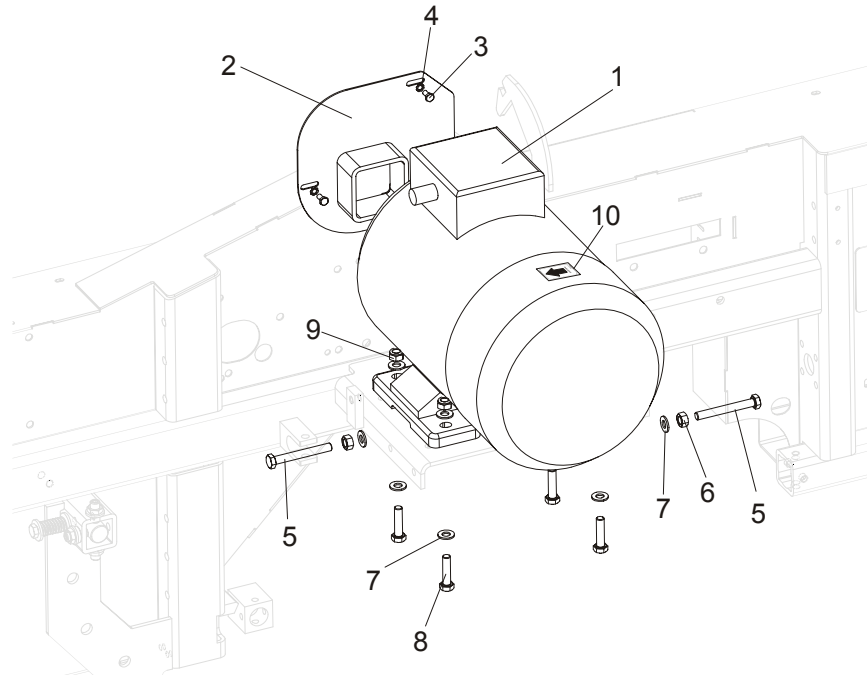

REF	DESCRIPTION (◆ Indicates Parts Available In Assemblies Only)	Part #	Qty.
1	MOTOR, 1LA7130-2AA60 5,5KW,400V,50HZ ELECTRIC	095785	1
2	MOTOR SHAFT COVER, E11 E15 PAINTED	095335-1	1
3	BOLT, M6X12-8.8 HEX HEAD FULL THREAD ZINC	F81001-7	3
4	WASHER, 6.4 STAR LOCK ZINC	F81053-2	3
5	BOLT, M10X80-8.8 HEX HEAD FULL THREAD ZINC	F81003-76	2
6	NUT, M10-8-B HEX ZINC	F81033-3	2
7	WASHER, 10.5 FLAT ZINC	F81055-1	10
8	BOLT, M10X40-8.8 HEX HEAD FULL THREAD ZINC	F81003-16	4
9	NUT, M10-8-B NYLON HEX ZINC LOCK	F81033-1	4
10	DECAL, ROTATION DIRECTION - 2925 RPM	S20097F <sup>1</sup>	1

<sup>1</sup> Included in 099419 - LT10 Pictographic Decal Kit.

**4.5 Power Cord Bracket**

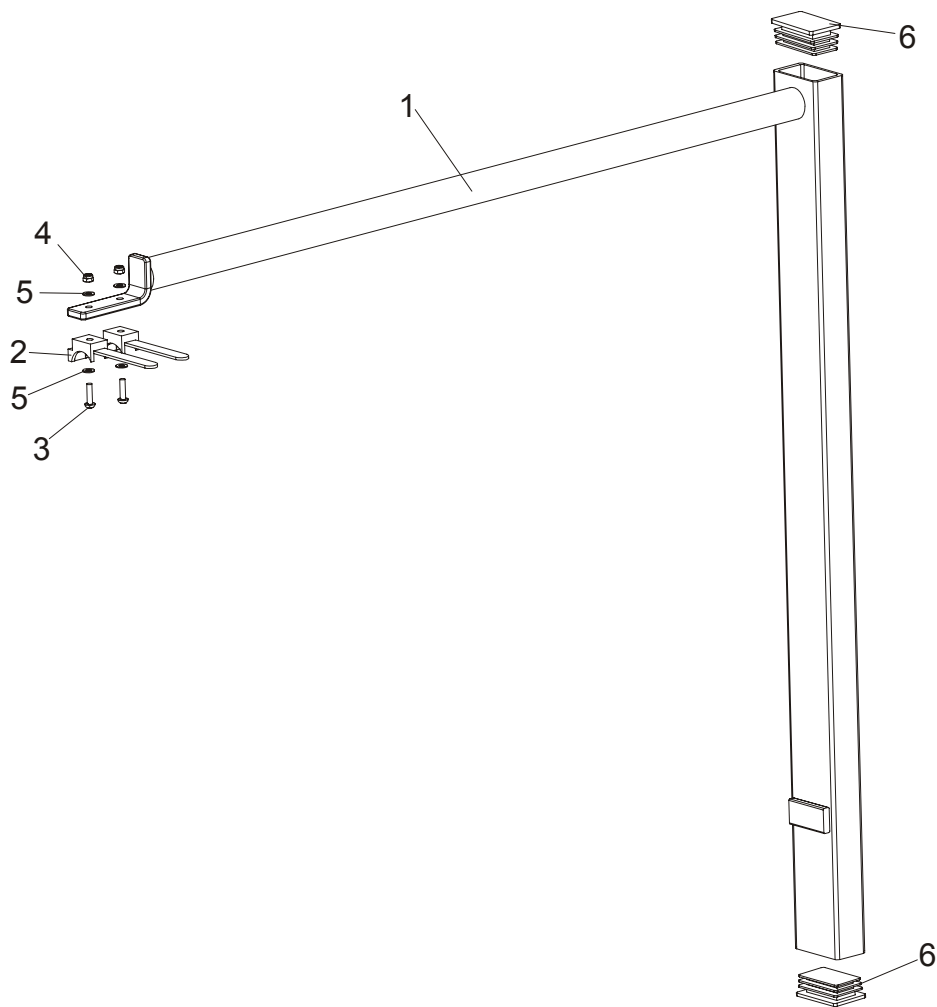

REF	DESCRIPTION (◆ Indicates Parts Available In Assemblies Only)	Part #	Qty.
	<b>BRACKET, LT10 POWER CORD COMPLETE</b>	097449	1
1	Bracket, Power Cord Painted LT10	086132-1	1
2	Holder, UP30 Cable Plastic Tie	F81082-1	2
3	Screw, M4x16 5,8-B Cross Recessed Pan Head Zinc	F81011-42	2
4	Nut, M4-B Hex Nylon Zinc Lock	F81029-1	2
5	Washer, 4.3 Flat Zinc	F81051-2	4
6	Cap, 50x30 Black	095919	2

## SECTION 5 SAW HEAD

### 5.1 Blade Housing Cover

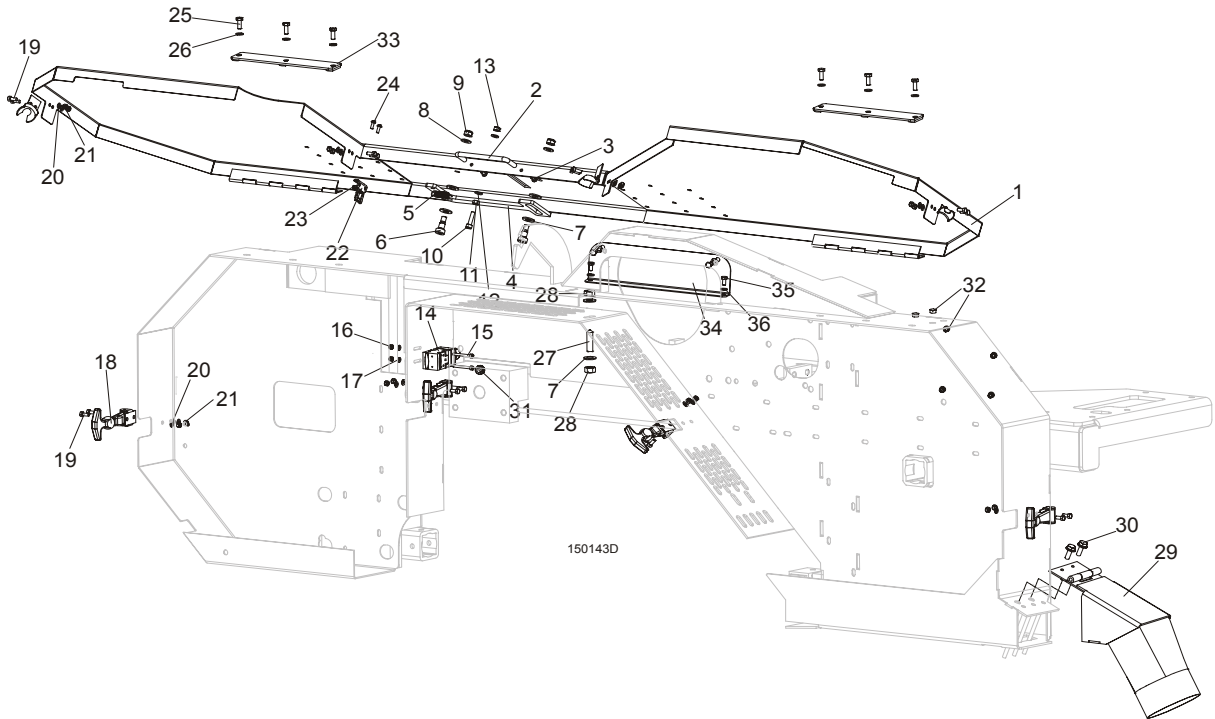

REF	DESCRIPTION (◆ Indicates Parts Available In Assemblies Only)	PART #	QTY.
	<b>COVER, LT15 FRONT COMPLETE</b>	098678	1
1	Cover Weldment, LT10/15/20 Blade Housing Painted	096776-1	1
2	Handle w/Bolt	P08065	1
3	Screw, #8-32x3/8 Self-tapping	F05015-8	2
4	Pawl, Locking Painted	090643-1	1
5	Spring, 1.6x12x38 Extension	092208	1
6	Bolt, 10/M8x12-12.9 ISO-7379 Shoulder	F81003-62	2
7	Washer, 10.5 Flat Zinc	F81055-1	4
8	Washer, 8.4 Flat Zinc	F81054-1	2
9	Nut, M8-8-B Hex Nylon Zinc Lock	F81032-2	2
10	Screw, M6x25-8.8 Hex Socket Head Cap Zinc	F81001-41	1
11	Nut, M6-8 Hex Zinc	F81031-1	1
12	Washer, 6.4 Flat Zinc	F81053-1	2
13	Nut, M6-8-B Hex Nylon Zinc Lock	F81031-2	1
14	<b>SWITCH, AZ17-11ZRK SAFETY</b>	094232	1
15	<b>SCREW, M4X35-8.8 HEX SOCKET HEAD CAP ZINC</b>	F81011-34	2
16	<b>NUT, M4-B HEX NYLON ZINC LOCK</b>	F81029-1	2

17	WASHER, 4.3 FLAT ZINC	F81051-2	2	
18	LATCH, FLEXIBLE DRAW	014829	4	
19	BOLT, M5X12-5.8 HEX HEAD FULL THREAD ZINC	F81000-5	8	
20	WASHER, 5.3 FLAT ZINC	F81052-1	8	
21	NUT, M5-8 DIN 985 ZINC-PLATED	F81030-2	8	
22	KEY, A217/170-B5 SAFETY SWITCH	094422	1	
23	NUT, M4-B HEX NYLON ZINC LOCK	F81029-1	2	
24	SCREW, M4X12-5.8-B CROSS RECESSED PAN HEAD ZINC	F81011-43	2	
25	BOLT, M6X16 8.8 HEX HEAD FULL THREAD ZINC	F81001-15	6	
26	WASHER, 6.4 FLAT ZINC	F81053-1	6	
27	SCREW, M10X40-45H HEX SOCKET SET CONE POINT ZINC	F81003-61	1	
28	NUT, M10-8-B HEX ZINC	F81033-3	2	
29	CHUTE, LT10/15/20 SAWDUST	100903-1	1	
30	BOLT, M8X16-8.8-B HEX HEAD FULL THREAD ZINC	F81002-20	2	
31	GROMMET, 22mm DIA. RUBBER	087400	1	
32	PLUG, SR1086-9,5	096846	6	
33	PLATE, COVER MOUNT	086701-1	2	
34	COVER, SAW HEAD MOUNT	096788-1	1	
35	BOLT, M6X12MM HEX HEAD ZINC	F81001-7	4	
36	WASHER, M6 FLAT ZINC	F81053-1	4	



**5.2 Water Lube Assembly**

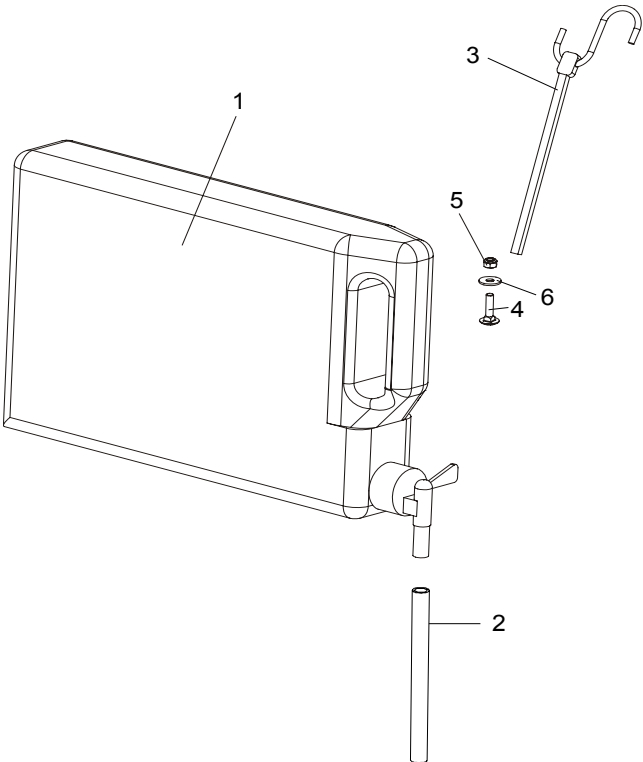

REF	DESCRIPTION (◆ Indicates Parts Available In Assemblies Only)	Part #	Qty.	
1	Bottle, 5-liter Water	049119	1	
2	Tube, 3/8" I.D. Water Lube	R01885	1,7 m	
3	Strap, 24" Rubber w/Hook	P11258	2	
4	Bolt, M6x25-8.8 Mushroom Head Square Neck Zinc	F81001-20	1	
5	Nut, M6-8-B Hex Nylon Zinc Lock	F81031-2	1	
6	Washer, 6.5 Special Flat Zinc	F81053-11	1	

## 5.3 LT10 Saw Head Decals

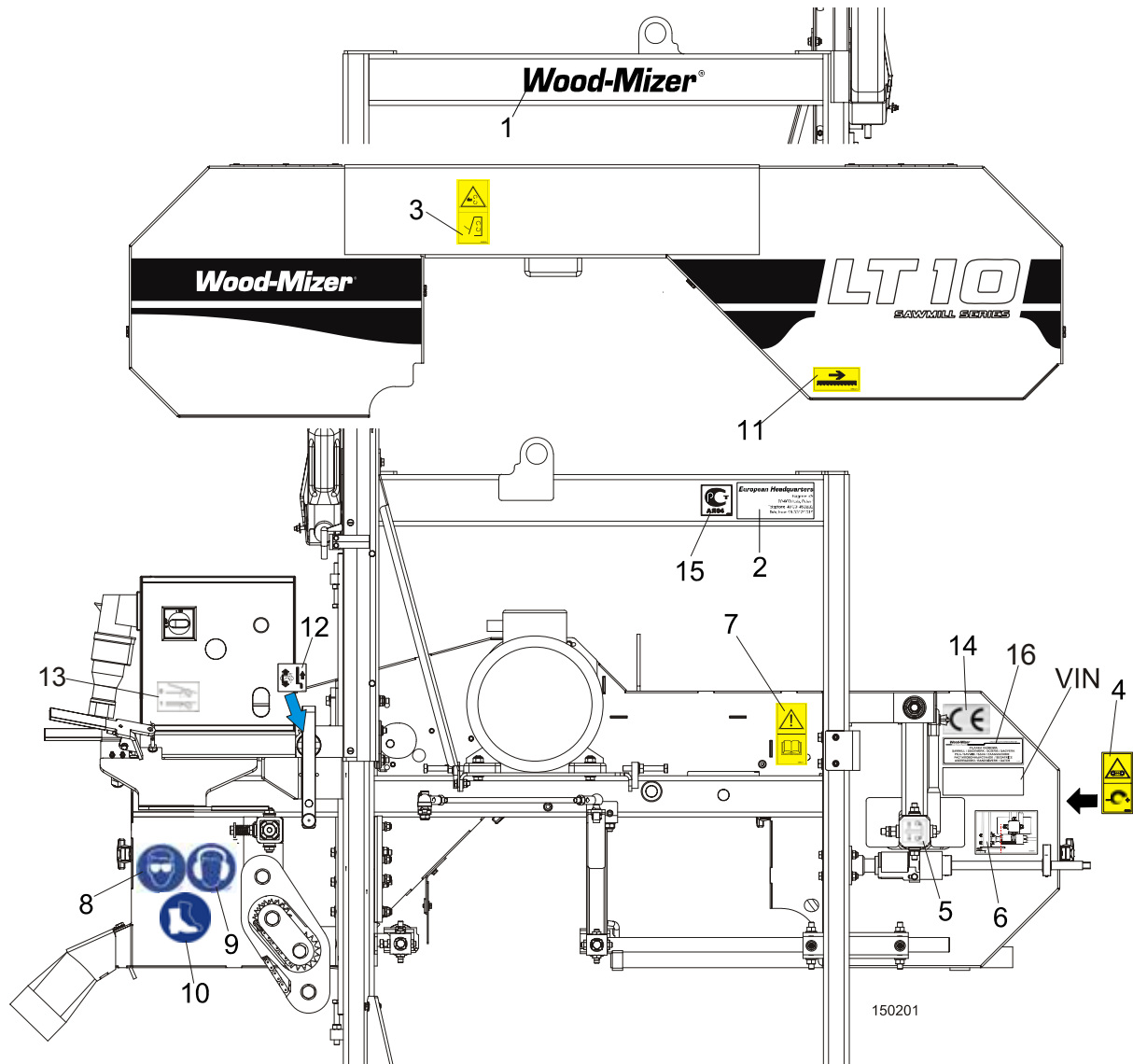

REF	DESCRIPTION (◆ Indicates Parts Available In Assemblies Only)	Part #	Qty.
	<b>PICTOGRAPHIC DECAL KIT, LT10</b>	099419	1
	Decal, LT10 sawmill name	098109	1
1	DECAL, WOOD-MIZER	S12281	1
2	DECAL, EUROPEAN HEADQUARTERS ADDRESS	015841	1
3	DECAL, SAWMILL COVERS CAUTION	099220	1
4	DECAL, BLADE TENSION (PICTOGRAM)	099219	1
5	DECAL, BLADE ALIGNMENT	P11789	1
6	DECAL, BLADE TENSION INDICATOR ADJUSTMENT	092597	1
7	DECAL, READ OPERATOR'S MANUAL (PICTOGRAM)	096317	1
8	DECAL, EYE PROTECTION WARNING (PICTOGRAM)	S12004G	1
9	DECAL, EAR PROTECTION WARNING (PICTOGRAM)	S12005G	1

<b>10</b>	DECAL, USE SAFETY BOOTS (PICTOGRAM)	501465	1	
<b>11</b>	DECAL, BLADE MOVEMENT DIRECTION (PICTOGRAM)	096321	1	
<b>12</b>	DECAL, POWER FEED SYSTEM ENGAGEMENT (PICTOGRAM)	099226	1	
<b>13</b>	DECAL, SAFETY HANDLE	501477	1	
<b>14</b>	<b>DECAL, CE CERTIFIED SAWMILL (SMALL)</b>	P85070	1	
<b>15</b>	<b>DECAL, RUSSIAN SAFETY CERTIFICATION</b>	099401	1	
<b>16</b>	<b>DECAL, INTERNATIONAL SAWMILL NAME</b>	501466	1	

### 5.4 Control Box

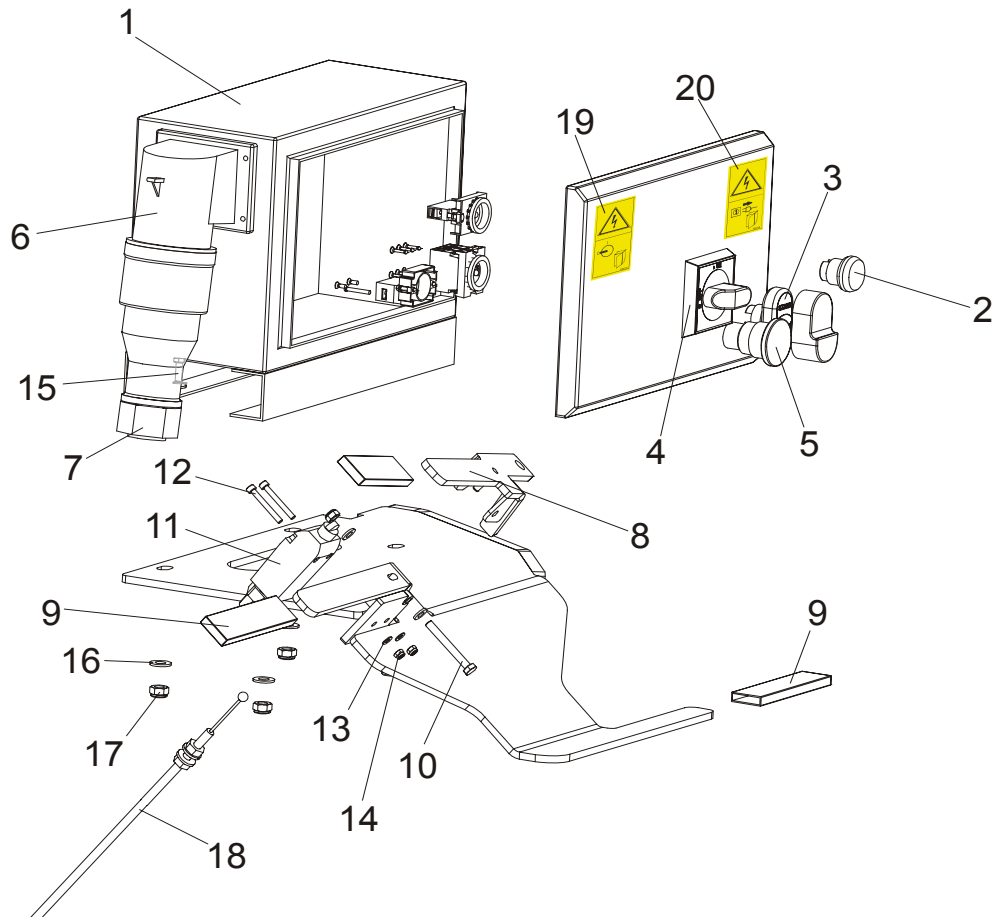

REF	DESCRIPTION (◆ Indicates Parts Available In Assemblies Only)	Part #	Qty.
	<b>BOX, LT10 ELECTRIC</b>	<b>096001-M</b>	1
	<b>BOX, LT10 ELECTRIC (NORWEGIAN VERSION)</b>	<b>096001-M2</b>	1
1	Box, Electric	092628	1
2	Light, M22 White-LED 24V Control	090448	1
3	Start/Stop Switch 24V	090452	1
4	Switch, ABB OT40 F3	502312	1
	Knob, OHB S2A1 ABB Switch	502312-1	1
	Axle, OXS6160 ABB Switch	502312-2	1
5	Switch, XB4 BS542 Emergency Stop	086556	1
6	Plug, 16A	E85239	1
7	Plug in socket, 16A 400V IP57 31243 Bals	E85240	1
8	<b>HANDLE, BLADE ENGAGEMENT WLDMT/PTD</b>	097221-1	1
9	<b>COVER, RRWA-91626-110 GRIP</b>	086875	3
10	<b>BOLT, M6X50-8.8 HEX HEAD ZINC</b>	F81001-62	1
11	<b>SWITCH, GLCB01C LIMIT</b>	100910	1
12	<b>SCREW, M4X35 -8.8 HEX SOCKED HEAD CAP ZINC</b>	F81011-34	2
13	<b>WASHER, 4.3 FLAT ZINC</b>	F81051-2	2

14	NUT, M4-B HEX NYLON ZINC LOCK	F81029-1	2	
15	BOLT, M8X25-8.8-B HEX HEAD FULL THREAD ZINC	F81002-5	4	
16	WASHER, 8.4 FLAT ZINC	F81054-1	8	
17	NUT, M8-8-B HEX NYLON ZINC LOCK	F81032-2	4	
18	CABLE, THROTTLE	089450	1	
19	DECAL, HIGH VOLTAGE INSIDE THE ELECTRIC BOX (PICTOGRAM)	096316	1	
20	DECAL, REMOVE THE PLUG BEFORE OPENING THE BOX (PICTOGRAM)	096319	1	

## SECTION 6 FEED SYSTEM

### 6.1 Track Rail, Rollers & Travel Pins

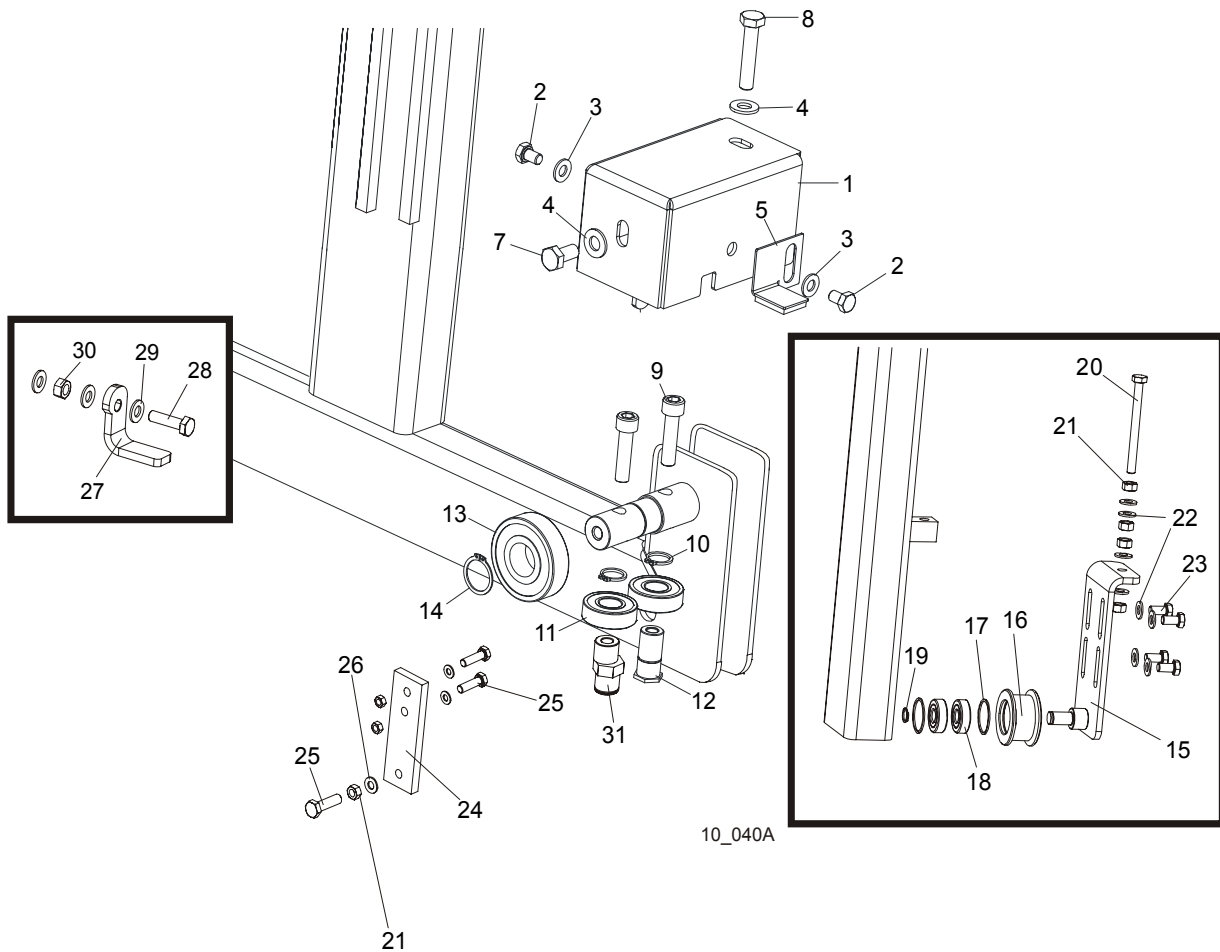

REF	DESCRIPTION (◆ Indicates Parts Available In Assemblies Only)	Part #	Qty.
1	COVER, TRACK ROLLER	086739-1	2
2	BOLT, M8X12-8.8 HEX HEAD FULL THREAD ZINC	F81002-6	6
3	WASHER, 8,4 FLAT ZINC	F81054-1	8
4	WASHER, 10,5 FLAT ZINC	F81055-1	13
5	PLATE, LEFT TRACK WIPER	086323	2
6	PLATE, RIGHT TRACK WIPER	086322	2
7	BOLT, M10 X 20 5.8 HEX HEAD FULL THREAD ZINC	F81003-1	2
8	BOLT, M10X50-8.8 HEX HEAD FULL THREAD ZINC	F81003-4	2
9	SCREW, M10X40 HEX SOCKET HEAD CAP ZINC	F81003-22	4
10	RING,Z 17 OUTSIDE RETAINING	F81090-21	4
11	BEARING, 6203-2RS ROLLING	086114	4

12	<b>SHAFT, SIDE BEARING MOUNT ZINC-PLATED</b>	086645-1	2	
13	<b>BEARING, 6305 2RSCX</b>	085706	2	
14	<b>RING, 25Z OUTSIDE RETAINING</b>	F81090-22	2	
15	<b>ROLLER, LT10 UPPER TRACK W/BRACKET</b>	097229	1	
16	Bracker, Upper Track Roller, Idle Side LT10	097228-1	1	
17	Ring, SW32 Outside Retaining	089062	2	
18	Bearing, 6201 2RS	089060	2	
19	Riing, Z12 Outside Retaining	F81090-14	1	
20	<b>BOLT, M8X90-8.8 HEX HEAD FULL THREAD ZINC</b>	F81002-16	1	
21	<b>NUT, M8-8-B HEX ZINC</b>	F81032-1	7	
22	<b>WASHER, 8.4 FLAT ZINC</b>	F81054-1	8	
23	<b>BOLT, M8X16-8.8-B HEX HEAD FULL THREAD ZINC</b>	F81002-20	4	
24	<b>BRACKET, SIDE</b>	097248-1	1	
25	<b>BOLT, M10X35-8.8 HEX HEAD FULL THREAD ZINC</b>	F81003-17	3	
26	<b>WASHER, 10.5 FLAT ZINC</b>	F81055-1	3	
27	<b>LATCH, SAW HEAD LT10</b>	097567-1	1	
28	<b>BOLT, M8X30-8.8-B HEX HEAD FULL THREAD ZINC</b>	F81002-7	1	
29	<b>WASHER, 8.4 FLAT ZINC</b>	F81054-1	3	
30	<b>NUT, M8-8-B HEX ZINC</b>	F81032-1	1	
31	<b>SHAFT, OUTER ECCENTRIC E=3,3-ZINC</b>	098898-1	2	

## 6.2 Track Rail, Rollers & Travel Pins

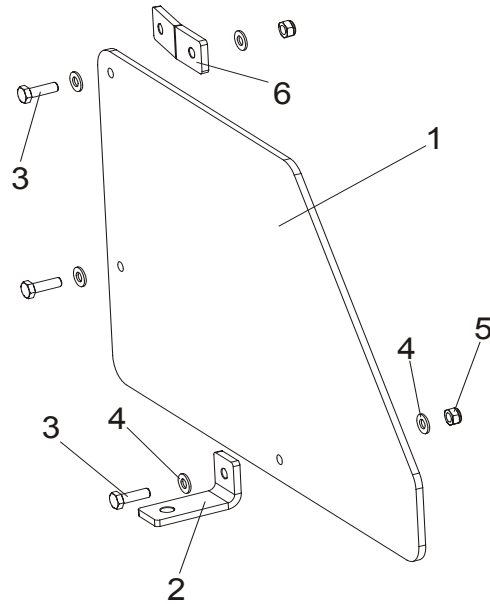

REF	DESCRIPTION (◆ Indicates Parts Available In Assemblies Only)	Part #	Qty.
	<b>GUARD, LT10 COMPLETE LOWER</b>	093858	1
1	Plate, LT10 Lower Guard	093859	1
2	Bracket, Lower PTD	086172-1	1
3	Bolt, M8x25-8.8 Hex Head Full Thread	F81002-5	3
4	Washer, 8.4 Flat Zinc	F81054-1	6
5	Nut, M8-8-B Hex Nylon Zinc Lock	F81032-2	3
6	Bracket, Side PTD	086171-1	2



**SECTION 7 UP/DOWN SYSTEM**

**7.1 Up/Down Crank Assembly**

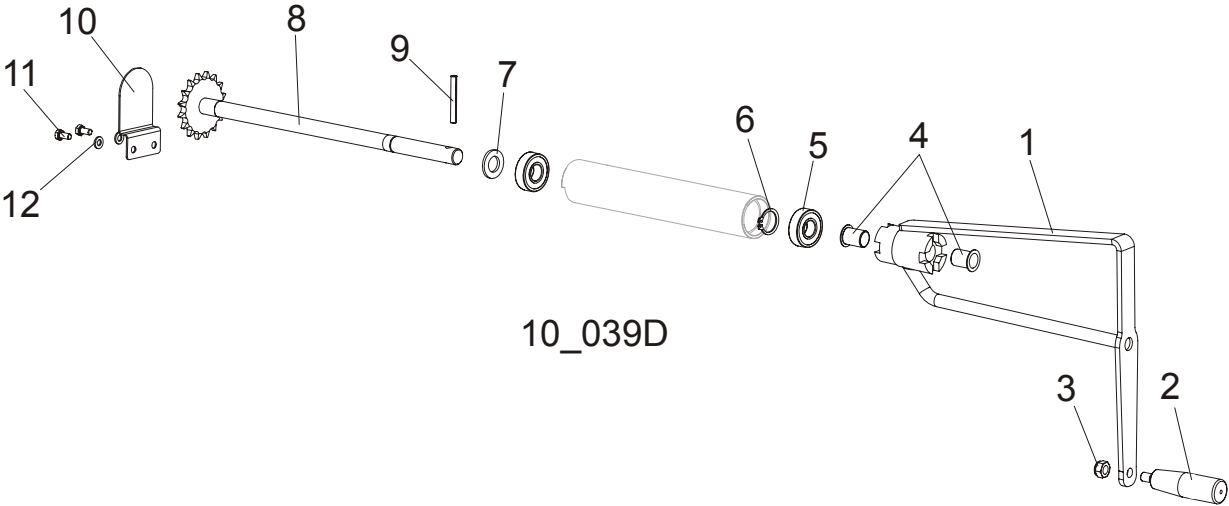

REF	DESCRIPTION (◆ Indicates Parts Available In Assemblies Only)	Part #	Qty.	
	<b>FEED CRANK ASSEMBLY LT10/MP100/HR110</b>	<b>508239</b>	1	
1	CRANK, WELDMENT LT105	508238-1	1	
2	KNOB, 12992M10 PLASTIC CRANK HANDLE	086338	1	
3	NUT, M10-8-B HEX NYLON ZINC LOCK	F81033-1	1	
4	BUSHING, GFM-1719-25	094142	2	
5	<b>BEARING, 6203-2RS</b>	086114	2	
6	<b>RING, Z 17 OUTSIDE RETAINING</b>	F81090-21	1	
7	<b>WASHER, 17 FLAT ZINC</b>	F81058-1	1	
8	<b>SHAFT W/SPROCKET LT10</b>	097242-1	1	
9	<b>PIN, 6X50 ZINC ROLL</b>	F81045-1	1	
10	<b>GUARD, UPPER LT10 SAW HEAD SPROCKET</b>	092567-1	1	
11	<b>BOLT, M6X12-8.8 HEX HEAD FULL THREAD ZINC</b>	F81001-7	2	
12	<b>WASHER, 6.4 FLAT ZINC</b>	F81053-1	2	

### 7.2 Up/Down Drive Sprocket Assembly

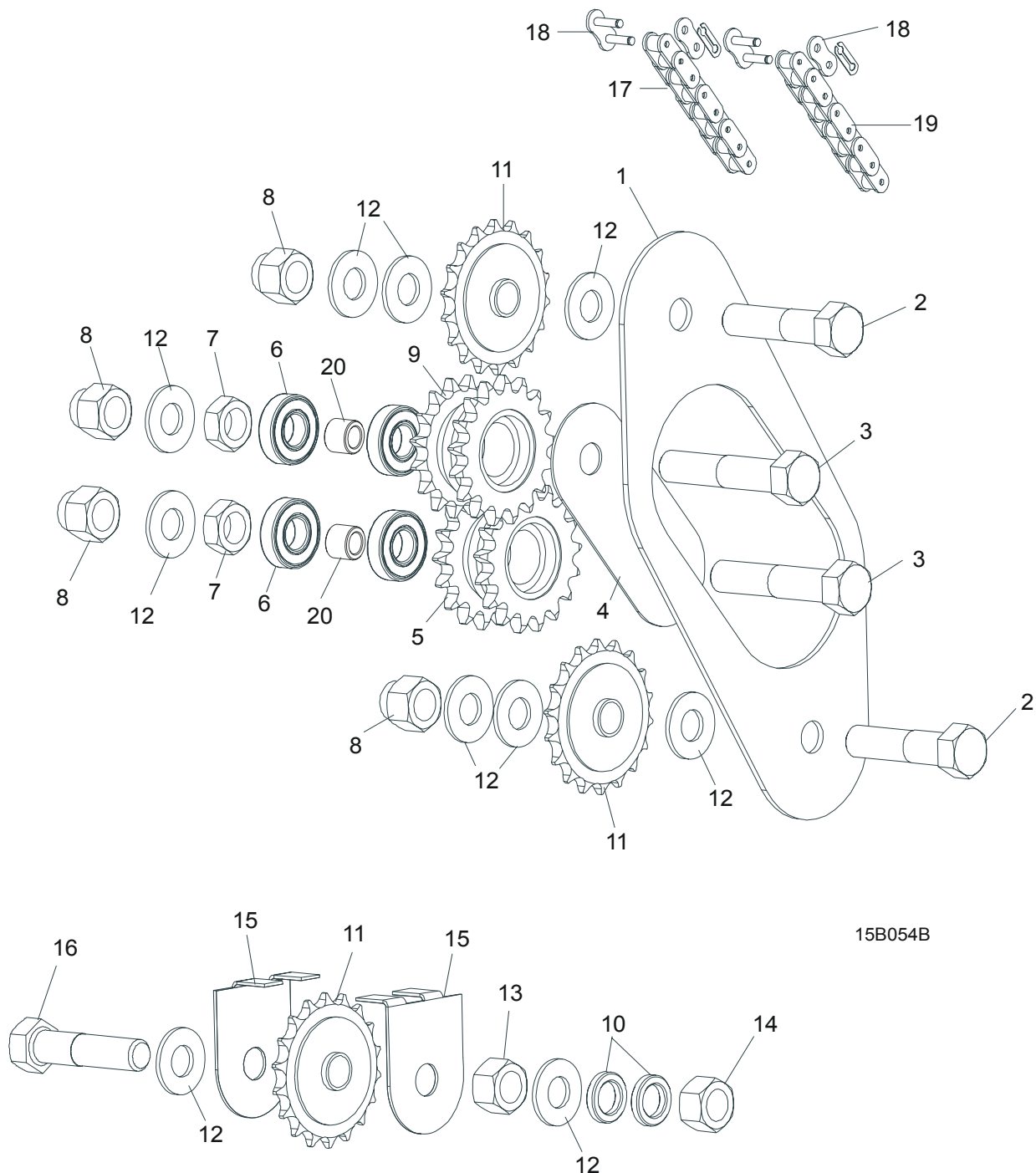

REF	DESCRIPTION (◆ Indicates Parts Available In Assemblies Only)	Part #	Qty.
1	GUARD, UP/DOWN CHAIN INTERNAL LT10	014907	1
2	BOLT, M16X65-8.8-B HEX HEAD FULL THREAD ZINC	F81006-1	2
3	BOLT, M16X80 8.8-B HEX HEAD FULL THREAD ZINC	F81006-11	2
4	PLATE, UP/DOWN DRIVE SPROCKET MOUNT PTD	087104-1	1

5	SPROCKET DUAL 17/17 PTD	086812-1	1	
6	BEARING, R-10	P04156	4	
7	NUT, M16 HEX THIN ZINC	F81036-4	2	
8	NUT, M16-8 HEX NYLON ZINC LOCK	F81036-2	4	
9	SPROCKET DUAL 16/17 PTD	086813-1	1	
10	WASHER, 41/64" X 1" X 3/16 SPACER	S12480	3	
11	SPROCKET, 17T G1#40-41 5/8" ID	P04333	3	
12	WASHER 17 FLAT ZINC	F81058-1	12	
13	NUT M16-5.8 HEX ZINC	F81036-1	1	
14	NUT, M16-8 HEX NYLON ZINC LOCK	F81036-2	1	
15	GUARD,LT10 UP/DOWN CHAIN SPROCKET	092566-1	2	
16	BOLT, M16X75-8.8-B HEX HEAD FULL THREAD ZINC	F81006-10	1	
17	CHAIN, #40 X 111 1/2"	014831	1	
18	LINK, #40 MASTER	P04200	2	
19	CHAIN, #40 X 15 1/2"	P12496	1	
20	BUSHING - ZINC	095938-1	2	

7.3 Slide Pads and Blade Height Scale Indicator

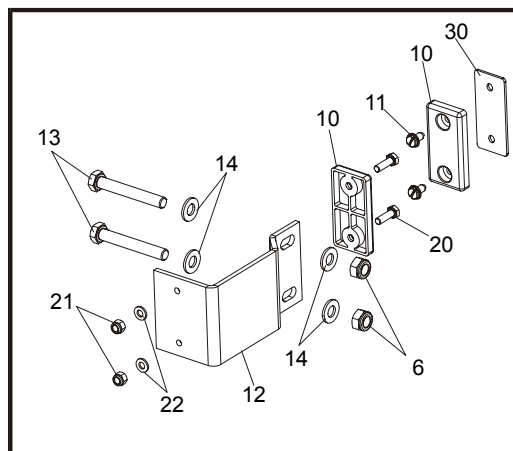
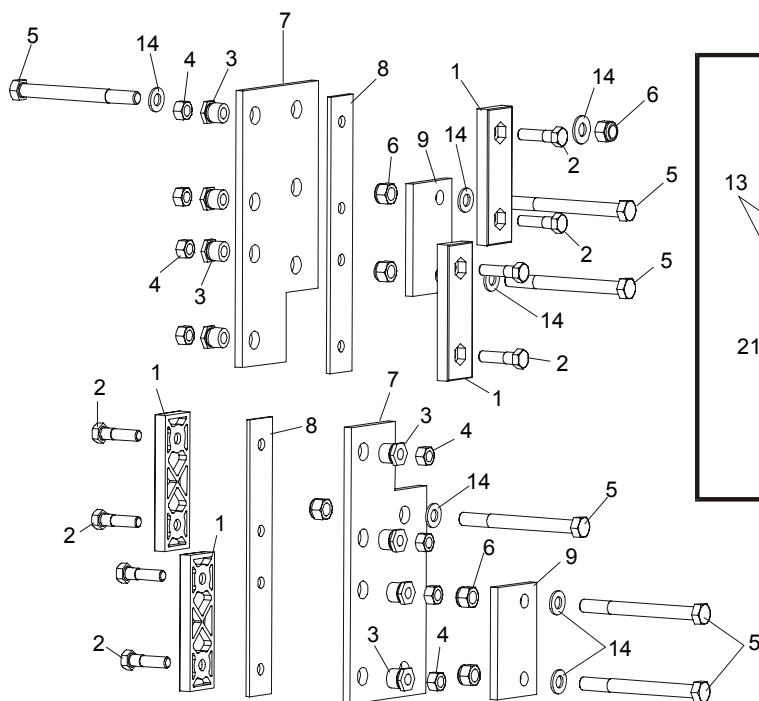
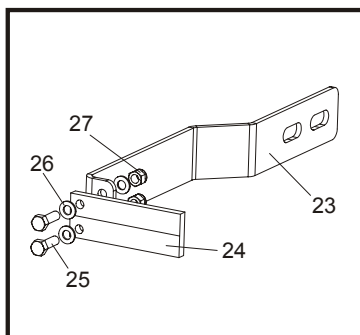
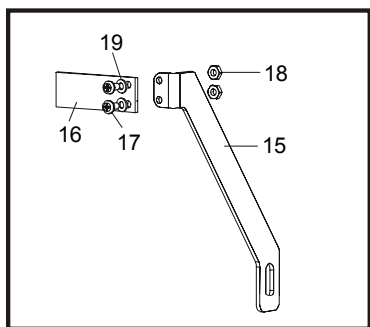

10\_041B

REF	DESCRIPTION (◆ Indicates Parts Available In Assemblies Only)	Part #	Qty.
1	PADS, UP/DOWN SLIDE	M04096	4
2	BOLT, M8X35 -8.8 HEX HEAD FULL THREAD ZINC	F81002-13	8
3	NUT, LT10 SLIDE PAD ADJUSTMENT ZINC-PLATED	086683-1	8
4	NUT, M8-8-B HEX NYLON ZINC LOCK	F81032-2	8
5	BOLT, M10X110 8.8 HEX HEAD ZINC	F81003-43	6
6	NUT, M10-8-B HEX NYLON ZINC LOCK	F81033-1	8
7	PLATE, LT10 SLIDE PAD MOUNT	086682-1	2
8	BACKING, MAST SLIDE PADS	014898-1	2
9	PLATE, SHORT SLIDE PAD MOUNT	085978-1	2
10	PAD, CATERPILLAR TRACK	P13576	2

11	BOLT, 1/4-20 X 1/2"SELF TAP HEX HEAD	F05015-1	2	
12	BRACKET, LT10MAST GUIDE IDLE SIDE PAINTED	087192-1	1	
13	BOLT, M10X70-8.8 HEX HEAD FULL THREAD ZINC	F81003-20	2	
14	WASHER, 10.5 FLAT ZINC	F81055-1	11	
15	BRACKET, LT10 BLADE HEIGHT SCALE MOUNT	092568-1	1	
16	INDICATOR, BLADE HEIGHT SCALE	094821	1	
17	BOLT, M4X16 5.8 HEX HEAD FULL THREAD ZINC	F81011-6	2	
18	NUT, M4-B HEX NYLON ZINC LOCK	F81029-1	2	
19	WASHER, 4.3-FLAT ZINC	F81051-2	2	
	DECAL, METRIC SCALE LT10	086142		
20	BOLT, M6X20-8.8 HEX HEAD FULL THREAD ZINC	F81001-2	2	
21	NUT, M6-8-B HEX NYLON ZINC LOCK	F81031-2	2	
22	WASHER, 6.4 FLAT ZINC	F81053-1	2	
	INDICATOR, BLADE HEIGHT SCALE COMPLETE (OPTION)	<b>097569</b>		
23	Base, Blade Height Indicator Painted	097568-1	1	
24	Indicator, Blade Height	094821	1	
25	Bolt, M5x16 -8.8 Hex Head Full Thread Zinc	F81000-20	2	
26	Washer, 5.3 Flat Zinc	F81052-1	4	
27	Nut, M5-8-Fe/Zn5 DIN 985	F81030-2	2	
28	Bolt, M8x12-8.8 Hex Head Full Thread Zinc	F81002-6	2	
29	Washer, 8,4 Flat Zinc	F81054-1	2	
30	WASHER, SLIDE PAD	101324-1	1	

**7.4 Blade Height Scale (Optional)**

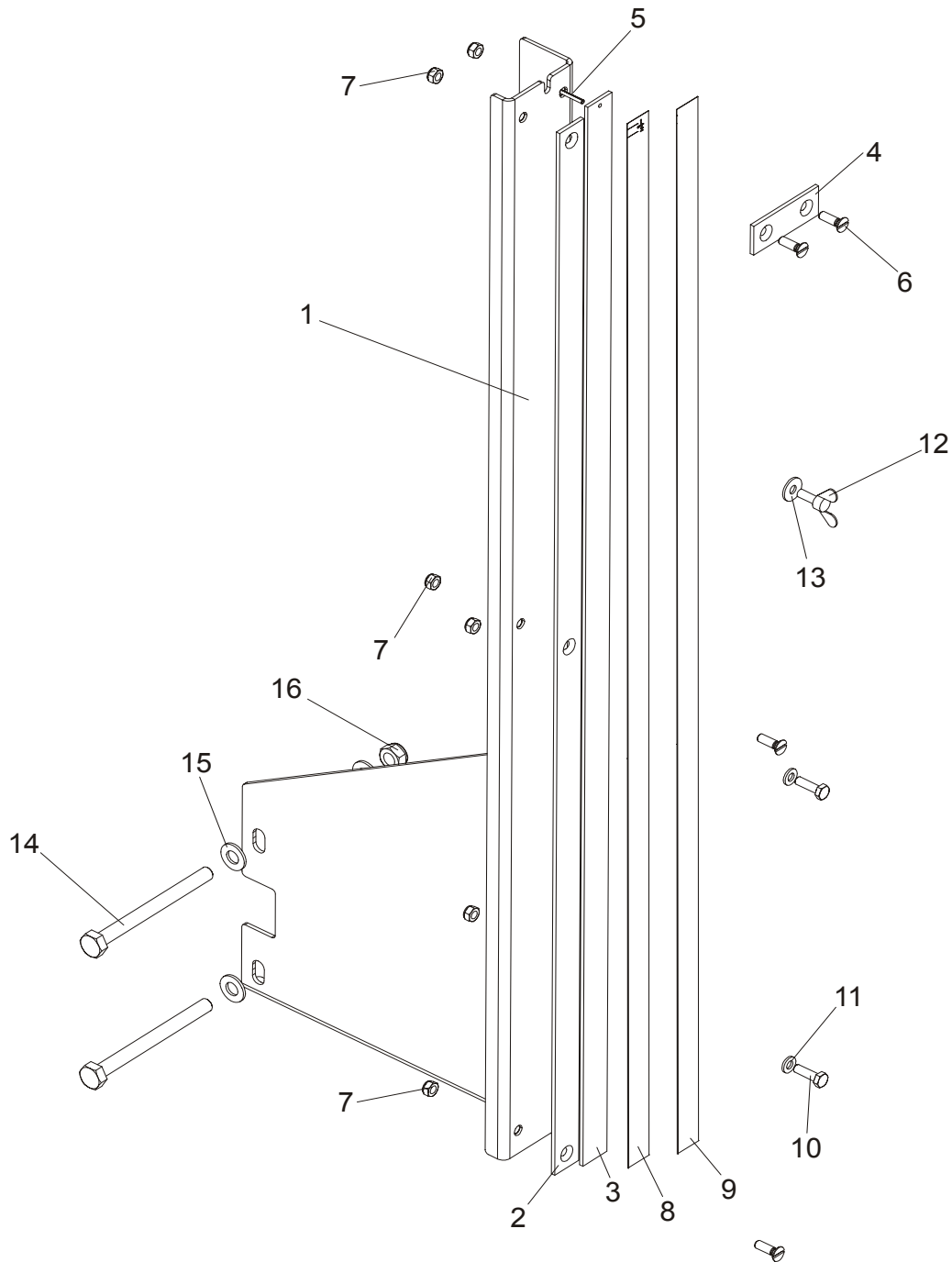

REF	DESCRIPTION (◆ Indicates Parts Available In Assemblies Only)	PART #	QTY.	
	<b>SCALE , BLADE HEIGHT COMPLETE</b>	095964	1	
1	Bcracket, Blade Height Scale LT10 Painted	095965-1	1	
2	Plate, Decal Mount	092750	1	
3	Plate, Inch Decal Mount	093133	1	

4	Bar, Scale Mount	093134	1	
5	Pin, 3x20 Zinc Roll	F81044-5	1	
6	Screw, M6x20 Slotted Countersunk Head Zinc	F81001-31	3	
7	Nut, Hex Nylon Zinc Lock	F81031-2	6	
8	Decal, LT10 0-80CM Centimeter Scale	091239	1	
9	Decal, 16-40mm Metric Decal, 45-63mm Metric	P12040-1 P12040-2	1	
10	Bolt, M6x20-8.8 Hex Head Full Thread Zinc	F81001-2	2	
11	Washer, 6.4 Flat Zinc	F81053-1	2	
12	Screw, M6x16 BN276 DIN 316 Thumb	F81001-16	1	
13	Washer, 6.5 Special Flat Zinc	F81053-11	1	
14	Bolt, M10x115-8.8 Hex Head Zinc	F81003-19	2	
15	Washer, 10.5 Flat Zinc	F81055-1	4	
16	Nut, M10-8-B Hex Nylon Zinc Lock	F81033-1	2	