

Wood-Mizer®

Parts Manual

LT15SA

rev. A1.00



Safety is our #1 concern! Read and understand all safety information and instructions before operating, setting up or maintaining this machine.

Form #795

Table of Contents

Section-Page

SECTION 1	GENERAL INFORMATION	1-1
1.1	How To Use The Parts List	1-1
1.2	Sample Assembly	1-1
SECTION 2	BED FRAME	2-1
2.1	Log Side Support Assembly	2-1
2.2	Bed Section Connecting Hardware	2-2
2.3	Stationary Leg Kit	2-3
2.4	Outrigger Leg Kit	2-4
2.5	Log Clamp Assembly	2-5
2.6	Auxiliary Bed Rail Assembly	2-6
2.7	Log Wedge, Loading Ramps & Cant Hook (Optional).....	2-7
2.8	Bed Extensions	2-8
2.9	"M" Type Bed Frame Section (LT15 Sawmills Only).....	2-9
2.10	"S" Type Frame Bed Section	2-9
2.11	Additional Bed Frame Section with Stationary Legs	2-10
2.12	Additional Bed Frame Section with Outrigger Legs	2-10
SECTION 3	LEG ASSEMBLIES	3-1
3.1	"S" Frame Legs	3-1
3.2	"M" Frame Legs	3-2
SECTION 4	BLADE GUIDE ROLLERS & ARM	4-1
4.1	Blade Guide Assembly, Idle Side.....	4-1
4.2	Blade Guide Assembly, Drive Side.....	4-3
4.3	Blade Guide Roller Guard	4-5
4.4	Blade Guide Arm w/Lever	4-6
SECTION 5	BLADE WHEELS & TENSIONER	5-1
5.1	Blade Wheel Assembly, Drive Side	5-1
5.2	Blade Wheel Assembly, Idle Side	5-2
5.3	Blade Tensioner Assembly	5-4
5.4	Motor	5-6
5.5	Power Cord Bracket	5-7
5.6	Blade brake	5-8

Table of Contents

Section-Page

SECTION 6 SAW HEAD

6-1

6.1	Blade Housing Cover	6-1
6.2	Water Lube Assembly	6-3
6.3	LT10 Saw Head Decals	6-4
6.4	Control Box	6-6

SECTION 7 FEED SYSTEM

7-1

7.1	Track Rail, Rollers & Travel Pins	7-1
7.2	Track Rail, Rollers & Travel Pins	7-3

SECTION 7 UP/DOWN SYSTEM

8-1

7.1	Up/Down Crank Assembly.....	8-1
7.2	Drill Bracket (Option)	8-2
7.3	Up/Down Drive Sprocket Assembly	8-3
7.4	Slide Pads	8-5
7.5	Mast Guide	8-6
7.6	Blade Height Scale Indicator	8-7
7.7	Blade Height Scale Bracket	8-8
7.8	LT10 Electric Up/Down System (Option)	8-10
7.9	Electric Up/Down Control Assembly (Option for CE Version)	8-11

SECTION 1 GENERAL INFORMATION

1.1 How To Use The Parts List

- Use the index above to locate the assembly that contains the part you need.
- Go to the appropriate section and locate the part in the illustration.
- Use the number pointing to the part to locate the correct part number and description in the table.
- Parts shown indented under another part are included with that part.
- Parts marked with a diamond (◆) are only available in the assembly listed above the part.

See the sample table below. Sample Part #A01111 includes part F02222-2 and subassembly A03333. Subassembly A03333 includes part S04444-4 and subassembly K05555. The diamond (◆) indicates that S04444-4 is not available except in subassembly A03333. Subassembly K05555 includes parts M06666 and F07777-77. The diamond (◆) indicates M06666 is not available except in subassembly K05555.

1.2 Sample Assembly				
REF.	DESCRIPTION (◆ Indicates Parts Available In Assemblies Only)	PART #	QTY	
	Sample Assembly, Complete (Includes All Indented Parts Below)	A01111	1	
1	Sample Part	F02222-22	1	
	Sample Subassembly (Includes All Indented Parts Below)	A03333	1	
2	Sample Part (◆ Indicates Part Is Only Available With A03333)	S04444-4	1	◆
	Sample Subassembly (Includes All Indented Parts Below)	K05555	1	
3	Sample Part (◆ Indicates Part Is Only Available With K05555)	M06666	2	◆
4	Sample Part	F07777-77	1	

To Order Parts:

- From Europe call our European Headquarters and Manufacturing Facility in Kolo, Poland at **+48-63-2626000**. From the continental U.S., call our toll-free Parts hotline at **1-800-525-8100**. Have your customer number, vehicle identification number, and part numbers ready when you call. From other international locations, contact the Wood-Mizer distributor in your area for parts.

Office Hours:

Country	Monday - Friday	Saturday	Sunday
Poland	7-15	Closed	Closed
US	8 a.m.- 5 p.m.	8 a.m.- 12 p.m.	Closed



CAUTION! It is strongly recommended that only original spare parts be used.

SECTION 2 BED FRAME

2.1 Log Side Support Assembly

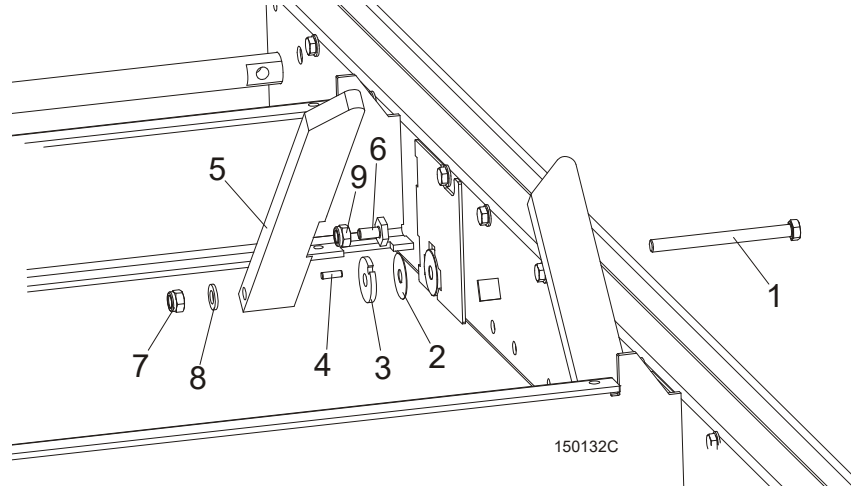

REF.	DESCRIPTION (◆ Indicates Parts Available In Assemblies Only)	PART #	QTY
1	BOLT, M12X140-8.8 HEX HEAD ZINC	F81004-35	1
2	WASHER, 33/64 X 1 3/4 X 1/32" NYLON	014972	1
3	WASHER, LT15 THICK SPACER	085981-1	1
	SUPPORT, LT15 LOG SIDE COMPLETE PAINTED	085982-1	1
4	PIN, H 6n6x20 60HRC ROLL	100472	1
5	PLATE, LT15 LOG SIDE SUPPORT	085980	1
6	BOLT, M10x20 SPECIAL	100076-1	1
7	NUT, M12-8 HEX NYLON ZINC LOCK	F81034-2	1
8	WASHER, 13 FLAT ZINC	F81056-1	1
9	NUT, M10-8-B HEX ZINC	F81033-3	1

2 BED FRAME

Bed Section Connecting Hardware

2.2 Bed Section Connecting Hardware

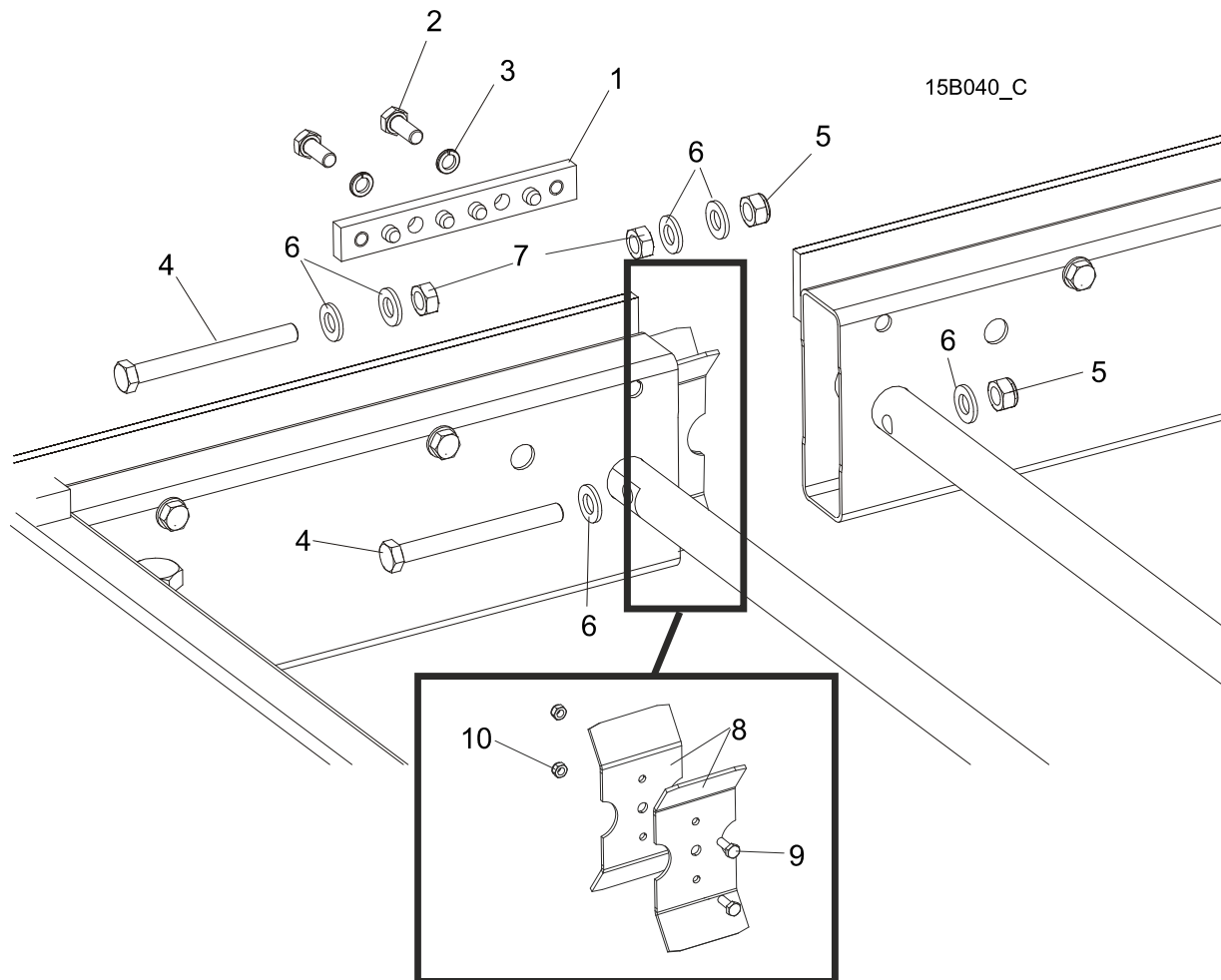

REF.	DESCRIPTION (◆ Indicates Parts Available In Assemblies Only)	PART #	QTY
1	SPLICE, TRACK RAIL PINNED	086659-1	1
2	BOLT, M10X25-5.8 HEX HEAD FULL THREAD ZINC	F81003-11	2
3	WASHER, 10.2 SPLIT LOCK ZINC	F81055-2	2
4	BOLT, M12X120 8.8 HEX HEAD ZINC	F81004-38	2
5	NUT, M12-8 HEX NYLON ZINC LOCK	F81034-2	2
6	WASHER, 13 FLAT ZINC	F81056-1	6
7	NUT, M12-8-B HEX ZINC	F81034-1	2
	CONNECTOR, LT15 BED SECTION	506288 ¹	2
8	PLATE, LT15 BED SECTION CONNECTOR	506287-1	1
9	BOLT, M6 x 16 8.8 HEX HEAD FULL THREAD ZINC	F81001-15	2
10	NUT, M6-8-B HEX NYLON ZINC LOCK	F81031-2	2

¹ 2 pieces for each bed section

2.3 Stationary Leg Kit

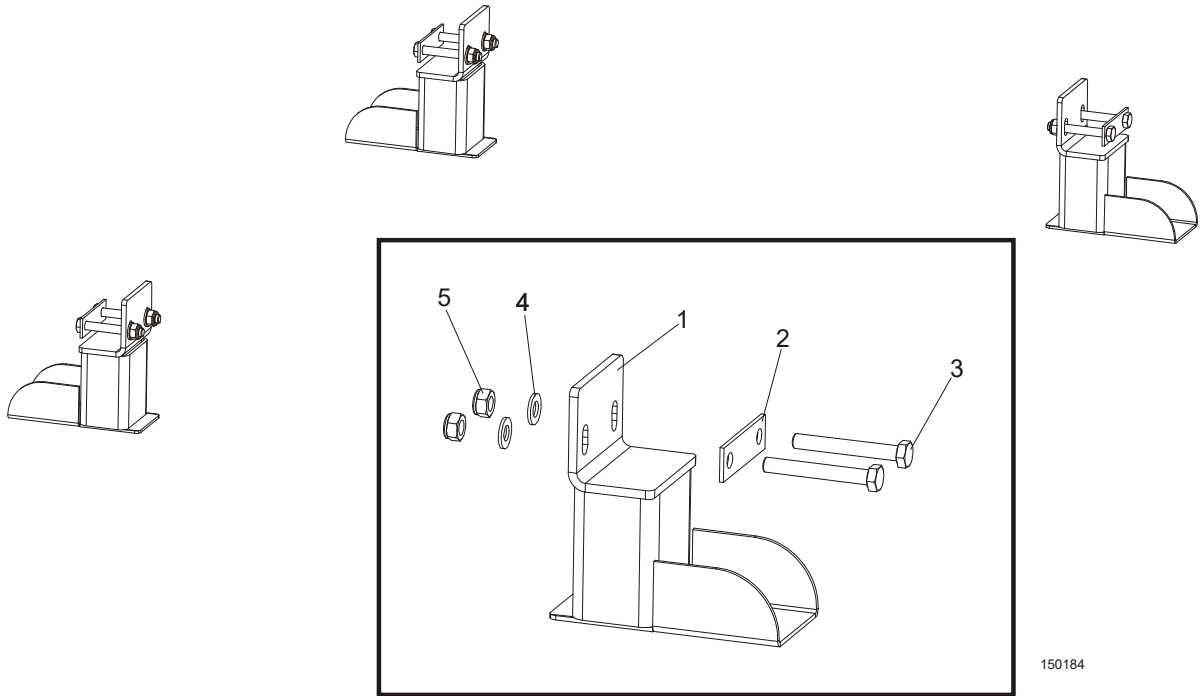

REF.	DESCRIPTION (◆ Indicates Parts Available In Assemblies Only)	PART #	QTY
	STATIONARY LEG KIT FOR 1950 MM BED SECTION	100069	1
1	Leg, LT15 Stationary Bed	100064-1	4
2	Washer, LT15 Bed Leg	085994-1	4
3	Bolt, M10x75-8.8 Hex Head Zinc	F81003-15	8
4	Washer, 10.5 Flat Zinc	F81055-1	8
5	Nut, M10-8-B Hex Nylon Zinc Lock	F81033-1	8
	STATIONARY LEG KIT FOR 2700 MM BED SECTION	100070	1
1	Leg, LT15 Stationary Bed	100064-1	6
2	Washer, LT15 Bed Leg	085994-1	6
3	Bolt, M10x75-8.8 Hex Head Zinc	F81003-15	12
4	Washer, 10.5 Flat Zinc	F81055-1	12
5	Nut, M10-8-B Hex Nylon Zinc Lock	F81033-1	12

2.4 Outrigger Leg Kit

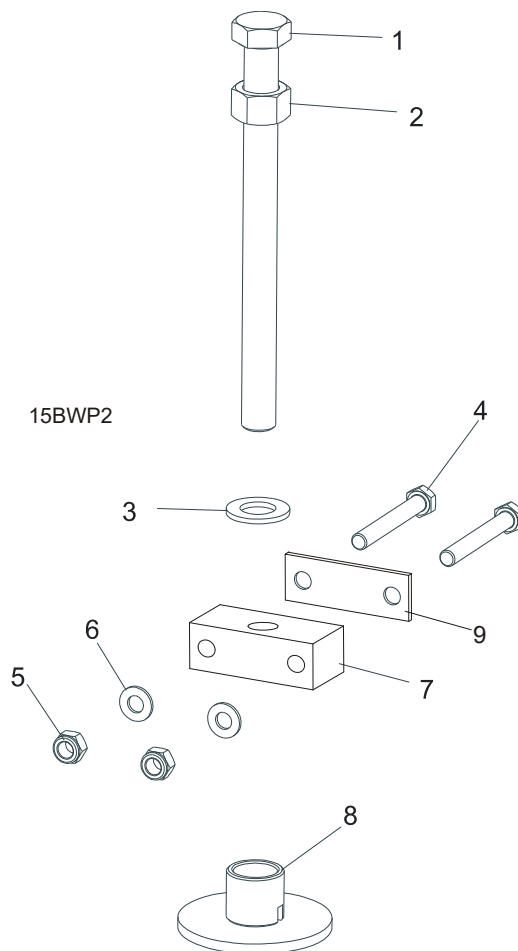

REF.	DESCRIPTION (◆ Indicates Parts Available In Assemblies Only)	PART #	QTY
	OUTRIGGER LEG KIT FOR 1950 MM BED SECTION (LT15S3)	095232 ¹	3
	OUTRIGGER LEG KIT FOR 2700 MM BED SECTION (LT15M2)	095234 ²	2
1	Bolt, M20x240-8.8 Hex Head Full Thread Zinc	F81007-1	1
2	Nut, M20-8 Hex Zinc	F81037-1	1
3	Washer, 21 Flat Zinc	F81059-2	1
4	Bolt, M10x120-8.8 Hex Head Zinc	F81003-58	2
5	Nut, M10-8-B Hex Nylon Zinc Lock	F81033-1	2
6	Washer, 10.5 Flat Zinc	F81055-1	2
7	Block, LT15 Leg Mount	095745-1	1
8	Plate Weldment, LT15 Leg Foot Zinc-plated	087771-1	1
9	Washer, LT15 Bed	085994-1	1

¹ Four legs are mounted to each 1950-mm long bed section.

² Six legs are mounted to each 2700-mm long bed section.

2.5 Log Clamp Assembly

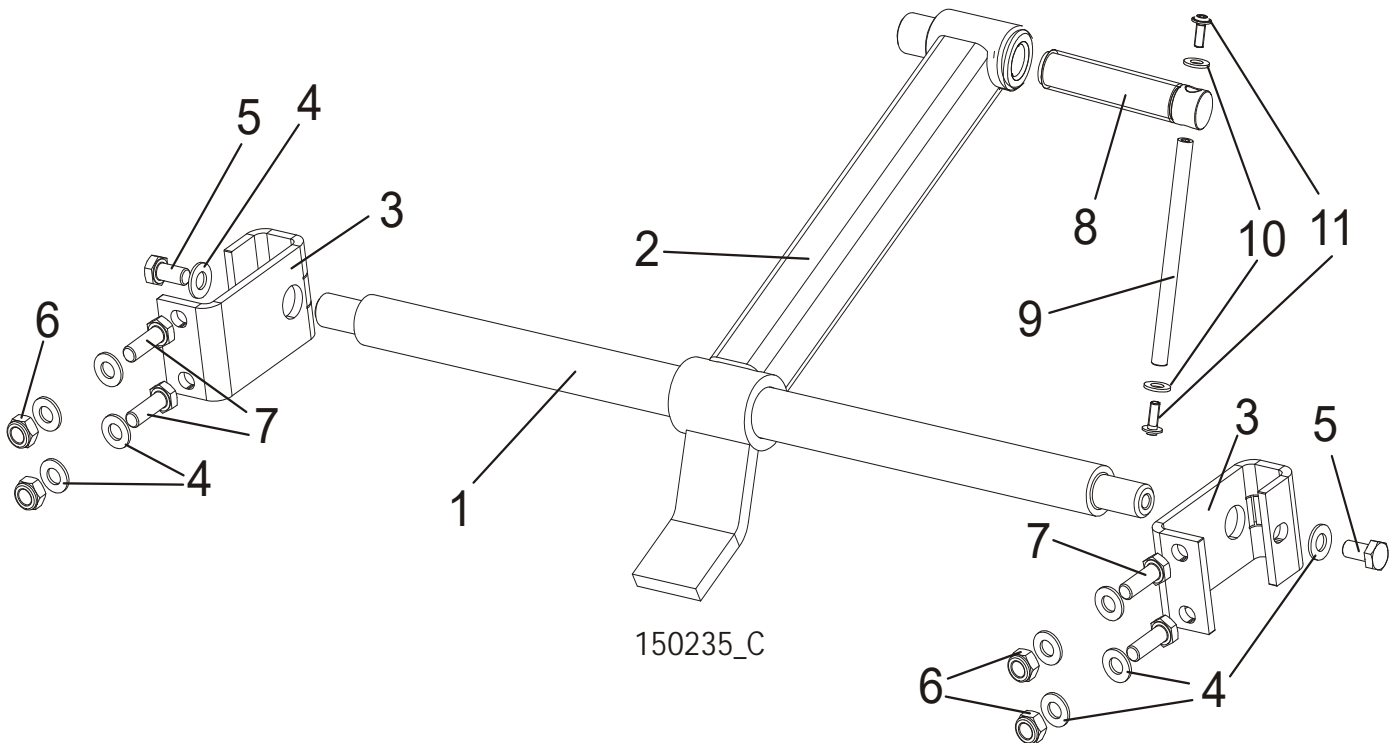

REF.	DESCRIPTION (◆ Indicates Parts Available In Assemblies Only)	PART #	QTY
	LOG CLAMP ASSEMBLY, LT15/15 COMPLETE	507565	2
1	ROD MAIN CLAMP	500343-1	1
2	CLAMP ARM	507566-1	1
3	BRACKET, LOG CLAMP MOUNT ZINC	506535-1	2
4	WASHER, 10.5 FLAT ZINC	F81055-1	10
5	BOLT, M10x20-5.8 HEX HEAD FULL THREAD ZINC	F81003-1	2
6	NUT, M10-8-B NYLON HEX ZINC LOCK	F81033-1	4
7	BOLT, M10X30-5.8 HEX HEAD FULL THREAD	F81003-2	4
	CLAMP BOLT - COMPLETE	507563	1
8	CLAMP BOLT	507463	1
	ROD - COMPLETE	511924	1
9	ROD, ZINC-PLATED	511923-1	1
10	WASHER, 8.4 FLAT ZINC	F81054-1	2
11	BOLT, M6x16 BN 11252 "BOSSARD"	F81001-24	2

2.6 Auxiliary Bed Rail Assembly

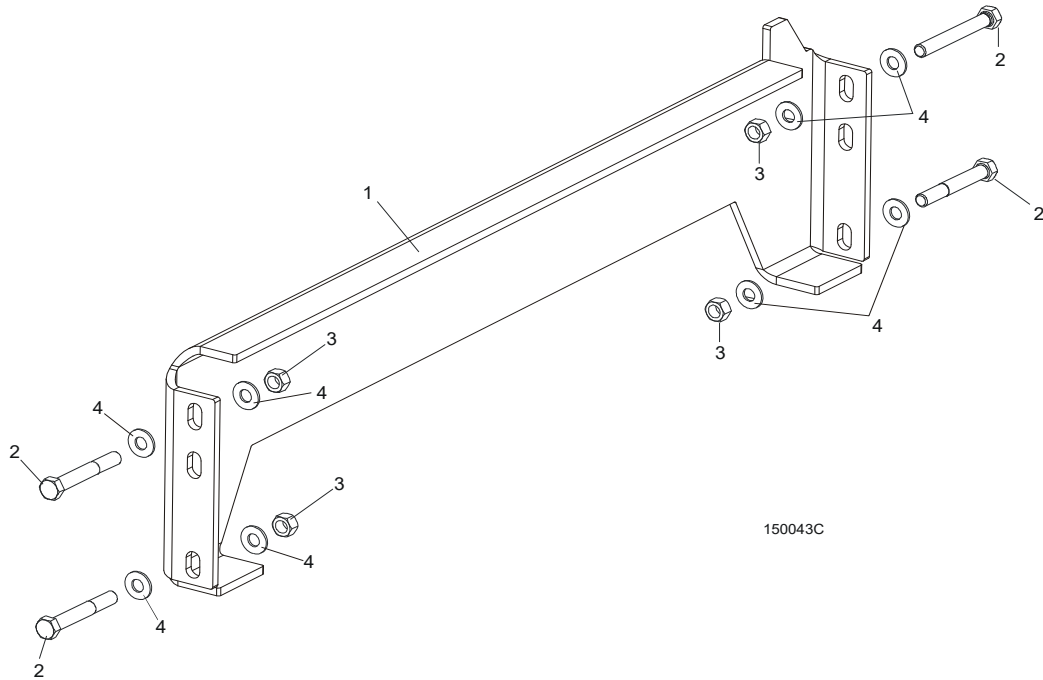

REF.	DESCRIPTION (◆ Indicates Parts Available In Assemblies Only)	PART #	QTY	
1	RAIL WELDMENT, LT15 AUXILIARY BED	095490-1	1	◆
2	BOLT M10X75-8.8 HEX HEAD ZINC	F81003-15	4	
3	NUT, M10-8-B HEX NYLON ZINC LOCK	F81033-1	4	
4	WASHER 10.5 ZINC FLAT	F81055-1	8	

2.7 Log Wedge, Loading Ramps & Cant Hook (Optional)

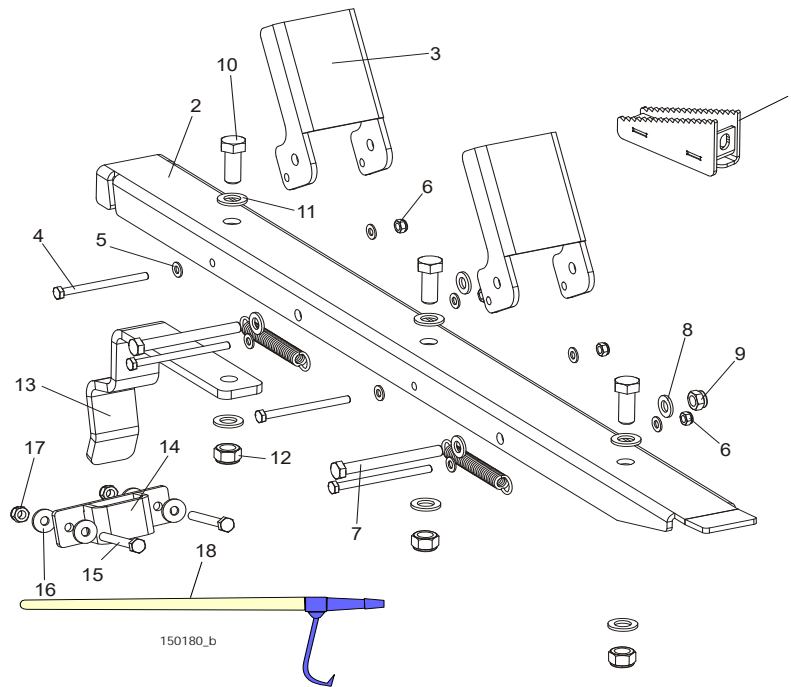

REF.	DESCRIPTION (◆ Indicates Parts Available In Assemblies Only)	PART #	QTY
	ACCESSORIES, LT15 SAWMILL	085997	1
1	Wedge Weldment, Log Taper (included in 015811 kit)	510720-1	1
	Wedge Weldment, Log Taper, for Bed Rail with Cover	515360-1	1
	Ramp Assembly, Log Loading, LT15 compl.	097977	2
	Ramp Assembly	097483	1
2	Ramp Weldment, Zinc-plated	097481-1	1
3	Bracket, Log Loading Stop Zinc-plated	097482-1	2
4	Bolt M8x100 -8.8 Hex Head Zinc	F81002-23	4
5	Washer, 8.4 Flat Zinc	F81054-1	8
6	Nut, M8-8-B Hex Nylon Zinc Lock	F81032-2	4
7	Bolt, M12x115-8.8 Hex Head Zinc	F81004-33	2
8	Washer, 13 Flat Zinc	F81056-1	2
9	Nut, M12-8 Hex Nylon Zinc Lock	F81034-2	2
10	Bolt, M16x40-8.8 Hex Head Full Thread Zinc	F81006-13	2
11	Washer, 17 Flat Zinc	F81058-1	4
12	Nut, M16-8 Hex Nylon Zinc Lock	F81036-2	2
13	Bracket, LT15 Ramp Zinc-plated	097976-1	1
	Bracket, LT15 Ramp - Complete	507518	1
14	Bracket Weldment, LT15 Ramp	507517-1	1
15	Bolt, M10x75-8.8 Hex Head Zinc	F81003-15	2
16	Washer, 10.5 Special Flat Zinc	F81055-6	4
17	Nut, M10-8-B Hex Nylon Zinc Lock	F81033-1	2
18	Cant Hook (included in 015811 kit)	CH	1

2.8 Bed Extensions

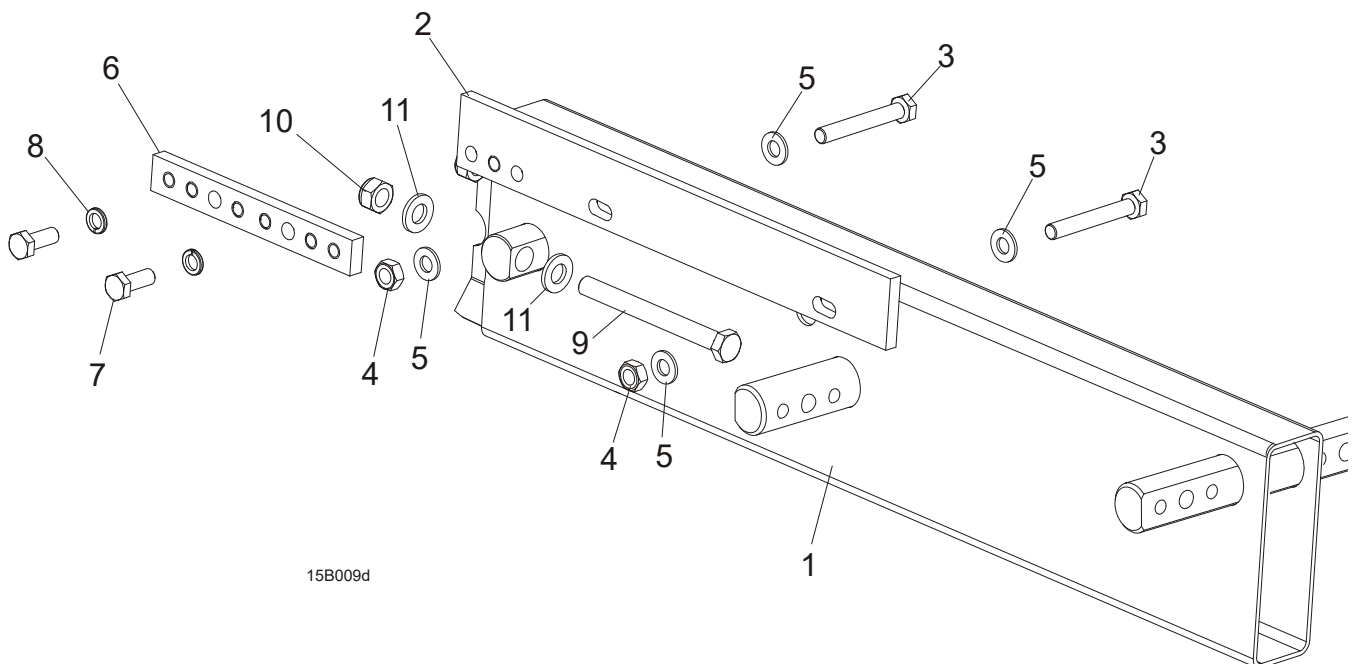

REF.	DESCRIPTION (◆ Indicates Parts Available In Assemblies Only)	PART #	QTY
	EXTENSION, BED FRONT - COMPLETE	500845	1
	EXTENSION, BED REAR - COMPLETE	500843	1
1	Tube, LT15 GP Bed Extension	500844-1	1
2	Rail, Bed Extension Track Zinc-plated	094250-1	1
3	Bolt, M10 x 75-8.8 Hex Head Zinc	F81003-15	2
4	Nut, M10-8-B Hex Nylon Zinc Lock	F81033-1	2
5	Washer, 10.5 Flat Zinc	F81055-1	4
6	Splice, Track Rail Pinned	086659-1	1
7	Bolt, M10x30-8.8 Hex Head Full Thread Zinc	F81003-2	2
8	Washer, 10.2 Split Lock Zinc	F81055-2	2
9	Bolt, M12 x 120-8.8 Hex Head Zinc	F81004-38	2
10	Nut, M12-8 Hex Nylon Zinc Lock	F81034-2	2
11	Washer, 13 Flat Zinc	F81056-1	4

2.9 "M" Type Bed Frame Section (LT15 Sawmills Only)

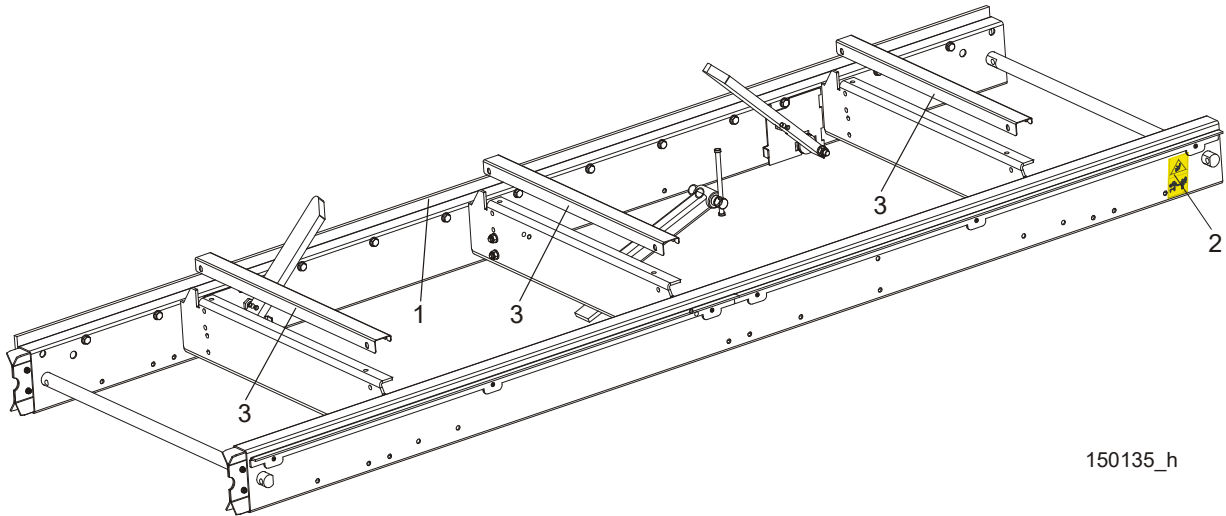

REF.	DESCRIPTION (◆ Indicates Parts Available In Assemblies Only)	PART #	QTY
	LT15 BED SECTION ASSEMBLY - LONG	094697	
1	Bar, LT15 2700 Track Zinc-plated	094696-1	1
2	DECAL, KEEP AWAY DANGER, PICTOGRAM	099221	1
3	COVER, BED RAIL LT15/15	509300 ¹	3

¹ Option

2.10 "S" Type Frame Bed Section

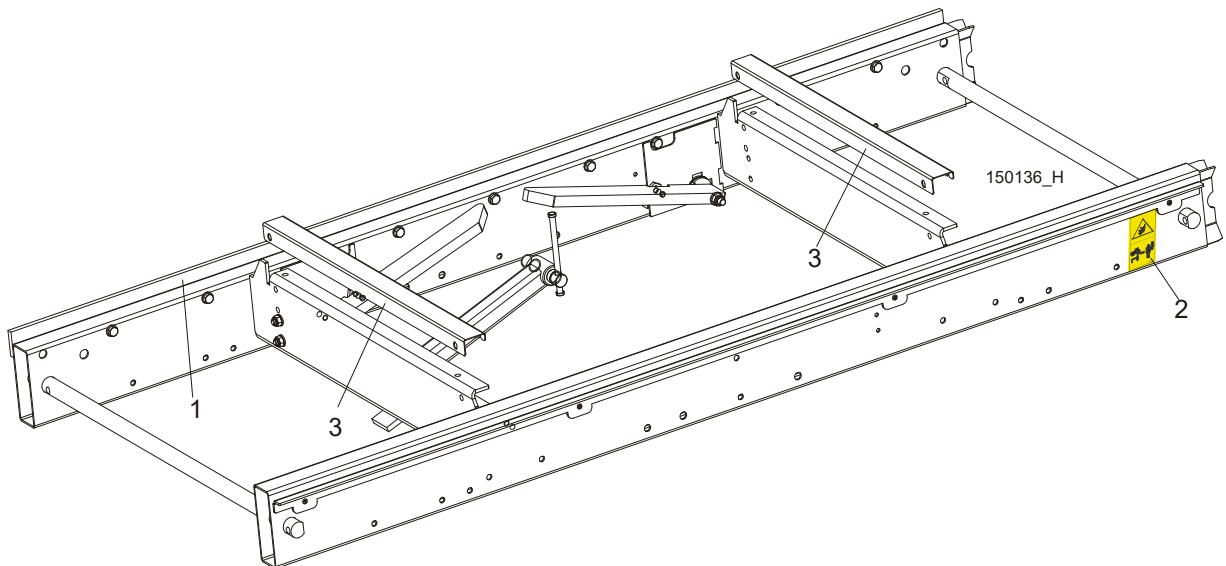

REF.	DESCRIPTION (◆ Indicates Parts Available In Assemblies Only)	PART #	QTY
	LT15 BED SECTION ASSEMBLY - SHORT	094514	
1	Bar, LT15 1950 Track, Zinc-plated	094427-1	1
2	DECAL, KEEP AWAY DANGER, PICTOGRAM	099221	1
3	COVER, BED RAIL LT15/15	509300 ¹	2

¹ Option

2.11 Additional Bed Frame Section with Stationary Legs

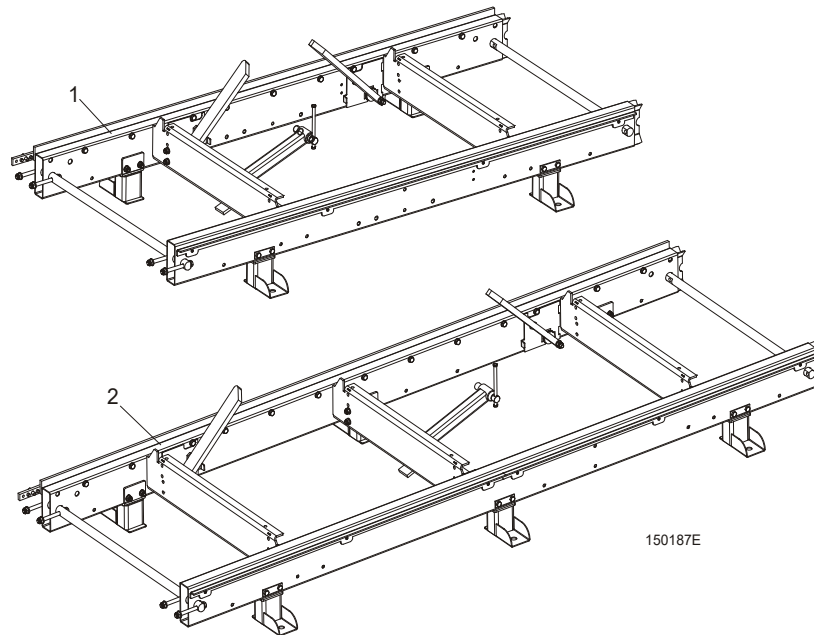

REF.	DESCRIPTION (◆ Indicates Parts Available In Assemblies Only)	PART #	QTY	
1	BED SECTION, LT15 1950 W/STATIONARY LEGS	100341-S	1	
2	BED SECTION, LT15 2700 W/STATIONARY LEGS (LT15 Sawmill only)	100342-S	1	

2.12 Additional Bed Frame Section with Outrigger Legs

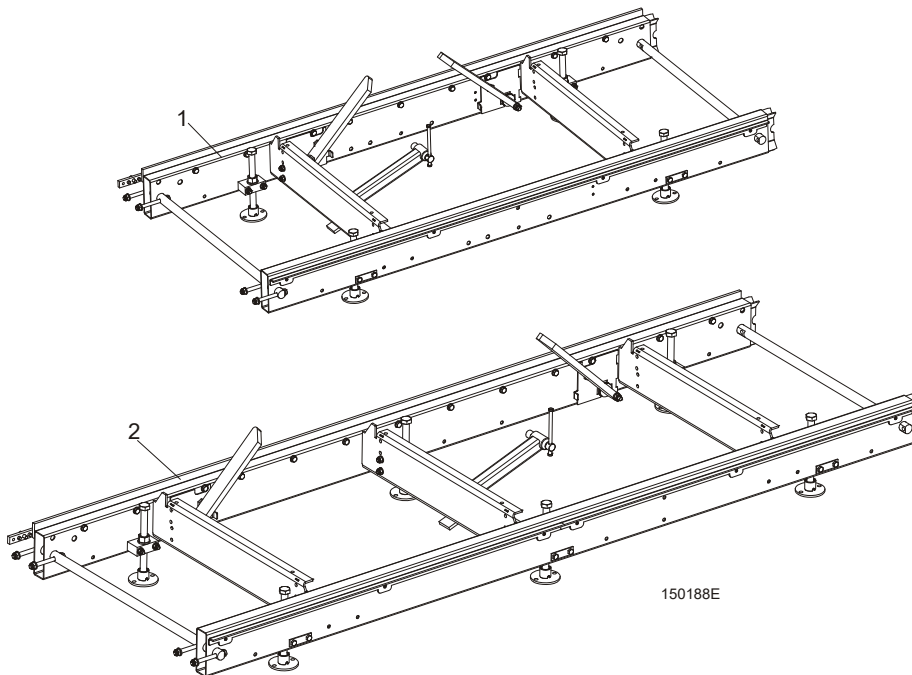

REF.	DESCRIPTION (◆ Indicates Parts Available In Assemblies Only)	PART #	QTY	
1	BED SECTION, LT15 1950 W/OUTRIGGER LEGS	095082-S	1	
2	BED SECTION, LT15 2700 W/OUTRIGGER LEGS (LT15 Sawmill only)	095083-S	1	

SECTION 3 LEG ASSEMBLIES

3.1 "S" Frame Legs

526815_001_B
 526815_MANUAL

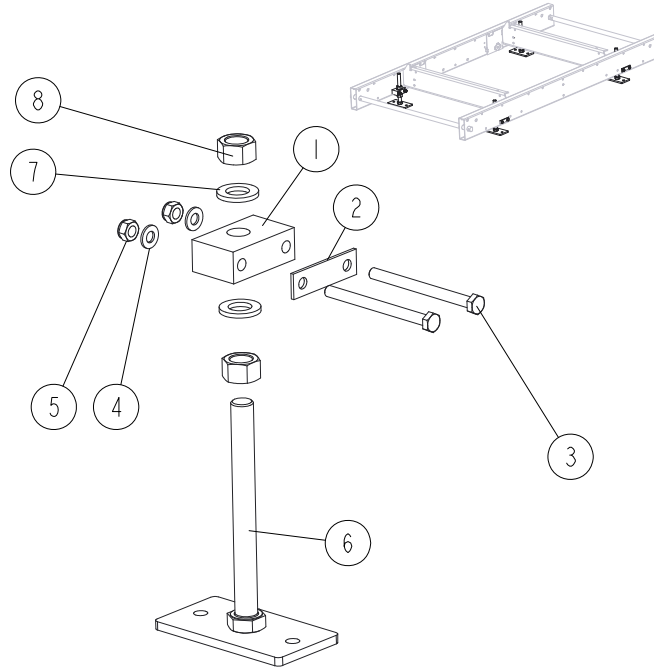

REF.	DESCRIPTION (* Indicates Parts Available in Assemblies Only)	PART NO.	QTY
-	LEG KIT, LT15WIDE - FRAME 1950 ADJUSTABLE	526815	1
1	BLOCK, LT15 LEG MOUNT	529838-1	4
2	WASHER, LT15 BED LEG	085994-1	4
3	BOLT, M10X120 8.8 HEX HEAD ZINC	F81003-58	8
4	WASHER, 10.5 FLAT ZINC	F81055-1	8
5	NUT, M10-8-B HEX NYLON ZINC LOCK	F81033-1	8
6	LEG WELDMENT, LT15W BED ZINC-PLATED	526820-1	4
7	WASHER, 21 FLAT ZINC	F81059-2	4
8	NUT, M20-8 HEX ZINC	F81037-1	4

3 LEG ASSEMBLIES

"M" Frame Legs

3.2 "M" Frame Legs

526816_001_B
526816_MANUAL

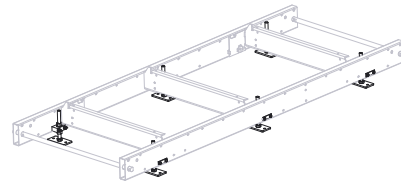
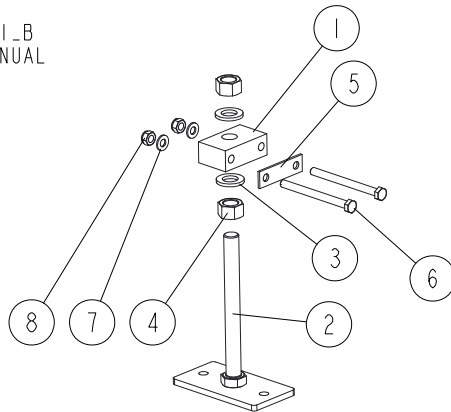

REF.	DESCRIPTION (* Indicates Parts Available in Assemblies Only)	PART NO.	QTY
-	LEG KIT, LT15WIDE-FRAME 2700 ADJUSTABLE	526816	1
1	BLOCK, LT15 LEG MOUNT	529838-1	6
2	LEG WELDMENT, LT15W BED ZINC-PLATED	526820-1	6
3	WASHER, 21 FLAT ZINC	F81059-2	6
4	NUT, M20-8 HEX ZINC	F81037-1	6
5	WASHER, LT15 BED LEG	085994-1	6
6	BOLT, M10X120 8.8 HEX HEAD ZINC	F81003-58	12
7	WASHER, 10.5 FLAT ZINC	F81055-1	12
8	NUT, M10-8-B HEX NYLON ZINC LOCK	F81033-1	12

SECTION 4 BLADE GUIDE ROLLERS & ARM

4.1 Blade Guide Assembly, Idle Side

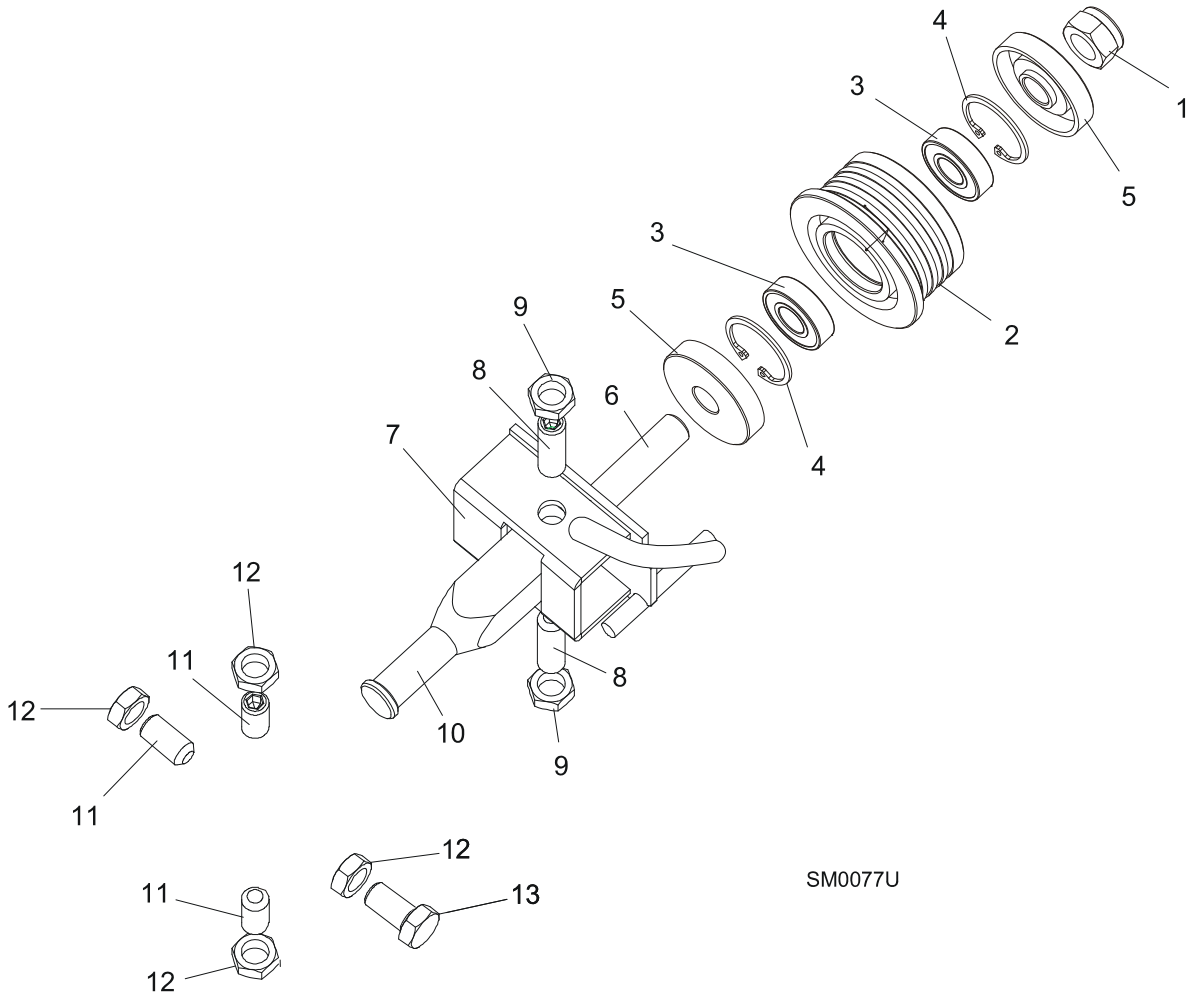

REF	DESCRIPTION (◆ Indicates Parts Available In Assemblies Only)	Part #	Qty.	
	BLADE GUIDE ASSEMBLY, IDLE SIDE	094683	1	
	Roller Assembly, Standard Blade Guide	087887	1	
1	Nut, M12-8 Hex Nylon Lock	F81034-2	1	
2	Roller, Narrow Blade Guide	087889	1	◆
3	Bearing, 6001 2RSR FAG	087893	2	
4	Ring, W28 Inside Retaining	F81090-9	1	
5	Washer, Zinc-plated Spacer	087891-1	2	
6	Shaft, Standard Blade Guide Roller Zinc	087763-1	1	
7	Bracket Weldment, Idle Side Blade Guide Painted	094681-1	1	
8	Screw, M10x1x40 DIN 913 A2-70 Stainless Steel Set	F81015-2	2	
9	Nut, M10x1-04-ST-A2 ISO 8675 Thin	F81033-10	2	
10	Shaft, Zinc-plated Blade Guide Mount	088255-1	1	
11	SCREW, M10X1X25 DIN 913 STAINLESS STEEL SET	F81015-4	4	

4

BLADE GUIDE ROLLERS & ARM

Blade Guide Assembly, Idle Side

12	NUT, M10x1-04-ST-A2 ISO 8675 THIN	F81033-10	4	
----	-----------------------------------	-----------	---	--

4.2 Blade Guide Assembly, Drive Side

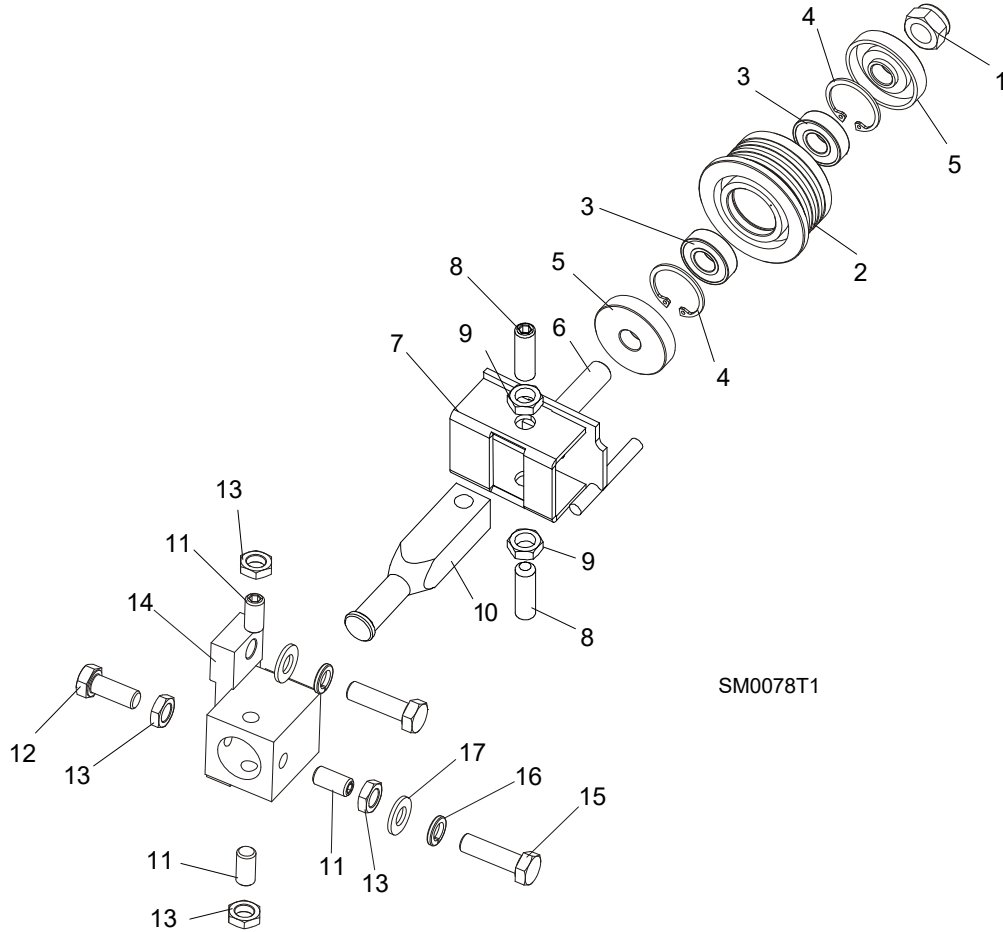

SM0078T1

REF	DESCRIPTION (◆ Indicates Parts Available In Assemblies Only)	Part #	Qty.	
	BLADE GUIDE ASSEMBLY DRIVE SIDE	094682	1	
	Roller Assembly, Standard Blade Guide	087887	1	
1	Nut, M12-8 Hex Nylon Lock Nut	F81034-2	1	
2	Roller, Narrow Blade Guide	087889	1	◆
3	Bearing, 6001 2RSR FAG	087893	2	
4	Ring, W28 Inside Retaining	F81090-9	1	
5	Washer, Zinc-plated Spacer	087891-1	2	
6	Shaft, Standard Blade Guide Roller Zinc	087763-1	1	
7	Bracket Weldment, Blade Guide Painted	094679-1	1	
	Screw Kit, Blade Guide Adjustment w/Nuts (for two blade guide assemblies)	K09942	1	
8	Screw, M10x1x40 DIN 913 A2-70 Stainless Steel Set	F81015-2	2	
9	Nut, M10x1-04-ST-A2 ISO 8675 THIN	F81033-10	2	
10	Shaft, Zinc-plated Blade Guide Mount	088255-1	1	
11	SCREW, M10X1X25 DIN 913 SET STAINLESS STEEL	F81015-4	3	
12	BOLT, M10X1X25 DIN 933 STAINLESS STEEL	F81003-28	1	

4**BLADE GUIDE ROLLERS & ARM***Blade Guide Assembly, Drive Side*

13	NUT, M10x1-04-ST-A2 ISO 8675 THIN	F81033-10	4	
14	TUBE, BLADE GUIDE MOUNT	087744	1	
15	BOLT, M10X35-8.8 HEX HEAD FULL THREAD ZINC	F81003-17	2	
16	WASHER, 10.2 SPLIT LOCK ZINC	F81055-2	2	
17	WASHER, 10.5 FLAT ZINC	F81055-1	2	

4.3 Blade Guide Roller Guard

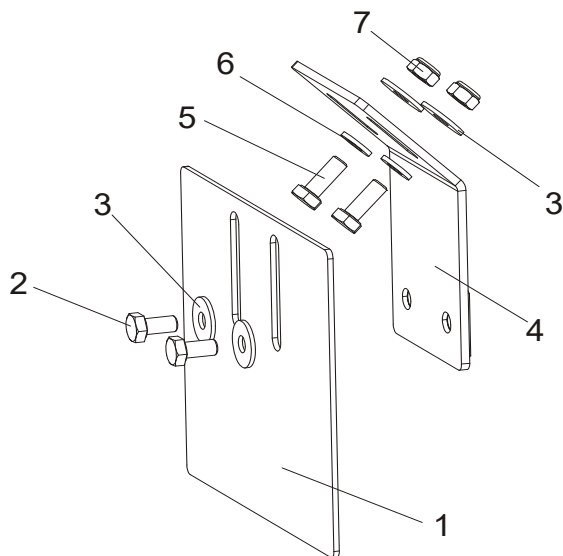

REF	DESCRIPTION (◆ Indicates Parts Available In Assemblies Only)	Part #	Qty
1	GUARD, BLADE GUIDE ROLLER PAINTED	092379-1	1
2	BOLT, M6X12-8.8 HEX HEAD FULL THREAD ZINC	F81001-7	2
3	WASHER, 6,5 SPECIAL FLAT ZINC	F81053-11	4
4	BRACKET, ROLLER GUARD MOUNT PAINTED	092378-1	1
5	SCREW, M6X16 8.8 HEX HEAD FULL THREAD ZINC	F81001-15	2
6	WASHER, 6,4 FLAT ZINC	F81053-1	2
7	NUT, M6-8-B HEX NYLON ZINC LOCK	F81031-2	2

4.4 Blade Guide Arm w/Lever

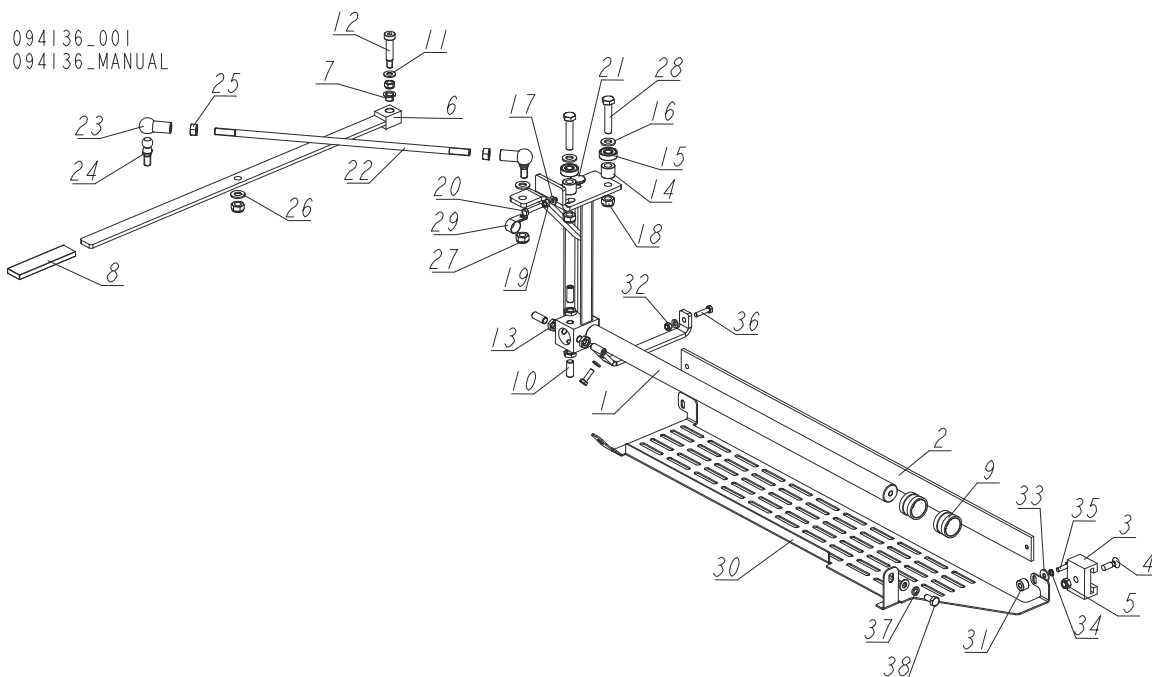

REF.	DESCRIPTION (◆ Indicates Parts Available In Assemblies Only)	PART #	QTY
-	BLADE GUIDE ARM W/LEVER - COMPLETE	094136	1
1	ARM WELDMENT, BLADE GUIDE	094138-1	1
2	BAR, BLADE GUARD	088306	1
3	GUIDE, BLADE GUARD	088305	1
4	SCREW, M8X25 CROSS RECESSED COUNTERSUNK HEAD ZINC	F81002-51	1
5	NUT, M8-8-B HEX NYLON ZINC LOCK	F81032-2	2
-	LEVER ASSEMBLY, BLADE GUIDE ARM ADJUSTMENT	093812	1
6	LEVER, BLADE GUIDE ARM ADJUSTMENT	093813-1	1
7	BEARING, TUF1 10.090 (CX)	099074	2
8	SLEEVE, VINYL GUARD	086875	1
9	BUSHING, BLADE GUIDE	086684	2
10	SCREW, M10X1X25 DIN 913 STAINLESS STEEL SET	F81015-4	4
11	WASHER, 8.4 FLAT ZINC	F81054-1	2
12	BOLT, 10/M8X35 12.9 ISO7379 SHOULDER	F81003-63	1
13	NUT, M10X1-04-ST-A2E ISO8675 THIN	F81033-10	4
14	BUSHING, 11/20-17 ZINC-PLATED	094255-1	2
15	BEARING, 6000.2RSR	087471	2
16	WASHER, 10.5 FLAT ZINC	F81055-1	4
17	WASHER, 6.4 FLAT ZINC	F81053-1	5
18	NUT, M10-8-B HEX NYLON ZINC LOCK	F81033-1	2
19	NUT, M6 8 HEX ZINC	F81031-1	1
20	BOLT, M6X30-5.8 HEX HEAD FULL THREAD	F81001-13	1
21	BUSHING, BLADE GUIDE ARM	095936	1
-	STUD BOLT ASSEMBLY, ARM LEVER CONNECTION	094204	1

REF.	DESCRIPTION (◆ Indicates Parts Available In Assemblies Only)	PART #	QTY	
22	BOLT, ZINC-PLATED STUD	094203-1	1	
23	SEAT, BALL	093824-1	2	
24	STUD, 16/SW-13 DIN71803-C BN486 BALL	093823	2	
25	NUT, M10 8 HEX ZINC	F81033-3	2	
26	WASHER, 10.5 FLAT ZINC	F81055-1	2	
27	NUT, M10-8-B HEX NYLON ZINC LOCK	F81033-1	2	
28	BOLT, M10X50-8.8 HEX HEAD FULL THREAD ZINC	F81003-4	2	
29	CLAMP, 5/8 EMT COATED	010748	1	
30	GUARD, BOTTOM	525592-1	1	
31	BUSHING, 6.5/16-10.5	525463-1	1	
32	NUT, M6-8-B HEX NYLON ZINC LOCK	F81031-2	2	
33	WASHER, 6.5 SPECIAL FLAT ZINC	F81053-11	1	
34	WASHER, Z 6.1 SPLIT LOCK ZINC	F81053-3	1	
35	BOLT, M6X20 8.8 HEX HEAD FULL THREAD ZINC	F81001-2	2	
36	BOLT, M6X25 5.8 HEX HEAD FULL THREAD ZINC	F81001-3	1	
37	WASHER, 8.2 SPLIT LOCK ZINC	F81054-4	1	
38	BOLT, M8X16-8.8-B HEX HEAD FULL THREAD ZINC	F81002-20	1	

SECTION 5 BLADE WHEELS & TENSIONER

5.1 Blade Wheel Assembly, Drive Side

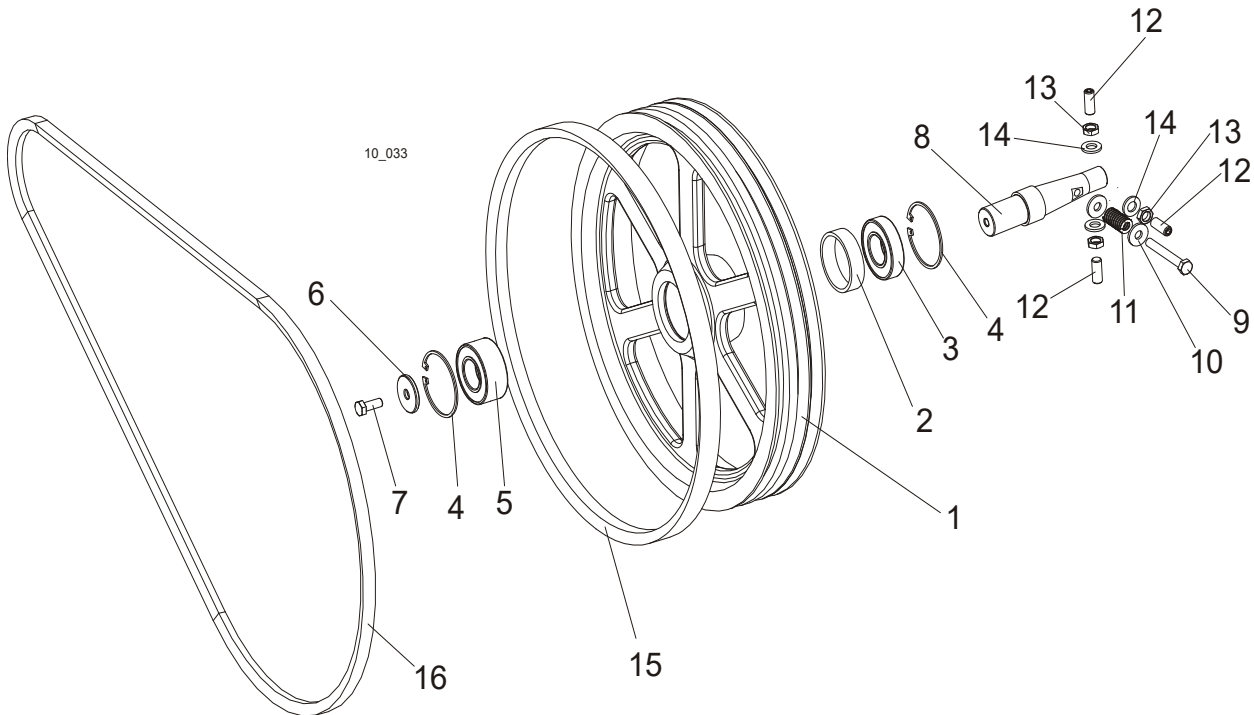

REF	DESCRIPTION (◆ Indicates Parts Available In Assemblies Only)	PART #	QTY.
	WHEEL ASSEMBLY, DRIVE SIDE BLADE	091612	1
1	BLADE WHEEL, DRIVE SIDE PTD	090646-1	1
2	BUSHING, SPACER	096778	1
3	BEARING, 6207 2RS 35X72X17 FAG	014811	1
4	RING, W72 INSIDE RETAINING	F81090-4	2
5	BEARING, 3207B, 2RSR TVH FAQ	092005	1
6	WASHER, DRIVE SIDE BLADE WHEEL	092006	1
7	SCREW, M10X25-8.8 HEX HEAD FULL THREAD ZINC	F81003-11	1
8	SHAFT, DRIVE SIDE BLADE WHEEL	093850	1
9	BOLT, M10X75-8.8 HEX HEAD ZINC	F81003-15	1
10	WASHER, 10.5 SPECIAL FLAT ZINC	F81055-6	2
11	SPRING, 19X38 COMPRESSION	034430	1
12	SCREW, M12X1,25X30 DIN913 SET STAINLESS STEEL	F81016-1	3
13	WASHER, 13 FLAT ZINC	F81056-1	3
14	NUT, M12X1.25 DIN439 THIN STAINLESS STEEL	F81034-9	3
15	V-BELT, B57	P04185-2	1
16	DRIVE BELT, BX81	014819	1

5.2 Blade Wheel Assembly, Idle Side

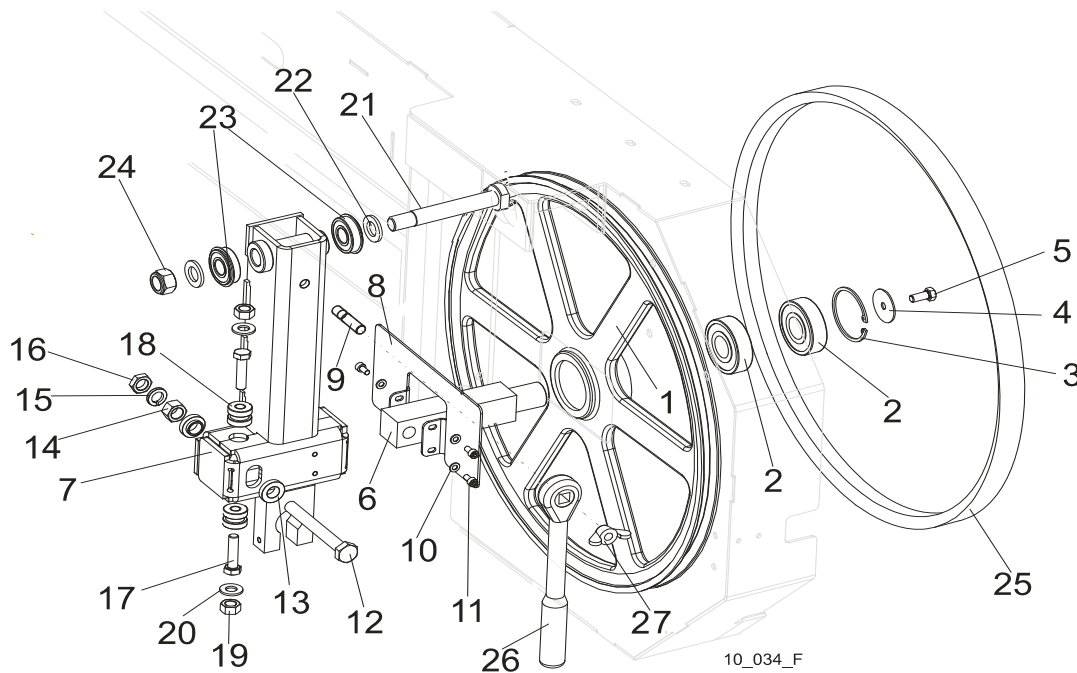

REF	DESCRIPTION (◆ Indicates Parts Available In Assemblies Only)	PART #	QTY.
	WHEEL ASSEMBLY, IDLE SIDE BLADE	A08218	1
1	WHEEL ASSEMBLY, 18.62" BLADE IDLE SIDE	P08125	1
2	BEARING, 6305 2RS NSK IDLE SIDE WHEEL	P08066	2
3	RING, 2 7/16" INSIDE RETAINING	F04254-21	1
	HOUSING, LT10 & LT15 IDLER SHAFT, COMPLETE	100180	1
4	WASHER, IDLE SIDE WHEEL RETAINING	093854-1	1
5	BOLT, M8X25-8.8-B HEX HEAD FULL THREAD ZINC	F81002-5	1
6	SHAFT, IDLE SIDE BLADE WHEEL (METRIC)	096045	1
	HOUSING, IDLER SHAFT COMPLETE	508145	1
7	HOUSING, IDLER SHAFT WELDED/PAINTED	508144-1	1
8	COVER, HOUSING, IDLER SHAFT COMPLETE PAINTED	508128-1	1
9	BOLT M10X35-8.8	F81003-9	1
10	WASHER, 5.3 FLAT ZINC	F81052-1	3
11	SCREW, M5x10 DIN912 A2-70 HEX SOCKET HEAD	F81000-23	3
12	BOLT, M12X1,25X100-8.8 HEX HEAD FULL THREAD ZINC	F81004-41	1
13	WASHER, FLANGED ZINC-PLATED	086769-1	2
14	NUT, M12X1,25 -8 HEX ZINC	F81034-8	1
15	WASHER, 12.2 SPLIT LOCK ZINC	F81056-2	1
16	NUT, M12x1.25 DIN439 THIN STAINLESS STEEL	F81034-5	1
17	BOLT, M10 X 40-8.8 Fe/Zn5, PN-M/82105	F81003-16	2
18	BUSHING, M10 IDLER SHAFT HOUSING	086987	2
19	NUT, M10-8-B HEX HEAD ZINC	F81033-3	2
20	WASHER, 10.5 FLAT ZINC	F81055-1	2
21	PIN, IDLER ARM MOUNT	086404	1
22	WASHER, 17 FLAT ZINC	F81058-1	2
23	BEARING, 6203-2RS NR NSK W/SNAP RING	086395	2
24	NUT, M16-8 HEX NYLON ZINC LOCK	F81036-2	1
25	V-BELT, B57	P04185-2	1

5**BLADE WHEELS & TENSIONER***Blade Wheel Assembly, Idle Side*

26	WRENCH, BLADE TENSION	091620	1	
27	NUT WING M10	F81033-8	1	

5.3 Blade Tensioner Assembly

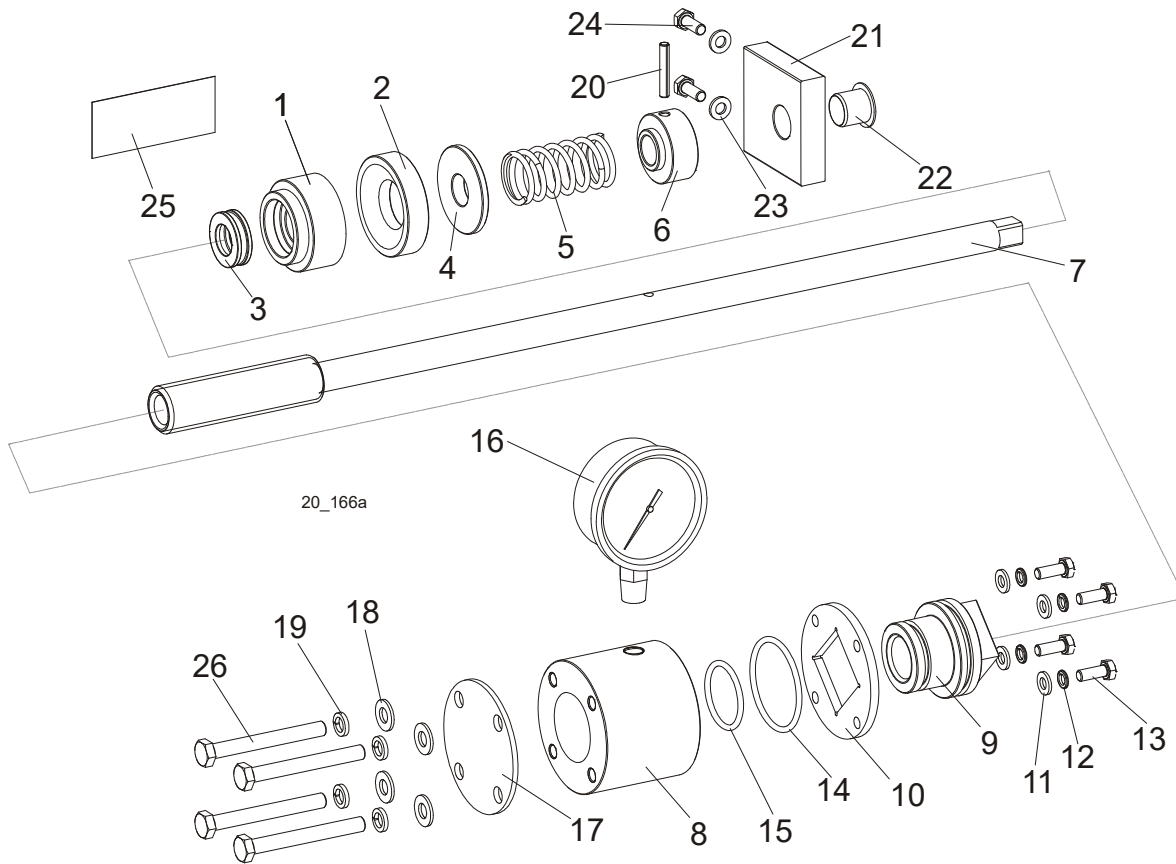

REF.	DESCRIPTION (◆ Indicates Parts Available In Assemblies Only)	PART #	QTY.
	COMPLETE BLADE TENSIONER	510640	1
1	HOUSING, BALL THRUST BEARING	510635	1
2	SOCKET, BEARING HOUSING	510634-1	1
3	BEARING, 51103. BALL THRUST	086675	1
4	WASHER	510633-1	1
5	SPRING, n3mm	088992	1
6	BUSHING, BLADE TENSIONER SCREW	510636-1	1
7	SCREW, BLADE TENSIONER ZINC-PLATED	510650-1	1
	CYLINDER ASSEMBLY	510641	1
8	CYLINDER	510657-1	1
9	PISTON	510638	1
10	PLATE, CYLINDER	510490-1	1
11	WASHER, 6.4 FLAT ZINC	F81053-1	4
12	WASHER, Z 6.1 SPLIT LOCK ZINC	F81053-3	4
13	BOLT, M6x16-8.8 HEX HEAD FULL THREAD ZINC	F81001-15	4
14	O-RING, 46.2x3	510646	1
15	O-RING, 32.2x3	510647	1
16	GAUGE, 3000psi/200 bar OIL PRESSURE	505176	1
17	PLATE, CYLINDER COVER	510642-1	1
18	WASHER, 8.4 FLAT ZINC	F81054-1	4
19	WASHER, 8.2 SPLIT LOCK ZINC	F81054-4	4

20	PIN, 5x30 ROLL ZINC	F81044-21	1	
21	BLOCK, TENSIONER HANDLE MOUNT	096730	1	
22	BUSHING, GFM-1618-17	089589	1	
23	WASHER, 6.4 FLAT ZINC	F81053-1	2	
24	BOLT, M6x16-8.8 HEX HEAD FULL THREAD ZINC	F81001-15	2	
25	DECAL, PRESSURE VALUES	510643	1	
26	BOLT, M8x70-8.8 HEX HEAD ZINC	F81002-71	4	

5.4 Motor

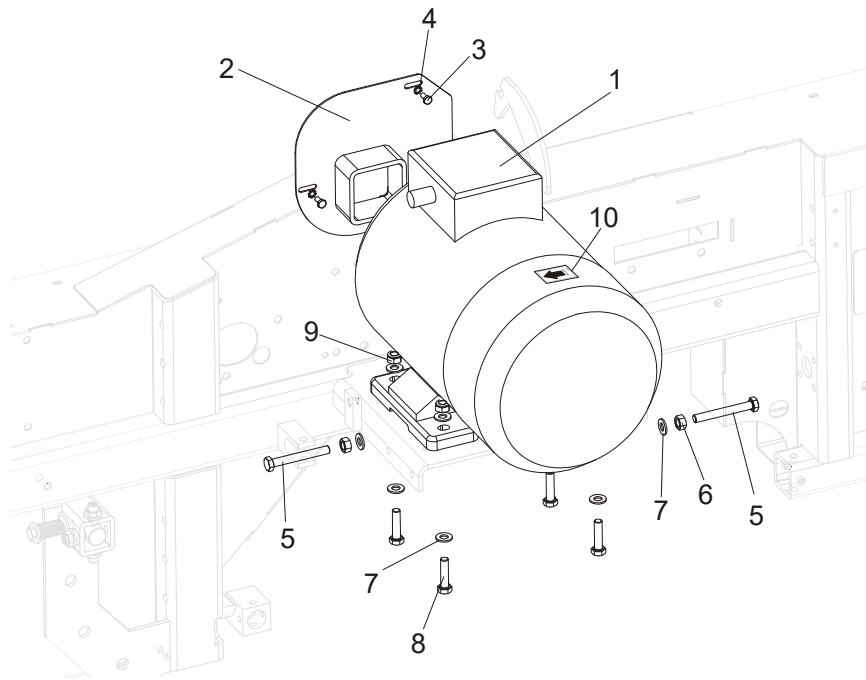

REF	DESCRIPTION (◆ Indicates Parts Available In Assemblies Only)	Part #	Qty.
1	MOTOR, 1LA7130-2AA60 5,5KW,400V,50HZ ELECTRIC	095785	1
2	MOTOR SHAFT COVER, E11 E15 PAINTED	095335-1	1
3	BOLT, M6X12-8.8 HEX HEAD FULL THREAD ZINC	F81001-7	3
4	WASHER, 6.4 STAR LOCK ZINC	F81053-2	3
5	BOLT, M10X80-8.8 HEX HEAD FULL THREAD ZINC	F81003-76	2
6	NUT, M10-8-B HEX ZINC	F81033-3	2
7	WASHER, 10.5 FLAT ZINC	F81055-1	10
8	BOLT, M10X40-8.8 HEX HEAD FULL THREAD ZINC	F81003-16	4
9	NUT, M10-8-B NYLON HEX ZINC LOCK	F81033-1	4
10	DECAL, ROTATION DIRECTION - 2925 RPM	S20097F ¹	1

¹ Included in 099419 - LT10 Pictographic Decal Kit.

5.5 Power Cord Bracket

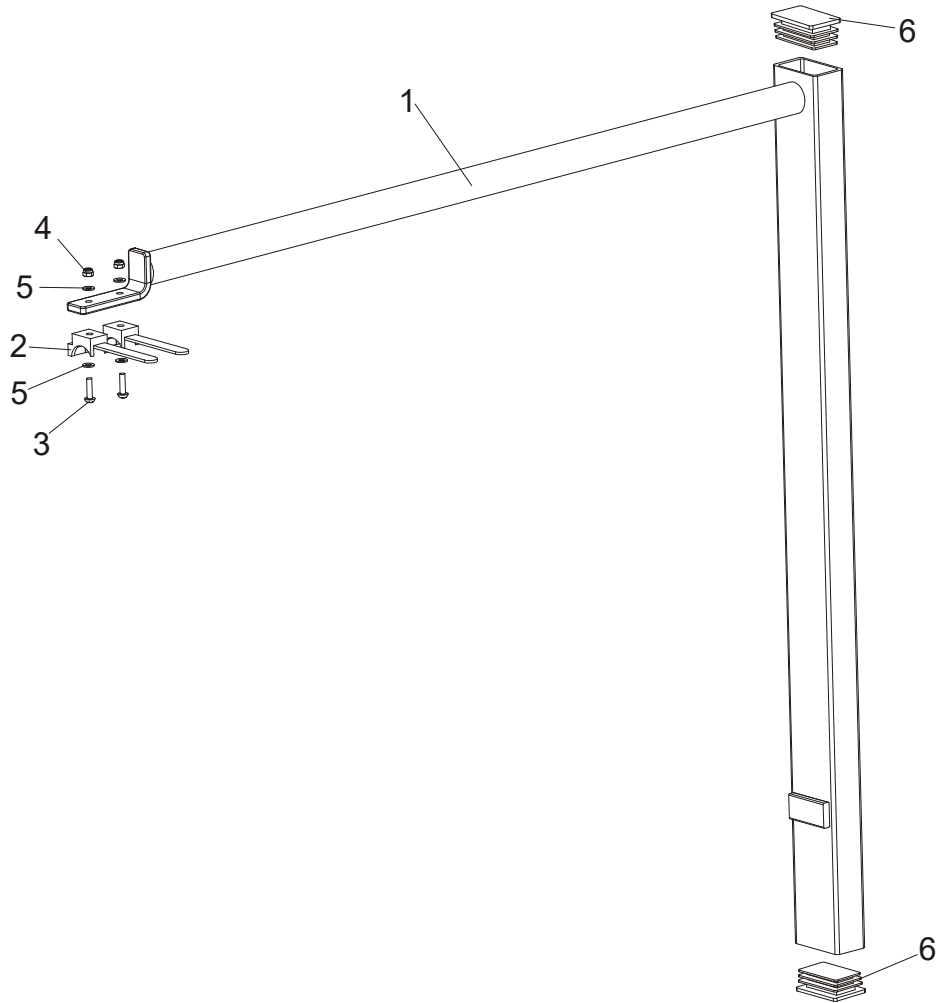

REF	DESCRIPTION (◆ Indicates Parts Available In Assemblies Only)	Part #	Qty.	
	BRACKET, LT10 POWER CORD COMPLETE	097449	1	
1	Bracket, Power Cord Painted LT10	086132-1	1	
2	Holder, UP30 Cable Plastic Tie	F81082-1	2	
3	Screw, M4x16 5,8-B Cross Recessed Pan Head Zinc	F81011-42	2	
4	Nut, M4-B Hex Nylon Zinc Lock	F81029-1	2	
5	Washer, 4.3 Flat Zinc	F81051-2	4	
6	Cap, 50x30 Black	095919	2	

5.6 Blade brake

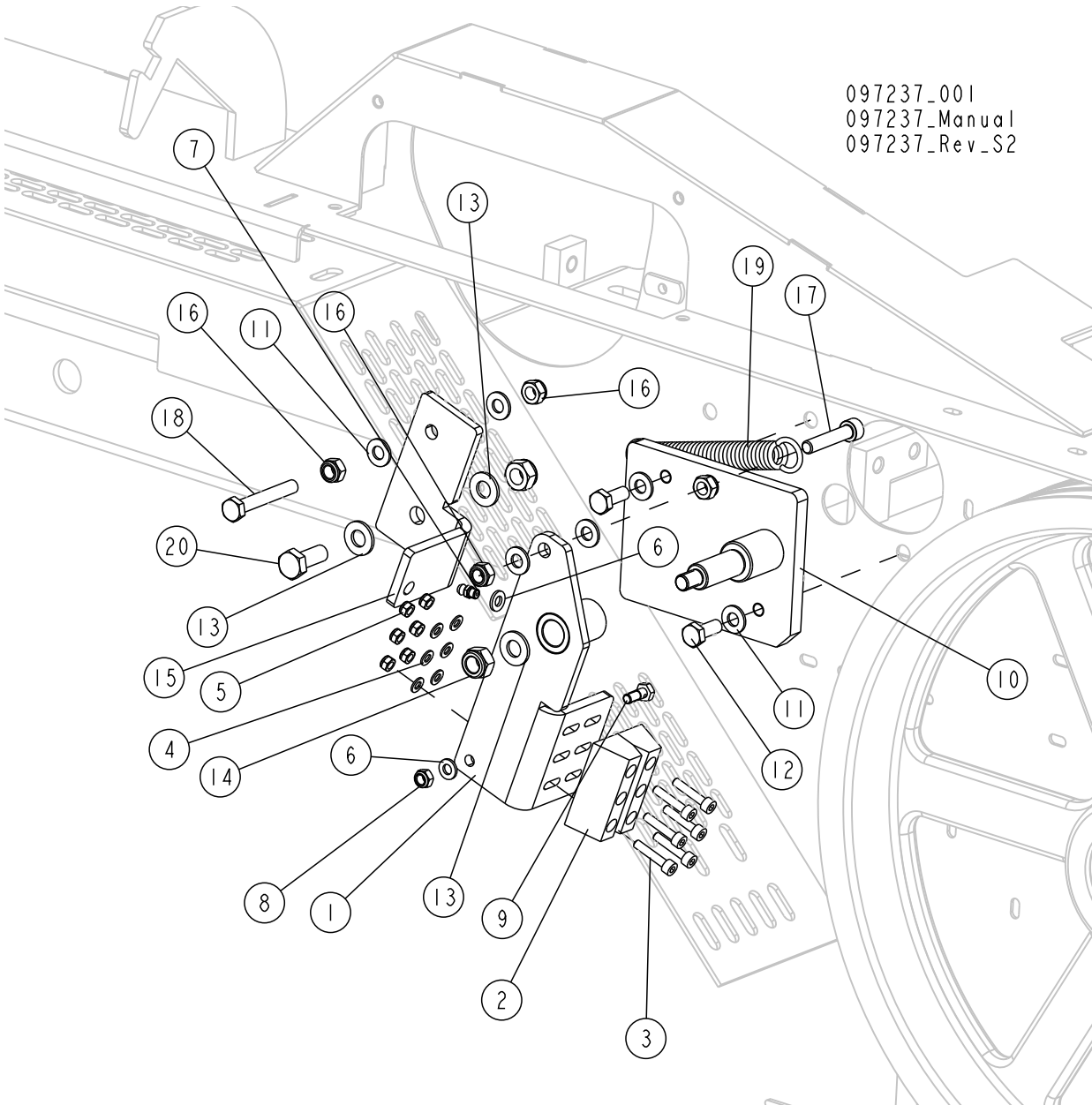

097237_001
097237_Manual
097237_Rev_S2

REF	DESCRIPTION (* Indicates Parts Available in Assemblies Only)	PART #	QTY
	BRAKE BLADE LT10 COMPLETE	097367	1
1	ARM BRAKE WELDED/PAINTED	097366-1	1
2	BLOCK, DRIVE BELT TENSIONER BRAKE	092111	2
3	BOLT, M5 x 25-5.8-Fe/Zn5, PN-M/82302	F81000-7	6
4	WASHER, 5.3 FLAT ZINC	F81052-1	6
5	NUT, M5-8-Fe/Zn5 DIN985	F81030-2	6
6	WASHER, 6.4 FLAT ZINC	F81053-1	2
7	FITTING, M6 GREASE	086280	1
8	NUT, M6-8-B HEX NYLON ZINC LOCK	F81031-2	1
9	BOLT, THROTTLE CABLE CLAMP ZINC-PLATED	088120-1	1

REF	DESCRIPTION (* Indicates Parts Available in Assemblies Only)	PART #	QTY	
10	PLATE BRAKE WELDED/PAINTED	097363-1	1	
11	WASHER, 8.4 FLAT ZINC	F81054-1	6	
12	BOLT,M8X20-5.8 HEX HEAD FULL THREAD ZINC	F81002-1	2	
13	WASHER, 10.5 FLAT ZINC	F81055-1	3	
14	NUT, M10-8-B HEX NYLON ZINC LOCK	F81033-1	2	
15	BRACKET, CABLE DRIVE BELT TENSIONER	097368-1	1	
16	NUT, M8-8-B HEX NYLON ZINC LOCK	F81032-2	4	
17	SCREW, M8X40-8.8 HEX SOCKET HEAD CAP ZIN	F81002-29	1	
18	BOLT, M8 X 55 8.8 Fe/Zn5, PN-M/82101	F81002-8	1	
19	SPRING, FI 1,9 X FI 14,2 X 104	091865	1	
20	BOLT, M10 X 25 8.8 Fe/Zn5, PN-M/82105	F81003-31	1	
21	WASHER, LT15 DRIVE WHEEL ZINC	086286-1	1	
22	BOLT, M10X25-8.8-FE/ZN5	F81003-11	1	

SECTION 6 SAW HEAD

6.1 Blade Housing Cover

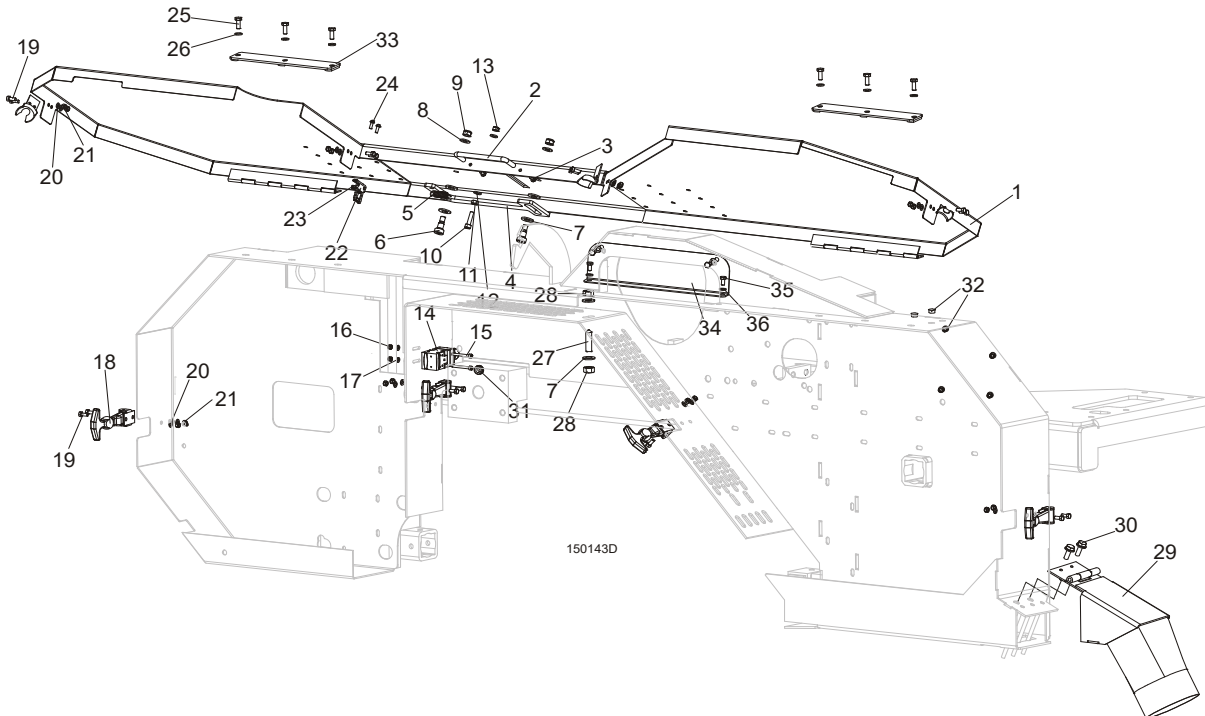

REF	DESCRIPTION (◆ Indicates Parts Available In Assemblies Only)	PART #	QTY.
	COVER, LT15 FRONT COMPLETE	098678	1
1	Cover Weldment, LT10/15/20 Blade Housing Painted	096776-1	1
2	Handle w/Bolt	P08065	1
3	Screw, #8-32x3/8 Self-tapping	F05015-8	2
4	Pawl, Locking Painted	090643-1	1
5	Spring, 1.6x12x38 Extension	092208	1
6	Bolt, 10/M8x12-12.9 ISO-7379 Shoulder	F81003-62	2
7	Washer, 10.5 Flat Zinc	F81055-1	4
8	Washer, 8.4 Flat Zinc	F81054-1	2
9	Nut, M8-8-B Hex Nylon Zinc Lock	F81032-2	2
10	Screw, M6x25-8.8 Hex Socket Head Cap Zinc	F81001-41	1
11	Nut, M6-8 Hex Zinc	F81031-1	1
12	Washer, 6.4 Flat Zinc	F81053-1	2
13	Nut, M6-8-B Hex Nylon Zinc Lock	F81031-2	1
14	SWITCH, AZ17-11ZRK SAFETY	094232	1
15	SCREW, M4X35-8.8 HEX SOCKET HEAD CAP ZINC	F81011-34	2
16	NUT, M4-B HEX NYLON ZINC LOCK	F81029-1	2
17	WASHER, 4.3 FLAT ZINC	F81051-2	2
18	LATCH, FLEXIBLE DRAW	014829	4
19	BOLT, M5X12-5.8 HEX HEAD FULL THREAD ZINC	F81000-5	8
20	WASHER, 5.3 FLAT ZINC	F81052-1	8
21	NUT, M5-8 DIN 985 ZINC-PLATED	F81030-2	8

22	KEY, A217/170-B5 SAFETY SWITCH	094422	1	
23	NUT, M4-B HEX NYLON ZINC LOCK	F81029-1	2	
24	SCREW, M4X12-5.8-B CROSS RECESSED PAN HEAD ZINC	F81011-43	2	
25	BOLT, M6X16 8.8 HEX HEAD FULL THREAD ZINC	F81001-15	6	
26	WASHER, 6.4 FLAT ZINC	F81053-1	6	
27	SCREW, M10X40-45H HEX SOCKET SET CONE POINT ZINC	F81003-61	1	
28	NUT, M10-8-B HEX ZINC	F81033-3	2	
29	CHUTE, LT10/15/20 SAWDUST	100903-1	1	
30	BOLT, M8X16-8.8-B HEX HEAD FULL THREAD ZINC	F81002-20	2	
31	GROMMET, 22mm DIA. RUBBER	087400	1	
32	PLUG, SR1086-9,5	096846	6	
33	PLATE, COVER MOUNT	086701-1	2	
34	COVER, SAW HEAD MOUNT	096788-1	1	
35	BOLT, M6X12MM HEX HEAD ZINC	F81001-7	4	
36	WASHER, M6 FLAT ZINC	F81053-1	4	

6.2 Water Lube Assembly

097237_005
097237_Manual

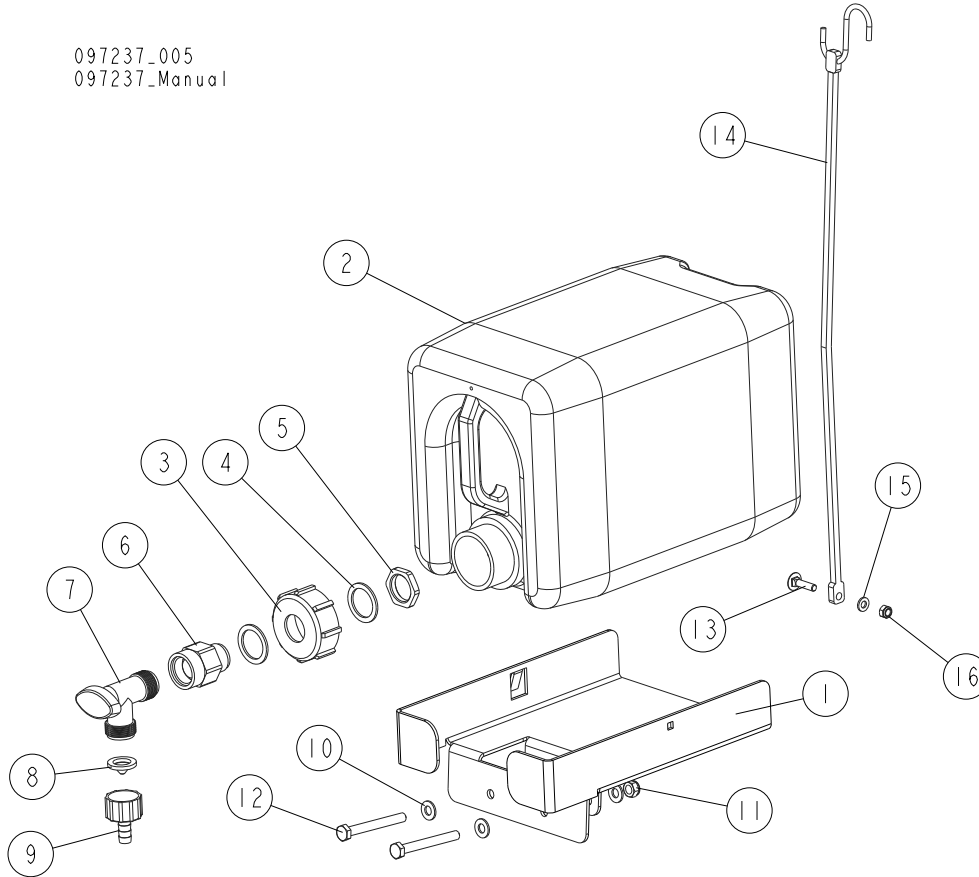

REF	DESCRIPTION (* Indicates Parts Available in Assemblies Only)	PART #	QTY
	WATER BOTTLE ASSEMBLY 10 L	517062	1
1	BRACKET BOTTLE WATER	516436-1	1
	BOTTLE, WATER COMPLETE	711401	1
2	BOTTLE, WATER (10L)	711400	1
3	NUT, BOTTLE WATER	513867	1
4	O-RING, 35X26X2	513869	2
5	GLAND NUT, 3/4 NPT 467616	513868	1
6	FITTING, 3/4FPTX3/4MPT	014636	1
7	VALVE, 3/4 NPT ELBOW 3/4 MALE OUTLET PVC	014100	1
8	FILTER, WATER LUBE	016086	1
9	REDUCER, 5/8NPT/3/8BARB WATER LUBE	014113	1
10	WASHER, 8.4 FLAT ZINC	F81054-1	4
11	NUT, M8-8-B HEX NYLON ZINC LOCK	F81032-2	2
12	BOLT, M8X70 8.8 HEX HEAD ZINC	F81002-71	2
13	SCREW M6X25-8.8-FE/ZN5 PN/M-82406	F81001-20	1
14	STRAP, 15 RUBBER W/S HOOKS	P07461	1
15	WASHER, 6.4 FLAT ZINC	F81053-1	1
16	NUT, M6-8-B HEX NYLON ZINC LOCK	F81031-2	1

6.3 LT10 Saw Head Decals

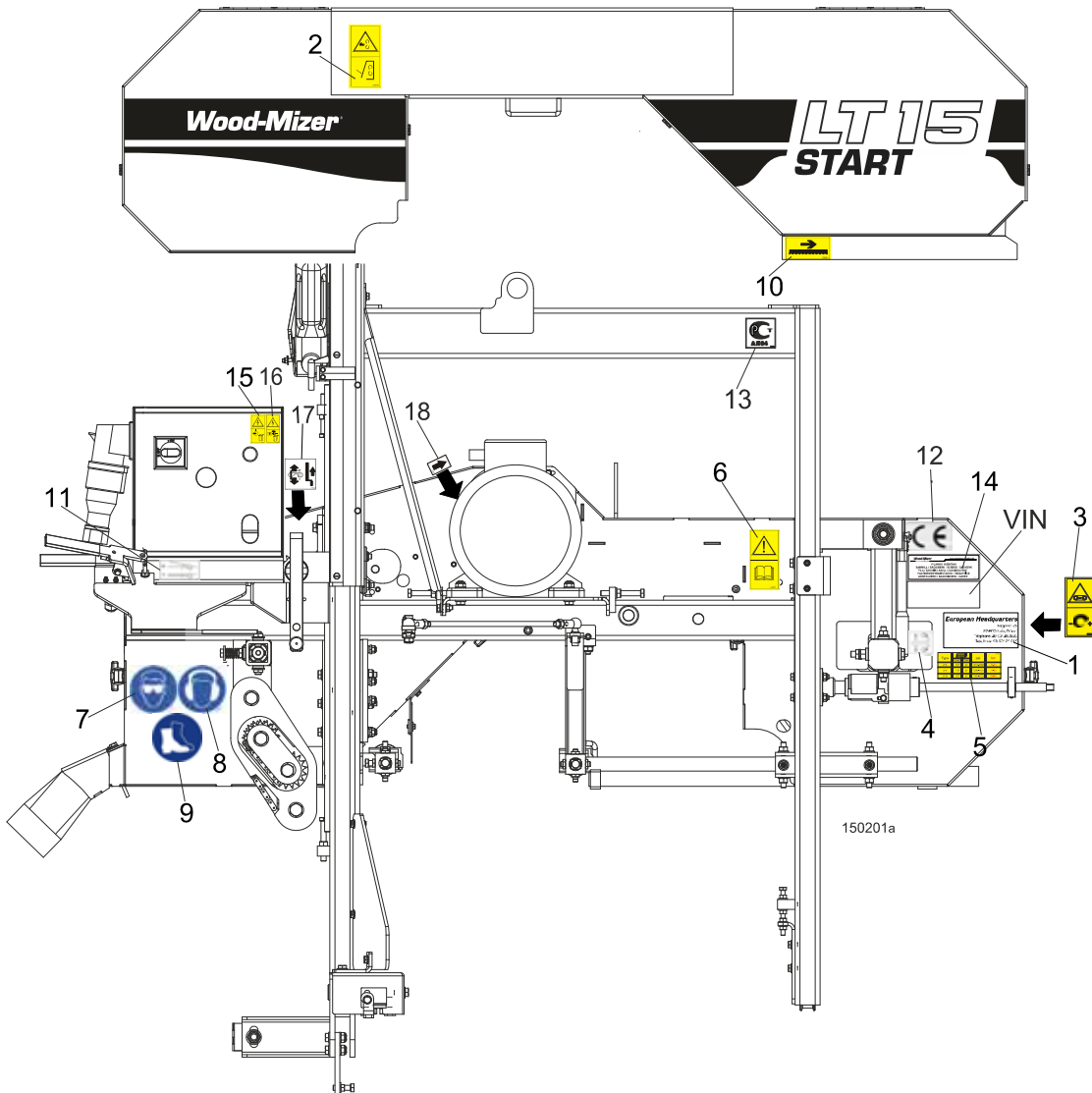

REF	DESCRIPTION (◆ Indicates Parts Available In Assemblies Only)	Part #	Qty.
	PICTOGRAPHIC DECAL KIT, LT10	099419	1
	DECAL, SAWMILL NAME	528776	1
1	DECAL, EUROPEAN HEADQUARTERS ADDRESS	015841	1
2	DECAL, SAWMILL COVERS CAUTION	099220	1
3	DECAL, BLADE TENSION (PICTOGRAM)	099219	1
4	DECAL, BLADE ALIGNMENT	P11789	1
5	DECAL, BLADE TENSION INDICATOR ADJUSTMENT	510643	1
6	DECAL, READ OPERATOR'S MANUAL (PICTOGRAM)	096317	1
7	DECAL, EYE PROTECTION WARNING (PICTOGRAM)	S12004G	1
8	DECAL, EAR PROTECTION WARNING (PICTOGRAM)	S12005G	1
9	DECAL, USE SAFETY BOOTS (PICTOGRAM)	501465	1
10	DECAL, BLADE MOVEMENT DIRECTION (PICTOGRAM)	096321	1
11	DECAL, SAFETY HANDLE	501477	1

12	DECAL, CE CERTIFIED SAWMILL (SMALL)	P85070	1	
13	DECAL, RUSSIAN SAFETY CERTIFICATION	099401	1	
14	DECAL, INTERNATIONAL SAWMILL NAME	501466	1	
15	DECAL, HIGH VOLTAGE INSIDE THE ELECTRIC BOX (PICTOGRAM)	096316	1	
16	DECAL, REMOVE THE PLUG BEFORE OPENING THE BOX (PICTOGRAM)	096319	1	
17	DECAL, POWER FEED SYSTEM ENGAGEMENT (PICTOGRAM)	099226	1	
18	DECAL, MOTOR REVOLUTIONS DIRECTION	S20097	1	

6.4 Control Box

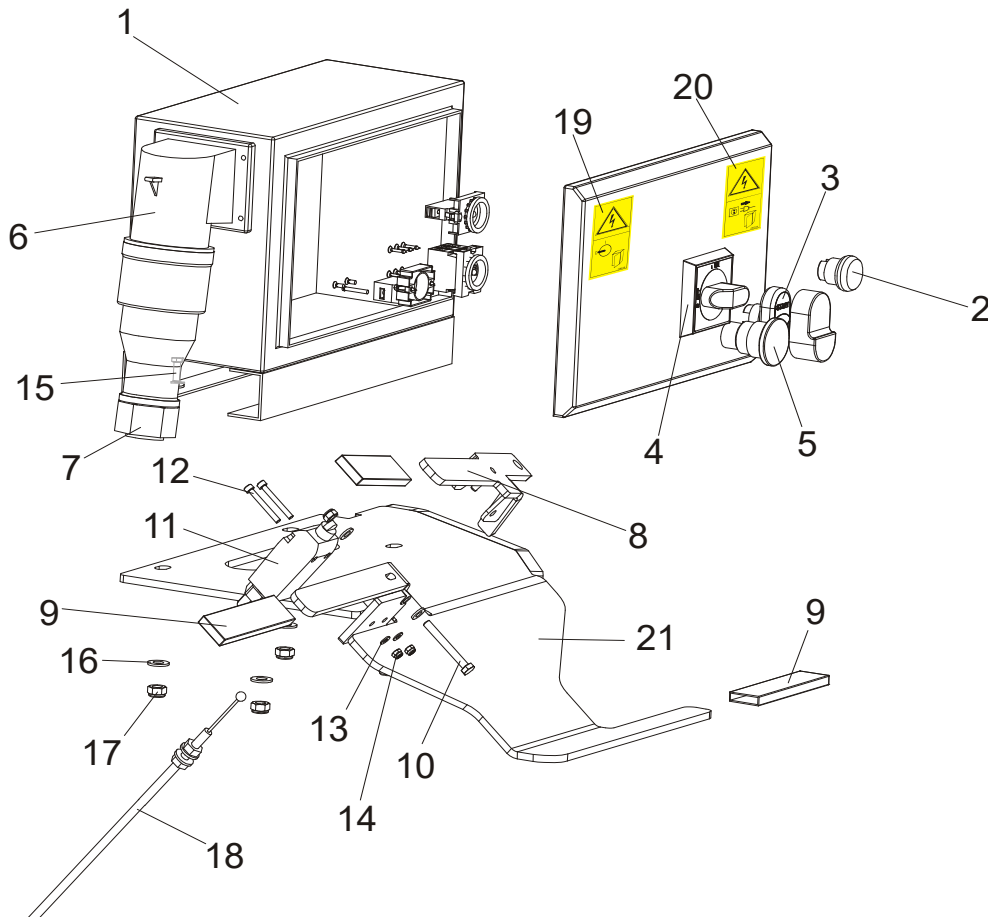

REF	DESCRIPTION (◆ Indicates Parts Available In Assemblies Only)	Part #	Qty.
	BOX, LT10 ELECTRIC	096001-M	1
	BOX, LT10 ELECTRIC (NORWEGIAN VERSION)	096001-M2	1
1	Box, Electric	092628	1
2	Light, M22 White-LED 24V Control	090448	1
3	Start/Stop Switch 24V	090452	1
4	Switch, ABB OT40 F3	502312	1
	Knob, OHB S2A1 ABB Switch	502312-1	1
	Axle, OXS6160 ABB Switch	502312-2	1
5	Switch, XB4 BS542 Emergency Stop	086556	1
6	Plug, 16A	E85239	1
7	Plug in socket, 16A 400V IP57 31243 Bals	E85240	1
8	HANDLE, BLADE ENGAGEMENT WLDMT/PTD	097221-1	1
9	COVER, RRWA-91626-110 GRIP	086875	3
10	BOLT, M6X50-8.8 HEX HEAD ZINC	F81001-62	1
11	SWITCH, GLCB01C LIMIT	100910	1
12	SCREW, M4X35 -8.8 HEX SOCKED HEAD CAP ZINC	F81011-34	2
13	WASHER, 4.3 FLAT ZINC	F81051-2	2
14	NUT, M4-B HEX NYLON ZINC LOCK	F81029-1	2
15	BOLT, M8X25-8.8-B HEX HEAD FULL THREAD ZINC	F81002-5	4

16	WASHER, 8.4 FLAT ZINC	F81054-1	8	
17	NUT, M8-8-B HEX NYLON ZINC LOCK	F81032-2	4	
18	CABLE, THROTTLE	089450	1	
19	DECAL, HIGH VOLTAGE INSIDE THE ELECTRIC BOX (PICTOGRAM)	096316	1	
20	DECAL, REMOVE THE PLUG BEFORE OPENING THE BOX (PICTOGRAM)	096319	1	
21	T-HANDLE, LT10	507386-1	1	



SECTION 7 FEED SYSTEM

7.1 Track Rail, Rollers & Travel Pins

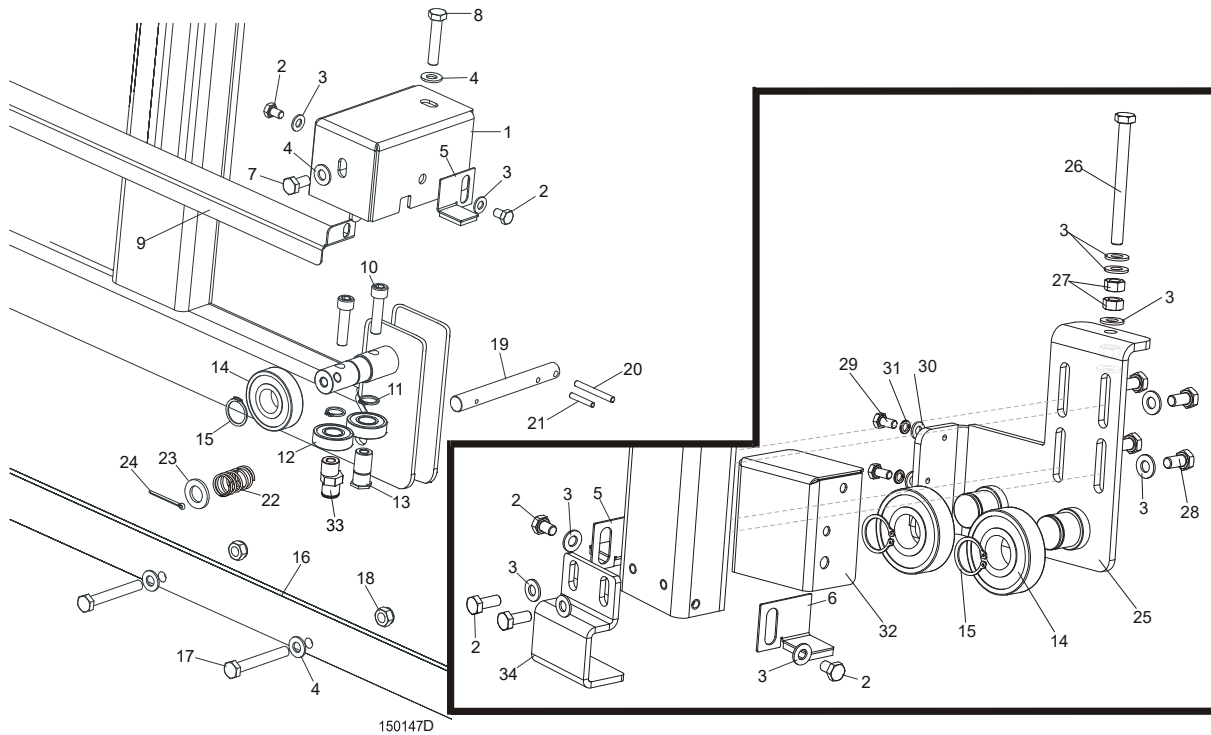

150147D

REF	DESCRIPTION (◆ Indicates Parts Available In Assemblies Only)	PART #	QTY.
1	HOUSING, TRACK ROLLER PAINTED	086739-1	2
2	BOLT, M8X12-8.8 HEX HEAD FULL THREAD ZINC	F81002-6	8
3	WASHER, 8.4 FLAT ZINC	F81054-1	16
4	WASHER, 10.5 FLAT ZINC	F81055-1	13
5	PLATE, RIGHT TRACK WIPER	086322	2
6	PLATE, LEFT TRACK WIPER	086323	2
7	BOLT, M10 X 20 5.8 HEX HEAD FULL THREAD ZINC	F81003-1	2
8	BOLT, M10X50-8.8 HEX HEAD FULL THREAD ZINC	F81003-4	2
9	COVER, MIDDLE TRACK	086745	1
10	SCREW, M10X40 HEX SOCKET HEAD CAP ZINC	F81003-22	4
11	RING, Z 17 OUTSIDE RETAINING	F81090-21	4
12	BEARING, 6203-2RS ROLLING	086114	4
13	SHAFT, SIDE BEARING MOUNT ZINC-PLATED	086645-1	2
14	BEARING, 6305-2RS CX	085706	4
15	RING, 25Z OUTSIDE RETAINING	F81090-22	4
16	RAIL, LT15 1950 (LT15S3) TRACK ZINC-PLATED	094427-1	3
	RAIL, LT15 2700 (LT15M2) TRACK ZINC-PLATED	094696-1	2
17	BOLT, M10X75-8.8 HEX HEAD ZINC	F81003-15	9/13 ¹

18	NUT, M10-8-B HEX NYLON ZINC LOCK	F81033-1	9/13 ²	
19	PIN, TRAVEL LOCK ZINC-PLATED	086743-1	2	
20	PIN, 6X50 ROLL ZINC	F81045-1	2	
21	PIN, 5 X 30 ROLL ZINC	F81044-21	2	
22	SPRING, 18X37X1.8 COMPRESSION ZINC-PLATED	087301	2	
23	WASHER, 17 FLAT ZINC	F81058-1	2	
24	PIN, 4 X 25 COTTER ZINC	F81043-2	2	
25	BRACKET, ROLLER	506703-1	1	
26	BOLT, M8X90-8.8 HEX HEAD FULL THREAD ZINC	F81002-16	1	
27	NUT, M8-8-B HEX ZINC	F81032-1	3	
28	BOLT, M8X16-8.8-B HEX HEAD FULL THREAD ZINC	F81002-20	4	
29	BRACKET MAST GUIDE	503768-1	1	
30	WASHER, 6.4 FLAT ZINC	F81053-1	2	
31	WASHER, Z 6.1 SPLIT LOCK ZINC	F81053-3	2	
32	COVER, ROLLER	501783-1	1	
33	SHAFT, OUTER ECCENTRIC E=3,3-ZINC	098898-1	2	

¹ Number of bolts for one bed section.

² Number of nuts for one bed section.

7.2 Track Rail, Rollers & Travel Pins

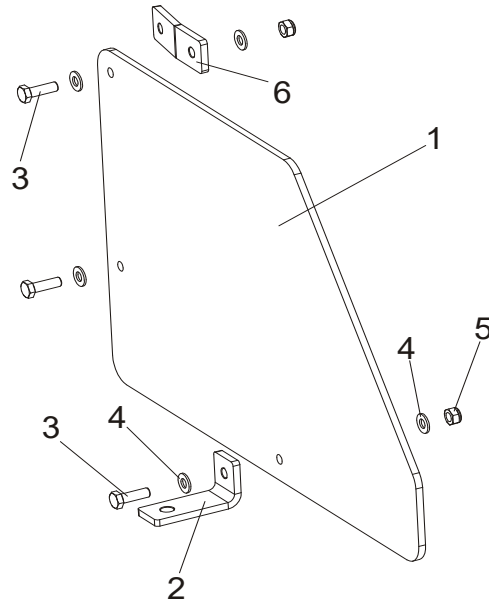

REF	DESCRIPTION (◆ Indicates Parts Available In Assemblies Only)	Part #	Qty.	
	GUARD, LT15 COMPLETE LOWER	093858	1	
1	Plate, LT15 Lower Guard	093859	1	
2	Bracket, Lower PTD	086172-1	1	
3	Bolt, M8x25-8.8 Hex Head Full Thread	F81002-5	3	
4	Washer, 8.4 Flat Zinc	F81054-1	6	
5	Nut, M8-8-B Hex Nylon Zinc Lock	F81032-2	3	
6	Bracket, Side PTD	086171-1	2	

SECTION 7 UP/DOWN SYSTEM

7.1 Up/Down Crank Assembly

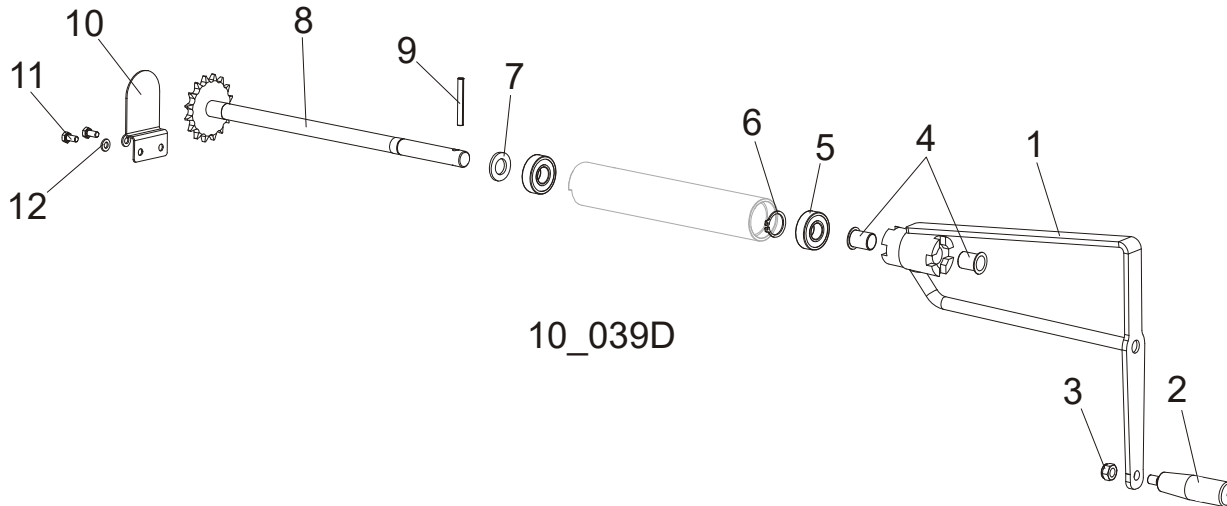

REF.	DESCRIPTION (◆ Indicates Parts Available In Assemblies Only)	Part #	Qty
	FEED CRANK ASSEMBLY, LT15/MP100/HR110	508239	1
1	CRANK WELDMENT, LT15	508238-1	1
2	KNOB, 12992M10 PLASTIC CRANK HANDLE	086338	1
3	NUT, M10-8-B HEX NYLON ZINC LOCK	F81033-1	1
4	BUSHING, GFM-1719-25	094142	2
5	BEARING, 6203-2RS	086114	2
6	RING, Z17 OUTSIDE RETAINING	F81090-21	1
7	WASHER, 17 FLAT ZINC	F81058-1	1
8	SHAFT, LT15 W/SPROCKET	097242-1	1
9	PIN, 6X50 ZINC ROLL	F81045-1	1
10	GUARD, UPPER LT15 SAW HEAD SPROCKET	092567-1	1
11	BOLT, M6X12-8.8 HEX HEAD FULL THREAD ZINC	F81001-7	2
12	WASHER, 6.4 FLAT ZINC	F81053-1	2

7 UP/DOWN SYSTEM

Drill Bracket (Option)

7.2 Drill Bracket (Option)

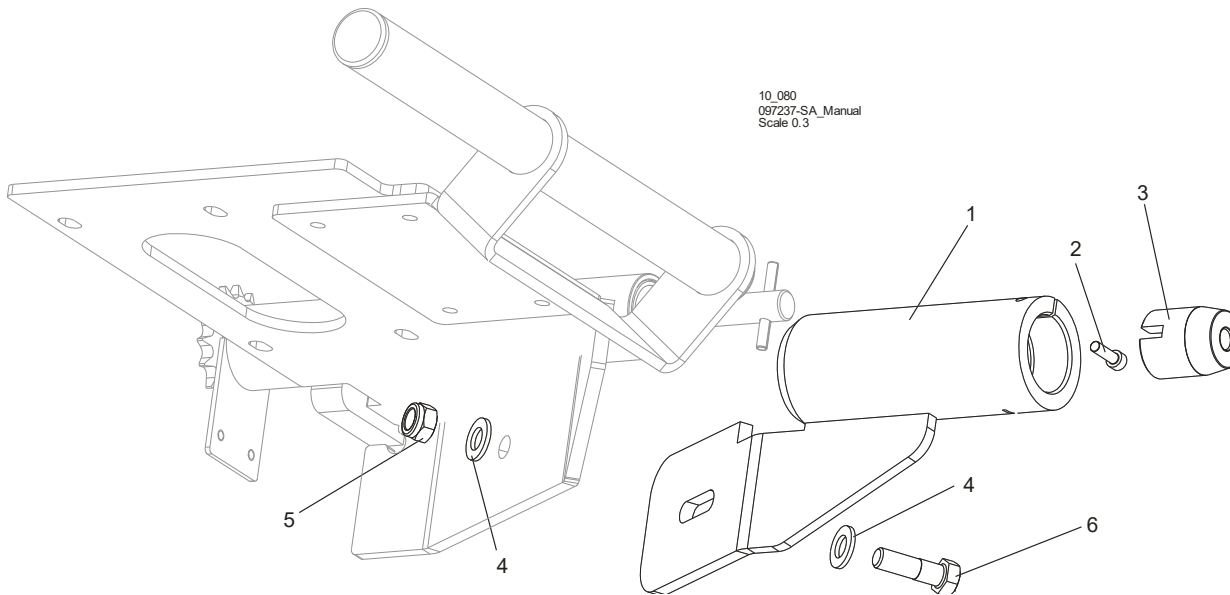

REF.	DESCRIPTION (◆ Indicates Parts Available In Assemblies Only)	Part #	Qty
	BRACKET, DRILL	512248	1
1	BRACKET, LT10	512241-1	1
2	SCREW, M6 X 20 8.8 HEX SOCKET HEAD CAP ZINC	F81001-22	1
3	BUSHING, DRIVING	512244	1
4	WASHER, 13 FLAT ZINC	F81056-1	2
5	NUT, M12-8 HEX NYLON ZINC LOCK	F81034-2	1
6	BOLT, M12X40-8.8 HEX HEAD ZINC	F81004-1	1

7.3 Up/Down Drive Sprocket Assembly

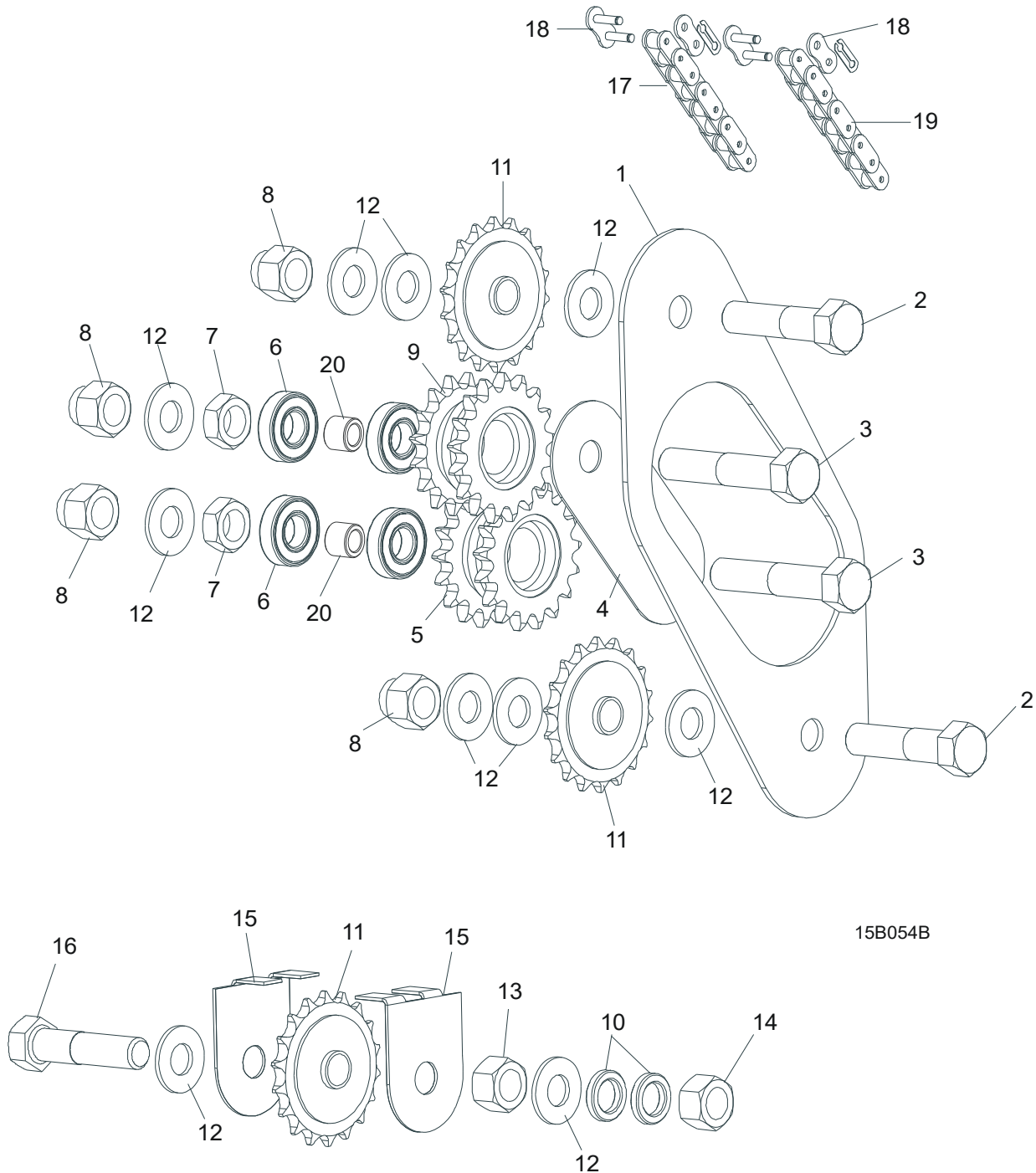

15B054B

REF.	DESCRIPTION (◆ Indicates Parts Available In Assemblies Only)	Part #	Qty
1	GUARD, LT15 UP/DOWN CHAIN INTERNAL	014907	1
2	BOLT, M16X65-8.8-B HEX HEAD FULL THREAD ZINC	F81006-1	2
3	BOLT, M16X80 8.8-B HEX HEAD FULL THREAD ZINC	F81006-11	2
4	PLATE, UP/DOWN DRIVE SPROCKET MOUNT	087104-1	1
5	SPROCKET, DUAL 17/17	086812-1	1
6	BEARING, R-10	P04156	4
7	NUT, M16 HEX THIN ZINC	F81036-4	2

7

UP/DOWN SYSTEM

Up/Down Drive Sprocket Assembly

8	NUT, M16-8 HEX NYLON ZINC LOCK	F81036-2	4	
9	SPROCKET DUAL 16/17	086813-1	1	
10	WASHER, 41/64"X 1"X 3/16 SPACER	S12480	3	
11	SPROCKET, 17T G1#40-41 5/8" ID	P04333	3	
12	WASHER 17 FLAT ZINC	F81058-1	12	
13	NUT M16-5.8 HEX ZINC	F81036-1	1	
14	NUT, M16-8 HEX NYLON ZINC LOCK	F81036-2	1	
15	GUARD,LT15 UP/DOWN CHAIN SPROCKET	092566-1	2	
16	BOLT, M16X75-8.8-B HEX HEAD FULL THREAD ZINC	F81006-10	1	
17	CHAIN, #40 X 111 1/2"	014831	1	
18	LINK, #40 MASTER	P04200	2	
19	CHAIN, #40 X 14 1/2"	P12496	1	
20	BUSHING - ZINC-PL.	095938-1	2	

7.4 Slide Pads

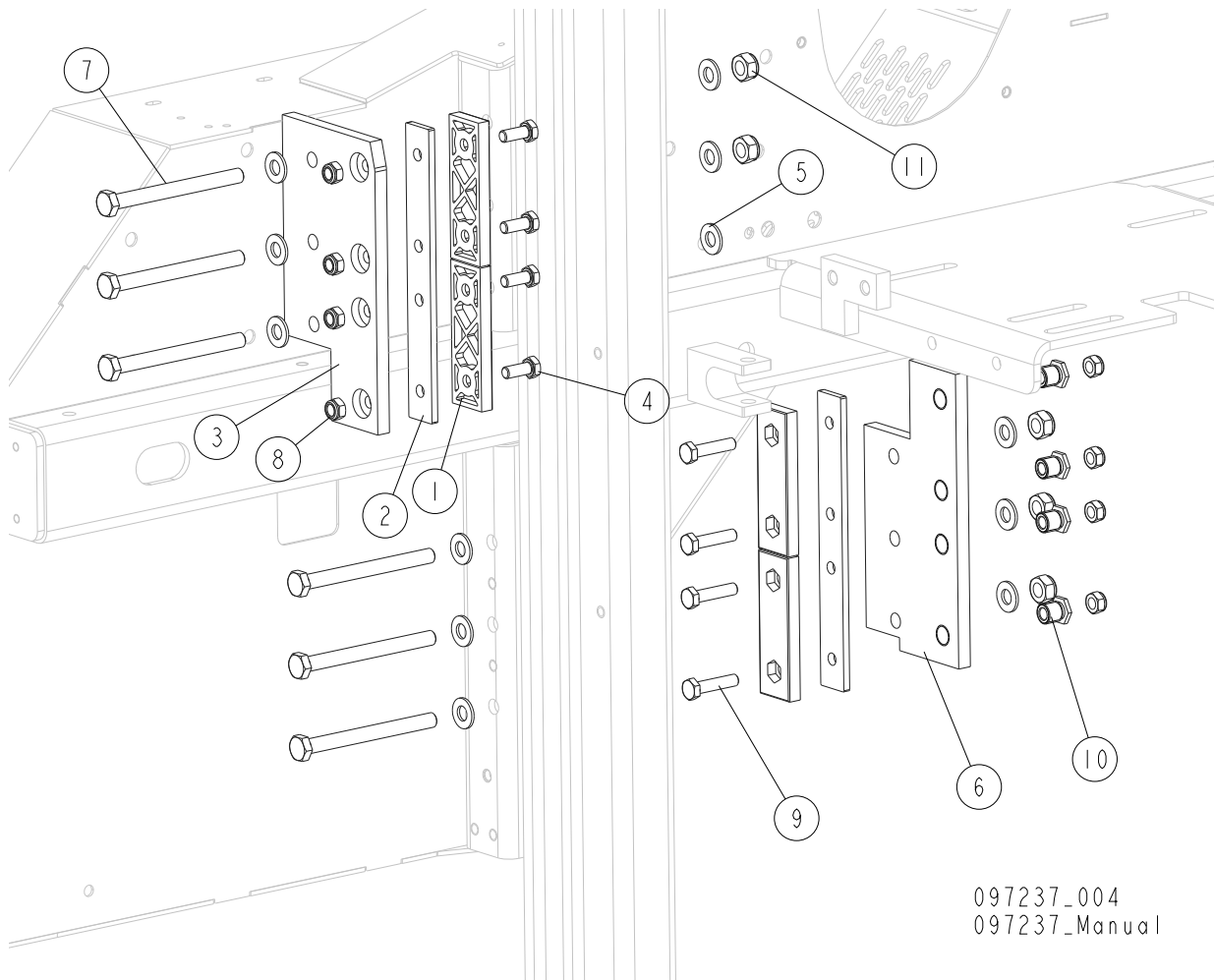

097237_004
097237_Manual

REF.	DESCRIPTION (* Indicates Parts Available In Assemblies Only)	PART #	QTY
1	PADS, DELRIN UP/DOWN SLIDE	M04096	4
2	PLATE, SPACER,SLIDE PAD	094140-1	2
3	PLATE GUIDE UPPER	094139-1	1
4	BOLT, M8X20-8.8-B HEX HEAD FULL THREAD Z	F81002-4	4
5	WASHER, 10.5 FLAT ZINC	F81055-1	12
6	PLATE, SLIDE PAD MOUNT	086682	1
7	BOLT M10X110-8.8-FE/ZN5 PN/M-82101	F81003-43	6
8	NUT, M8-8-B HEX NYLON ZINC LOCK	F81032-2	8
9	BOLT,M8X35-8.8 HEX HEAD FULL THREAD ZINC	F81002-13	4
10	NUT,LT15 SLIDE PAD ADJUSTMENT ZINC-PLATE	086683	1
11	NUT, M10-8-B HEX NYLON ZINC LOCK	F81033-1	5

7.5 Mast Guide

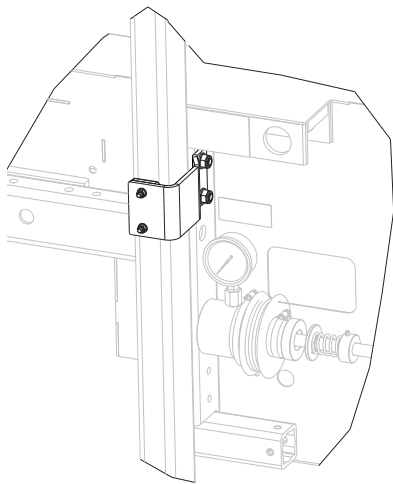

097237_002
097237_Manual

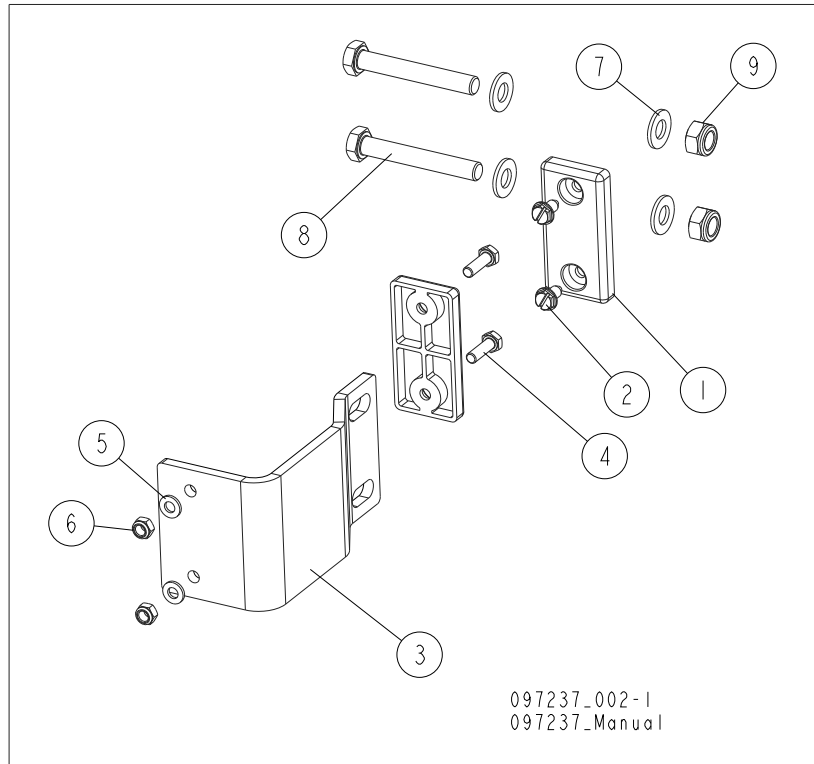

097237_002-1
097237_Manual

REF.	DESCRIPTION (* Indicates Parts Available In Assemblies Only)	PART #	QTY
1	PAD CATAPILLAR TRACK	P13576	2
2	BOLT, 1/4-20 X 1/2 SELF TAP HH	F05015-1	2
3	BRACKET, LT15 MAST GUIDE IDLE SIDE	087192-1	1
4	BOLT, M6X20-8.8 HEX HEAD FULL THREAD ZIN	F81001-2	2
5	WASHER, 6.4 FLAT ZINC	F81053-1	2
6	NUT, M6-8-B HEX NYLON ZINC LOCK	F81031-2	2
7	WASHER, 10.5 FLAT ZINC	F81055-1	4
8	BOLT, M10 X 70-8.8 FE/ZN5, PN-M/82105	F81003-20	2
9	NUT, M10-8-B HEX NYLON ZINC LOCK	F81033-1	2

7.6 Blade Height Scale Indicator

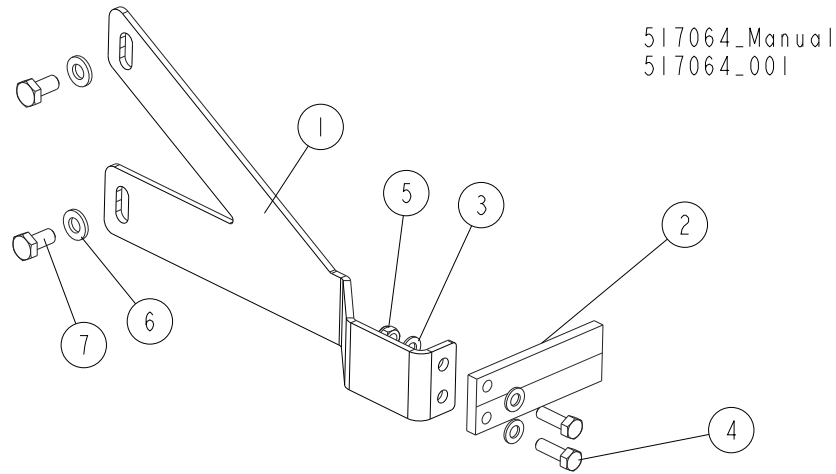

REF.	DESCRIPTION (* Indicates Parts Available In Assemblies Only)	PART #	QTY	
	BLADE HEIGHT SCALE INDICATOR	517064	1	
1	BRACKET, SCALE INDICATOR	517063-1	1	
2	INDICATOR, BLADE HEIGHT SCALE	094821	1	
3	WASHER, 5.3 FLAT ZINC	F81052-1	4	
4	BOLT, M5X16 -8.8- FE/ZN5 HEX HEAD FULL T	F81000-20	2	
5	NUT, M5-8-FE/ZN5 DIN985	F81030-2	2	
6	WASHER, 6.4 FLAT ZINC	F81053-1	2	
7	BOLT, M6X12-8.8 HEX HEAD FULL THREAD ZIN	F81001-7	2	

7.7 Blade Height Scale Bracket

097237_003
097237_Manual

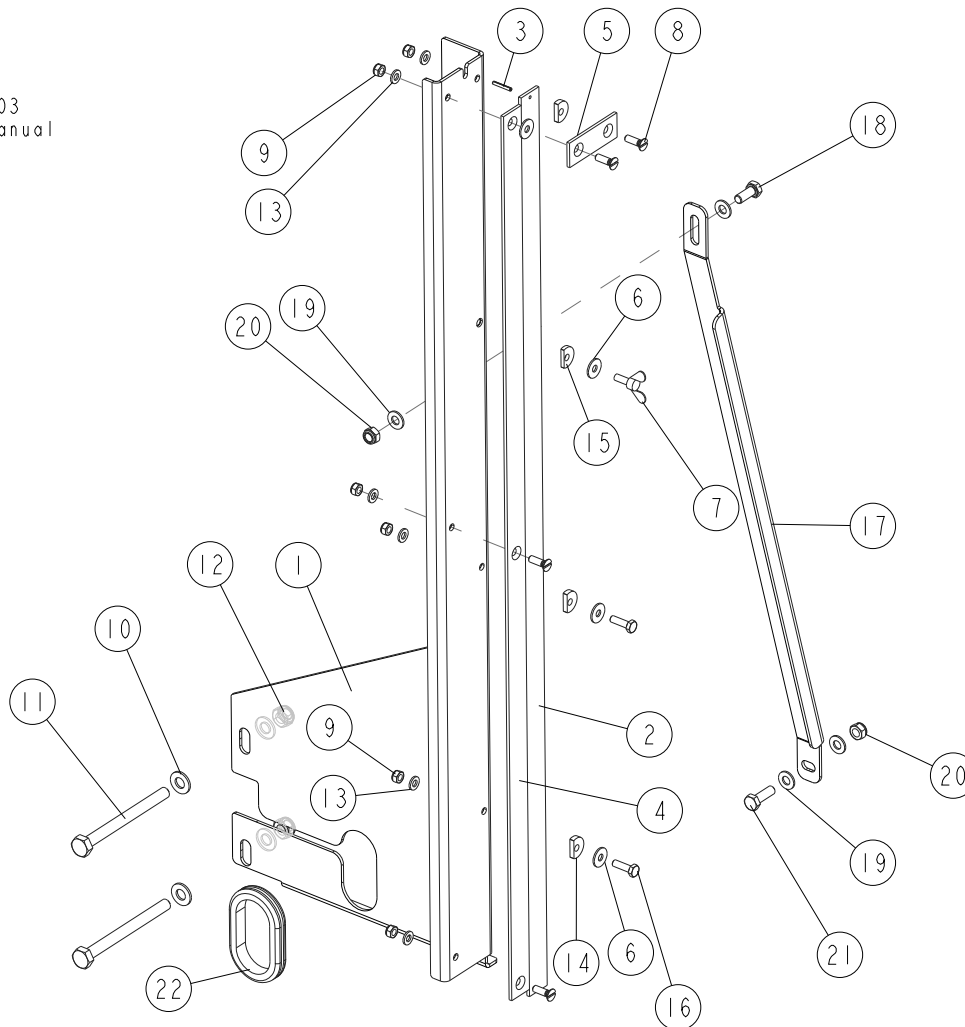

REF.	DESCRIPTION (* Indicates Parts Available In Assemblies Only)	PART #	QTY
	BRACKET, BLADE HEIGHT SCALE COMPLETE	095964	1
1	BRACKET, BLADE HEIGHT SCALE PAINTED	095965-1	1
2	BAR, INCH SCALE	093133	1
3	PIN, 3X20 ROLL ZINC	F81044-5	1
4	BAR, SCALE	092750	1
5	BAR, SCALE MOUNT	093134	1
6	WASHER, FLAT ZINC	F81053-11	4
7	BOLT, M6X16 BN276	F81001-16	1
8	SCREW, M6X20- 4.8-B FE/ZN5 PN-85/M-8220	F81001-31	4
9	NUT, M6-8-B HEX NYLON ZINC LOCK	F81031-2	6
10	WASHER, 10.5 FLAT ZINC	F81055-1	4
11	BOLT, M10 X 115-8.8 FE/ZN5, PN-M/82101	F81003-19	2
12	NUT, M10-8-B HEX NYLON ZINC LOCK	F81033-1	2
13	WASHER, 6.4 FLAT ZINC	F81053-1	6
14	WASHER, SPECIAL 6.2X20X4.5.	503098	3
15	WASHER, SPECIAL 6.2X20X3.5.	503096	1

REF.	DESCRIPTION (* Indicates Parts Available In Assemblies Only)	PART #	QTY	
16	BOLT, M6X20-8.8 HEX HEAD FULL THREAD ZIN	F81001-2	2	
17	BRACKET, SCALE POINTER PTD	094257-1	1	
18	BOLT, M8X20-8.8-B HEX HEAD FULL THREAD Z	F81002-4	1	
19	WASHER, 8.4 FLAT ZINC	F81054-1	4	
20	NUT, M8-8-B HEX NYLON ZINC LOCK	F81032-2	2	
21	BOLT, M8X25-8.8-B HEX HEAD FULL THREAD Z	F81002-5	1	
22	GROMMET, RUBBER	087065	1	

7.8 LT10 Electric Up/Down System (Option)

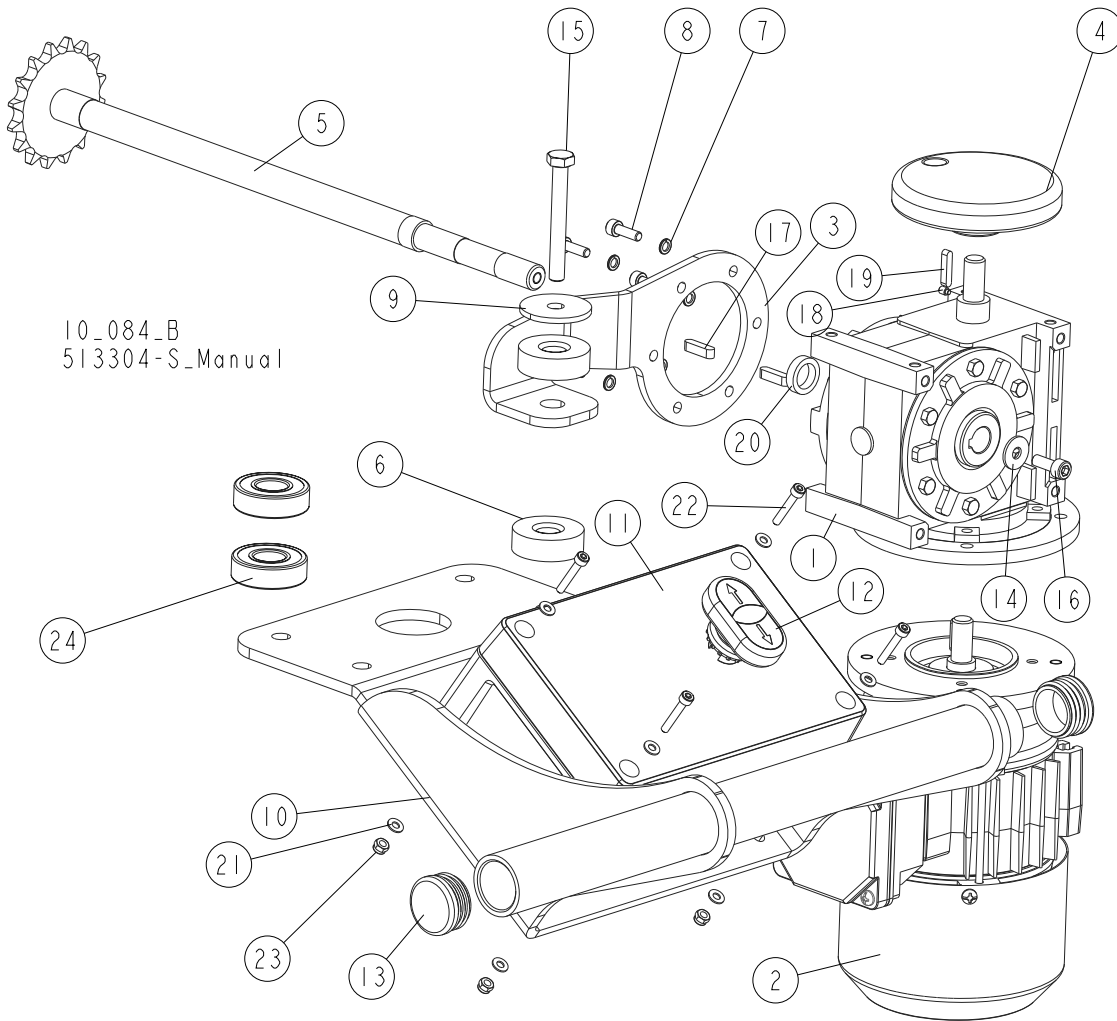

REF.	DESCRIPTION (* Indicates Parts Available In Assemblies Only)	PART #	QTY
	POWER FEED ASSEMBLY, LT10	513304-S	1
	LT10 UP/DOWN SYSTEM	513304	1
	MOTOREDUCER, MRA-03/16/0,18-1400-120/11	513288	1
1	GEARBOX, MRA-03/16/140/11-WBS/KM2/RR/B3	513537	1
2	MOTOR, 0.18-1400-120/11-B	513536	1
3	PLATE, TORQUE ARM	513083-1	1
4	KNOB	513305	1
5	SHAFT WITH SPROCKET	513307 ¹	1
6	WASHER, RUBBER	090443	2
7	WASHER, 5.1 SPLIT LOCK ZINC	F81052-2	6
8	SCREW,M5X16-8.8 HEX SOCKET HEAD CAP ZINC	F81000-25	6
9	WASHER, 5X9X38	513086	1
10	HANDLE WELDMENT, LT10	513302-1	1
11	BOX, LT10 UP/DOWN CONTROL	512942	1
12	BUTTON, M22-DD-S-X7/X7	090917	1

REF.	DESCRIPTION (* Indicates Parts Available In Assemblies Only)	PART #	QTY
13	CAP, BLACK TUBE END	517616	2
14	WASHER, FLAT ZINC	F81053-11	1
15	BOLT, M8 X 65 8.8 FE/ZN5, PN-85/M-82105	F81002-9	1
16	SCREW, M6X16, HEX SOCKET HEAD CAP	F81001-21	1
17	KEY, A5X5X20 PARALLEL	513320	2
18	SCREW, M4x6 ISO4028 SET	F81014-6	1
19	KEY, A4X4X20 PARALLEL	513321	1
20	BUSHING, N14XN20X5 SPACER	513160	1
21	WASHER 4,3 FE/ZN5 PN-M/82005	F81051-2	8
22	BOLT M4 FE/ZN5 PM/M-82302	F81011-3	4
23	NUT M4-B FE/ZN5 PN-M/82175	F81029-1	4
24	BEARING, 6203-2RS	086114 ¹	2

¹ Belongs to 513304-S, not included in 513304.

7.9 Electric Up/Down Control Assembly (Option for CE Version)

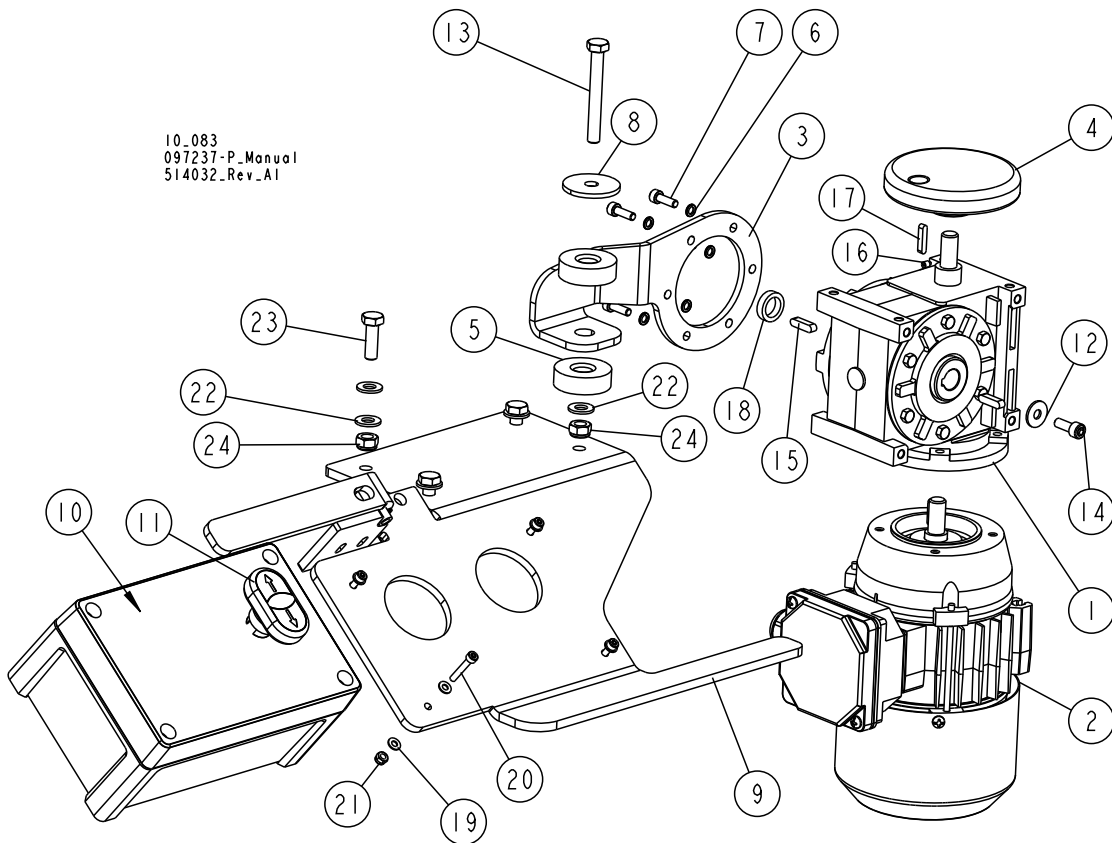

REF.	DESCRIPTION (◆ Indicates Parts Available In Assemblies Only)	PART #	QTY
	CONTROL ASSEMBLY, LT10 ELECTRIC UP/DOWN (CE VERSION)	514032	1
	MOTOREDUCER, MRA-03/16/[0,18-1400-120/11-WBS-B]/KM2/B3	513288	1
1	GEARBOX, MRA-03/16/140/11-WBS/KM2/RR/B3 WORM	513537	1
2	MOTOR, 0.18-1400-120/11-B	513536	1
3	ARM, TORQUE	513083-1	1

7

UP/DOWN SYSTEM*Electric Up/Down Control Assembly (Option for CE Version)*

REF.	DESCRIPTION (◆ Indicates Parts Available In Assemblies Only)	PART #	QTY	
4	KNOB	513305	1	
5	WASHER, RUBBER	090443	2	
6	WASHER, 5.1 SPLIT LOCK ZINC	F81052-2	6	
7	SCREW, M5X16-8.8 HEX SOCKET HEAD CAP ZINC	F81000-25	6	
8	WASHER, 5X9X38	513086	1	
9	HANDLE WELDMENT, LT10	514128-1	1	
10	BOX, LT10 COMPLETE ELECTRIC	512942	1	
11	BUTTON, M22-DD-S-X7/X7	090917	1	
12	WASHER, 6.5 SPECIAL FLAT ZINC	F81053-11	1	
13	BOLT, M8 X 65 8.8 HEX HEAD FULL THREAD ZINC	F81002-9	1	
14	SCREW, M6X16-8.8 HEX SOCKET HEAD CAP ZINC	F81001-21	1	
15	KEY, A5X5X20 PARALLEL	513320	2	
16	SCREW, M4X6 ISO4028 SET	F81014-6	1	
17	KEY, A4X4X20 PARALLEL	513321	1	
18	BUSHING, 14/20-5	513160	1	
19	WASHER, 4.3 FLAT ZINC	F81051-2	8	
20	SCREW, M4X25 8.8 HEX SOCKET HEAD CAP ZINC	F81011-3	4	
21	NUT, M4-B HEX NYLON ZINC LOCK	F81029-1	4	
22	WASHER, 8.4 FLAT ZINC	F81054-1	7	
23	BOLT, M8X25-8.8-B HEX HEAD FULL THREAD ZINC	F81002-5	3	
24	NUT, M8-8-B HEX NYLON ZINC LOCK	F81032-2	4	