



user manual

Instrukcja obsługi | Руководство пользователя
Manuel de l'Utilisateur | Betriebsanweisung
Bruksanvisning | Manual del Usuario
Betjeningsvejledning | Gebruikershandleiding
Käyttöohjeet | Manual de utilizare | Bruksanvisning
Manuale d'uso | Příručka uživatele | Navodila
za uporabo

Retain for future use
Zachować do przyszłego użytku
Сохраните для последующего
использования
A conserver pour une utilisation future
Für zukünftige Benutzung aufbewahren
Behold for senere bruk
Säilytä nämä käyttöohjeet tulevaa tarvetta marten
Opbevar manualen til fremtidig brug
Bewaren voor gebruik in de toekomst
Conservare il presente manuale a l'uso futuro
Păstrați acest manual pentru utilizare viitoare
Conservar para futuras consultas
Behall för framtida användning
Uchovejte pro další použití
Hranite za prihodnjo uporabo

Wood-Mizer®

Sawmill

Safety, Setup, Operation & Maintenance Manual

LT15SA Electric
LT15SA Gasoline

rev.A2.05
rev. A2.06



Safety is our #1 concern! Read and understand all safety information and instructions before operating, setting up or maintaining this machine.

Form #794

**This is the original language
for the manual.**

Table of Contents

Section-Page

SECTION 1	SAFETY	1-1
1.1.	Safety Symbols.....	1-1
1.2	Blade Handling.....	1-2
1.3	Sawmill Setup.....	1-2
1.4	Sawmill Operation.....	1-2
1.5	Sawmill Maintenance	1-4
1.6	Safety Instructions	1-4
1.7	Belt Sizes	1-13
1.8	Blade Sizes	1-13
1.9	Cutting Capacity.....	1-14
1.10	Engine/Motor Specifications.....	1-14
1.11	Noise Level.....	1-14
1.12	Dust Extractor Specifications.....	1-15
1.13	Overall Dimensions	1-16
1.14	Components.....	1-17
SECTION 2	SAWMILL ASSEMBLY	2-1
2.1	Mounting Parts of LT15SA Sawmills with Electric Motors	2-1
2.2	Unpacking the Sawmill	2-6
2.3	Bed Frame Assembly	2-8
2.4	Frame Leg Adjustment.....	2-15
2.5	Saw Head Assembly.....	2-15
2.6	Log Loading Ramp (Option).....	2-20
SECTION 3	SETUP & OPERATION	3-1
3.1	Sawmill Setup.....	3-1
3.2	Replacing The Blade	3-10
3.3	Tensioning The Blade.....	3-11
3.4	Tracking The Blade	3-12
3.5	Starting The Motor	3-16
3.6	Starting The Engine.....	3-16
3.7	Loading, Turning, And Clamping Logs	3-17
3.8	Manual Up/Down Operation	3-21
3.9	Up/Down Operation (Option with Electrical Up/Down System).....	3-22
3.10	Blade Guide Arm Operation.....	3-23
3.11	Blade Drive Operation.....	3-24
3.12	Feed Operation	3-26
3.13	Cutting The Log	3-27
3.14	Edging.....	3-28
3.15	Blade Height Scale	3-28
3.16	Water Lube Operation.....	3-30
3.17	Transporting the Sawmill	3-31

Table of Contents

Section-Page

SECTION 4	MAINTENANCE	4-1
4.1	Wear Life.....	4-1
4.2	Sawdust Removal.....	4-1
4.3	Carriage Track & Rollers.....	4-1
4.4	Vertical Mast Rails.....	4-2
4.5	Miscellaneous Lubrication.....	4-2
4.6	Blade Wheel Belts.....	4-3
4.7	Up/Down System.....	4-3
4.8	Miscellaneous Maintenance.....	4-4
4.9	Filling Blade Tensioner Cylinder with Oil.....	4-5
4.10	Safety Devices Inspection (CE version only).....	4-7
SECTION 5	TROUBLESHOOTING GUIDE	5-1
5.1	Sawing Problems.....	5-1
SECTION 6	SAWMILL ALIGNMENT	6-1
6.1	Pre-Alignment Procedures.....	6-1
6.2	Preparing The Sawmill For Alignment.....	6-1
6.3	Blade Installation and Alignment.....	6-1
6.4	Blade Wheel Alignment.....	6-2
6.5	Blade Guide Arm Alignment.....	6-8
6.6	Aligning The Blade Guides.....	6-9
6.7	Blade Deflection.....	6-10
6.8	Blade Guide Vertical Tilt Adjustment.....	6-11
6.9	Blade Guide Flange Spacing.....	6-13
6.10	Horizontal Tilt Adjustment.....	6-14
6.11	Side Supports.....	6-14
6.12	Blade Height Scale Adjustment.....	6-15
6.13	Motor Drive Belt Adjustment.....	6-17
6.14	Safety Handle Linkage Adjustment.....	6-18
6.15	Track Roller Distance Adjustment.....	6-19
SECTION 7	MOTOR BRAKE	7-1
7.1	Motor Brake Maintenance.....	7-1



IMPORTANT! Read the entire Operator's Manual before operating the sawmill. Take notice of all safety warnings throughout this manual and those posted on the machine. Keep this manual with this machine at all times, regardless of ownership.

Getting Service

Wood-Mizer is committed to providing you with the latest technology, best quality and strongest customer service available on the market today. We continually evaluate our customers' needs to ensure we're meeting current wood-processing demands. Your comments and suggestions are welcome.

General Contact Information

From Europe call your local distributor or our European Headquarters and Manufacturing Facility in Koło, Nagórna 114 St, Poland at **+48-63-2626000**. From the continental U.S., call our U.S. Headquarter 8180 West 10th St. Indianapolis, IN 46214, toll-free at **1-800-525-8100**. Ask to speak with a Customer Service Representative. Please have your machine identification number and your customer number ready when you call. The Service Representative can help you with questions about the operation and maintenance of your machine. He also can schedule you for a service call.

Office Hours:

Country	Monday - Friday	Saturday	Sunday
Poland	7 a.m.- 3 p.m.	Closed	Closed
US	8 a.m.- 5 p.m.	8 a.m.- 12 p.m	Closed

Please have your vehicle identification number and your customer number ready when you call.

Wood-Mizer will accept these methods of payment:

- Visa, Mastercard, or Discover
- COD
- Prepayment
- Net 15 (with approved credit)



Be aware that shipping and handling charges may apply. Handling charges are based on size and quantity of order.

Technical data are subject to change without prior notice.

Actual product may differ from product images. Some illustrations show machines with optional equipment.

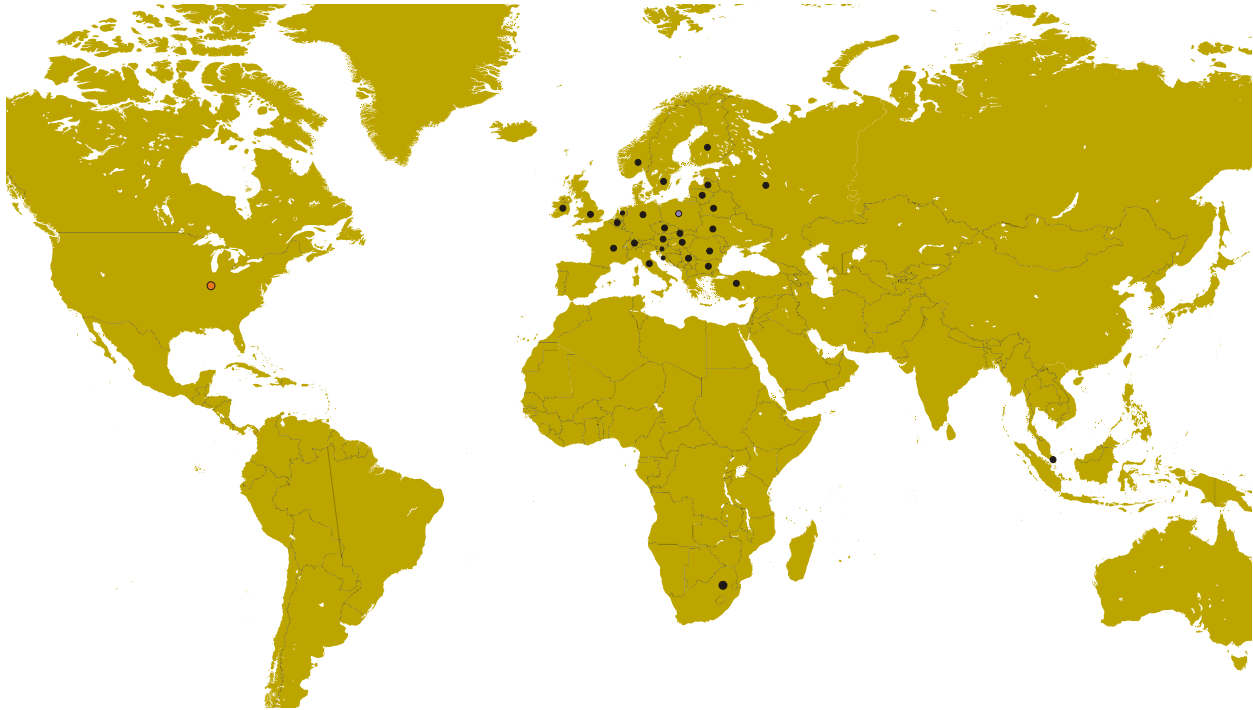
Branches & Authorized Sales Centers Wood-Mizer Locations (North and South America)



EUROPE		UNITED STATES
<p> European Headquarters Wood-Mizer Industries Sp. z o.o. Nagórna 114, 62-600 Kolo, Poland Tel.: +48-63-26-26-000 Fax: +48-63-27-22-327 www.woodmizer.eu</p>		<p> World Headquarters Wood-Mizer LLC 8180 West 10th Street Indianapolis, Indiana 46214-2400, USA Tel.: +1-317-271-1542 Fax: +1-317-273-1011 www.woodmizer.com</p>
<p>BELARUS MOST-GRUPP Siemashko 15, k.3 Minsk 2200116 Tel.: +375-17-270-90-08 Fax: +375-17-270-90-08 GSM: +375-29-649-90-80 e-mail: most-by@mail.ru</p>	<p>SWITZERLAND Stefan Wespi Maschinen u. Geräte Spezialarbeiten GmbH Eichstraße 4 6353 Weggis Tel.: +41-413-900-312 GSM: +41-799-643-594 info@woodmizer.ch www.woodmizer.ch</p>	<p>RUSSIA Dariusz Mikołajewski OOO WOOD-MIZER INDUSTRIES 141031, Moscow Reg., Mytishenski raj., pos. Veshki, Zavodskaja str., 3B Tel.Fax: +7(495) 788-72-35 Tel.Fax: +7(495) 641-51-60 e-mail: dariuszm@woodmizer-moscow.ru</p>
<p>BULGARIA Kalin Simeonov Ecotechproduct 38 Star Lozenski pat str. Sofia 1186 Tel.: +359-2-462-7035 Tel.: +359-2-963-1656 Tel./Fax : +359-2-979-1710 Kalin Simeonov GSM: +3592-963-2559 e-mail: office@ecotechproduct.com</p>	<p>HUNGARY Wiktor Turoczy Wood-Mizer Hungary K.F.T. Szonyi Ut 67., 2921 Komárom Tel./Fax: +36-34-346-255 e-mail: woodmizer@woodmizer.hu</p>	<p>RUSSIA Far East Wladimir Glazaczew "WM Service" Krasnoretchenskaya Str.111 680006 Khabarovsk Tel./Fax: +7-914-541-1183 e-mail: wms-khv@mail.ru</p>

<p>CROATIA Krešimir Pregernik Pregimex d.o.o. S. Batušića 31, 10090 Zagreb Tel./Fax: +3851-38-94-668 Krešimir Pregernik GSM: +3851-98-207-106 e-mail: Kresimir.Pregernik@gmail.com</p>	<p>ITALY Pasquale Felice Wood-Mizer Italia Srl Cda. Capoiaccio SN 86012 Cercemaggiore Campobasso Tel./Fax: +39-0874-798-357 GSM: +39-333-281-03-79 e-mail: wmitaliasrl@gmail.com</p>	<p>SERBIA Dragan Markov Wood-Mizer Balkan d.o.o. Svetosavska GA 3/3; P. Fah 25 23 300 Kikinda Tel./Fax: +381-230-25-754 Tel./Fax: +381-230-23-567 GSM: +381-63-568-658 e-mail: office@woodmizer.co.yu</p>
<p>CZECH REPUBLIC Miroslav Greill Wood-Mizer CZ s.r.o. Za Kasárny 946 339 01 Klatovy Tel: +420-376-312-220 GMS: +420-608-111-104 Miroslav Greill GMS: + 420-602-439-799 E-mail: woodmizer@woodmizer.cz</p>		<p>SLOVAKIA Wiktor Turoczy Wood-Mizer Danubia s.r.o. Hadovce 5, 94501 Komárno Tel.: +421-35-77-40-316 Fax: +421-35-7740-326 GSM: +421-905-930-972 e-mail: woodmizer@woodmizer.sk</p>
<p>CZECH REPUBLIC Lubomir Kudlik Wood-Mizer Moravia Sovadinova 6 69002 Breclav Tel./Fax: +420-519-322-443 Lubomir Kudlik GSM: +420-602-734-792 e-mail: info@wood-mizer.net</p>	<p>LATVIA Vilmars Jansons OBERTS Ltd Gaujas str. 32/2 LV-2167 Marupe, Rigas Raj. Tel.: +371-7-810-666 Fax: +371-7-810-655 Vilmars Jansons GSM: +371-92-06-966 Andris Orols GSM: +371-28-33-07-90 e-mail: andris@oberts.lv</p>	<p>TURKEY Er-Ka Ahsap Profil Kerestecilik San. ve Tic. Ltd. Sti. Adana Keresteciler Sitesi 191 sk No.41 ADANA Tel.: +90-322-346-15-86 Fax: +90-322-345-17-07 GSM: +90-533-363-18-44 e-mail: info@erkaahsap.com.tr</p>
<p>FINLAND Howard Blackbourn Oy Falkberg Jordbruk Ab Falkintie 220 25610 Ylonkyla Tel.: +358-2732-2253 Fax: +358-2732-2263 Howard Blackbourn GSM: +358-440-424-339 e-mail: falkberg@woodmizer.fi</p>	<p>LITHUANIA Andrius Zuzevicius UAB Singlis Savanoriu pr. 187, 2053 Vilnius Tel.: +370-5-2-32-22-44 Fax: +370-5-2-64-84-15 GSM: +370-620-28-645 e-mail: andrius.z@singlis.lt Dmitrij Gaiduk GSM: +370-69-84-51-91 e-mail: dmitrijus.g@singlis.lt</p>	<p>UKRAINE Ivan Vinnicki MOST UKRAINA bul. Myru 3, Bajkivtsi Ternoplskyj r-j Ternopolska oblast 47711 Ukraine Tel/Fax: +38 (0352) 52 37 74 GSM: +38 (067) 352 54 34 GSM: +38 (067) 674 50 68 E-mail: most-ukraine@ukr.net</p>
<p>FRANCE Tizoc Chavez Wood-Mizer France 556 chemin des Embouffus, ZAC des Basses Echarrieres 38440 SAINT JEAN DE BOURNAY Tel: +33-4 74 84 84 44 GSM: +33-607 52 02 82 Mail: tchavez@woodmizer.fr</p>	<p>NORWAY Tor Bakken Flaathe Bakken Flaathe A/S Løkenvegen 5, 2034 Holter Tel: + 47-638 74 989 Sales: + 47- 412 80 076 Service: +47- 975 87 588 post@woodmizer.no www.woodmizer.no</p>	<p>UNITED KINGDOM & IRELAND Wood-Mizer UK Hopfield Barn Kenward Road, Yalding Kent ME18 6JP, UK Tel.: +44-1622-813-201 Fax: +44-1622-815-534 e-mail: info@woodmizer.co.uk</p>
<p>SLOVENIA Jan Fale FAMTEH d.o.o. Gacnikova pot 2, 2390 Ravne na Koroskem Tel.: +386-2-62-04-232 Fax: +386-2-62-04-231 Jan Fale GSM: +386-2-62-04-230 e-mail: jan.fale@famteh.si Matjaz Kolar Tel.: +386-2-62-04-232 GSM: +386-31-775-999 e-mail: matjaz.kolar@famteh.si</p>		

<p>GERMANY/AUSTRIA Klaus Longmuss Wood-Mizer GmbH Dorfstraße 5, 29485 Schletau Büro Tel: +49-5883 988 010 Werkstatt Tel: +49-5883 988 220 Ersatzteilservice Tel: +49 58 83 - 98 80 250 Schärfservice Tel: +49-58 83 - 98 80 270 E-mail: info@woodmizer.de www.woodmizer.de Klaus Longmuss Tel.: +49-5883-9880-12 GSM: +49-17-298-55-892 e-mail: KLongmuss@woodmizer.de</p>	<p>Subagent: SWEDEN Kjell Larsson Mekwood AB Slingan 14, 812 41 Gästrike-Hammarby Tel.: +46-290-515-65 Kjell Larsson GSM: +46-706-797-965 e-mail: kjell.larsson@mekwood.se</p>	<p>IRELAND Wood-Mizer Ireland Stephen Brennan Cum Lahardane Ballina County Mayo Tel:+353 96 51345 E-mail: brennanmill@ericom.net</p>
<p>Subagents: DENMARK Kevin Christiansen Kevin Christiansen's savværker PMV Arnborgvej 40, 7330 Brande- Fasterholt Mobile: +45 61468763 Mobile: +45-23495828 Info@woodmizer.dk www.woodmizer.dk</p>	<p>ROMANIA Adrian Echert SC WOOD-MIZER RO SRL TRANSILVANIEI Nr. 5 Sibiu, Cisanadie 555300 Tel./Fax: : +40-369-405-433 GSM: +40-745-707-323 e-mail: aechert@woodmizer.ro</p>	<p>Regional Manager - Asia Robert Moxham Regional Direction - Asia Wood-Mizer Asia Manufacturing Co., Ltd. No.2, Gongyequ 40th Rd. Xitun District, Taichung City, 40768, Taiwan, R.O.C. TEL: +886-4-2359 3022 FAX: +886-4-2359 3205 CELL: +886-9-0568 7708 EMAIL: RMoxham@woodmizer.com www.woodmizerasia.com Skype: r.g.moxham</p>
<p>NETHERLANDS Gerlo Breukers Breukers Houtzagerij en Bosbouwmachines Hazenweg 5, 7481 PC Haaksbergen Tel: +31-535741326 Mobile: +31-620419412 info@woodmizer.nl www.woodmizer.nl</p>	<p>Subagent: ROMANIA M. Echert S.C. Echert Comprod s.r.l Str. Schitului Nr. 6, Apt.7 etajul-1 725 70 Vatra Dornei, Romania Tel./Fax: +40-230-374-235 Tel. : +40-740-35-35-74</p>	<p>Regional Manager - Africa Gavin Prowse Regional Sales Director - Africa Wood-Mizer Africa (Pty) Ltd. Unit 1, Leader Park 20 Chariot Street Stormill Ext.5 Maraisburg, Johannesburg South Africa TEL: +27 11 473 1313 FAX: +27 11 473 2005 CELL: +27 71 398 8010 EMAIL: growse@woodmizer.com www.woodmizerafrika.com Skype: gavin.prowse</p>

USA World Headquarters

Serving North & South America, Oceania, East Asia

Wood-Mizer LLC
8180 West 10th Street
Indianapolis, IN 46214

Phone: 317.271.1542 or 800.553.0182
Customer Service: 800.525.8100
Fax: 317.273.1011
Email: infocenter@woodmizer.com

Brazil Headquarters

Serving Brazil

Wood-Mizer do Brasil
Rua Dom Pedro 1, No: 205 Bairro: Sao Jose
Ivoti/RS CEP:93.900-000

Tel: +55 51 9894-6461/ +55 21 8030-3338/ +55 51 3563-4784
Email: info@woodmizer.com.br

Canadian Headquarters

Serving Canada

Wood-Mizer Canada
396 County Road 36, Unit B
Lindsay, ON K9V 4R3

Phone: 705.878.5255 or 877.357.3373
Fax: 705.878.5355
Email: ContactCanada@woodmizer.com

Europe Headquarters

Serving Europe, Africa, West Asia

Wood-Mizer Industries Sp z o.o.
Nagorna 114
62-600 Kolo, Poland

Phone: +48.63.26.26.000
Fax: +48.63.27.22.327

Branches & Authorized Sales Centers

For a complete list of dealers, visit www.woodmizer.com

SECTION 1 SAFETY

1.1. Safety Symbols

This symbol calls your attention to instructions concerning your personal safety. Be sure to observe and follow these instructions.



The word **DANGER** indicates an imminently hazardous situation which, if not avoided, will result in death or serious injury.



WARNING suggests a potentially hazardous situation which, if not avoided, could result in death or serious injury.



CAUTION refers to potentially hazardous situations which, if not avoided, may result in minor or moderate injury to persons or equipment.



Warning stripes are placed on areas where a single decal would be insufficient. To avoid serious injury, keep out of the path of any equipment marked with warning stripes.

Read and observe all safety instructions before operating this equipment! Also read any additional manufacturer's manuals and observe any applicable safety instructions including dangers, warnings, and cautions.

Always be sure that all safety decals are clean and readable. Replace all damaged safety decals to prevent personal injury or damage to the equipment. Contact your local distributor, or call your Customer Service Representative to order more decals.

IMPORTANT! It is always the owner's responsibility to comply with all applicable federal, state and local laws, rules and regulations regarding the ownership, operation and towing of your Wood-Mizer sawmill. All Wood-Mizer mill owners are encouraged to become thoroughly familiar with these applicable laws and comply with them fully while using the mill.

Always properly dispose of all sawing by-products, including sawdust and other debris, coolant, oil, fuel, oil filters and fuel filters.

Safety instructions are listed in this section by the following operations:

- Blade Handling,
- Sawmill Setup
- Sawmill Operation
- Sawmill Maintenance

1.2 Blade Handling

 **DANGER!** Always disengage the blade and shut off the sawmill engine before changing the blade. Failure to do so will result in serious injury.

 **WARNING!** Always wear gloves and eye protection when handling bandsaw blades. Changing blades is safest when done by one person! Keep all other persons away from area when coiling, carrying or changing a blade. Failure to do so may result in serious injury.

1.3 Sawmill Setup

 **WARNING!** Do not set up the mill on ground with more than a 10 degree incline. If setup on an incline is necessary, put blocks under one side of the mill or dig out areas for the legs to keep mill level. Setting up the mill on an incline could cause it to tip over, resulting in serious personal injury.

WARNING! Keep all persons out of the path of the saw head while loading and unloading the sawmill. Failure to do so may result in serious injury or death.

1.4 Sawmill Operation

 **IMPORTANT!** The sawmill is intended for sawing wood only. [See Section 1.9](#) for log size capacities of the machine.

IMPORTANT! The operator of the sawmill should get adequate training in the operation and adjustment of the machine.

 **DANGER!** Make sure all guards and covers are in place and secured before operating or towing the sawmill. Failure to do so may result in serious injury.

DANGER! Be sure the blade housing cover is in place and secured. Do not open the blade housing when the blade is engaged.

DANGER! Always keep hands away from moving bandsaw blade. Failure to do so may result in serious injury.

DANGER! Keep all persons out of the path of moving equipment and logs when operating sawmill or loading and turning logs. Failure to do so may result in serious injury.

DANGER! Maintain a clean and clear path for all necessary movement around the mill and lumber stacking areas. Failure to do so may result in serious injury.

 **WARNING!** Always wear eye, ear, respiration and foot protection as well as safety clothing when operating the sawmill. Failure to do so may result in serious injury.

WARNING! Secure all loose clothing and jewelry before operating the sawmill. Failure to do so will result in serious injury or death.

WARNING! Always make sure log is clamped securely before sawing. Failure to do so will result in serious injury or death.

WARNING! Use ONLY water or alcohol solution with the water lube accessory. Never use flammable fuels or liquids. If these types of liquids are necessary to clean the blade, remove it and clean with a rag. Failure to do so will result in serious injury or death.

 **CAUTION!** Be sure the log clamps are all the way down before loading a log onto the bed. Failure to do so may result in machine damage.

CAUTION! Before loading a log, be sure the cutting head is moved far enough forward so the log does not hit it. Failure to do so may result in machine damage.

CAUTION! Do not try to force the saw head beyond its upper and lower travel limits. Damage to the up/down system may result.

CAUTION! Be sure to stop the blade when returning the carriage. This will not only prevent the blade from being pulled off and ruined by a wood sliver, but also will increase the life of the blade.

CAUTION! Remove the optional loading ramps before sawing.

 **CAUTION!** Never clean the blade or the blade wheels with a brush or a scraper during sawmill operation.

CAUTION! Before installation of the blade, inspect it for damage and cracks. Use only properly sharpened blades. Always handle the blade with extreme caution. Use suitable carrier equipment for transporting the blades.

CAUTION! Always wear gloves when handling the blade. Never grab the blade with bare hands!

CAUTION! If the blade breaks during sawmill operation, push the EMERGENCY STOP button to stop the blade motor and wait 10 seconds before you open the blade housing cover.

CAUTION! The sawmill's work-stand should be equipped with a 4 kg or bigger dry powder extinguisher.

1.5 Sawmill Maintenance

 **CAUTION!** Reinstall the track wiper so that it lightly touches the track bar. If the wiper presses too firmly against the bar, it can cause the power feed to bind.

CAUTION! Never use grease on the mast rails as it will collect sawdust.

Always be sure that all safety decals are clean and readable. Replace all damaged safety decals to prevent personal injury or damage to the equipment. Contact your local distributor, or call your Customer Service Representative to order more decals.

1.6 Safety Instructions

 **IMPORTANT!** The sawmill is intended for sawing wood only. The sawmill must not be used for other purposes such as cutting ice, metal or any other materials. [See Section 1.9](#) for log size capacities of the machine.

IMPORTANT! The operator of the sawmill should get adequate training in the operation and adjustment of the machine.

NOTE: ONLY safety instructions regarding personal injury are listed in this section. Caution statements regarding only equipment damage appear where applicable throughout the manual.

Observe Safety Instructions

 **IMPORTANT!** Read the entire Operator's Manual before operating the sawmill. Take notice of all safety warnings throughout this manual and those posted on the machine. Keep this manual with this machine at all times, regardless of ownership.

Also read any additional manufacturer's manuals and observe any applicable safety instructions including dangers, warnings, and cautions.

Only adult persons who have read and understood the entire operator's manual should operate the sawmill. The sawmill is not intended for use by or around children.

IMPORTANT! It is always the owner's responsibility to comply with all applicable federal, state and local laws, rules and regulations regarding the ownership and operation of your Wood-Mizer sawmill. All Wood-Mizer sawmill owners are encouraged to become thoroughly familiar with these applicable laws and comply with them fully while using the machine.



Wear Safety Clothing



WARNING! Secure all loose clothing and jewelry before operating the sawmill. Failure to do so may result in serious injury or death.

WARNING! Always wear gloves and eye protection when handling bandsaw blades. Changing blades is safest when done by one person! Keep all other persons away from area when coiling, carrying or changing a blade. Failure to do so may result in serious injury.

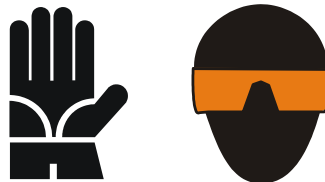

WARNING! Always wear eye, ear, respiration, and foot protection when operating or servicing the sawmill.



Keep sawmill And Area Around sawmill Clean



DANGER! Maintain a clean and clear path for all necessary movement around the sawmill and lumber stacking areas. Failure to do so will result in serious injury.

Dispose Of Sawing By-Products Properly



IMPORTANT! Always properly dispose of all sawing by-products, including sawdust and other debris.

Check sawmill Before Operation



DANGER! Make sure all guards and covers are in place and secured before operating the sawmill. Failure to do so may result in serious injury.



Keep Persons Away



DANGER! Keep all persons out of the path of moving equipment and lumber when operating the sawmill. Failure to do so will result in serious injury.

DANGER! Always be sure all persons are out of the path of the blade before starting the motor. Failure to do so will result in serious injury.



WARNING! Allow blade to come to a complete stop before opening the blade housing cover. Failure to do so will result in serious injury.

Keep Hands Away



DANGER! Always shut off the blade motor before changing the blade. Failure to do so will result in serious injury.

DANGER! Motor components can become very hot during operation. Avoid contact with any part of a hot motor. Contact with hot motor components can cause serious burns. Therefore, never touch or perform service functions on a hot motor. Allow the motor to cool sufficiently before beginning any service function.

DANGER! Always keep hands away from moving bandsaw blade. Failure to do so will result in serious injury.

DANGER! Always be aware of and take proper protective measures against rotating shafts, pulleys, fans, etc. Always stay a safe distance from rotating members and make sure that loose clothing or long hair does not engage rotating members resulting in possible injury.

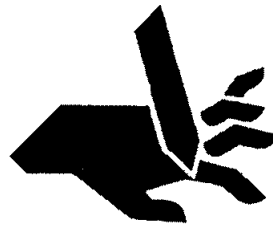

WARNING! Use extreme caution when spinning the blade wheels by hand. Make sure hands are clear of blade and wheel spokes before spinning. Failure to do so may result in serious injury.

Use Proper Maintenance Procedures



DANGER! Make sure all electrical installation, service and/or maintenance work is performed by a qualified electrician and is in accordance with applicable electrical codes.

DANGER! Hazardous voltage inside the electric boxes and at the motor can cause shock, burns, or death. Disconnect and lock out power supply before servicing! Keep all electrical component covers closed and securely fastened during sawmill operation.



WARNING! Consider all electrical circuits energized and dangerous.

WARNING! Disconnect and lock out power supply before servicing the sawmill! Failure to do so may result in serious injury.

WARNING! Never assume or take the word of another person that the power is off; check it out and lock it out.

WARNING! Do not wear rings, watches, or other jewelry while working around an open electrical circuit.

WARNING! Remove the blade before performing any service to the motor or sawmill. Failure to do so may result in serious injury.

DANGER! Never clean the blade or blade wheels using the hand-held brush or scraper whilst the sawmill blade is in motion.

CAUTION! Before installation of the blade, inspect it for damage and cracks. Use only properly sharpened blades. Always handle the blade

with extreme caution. Use suitable carrier equipment for transporting the blades.

CAUTION! Always wear gloves when handling the blade. Never grab the blade with bare hands!

CAUTION! If the blade breaks during sawmill operation, push the EMERGENCY STOP button to stop the blade motor and wait 10 seconds before you open the blade housing cover.

CAUTION! The sawmill's work-stand should be equipped with a 4 kg or bigger dry powder extinguisher.

Keep Safety Labels In Good Condition



IMPORTANT! Always be sure that all safety decals are clean and readable. Replace all damaged safety decals to prevent personal injury or damage to the equipment. Contact your local distributor, or call your Customer Service Representative to order more decals.



IMPORTANT! If replacing a component which has a safety decal affixed to it, make sure the new component also has the safety decal affixed.

See **Table 1-1**. Pictogram decals used to warn and inform the user about danger in the LT15SA.

TABLE 1-1

Decal View	W-M No.	Description
	096317	CAUTION! Read thoroughly the manual before operating the machine. Observe all safety instructions and rules when operating the sawmill.

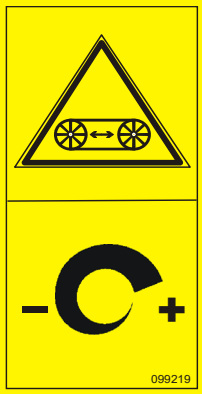
TABLE 1-1

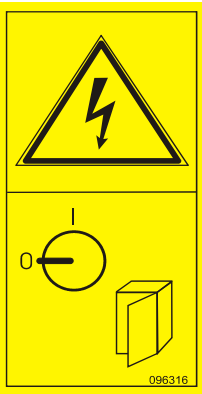
	<p>099220</p>	<p>CAUTION! Close all guards and covers before starting the machine.</p>
	<p>099219</p>	<p>Blade tension. Turning the bolt clockwise will increase the blade tension and turning the bolt counterclockwise will decrease the tension.</p>
	<p>099221</p>	<p>CAUTION! Keep all persons a safe distance away from work area when operating the machine.</p>
	<p>096316</p>	<p>CAUTION! Do not open or close the electric box when the switch is not in the "0" position.</p>

1

Safety

Keep Safety Labels In Good Condition

TABLE 1-1







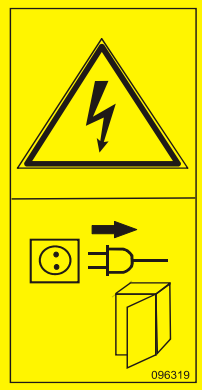

	<p>096319</p>	<p>CAUTION! Disconnect power supply before opening the box.</p>
	<p>096321</p>	<p>Blade movement direction</p>
	<p>S12004G</p>	<p>CAUTION! Always wear safety goggles when operating the sawmill!</p>
	<p>S12005G</p>	<p>CAUTION! Always wear protective ear muffs when operating the sawmill!</p>

TABLE 1-1

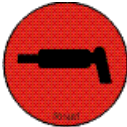
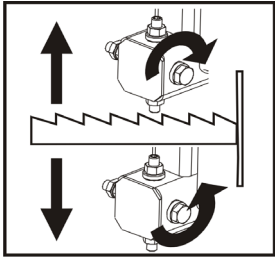
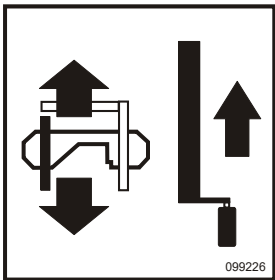

	501465	CAUTION! Always wear safety boots when operating the sawmill!																						
	501467	Lubrication Point																						
 <p style="text-align: right; font-size: small;">P11789b</p>	P11789	Aligning the blade on the wheels																						
 <p style="text-align: right; font-size: small;">099226</p>	099226	Power feed system engagement																						
<table border="1" style="margin: auto; border-collapse: collapse; text-align: center;"> <thead> <tr style="background-color: #ffff00;"> <th rowspan="2">Type</th> <th colspan="2"></th> <th rowspan="2">psi</th> <th rowspan="2">bar</th> </tr> <tr style="background-color: #ffff00;"> <th>F[mm]</th> <th>E[mm]</th> </tr> </thead> <tbody> <tr style="background-color: #ffff00;"> <td>275</td> <td>1,07</td> <td>32</td> <td>1015-1088</td> <td>70-75</td> </tr> <tr style="background-color: #ffff00;"> <td>375</td> <td>1,14</td> <td>32</td> <td>1088-1160</td> <td>75-80</td> </tr> <tr style="background-color: #ffff00;"> <td>2735</td> <td>1,07</td> <td>35</td> <td>1160-1233</td> <td>80-85</td> </tr> </tbody> </table>	Type			psi	bar	F[mm]	E[mm]	275	1,07	32	1015-1088	70-75	375	1,14	32	1088-1160	75-80	2735	1,07	35	1160-1233	80-85	510643	Setting the blade tension indicator
Type						psi	bar																	
	F[mm]	E[mm]																						
275	1,07	32	1015-1088	70-75																				
375	1,14	32	1088-1160	75-80																				
2735	1,07	35	1160-1233	80-85																				

1

Safety

Keep Safety Labels In Good Condition

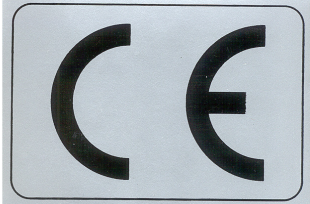
TABLE 1-1

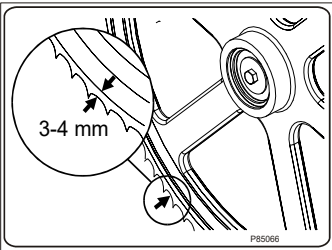
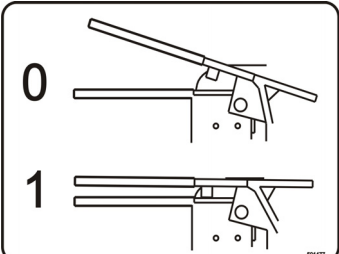
	<p>P85070</p>	<p>CE safety certification</p>
	<p>099401</p>	<p>Russian safety certification</p>
	<p>S20097F</p>	<p>2925 r.p.m. - motor rotation direction</p>
	<p>P85066</p>	<p>Blade positioning</p>
	<p>501477</p>	<p>Safety handle. The blade is stopped when the handle is released.</p>

1.7 Belt Sizes

See Table 1-2. Belt sizes for the LT15SA are shown.

Description	Belt Size	Wood-Mizer Part #
Motor Drive Belt E7.5	B81	014819
Engine Drive Belt G14	BX87	097448
Blade Pulley Belts	B57 ¹	P04185

TABLE 1-2

¹ To insure proper blade tracking, use Goodyear, Dayco Super II, or Browning belts only.

1.8 Blade Sizes

See Table 1-3. Wood-Mizer TRU•SHARP™ offers three types of blades to provide efficient sawing for all models of sawmills. The engine/motor size of your sawmill and the type of wood you saw should determine which blade you choose for optimum performance.

Engine/Motor Size	Recommended Blade For Sawing ³ :		
	Softwood	Hardwood	Frozen or Hard-to-Cut Wood
5 hp - 15hp	B275IH1030 B275IH741030	B375IH929	B375IH929 ¹
16hp or more	B376IH1030 B376IH741030	B275IH1030 B275IH741030 B376IH1030 B376IH741030 ²	B375IH929 ¹
Electric Motor	B376IH1030 B376IH741030	B275IH1030 B275IH741030 B376IH1030 B376IH741030 ²	B375IH929 ¹

TABLE 1-3

¹ TRU•SHARP™ “F” blades use a 9/29 profile (9° hook angle and 29° back angle) and are designed to cut frozen and/or extremely dense, hard-to-cut wood.

Standard TRU•SHARP™ blades use a 10/30 profile.

² Customer may choose preferred blade.

³ LT15SA Sawmill is equipped with a blade with a length of 4.01 m.

See *The Blade Handbook* for blade hook angle, tooth height, and tooth set specifications.

1.9 Cutting Capacity

See Table 1-4. The log size capacities of the LT15SA sawmills are listed below.

	Max. Diameter	Max. Length ¹
LT15SA S3	70 cm	5,4 m
LT15SA S4	70 cm	7,3 m

TABLE 1-4

¹ Each additional bed frame segment adds approximately 195 cm (6' 5") to length capacity.

1.10 Engine/Motor Specifications

See Table 1-5. The power options available for the LT15SA sawmill are listed below.

Engine/Motor Type	Manufacturer	Model Number	Specifications
5.5 kW Motor	Indukta, Poland	PSg-132S-2A	3 x 400V, 50 Hz 2920 r.p.m.
7.5 kW Motor	Indukta, Poland	PSg-132S-2B	3 x 400V, 50 Hz 2910 r.p.m.
11 kW Motor	Indukta, Poland	PSg-132M-2A	3 x 400V, 50 Hz 2920 r.p.m.
G14 Gasoline Engine	Kohler, USA	Command PRO CH440	429cm ³ , 14HP (10.5kW) 30.8Nm 3600 r.p.m.

TABLE 1-5

1.11 Noise Level

See Table 1-6. The average level of noise is given in table below¹².

	Noise Level
LT15SAE7,5	83,3 dB (A)
LT15SAG14	94dB (A)

TABLE 1-6

1. The noise level measurement was taken in accordance with PN-EN ISO 3746 Standard. The noise exposure level given above concerns an 8-hour work day. Value for associated uncertainty K=4dB.
2. The figures quoted are emission levels and are not necessarily safe working levels. Whilst there is a correlation between the emission and exposure levels, this cannot be used reliably to determine whether or not further precautions are required. Factors that influence the actual level of exposure of the workforce include the characteristics of the work room and the other sources of noise etc. i.e. the number of machines and other adjacent processes. Also the permissible exposure level can vary from country to country. This information, however, will enable the user of the machine to make a better evaluation of the hazard and risk.

1.12 Dust Extractor Specifications

See **Table 1-7**. Specifications of the dust extractors used on the resaw for each saw head are listed below.¹

Airflow	1200 m ³ /h 3937ft ³ /h
Inlet diameter	100 mm (5.9")
Motor power	1.5 kW
Number of sacks	1 pcs
Sack capacity	0,25 m ³ (8.8 ft) ³
Weight	110 kg (242.5 lb)
Pressure drop	1.5 kPa (0.22 psi) ¹
Recommended conveying air velocity in the duct	20 m/s 65.6 ft/s

TABLE 1-7

¹ The pressure drop between the inlet of the capture device and the connection to the CADES should be maximum 1.5 kPa (for the nominal air flow rate). If the pressure drop exceeds 1.5 kPa the machine might not be compatible with conventional CADES.



IMPORTANT! The dust extractor hoses must be grounded or made with materials not accumulating electrostatic charge.



CAUTION! Always turn on the dust extractor before starting the machine



IMPORTANT! The total value of hand-arm vibration the operator may be exposed to does not exceed 2.5 m/s². The highest root mean square value of weighted acceleration to which the whole operator's body is subjected does not exceed 0.5 m/s².

1. External chip and dust extraction equipment with fixed installations are dealt with in EN 12779:2016-04.

1.13 Overall Dimensions

See Figure 1-1. The overall dimensions of the LT15SA sawmills are shown below.

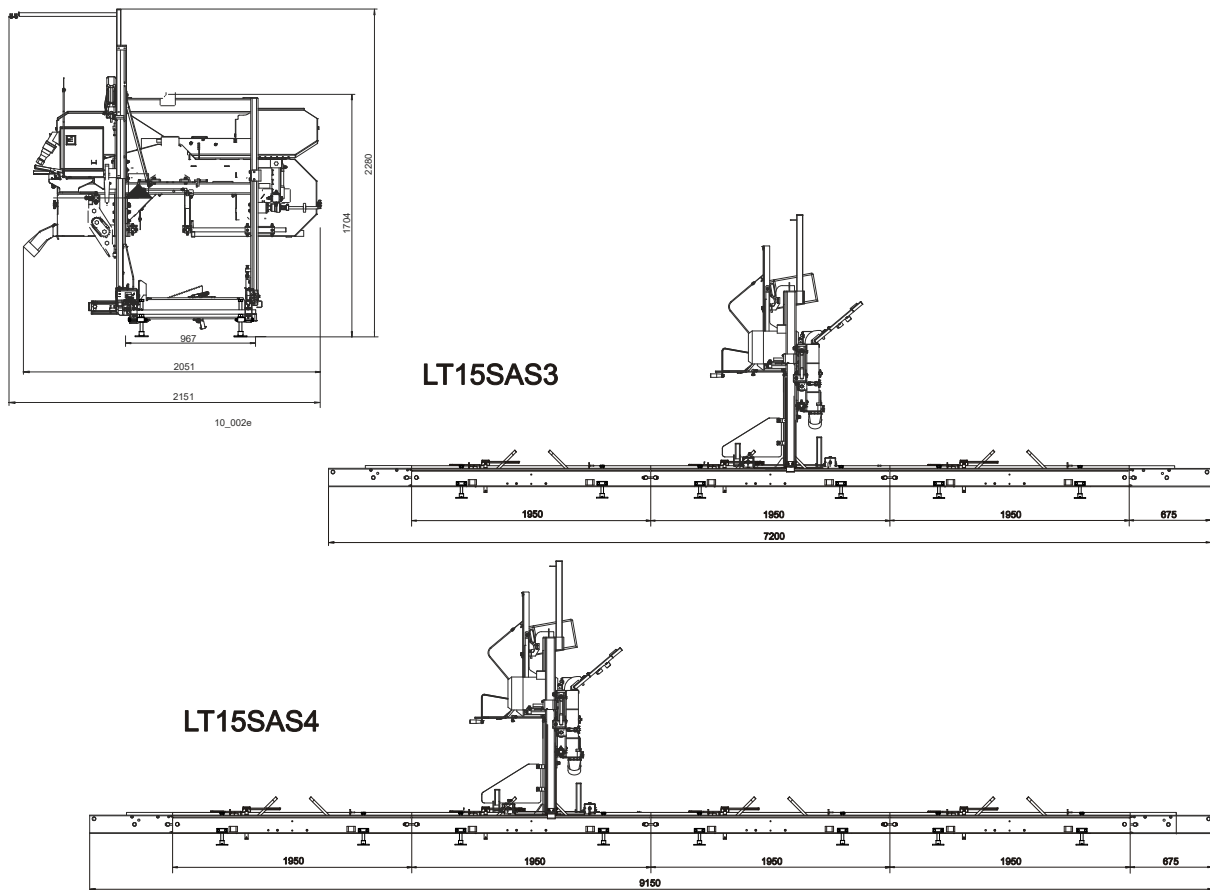

FIG. 1-1

See Figure 1-2. See the figure below for the operator's work-place.

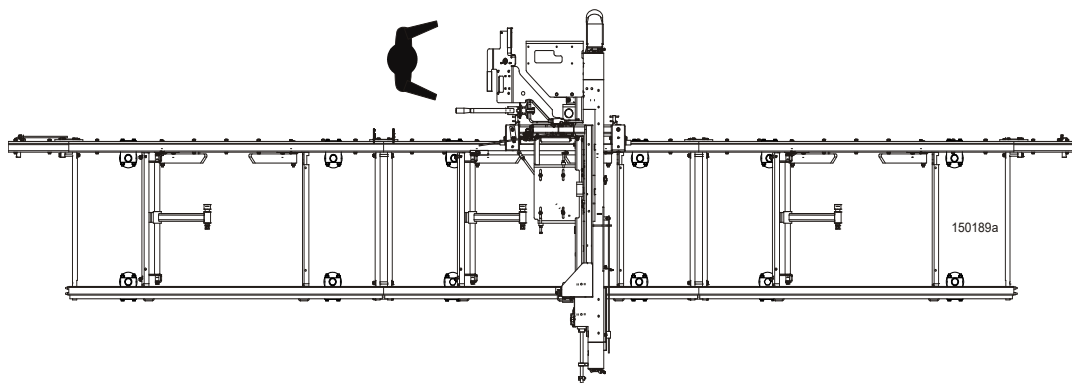

FIG. 1-2

1.14 Components

See Figure 1-3. The major components of the Wood-Mizer LT15SA are shown below.

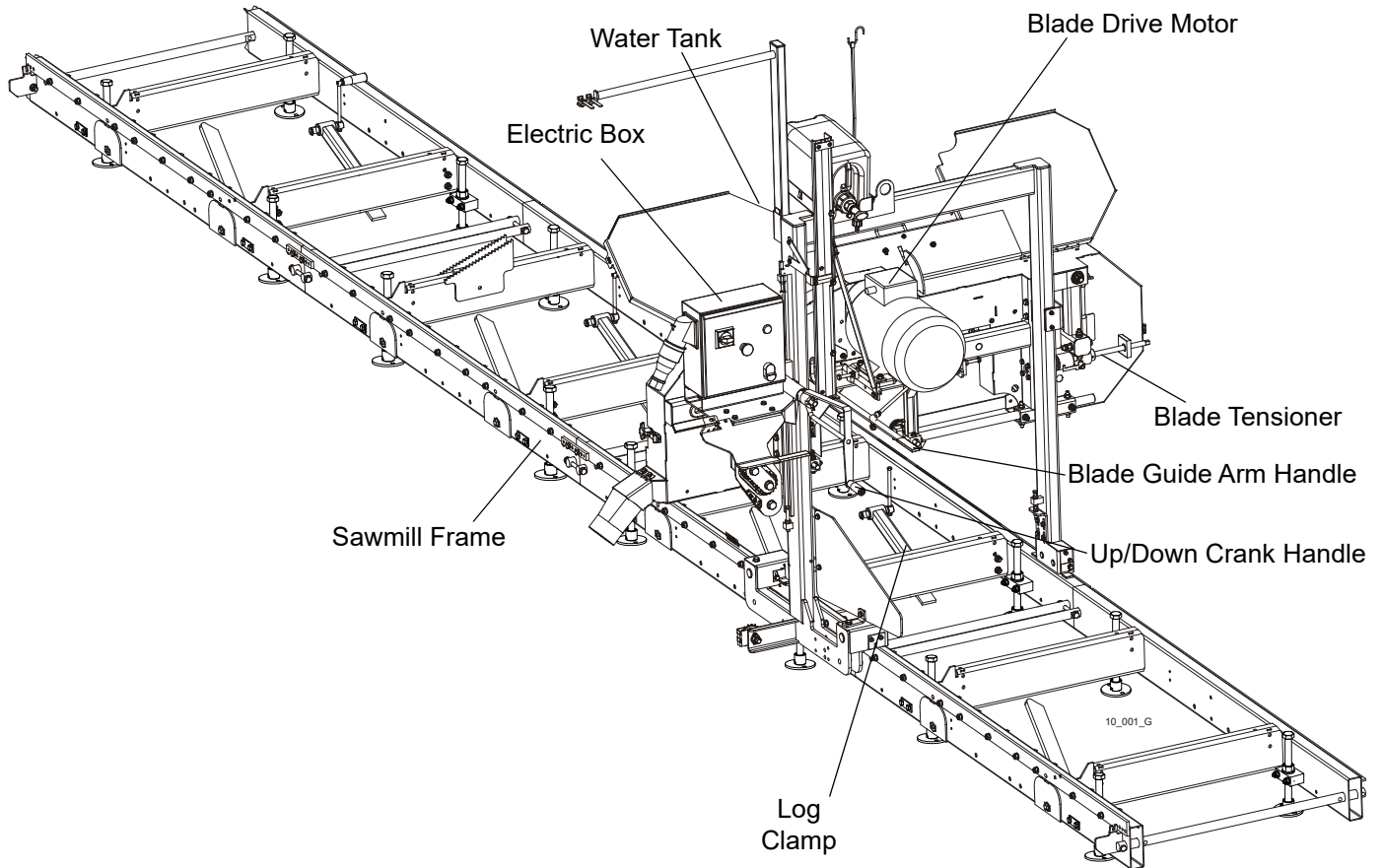

FIG. 1-3

See Figure 1-4. The major components of the Wood-Mizer LT15 are shown below.

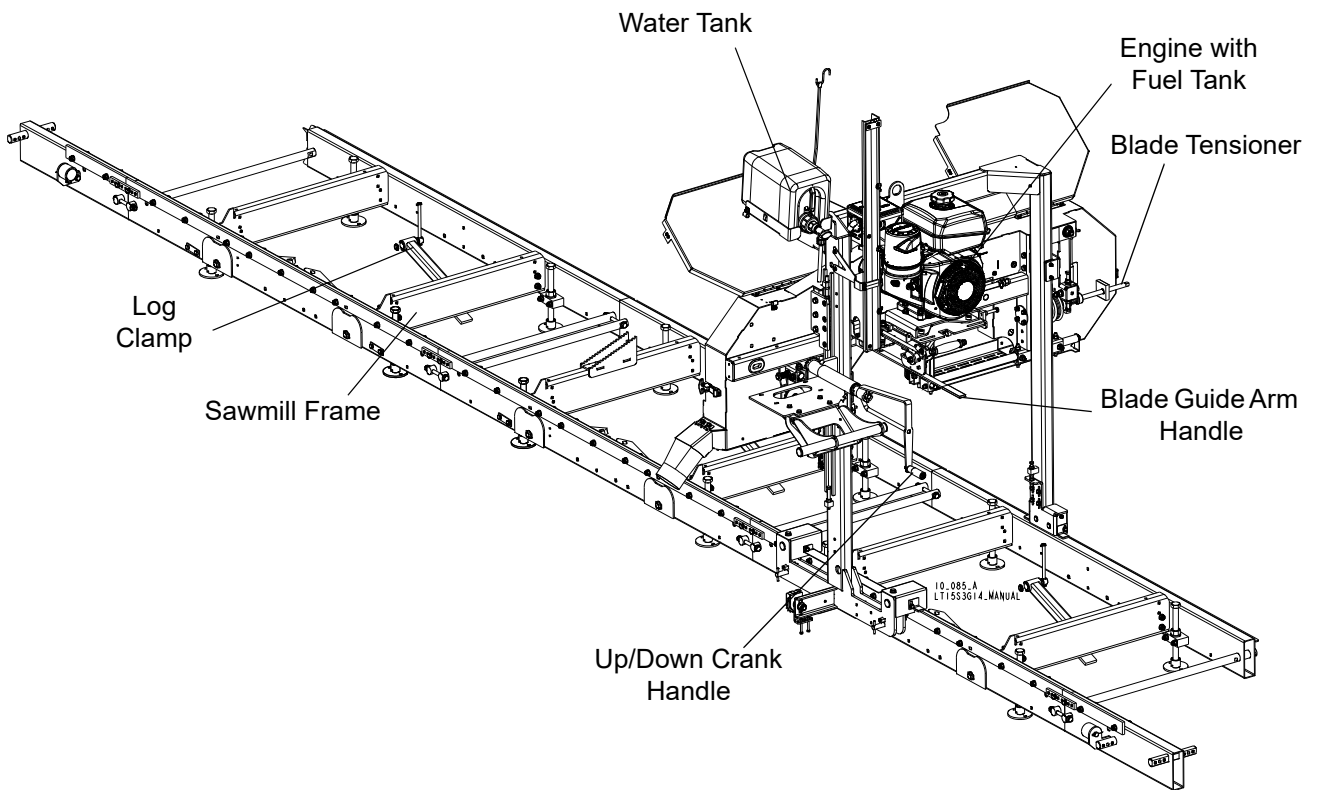

FIG. 1-4

SECTION 2 SAWMILL ASSEMBLY

2.1 Mounting Parts of LT15SA Sawmills with Electric Motors

2.1.1 Parts Specifications

Table 1



Sawmill Mounting Parts					
Fig.	Wood-Mizer No.	Description	Qty.		
			LT15SA S3	LT15SA S4	LT15SA EC
	538800	LT15 Bed Section, Complete (1.95 m)	3	4	3
	085981-1	Thick Spacer Washer	6	8	-
	085982-1	Log Side Support, Complete	6	8	-
	085994-1	Bed Leg Mounting Washer, Painted	12	16	-
	510720-1	Leveling Wedge, Painted	1	1	1
	086132-1	Power Cord Bracket	1	1	1
	086171-1	Side Bracket	2	2	2
	086172-1	Bottom Bracket	1	1	1
	086322	Right Track Wiper	2	2	2
	086323	Left Track Wiper	2	2	2

Table 1





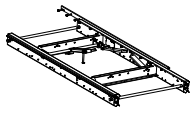
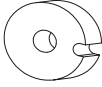
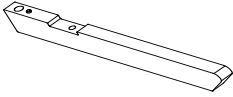
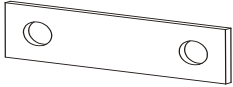
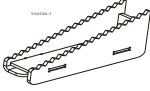
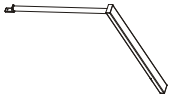
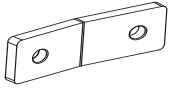
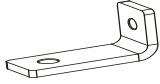

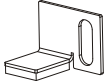



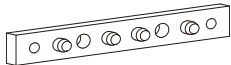
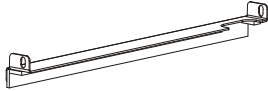

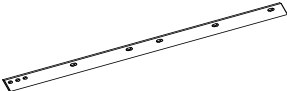
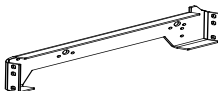
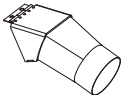
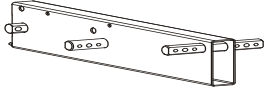



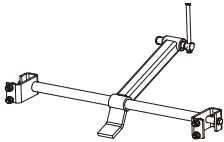

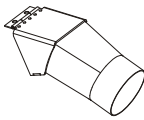

	086659-1	Frame Mounting Strap, Zinc-plated	4	6	3
	086745	Middle Track Cover with Felt Wiper	1	1	1
	093859	Plate, PC Guard	1	1	1
	538811-1	Track Rail, Zinc-plated (Short)	1	1	-
	095490-1	Auxiliary Bed Rail	1	1	-
	100903-1	Sawdust Chute	1	1	-
	538809-1	Bed Extension Tube, Painted	2	2	-
	502725-1	Feed Rope Mount Front Bracket	1	1	-
	502726-1	Feed Rope Mount Rear Bracket	1	1	-
	506287-1	Plate, LT15 Bed Section Connector	12	16	-
	507565	Log Clamp	3	4	3
	508236-1	Feed Rope Mount Front Bracket (LT15-EC)	1	-	1
	508237-1	Feed Rope Mount Rear Bracket (LT15-EC)	1	-	1

Table 1

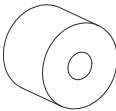
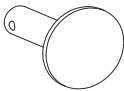
	538799-1 (LT15S3) 094696-1 (LT15M2)	Track Rail	3		
	LTBGAT	Tool, Blade, Guide, Alignment			
	R02080	Rope	9	12	11
	100903-1	Sawdust Chute	1		-
	503768-1	Guide Upright	-		1
	092567-1	Guard, LT15 Upper Saw Head Sprocket	1	1	1
	501414-1	Plate, LT15 Power Feed Support	1	1	1
	P12165	Bushing, 11/16x2 1/8x1 3/4 Rubber	1	1	1
	086182-1	Mount Weldment, Saw Head Stop	1	1	1
	F81043-2	Pin, S-Zn 4x25 PN-M/82001 Cotter	1	1	1
	F81003-2	Bolt, M10x30-8.8 Hex Head Full Thread Zinc	2	2	2
	F81055-2	Washer, Z 10.2 Split Lock Zinc	2	2	2
	F81055-1	Washer, 10,5 Flat Zinc	2	2	2

Outrigger Leg Kit

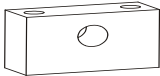
Table 1

	095745-1	Leg Mounting Block	12	18	8
	087771-1	LT15 Foot Mount Plate	12	18	8

2.1.2 Specifications of Fasteners

Table 2:

Wood-Mizer No.	Description	Qty.
Designations of fasteners:		
		
F81000-25	SCREW, M5x16HEX SOCKET HEAD CAP	2
F81001-15	BOLT, M6x16	12
F81001-7	BOLT, M6x12	2
F81002-4	BOLT, M8x20	10
F81002-5	BOLT, M8x25	3
F81003-1	BOLT, M10x20	2
F81003-11	BOLT, M10x25	8
F81003-15	BOLT, M10x75	34
F81003-2	BOLT, M10x30	4
F81003-58	BOLT, M10x120	24
F81003-66	BOLT, M10x90	1
F81004-35	BOLT, M12x140	6
F81004-38	BOLT, M12x120	6
F81004-55	BOLT, M12X130	6
F81007-1	BOLT, M20x240	12
F81030-2	NUT, M5-8	2
F81031-2	NUT, M6-8	12
F81032-2	NUT, M8-8	3
F81033-1	NUT, M10-8 HEX NYLON LOCK	59

Table 2:

F81033-3	NUT, M10-8	6
F81034-1	NUT, M12-8	12
F81034-2	NUT, M12-8 HEX NYLON ZINC LOCK	18
F81037-1	NUT, M20-8	12
F81043-2	PIN, S-Zn 4x25 COTTER	2
F81053-1	WASHER, 6,4	2
F81053-3	WASHER, Z 6,1 SPLIT LOCK	2
F81054-1	WASHER, 8,4 FLAT	16
F81054-4	WASHER, 8,2 SPLIT LOCK	10
F81055-1	WASHER, 10,5 FLAT	100
F81055-2	WASHER, 10.2 SPLIT LOCK	12
F81056-1	WASHER, 13 FLAT	42
F81059-2	WASHER, 21 FLAT	12
Outrigger Leg Kit		
F81003-58	M10x120 Bolt	24
F81007-1	M20x240 Bolt	12
F81037-1	M20 Nut	12
F81059-2	21 Flat Washer	12

2.1.3 Tools Necessary for Assembling the Sawmill**Table 3**

Required tools	
Flat Wrench #8	1pc
Flat Wrench #10	2pcs
Flat Wrench #13	2pcs
Flat Wrench #17	2pcs
Flat Wrench #19	2pcs
Ratchet Wrench #30	1pc
Hammer	1pc
Allen Wrench #4	1pc
Allen Wrench #5	1pc

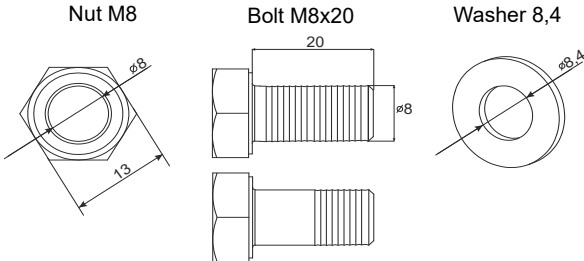
2.2 Unpacking the Sawmill

See Figure 2-1.



FIG. 2-1

1. Cut the bands holding the components together.
2. Remove frame parts from the pallet.
3. Remove up/down crank from the saw head, slide on the up/down handle and secure with the pin (Part No F81045-1).

See Figure 2-2.

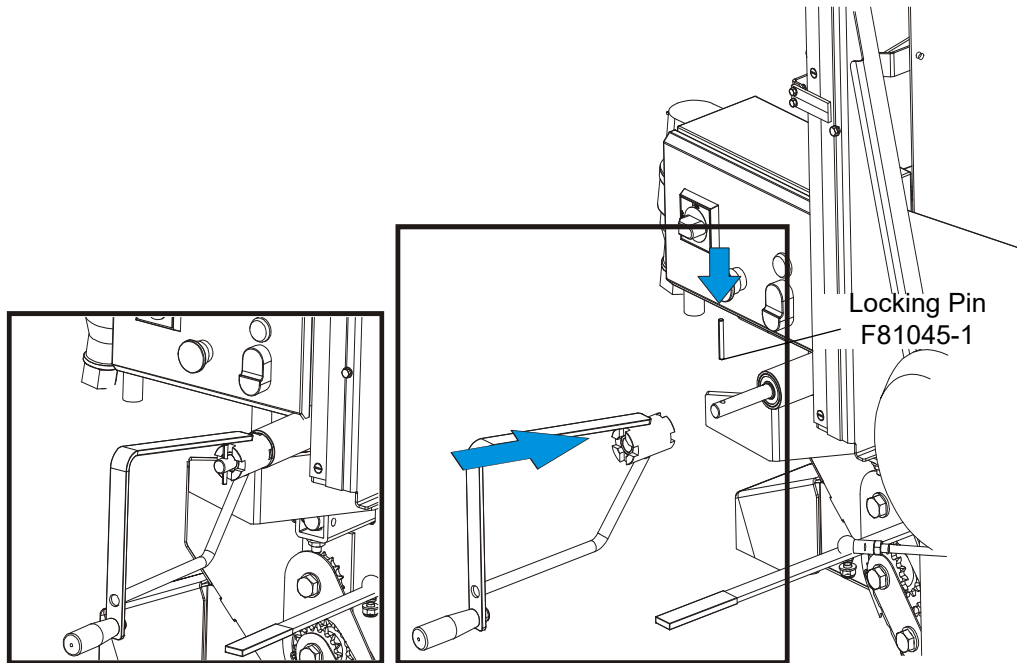

FIG. 2-2

4. Using the up/down crank raise the saw head. Open the box with the sawmill's equipment.

2.3 Bed Frame Assembly



IMPORTANT! With all screw joints without spring lock washer or lock nylon nut, use the "LOCTITE 243" (blue, of average durability, for screw joints).

1. Mount preliminarily the track rail as shown in Figure 2-3. Do not tighten the nuts.

See Figure 2-3.

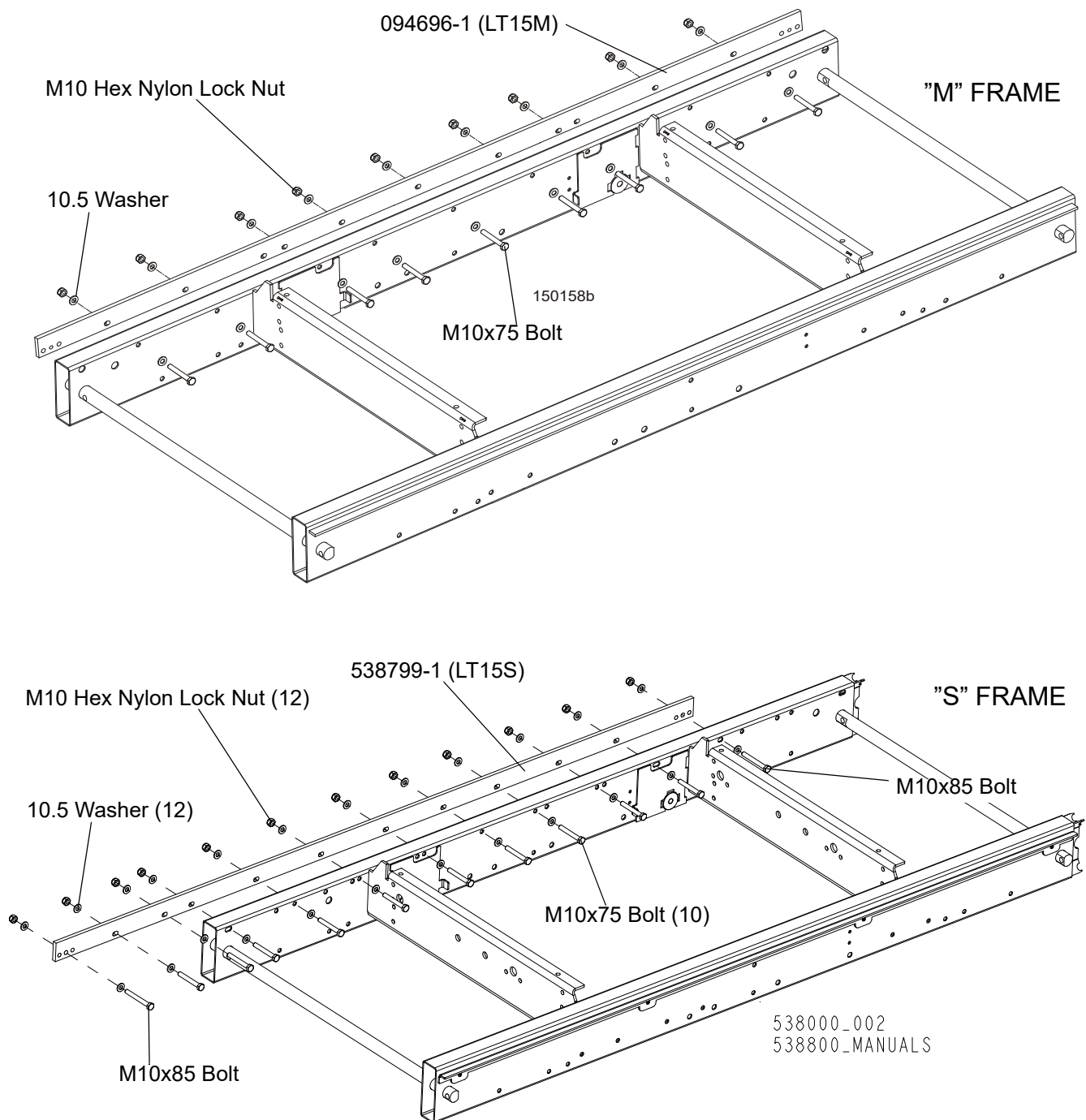

FIG. 2-3

2. **In case of sawmills with adjustable legs** - Mount four (or six) leg brackets to each bed section. Use two hex head bolts and lock nuts to secure each leg bracket to the bed section. Be sure the nut on the bracket faces up. Thread a leg into each bracket.

See Figure 2-4.

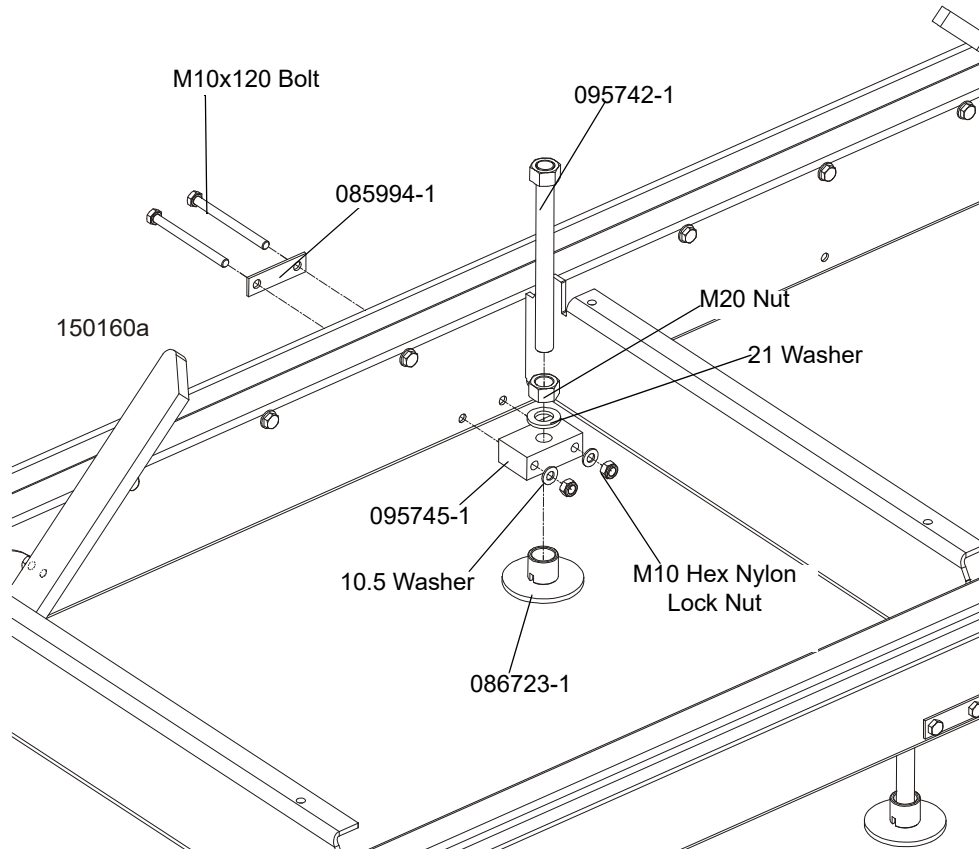

FIG. 2-4

3. **Non-adjustable legs** - Mount four (or six) legs to each bed section. Use two hex head bolts and lock nuts to secure each leg to the bed section.

See Figure 2-5.

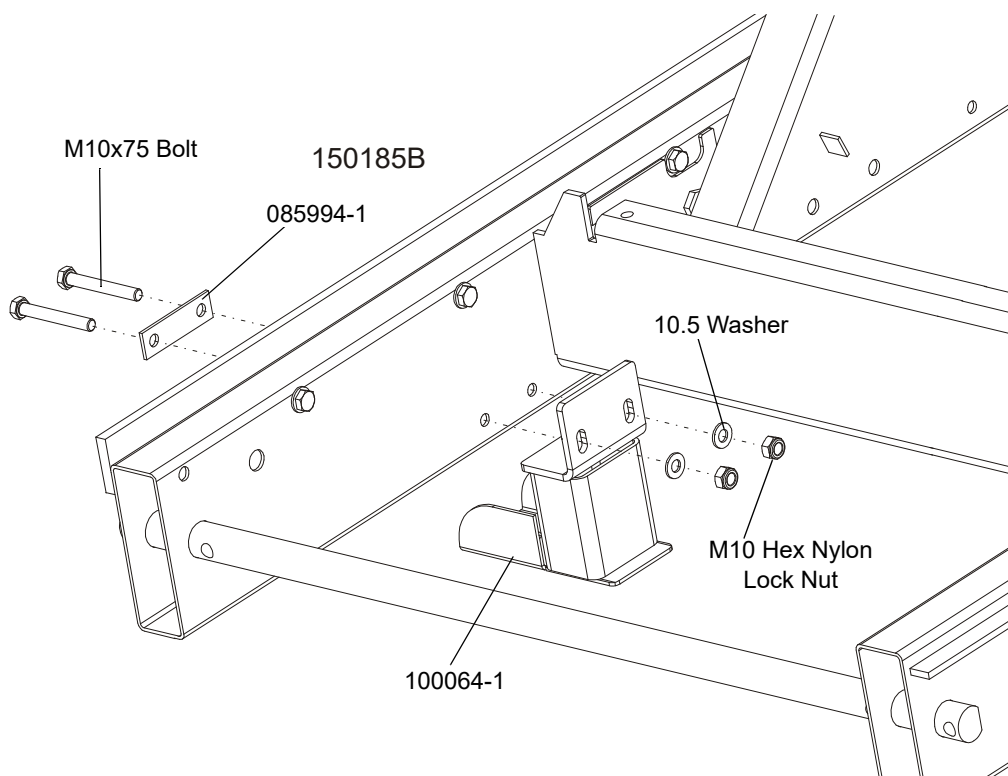

FIG. 2-5

4. Lay the frame sections end-to-end so the track portion of each section is on the same side. Slide the sections together and secure with four hex head bolts and nylon lock nuts.

See Figure 2-6.

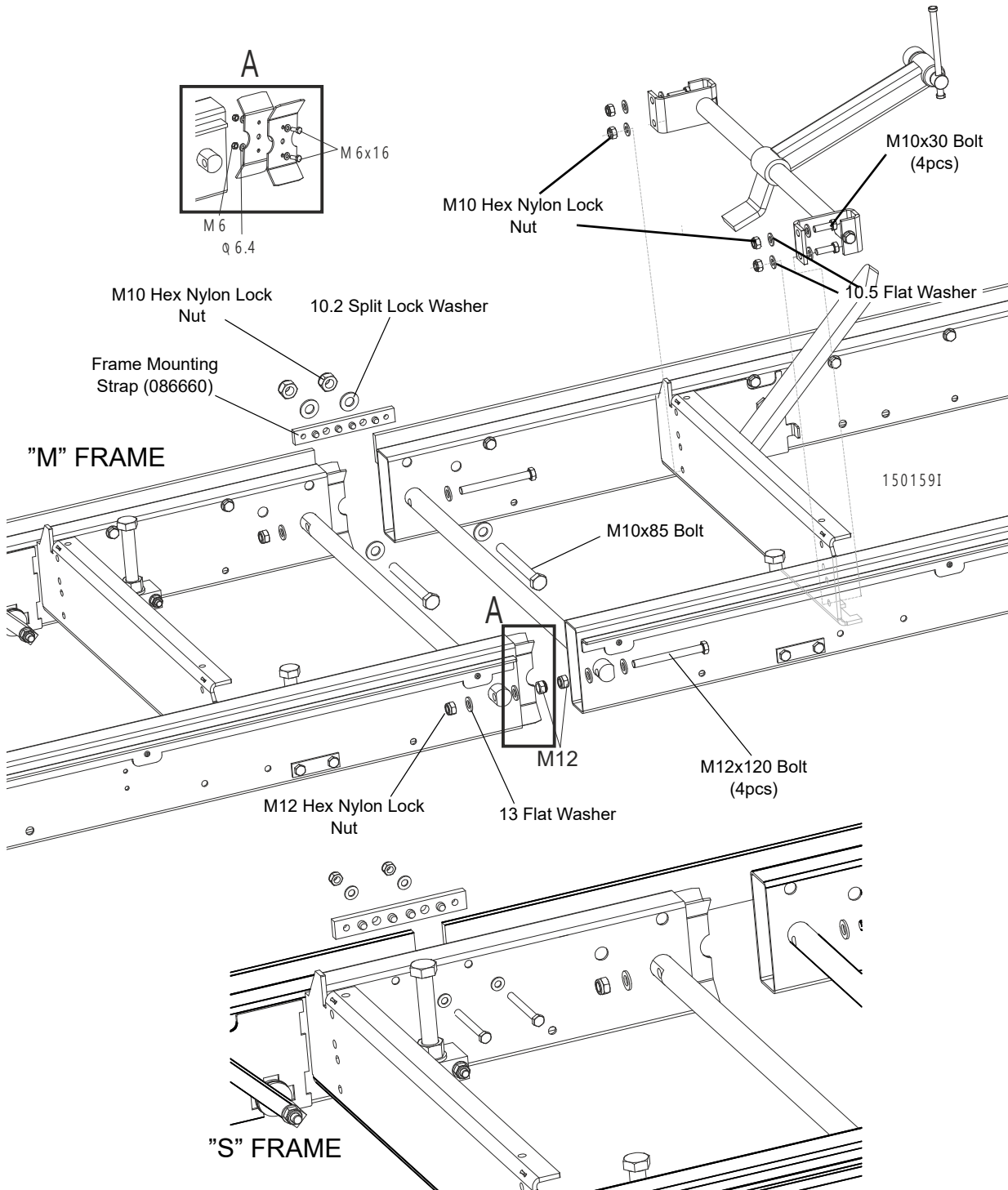

FIG. 2-6

- Fasten the track rails together using the frame mounting straps, on the outside of the frame. (See the figure above.) Secure each strap to the track rail with two hex head bolts. Tighten the track rail mounting nuts.
- Mount a bed extension to the front and the rear ends of the bed frame.

See Figure 2-7.

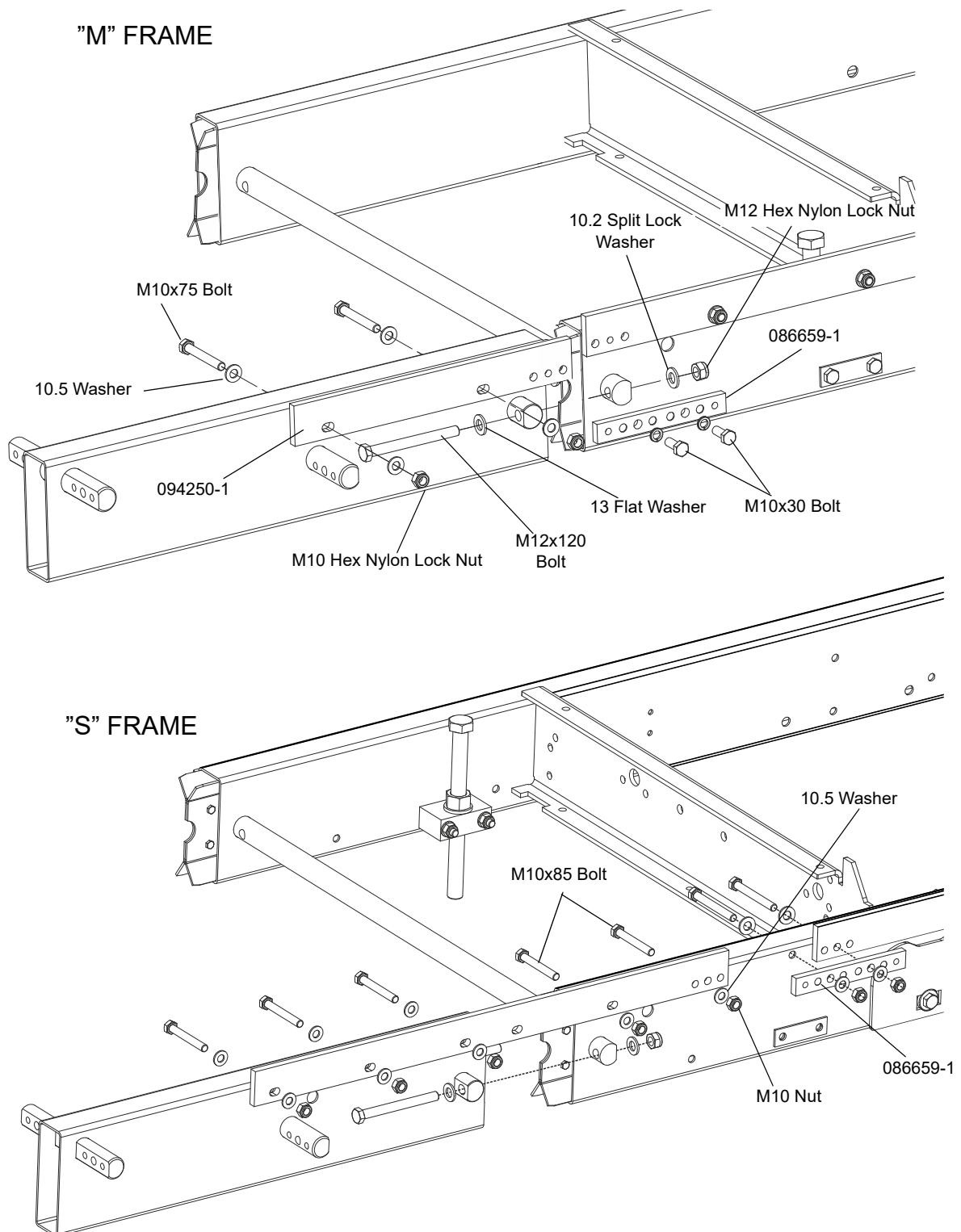

FIG. 2-7

7. Assemble a log clamp to a bed rail on each bed section using the existing hex head bolts and nylon lock nuts.
8. Install the log side supports as shown in Figure 2-8. Tighten the nuts so that the side supports can be moved

with little resistance. Adjust the side supports. [See Section 6.11.](#)

See Figure 2-8.

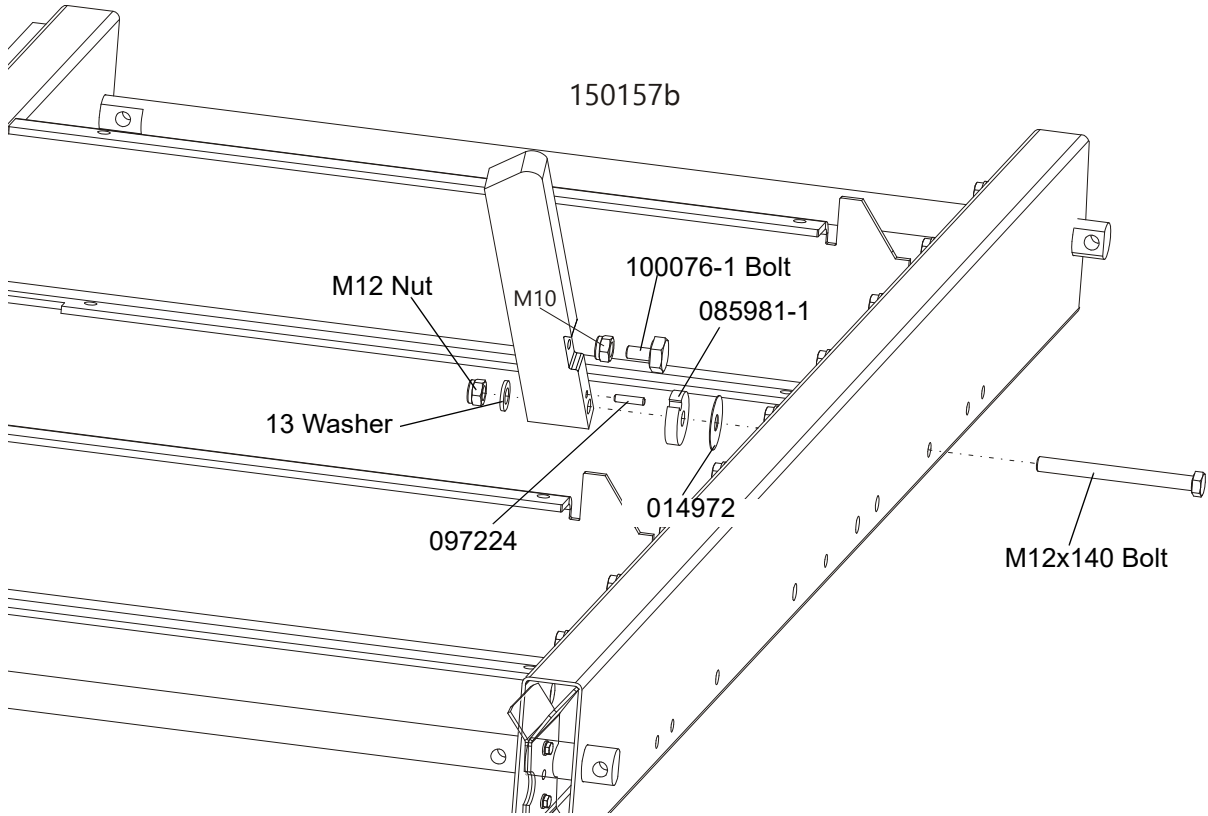

FIG. 2-8

2

SAWMILL ASSEMBLY

Bed Frame Assembly

9. Mount rubber bumpers with brackets to the bed extensions - See figure below.

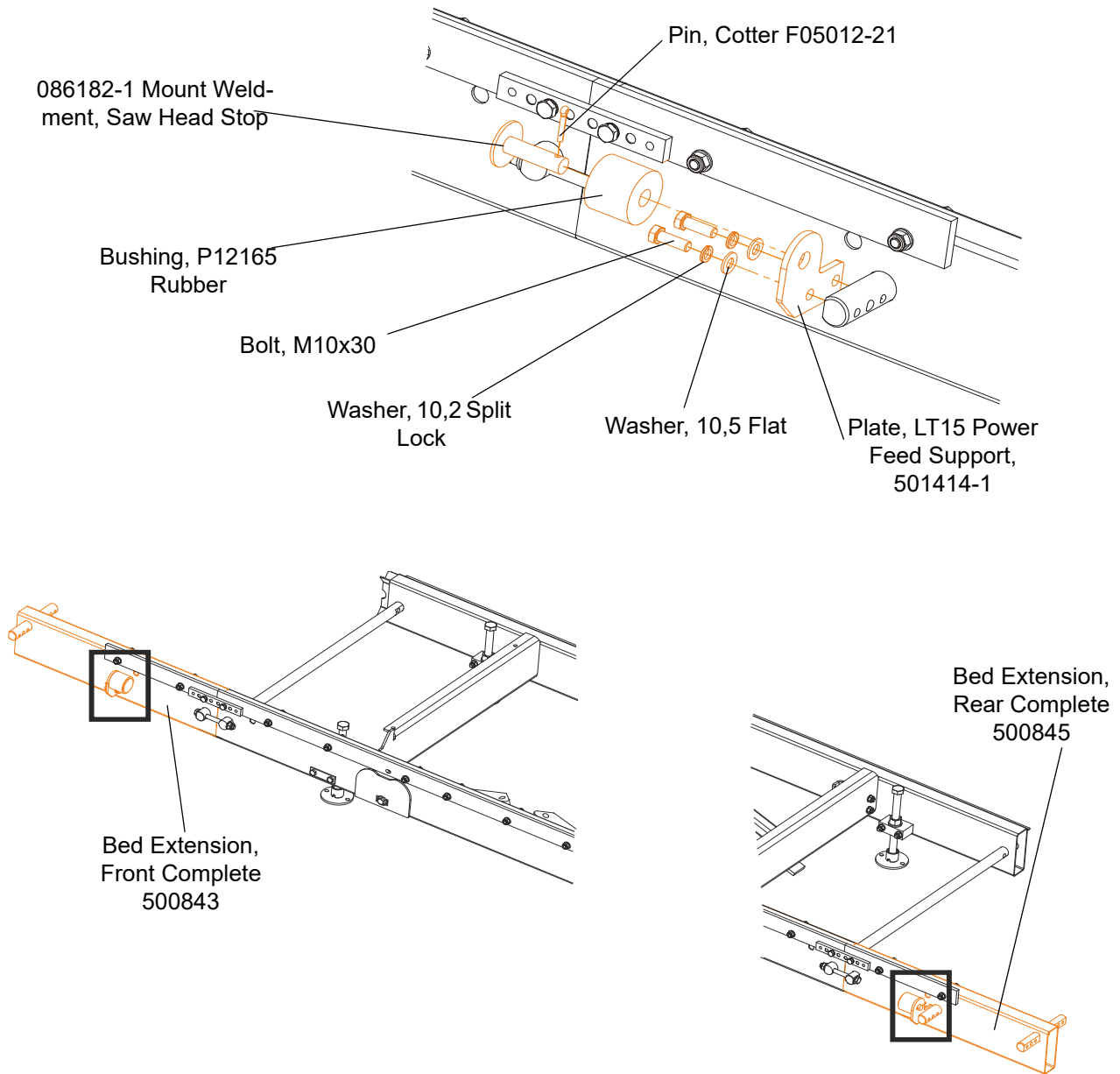

2.4 Frame Leg Adjustment

1. Place a foot plate under each bed leg.
2. Using an appropriate wrench, adjust each leg so that the nut is approximately 25mm below the top of the bed tube

See Figure 2-9.

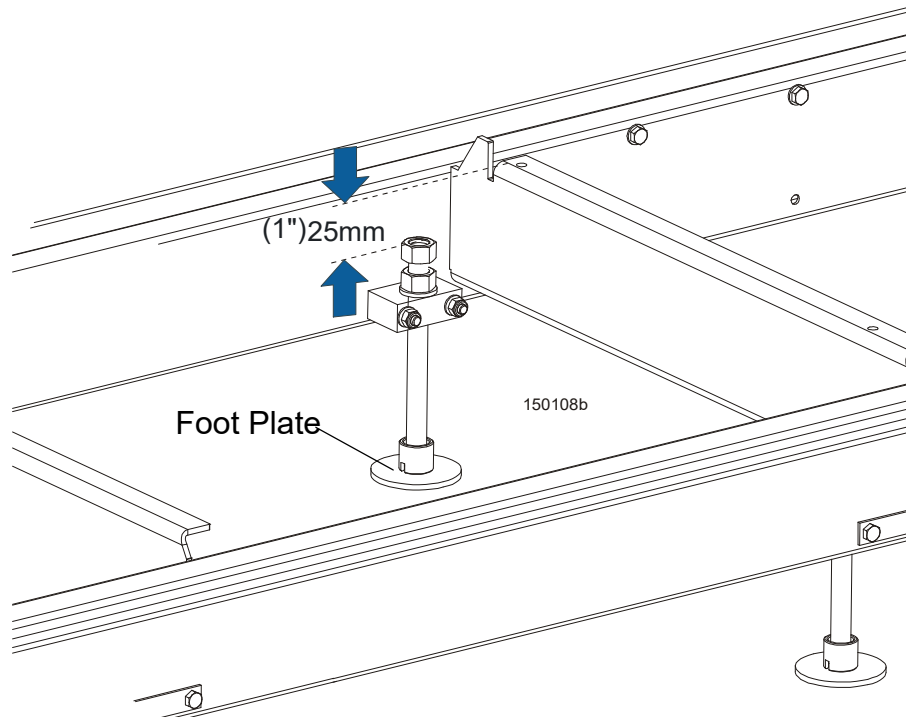



FIG. 2-9

 **CAUTION!** The top of the leg should not be higher than the top surface of the bed rail.

2.5 Saw Head Assembly

1. Using a forklift truck or a winch with lifting capacity of minimum 500 kg, carefully lift the saw head and set it aside. Attach the winch hook to the bracket on the saw head.

 **WARNING!** When removing the saw head, use extreme care and keep all persons at a safe distance. Failure to do so may result in serious injury or death.

See Figure 2-10.

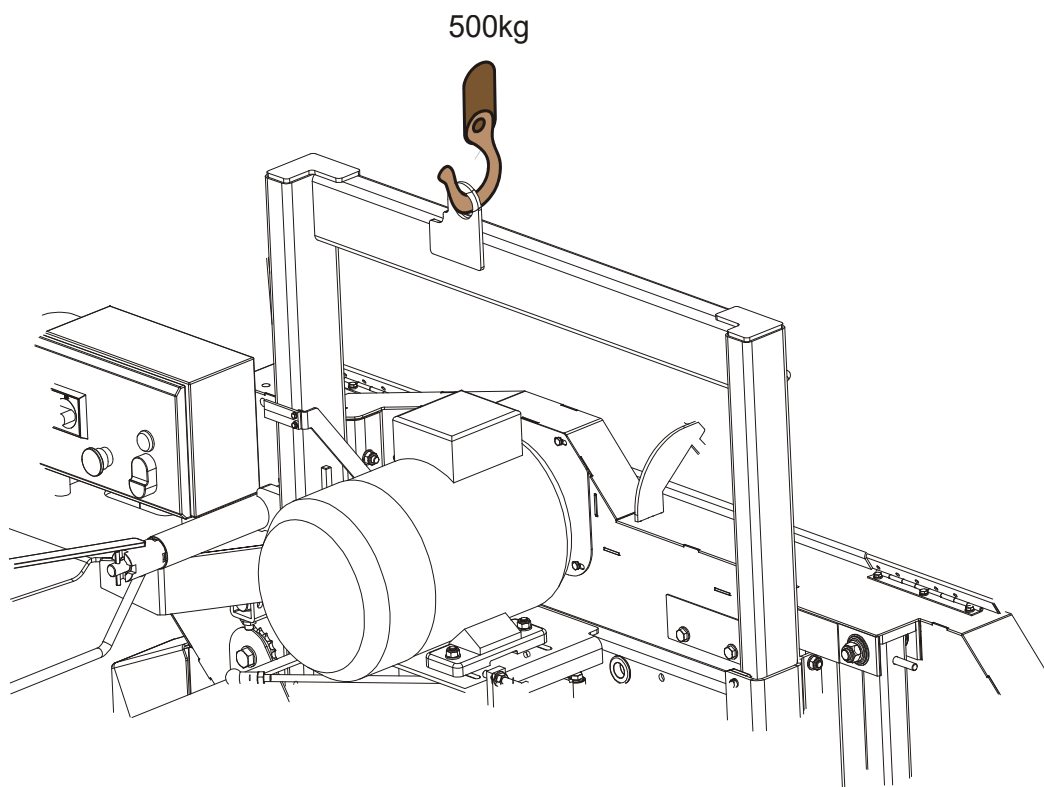
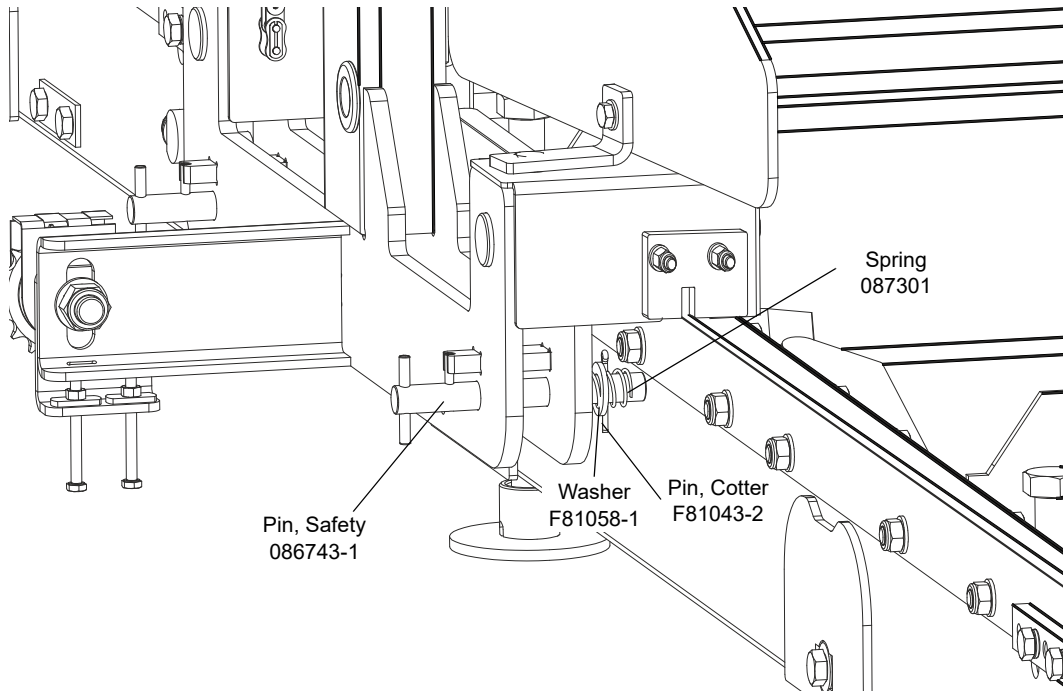

FIG. 2-10

2. Position the saw head at the end of the bed frame assembly. Carefully slide the saw head rollers onto the bed frame track. Keep the saw head square to the bed to avoid jamming the track rollers.

3. Use safety pin to lock the saw head in travel position.



4. Use M6x12 (F81001-7) bolts to install saw head upper sprocket cover to power feed drive shaft housing.

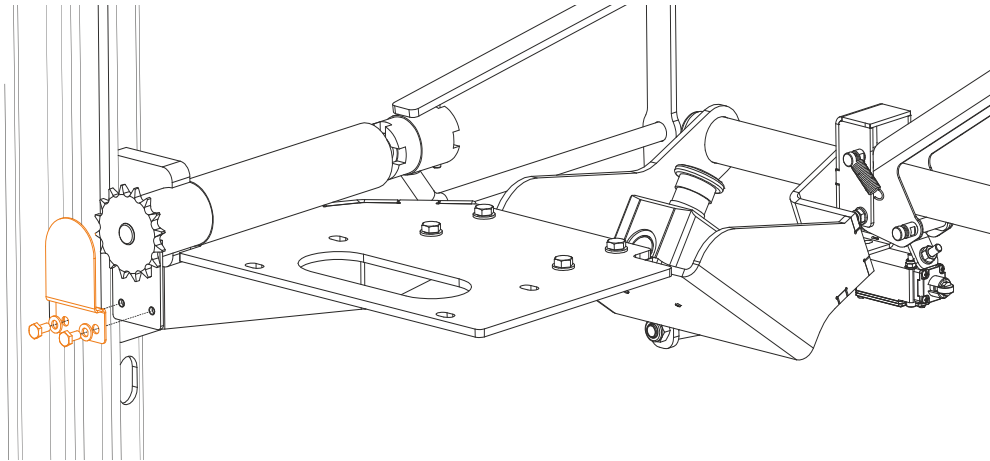

WARNING! When setting the saw head on the bed frame, use extreme care and keep all persons at a safe distance. Failure to do so may result in serious injury or death.

5. Install a track wiper with a felt strip and to each track roller housing as shown below.

See Figure 2-11.

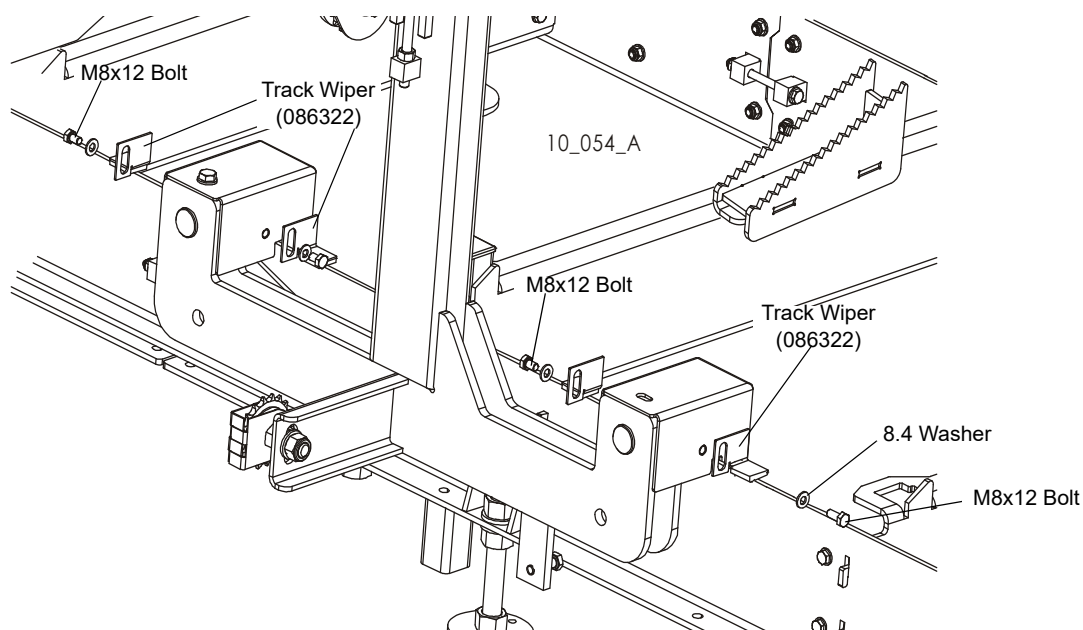

FIG. 2-11

NOTE: Before installing the track cover and the remaining felt wipers, soak the felt strips with lubricating fluid (e.g. mineral oil).

6. Assemble the sawdust chute (100903-1).

See Figure 2-12.

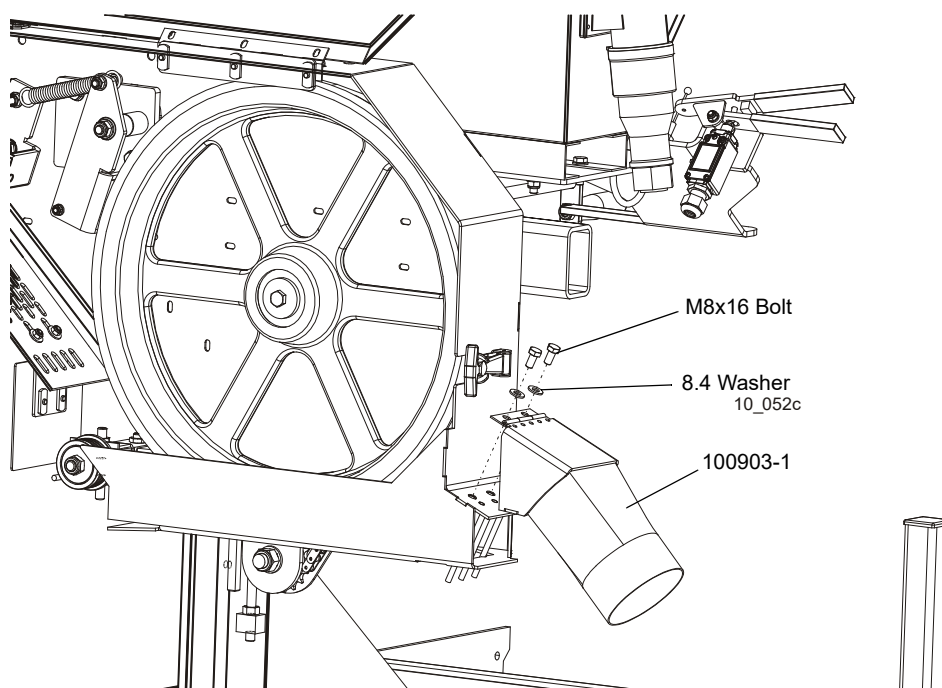

FIG. 2-12

7. Install the operator guard.

See Figure 2-13.

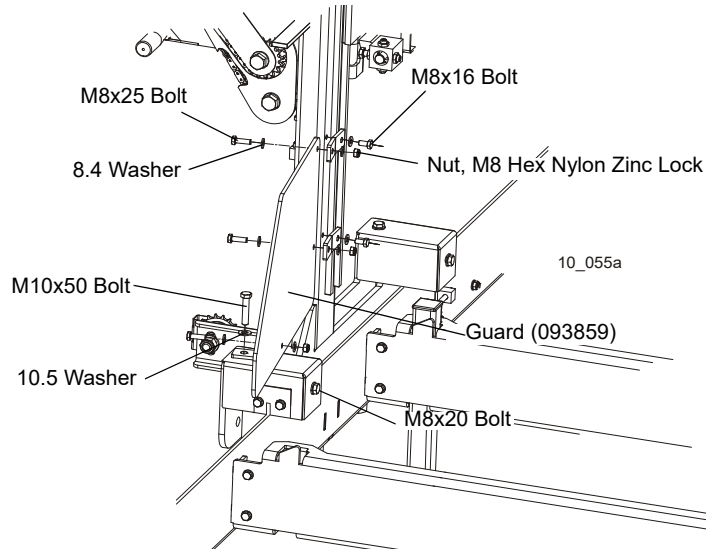

FIG. 2-13

8. Install the blade guides.

See Figure 2-14.

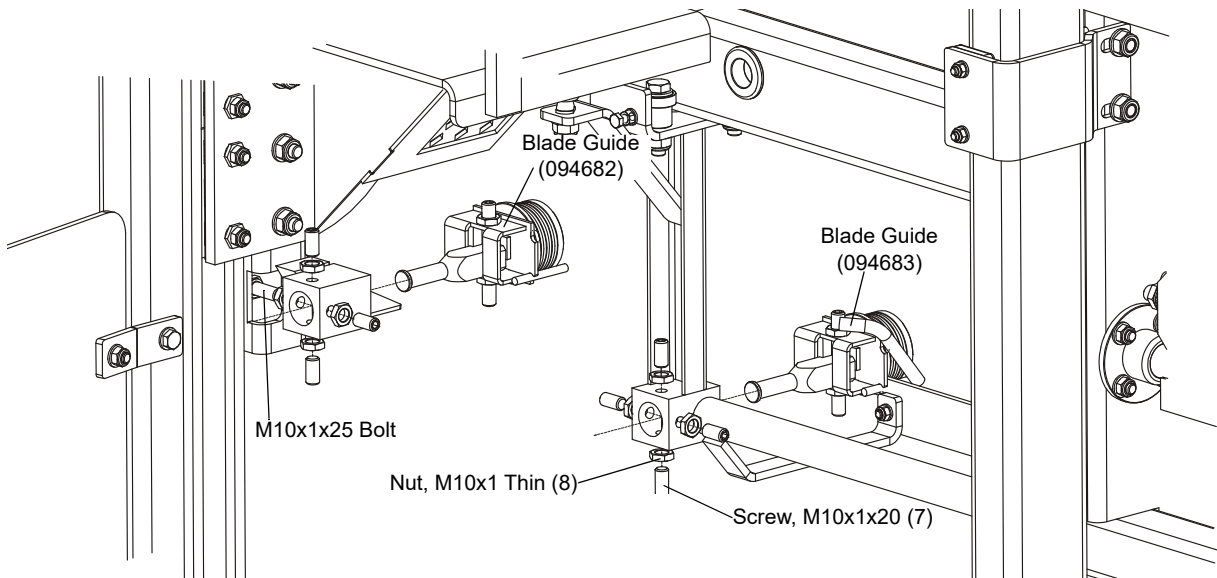

FIG. 2-14

9. Install the power cord bracket.

See Figure 2-15.

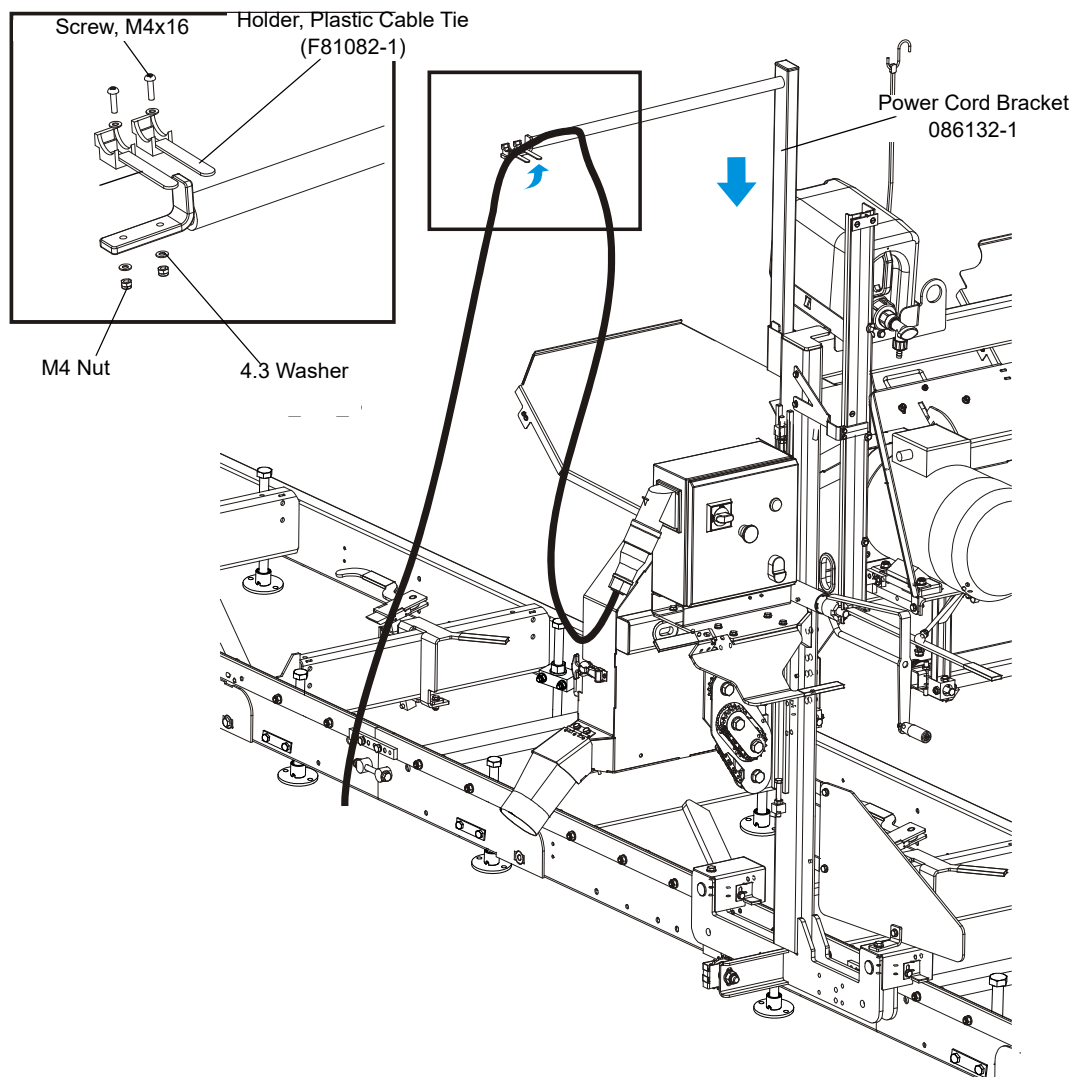

FIG. 2-15

2.6 Log Loading Ramp (Option)

To install the log loading ramp, mount the ramp bracket (1) to the bed frame section tube using two bolts (2), four washers (3) and two nuts (4) in the place shown below. Insert the ramp assembly (5) into the ramp bracket. ¹

1. See the Parts List for detailed information about part numbers and mounting hardware dimensions.

See Figure 2-16.

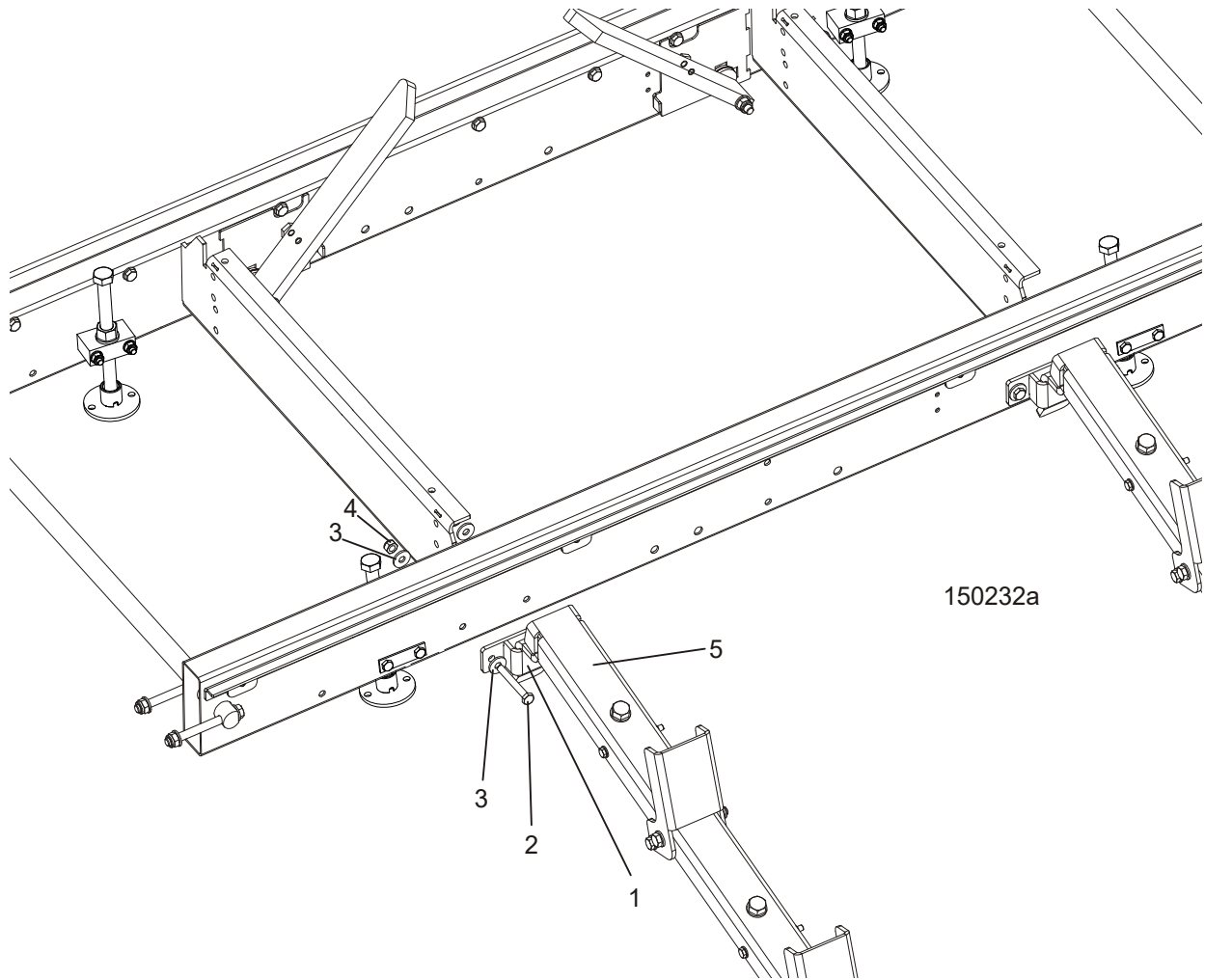

FIG. 2-16

SECTION 3 SETUP & OPERATION

3.1 Sawmill Setup



IMPORTANT! Before starting to use the sawmill you have to meet the following conditions:

3.1.1 Sawmills with electric blade drive motor

- Set up the sawmill on firm, level ground and level the sawmill. Secure the sawmill to the ground to prevent moving during operation. A concrete foundation or pads (rated to support 31 T/m² at each sawmill foot position) and 16mm anchored bolts are recommended.
- Under roof, the sawmill should always be operated with the sawdust collection system.
- The sawmill cannot be operated outdoors when it is raining/snowing and in case of rain/snow the sawmill must be stored under roof or indoors.
- The sawmill can be operated in temperature range of -15° C to 40° C only.
- The illumination at the operator's position should be at least 300lx.
- The sawmill operator's position is shown below.

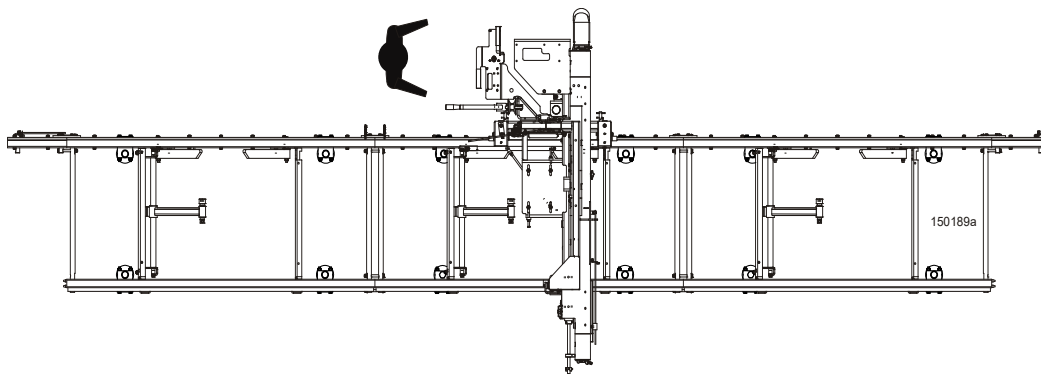



- Have a qualified electrician install the power supply (according to EN 60204 Standard). The power supply must meet the specifications given in the table below.

See Table 3-1.

3-Phase Volts	Fuse Disconnect Switch	Suggested Wire Size
400 VAC	16 A	2,5 mm ² to 15m length

TABLE 3-1

 **IMPORTANT!** When starting the machine for the first time, check that main motor rotation direction is as indicated by the arrow located on the motor body (fan guard). If the rotation direction is incorrect, invert the phases in the phase inverter in the power socket (electric box). Setting the phases in the phase inverter correctly will ensure correct rotation directions of all sawmill motors.

 **WARNING!** If the blade or drive belt breaks, wait until all rotating parts are completely stopped. Failure to do so may result in serious injury.

 **DANGER!** It is recommended that a 30mA Ground Fault Interrupter (GFI) be used.

3.1.2 *Sawmills with gas blade drive engine:*

- Set up the sawmill on firm, level ground and level the sawmill. Secure the sawmill to the ground to prevent moving during operation. A concrete foundation or pads (rated to support 31 T/m² at each sawmill foot position) and 16mm anchored bolts are recommended.
- It is not allowed to use the sawmill with gas engine indoor. When using this sawmill type outdoor it is allowed to work without sawdust collection system connected. We recommend to setup sawmill in the way that operator position be down the wind. It will separate the operator from sawdust and engine exhaust gases
- The sawmill can be operated in temperature range from -15° C to 40° C only.
- The illumination at the operator's position should be at least 300lx.
- The sawmill operator's position is shown below.

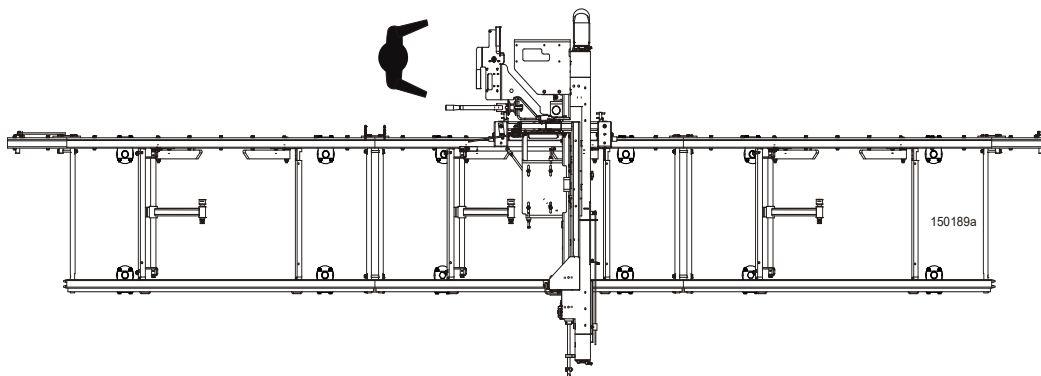

Sawmills are only partially aligned at the factory. Some assemblies need to be aligned by the user before first usage of the sawmill.

Assemblies aligned at the factory:

- Blade drive belt tension,
- Blade wheels (in vertical and horizontal planes)
- Blade guide arm alignment - [See Section 6.5](#),
- Blade guides - [See Section 6.6](#),
- Blade Height Scale - [See Section 6.12](#).

The following setup procedure should be performed whenever the sawmill is moved or reassembled. If sawing problems occur and misalignment is suspected, see [See 6.1](#) for complete alignment instructions.

1. Adjust the frame legs so the sawmill appears level. If sawmill is on soft ground, use shims under the legs if necessary.
2. Run a string from the front bed rail to the rear bed rail near the operator's side of the frame. Place identical spacers between the string and the front and rear bed rails. Measure the distance between the string and the other bed rails. Adjust the frame legs until all bed rails measure the same distance from the string.
3. Loosen the auxiliary bed rail bolts and adjust the rail so it is the same distance from the string as the main bed rails. Retighten the bolts.

See Figure 3-1.

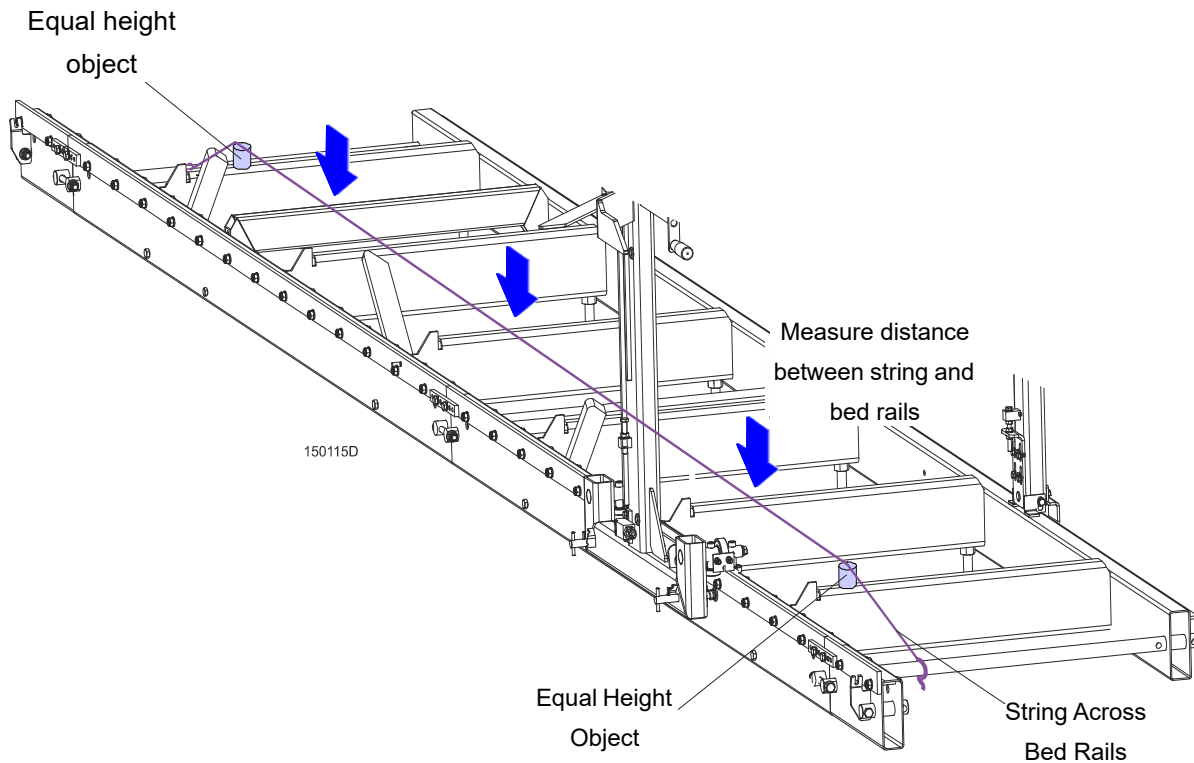

FIG. 3-1

4. Repeat the bed rail adjustment with the string at the other side of the sawmill frame.
5. Install a blade ([See Section 3.2](#) through [Section 3.4](#)) and move the saw carriage until the blade is positioned over the front bed rail.
6. The blade guide rollers should not touch and deflect the blade and the blade guide arm should be adjusted all the way out, away from the other blade guide.
7. Measure the distance from the bed rail to the bottom of the blade near the inside (fixed) blade guide.
8. Measure the distance from the bed rail to the bottom of the blade near the outside (movable) blade guide.

See Figure 3-2. When the blade is parallel to the bed, it will measure the same distance from the bed rail at the inside and outside of the saw head. To adjust the saw head tilt, loosen the four mounting bolts of the idle side roller bracket, the two scraper mounting bolts and the two mounting bolts of the mast retaining bracket. Use the saw head adjustment nuts to move the outside of the

3 Setup & Operation

Sawmills with gas blade drive engine:

saw head up or down.

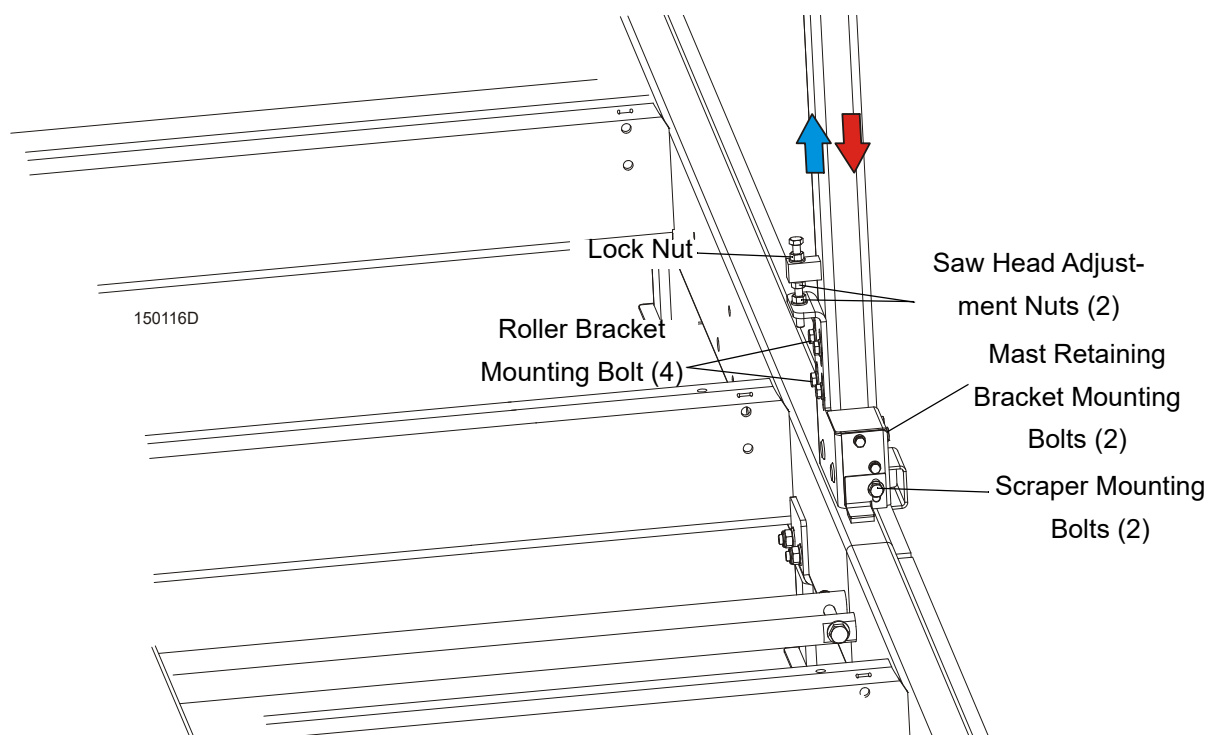

FIG. 3-2

9. Make sure the entire face of each slide pad makes contact with the mast. Use the adjustment nuts shown below to adjust the slide pads if necessary.

See Figure 3-3.

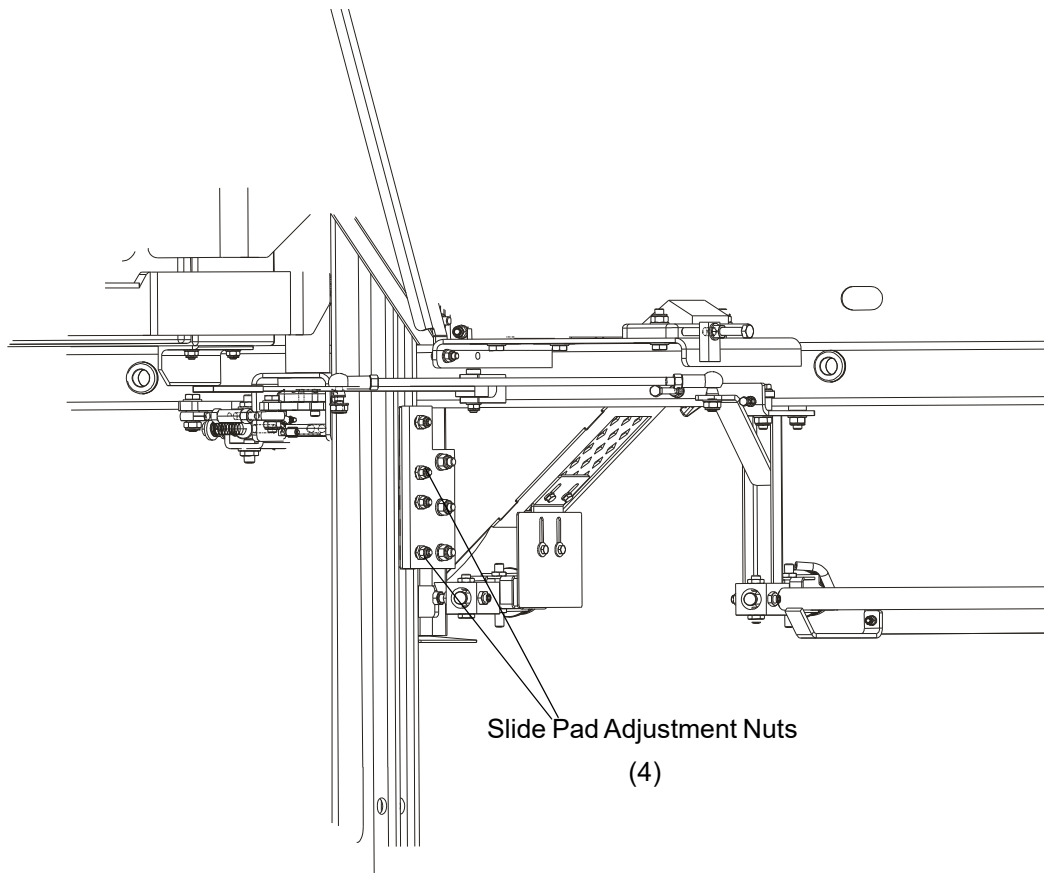

FIG. 3-3

10. Check the vertical alignment of each blade wheel using the blade guide alignment tool.

- Attach the tool to the blade near the outer blade guide. Be sure the tool does not rest on a tooth or burr, and is lying flat on the blade.

See Figure 3-4.

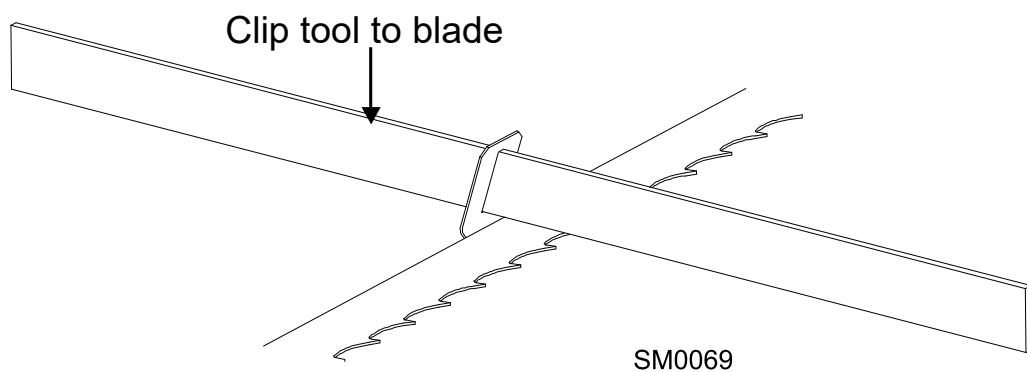

FIG. 3-4

3

Setup & Operation

Sawmills with gas blade drive engine:

- Move the saw head so the front end of the tool is positioned over the first bed rail. Measure from the bottom of the tool to the top surface of the bed rail.
- Move the saw head so the rear of the tool is positioned over the bed rail. Again, measure from the bottom of the tool to the bed rail.
- If the two measurements differ by more than 1/16" (1.5 mm), adjust the vertical tilt of the idle-side blade wheel. [See Figure 3-5.](#)
- Remove the tool from the blade and reattach it near the inner blade guide. Measure from the tool to the bed rail at both ends of the tool. If the measurements at the front and rear ends of the tool differ by more than 1/16" (1.5 mm), adjust the vertical tilt of the drive-side blade wheel. [See Figure 3-6.](#)

See Figure 3-5. To tilt the idle-side blade wheel up, loosen the bottom adjustment screw 1/2 turn. Loosen the nut on the top adjustment screw and tighten the screw. Tighten the top and bottom nuts.

To tilt the wheel down, loosen the top adjustment screw 1/2 turn. Loosen the nut on the bottom adjustment screw and tighten the screw. Tighten the top and bottom nuts.

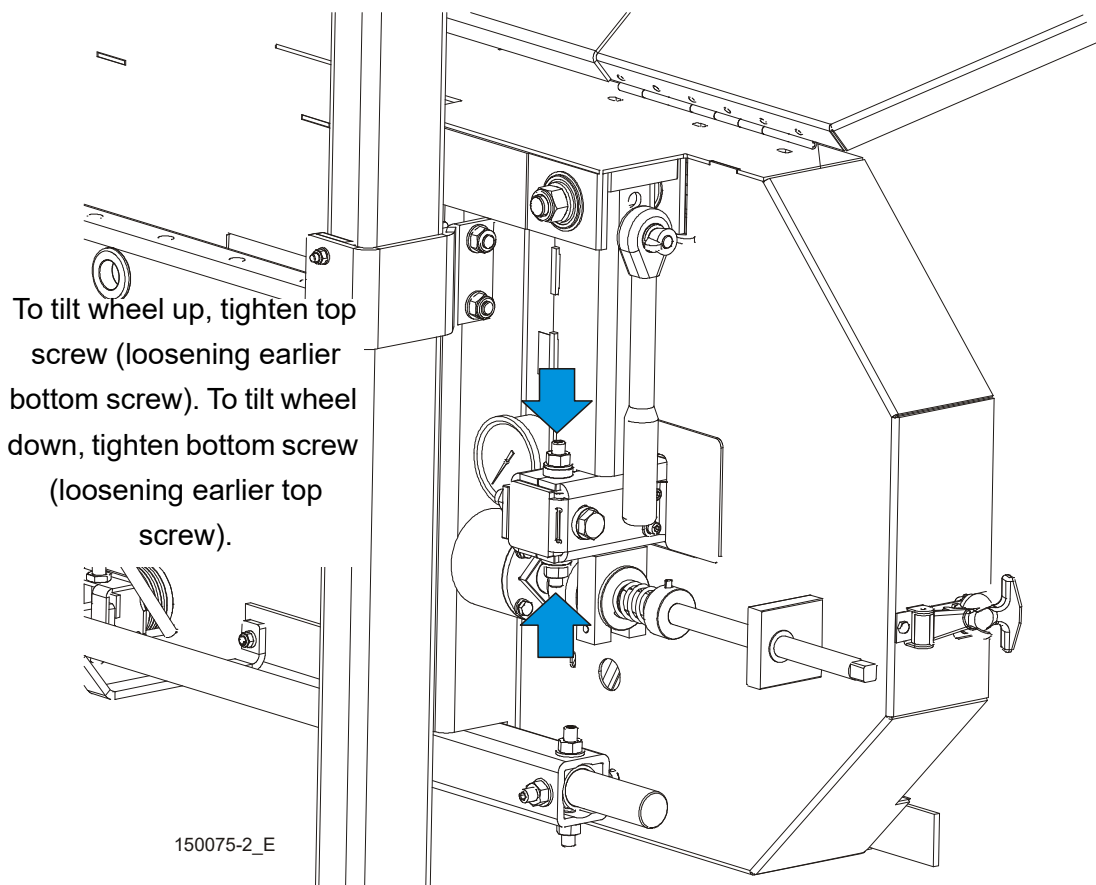

FIG. 3-5

See Figure 3-6. To tilt the drive-side blade wheel down, loosen the top adjustment screw, loosen the nut on the bottom adjustment screw and tighten the bottom screw. Tighten the top and bottom nuts.

To tilt the wheel up, loosen the bottom adjustment screw, loosen the nut on the top adjustment screw and tighten the top screw. Tighten the top and bottom nuts.

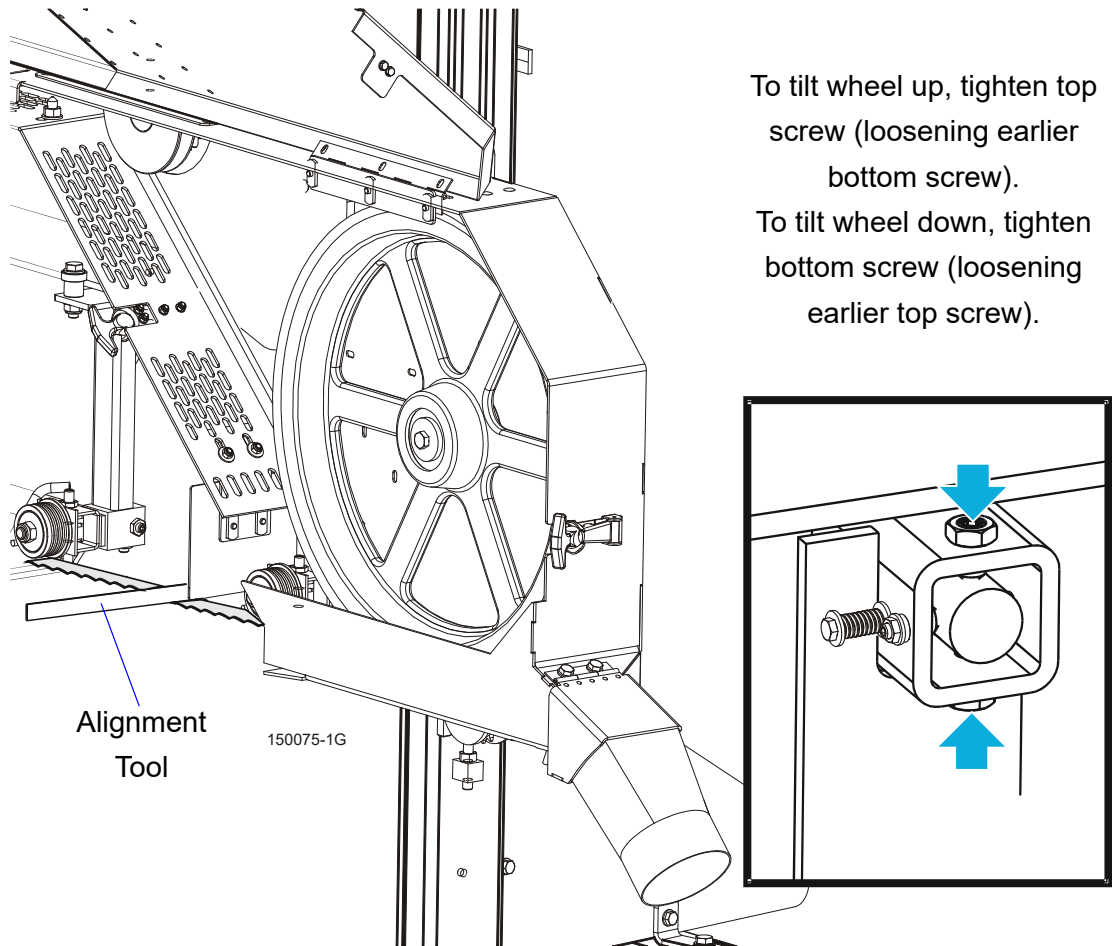

FIG. 3-6

- Re-check the vertical alignment of each blade wheel. Readjust if necessary.

11. Adjust the spacing between each blade guide roller flange and the back of the blade. [See Section 6.9.](#)
12. Adjust the horizontal angle of the blade guides. [See Section 6.10.](#)
13. Adjust the blade deflection ([See Section 6.7](#)) and the vertical angle of the blade guides ([See Section 6.8](#)).

HINT: It is best to preliminarily set the blade deflection so that it is 3 - 4 mm, then adjust the blade guides in the vertical plane and make the final adjustments to the blade deflection. The proper blade deflection is 6 mm. After adjusting the blade deflection, recheck the vertical alignment of the blade

guides and adjust if necessary.

14. Install the blade height scale. To do that, first measure the distance from the bottom edge on a down-set tooth of the blade to the top of the bed rail. Then stick the blade height scale on the mounting bracket so that it indicates the true distance from the blade to the bed. Adjust the scale if necessary. [See Section 6.13.](#)
15. Bolt the blade guide guard so that its bottom edge is about 5 mm above the blade.

See Figure 3-7.

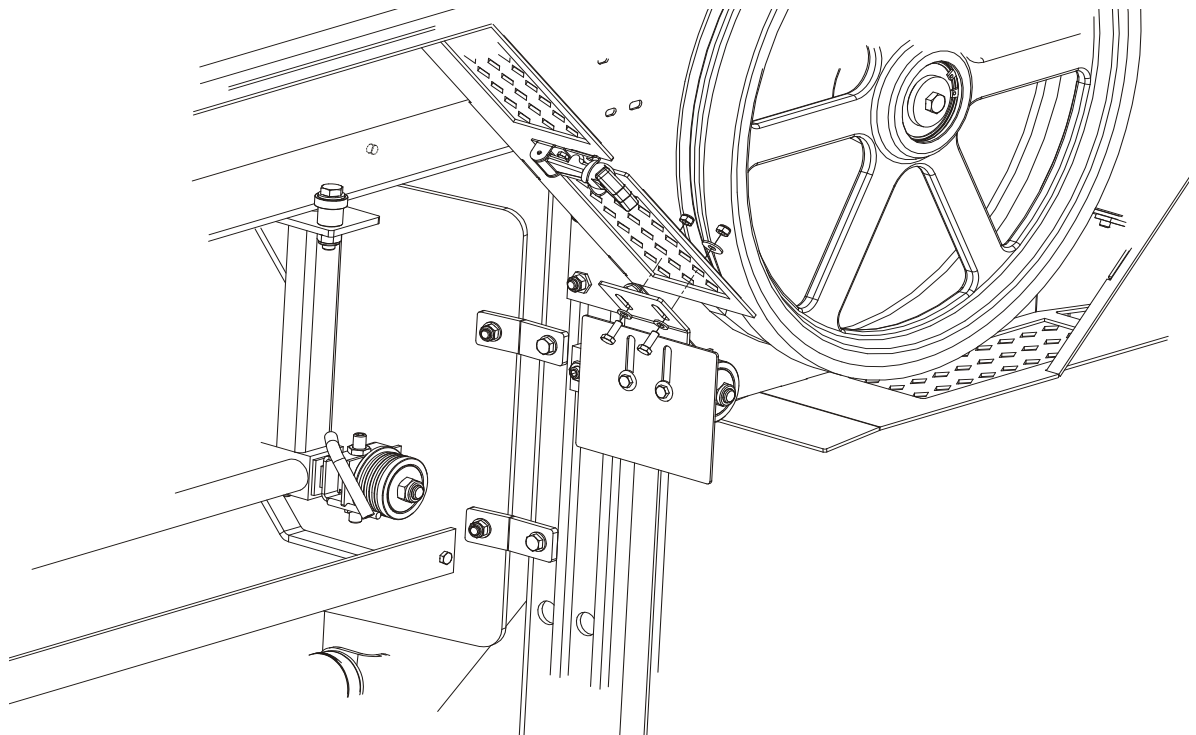

FIG. 3-7

16. Adjust the cam engaging the limit switch as well as the saw head stop bolt so that the saw head stops moving at its lower travel limit, i.e. at the height of 25 mm above the bed.

See Figure 3-8.

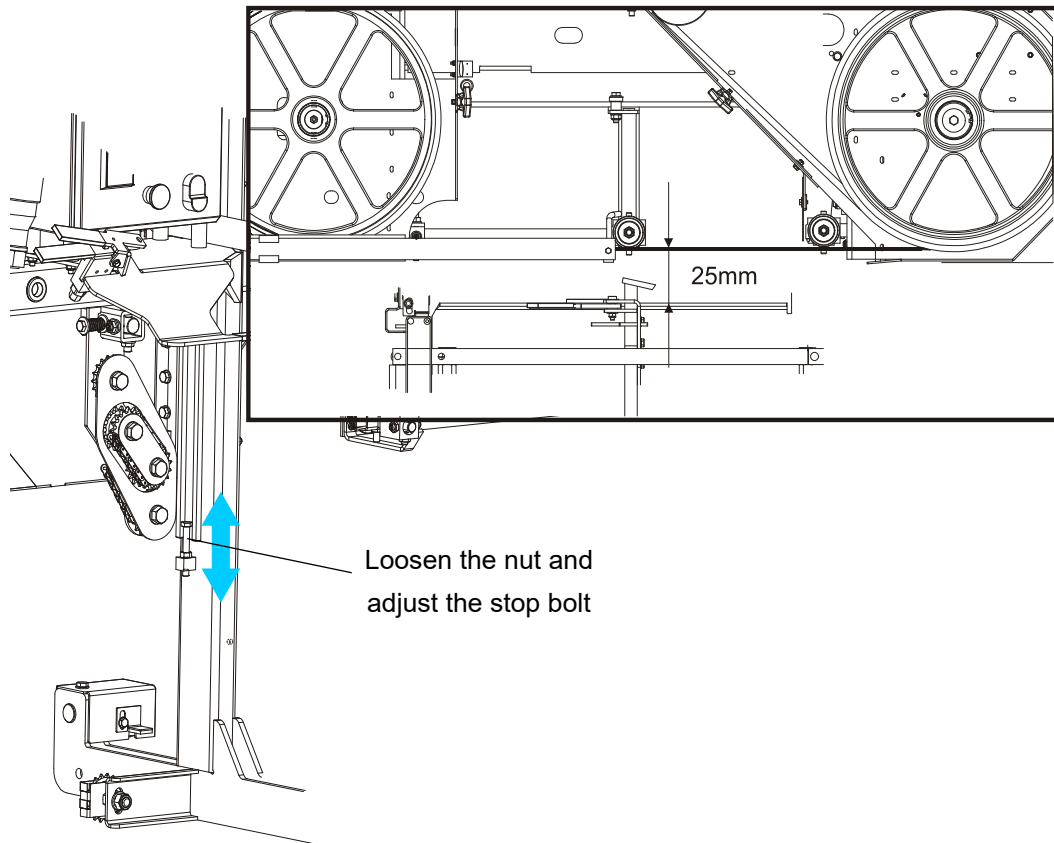





FIG. 3-8

17. Adjust the side bracket. [See Section 6.13.](#)

 **WARNING!** Adjust the side bracket before first operating the sawmill. Failure to do so may result in serious injury and machine damage.

3.2 Replacing The Blade

 **DANGER!** Always disengage the blade and shut off the sawmill motor before changing the blade. Disconnect the power supply using the main switch. Failure to do so will result in serious injury.

 **WARNING!** Always wear gloves and eye protection when handling bandsaw blades. Changing blades is safest when done by one person! Keep all other persons away from area when coiling, uncoiling, carrying or changing a blade. Failure to do so may result in serious injury.

Adjust the blade guide arm all the way open.

Open the blade housing cover. Turn the blade tension handle to release the blade tension until the wheel is pulled in and the blade is lying loose in the blade housing. Lift the blade out of the blade housing.

Install a new blade on the blade wheels. When installing the blade, make sure the teeth are pointing the correct direction. The teeth located between the blade guide assemblies should be pointing toward the sawdust chute.

Position 1 1/4" wide blades on the wheels so the gullet is 1/8" (3.0 mm) out from the front edge of the wheel. Position 1 1/2" wide blades on the wheels so the gullet is 3/16" (4.5 mm) out from the front edge of the wheel.

Close the blade housing cover.

Next, turn the tension handle until the blade is tensioned correctly.

3.3 Tensioning The Blade

See Figure 3-9. Turn the blade tension handle clockwise until the tension gauge indicates the recommended tension. Check the blade tension occasionally when adjusting the cant control or while cutting. As the blade and belts heat up and stretch, the blade tension will change. Also, ambient temperature changes can cause tension to change.

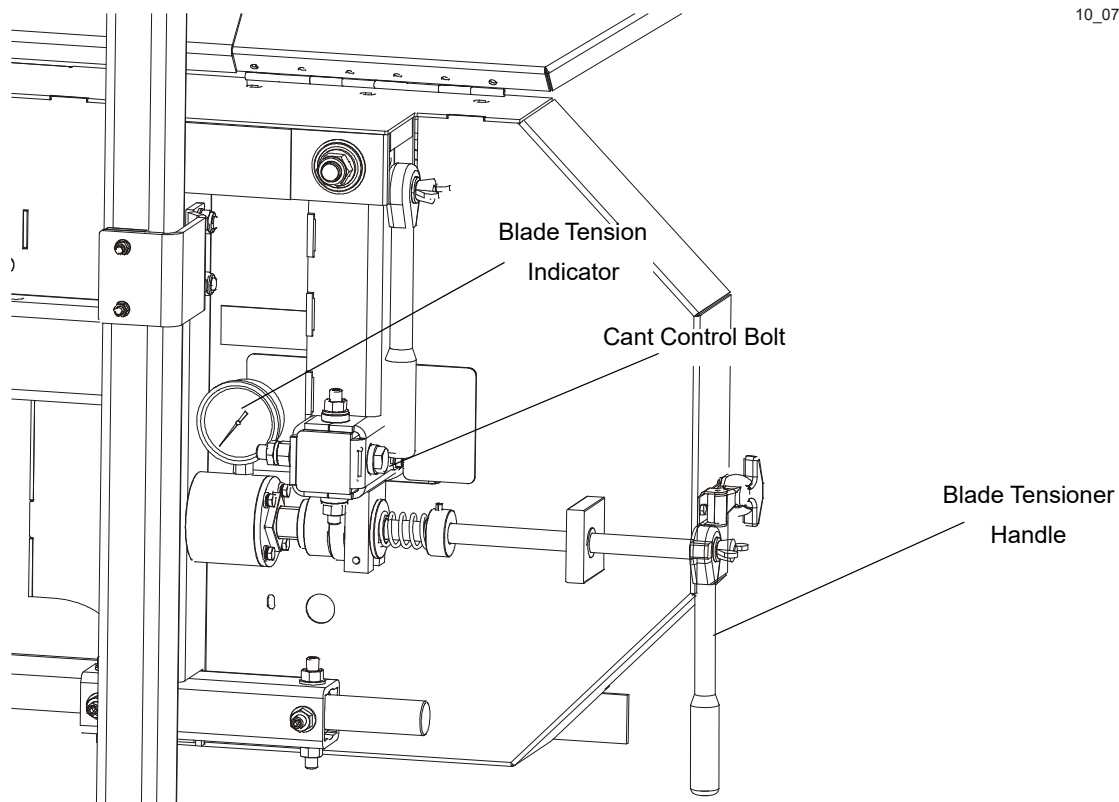

FIG. 3-9

See Table 3-2. The recommended tension for different blades is shown below.

Blade Type	Blade Dimensions		Tension Range	
	Width (mm)	Height (mm)	PSI	Bar
275	1.07	32	1015-1088	70-75
375	1.14	32	1088-1160	75-80
2735	1.07	35	1160-1233	80-85

TABLE 3-2



CAUTION! Release the blade tension when the sawmill is not in use (for example at the end of a shift). Tension the blade again before starting the motor.

3.4 Tracking The Blade

Electric Sawmill:

1. Make sure the blade housing cover is closed and all persons are clear of the blade.
2. Start the motor for a moment until the blade positions itself on the wheels.



WARNING! Do not spin the blade wheels by hand. Spinning the blade wheels by hand may result in serious injury.

3. Turn off the engine and check the position of the blade on the blade wheels.

See Figure 3-10. Position 1 1/4" wide blades so the gullet is 1/8" (3.0 mm) out from the edge of the

blade wheel ($\pm 1/32$ [.75 mm]).

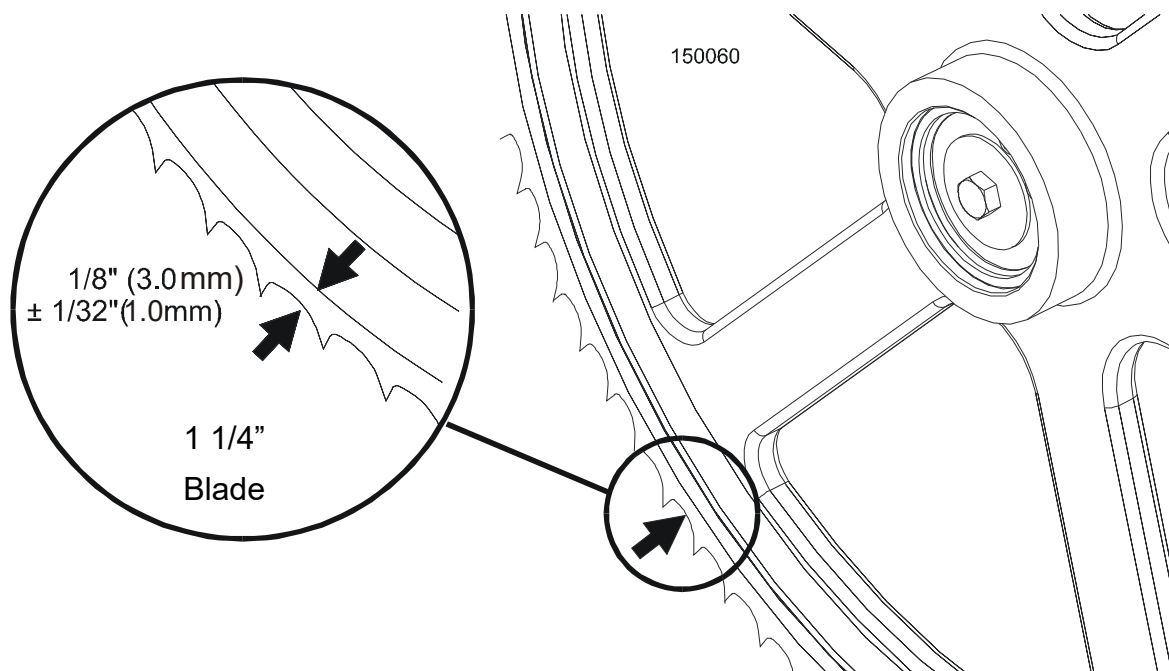

FIG. 3-10

See Figure 3-11. To adjust where the blade travels on the blade wheels, use the cant control bolt.

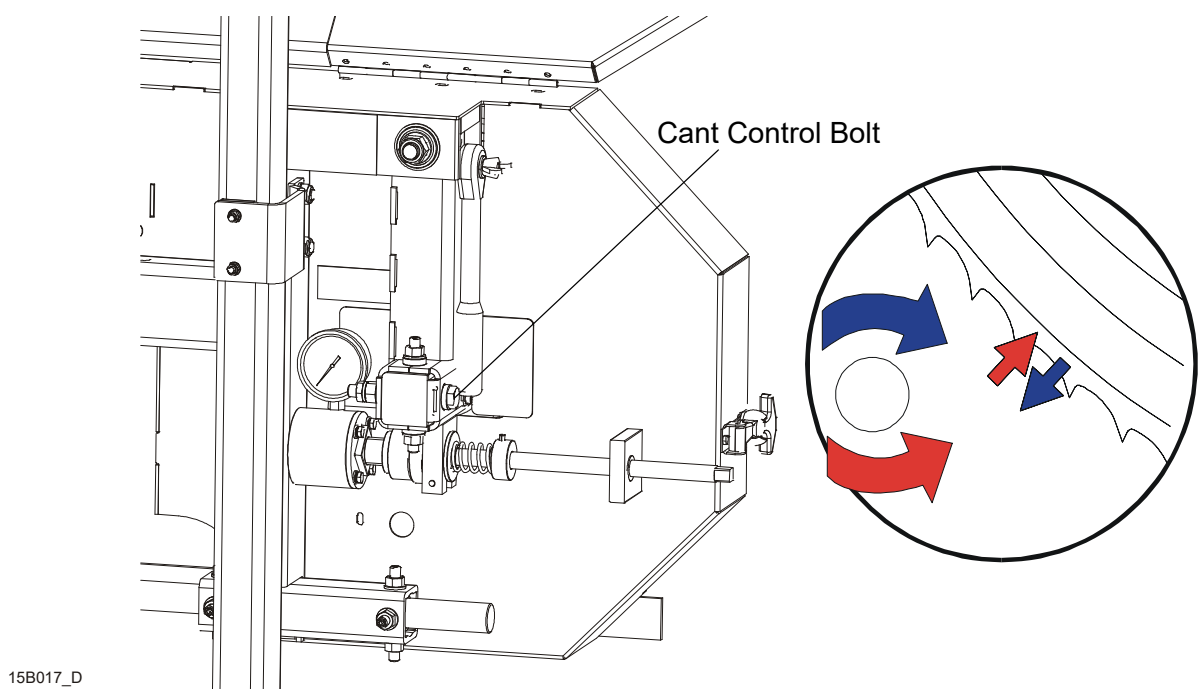

FIG. 3-11

If the blade is too far out, back the blade onto the wheel by turning the cant control counterclockwise. If the blade is too far in, turn the cant control clockwise until the gullet of the blade is the correct

distance from the front edge of the wheel.

4. Adjust the blade tension if necessary to compensate for any changes that may have occurred while adjusting the cant control.
5. Close the blade housing cover.

DC Sawmill:

1. Before tracking the blade, make sure the engine is off and the key is removed from the ignition.
2. Move the tensioner lever to the intermediate position (in this position, the brake is unlocked and the drive is disengaged) and lock with the pin.
3. Open the blade housing cover.
4. Manually spin one of the blade wheels until the blade positions itself on the blade wheels.
5. Check if the blade is properly positioned on the blade wheels.

See Figure 3-12. Position 1 1/4" wide blades so the gullet is 1/8" (3.0 mm) out from the edge of the blade wheel ($\pm 1/32$ [.75 mm]).

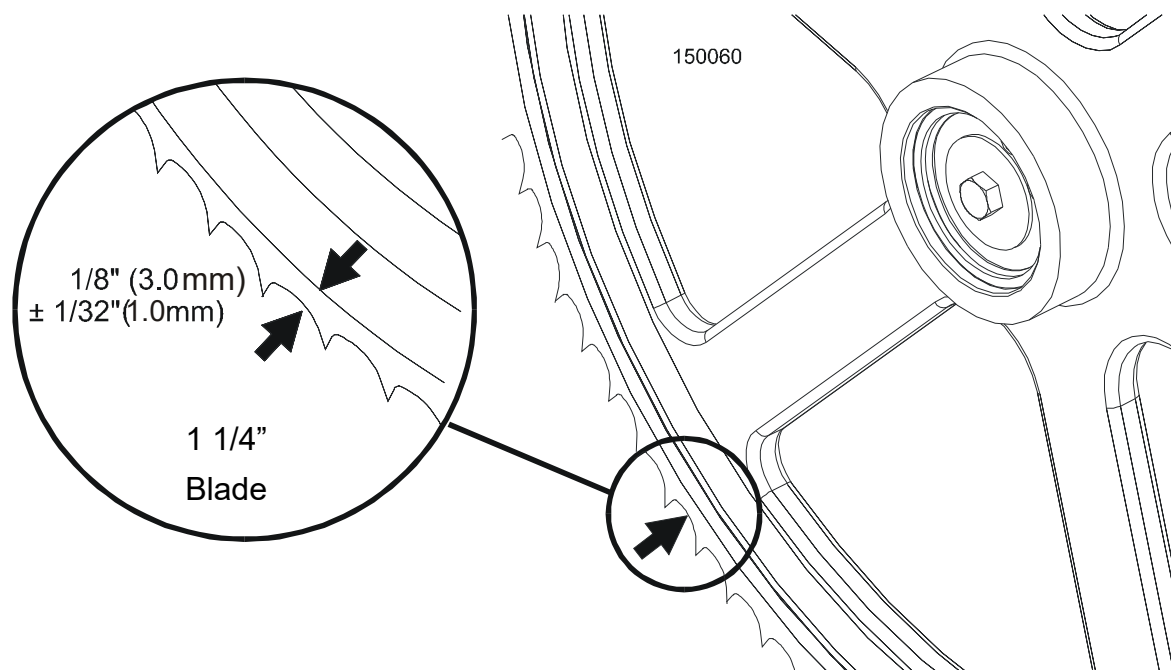

FIG. 3-12

See **Figure 3-13**. To adjust where the blade travels on the blade wheels, use the cant control bolt.

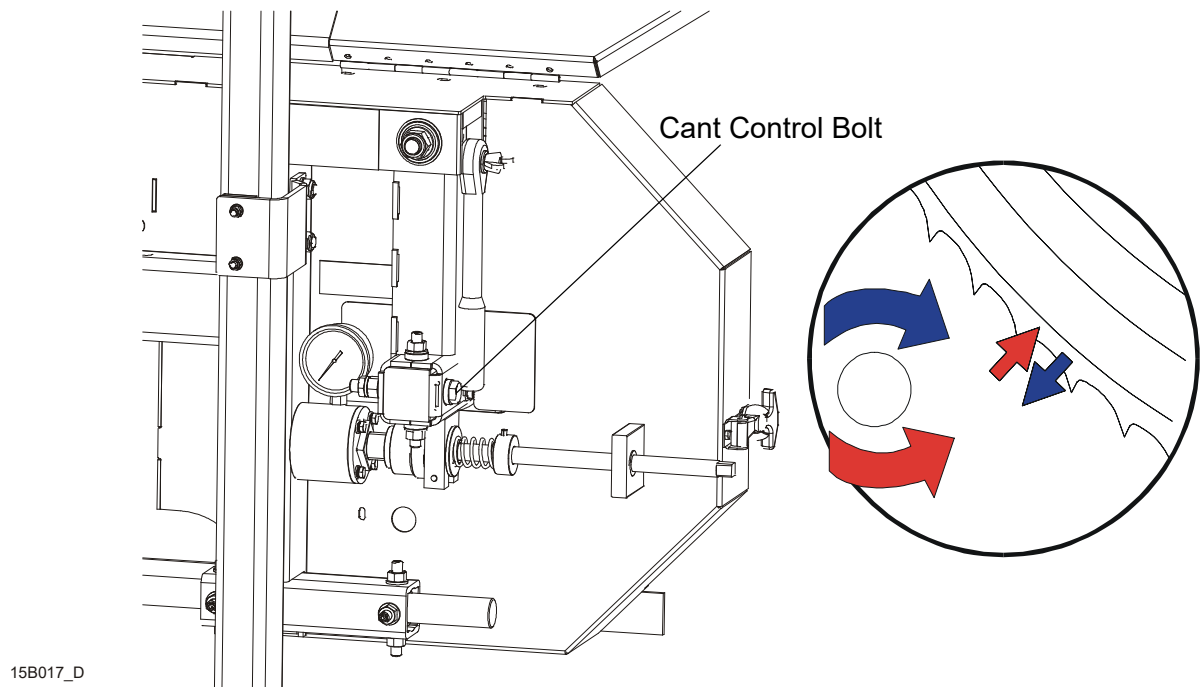

FIG. 3-13

If the blade is too far out, back the blade onto the wheel by turning the cant control counterclockwise. If the blade is too far in, turn the cant control clockwise until the gullet of the blade is the correct distance from the front edge of the wheel.

6. Adjust the blade tension if necessary to compensate for any changes that may have occurred while adjusting the cant control.
7. Close the blade housing cover.

! **DANGER!** Make sure all guards and covers are in place and secured/closed before operating the sawmill. Failure to do so may result in serious injury.

IMPORTANT! After aligning the blade on the wheels, always double-check the blade guide spacing and location. ([See SECTION 6](#) for more information.)

3.5 Starting The Motor

See the appropriate manual supplied with your specific motor configuration for starting and operating instructions.



IMPORTANT! When starting the machine for the first time, check that main motor rotation direction is as indicated by the arrow located on the motor body (fan guard). If the rotation direction is incorrect, invert the phases in the phase inverter located in the power socket (electric box). Setting the phases in the phase inverter correctly will ensure correct rotation directions of all sawmill motors.



DANGER! Make sure all guards and covers are in place and secured/closed before operating the sawmill. Failure to do so may result in serious injury.

DANGER! Always be sure the blade is disengaged and all persons are out of the path of the blade before starting the engine or motor. Failure to do so will result in serious injury.



WARNING! Always wear eye, ear, respiration, safety clothing and foot protection when operating the sawmill. Failure to do so may result in serious injury.

3.6 Starting The Engine

See the appropriate manual supplied with your specific engine configuration for starting and operating instructions.



DANGER! Make sure all guards and covers are in place and secured before operating the sawmill. Failure to do so may result in serious injury. Be sure the blade housing and pulley covers are in place and secure.

DANGER! Always be sure the blade is disengaged and all persons are out of the path of the blade before starting the engine or motor. Failure to do so will result in serious injury.



WARNING! Always wear eye, ear, respiration, and foot protection when operating the sawmill. Failure to do so may result in serious injury.



CAUTION! If at any time you need to immediately stop the blade engine, press emergency stop button located on the operator's panel.

See Figure 3-14.

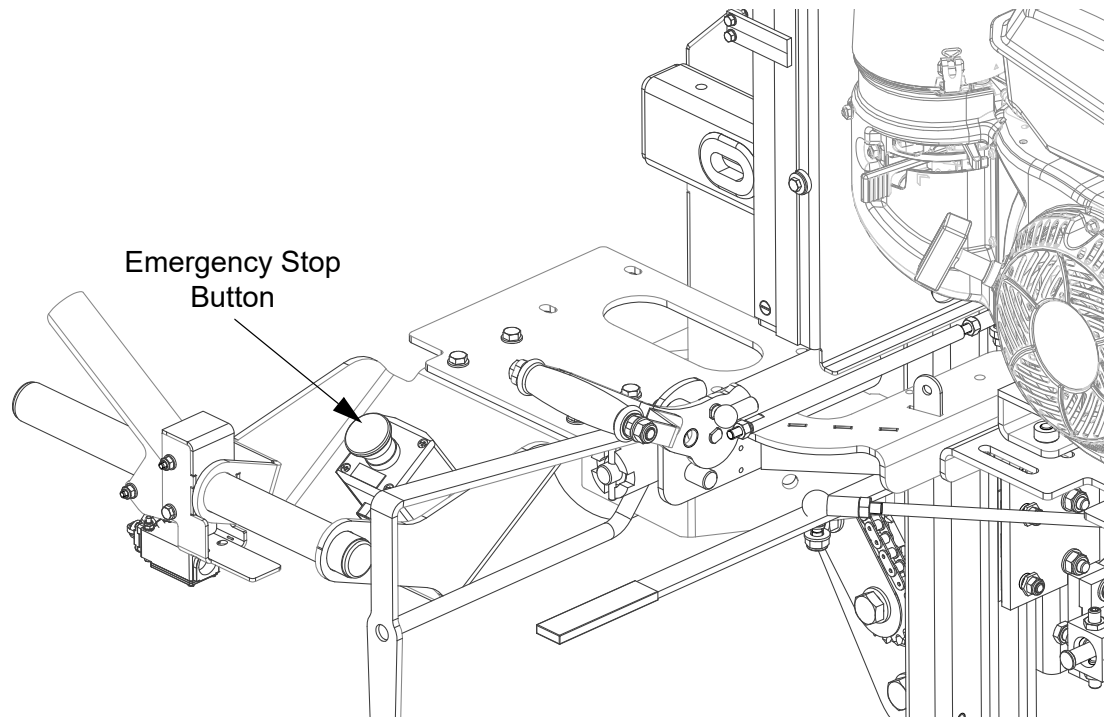

FIG. 3-14

3.7 Loading, Turning, And Clamping Logs

To Load Logs

1. Move the cutting head to the front end of the frame.



CAUTION! Before loading a log, be sure the cutting head is moved far enough forward so the log does not hit it. Failure to do so may result in machine damage.

2. Adjust the log clamps all the way down and move them toward the loading side of the sawmill frame.



CAUTION! Be sure the log clamps are all the way down before loading a log onto the bed. Failure to do so may result in machine damage.

3. Raise the side supports on the sawmill bed to prevent the log from falling off the side of the bed.
4. Place the optional loading ramps (optional equipment) in the frame brackets that will evenly support the length of the log.
5. Position the log at the foot of the ramps.
6. Use a cant hook to roll the log up the ramps and onto the sawmill bed. Position the log against the side supports.
7. Remove the log ramps and set aside.



CAUTION! The saw head will hit the spring-loaded ramp stops when adjusted for low cuts. Remove the loading ramps before sawing to prevent damage to the saw head and/or blade guide arm.

If you did not purchase the optional loading ramps, use boards for ramps or use log loading equipment to load the log on the sawmill bed.

To Turn Logs

1. Use a cant hook to spin the log against the side supports until it is turned the way you want it for the first cut.

To Clamp Logs

1. Position the clamps against the log, far enough down so they are below your cuts on a given side of the log. Using the clamp handles move the log firmly against the side supports.

See Figure 3-15.

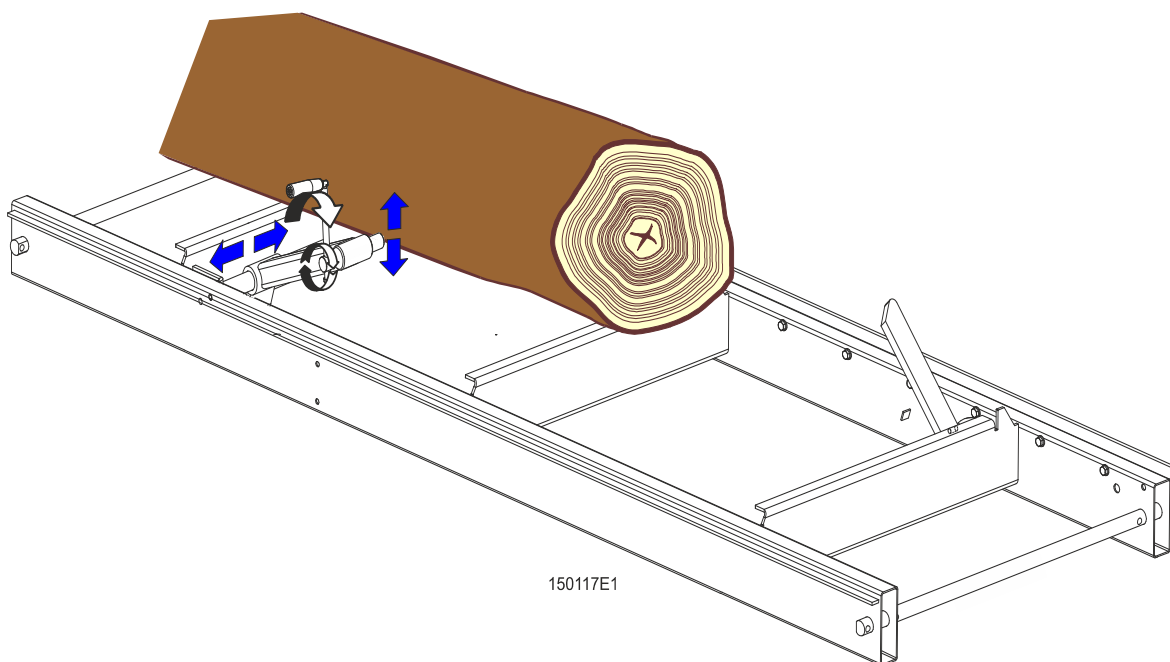

FIG. 3-15

2. Be sure to leave crank in the bottom position to avoid damage to the blade.

See Figure 3-16.

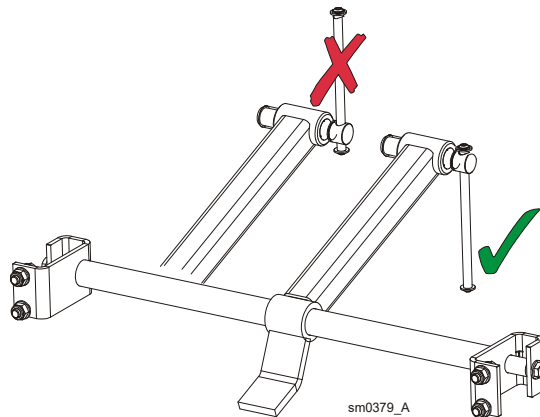

FIG. 3-16

3. Make sure the side supports are positioned low enough for the blade to pass over them. If they are not, back the clamps off slightly and push the side supports down until they are positioned below the height of your last cut on a given side of the log.

To Level A Tapered Log

Use shims or the optional wedge to raise either end of a tapered log, if desired.

Shim one end of the log until the heart of the log measures the same distance from the bed rails at each end of the log.

See Figure 3-17.

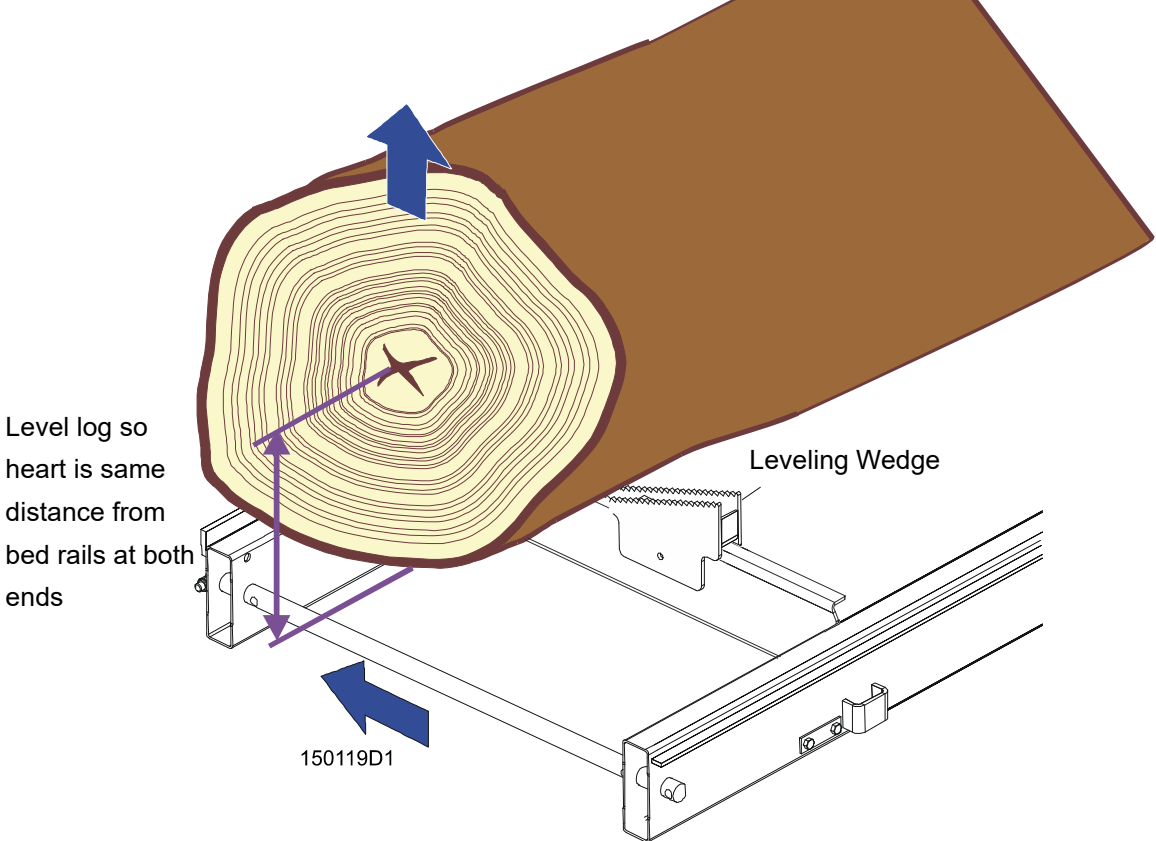

FIG. 3-17

Optional manual toe board. If adjustment is necessary, mount the crank in the toe board fixture at the end of a log to be raised. Turn the crank clockwise to raise the end of the log. Raise the appropriate end of the log until the distance from the heart of the log to the bed rail is equal on both sides.

See Figure 3-18.

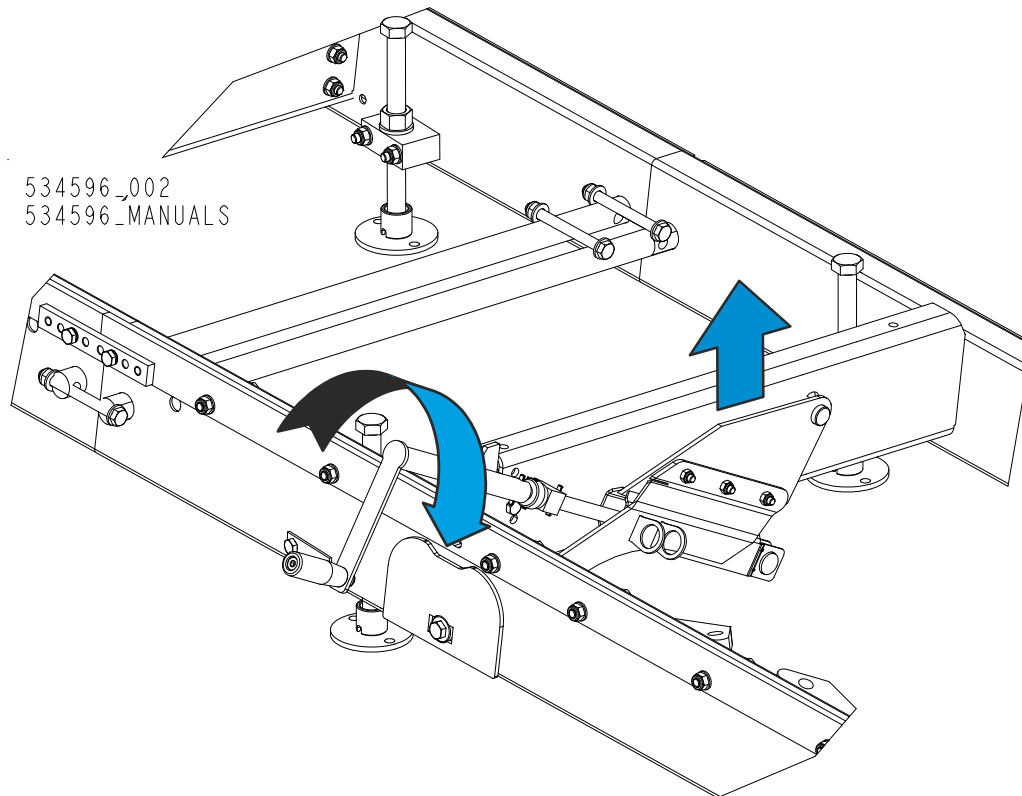

FIG. 3-18

3.8 Manual Up/Down Operation

1. Install a blade, if needed, and check for correct blade tension. ([See Section 3.3](#))

Set the cutting head to the desired height. (The blade height scale shows the height of the blade above the bed rails.)

See Figure 3-19. Use the up/down crank to raise or lower the cutting head.

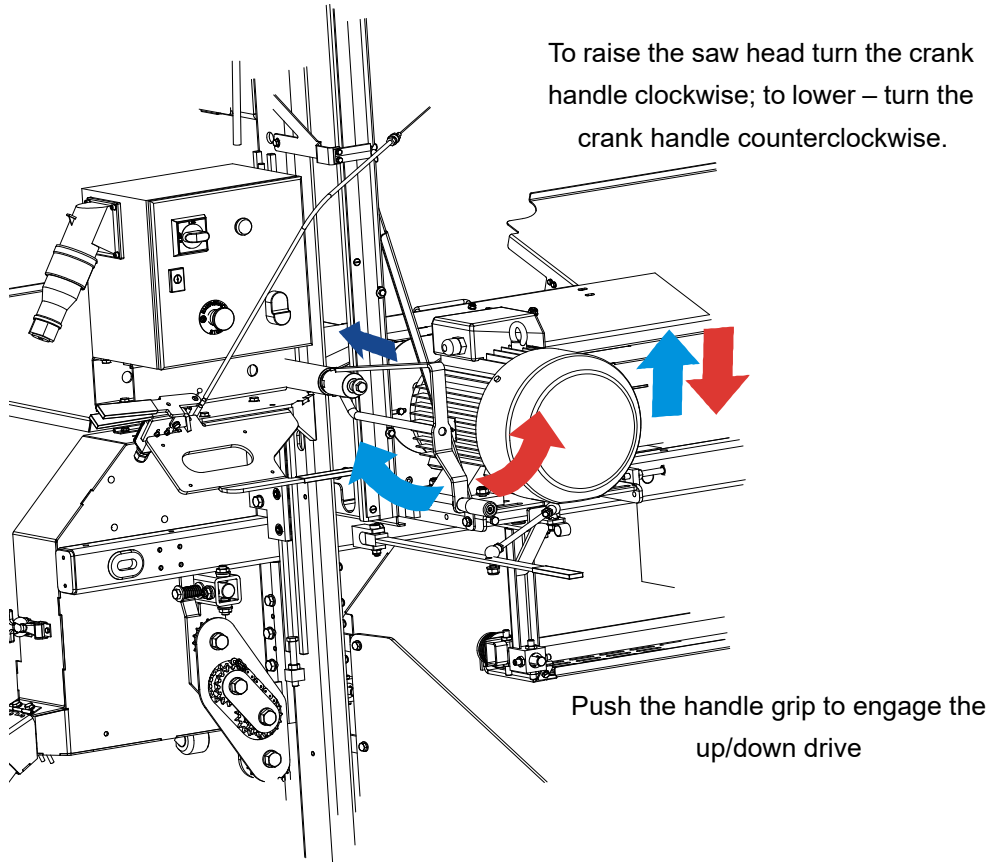

FIG. 3-19

2. Pull the crank grip to lock it in the locking pins.
3. To raise the saw head, turn the up/down crank handle clockwise; to lower – turn the crank handle counterclockwise.

WARNING! DO NOT try to force the carriage above the 27" (68 cm) mark or below the 1" (2.54 cm) mark. Damage to the up/down system may result.

3.9 Up/Down Operation (Option with Electrical Up/Down System)

1. Install a blade, if needed, and check for correct blade tension. ([See Section 3.3.](#))

Set the cutting head to the desired height. (The blade height scale shows the height of the blade above the bed rails.)

See Figure 3-20. Use the up and down buttons shown below to raise or lower the cutting head.

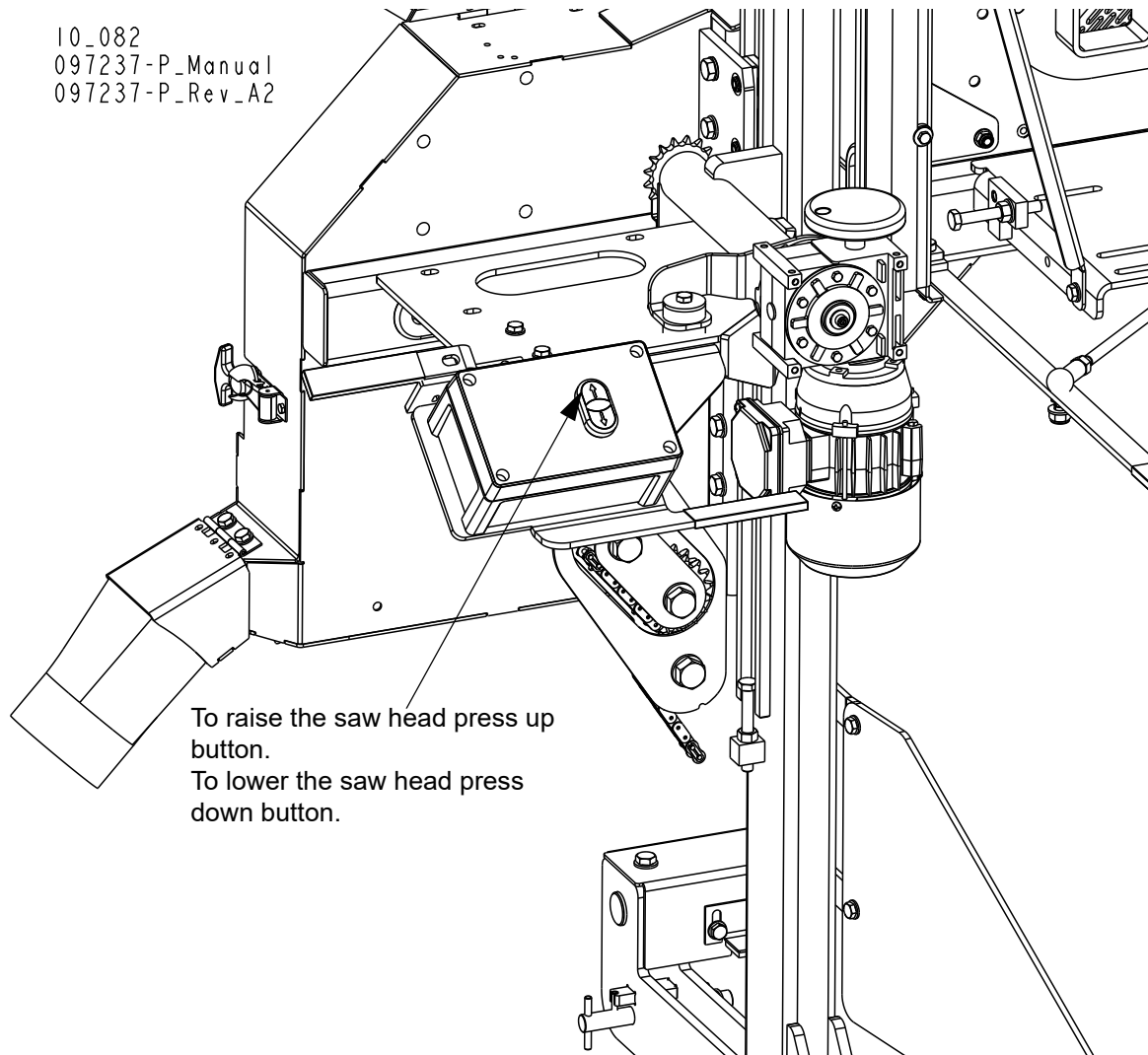

FIG. 3-20



CAUTION! DO NOT try to force the carriage above the 27" (68 cm) mark or below the 1" (2.54 cm) mark. Damage to the up/down system may result.

3.10 Blade Guide Arm Operation

1. Look down the length of the log to see its maximum width. The outer blade guide roller should be adjusted to clear the widest section of the log by less than 1" (25.4 mm).
2. Use the blade guide arm handle to adjust the outer blade guide as necessary. Move the blade guide arm handle right to move the arm out. Move the handle left to move the arm in.

See Figure 3-21.

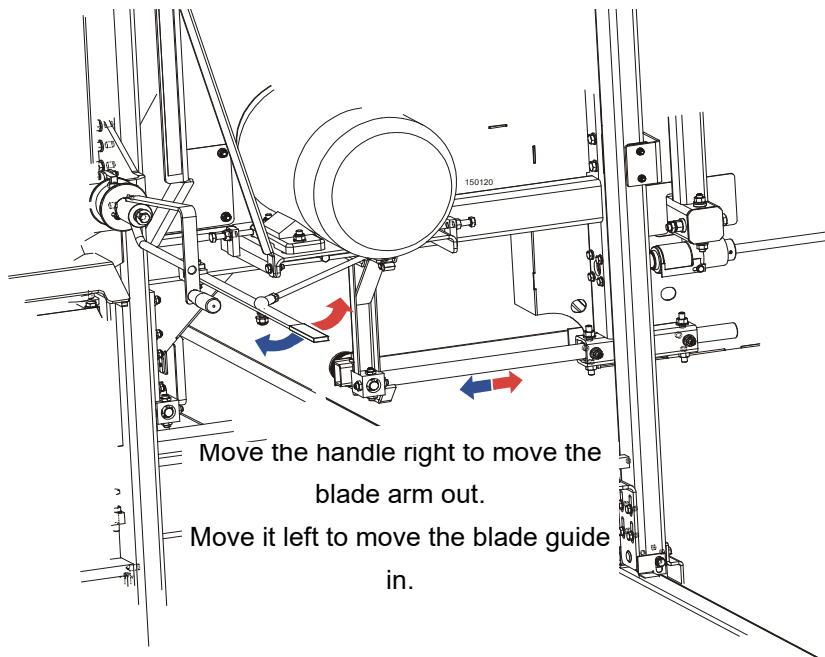

FIG. 3-21

3.11 Blade Drive Operation

IMPORTANT! When starting the machine for the first time, check that main motor rotation direction is as indicated by the arrow located on the motor body (fan guard). If the rotation direction is incorrect, invert the phases in the phase inverter located in the power socket (electric box). Correct motor rotation direction is indicated by the arrow located on the motor body.

DANGER! Make sure all guards and covers are in place and secured/closed before operating the sawmill. Failure to do so may result in serious injury.

WARNING! Always wear eye, ear, respiration and foot protection when operating the sawmill. Failure to do so may result in serious injury.

Be sure the blade housing cover is in place and secured before starting the engine or motor. Use the rubber latches to fasten the blade housing cover shut. If the blade housing cover is not closed and secured, the safety switch located on it interrupts the ignition circuit and the motor/engine cannot be started. If the cover is opened during the mill operation, the engine/motor will be stopped.

To engage the blade, perform the following steps (sawmills with electric blade drive motor):

1. Clear any loose objects from the area of the blade, motor, and drive belt.
2. Make sure the clamps and side supports are positioned low enough for the blade to pass over them. Make sure the log is clamped securely.

3. Turn the main switch on the electrical box to the ON position, and check if the red safety button is released.
4. Press AND HOLD the safety handle on the control box. **NOTE:** If the safety handle is released, the blade disengages and stops.
5. Press the START button on the control box to start the motor.

See Figure 3-22.

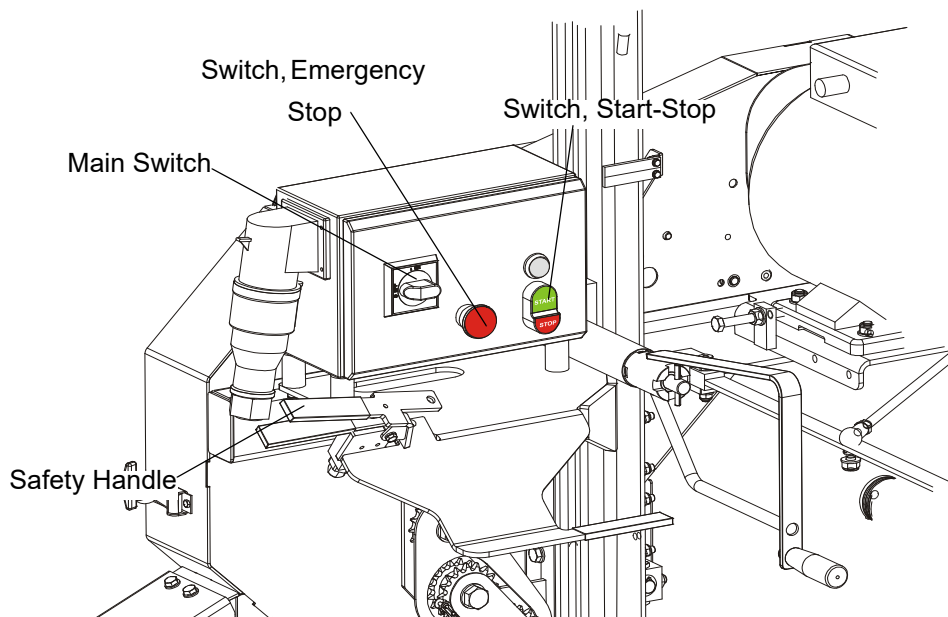

FIG. 3-22



CAUTION! If at any time you need to immediately stop the blade motor, press the emergency stop button located on the electric box.

To engage the blade, perform the following steps (sawmills with gas blade drive engine):

1. Clear any loose objects from the area of the blade, motor, and drive belt.
2. Make sure the clamps and side supports are positioned low enough for the blade to pass over them. Make sure the log is clamped securely.
3. Check if the red emergency stop button is released.
4. Press AND HOLD the safety handle on the control box (CE version only). **NOTE:** If the safety handle is released, the engine will not start.
5. Start the engine. Refer to the G14 Engine Manual supplied for more information.

See Figure 3-23.

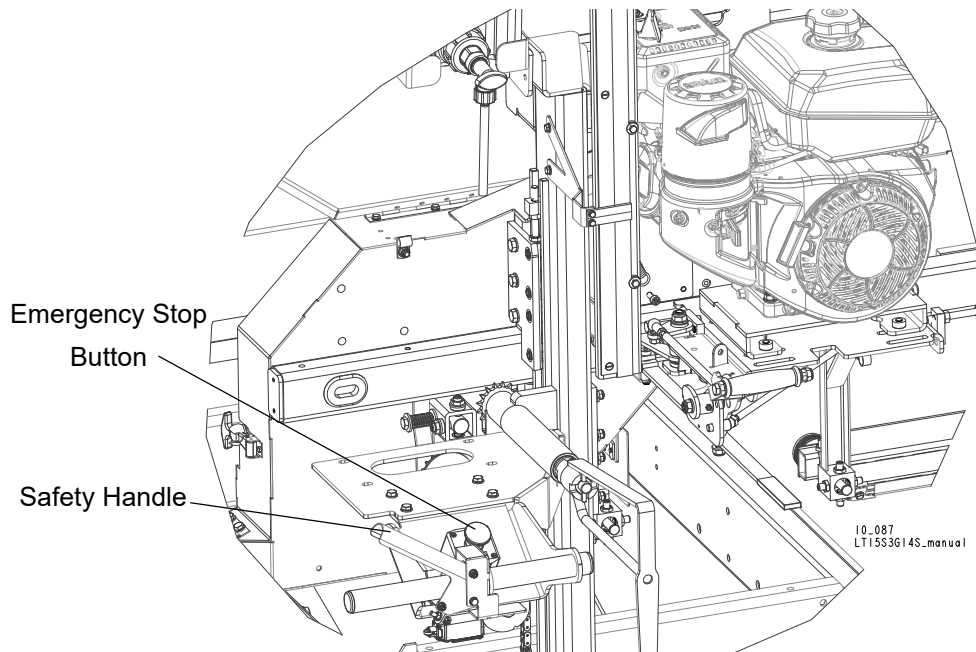



FIG. 3-23

 **CAUTION!** If at any time you need to immediately stop the blade engine, press the emergency stop button located on the operator's panel.

3.12 Feed Operation

To move the saw head, use the two handles located on the electric box bracket.

HINT: To get a straight cut in the first part of the board, feed the blade into the log at a slow speed. This stops the blade from flexing and dipping up or down. Use a slow speed until the whole width of the blade has entered the cut. Then increase the feed rate as desired. Maximum feed rate varies with width and hardness of the wood. Over-feeding results in blade and drive belt wear.

 **CAUTION!** Be sure to stop the blade when returning the cutting head. This will not only prevent the blade from being pulled off and ruined by a wood sliver, but also will increase the life of the blade.

HINT: Try to stop the blade while the heel of the blade is still on the log. Then bring the carriage back without adjusting the blade up. This lets you keep the blade at the current height setting so you can make the next blade height adjustment more quickly.

IMPORTANT! Secure the saw head when loading, turning or clamping the log. Use the transporting lock pin as described in [Section 3.17](#).

3.13 Cutting The Log

The following steps guide you through normal operation of the Wood-Mizer sawmill.

1. Once the log is placed where you want it and clamped firmly, position the blade close to the end of the log.
2. Use the blade height scale to determine where to make your first cut ([See Section 3.15](#)). Set the blade to the desired height with the up/down crank handle. Make sure that the blade will clear all side supports and clamps. Adjust the outer blade guide (See Section 3.8).
3. Make sure all covers and guards are in place and secured. Start the engine.
4. Start the water lube if necessary to prevent sap buildup on the blade ([See Section 3.16](#)).
5. Feed the blade into the log slowly. Once the blade completely enters the log, increase the feed rate as desired. Always try to cut at the fastest speed you can while keeping an accurate cut. Cutting too slowly will waste blade life and lower production!
6. As you get to the end of the log, slow down the feed rate. When the teeth exit the end of the log, release the safety handle on the control box. Remove the slab that you have just cut from the log.
7. Use the feed crank to return the cutting head to the front of the mill. Always disengage the blade before returning the cutting head for the next cut.
8. Repeat until the first side of the log is cut as desired. Set aside the usable flitches (boards with bark on one or both sides). You can edge them on the mill later.
9. Remove the leveling wedge if it was used. Release the clamps and turn the log 90 or 180 degrees. Make sure the flat on the log is placed flat against side supports if turned 90 degrees. Make sure it is placed on bed rails if turned 180 degrees. If the log was turned 90 degrees and you are using the wedge to compensate for taper in the log, use the wedge again to adjust the heart of the log parallel with the bed.
10. Repeat the steps used to cut the first side of the log until the log is square. Cut boards from the remaining cant.

Example: Remember that the blade cuts a 1/16 - 1/8" (1.6 - 3.2 mm) wide kerf. If you want 1" (25 mm) thick boards, lower the carriage 1 1/16 - 1 1/8" (27 - 29 mm) for each board.

3.14 Edging

The following steps guide you through edging boards on the Wood-Mizer sawmill.

1. Raise the side supports to 1/2 the height of the flitches, or the boards that need to be edged.
2. Stack the flitches on edge against the side supports.
3. Clamp the flitches against the side supports halfway up the flitch height. (Wider flitches should be placed to the clamp side. When they are edged, flip them over to edge the second side without disturbing the other flitches.)
4. Adjust the blade height to edge a few of the widest boards.
5. Loosen the clamps and turn the edged boards over to edge the other side.
6. Repeat steps 2-4.
7. Loosen the clamps and remove the boards that have good clean edges on both sides. Clamp the remaining flitches and repeat steps 2-5.

3.15 Blade Height Scale

See Figure 3-24. The blade height scale is mounted on the vertical mast. It includes:

- a blade height indicator
- centimeter scale (or quarter inch scale)

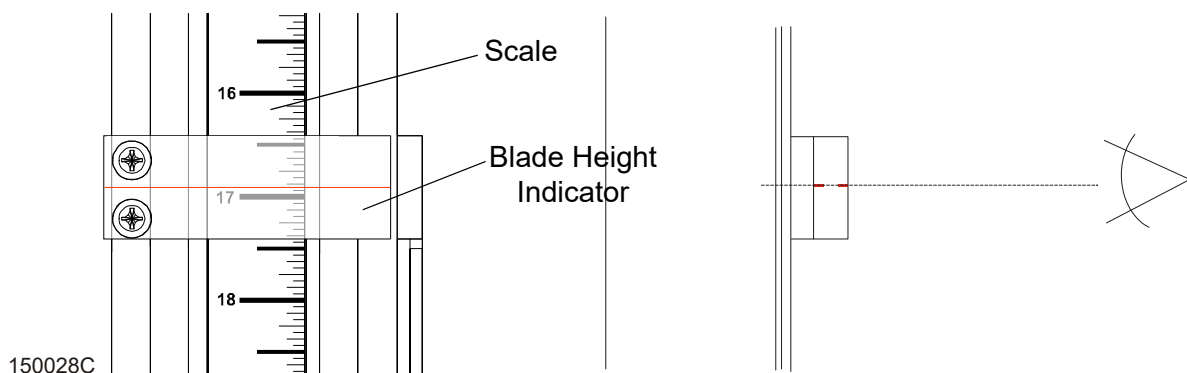

FIG. 3-24

Blade Height Indicator

The blade height indicator has two horizontal, red lines on both sides. Readings should be taken with eyes level with the indicator, when the two red lines are in line. This will allow to avoid the parallax error (different scale readings depending on the angle of vision).

The Scale

The horizontal red line on the blade height indicator shows how many centimeters the bottom of the blade is above the bed of the mill. If you know the height of your blade at each cut, you can determine the thickness of lumber you are sawing.

Example: You want to cut 25 mm random width boards from a log. Position the blade for the first cut. Move the carriage to an even measurement on the scale. Make a trim cut. Return the carriage for the second cut and lower it 29 mm below the original measurement. (The extra 3 mm allows for saw kerf and shrinkage of the lumber.)

The yellow area on the scale identifies where the blade could encounter a side support or log clamp. Check that these items are below the blade level before sawing.

The Quarter Scale

See Table 3-3. The quarter scale contains of four sets of marks. Each set represents a specific lumber thickness. Saw kerf and shrinkage allowance are included, but actual board thickness will vary slightly depending on blade thickness and tooth set.

To choose which scale to use, determine what finished thickness you want to end up with. The Grade Hardwood Quarter Scale provides thicker finished boards usually required by commercial buyers. The Standard Quarter Scale allows for kerf and shrinkage of finished boards suitable for most custom applications. Always check with your customer before you saw to determine what actual finished thickness is required.

Standard Quarter Scale		Grade Hardwood Quarter Scale	
Scale	Actual Board Thickness	Scale	Actual Board Thickness
4/4	25 mm (1")	4/4	29 mm (1 1/8")
5/4	32 mm (1 1/4")	5/4	35 mm (1 3/8")
6/4	38 mm (1 1/2")	6/4	41 mm (1 5/8")
8/4	51 mm (2")	8/4	54 mm (2 1/8")

TABLE 3-3

To use the quarter scale, look at the blade height indicator. **Example:** You want to cut 1" (25 mm) (4/4) random width boards from a log. Position the blade for the first cut. Make a trim cut. Return the carriage for the second cut. Now, instead of having to measure down 1 1/8" (29 mm) on the inch scale, you can simply lower the blade so the indicator is aligned with the next 4/4 mark on the quarter scale. Turn the log 90 degrees and repeat.

3.16 Water Lube Operation

The Water Lube System keeps the blade clean. Water flows from a 5 liter bottle through a hose to the blade guide where the blade enters the log. A valve in the bottle cap controls the amount of water flow.

See **Figure 3-25**. Install the water bottle at the top of the vertical mast.

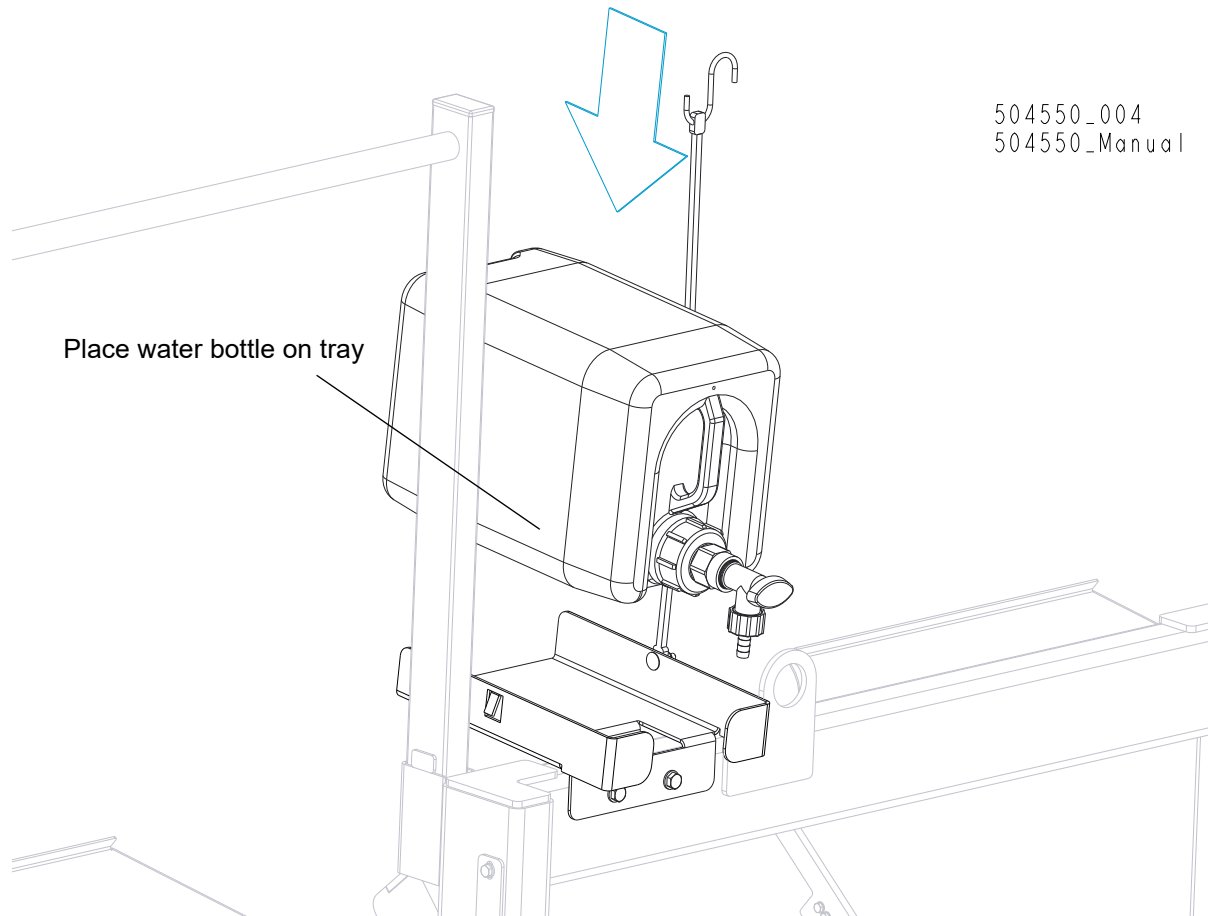

FIG. 3-25

See **Figure 3-26**. Open the valve on the water bottle to start water flow on the blade.

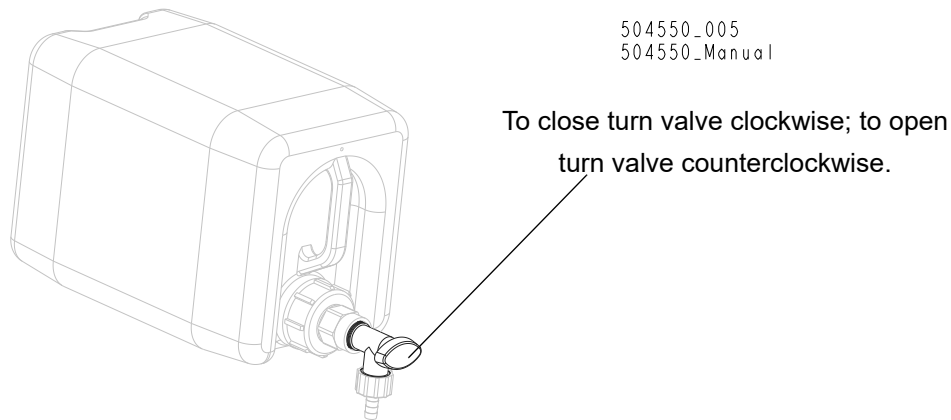

FIG. 3-26

Not all types of wood require the use of the Water Lube System. When it is needed, use just enough water to keep the blade clean. This saves water, and lowers the risk of staining the boards with water. Usual flow will be 1-2 gallons (3.8-7.6 liters) per hour. A squirt of liquid dishwashing detergent in the water bottle will help clean the blade when cutting wood with a high sap content.



WARNING! Use ONLY water with the water lube accessory. Never use flammable fuels or liquids. If these types of liquids are necessary to clean the blade, remove it and clean with a rag. Failure to do so may result in serious injury or death.

Before removing the blade, engage blade drive. Let the blade spin with water running on it for about 15 seconds. This will clean the blade of sap buildup. Wipe the blade dry with a rag before storing or sharpening.

If you are sawing in freezing temperatures, remove the water lube bottle from the sawmill when done sawing and store it in a warm place. Blow any remaining water from the water lube hose.

3.17 Transporting the Sawmill

The assembled sawmill can be transported in an appropriately equipped pickup truck:

1. Adjust the cutting head up just far enough so it will clear the sides of your truck bed when loaded. Do not adjust the cutting head so high that the sawmill will tip easily while being loaded.
2. Move the cutting head to one end of the bed frame. Engage the travel lock pin to prevent the cutting head from moving. Pull the pin and rotate and release so the roll pin seats in the locking position notch.

See Figure 3-27.

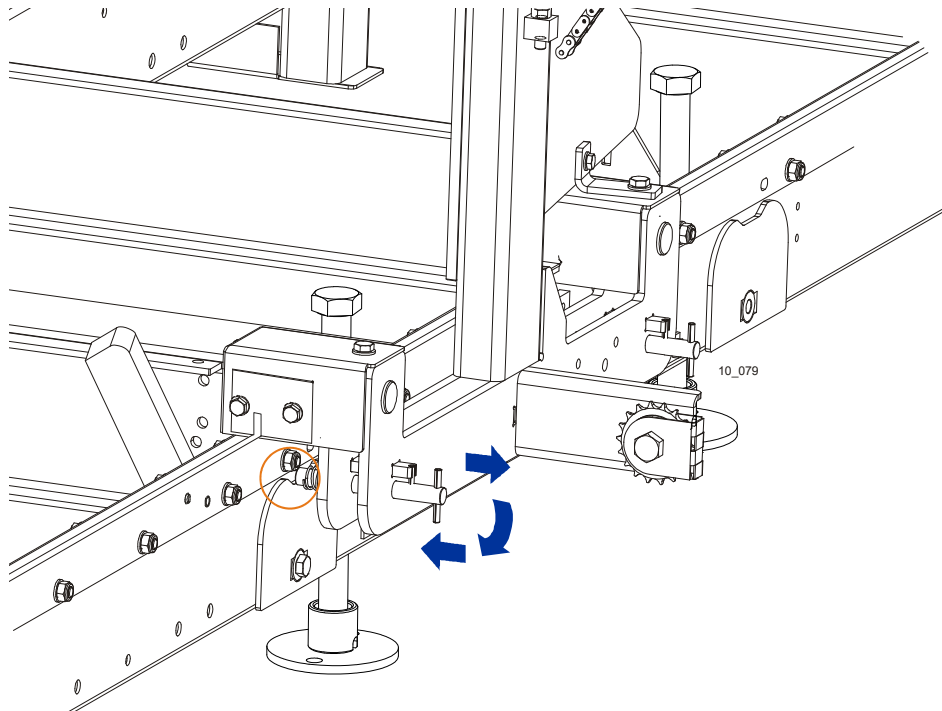



FIG. 3-27

3. Remove the leg assemblies or adjust them above the bottom of the bed frames.
4. Position the bed of the truck at the end of the frame opposite the cutting head.
5. While two people lift the end of the frame without the cutting head, back the truck under the sawmill until the the end of the frame is resting firmly on the bed of the truck.
6. With a person positioned on either side of the cutting head, disengage the travel lock pin. Push the cutting head up the bed frame and engage the travel lock pin in the end of the frame in the truck bed.
7. Use two people to lift the end of the mill still on the ground and slide the sawmill into the truck bed.

 **WARNING!** Keep all persons out of the path of the cutting head while loading and unloading the sawmill. Failure to do so may result in serious injury or death.

8. Secure the sawmill to the truck bed to prevent the sawmill from shifting while it is being transported.

SECTION 4 MAINTENANCE

This section lists the maintenance procedures that need to be performed on the LT15SA sawmills.

The Short Interval Maintenance Schedule lists procedures that need to be performed every 4, 8 or 25 hours. The Maintenance Log lists procedures that need to be performed every 50, 100, 200, or 1000 hours. Keep track of machine maintenance by filling in the machine hours and the date you perform each procedure.



This symbol identifies the interval (hours of operation) which each maintenance procedure should be performed.

4.1 Wear Life

See Table 4-1. This chart lists estimated life expectancy of common replacement parts if proper maintenance and operation procedures are followed. Due to the many variables which exist during sawmill operation, actual part life may vary significantly. This information is provided so that you may plan ahead in ordering replacement parts.

Part Description	Estimated Life
B57 Blade Wheel Belts	500 hours
Blade Guide Rollers	1000 hours
Drive Belt	1250 hours

TABLE 4-1

4.2 Sawdust Removal

Remove the excess sawdust from the blade wheel housing and sawdust chute every blade change.

4.3 Carriage Track & Rollers

See Figure 4-1.



1. Clean the track bar to remove any sawdust and sap buildup every eight hours of operation.
2. Remove sawdust from the track roller housings. Remove the track roller housing covers and brush

any sawdust buildup from the housings.

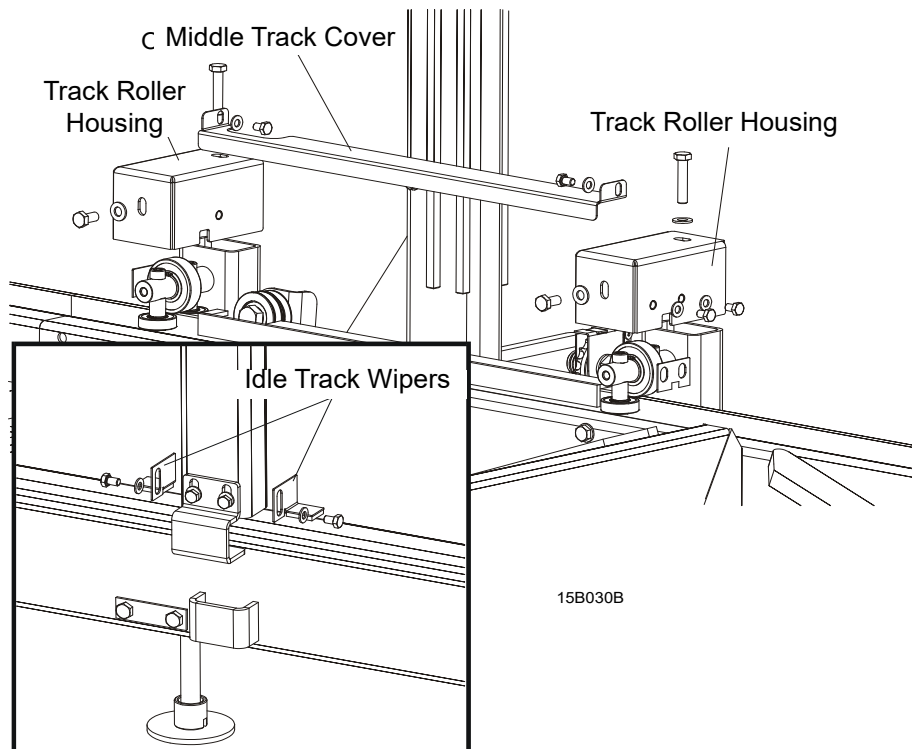

FIG. 4-1

4.4 Vertical Mast Rails

50

Clean and lubricate the vertical mast rails every 50 hours of operation. Clean with solvent and remove any rust with a light-grade sand paper. Lubricate the mast with motor oil or automatic transmission fluid (e.g. Dextron II or Dextron III).



CAUTION! Never use grease on the mast rails as it will collect sawdust.

4.5 Miscellaneous Lubrication

1. Lubricate the tensioner screw and up/down crank handle shaft with a rolling bearing grease (e.g. LT4S or Shell Extreme Pressure Grease) as needed.

See Figure 4-2.

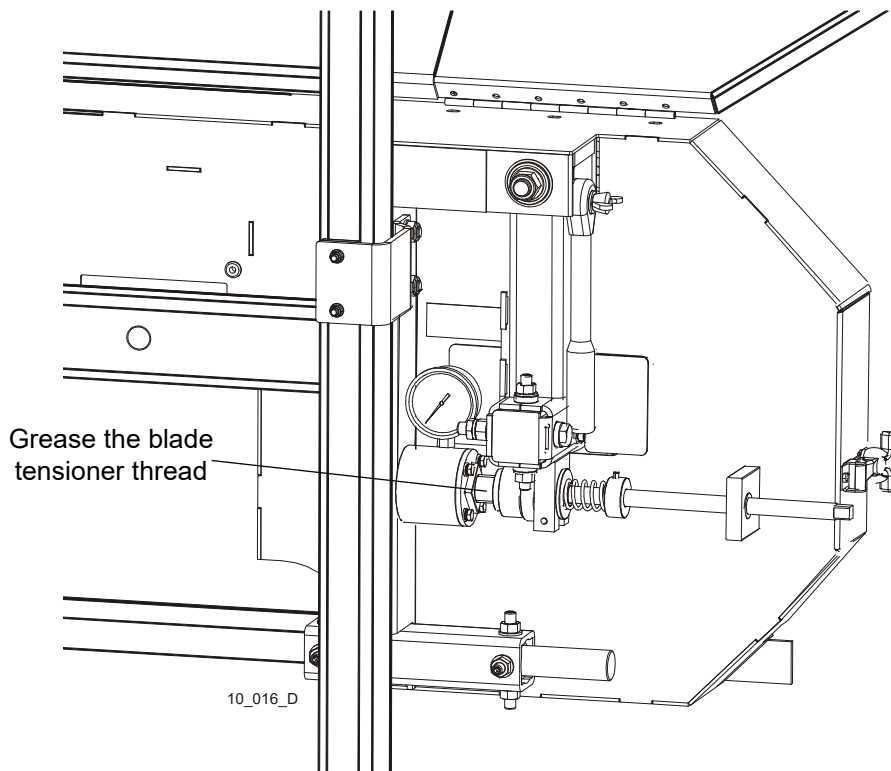

FIG. 4-2

4.6 Blade Wheel Belts

1. Check the blade wheel belts for wear. Replace belts as necessary. Rotating the belts every 50 hours will give you longer belt life. Use only B57 belts manufactured by Goodyear or Browning.
2. Periodically check all belts for wear. Replace any damaged or worn belts as needed.

50

4.7 Up/Down System

1. Adjust the up/down chain tension as needed. Measure chain tension, with the saw head all the way to the top of the vertical mast. Secure the saw head with a chain at the top or shim it underneath. Find the chain adjusting bolt at bottom part of the mast. Loosen the nut on the bolt and move the sprocket down until there is about 1" (2.5cm) total deflection in the center of the chain with a 5 lb. (2.3kg) deflection force.



WARNING! Always secure the cutting head with a chain or brace before adjusting the up/down chain. The cutting head may fall, causing severe injury or death.

See Figure 4-3.

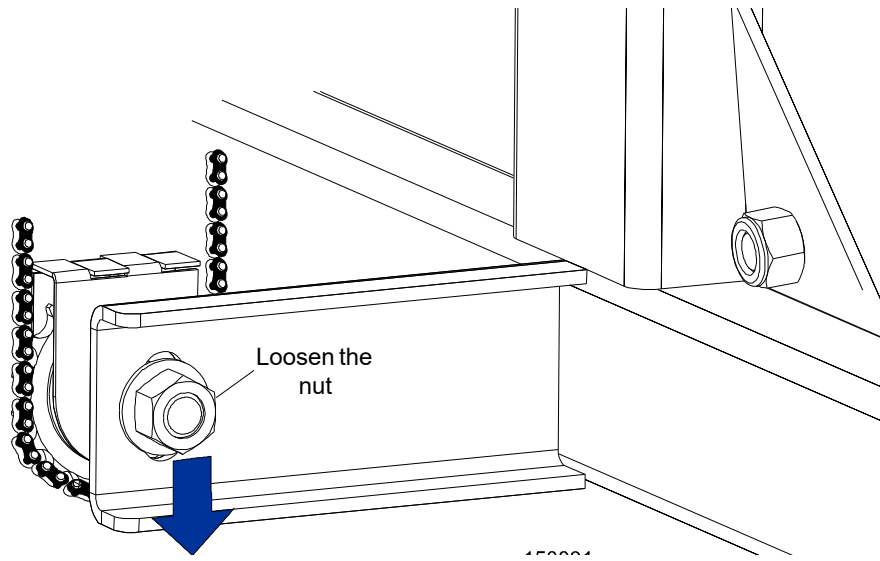

FIG. 4-3

4.8 Miscellaneous Maintenance

1. Check the drive belt tension after the first 20 hours, and every 50 hours thereafter. See Section 6.13 for more informations.
2. Check the mill alignment every setup. See Section 6, Alignment)
3. Make sure all safety warning decals are readable. Remove sawdust and dirt. Replace any damaged or unreadable decals immediately. Order decals from your Customer Service Representative.

4.9 Filling Blade Tensioner Cylinder with Oil

1. Loosen the blade tensioner completely.
2. Unscrew the oil pressure gauge.

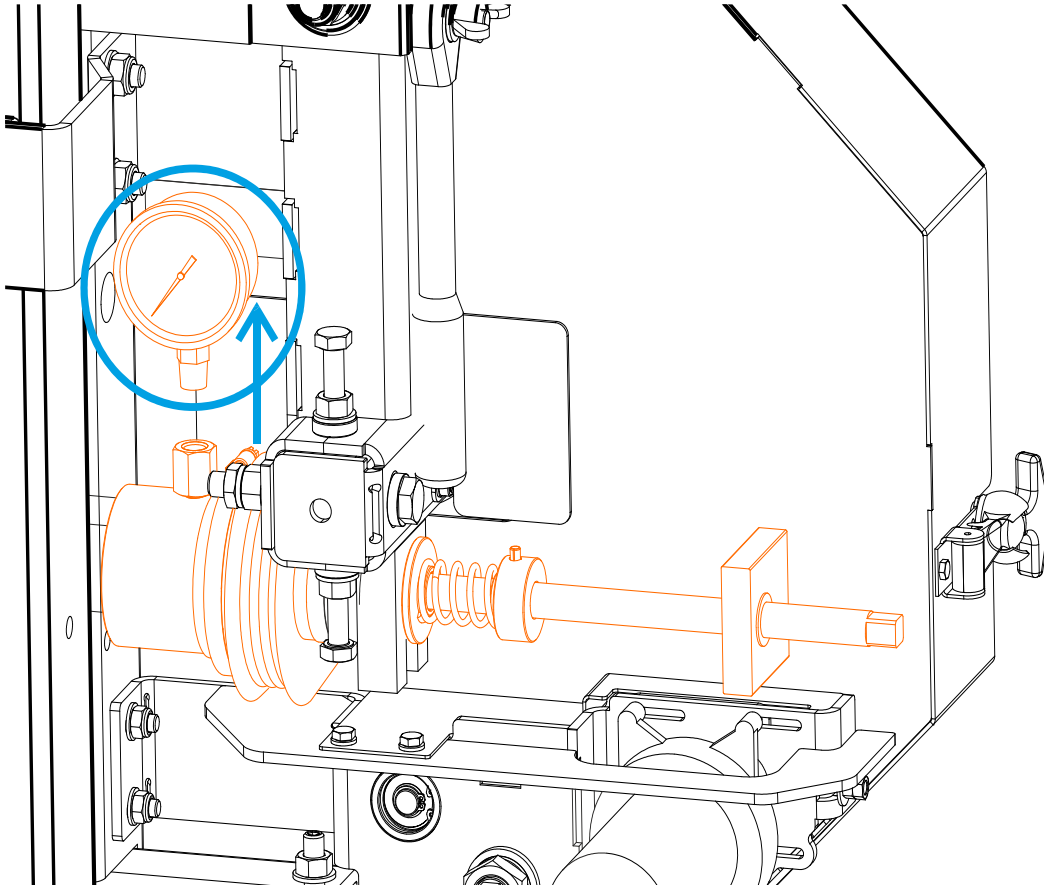

3. Using an oiler equipped with a tube / hose, top up the oil level until the oil flows out of the cylinder.



IMPORTANT! The cylinder needs to be filled with MOBIL DTE 10 Excel 32 Hydraulic Oil (#WM part number: **P12825**).



IMPORTANT! When topping up the oil level, make sure that the end of the oiler tube / hose is at the bottom of the cylinder.

4. Wait 5 minutes. If the oil level does not lower, move on to the next step. If the oil level lowers, top up the oil level until the oil flows out of the cylinder.

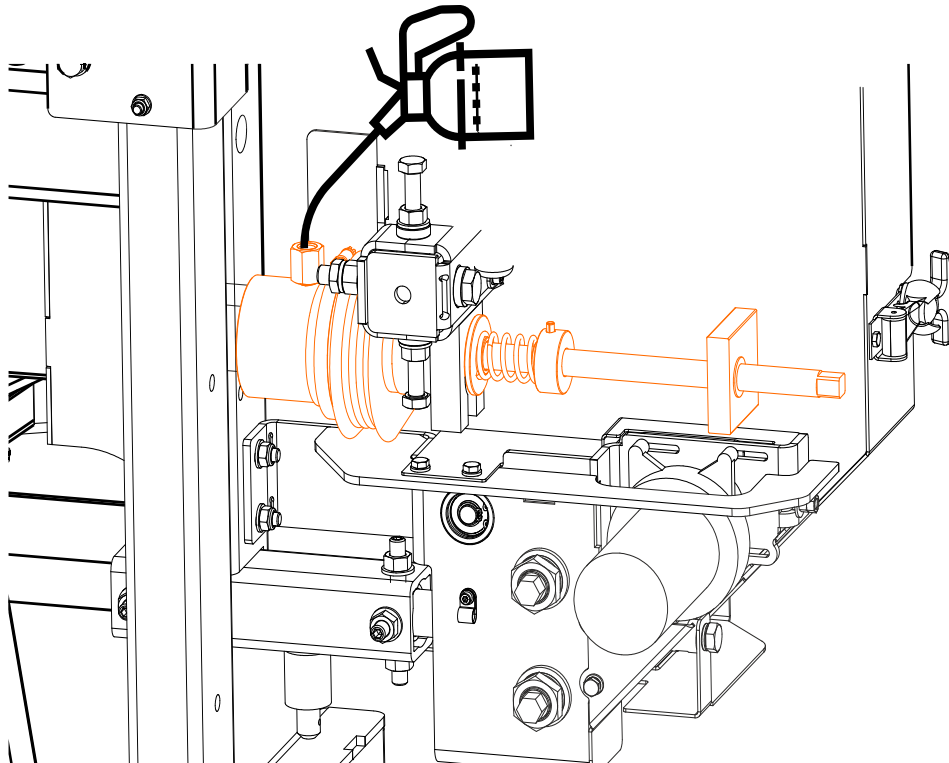

5. Seal the oil pressure gauge with Teflon tape and screw it back.

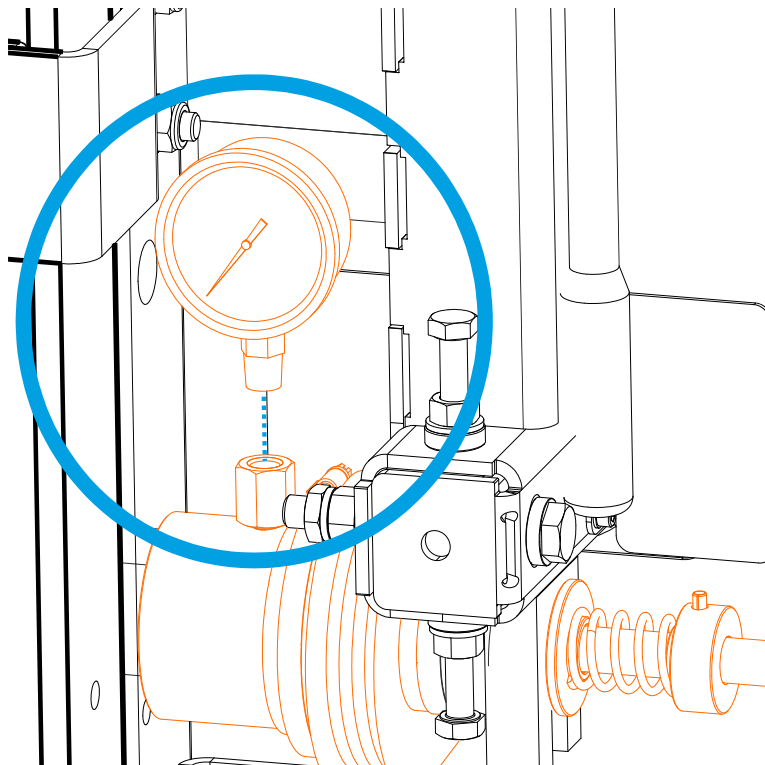

4.10 Safety Devices Inspection (CE version only)

Sawmill with electric blade drive motor – Safety Devices Inspection

Safety devices on the LT15SA/LT15 sawmill which must be checked before every shift:

- E-STOP button and its circuit inspection
- Safety handle and its circuit inspection
- Blade cover safety switches and its circuit inspection.

1. E-STOP button and its circuit inspection

- Press and hold the safety handle;
- Turn on the blade motor;
- Press the E-STOP button located on the control box. The blade motor should be stopped. Pressing the START button shouldn't start the motor until the E-STOP button is released.

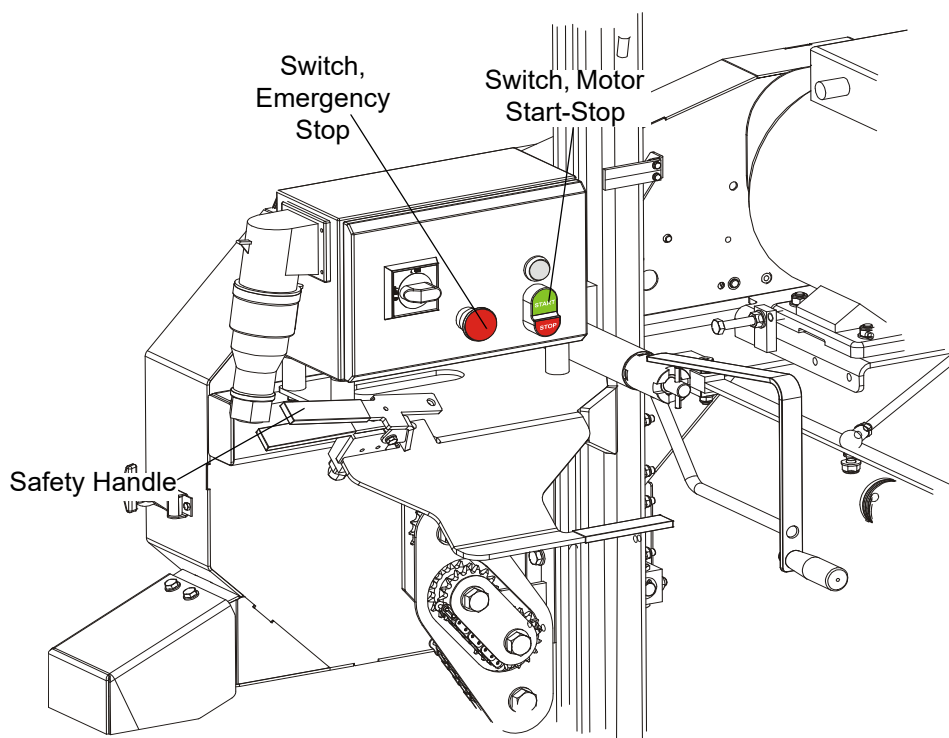

2. Safety handle and its circuit inspection

- Be sure the E-STOP button is released;
- Press and hold the safety handle;

- Turn on the blade motor;
- Release the safety handle. The blade motor should be stopped.
- Press and hold the safety handle. The blade motor should remain stopped.

3. Blade cover safety switch and its circuits inspection

- Press and hold the safety handle;
- Turn on the blade motor;
- Open blade housing cover;
- The blade motor should be stopped;
- Try to start the motor. The blade motor should remain stopped.
- Close the blade housing cover;
- The blade motor should remain stopped until it is restarted with the START button.

Sawmill with gas blade drive engine – Safety Devices Inspection

Safety devices on the LT15SA/LT15 sawmill which must be checked before every shift:

- E-STOP button and its circuit inspection
- Safety handle and its circuit inspection
- Blade cover safety switches and its circuit inspection.

1. E-STOP button and its circuit inspection

- Press and hold the safety handle;
- Start the engine;
- Press the E-STOP button located on the control box. The engine should be stopped. It should not be possible to start the engine until the E-STOP button is released.

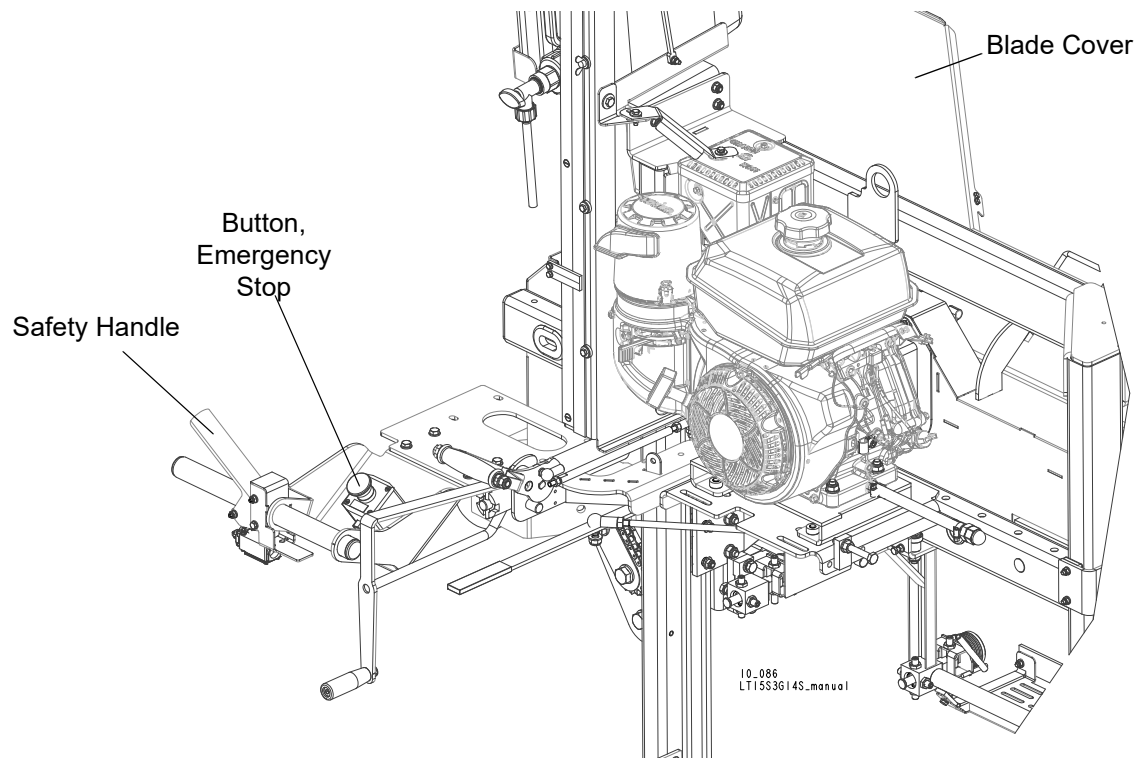

2. Safety handle and its circuit inspection

- Be sure the E-STOP button is released;
- Press and hold the safety handle;
- Start the engine;
- Release the safety handle. The engine should be stopped.

3. Blade cover safety switch and its circuits inspection

- Press and hold the safety handle;
- Start the engine;
- Open blade housing cover;
- The engine should be stopped;
- Try to start the engine. The blade motor should remain stopped.
- Close the blade housing cover.

Wood-Mizer LT15SA/LT15 Short Interval Maintenance Schedule

PROCEDURE	MANUAL REFERENCE
EVERY BLADE CHANGE	
Check Blade Guide Roller Performance	SEE SECTION 4.2
Remove Excess Sawdust From Blade Wheel Housings And Sawdust Chute	SEE SECTION 4.2
EVERY 8 HOURS	
Clean And Lubricate Track	SEE SECTION 4.3
Remove Sawdust From Upper Cam Housings.	SEE SECTION 4.3



WOOD-MIZER LT15SA/LT15 MAINTENANCE LOG

PROCEDURE	MANUAL REFERENCE	TOTAL HOURS OF OPERATION									
		FILL IN THE DATE AND THE MACHINE HOURS AS YOU PERFORM EACH PROCEDURE. A SHADED BOX INDICATES MAINTENANCE IS NOT NEEDED AT THIS TIME.									
		50 HRS	100 HRS	150 HRS	200 HRS	250 HRS	300 HRS	350 HRS	400 HRS	450 HRS	500 HRS
Clean & lubricate mast	See Section4.4										
Check blade wheel belts for wear.	See Section4.6										
Lubricate blade tensioner screw.	See Section4.5										

WOOD-MIZER LT15SA/LT15 MAINTENANCE LOG

PROCEDURE	MANUAL REFERENCE	TOTAL HOURS OF OPERATION									
		FILL IN THE DATE AND THE MACHINE HOURS AS YOU PERFORM EACH PROCEDURE. A SHADED BOX INDICATES MAINTENANCE IS NOT NEEDED AT THIS TIME.									
		550 HRS	600 HRS	650 HRS	700 HRS	750 HRS	800 HRS	850 HRS	900 HRS	950 HRS	1000 HRS
Clean & lubricate mast	See Section4.4										
Check blade wheel belts for wear.	See Section4.6										
Lubricate blade tensioner screw.	See Section4.5										

WOOD-MIZER LT15SA/LT15 MAINTENANCE LOG

PROCEDURE	MANUAL REFERENCE	TOTAL HOURS OF OPERATION									
		FILL IN THE DATE AND THE MACHINE HOURS AS YOU PERFORM EACH PROCEDURE. A SHADED BOX INDICATES MAINTENANCE IS NOT NEEDED AT THIS TIME.									
		1050 HRS	1100 HRS	1150 HRS	1200 HRS	1250 HRS	1300 HRS	1350 HRS	1400 HRS	1450 HRS	1500 HRS
Clean & lubricate mast	See Section4.4										
Check blade wheel belts for wear.	See Section4.6										
Lubricate blade tensioner screw.	See Section4.5										

WOOD-MIZER LT15SA/LT15 MAINTENANCE LOG

PROCEDURE	MANUAL REFERENCE	TOTAL HOURS OF OPERATION									
		FILL IN THE DATE AND THE MACHINE HOURS AS YOU PERFORM EACH PROCEDURE. A SHADED BOX INDICATES MAINTENANCE IS NOT NEEDED AT THIS TIME.									
		1550 HRS	1600 HRS	1650 HRS	1700 HRS	1750 HRS	1800 HRS	1850 HRS	1900 HRS	1950 HRS	2000 HRS
Clean & lubricate mast	See Section4.4										
Check blade wheel belts for wear.	See Section4.6										
Lubricate blade tensioner screw.	See Section4.5										

SECTION 5 TROUBLESHOOTING GUIDE

5.1 Sawing Problems

PROBLEM	CAUSE	SOLUTION
Blades Dull Quickly	Dirty logs	Clean or debark logs, especially on entry side of the cut.
	When grinding teeth, heating too much and causing teeth to soften	Grind just enough metal to restore sharpness to the teeth. Use water/coolant while sharpening blade.
	Poor sharpening techniques	Make sure the tip is being sharpened completely (See Sharpener Manual).
Blades Break Prematurely	Rubber belts on blade wheels worn to a point that blade contacts metal pulley - look for shiny spots on edge of wheels.	Change blade wheel belts (B-57).
	Poor sharpening techniques	See Sharpener Manual.
Blade Does Not Track Right on Wheels	Tension too tight	Tension blade to recommended specifications.
	Cant adjustment is incorrect	Readjust.
Blade Guide Rollers Do Not Spin While Cutting	Flat/worn belts	Replace B-57 belts.
	Frozen bearings	Replace bearings.
	Worn bearings	Replace bearings.
Drive Belts Wear Prematurely or Jump	Engine/motor and drive pulleys out of alignment	Align pulleys.

PROBLEM	CAUSE	SOLUTION
Boards Thick Or Thin On Ends Or Middle Of Board	Stress in log which causes log to not lay flat on the bed	After log has been squared, take equal cuts off opposing sides. Repeat, keeping the heart in the middle of the cant, and making it your last cut.
	Set in teeth	Resharpen and reset blade.
Height Adjustment Jumps or Stutters When Moving Up or Down	Bed rails misaligned	Realign sawmill.
	Mast needs lubrication	Lubricate mast track surface.
	Mast slide pads are not adjusted properly (the entire surface of the pad should touch the mast)	Adjust pads.
Lumber Is Not Square	Sawdust or bark between cant and bed rails	Remove particles.
	Tooth set problems	Resharpen and reset blade.
Sawdust Builds Up On Track	Excessive lubrication	Do not lubricate track with grease.
	Track is sticky	Clean track with solvent and apply silicone spray.
Wavy Cuts	Excessive feed	Slow down feed rate.
	Improperly sharpened blade (This will be the problem 99% of the time!)	Resharpen blade. (See Sharpener Manual - read entire manual!)
	Blade guides improperly adjusted	Adjust blade guides.
	Sap buildup on blade	Remove sap. Use larger amount of water flow to the blade during cutting.
	Tooth set problem	Resharpen and reset blade.

SECTION 6 SAWMILL ALIGNMENT

6.1 Pre-Alignment Procedures

Periodically check the sawmill alignment and adjust if necessary. This chapter explains how to align the entire sawmill. Care should be taken in performing these steps. Sawmill alignment determines the accuracy and squareness of your cuts.

The sawmill alignment steps are:

1. Prepare the sawmill for alignment
2. Adjust the blade parallel to the bed rails
3. Adjust the blade guide arm parallel to the saw head brace
4. Align blade guides to the blade
5. Adjust side supports square to the bed
6. Final Adjustments.

To insure accurate alignment, the sawmill frame must be level and a blade properly installed.

[See SECTION 3 Setup & Operation](#) for setup information.

6.2 Preparing The Sawmill For Alignment

Before performing the following alignment procedures, setup the mill on firm, level ground. String the bed and adjust the legs so the frame is level ([Section 3.1](#)).

6.3 Blade Installation and Alignment

Install a blade and apply the appropriate tension as shown in [Section 3.3](#).

1. Close the blade housing cover and make sure all persons are clear of the open side of the saw head.
2. Start the motor for a moment.



WARNING! Do not spin the blade wheels by hand. Spinning the blade wheels by hand may result in serious injury.

3. Turn off the motor, open the blade housing cover, remove the key from the key switch and check the position of the blade on the blade wheels.

Check the vertical alignment of the idle-side blade wheel. The gullet of the blade should ride the same distance from the front edge of the wheel at the top and bottom of the wheel. If it does not, loosen and tighten the appropriate adjustment screws on the wheel shaft.

See Figure 6-1. The blade wheels should be adjusted so that the gullet of 1 1/4" blades ride 1/8" (3 mm) out from the front edge of the wheels ($\pm 1/26$ [1 mm]). The gullet of 1 1/2" blades should ride 3/16" (4.5 mm) from the front edge of the wheels ($\pm 1/26$ [1 mm]). Do not let the teeth ride on the wheels.

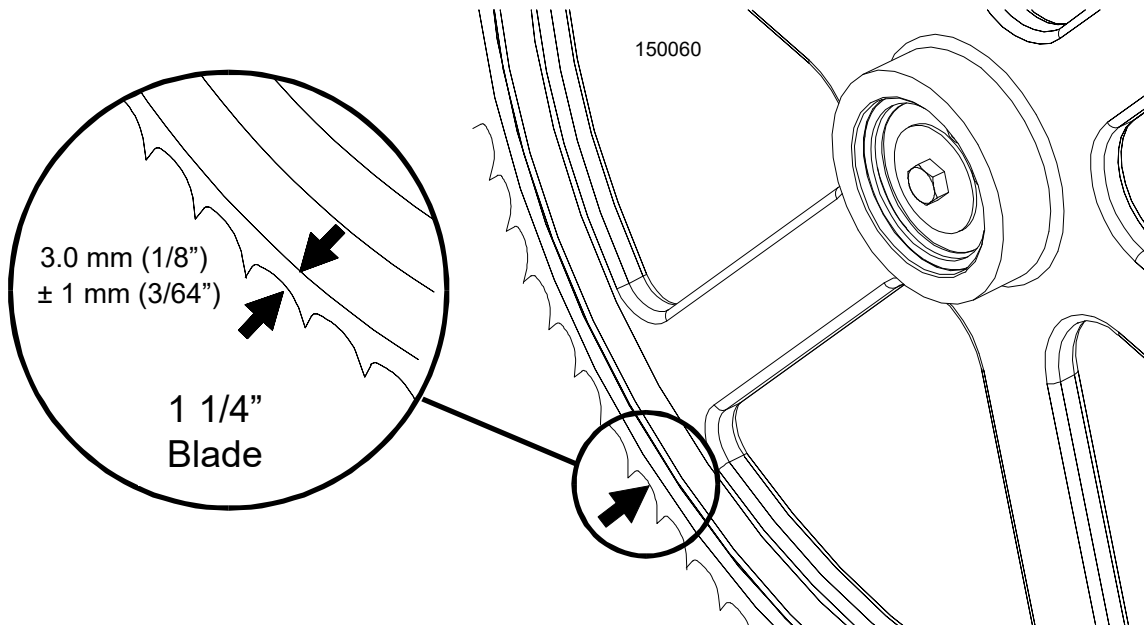

FIG. 6-1

To adjust where the blade travels on the idle-side and drive-side blade wheel, see next section in this manual.

6.4 Blade Wheel Alignment

The blade wheels should be adjusted so they are level in the vertical and horizontal planes. If the blade wheels are tilted up or down, the blade will want to travel in the tilted direction. If the blade wheels are tilted horizontally, the blade will not track properly on the wheels.

Use the blade guide alignment tool to check the vertical alignment of each blade wheel.

1. Attach the tool to the blade near the inner blade guide mount. Be sure the tool does not rest on a tooth or burr, and is lying flat against the bottom of the blade.

See Figure 6-2.

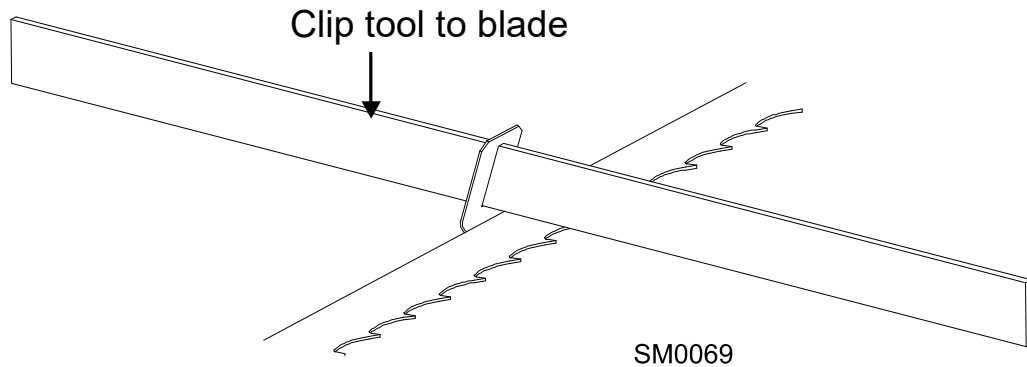

FIG. 6-2

2. Move the saw carriage so the front end of the tool is positioned over the first bed rail. Measure from the bottom of the tool to the top surface of the bed rail.
3. Move the saw carriage so the rear of the tool is positioned over the bed rail. Again, measure from the bottom of the tool to the bed rail.
4. If the two measurements differ by more than 1/16" (1.5 mm), adjust the vertical tilt of the drive-side blade wheel.

See Figure 6-3. Use the vertical adjustment screws to adjust the drive-side blade wheel. To tilt the wheel down, loosen the top adjustment screw half turn. Loosen the jam nut on the bottom adjustment screw and tighten the screw. Tighten the top and bottom jam nuts.

To tilt the wheel up, loosen the bottom adjustment screw half turn. Loosen the jam nut on the top adjustment screw and tighten the screw. Tighten the top and bottom jam nuts.

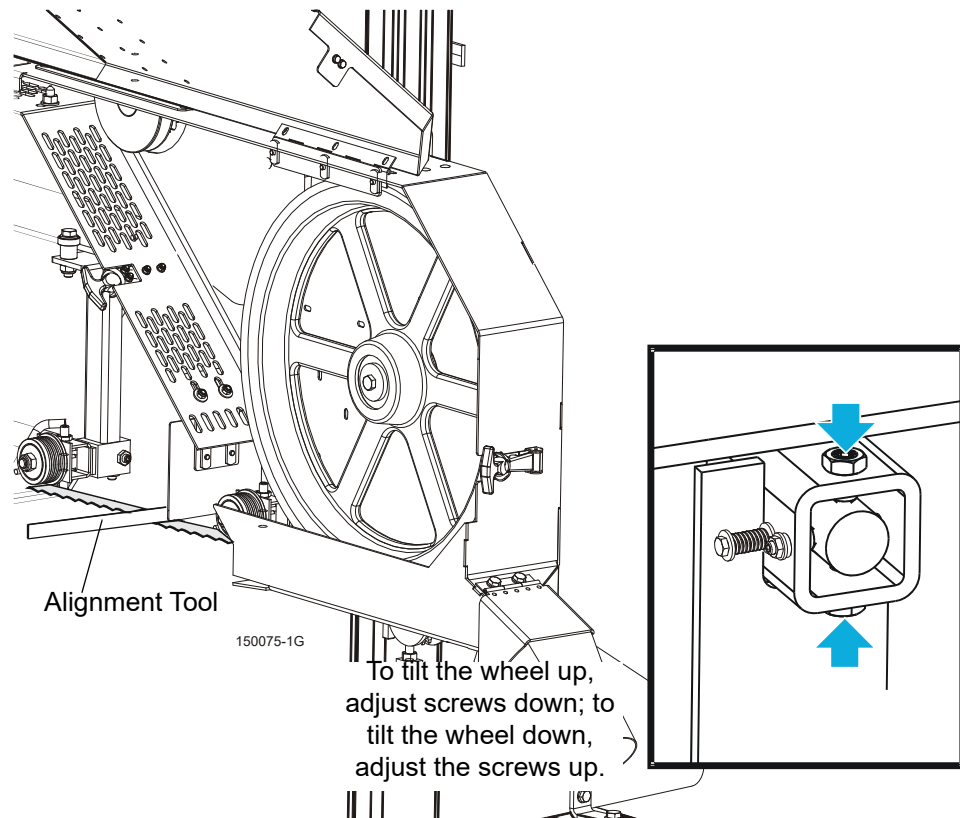

FIG. 6-3

5. Re-check the vertical tilt of the drive-side blade wheel with the blade guide alignment tool. Readjust the blade wheel as necessary until the front and rear of the tool are the same distance from the bed rail (within 1/16" [1.5 mm]).
6. Remove the tool from the blade and re-attach it near the outer blade guide assembly.
7. Measure from the tool to the bed rail at both ends of the tool. If the measurements at the front and rear ends of the tool differ by more than 1/16" (1.5 mm), adjust the vertical tilt of the idle-side blade wheel.

See Figure 6-4. Use the vertical adjustment screws to adjust the idle-side blade wheel. To tilt the wheel up, loosen the bottom nut and adjustment screw half turn. Loosen the jam nut on the top adjustment screw and tighten the screw. Tighten the top and bottom jam nuts.

To tilt the wheel down, loosen the top adjustment screw half turn. Loosen the jam nut on the bottom adjustment screw and tighten the screw. Tighten the top and bottom jam nuts.

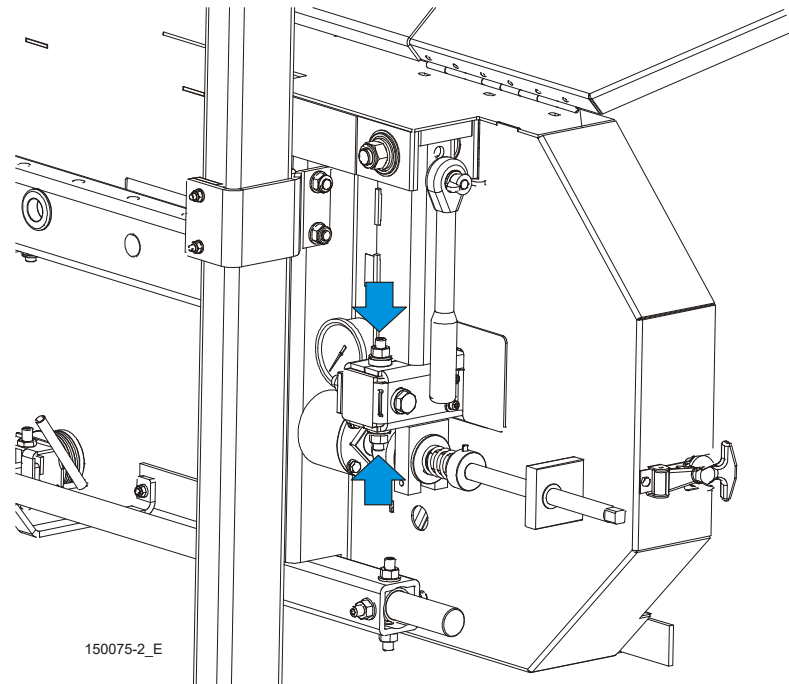

FIG. 6-4

8. Re-check the vertical tilt of the idle-side blade wheel. Readjust if necessary.
9. Check the position of the blade on the idle-side blade wheel.

See Figure 6-5. The horizontal tilt of the blade wheel should be adjusted so that the gullet of an 1-1/4" blade is 1/8" (3 mm) out from the front edge of the wheel ($\pm 1/32$ [0.75 mm]).

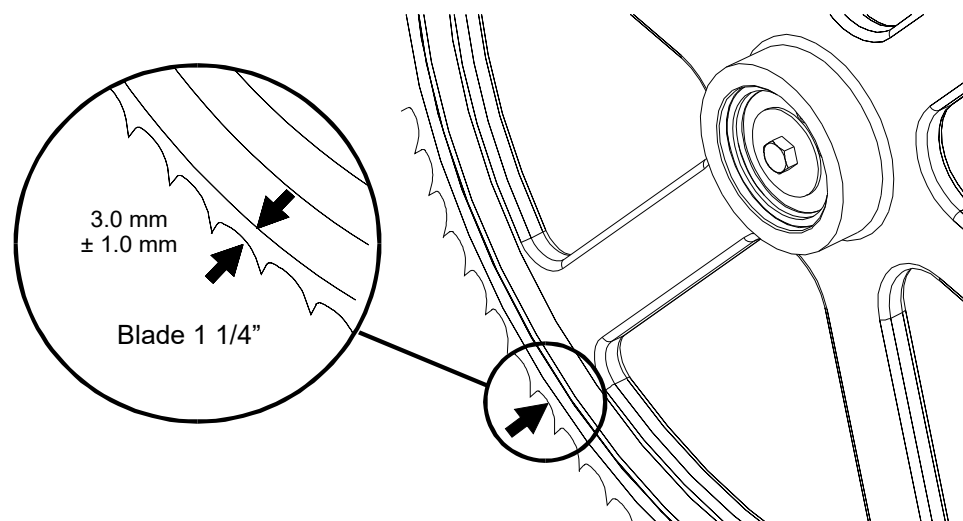

FIG. 6-5

See **Figure 6-6**. Use the cant control adjustment, shown on the figure below, to adjust the idle-side blade wheel. If the blade is too far forward on the wheel, turn the cant control counter clockwise. If it is too far back on the wheel, turn the cant control clockwise.

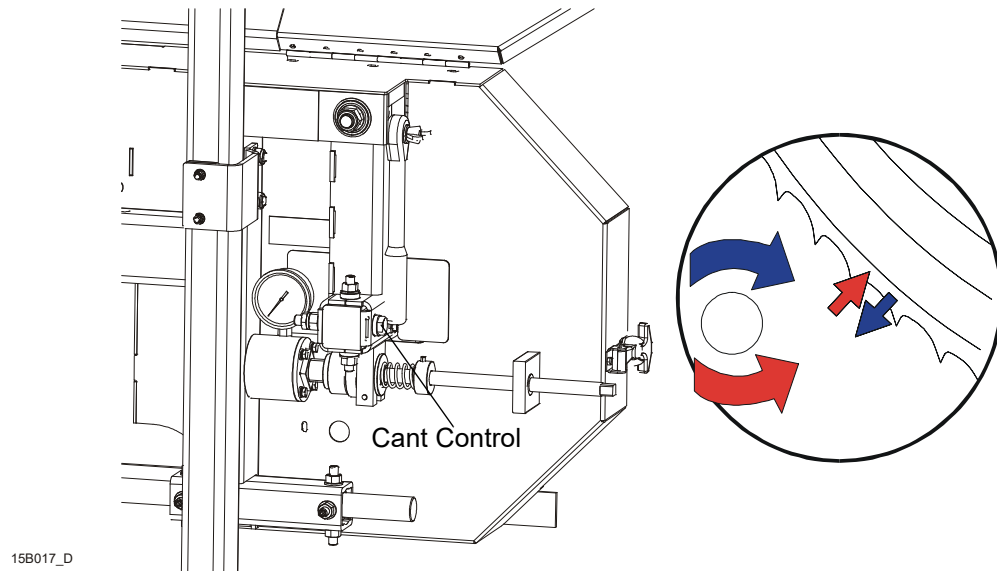

FIG. 6-6

10. Check the position of the blade on the drive-side blade wheel. The blade should be positioned on the wheel as described for the idle-side blade wheel. Adjust the drive-side blade wheel if necessary.

See **Figure 6-7**. Use the horizontal adjustment screw to adjust the drive-side blade wheel. Loosen the jam nut on the adjustment screw. Loosen adjustment screw to move blade out on wheel. Tighten

adjustment screw to move blade in on wheel. Tighten the jam nut.

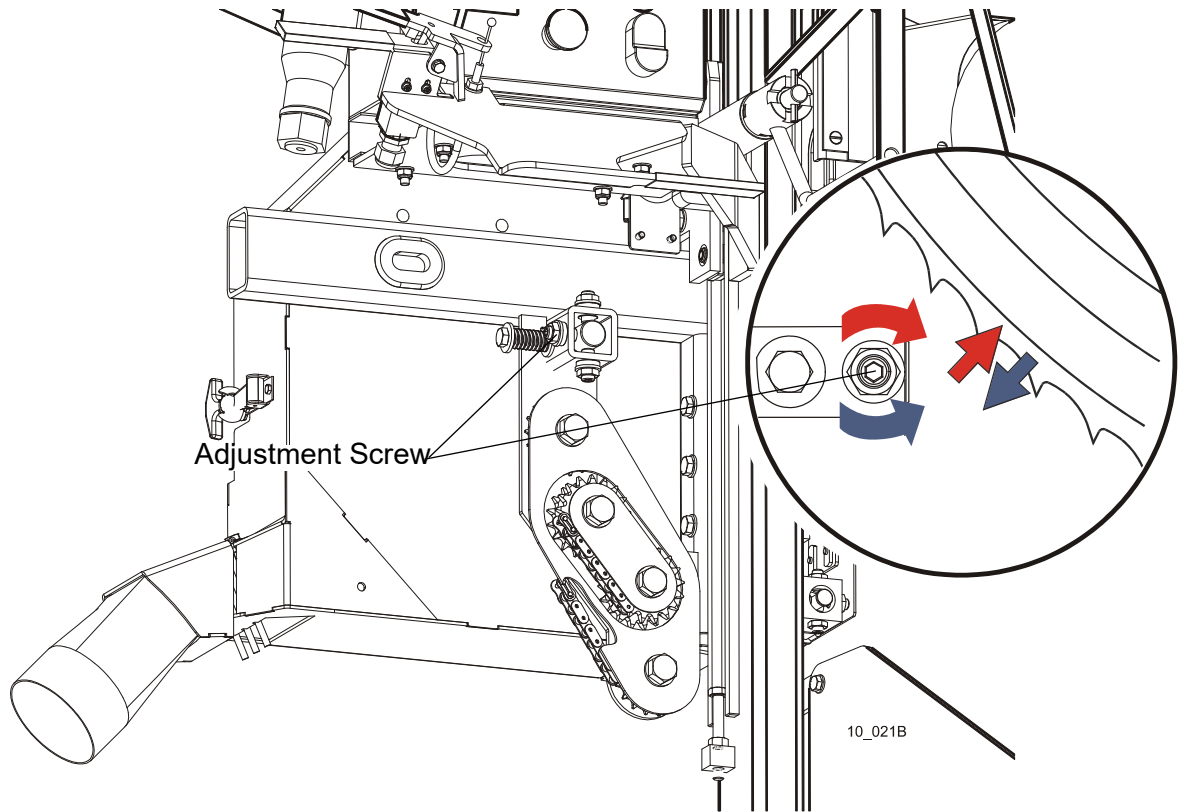

FIG. 6-7

11. Adjust the blade vibration damper screw. Distance from the screw to the blade should be about 1 mm.

See Figure 6-8.



FIG. 6-8

6.5 Blade Guide Arm Alignment

Before aligning the blade guide arm, track the blade on the blade wheels as described in [Section 3.4](#). Move the cutting head so the blade is positioned over the first bed rail. Level the blade to the bed rail as shown in [Section 3.1](#). Adjust the blade guide rollers so they do not touch the blade.

Vertical Alignment

1. Adjust the blade guide arm all the way out away from the other blade guide (maximum distance between the guide rollers).

See Figure 6-9.

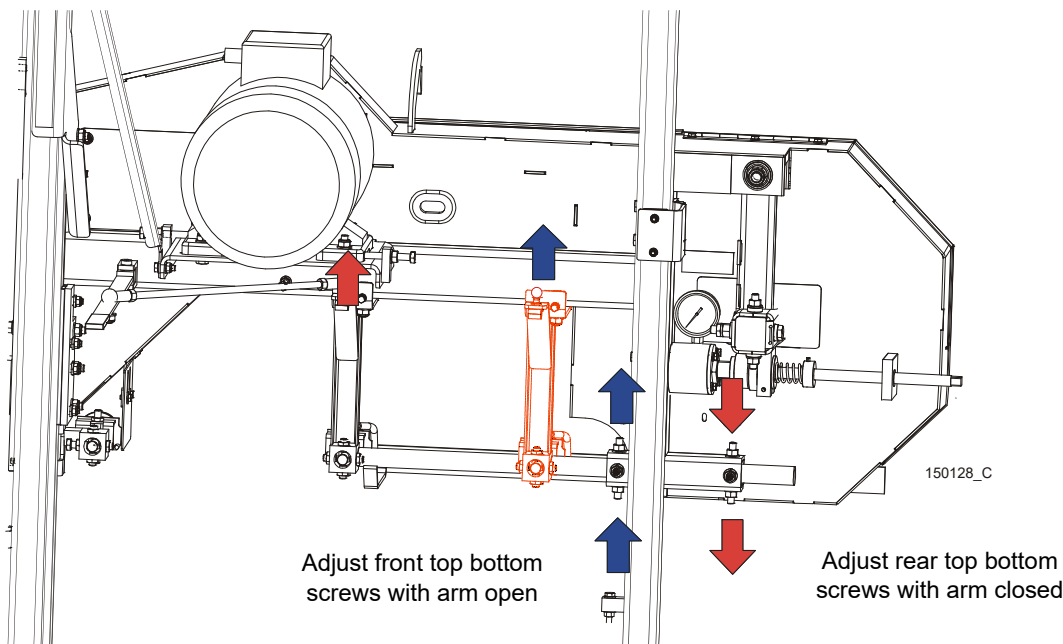

FIG. 6-9

2. Use the arm adjustment screws, marked with blue arrows in the figure above, to adjust the arm up until the slide pad touches the saw head brace tube. Tighten the jam nuts.
3. Adjust the blade guide arm in all the way toward the other blade guide (minimum distance between the guide rollers).
4. Use the arm adjustment screws, marked with red arrows in the figure above, to adjust the arm up until the slide pad touches the saw head brace tube. Tighten the jam nuts.

NOTE: When adjusting the blade guide arm screws, be careful not to damage their threads or deform the arm guide bushing. Operate the blade guide arm handle to ensure the arm moves easily left and right when the handle is moved.

Horizontal Alignment

See Figure 6-10.

1. With the blade guide arm still all the way in toward the other blade guide, tighten all the side screws until they touch the arm. Back the screws off 1/4 turn and tighten the jam nuts.
2. Sight across the horizontal saw head brace to view the blade guide arm. Adjust all side screws on the blade guide arm housing so the arm is parallel to the saw head brace.
3. To move the blade guide end of the arm toward the front of the sawmill, loosen jam nuts on the front inside screw and the rear outside screw. Turn the screws counterclockwise one full turn and tighten the jam nuts. Loosen the jam nuts on the front outside screw and the rear inside screw. Turn the screws clockwise until they touch the arm, back off 1/4" turn, and tighten the jam nuts.
4. To move the blade guide end of the arm toward the rear of the sawmill, loosen jam nuts on the front outside screw and the rear inside screw. Turn the screws counterclockwise one full turn and tighten the jam nuts. Loosen the jam nuts on the front inside screw and the rear outside screw. Turn the screws clockwise until they touch the arm, back off 1/4" turn, and tighten the jam nuts.

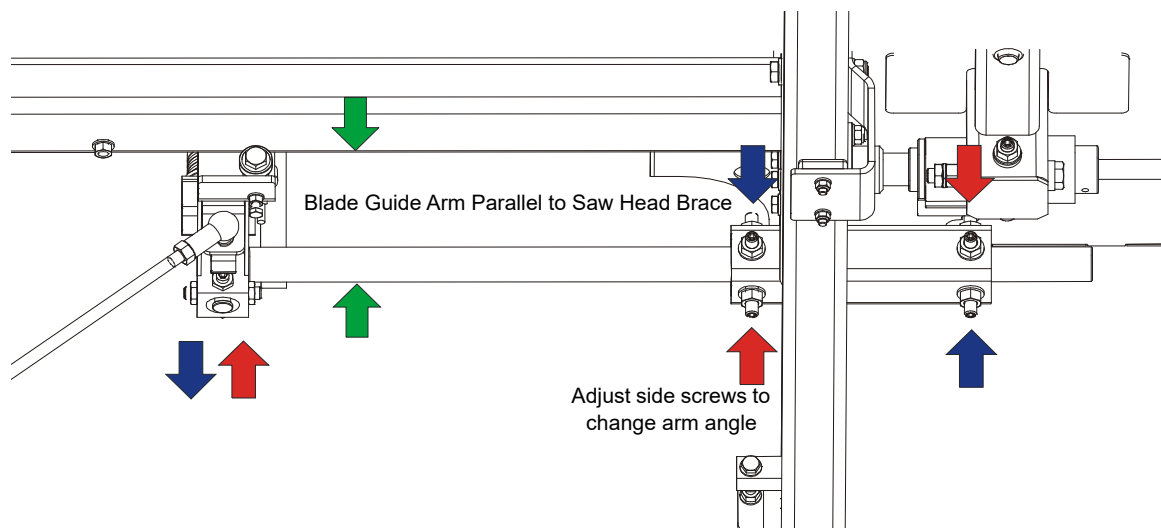

FIG. 6-10

6.6 Aligning The Blade Guides

Each Wood-Mizer sawmill has two blade guide assemblies that help the blade maintain a straight cut. The two blade guide assemblies are positioned on the saw head to guide the blade on each side of the material being cut.

One blade guide assembly is mounted in a stationary position on the drive side of the saw head. This assembly is referred to as the "inner" blade guide assembly.

The other blade guide assembly is mounted on the idle side of the saw head. It is referred to as the "outer" assembly and is adjustable for various widths of materials to be processed.

Blade guide alignment includes four steps:

- Blade Deflection,
- Blade Guide Vertical Tilt,
- Blade Guide Flange Spacing,
- Blade Guide Horizontal Tilt.

Perform the blade guide alignment after you have aligned the blade on the wheels and adjusted the blade and blade guide arm parallel to the bed rails. After blade guide alignment, check the scale indicator to make sure it is adjusted properly.

6.7 Blade Deflection

Perform the following steps to achieve proper blade deflection with the blade guides:

1. Raise the carriage until the blade is 15" (375 mm) above a bed rail. Measure the actual distance with a tape from the top of the rail to the bottom of the blade.

See Figure 6-11.

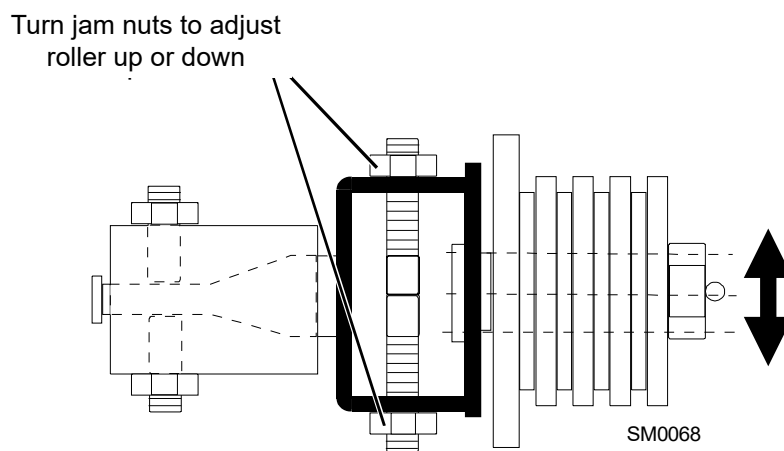

FIG. 6-11

2. Loosen the bottom jam nut and tighten the top jam nut until the blade guide deflects the blade down 1/4" (6 mm).
3. Repeat for the other blade guide.

NOTE: Be sure that the blade guard clears the blade on both guide assemblies. The guard on the outer guide assembly should be checked with the arm all the way in and all the way out.

6.8 Blade Guide Vertical Tilt Adjustment

Check that the blade guide does not tilt the blade up or down. A Blade Guide Alignment Tool (BGAT) is provided to help you measure the vertical tilt of the blade.

1. Open the adjustable blade guide arm 1/2" (15 mm) from full open.
2. Clamp the alignment tool on the blade. Position the tool close to a blade guide roller. Be sure the tool does not rest on a tooth or burr, and is lying flat on the blade.

See Figure 6-12.

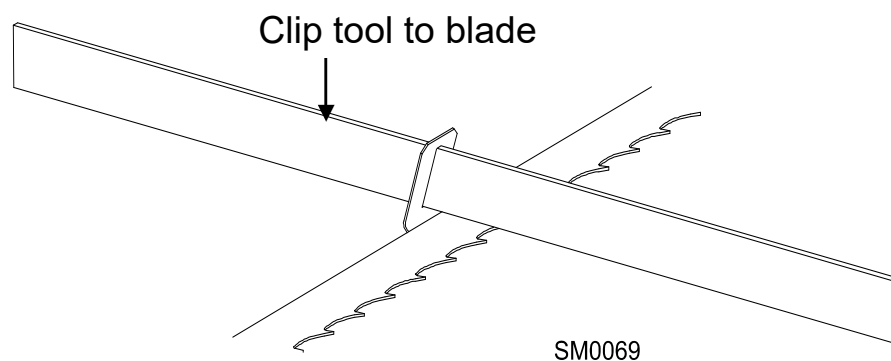

FIG. 6-12

3. Measure the distance from the bed rail to the bottom of the tool.
4. Move the carriage so that the front end of the tool is positioned above the bed rail.
5. Measure the distance from the bed rail to the bottom edge of the tool.
6. Use the set screws shown to tilt the blade guide until the measurement from the bed rail to the tool equals the first measurement taken at the center of the tool.

See Figure 6-13.

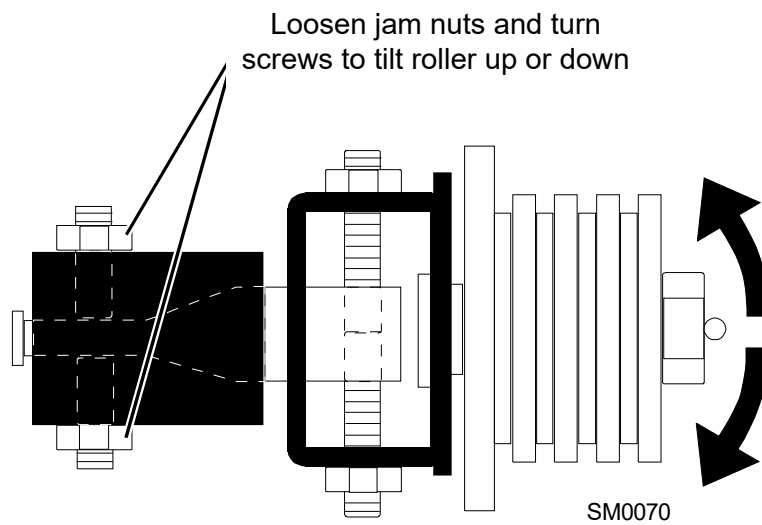

FIG. 6-13

7. Move the carriage forward so the back end of the tool is over the bed rail.
8. Use the set screws shown to adjust the blade guide tilt until the measurement from the bed rail to the tool equals the other two measurements taken.
9. Move the tool close to the other blade guide and repeat the previous steps.

NOTE: If major adjustments to blade guide tilt were made, remeasure the distance between the blade and the bed rails to ensure the correct 1/4" (6.5 mm) blade guide deflection. Adjust if necessary.

NOTE: After adjustment the blade guides, engage the blade for a moment and recheck blade guides adjustment.

6.9 Blade Guide Flange Spacing

HINT: When adjusting blade guide flange spacing, loosen the top set screw and one side set screw only. This will insure horizontal and vertical tilt adjustments are maintained when the set screws are retightened.

1. Adjust the inner blade guide so the blade guide flange is approximately 1/16" - 1/8" (1.5 - 3.0 mm) from the back of the blade.
2. Loosen one side and one top set screw shown on the figure below. Tap the blade guide forward or backward until properly positioned.

See Figure 6-14.

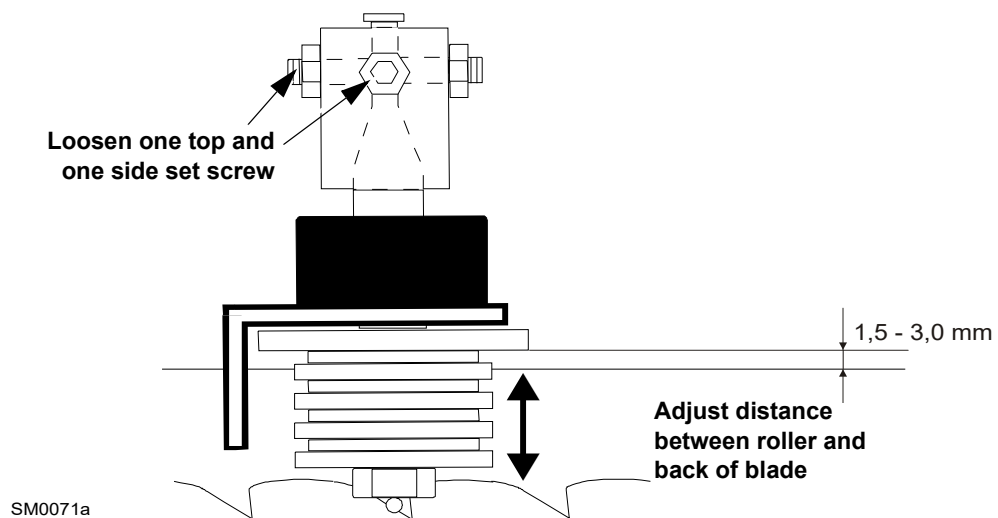

FIG. 6-14

3. Retighten the set screws.
4. Adjust the outer blade guide in the same way so the inner blade guide.

NOTE: After adjusting the spacing of the rollers, start the blade motor for a moment. Then stop the blade and check the spacing again.

6.10 Horizontal Tilt Adjustment

1. Move the blade guide arm half way in.

See Figure 6-15.

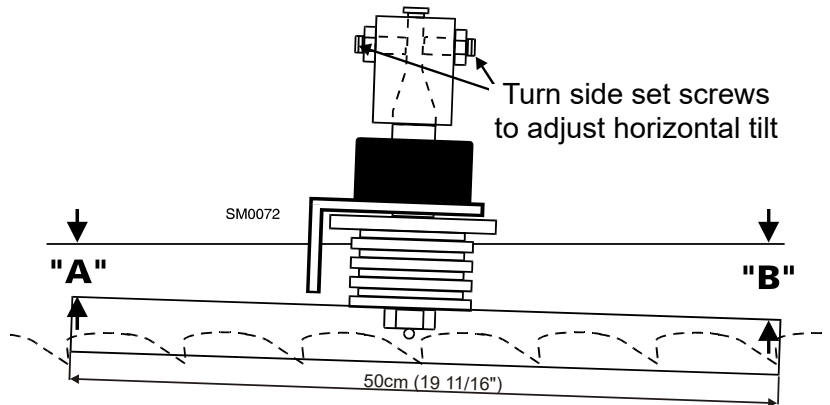

FIG. 6-15

2. Place Blade Guide Alignment Tool against the face of the outer blade guide roller, as shown above.
3. Measure between the back edge of the blade and the tool at the end closest to the inner blade guide ("B").
4. Measure between the back edge of the blade and the other end of the tool ("A").
5. The roller should be parallel to the blade ($A=B$) or tilted slightly to the left ($A=B-1/4"$ [6 mm]). Use the side set screws to adjust the horizontal tilt of the roller.
6. Repeat Steps 3 - 7 for the inner blade guide roller.

NOTE: Once the blade guides have been adjusted, any cutting variances are most likely caused by the blade. See **Blade Handbook, Form #600**.

6.11 Side Supports

Logs and boards are clamped against the side supports when sawing. The side supports must be square to the bed to ensure square lumber.

1. Place a flat board across the bed rails.

See Figure 6-16.

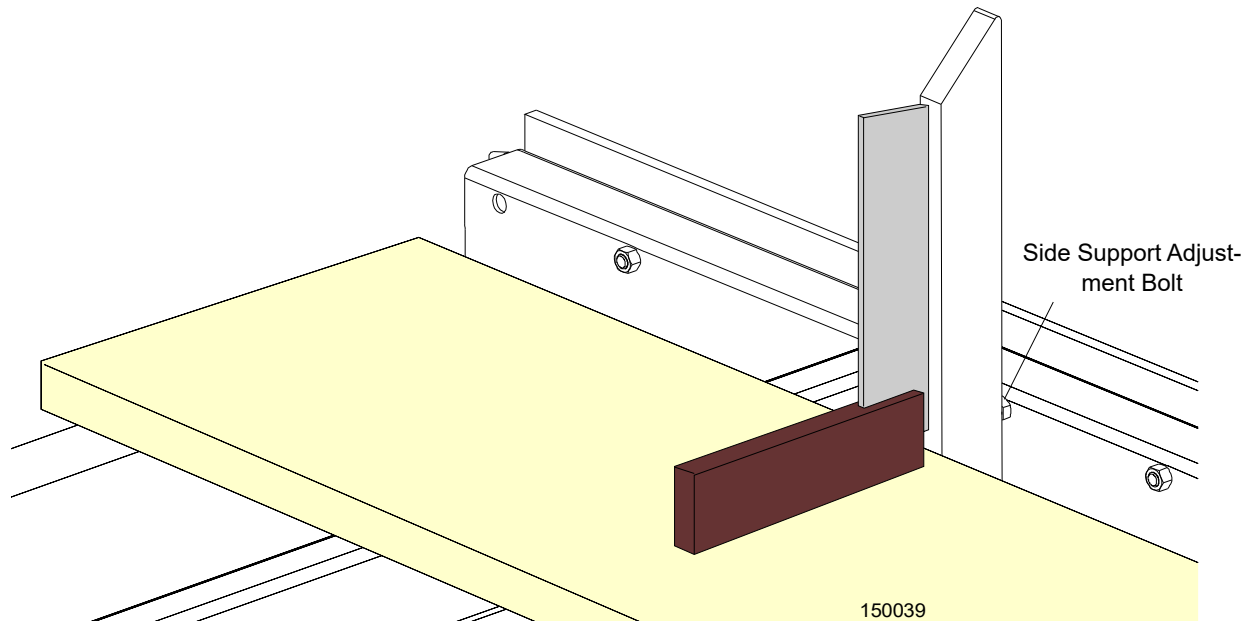

FIG. 6-16

2. Swing a side support up so that it is vertical.
3. Pull back at the top of the support to eliminate slack as if a log were being clamped against it.
4. Check the angle of each support with a square on the board.
5. The side support should be 90° to the bed rails. Turn the adjustment bolt counterclockwise to tilt the top of the side support forward.
6. Repeat for the remaining side supports.

6.12 Blade Height Scale Adjustment

Standard Scale

After the entire sawmill has been aligned and all adjustments made, check that the blade height scale indicates the true distance from the blade to the bed rails.

See Figure 6-17.

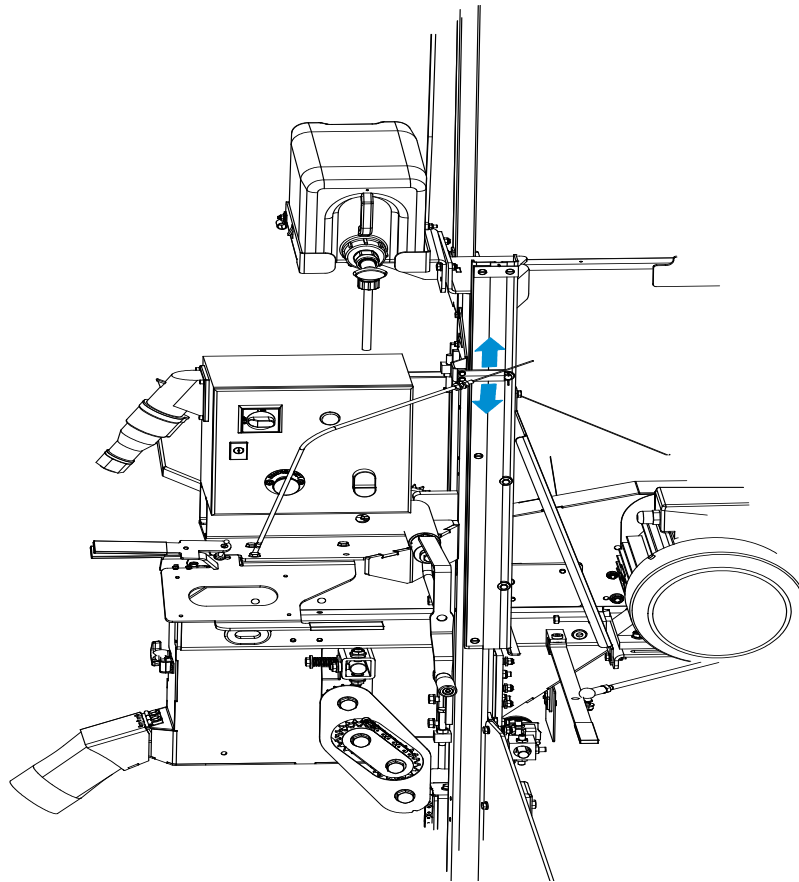

FIG. 6-17

1. Move the saw head so the blade is positioned directly above one of the bed rails. Measure from the bottom edge on a down-set tooth of the blade to the top of the bed rail.
2. Loosen the scale bracket mounting bolt and adjust the bracket until the indicator is aligned with the correct mark on the scale. Retighten the nut on the bracket mounting bolt.

Quarter Inch Scale (Option)

1. The maximum distance between the scale and the scale indicator should be 5 mm. If it is different, loosen the indicator bracket mounting bolts and move the bracket in the horizontal plane until the correct distance is obtained. Retighten the bracket mounting bolts.

See Figure 6-18.

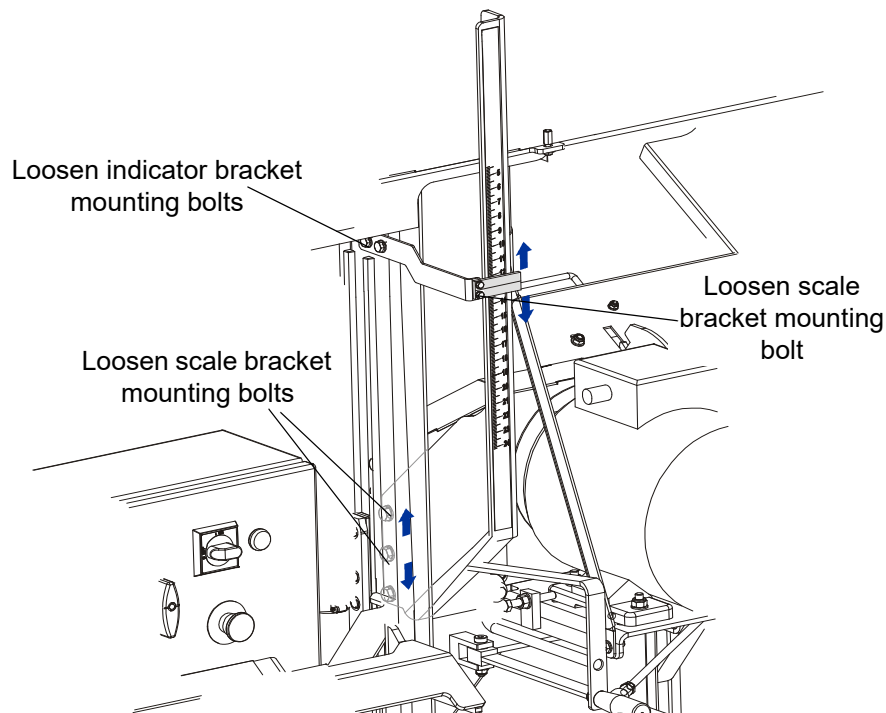

FIG. 6-18

2. Move the saw head so the blade is positioned directly above one of the bed rails. Measure from the bottom edge on a down-set tooth of the blade to the top of the bed rail.

Loosen the scale bracket mounting bolts and adjust the bracket until the indicator is aligned with the correct mark on the scale. Retighten the nuts on the bracket mounting bolts.

For example, if the measurement from blade to bed rail was 14 3/4" (375 mm), make sure the indicator reads 14 3/4" (375 mm) on the scale.

6.13 Motor Drive Belt Adjustment

See Figure 6-19. Loosen the motor mounting bolts. Using the adjustment bolts shown below, adjust the drive belt until it has 7/16" (11 mm) deflection with a 8 lbs (3.6 kG) deflection force - in the case of E11 motor or 7/16" (11 mm) deflection with a 16 lbs (7.2 kG) deflection force - in the case of E15

motor. Tighten the four motor mounting bolts.

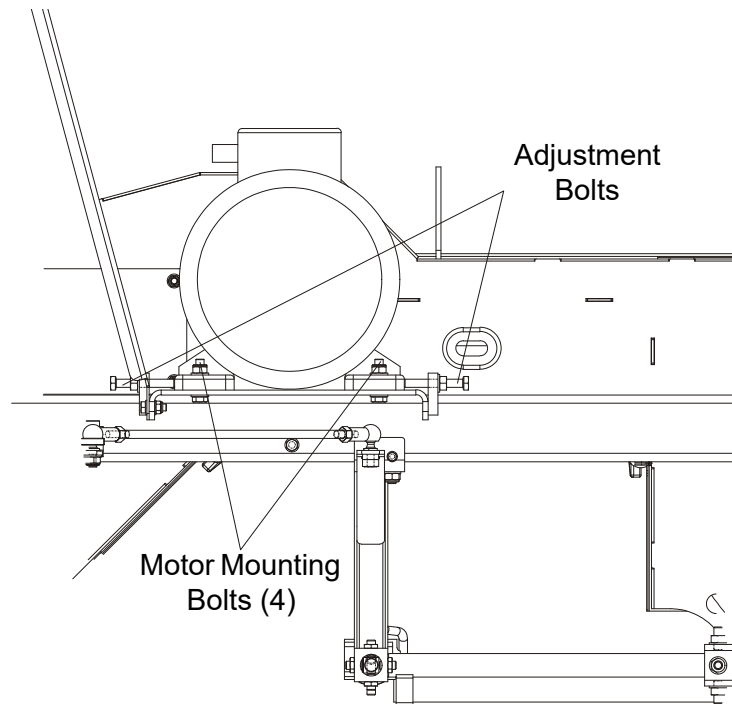

FIG. 6-19

6.14 Safety Handle Linkage Adjustment

See Figure 6-20. Use the adjustment nuts to adjust linkage tension so the blade stops during

8 seconds after the safety handle is released.

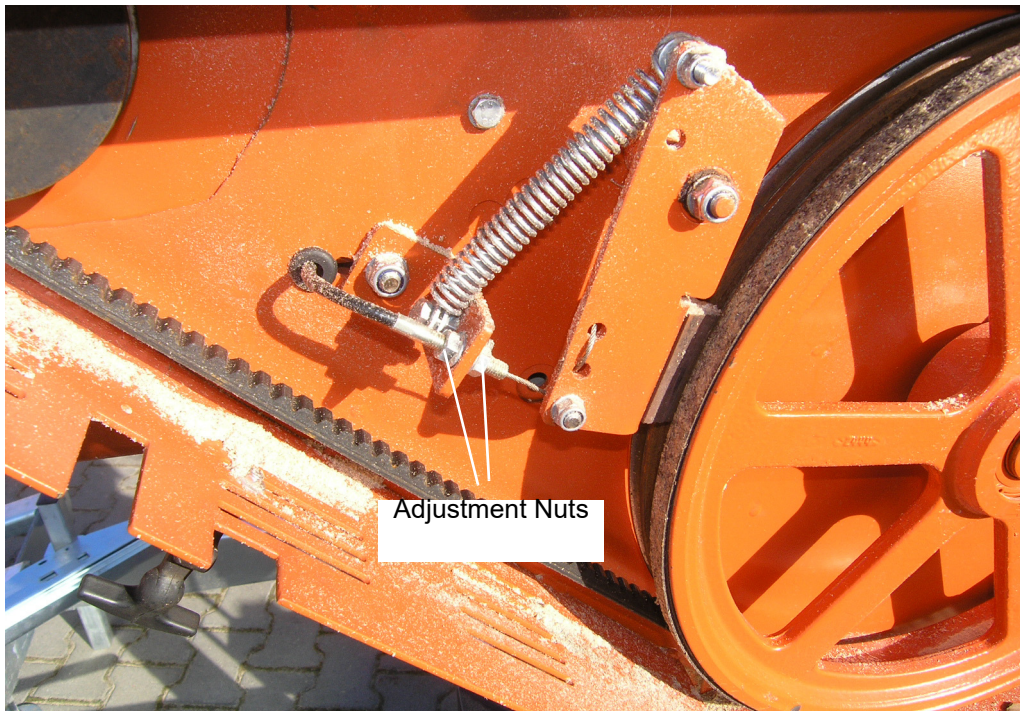

FIG. 6-20

6.15 Track Roller Distance Adjustment

Using the screw (1), adjust the distance between the track roller (2) and the track rail (3) so that the vertical mast can move freely (see the figure below). The distance should be about 0.5 mm.

See Figure 6-21.

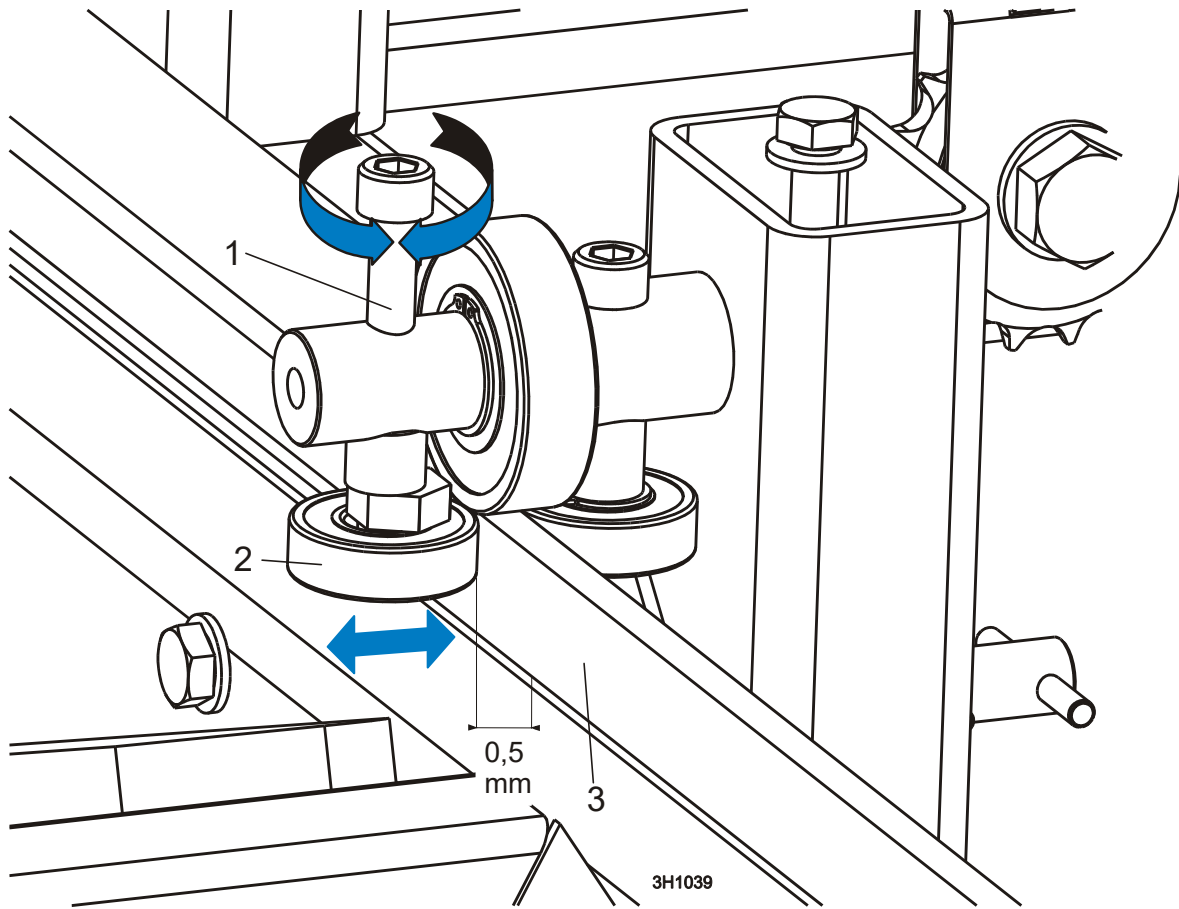

FIG. 6-21

SECTION 7 MOTOR BRAKE

7.1 Motor Brake Maintenance

Maintenance intervals

Service brakes	<ul style="list-style-type: none"> ■ after 4000 hours of operation at the latest or every six months
-----------------------	---

TABLE 7-1.



IMPORTANT! Brakes with defective armature plates, cheese head screws, springs or flanges must be replaced completely.

Please observe the following for inspections and maintenance operations:

- Remove impurities through oil and grease using brake cleaning agents, if necessary, replace brake after finding out the cause of the contamination. Dirt deposits in the air gap between stator and armature plate impair the function of the brake and must be removed.
- After replacing the rotor, the original braking torque will not be reached until the run-in operation of the friction surfaces has been completed. After replacing the rotor, run-in armature plates and flanges have an increased initial rate of wear.

Checking the rotor thickness



DANGER! The motor must not be running when checking the rotor thickness.

- Remove the motor cover and seal ring (if mounted).
- Measure the rotor thickness with a caliper gauge. On brakes with friction plates, observe edging on outer diameter of friction plate.
- Compare measured rotor thickness with minimally permissible rotor thickness. [See Table 7-2.](#)
- Replace the complete rotor if necessary.

Check the air gap

- Measure the air gap "sL_ü" between armature plate and rotor using a feeler gauge (see chapter 3.3).
- Compare the measured air gap to the maximum permissible air gap "sL_{ümax}." (see table below).

- If necessary, adjust the air gap to "sLürated".

Brake type	sLürated +0.1mm -0.05mm	sLümax Service brake	Max. adjustment permissible wear	Rotor thickness		Excess of the adjuster nut h _E max. [mm]
				min. ¹⁾ [mm]	max. [mm]	
INTORQ BFK458-25	0,4 mm (1/64")	1,0 mm (3/64")	4,0 mm (5/32")	12 mm (15/32")	16 mm (5/8")	17 mm (43/64")

TABLE 7-2.

EC declaration of conformity

according to EC Machinery Directive 2006/42/EC, Annex II, 1.A

Manufacturer:

Wood-Mizer Industries sp. z o.o.
Nagórna 114, 62-600 Koło; Poland
Tel. +48 63 26 26 000

This declaration of conformity is issued under the sole responsibility of the manufacturer.

Following machine in our delivered version complies with the appropriate essential safety and health requirements of the EC Machinery Directive 2006/42/EC based on its design and type, as brought into circulation by us. In case of alteration of the machine, not agreed by us, this declaration is no longer valid.

We, the undersigned herewith declare, that:

Designation of the machine: **SAWMILL**

Model: LT15

TYPE:

Serial Number:

VIN Number:

Is in conformity with the following EC directives:

EC Machinery Directive 2006/42/EC
EC Electromagnetic Compatibility Directive
2014/30/EU

And is in conformity with the following Harmonized Standards:

PN-EN 1807-2:2013-08
PN-EN ISO 13849-1:2016-02
PN-EN 60204-1:2018-12

Notified Body according to annex IV: Sieć Badawcza Łukasiewicz
INSTYTUT TECHNOLOGII DREWNA
Centrum Weryfikacji Wyrobów Przemysłu Drzewnego
ul. Winiarska 1, 60-654 Poznań

Notification No.: 1583

EC type-examination certificate no. 0719/2019

Responsible for Technical Documentation: Piotr Adamiec / Engineering Manager
Wood-Mizer Industries Sp. z o.o.
62-600 Koło, Nagórna 114, Poland
Tel. +48 63 26 26 000

Place/Date/Authorized Signature: Koło, 19.09.2019 

Title: Engineering Manager