

INDUSTRIAL PRODUCTS

Parts Manual



MultiHead Resaw

Rev. A2.00



Safety is our #1 concern! Read and understand all safety information and instructions before operating, setting up or maintaining this machine.

Form #739

Table of Contents

Section-Page

SECTION 1	GENERAL INFORMATION	1-1
1.1	How To Use The Parts List	1-1
1.2	Sample Assembly	1-1
SECTION 2	SAW HEAD PARTS	2-1
2.1	Blade Tensioner Assembly	2-1
2.2	Tension Release Handle Assembly	2-3
2.3	Saw Head Mount Assembly	2-5
2.4	Saw Motor Assembly	2-6
2.5	Inner Blade Guide Assembly (1" Blade)	2-8
2.6	Outer Blade Guide Assembly (1" Blade)	2-10
2.7	Up/Down Assembly	2-12
2.8	Blade Wheel Assembly (Drive Side)	2-14
2.9	Blade Wheel Assembly (Idle Side)	2-16
2.10	Blade Housing Cover	2-18
2.11	Safety decals, Multihead	2-19
SECTION 3	FEED TRACK/FRAME PARTS	3-1
3.1	Hydraulic Blade Tensioner Assembly	3-1
3.2	Perimeter Fence Assembly	3-2
3.3	Feed Track Assembly	3-4
3.4	Feed Track Nylon Pads	3-6
3.5	Feed Roller Assembly (Non-Air)	3-7
3.6	Feed Roller Assembly (Air-Lift)	3-9
3.7	Hydraulic Tank Assembly	3-11
3.8	Hydraulic Valve Assembly (2 and 4-Head)	3-13
3.9	Hydraulic Valve Assembly (6-Head)	3-14
3.10	Crowder Fence Assembly	3-15
	INDEX	1-I

SECTION 1 GENERAL INFORMATION

1.1 How To Use The Parts List

- Use the table of contents or index to locate the assembly that contains the part you need.
- Go to the appropriate section and locate the part in the illustration.
- Use the number pointing to the part to locate the correct part number and description in the table.
- Parts shown indented under another part are included with that part.
- Parts marked with a diamond (◆) are only available in the assembly listed above the part.

See the sample table below. Sample Part #A01111 includes part F02222-2 and subassembly A03333. Subassembly A03333 includes part S04444-4 and subassembly K05555. The diamond (◆) indicates that S04444-4 is not available except in subassembly A03333. Subassembly K05555 includes parts M06666 and F07777-77. The diamond (◆) indicates M06666 is not available except in subassembly K05555.

1.2 Sample Assembly				
REF	DESCRIPTION (◆ Indicates Parts Available In Assemblies Only)	PART #	QTY.	
	SAMPLE ASSEMBLY, COMPLETE (INCLUDES ALL INDENTED PARTS BELOW)	A01111	1	
1	Sample Part	F02222-22	1	
	Sample Subassembly (Includes All Indented Parts Below)	A03333	1	
2	Sample Part (◆ Indicates Part Is Only Available With A03333)	S04444-4	1	◆
	Sample Subassembly (Includes All Indented Parts Below)	K05555	1	
3	Sample Part (◆ Indicates Part Is Only Available With K05555)	M06666	2	◆
4	Sample Part	F07777-77	1	

To Order Parts:

- From the continental U.S., call **1-800-448-7881** to order parts. Have your customer number, serial number, and part numbers ready when you call.
- From other international locations, contact the Wood-Mizer distributor in your area for parts.

SECTION 2 SAW HEAD PARTS

2.1 Blade Tensioner Assembly

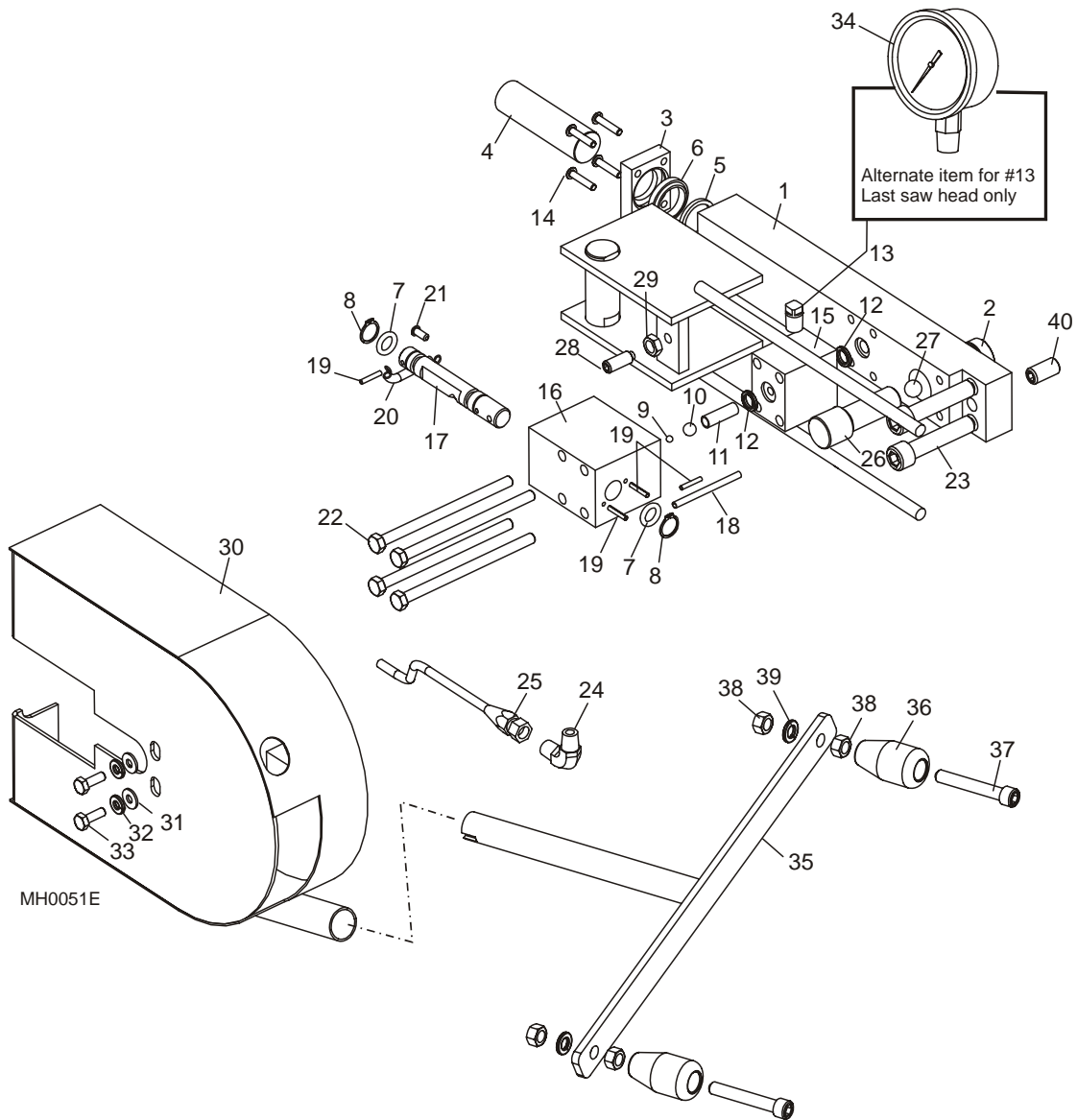

REF	DESCRIPTION (◆ Indicates Parts Available In Assemblies Only)	PART #	QTY. (*/head)
	TENSIONER ASSEMBLY, MULTIHEAD BLADE	A22220	1*
1	Bar, Blade Tensioner	022221	1
2	Bushing, 3/4-32 Threaded	S22786	1
3	Block, Tensioner Seal	S10089-W	1

4	Piston, Blade Tensioner	S10059-W	1	
	Rebuild Kit, Hydraulic Tensioner	A22910	1	
5	Seal, 1" Diameter Tensioner	P10051	1	
6	Wiper, 1" Diameter Tensioner	P10053	1	
7	O-Ring, Tensioner Valve Spool	P09685	2	
8	Ring, 5/8" Retainer	F04254-2	2	
9	Ball, 3/16" Diameter Steel	P09744	1	
10	Ball, 3/8" Diameter Steel	P09133	1	
11	Spring, LC-038E-15SS	P22041	1	
12	O-Ring, 5/8" x 3/32" Square	P10377	2	
13	Plug, 1/4" NPT Pipe	P05498	1	
14	Bolt, #10-24 Socket Button Head	F05004-43	4	
15	Block, Tensioner Valve Mount	S22213	1	
16	Block, Tensioner Valve	S22216	1	
17	Spool, Tensioner Valve	S22326	1	
18	Pin, 3/16" x 2 1/2" Roll	F05012-27	1	
19	Pin, 1/8" x 3/4" Roll	F05012-6	4	
20	Spring, LE-041C-7MW	P10064	1	
21	Screw, #7 x 1/2" Drive	F05015-25	1	
22	Bolt, 5/16-18 x 5" Hex Head Grade 8	F05006-52	4	
23	BOLT, 1/2-20 X 1 1/2" SOCKET HEAD	F05008-44	2	
24	FITTING, 1/4" NPT 90° ELBOW	P09140	1*	
25	HOSE, 1/4" DIA. X 78" HYDRAULIC W/FITTINGS	P22299	1*	
	HANDLE ASSEMBLY, IDLE WHEEL TILT	A11309	1*	
26	Screw, Cant Adjustment	S11058	1	
27	Ball, 1/2" Dia. Detent	P02720	1	
	DECAL, DANGER MOVING PARTS	S10692	1	◆
28	SCREW, 3/8-16 X 1" SOCKET HEAD BRASS TIP	F05007-88	1*	
29	NUT, 3/8-16 HEX JAM	F05010-29	1*	
30	COVER, MULTIHEAD IDLE HUB	W22469	1	
31	WASHER, 1/4" FLAT SAE	F05011-11	2*	
32	WASHER, 1/4" SPLIT LOCK	F05011-14	2*	
33	BOLT, 1/4-20 X 3/4" HEX HEAD	F05005-1	2*	
34	GAUGE, 3000 P.S.I BLADE TENSION	P10052	1	
	CRANK HANDLE ASSEMBLY	033251	1	
35	Crank Weldment, Toe Board Painted	033253	1	
36	Handle, Power Feed & Up/Down	S08291-W	2	
37	Screw, 3.8-16 x 2 1/2" Socket Head Cap	F05007-24	2	
38	Nut, 3/8-16 Free Hex	F05010-1	4	
39	Washer, 3/8" Split Lock	F05011-4	2	
40	SCREW, 1/2-13 X 1" OVAL POINT SET NYLON LOCK	F05008-9	1	

2 Saw Head Parts

Tension Release Handle Assembly

2.2 Tension Release Handle Assembly

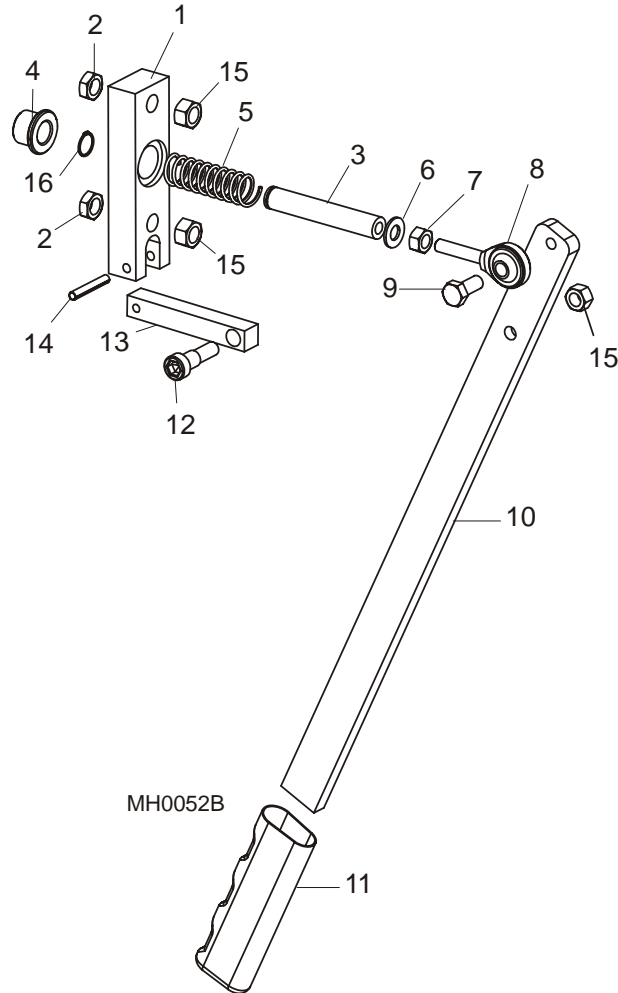

REF	DESCRIPTION (◆ Indicates Parts Available In Assemblies Only)	PART #	QTY.	
	HANDLE ASSEMBLY, TENSION RELEASE	A22528	1*	
1	Plate, Tensioner Stop	S22527	1	
2	Nut, 3/8-16 Hex Jam	F05010-29	2	
3	Rod, Tensioner Push	S22526	1	
4	Bushing, Flanged Bronze	P22662	1	
5	Spring, LC-072J-7MW	P05155	1	
6	Washer, 5/16" SAE Flat	F05011-17	1	
7	Nut, 5/16-24 Hex	F05010-28	1	
8	Rod End, 5/16-24 Male	P09814	1	
9	Bolt, 5/16-18 x 3/4" Hex Head	F05006-5	1	
10	Handle, Tension Release	S22524	1	
11	Grip, Tension Release Handle	P04731	1	
12	Bolt, 3/8" x 1/2" Shoulder	F05006-56	1	

Saw Head Parts*Tension Release Handle Assembly***2**

13	Bar, Tension Release Handle Link	S22525	1	
14	Pin, 3/16" x 1 1/4" Roll	F05012-16	1	
15	Nut, 3/8-16 Hex Lock	F05010-25	2	
16	Ring, 1/2" Retainer	F04254-18	1	
17	Nut, 5/16-18 Hex Lock	F05010-6	1	

2

Saw Head Parts

Saw Head Mount Assembly

2.3 Saw Head Mount Assembly

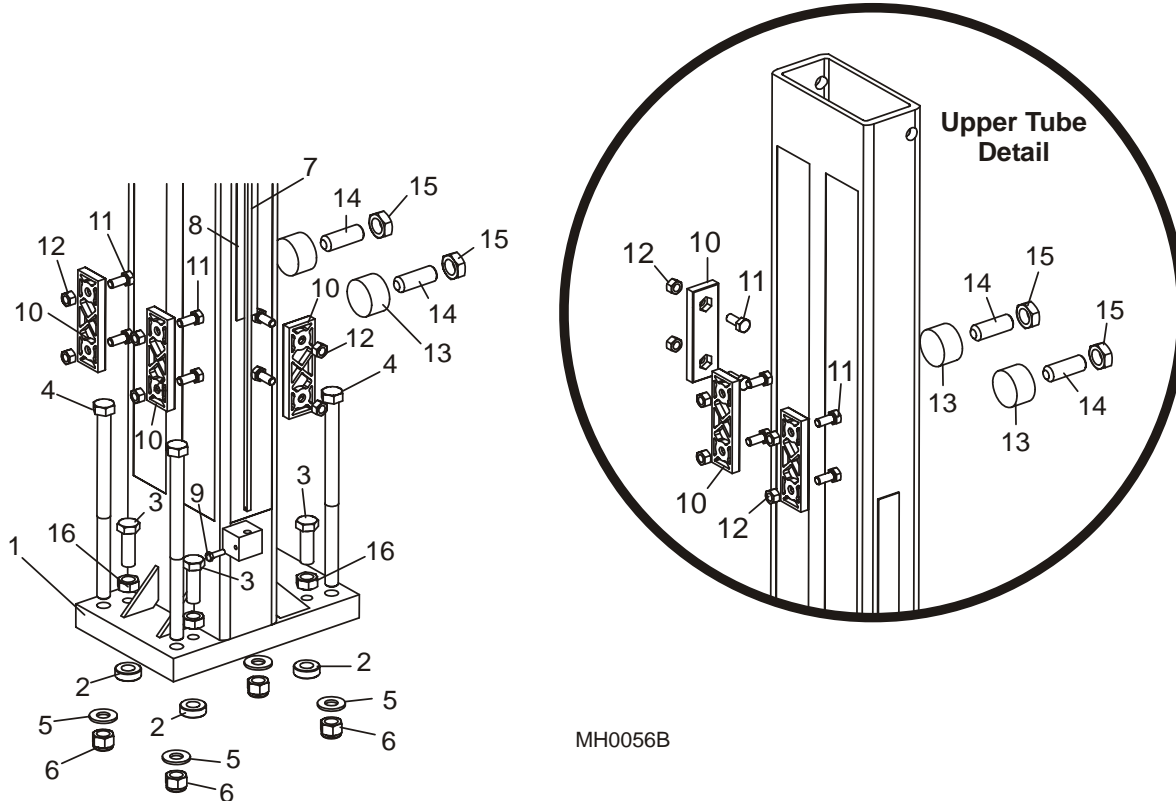

MH0056B

REF	DESCRIPTION (◆ Indicates Parts Available In Assemblies Only)	PART #	QTY. (* /head)
1	TUBE WELDMENT, SAWHEAD MOUNT	W22549	1
2	PAD, STEEL SAW MOUNT	S22563	2
3	BOLT, 1/2-13 X 1 1/2" HEX HEAD GRADE 5	F05008-33	4
4	BOLT, 1/2-13 X 8" HEX HEAD GRADE 5	F05008-69	4
5	WASHER, 1/2" SAE FLAT	F05011-2	4
6	NUT, 1/2-13 NYLON LOCK	F05010-8	4
7	POINTER, MULTIHEAD BLADE HEIGHT	S22636	1
8	DECAL, MULTIHEAD HEIGHT SCALE (INCH)	S22300	1
	DECAL, MULTIHEAD HEIGHT SCALE (METRIC)	S22301	1
9	BOLT, #10-24 X 5/8" HEX HEAD	F05004-18	1
10	PAD, UP/DOWN DELRIN	M04096	6
11	BOLT, 5/16-18 X 3/4" HEX HEAD	F05006-5	12
12	NUT, 5/16-18 HEX LOCK	F05010-6	12
13	PAD, UP/DOWN ADJUSTABLE NYLON	S22561	4
14	SCREW, 5/8-18 X 1 1/4" SOCKET HEAD FLAT POINT SET	F05009-27	4
15	NUT, 5/8-18 HEX JAM	F05010-11	4
16	NUT, 1/2-13 HEX	F05010-35	4

2.4 Saw Motor Assembly

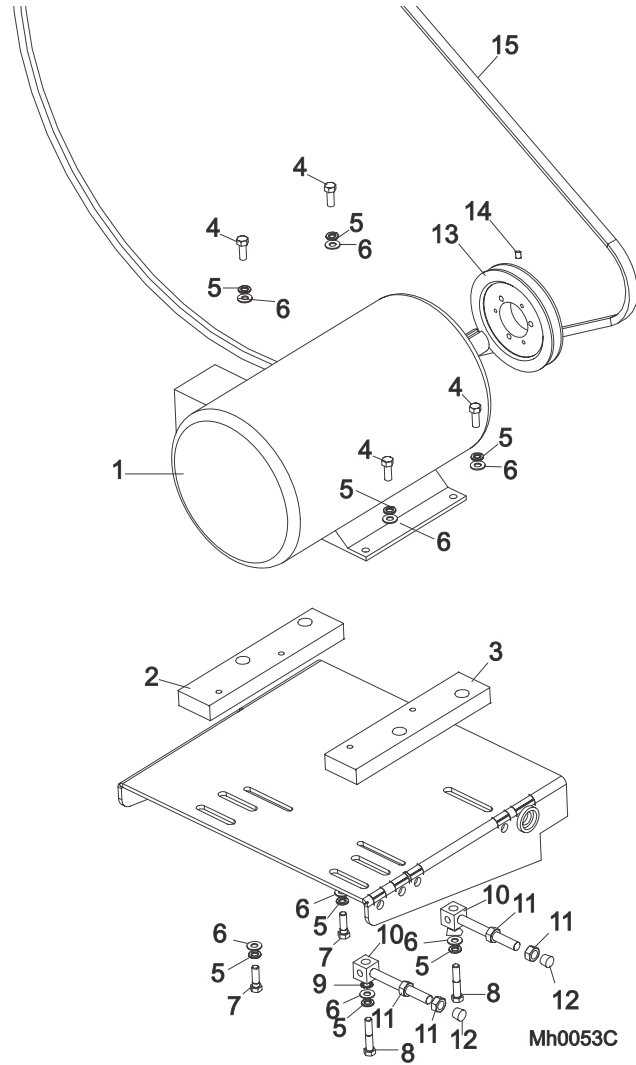

REF	DESCRIPTION (◆ Indicates Parts Available In Assemblies Only)	PART #	QTY. (* /head)	
1	MOTOR ASSEMBLY			
	Motor, 15kW Sg160M2B-HM	087929	1*	◆
	Motor, 11kW Sg132S -2PC HM	089049	1*	
2	Bar, Motor Mount Spacer Left	094506-1	1	
3	Bar, Motor Mount Spacer Right	094651-1	1	
4	Bolt, M10x140-4.8-Fe/Zn5	F81003-14	4	
5	Washer, 10.2 Fe/Zn5 Split Lock	F81055-2	8	
6	Washer, 10,5 Fe/Zn5 SAE Flat	F81055-6	8	
7	Bolt, 3/8-16 x 1 1/4" Hex Head	F05007-2	2	
8	Bolt, 3/8-16 x 2" Hex Head	F05007-72	2	

2**Saw Head Parts***Saw Motor Assembly*

	Instruction Sheet, MultiHead Motor Mount Spacer Retro	A22325-386	1	
9	WASHER, 3/8" EXTERNAL STAR LOCK	F05011-36	2*	
10	BLOCK, MOTOR TENSION	W22086	2*	
11	NUT, 1/2-13 HEX	F05010-35	4*	
12	CAP, 1/2" PLASTIC END	P22320	2*	
13	PULLEY, E15 MULTIHEAD	094505	1*	
	PULLEY, E20 MULTIHEAD	094330	1*	
14	SCREW, SET,M8x8-33H FE/ZN HEX SCKT HEAD	F81014-1	1*	
15	BELT, 5VX1230 DRIVE V	033302	1*	

2.5 Inner Blade Guide Assembly (1" Blade)

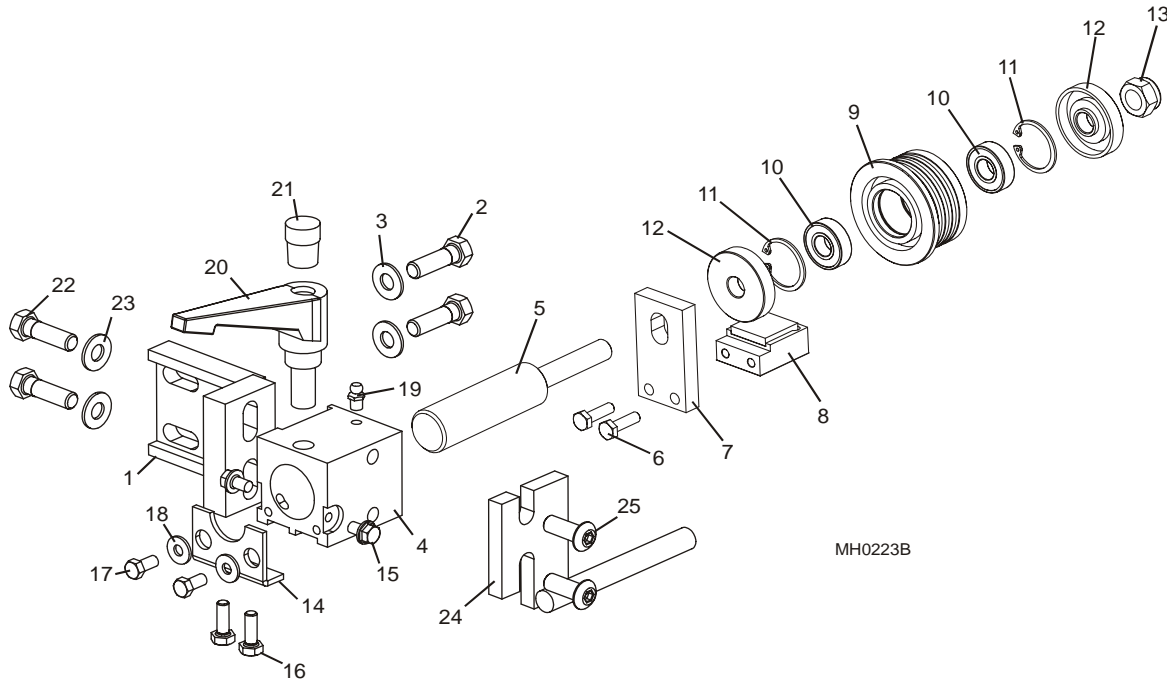

REF	DESCRIPTION (◆ Indicates Parts Available In Assemblies Only)	PART #	QTY. (*head)	
1	BRACKET, INNER BLADE GUIDE MOUNTING	W22690	1*	
2	BOLT, 3/8-24 X 1 1/4" HEX HEAD GRADE 5	F05007-102	2	
3	WASHER, 3/8" SAE FLAT	F05011-3	2	
	GUIDE ASSEMBLY, TRIPLE-BLOCK INNER 1" BLADE	035260	1*	
4	Block, Blade Guide Mounting (Inner)	S22581	1	
	Guide Assembly w/Roller	095957	1	
5	Shaft, Blade Guide Zinc	095080-1	1	
6	Bolt, M6X20mm, HH, Full Thread, Zinc	F81001-2	2	
7	Plate, Blade Guide Mount Back	095958-1	1	
8	Block, Blade Guide Complete	096954-1	1	
9	Roller, Blade Guide Narrow W/Bearings	088261	2	
10	Bearing, 6001 2RSR NACHI	087893	2	
11	Ring, W28 Inside Retaining	F81090-9	2	
12	Washer, Spacer	087891-1	2	
13	Nut, M12-8 Hex Nylon Zinc Lock	F81034-2	1	
	Upgrade Kit, Blade Guide Rear Alignment Plate	A22420	1	
14	Plate, Rear Blade Guide Alignment	S22584	1	◆
15	Screw, 1/4-20 x 3/8" Flanged	F05005-78	2	
16	Bolt, 1/4-20 x 3/4" Hex Head	F05005-1	2	

2

Saw Head Parts

Inner Blade Guide Assembly (1" Blade)

17	Bolt, 1/4-20 x 1/2" Hex Head	F05005-15	2	
18	Washer, 1/4" Flat	F05011-11	2	
	Instruction Sheet, Upgrade Kit, Blade Guide Rear Alignment	A22420-256	1	◆
19	Fitting, 1/4-28 Grease	P05060	1	
20	Handle, Blade Guide Adjustment	P22595	1	
21	Cap, Blade Guide Adjustment Handle	P22668	1	
22	Bolt, 3/8-24 x 1 1/4" Hex Head Grade 5	F05007-102	2	
23	Washer, 3/8" SAE Flat	F05011-3	2	
24	PLATE WELDMENT, INNER BLADE DEFLECTOR	W22408	1*	
25	Screw, 3/8-24 x 1" Button Head Cap	F05007-80	2	

2.6 Outer Blade Guide Assembly (1" Blade)

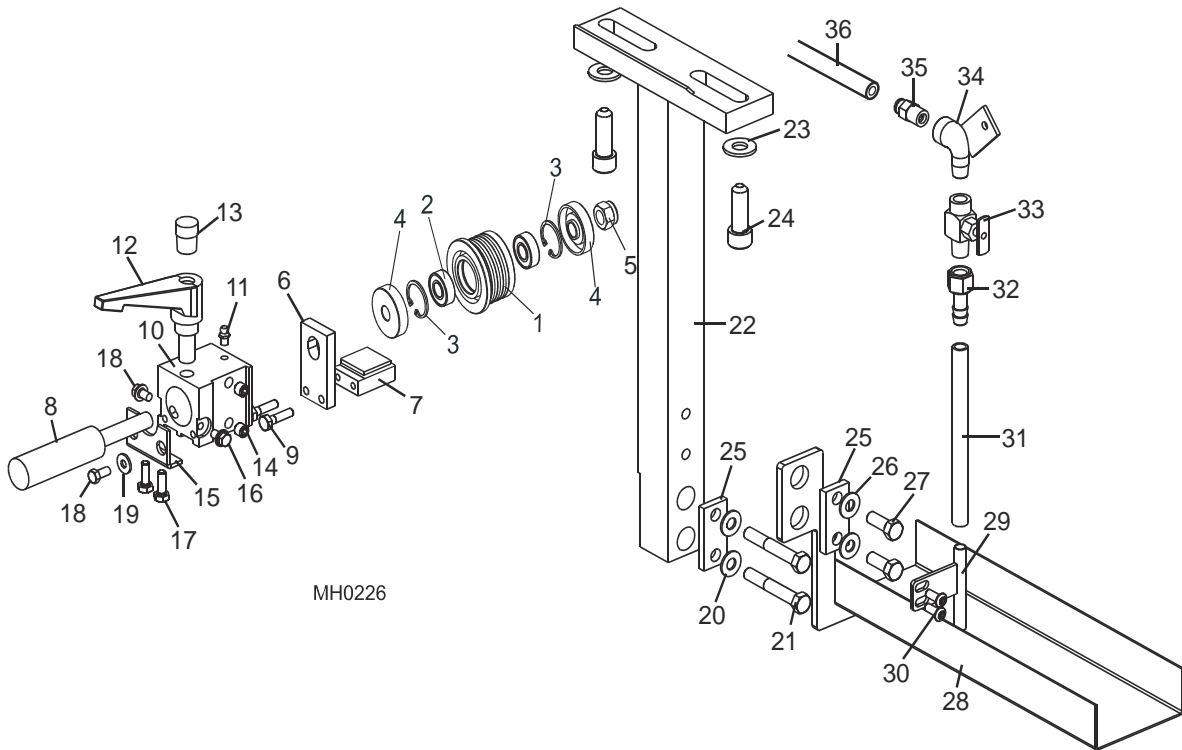

MH0226

REF	DESCRIPTION (◆ Indicates Parts Available In Assemblies Only)	PART #	QTY. (* /head)
	GUIDE ASSEMBLY, OUTER BLADE GUIDE (1" BLADE)	035261	1*
	Roller, Blade Guide Narrow W/Bearings	088261	1
1	Roller, Blade Guide Narrow	087889	1
2	Bearing, 6001 2RSR NACHI	087893	2
3	Ring, W28 Inside Retaining	F81090-9	2
4	Washer, Spacer	087891-1	2 (1)
5	Nut, M12-8 Hex Nylon Zinc Lock	F81034-2	1
	Guide Assembly w/Roller	095957 ¹	1
6	Plate, Blade Guide Mount Back	095958-1	1
7	Block, Blade Guide Complete	096954-1	1
8	Shaft, Blade Guide Zinc	095080-1	1
9	Bolt, M6X20mm, HH, Full Thread, Zinc	F81001-2	2
10	Block, Blade Guide Mounting (Outer)	S22582	1
11	Fitting, 1/4-28 Grease	P05060	1
12	Handle, Blade Guide Adjustment	P22595	1
13	Cap, Blade Guide Handle	P22668	1
14	Screw, 3/8-24 x 3/8" Nylon Lock Set	F05007-89	2

2

Saw Head Parts

Outer Blade Guide Assembly (1" Blade)

	Upgrade Kit, Blade Guide Rear Alignment Plate	A22420	1*	
15	Plate, Rear Blade Guide Alignment	S22584	1	◆
16	Screw, 1/4-20 x 3/8" Flanged	F05005-78	2	
17	Bolt, 1/4-20 x 3/4" Hex Head	F05005-1	2	
18	Bolt, 1/4-20 x 1/2" Hex Head	F05005-15	2	
19	Washer, 1/4" Flat	F05011-11	2	
	Instruction Sheet, Upgrade Kit, Blade Guide Rear Alignment	A22420-256	1	◆
20	Washer, 3/8" SAE Flat	F05011-3	2	
21	Bolt, 3/8-24 x 2 1/2" Hex Head Grade 5	F05007-81	2	
22	ARM, OUTER BLADE GUIDE MOUNTING	W22412	1*	
23	WASHER, 1/2" SAE FLAT	F05011-2	2*	
24	BOLT, 1/2-20 X 1 1/2" SOCKET HEAD	F05008-44	2*	
25	PLATE, BLADE GUIDE WASHER	S22202	2*	
26	WASHER, 3/8" SAE FLAT	F05011-3	2*	
27	BOLT, 3/8-24 X 1" HEX HEAD GRADE 5	F05007-46	2*	
28	GUARD, OUTER BLADE GUIDE	W22416	1*	
29	BRACKET, WATER LUBE TUBE	W22413	1*	
30	SCREW, 1/4-20 X 5/8" BUTTON HEAD	F05005-63	2*	
31	HOSE, 3/8 I.D. X 1/2" O.D. PLASTIC	R01885	As Req'd	
32	FITTING, 1/4" FPT - 3/8" HOSE	P04688	1*	
33	VALVE, WATER SHUTOFF	P05680	1*	
34	ELBOW WELDMENT	W21568	1*	
35	FITTING, 1/4" NPT X 1/4" TUBE	P20903	1*	
36	HOSE, 1/4" O.D. PLASTIC	R01869	As Req'd	

¹ Includes 088261 - Blade Guide Roller with Bearings.

2.7 Up/Down Assembly

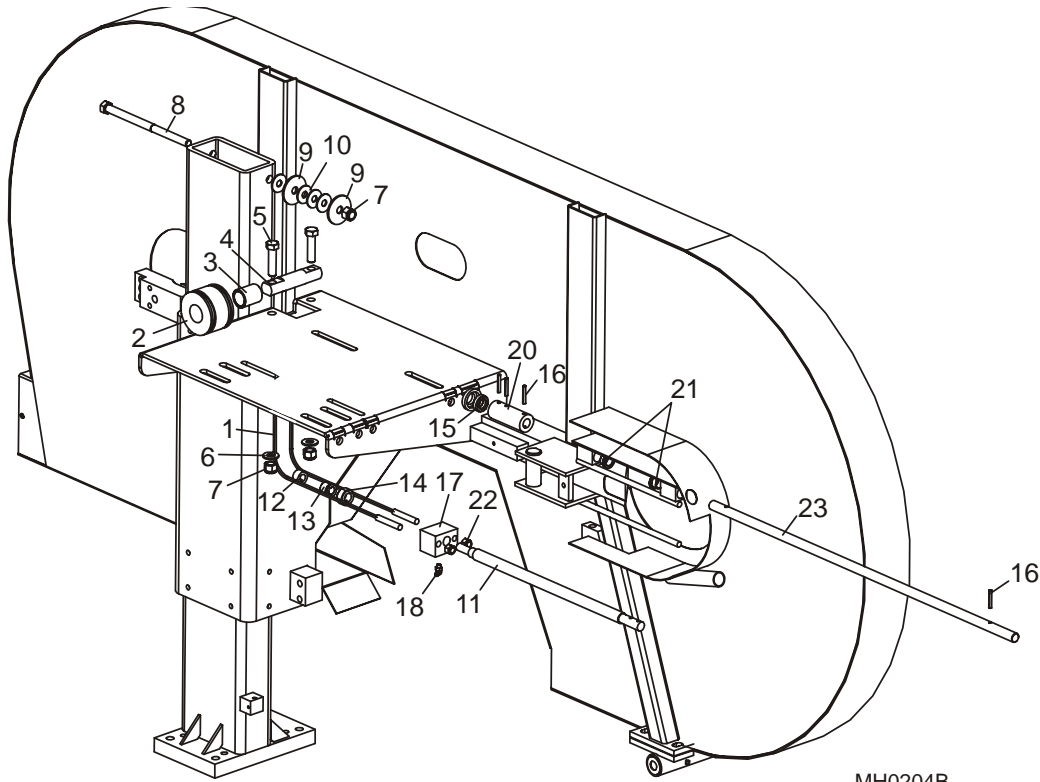

MH0204B

REF	DESCRIPTION (◆ Indicates Parts Available In Assemblies Only)	PART #	QTY. (* /head)
	UP/DOWN ASSEMBLY	A22460	1*
1	Cable, MultiHead Up/Down	S22307	1
2	Pulley, 2-Groove Up/Down Cable	S22205	1
3	Bushing, 1" x 1 1/4" x 1 1/2" Bronze	P05041	1
4	Pin, Cable Pulley Mount	S22203	1
5	Bolt, 1/2-13 x 2" Hex Head Full Thread	F05008-8	2
6	Washer, 1/2" SAE Flat	F05011-2	2
7	Nut, 1/2-13 Hex Nylon Lock	F05010-8	3
8	Bolt, 1/2-13 x 8" Hex Head Grade 5	F05008-69	1
9	Washer, 1/2" I.D. x 2" O.D. Fender	F05011-38	2
10	Washer, 7/16" Standard Flat	F05011-35	4
11	Rod, Up/Down Threaded	S22208	1
12	Collar, 1/2" I.D. Shaft	014820	1
13	Bushing, 1/2" x 3/4" Flanged Bronze	P22317	1
14	Collar, 5/8" I.D. Shaft	P05035	1
15	Bearing, 5/8" Thrust	P04214	1
16	Pin, 3/16" x 1 1/4" Roll	F05012-16	4

2**Saw Head Parts***Up/Down Assembly*

17	Block, Up/Down Threaded	S22209	1	
18	Fitting, 1/4-28 90° Grease	P04108	1	
19	Screw, 1/4-20 x 3/8" Socket Head Cup Point Set	F05005-47	2	
20	Coupling, Up/Down Crank	S22476	1	
21	Bushing, .635 ID x .750 OD Nylon Flanged	P22478 ¹	2	
22	Nut, 3/8-16 Hex Nylon Lock	F05010-10	2	
23	Shaft, Up/Down Adjustment	S22475	1	

¹ Replaces P04652 originally supplied before 9/94.

2.8 Blade Wheel Assembly (Drive Side)

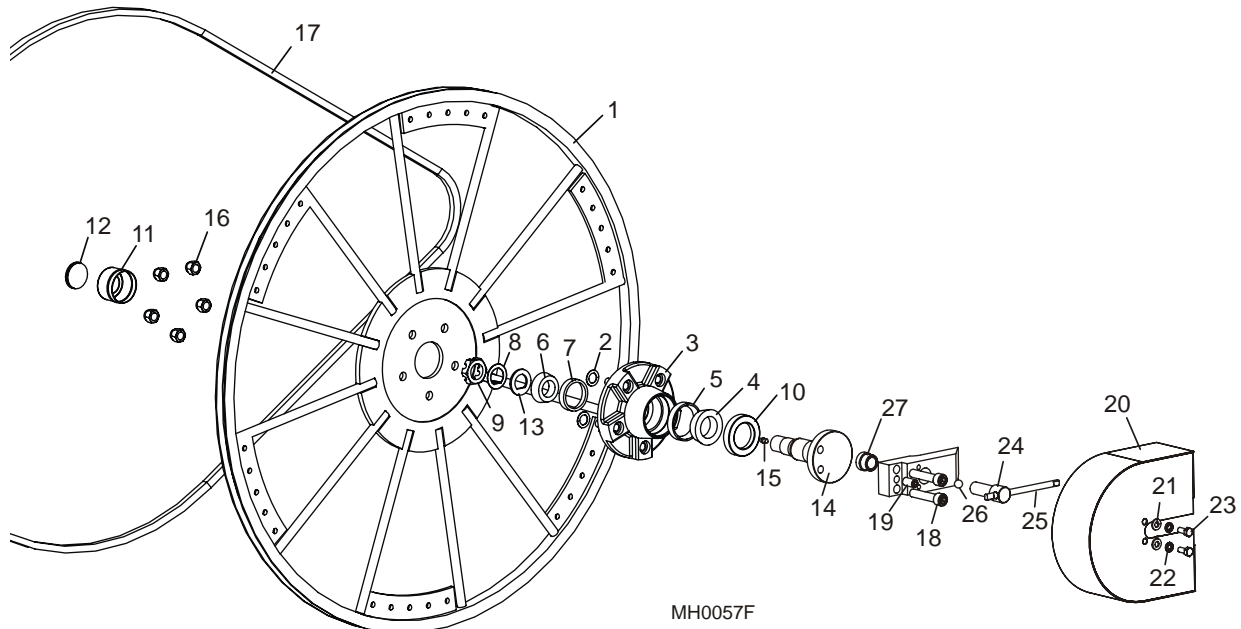

REF	DESCRIPTION (◆ Indicates Parts Available In Assemblies Only)	PART #	QTY. (*/head)	
1	WHEEL, 34" MULTIHEAD BLADE	033390	1*	
	HUB ASSEMBLY, MULTIHEAD BLADE WHEEL	A22608	1*	
2	Shim, Blade Wheel Balancing	P22611	2	
3	Hub, MultiHead Blade Wheel	022106	1	◆
	Bearing Kit, MultiHead Hub Replacement	A22594	1	
4	Bearing, Large Hub	P22572-1	1	◆
5	Sleeve, Large Hub Bearing	P22572-2	1	◆
6	Bearing, Small Hub	P22573-1	1	◆
7	Sleeve, Small Hub Bearing	P22573-2	1	◆
8	Retainer, Hub Bearing	P22686	1	
9	Nut, Hub Bearing Castle	P22776	1	
10	Seal, Rear Hub Bearing	P22574	1	
	Instruction Sheet, Hub Bearing Replacement	A22594-413	1	
	Cover Assembly, Hub Bearing Dust	A22613	1	
11	Cover, Hub Bearing Dust	P22610	1	◆
12	Insert, Rubber Hub Bearing Cover	P22612	1	◆
13	Washer, #5-23 Dexter Flat	022105	1	
	Spindle Assembly, MultiHead Blade Wheel w/Lube Fitting	022263-1	1	
14	Spindle, MultiHead Blade Wheel	S22264	1	◆
15	Fitting, 1/4-28 Grease	P05060	1	
16	Nut, 1/2-20 Hex Nylon Lock	F05010-15	5	

2

Saw Head Parts

Blade Wheel Assembly (Drive Side)

17	BELT, 5VX1210 (25HP)	033389	1	
18	SCREW, 1/2-20 X 1 1/2" SOCKET HEAD CAP	F05008-44	2*	
19	SCREW, 1/2-13 X 1" OVAL POINT SET NYLON LOCK	F05008-9	1*	
20	COVER WELDMENT, DRIVE SIDE BLADE WHEEL HUB	W22061	1*	
21	WASHER, 5/16" SAE FLAT	F05011-17	2*	
22	WASHER, 5/16" SPLIT LOCK	F05011-13	2*	
23	BOLT, 5/16-18 X 3/4" HEX HEAD GRADE 2	F05006-5	2*	
	HANDLE ASSEMBLY, DRIVE WHEEL TILT	A11309	1*	
24	Screw, Cant Adjustment	S11058	1	◆
25	Pin, Cant Assembly Slide	S22903	1	◆
26	Ball, 1/2" Diameter Detent	P02720	1	
27	BUSHING, 3/4-32 THREADED	S22876	1*	

2.9 Blade Wheel Assembly (Idle Side)

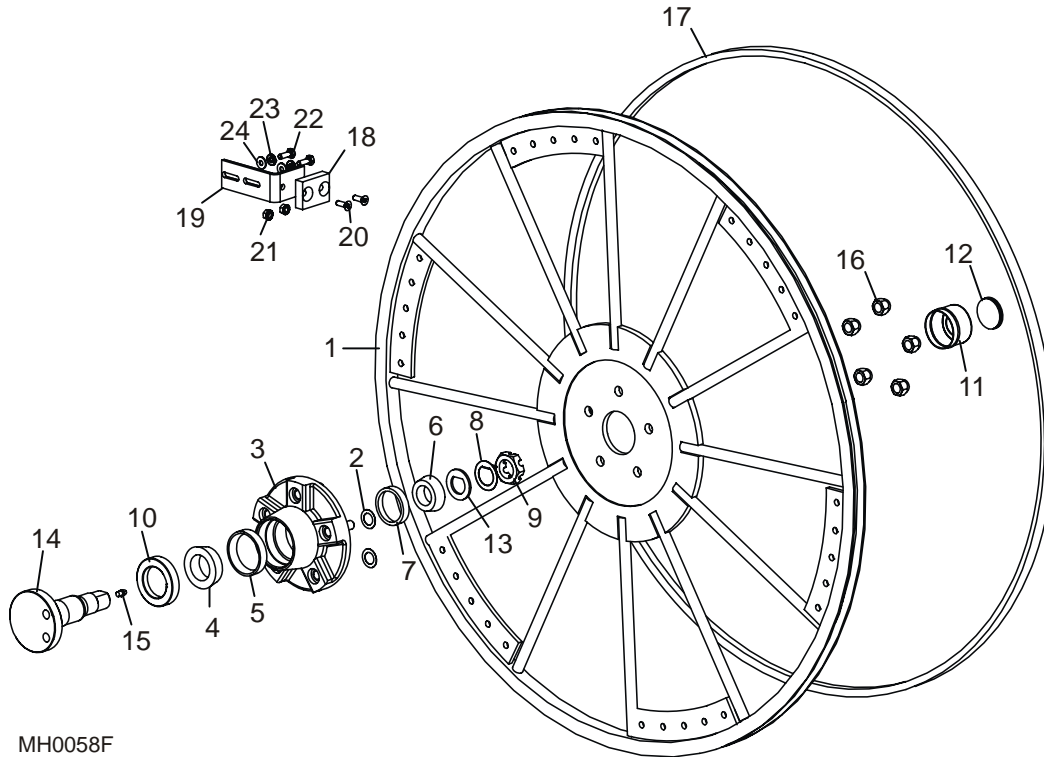

MH0058F

REF	DESCRIPTION (◆ Indicates Parts Available In Assemblies Only)	PART #	QTY. (* /head)	
1	WHEEL, 34" MULTIHEAD BLADE	033390	1*	
	HUB ASSEMBLY, MULTIHEAD BLADE WHEEL	A22608	2*	
2	Shim, Blade Wheel Balancing	P22611	2	
3	Hub, MultiHead Blade Wheel	022106	1	◆
	Bearing Kit, MultiHead Hub Replacement	A22594	1	
4	Bearing, Large Hub	P22572-1	1	◆
5	Sleeve, Large Hub Bearing	P22572-2	1	◆
6	Bearing, Small Hub	P22573-1	1	◆
7	Sleeve, Small Hub Bearing	P22573-2	1	◆
8	Retainer, Hub Bearing	P22686	1	
9	Nut, Hub Bearing Castle	P22776	1	
10	Seal, Rear Hub Bearing	P22574	1	
	Instruction Sheet, Hub Bearing Replacement	A22594-413	1	
	Cover Assembly, Hub Bearing Dust	A22613	1	
11	Cover, Hub Bearing Dust	P22610	1	◆
12	Insert, Rubber Hub Bearing Cover	P22612	1	◆
13	Washer, #5-23 Dexter Flat	022105	1	
	Spindle Assembly, MultiHead Blade Wheel w/Lube Fitting	022263-1	1	

2

Saw Head Parts*Blade Wheel Assembly (Idle Side)*

14	Spindle, MultiHead Blade Wheel	S22264	1	◆
15	Fitting, 1/4-28 Grease	P05060	1	
16	Nut, 1/2-20 Hex Nylon Lock	F05010-15	5	
17	BELT, 5VX1080	033391	1	
	BRAKE PAD ASSEMBLY	A22520	1*	
	Brake Pad Assembly	A22901	1	◆
18	Pad, Wheel Brake	S22200	1	
19	Bracket, Brake Pad Mount	S22201	1	
20	Screw, 1/4-20 x 3/4" Flat Socket Head	F05005-70	2	
21	Nut, 1/4-20 Hex Self-Locking	F05010-9	2	
22	Bolt, 1/4-20 x 1" Hex Head Full Thread	F05005-1	2	
23	Washer, 1/4" Split Lock	F05011-14	2	
24	Washer, 1/4" SAE Flat	F05011-11	2	

2.10 Blade Housing Cover

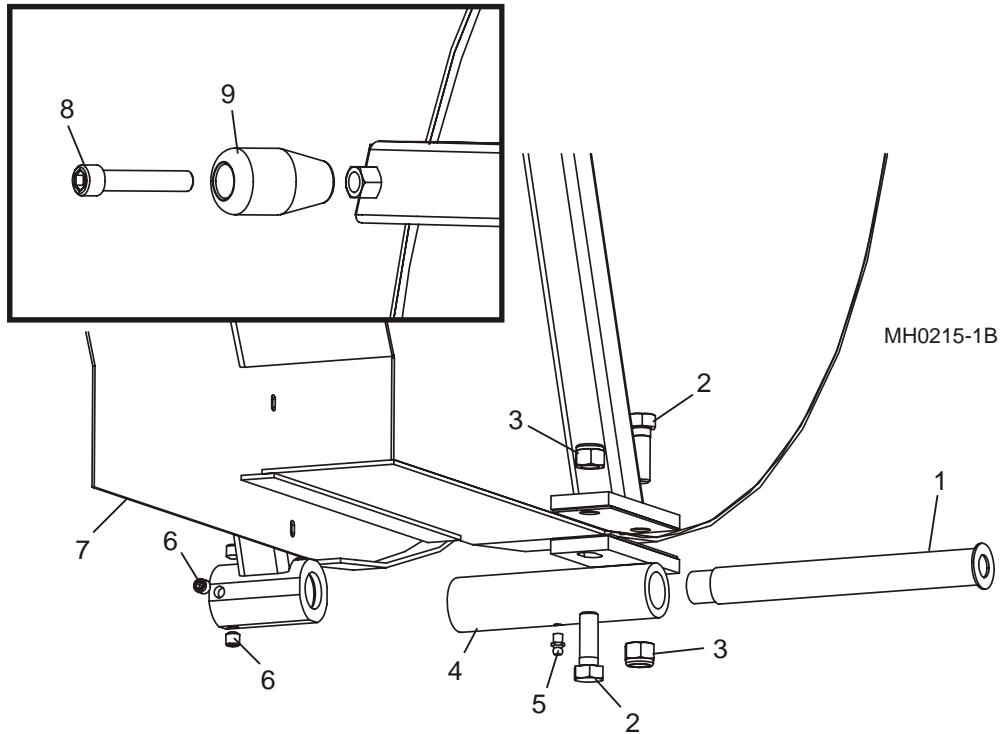

REF	DESCRIPTION (◆ Indicates Parts Available In Assemblies Only)	PART #	QTY. (*head)
1	PIN WELDMENT, COVER PIVOT	W22064	1
2	BOLT, 1/2-13 X 1 1/2" HEX HEAD UNPLATED	F05008-3	2
3	NUT, 1/2-13 HEX NYLON LOCK	F05010-8	2
4	TUBE WELDMENT, COVER PIVOT	W22623	1
5	FITTING, 1/4-28 GREASE	P05060	1
6	SCREW, 3/8-16 X 3/8" SOCKET HEAD OVAL POINT SET	F05007-13	4
7	COVER WELDMENT, MULTIHEAD BLADE HOUSING (12" THROAT)	W22435	1
8	BOLT, 3/8-16 X 2" SOCKET HEAD	F05007-58	1
9	KNOB, COVER PIVOT	S08291-W	1

2 Saw Head Parts

Safety decals, Multihead

2.11 Safety decals, Multihead

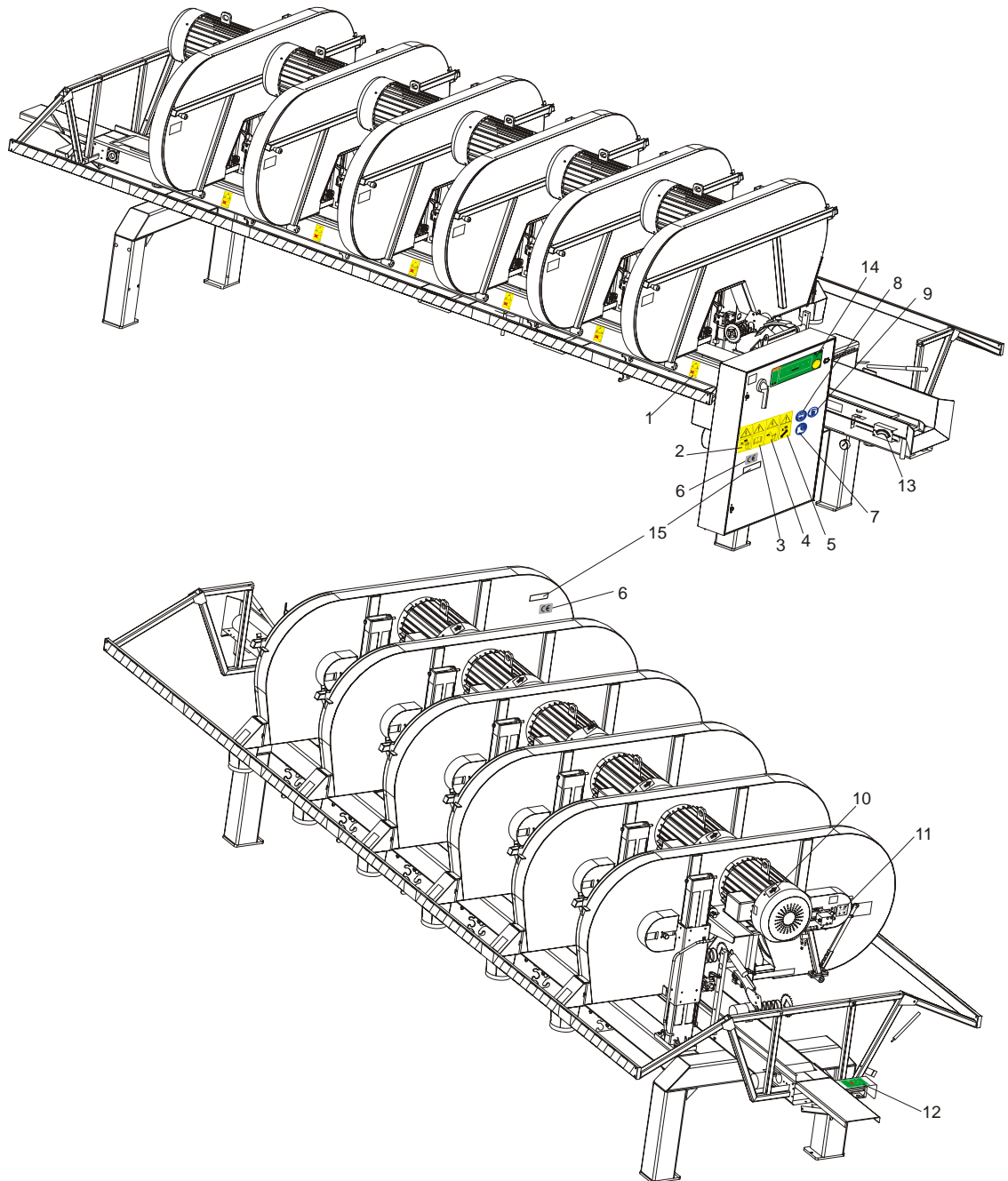

L.P.	DESCRIPTION (◆ Indicates Parts Available In Assemblies Only)	NUMER KAT.	SZT.
	SAFETY DECALS, MULTIHEAD	502041	1
1	DECAL, GEAR WARNING	099540	6
2	DECAL, REMOVE THE PLUG BEFORE OPENING THE ELECTRIC BOX	096319	1

3	DECAL, READ OPERATOR'S MANUAL (PICTOGRAM)	096317	1	
4	DECAL, HAZARDOUS VOLTAGE INSIDE THE ELECTRIC BOX (PICTOGRAM)	096316	1	
5	DECAL, DISCONNECT POWER SUPPLY BEFORE SERVICING	098177	1	
6	DECAL, CE CERTIFIED SAWMILL (SMALL)	P85070	2	
7	DECAL, USE SAFETY BOOTS	501465	1	
8	DECAL, EYE PROTECTION WARNING (PICTOGRAM)	S12004G	1	
9	DECAL, EAR PROTECTION WARNING (PICTOGRAM)	S12005G	1	
10	DECAL, MOTOR ROTATION DIRECTION (PICTOGRAM)	S20097_e	6	
11	DECAL, BLADE ALIGNMENT	P11789	6	
12	DECAL, ADDITIONAL CONTROL PANEL	502042	1	
13	DECAL, TRACK FEED RATE SCALE	502043	1	
14	DECAL, MULTIHEAD CONTROL PLATE	090928	1	
15	DECAL, SERIAL NUMBER			

SECTION 3 FEED TRACK/FRAME PARTS

3.1 Hydraulic Blade Tensioner Assembly

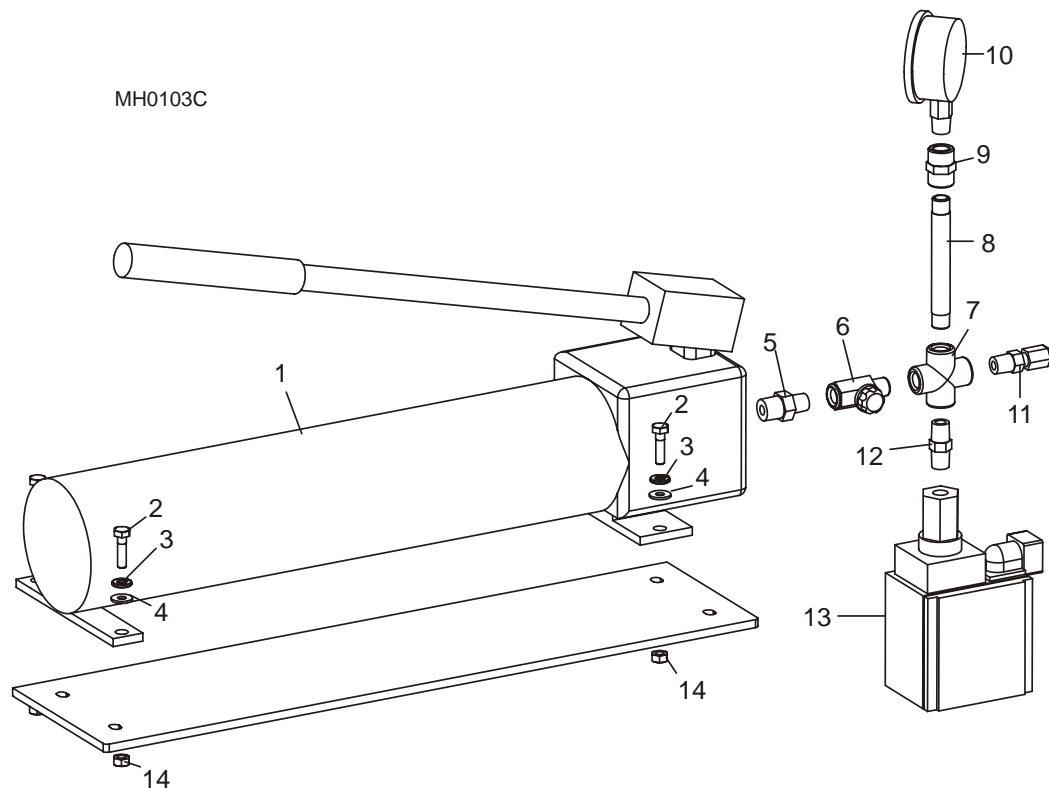

REF	DESCRIPTION (◆ Indicates Parts Available In Assemblies Only)	PART #	QTY.	
1	PUMP, HYDRAULIC 2-STAGE HAND (1-4 HEADS)	P22302	1	
	PUMP, HYDRAULIC 2-STAGE HAND (5-6 HEADS)	P22310	1	
2	BOLT, 1/4-20 X 1" HEX HEAD	F05005-101	4	
3	WASHER, 1/4" SPLIT LOCK	F05011-14	4	
4	WASHER, 1/4" SAE FLAT	F05011-11	4	
5	FITTING, 3/8" NPT - 1/4" NPT STRAIGHT	P05381	1	
6	VALVE, HYDRAULIC SHUTOFF	P22314	1	
7	FITTING, 1/4" NPT CROSS	P22311	1	
8	FITTING, 1/4" NPT X 4" NIPPLE	016428	1	
9	FITTING, 1/4" NPT COUPLING	P03420	1	
10	GAUGE, 3000 PSI HYDRAULIC	P10052	1	
11	FITTING, 1/4" NPT X 1/4" TUBE	P22518	1	
12	FITTING, 1/4" NPT STRAIGHT	P05389	1	
13	SWITCH, HYDRAULIC PRESSURE SHUT-OFF	E22726	1	
14	NUT, 1/4-20 HEX	F05010-63	4	

3.2 Perimeter Fence Assembly

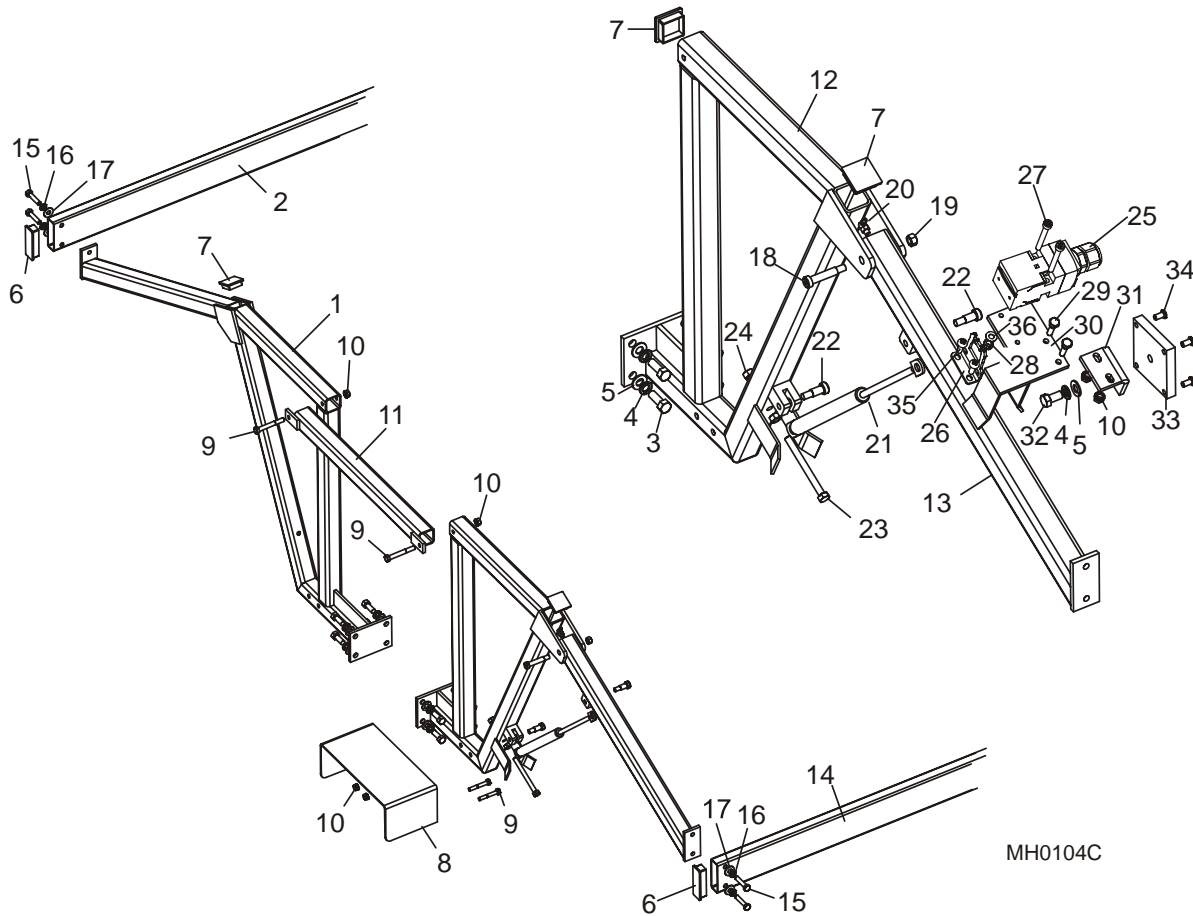

REF	DESCRIPTION (◆ Indicates Parts Available In Assemblies Only)	PART #	QTY.
1	BRACKET, FIXED PERIMETER FENCE MOUNT	W22168	2
2	TUBE, FIXED PERIMETER FENCE	S22167-X*	1
3	BOLT, 3/8-16 X 1" HEX HEAD	F05007-7	16
4	WASHER, 3/8" SPLIT LOCK	F05011-4	17
5	WASHER, 3/8" SAE FLAT	F05011-3	17
6	PLUG, 1" X 3" PLASTIC	P22522	4
7	PLUG, 1 1/2" SQUARE PLASTIC	P22321	5
8	GUARD WELDMENT, REMOTE CONTROL SWITCH	W22081	1
9	BOLT, 5/16-18 X 2 1/2" HEX HEAD	F05006-10	4
10	NUT, 5/16-18 SELF-LOCKING HEX	F05010-20	4
11	TUBE, PERIMETER FENCE CROSS	W22185	1
12	BRACKET, SWINGING PERIMETER FENCE MOUNT	W22441	2
13	ARM, SWINGING PERIMETER FENCE	W22179	2
14	TUBE, SWINGING PERIMETER FENCE	S22164-X*	1

3

Feed Track/Frame Parts

Perimeter Fence Assembly

15	BOLT, 5/16-18 X 1 1/2" HEX HEAD FULL THREAD	F05006-2	8	
16	WASHER, 5/16" SPLIT LOCK	F05011-13	8	
17	WASHER, 5/16" SAE FLAT	F05011-17	8	
18	BOLT, 3/8" X 2" SHOULDER (5/16-18 THREAD)	F05006-26	2	
19	NUT, 5/16-18 LOCK	F05010-6	2	
20	FITTING, 1/4-28 90°GREASE	P04108	2	
21	PISTON, PERIMETER FENCE GAS	P22309	2	
22	BOLT, 3/8" X 5/8" SHOULDER (5/16-18 THREAD)	F05007-79	4	
23	BOLT, 5/16-18 X 3 1/2" HEX HEAD FULL THREAD	F05006-3	2	
24	NUT, 5/16-18 HEX	F05010-17	4	
25	SWITCH, AZ17-11ZRK SAFETY	094232	1	
26	KEY, A217/170-B5 SAFETY SWITCH	094422	1	
27	SCREW, M4X35-8.8 HEX SOCKET HEAD CAP ZINC	F81011-34	4	
28	NUT, M4-B HEX NYLON ZINC LOCK	F81029-1	2	
29	BOLT, 1/4-20 X 1" HEX HEAD GRADE 5	F05005-101	2	
30	BRACKET, PERIMETER FENCE SAFETY SWITCH MOUNTING	W22246	1	
31	BRACKET, PERIMETER FENCE SWITCH "L"	S22243	1	
32	BOLT, 3/8-16 X 3/4" HEX HEAD GRADE 2	F05007-27	1	
33	PLATE, PERIMETER FENCE SAFETY SWITCH	033398	1	
34	SCREW, 1/4-20 X 1/2" BUTTON SOCKET HEAD	F05005-59	4	
35	SCREW, M4X12-5.8-B CROSS RECESSED PAN HEAD ZINC	F81011-43	2	
36	WASHER, 4.3 FLAT ZINC	F81051-2	2	
*X =Number Of Saw Heads				

3.3 Feed Track Assembly

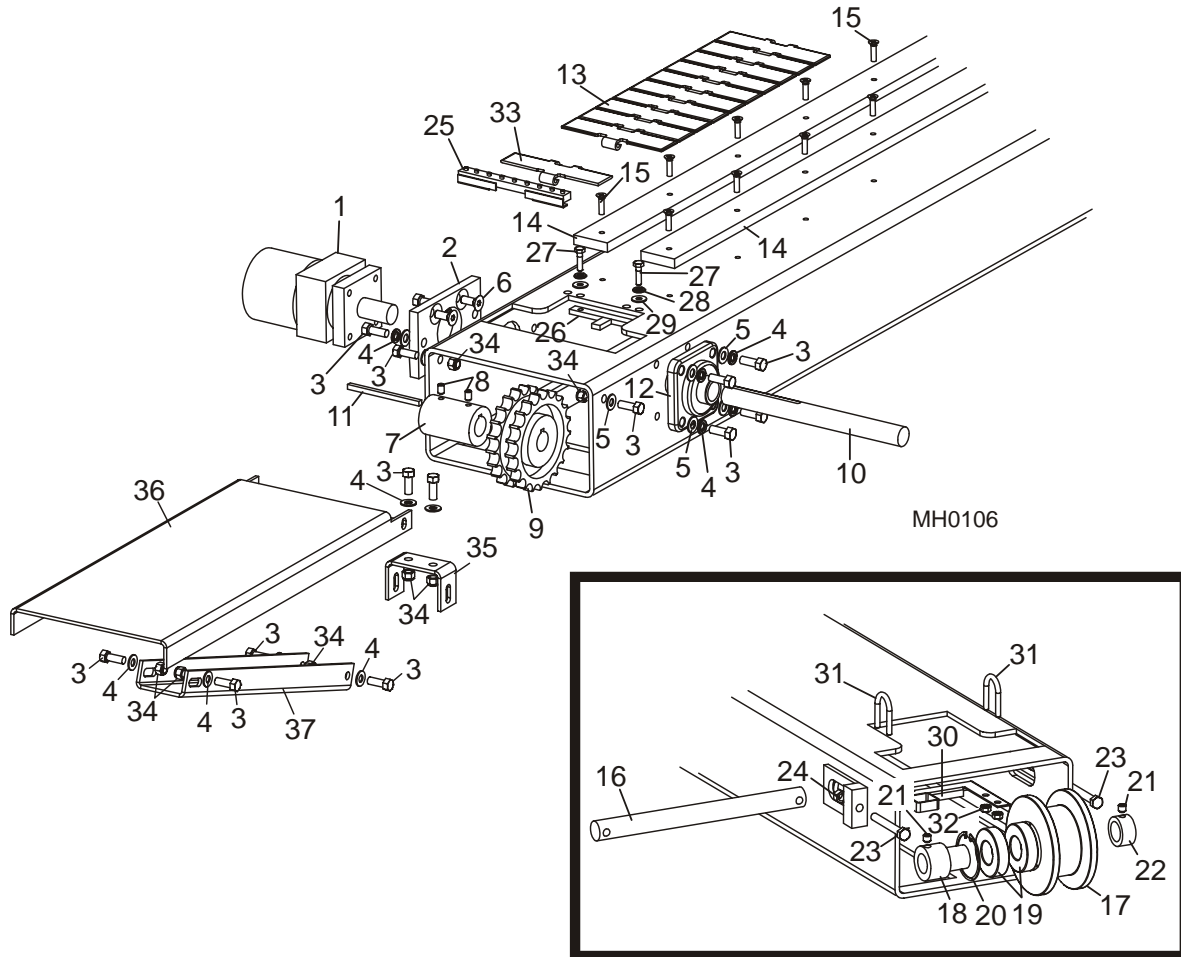

MH0106

REF	DESCRIPTION (◆ Indicates Parts Available In Assemblies Only)	PART #	QTY.	
1	MOTOR, MG10-13-10AAAB HYDRAULIC	P20206	1	
2	PLATE, FEED TRACK MOTOR MOUNT	S20173	1	
3	BOLT, 3/8-16 X 1" HEX HEAD	F05007-7	14	
4	WASHER, 3/8" SPLIT LOCK	F05011-4	6	
5	WASHER, 3/8" SAE FLAT	F05011-3	14	
6	SCREW, 3/8-16 X 1" FLAT SOCKET HEAD	F05007-64	4	
7	COUPLING, FEED TRACK MOTOR SHAFT	S20185	1	
8	SCREW, 5/16-18 X 1/2" SOCKET HEAD SET	F05006-38	2	
9	SPROCKET, 21-22T FEED TRACK DRIVE	P20202	1	
10	SHAFT, FEED TRACK DRIVE	S22428	1	
11	KEY, 1/4" SQUARE X 4.25"	S22440	1	
12	BEARING, VJC 1 FLANGED	P20201	1	
13	CHAIN, 7.5" FLAT FEED TRACK	P22427 (1 Foot)	As Req'd ¹	

3

Feed Track/Frame Parts

Feed Track Assembly

	Pin, Track Link Connecting	022424	As Req'd	
14	FEED TRACK NYLON PADS (See Section 3.4)			
15	BOLT, 1/4-20 X 3/4" HEX HEAD W/CONICAL WASHER	F05005-134	As Req'd	
16	SHAFT, FEED TRACK IDLE	S22425	1	
17	PULLEY, FEED TRACK IDLE	S20282	1	
18	BUSHING, FEED TRACK IDLE	S20286	1	
19	BEARING, 6206-2RS	P11035	2	
20	RING, 62MM INTERIOR RETAINING	F04254-12	1	
21	SCREW, 3/8-16 X 3/8" CUP POINT SET	F05007-68	2	
22	COLLAR, LOCKING	S20159-1	1	
23	BOLT, 3/8-16 X 3" HEX HEAD FULL THREAD	F05007-1	2	
24	NUT, 3/8-16 HEX	F05010-1	2	
	SAWDUST ELIMINATION KIT	A22649-12	1	
25	Rake, Feed Tube Sawdust	W22641	1	
26	Scraper, Feed Track Drive Sprocket	W22644	1	
27	Bolt, 1/4-20 x 3/4" Hex Head Full Thread	F05005-1	2	
28	Washer, 1/4" Split Lock	F05011-14	2	
29	Washer, 1/4" SAE Flat	F05011-11	2	
30	Scraper, 12" Feed Track Idle Pulley	W22652-12	1	
31	Bolt, 1/4-20 x 1 1/4" 'U'	F05005-81	2	
32	Nut, 1/4-20 Self-Locking Hex	F05010-9	4	
33	Chain, Modified 7.5" Flat Feed Track	S22426	1	
	Instruction Sheet, Sawdust Elimination Kit	A22373-440	1	
34	NUT, 3/8-16 HEX NYLON LOCK	F05010-10	8	
35	BRACKET, OFF-LOAD TABLE MOUNT	S22085	1	
36	PLATE WELDMENT, OFF-LOAD TABLE	W22438	1	
37	BRACKET, OFF-LOAD TABLE SUPPORT	S22218	1	

¹ 1 & 2 Head machines require 23' of track chain; 3 & 4 Head machines, 34'; 5 & 6 Head machines, 46'.

3.4 Feed Track Nylon Pads

Model	1/2" x 2 3/4" Nylon Pads See Qty. Below to replace entire set of track pads ¹	
	S22781 (60")	S22782 (56")
MH1D12 MH2D12	4	--
MH3D12 MH4D12	4	2
MH5D12 MH6D12	4	4

¹ All pads should be replaced in complete sets.

3

Feed Track/Frame Parts Feed Roller Assembly (Non-Air)

3.5 Feed Roller Assembly (Non-Air)

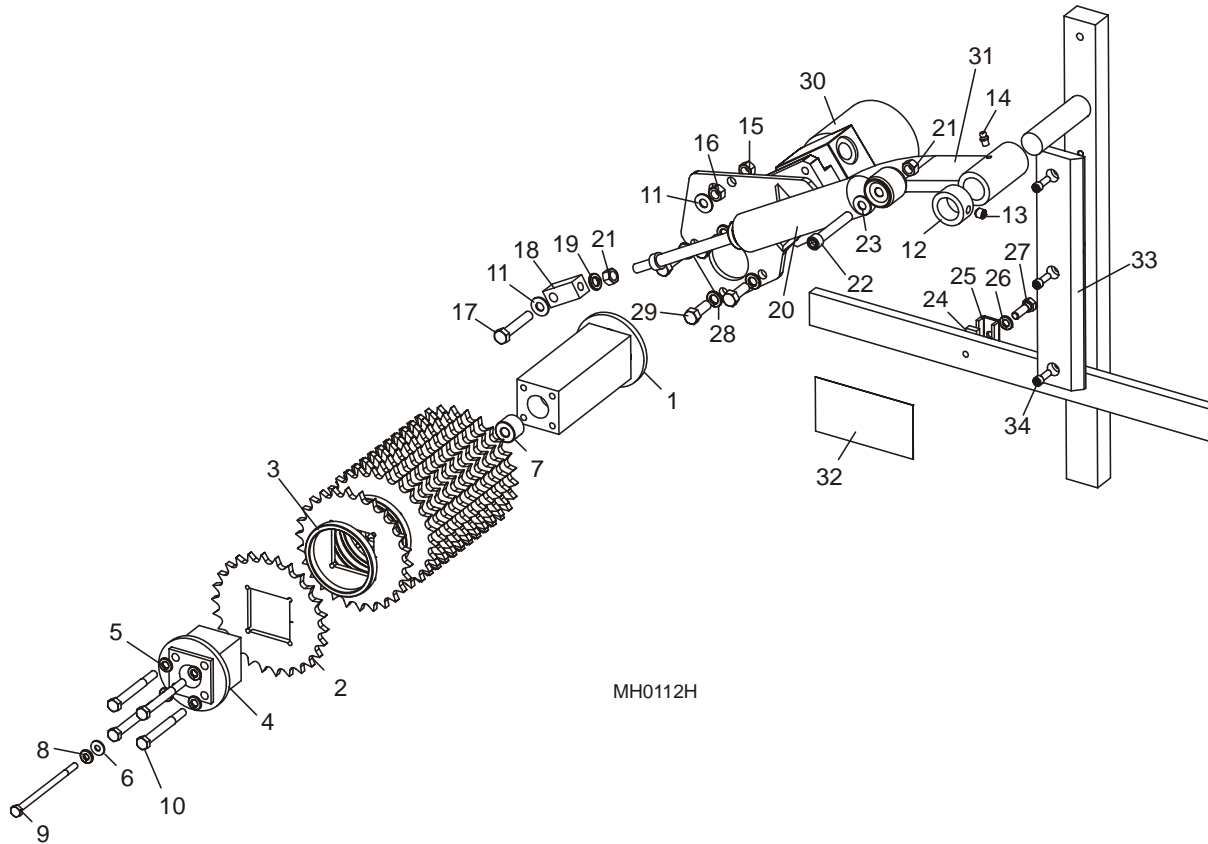

REF	DESCRIPTION (◆ Indicates Parts Available In Assemblies Only)	PART #	QTY (*/head)	
	FEED ROLLER ASSEMBLY, 12" MULTIHEAD	A22486-12	1	
1	Shaft Weldment, Feed Roller	W22485	1	◆
2	Sprocket, Feed Roller Square Shaft	S22480	13	
3	Ring, Sprocket Spacer	S22481	12	
4	Shaft Extension Weldment, Feed Roller	W22485-12	1	◆
5	Washer, 5/16" Split Lock	F05011-13	4	
6	Washer, 1/4" SAE Flat	F05011-11	1	
7	Spacer, Feed Roller Shaft	S22487	1	
8	Washer, 1/4" Split Lock	F05011-14	1	
9	Bolt, 1/4-20 x 4 1/2" Hex Head Grade 5	F05005-76	1	
10	Bolt, 5/16-18 x 3" Hex Head Grade 5	F05006-62	4	
	HANDLE, FEED ROLLER LIFT	S22488	2/machine	◆
11	WASHER, 3/8" SAE FLAT	F05011-3	2	
12	COLLAR, FEED ROLLER LOCKING	S20159-1	1	
13	SCREW, 3/8-16 X 3/8" CUP POINT SET	F05007-68	1	

Feed Track/Frame Parts
Feed Roller Assembly (Non-Air)

3

14	FITTING, 1/4-28 GREASE	P05060	1	
15	NUT, 3/8-16 HEX	F05010-1	1	
16	NUT, 3/8-16 HEX LOCK	F05010-25	1	
17	BOLT, 3/8-16 X 2" HEX HEAD FULL THREAD	F05007-16	1	
	SHOCK ASSEMBLY, FEED ROLLER	A22699	1	
18	Block, Feed Roller Piston Pivot	S20163	1	
19	Washer, 3/8" Split Lock	F05011-4	1	
20	Shock, Feed Roller J550 Gas w/Bushing Pak 148 (P20263-1)	P20263	1	◆
21	Nut, 3/8-16 Hex	F05010-1	2	
22	Bolt, 3/8-16 X 2 1/2" Socket Head	F05007-24	1	
23	Washer, 3/8" SAE Flat	F05011-3	1	
24	BUMPER, FEED ROLLER	S20906	1	
25	BRACKET, FEED ROLLER BUMPER	S20310	1	
26	WASHER, 5/16" SPLIT LOCK	F05011-13	1	
27	BOLT, 5/16-24 X 1" HEX HEAD GRADE 5	F05006-77	1	
28	WASHER, 3/8" SPLIT LOCK	F05011-4	4	
29	BOLT, 3/8-16 X 1" HEX HEAD	F05007-7	4	
30	MOTOR, MG10-13-10AAAB HYDRAULIC	P20206	1	
31	ARM, FEED ROLLER MOUNT	W22113-1	1	
32	DECAL, HAND SAFETY DANGER	S20040	1	
33	PAD, POST SLIDE	033400	1	
34	SCREW, 1/4-20 X 3/4" SOCKET HEAD	F05005-26	3	

3

Feed Track/Frame Parts Feed Roller Assembly (Air-Lift)

3.6 Feed Roller Assembly (Air-Lift)

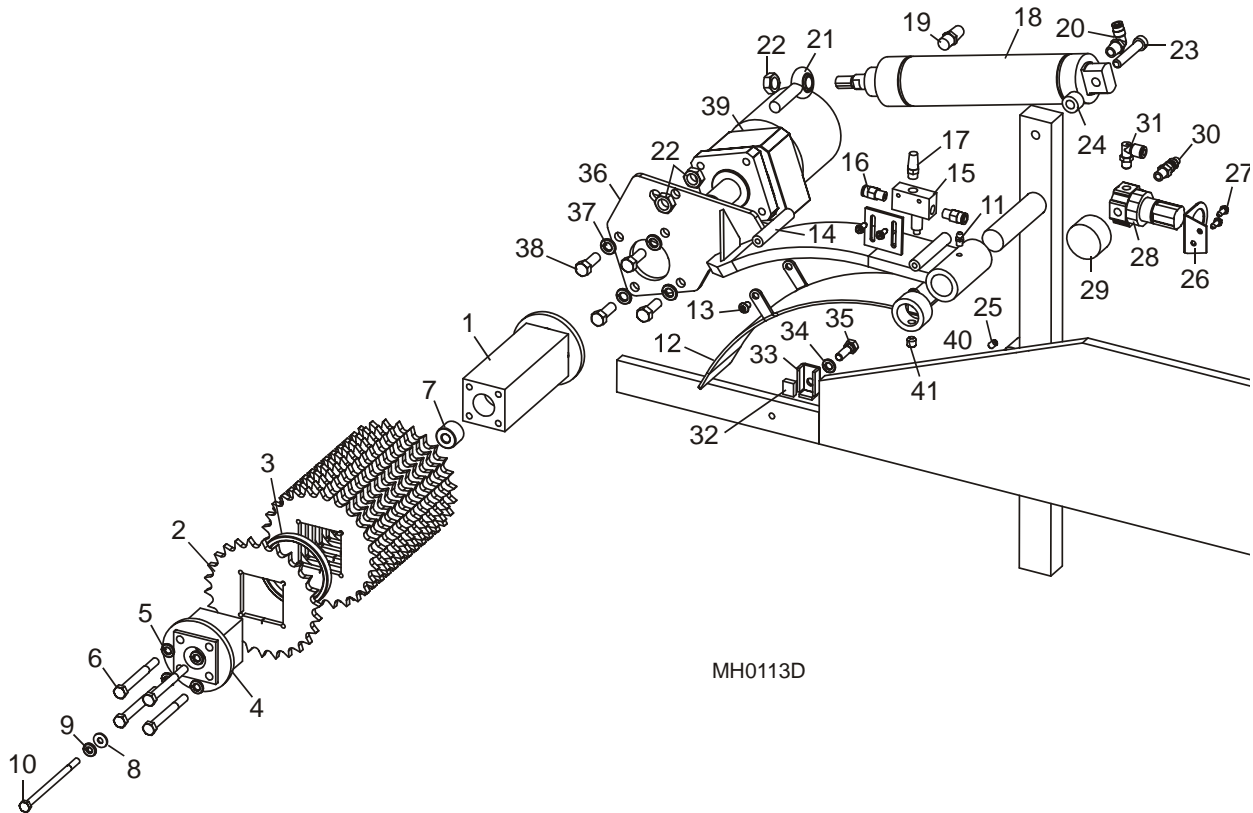

MH0113D

REF	DESCRIPTION (◆ Indicates Parts Available In Assemblies Only)	PART #	QTY.	
	FEED ROLLER ASSEMBLY, 12" MULTIHEAD	A22486-12	1	
1	Shaft Weldment, Feed Roller	W22485	1	◆
2	Sprocket, Feed Roller Square Shaft	S22480	13	
3	Ring, Sprocket Spacer	S22481	12	
4	Shaft Extension Weldment, Feed Roller	W22485-12	1	◆
5	Washer, 5/16" Split Lock	F05011-13	4	
6	Bolt, 5/16-18 x 3" Hex Head Grade 5	F05006-72	4	
7	Spacer, Feed Roller Shaft	S22487	1	
8	Washer, 1/4" SAE Flat	F05011-11	1	
9	Washer, 1/4" Split Lock	F05011-14	1	
10	Bolt, 1/4-20 x 4 1/2" Hex Head Grade 5	F05005-76	1	
	HANDLE, FEED ROLLER LIFT	S22488	2/machine	◆
11	FITTING, 1/4-28 GREASE	P05060	1	
12	BRACKET, AIR LIFT FEED ROLLER ACTUATOR	S22189	1	
13	SCREW, 1/4-20 X 3/8" BUTTON HEAD	F05005-62	4	
14	ROLLER, FEED ROLLER STOP	S20786	1	

Feed Track/Frame Parts

Feed Roller Assembly (Air-Lift)

3

15	SWITCH, FEED ROLLER AIR	P20900	1	
16	FITTING, 1/4" NPT - 1/4" TUBE STRAIGHT	P03078	2	
17	MUFFLER, 1/8" NPT AIR	P20902	1	
	TUBE, 1/4" AIR	R01869	16.5 Ft.	
18	CYLINDER, 4DP6 AIR	P20901	1	
19	MUFFLER, 1/4" NPT AIR	P20904	1	
20	FITTING, 1/4" NPT - 1/4" TUBE ELBOW	P21519	1	
21	END, 1/2-20 ROD	P09137	1	
22	NUT, 1/2-20 HEX JAM	F05010-16	3	
23	PIN, FEED ROLLER AIR CYLINDER PIVOT	S20793	1	
24	SPACER, AIR CYLINDER MOUNT	S22625	1	
25	SCREW, 1/4-20 X 3/8" CUP POINT SET	F05005-47	1	
26	BRACKET, AIR REUGLATOR MOUNT	P20799	1	
27	SCREW, 1/8-32 X 1/2" SLOTTED HEX	F05015-18	4	
28	REGULATOR, 300 PSI AIR FLOW	P02765	1	
29	GAUGE, 160 PSI AIR	P02766	1	
30	FITTING, 1/8" NPT MALE COUPLING	P22681	1	
31	FITTING, 1/8" NPT - 1/4" TUBE 90° ELBOW	P09736	1	
32	BUMPER, FEED ROLLER	S20906	1	
33	BRACKET, FEED ROLLER BUMPER	S20310	1	
34	WASHER, 5/16" SPLIT LOCK	F05011-13	1	
35	BOLT, 5/16-24 X 1" HEX HEAD GRADE 5	F05006-77	1	
36	ARM, FEED ROLLER MOUNT	W22113	1	
	DECAL, HANDS CLEAR WARNING	S20040	1	
37	WASHER, 3/8" SPLIT LOCK	F05011-4	4	
38	BOLT, 3/8-16 X 1" HEX HEAD	F05007-7	4	
39	MOTOR, MG10-13-10AAAB HYDRAULIC	P20206	1	
40	COLLAR, FEED ROLLER LOCKING	S20159-1	1	
41	SCREW, 3/8-16 X 3/8" CUP POINT SET	F05007-68	1	

3.7 Hydraulic Tank Assembly

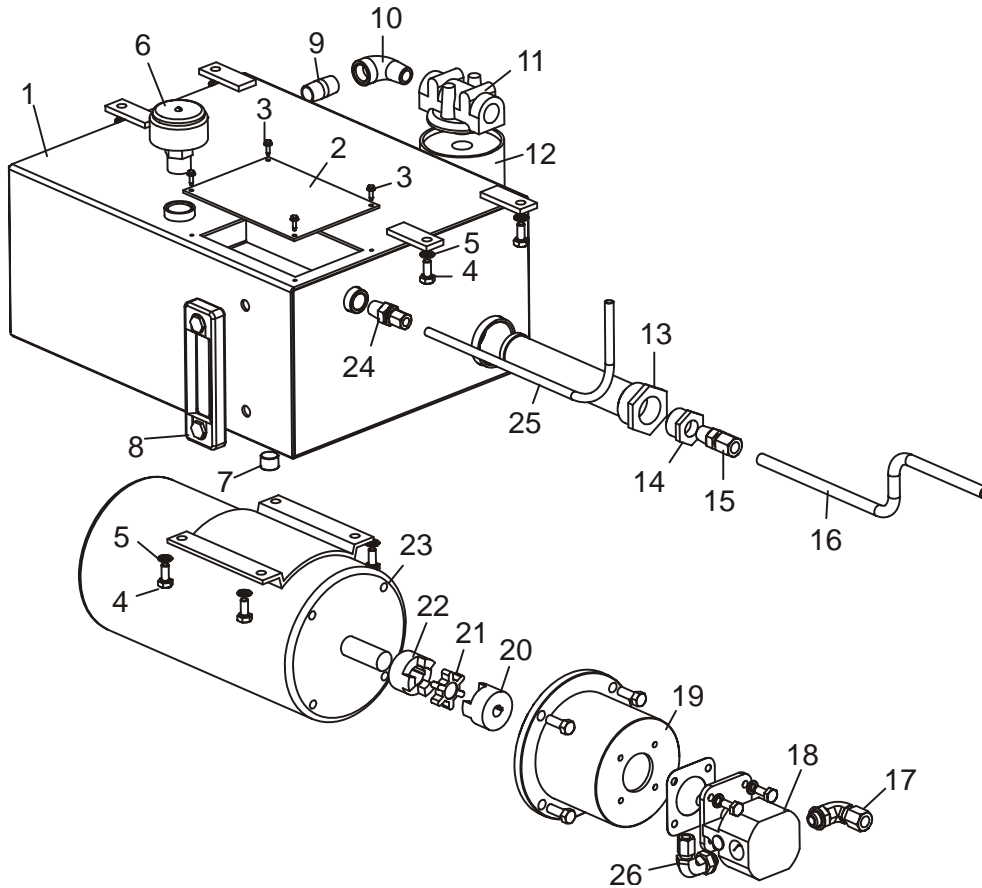

MH0107B

REF	DESCRIPTION (◆ Indicates Parts Available In Assemblies Only)	PART #	QTY.
	FLUID, EXXON UNIVIS HVI 26 ALL WEATHER HYDRAULIC (1 GALLON)	P12823 ¹	5
1	TANK, HYDRAULIC FLUID	W22108	1
2	LID, HYDRAULIC FLUID TANK ACCESS	S20331	1
3	SCREW, #8-32 X 1/2" SLOTTED HEX HEAD	F05015-18	4
4	BOLT, 5/16-18 X 3/4" HEX HEAD GRADE 2	F05006-5	8
5	WASHER, 5/16" SPLIT LOCK	F05011-13	8
6	CAP, HYDRAULIC TANK FILL/BREATHER	P20212	1
7	FITTING, 1/2" NPT MALE PLUG	P26258	1
8	GAUGE, HYDRAULIC FLUID LEVEL SIGHT	P20211	1
9	FITTING, 1 1/2" NPT X 1 1/2" LONG NIPPLE	P20237	1
10	FITTING, 1/2" NPT 90° ELBOW	P22684	1
11	MANIFOLD, HYDRAULIC CARTRIDGE FILTER	P22683	1
12	Filter, S28 Hydraulic Cartridge	P20301	1
13	FILTER, HYDRAULIC TANK SUCTION	P20210	1
14	FITTING, 1" NPT - 1/2" NPT REDUCER	P20239	1

Feed Track/Frame Parts
Hydraulic Tank Assembly

3

15	FITTING, 1/2" NPT - 1/2" TUBE	P20243	1	
16	TUBE, 1/2" HYDRAULIC	R01629	As Req'd	
17	FITTING, 1/2" TUBE - 1/2" O-RING 90° ELBOW	P20245	1	
18	PUMP, HYDRAULIC	P20213	1	
19	ADAPTOR, HYDRAULIC PUMP/MOTOR	P20215	1	
20	COUPLER, 1/2" SHAFT	P20217	1	
21	COUPLER, L075 SPIDER	P20218	1	
22	COUPLER, 7/8" SHAFT	P20216	1	
23	MOTOR, 4HP CUSTOM 3 PHASE W/THERMISTATS	P22735	1	
	MOTOR, 4HP 575V CUSTOM 3 PHASE W/THERMISTATS	P22689 ²	1	
24	FITTING, 1/2" NPT - 3/8" TUBE STRAIGHT	P20242	1	
25	TUBE, 3/8" HYDRAULIC	R01628	As Req'd	
26	FITTING, 1/2" O-RING - 3/8" TUBE 90° ELBOW	P20244	1	

¹ Replaces Amoco Rycon Oil MV or Mobil Multipurpose ATF used prior to 11/99.

² For 575 Volt MultiHeads.

3

Feed Track/Frame Parts

Hydraulic Valve Assembly (2 and 4-Head)

3.8 Hydraulic Valve Assembly (2 and 4-Head)

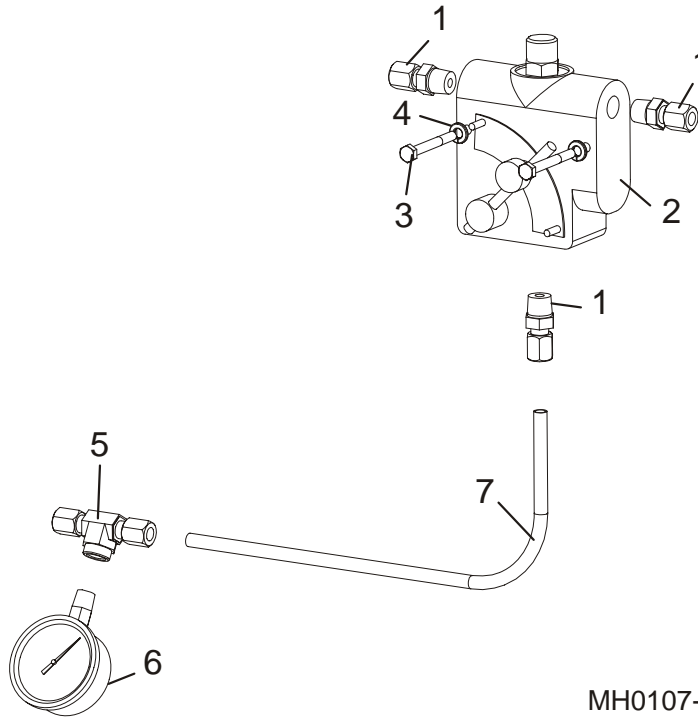

MH0107-1

REF	DESCRIPTION (◆ Indicates Parts Available In Assemblies Only)	PART #	QTY.	
1	FITTING, 3/8" TUBE - 3/8" NPT STRAIGHT	P20744	3	
2	VALVE, HYDRAULIC FLOW CONTROL	P20743	1	
3	BOLT, 1/4-20 X 2 1/2" HEX HEAD	F05005-72	2	
4	WASHER, 1/4" SPLIT LOCK	F05011-14	2	
5	FITTING, 3/8" TUBE - 1/4" NPT - 3/8" TUBE 'T'	P20345	1	
6	GAUGE, 3000 PSI COLOR-CODED FACE	P10052	1	
7	TUBE, 3/8" HYDRAULIC	R01628	As Req'd	

3.9 Hydraulic Valve Assembly (6-Head)

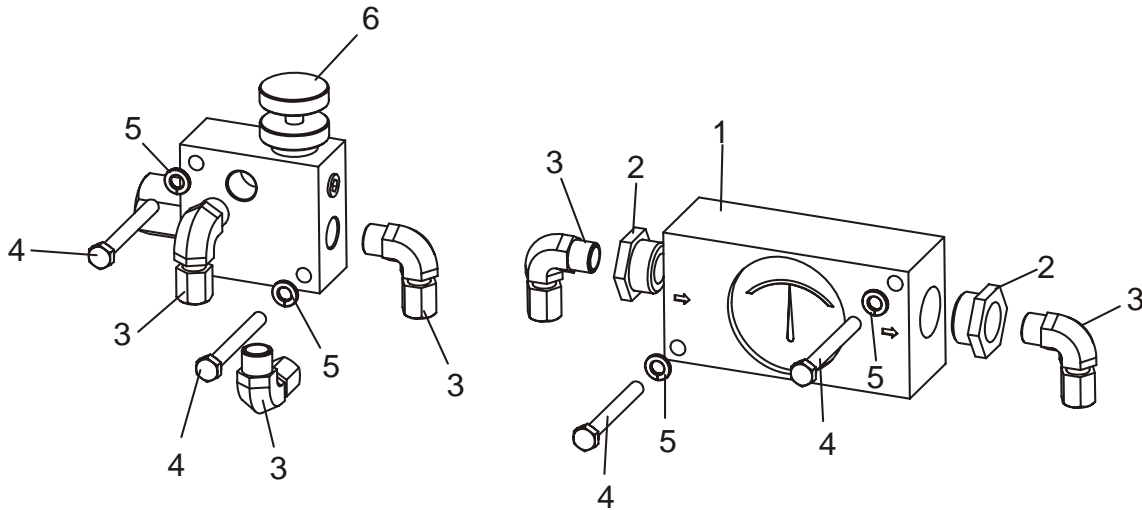

MH0107-2

REF	DESCRIPTION (◆ Indicates Parts Available In Assemblies Only)	PART #	QTY.
1	METER, FLOW	033414	1
2	BUSHING, 3/4" MPT X 3/8" FPT	033415	2
3	FITTING, 3/8" MPT X 3/8" TUBE 90°	033416	5
4	BOLT, 5/16-18 X 2" HEX HEAD GRADE 5	F05006-79	4
5	WASHER, 5/16" SPLIT LOCK	F05011-13	4
6	VALVE, 6-HEAD MERRY-GO-ROUND CONTROL	033413	1

3

Feed Track/Frame Parts

Crowder Fence Assembly

3.10 Crowder Fence Assembly

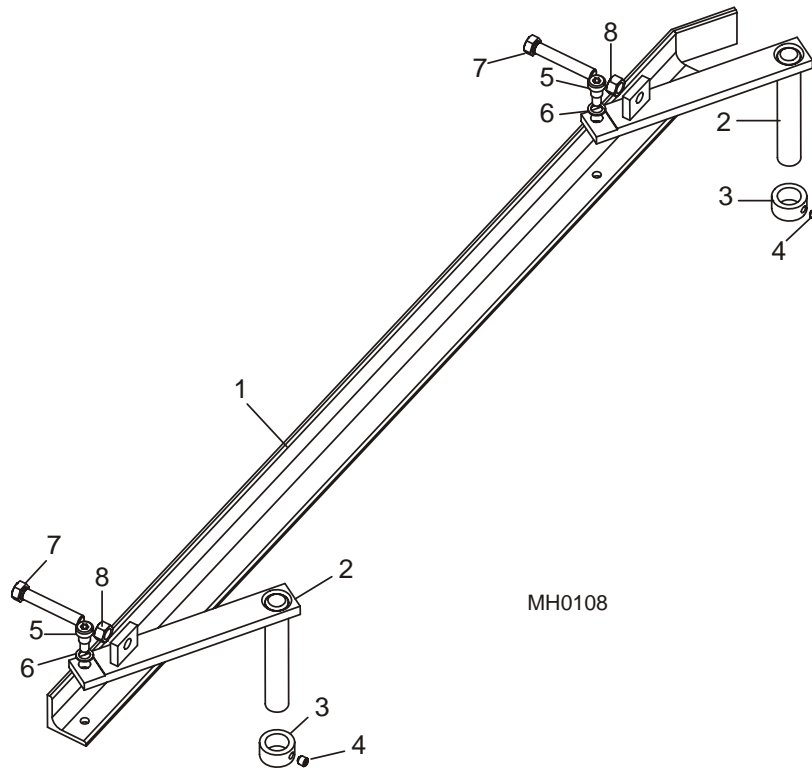

REF	DESCRIPTION (◆ Indicates Parts Available In Assemblies Only)	PART #	QTY.	
1	FENCE, FEED CROWDER	S22260	1	
2	BRACKET, CROWDER FENCE PIVOT END	W22252	2	
3	COLLAR, LOCKING	S20159-1	2	
4	SCREW, 3/8-16 X 3/8" CUP POINT SET	F05007-68	2	
5	BOLT, 1/2" X 1/2" SHOULDER	F05008-63	2	
6	WASHER, 1/2" I.D. X 3/4" O.D. X .062" THICK NYLON	P05251-1	2	
7	BOLT, 1/2-13 X 3 1/2" HEX HEAD FULL THREAD	F05008-11	2	
8	NUT, 1/2-13 HEX	F05010-35	2	

INDEX

B

- blade guide
 - inner (1" blade) 2-8
 - outer (1" blade) 2-10
- blade housing cover 2-18
- blade tensioner
 - block assembly 2-1
 - hand pump 3-1
 - release handle 2-3
- blade wheel
 - drive side 2-14
 - idle side 2-16

F

- feed roller
 - air-lift 3-9
 - standard 3-7
- feed track 3-4
- feed track spacers 3-6
- fence 3-15

H

- hydraulic tank 3-11, 3-13, 3-14

P

- parts list
 - how to use 1-1
- perimeter fence 3-2

S

- saw head mount 2-5
- saw motor 2-6

U

- up/down 2-12