

INDUSTRIAL PRODUCTS

Parts Manual

HR1000E15S
HR1000E20S
(MultiHead)

Rev.A4.01
Rev.A4.01
Rev.A4.01



Safety is our #1 concern! Read and understand all safety information and instructions before operating, setting up or maintaining this machine.

Form #739

Table of Contents

Section-Page

SECTION 1	GENERAL INFORMATION	1-1
1.1	How To Use The Parts List	1-1
1.2	Sample Assembly	1-1
SECTION 2	SAW HEAD PARTS	2-1
2.1	Blade Tensioner Assembly	2-1
2.2	Tension Release Handle Assembly	2-3
2.3	Saw Head Mount Assembly	2-5
2.4	Motor Assembly E20, E25	2-7
2.5	Motor Assembly E15	2-9
2.6	Blade Guide Roller Guard	2-11
2.7	Inner Blade Guide Assembly	2-12
2.8	Outer Blade Guide Assembly	2-13
2.9	Up/Down Assembly	2-15
2.10	Blade Wheel Assembly (Drive Side)	2-17
2.11	Blade Wheel Assembly (Idle Side)	2-19
2.12	Blade Housing Cover	2-21
2.13	Sawdust Chute	2-22
2.14	Warning Decals	2-23
SECTION 3	FEED TRACK/FRAME PARTS	3-1
3.1	Hydraulic Blade Tensioner Assembly	3-1
3.2	Perimeter Fence Assembly	3-2
3.3	Feed Track Assembly	3-4
3.4	Feed Track Nylon Pads	3-6
3.5	Feed Roller Assembly (Non-Air)	3-7
3.6	Feed Roller Assembly (Air-Lift)	3-11
3.7	Hydraulic Tank Assembly	3-13
3.8	Hydraulic Valve Assembly (2 and 4-Head)	3-15
3.9	Hydraulic Valve Assembly (6-Head)	3-16
3.10	Crowder Fence Assembly	3-17
	INDEX	1-I

SECTION 1 GENERAL INFORMATION

1.1 How To Use The Parts List

- Use the table of contents or index to locate the assembly that contains the part you need.
- Go to the appropriate section and locate the part in the illustration.
- Use the number pointing to the part to locate the correct part number and description in the table.
- Parts shown indented under another part are included with that part.
- Parts marked with a diamond (◆) are only available in the assembly listed above the part.

See the sample table below. Sample Part #A01111 includes part F02222-2 and subassembly A03333. Subassembly A03333 includes part S04444-4 and subassembly K05555. The diamond (◆) indicates that S04444-4 is not available except in subassembly A03333. Subassembly K05555 includes parts M06666 and F07777-77. The diamond (◆) indicates M06666 is not available except in subassembly K05555.

1.2 Sample Assembly				
REF	DESCRIPTION (◆ Indicates Parts Available In Assemblies Only)	PART #	QTY.	
	SAMPLE ASSEMBLY, COMPLETE (INCLUDES ALL INDENTED PARTS BELOW)	A01111	1	
1	Sample Part	F02222-22	1	
	Sample Subassembly (Includes All Indented Parts Below)	A03333	1	
2	Sample Part (◆ Indicates Part Is Only Available With A03333)	S04444-4	1	◆
	Sample Subassembly (Includes All Indented Parts Below)	K05555	1	
3	Sample Part (◆ Indicates Part Is Only Available With K05555)	M06666	2	◆
4	Sample Part	F07777-77	1	

To Order Parts:

- From the continental U.S., call **1-800-448-7881** to order parts. Have your customer number, serial number, and part numbers ready when you call.
- From other international locations, contact the Wood-Mizer distributor in your area for parts.

SECTION 2 SAW HEAD PARTS

2.1 Blade Tensioner Assembly

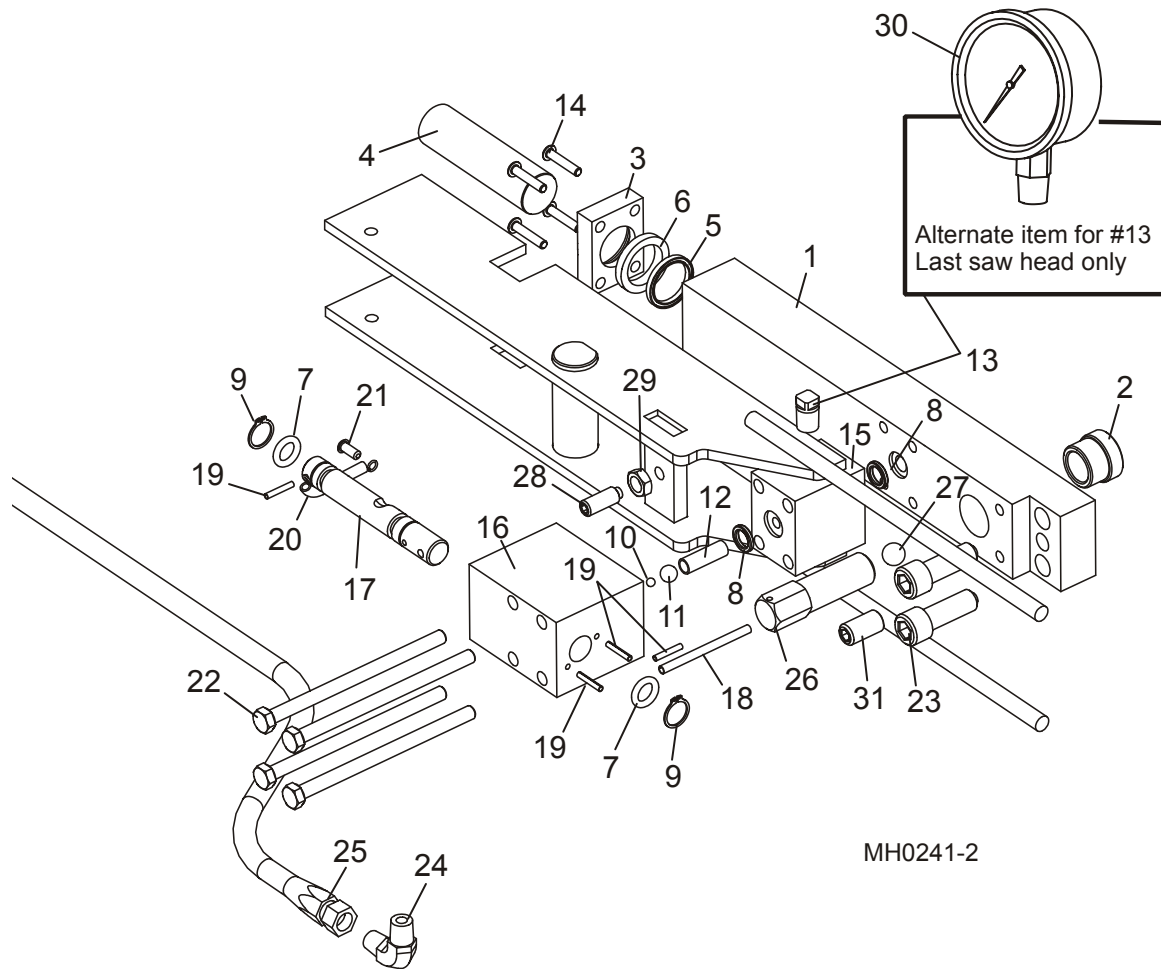

REF	DESCRIPTION (◆ Indicates Parts Available In Assemblies Only)	PART #	QTY. (* /head)
	TENSIONER ASSEMBLY, MULTIHEAD BLADE	A22220	1*
1	Bar, Blade Tensioner	022221 ¹	1
2	Bushing, 3/4-32 Threaded	S22786 ¹	1
3	Block, Tensioner Seal	S10089	1
4	Piston, Blade Tensioner	S10059	1
	Seal Kit, Hydraulic Tensioner	A22910	1
5	Seal, 1" Diameter Tensioner	P10051	1
6	Wiper, 1" Diameter Tensioner	P10053	1
7	O-Ring, Tensioner Valve Spool	P09685	2
8	O-Ring, 5/8" x 3/32" Square	P10377	2

9	Ring, 5/8" Retainer	F04254-2	2	
10	Ball, 3/16" Diameter Steel	P09744	1	
11	Ball, 3/8" Diameter Steel	P09133	1	
12	Spring, LC-038E-15SS	P22041	1	
13	Plug, 1/4" NPT Pipe	P05498	1	
14	Bolt, #10-24 Socket Button Head	F05004-43	4	
15	Block, Tensioner Valve Mount	S22213	1	
16	Block, Tensioner Valve	S22216	1	
17	Spool, Tensioner Valve	S22326	1	
18	Pin, 3/16" x 2 1/2" Roll	F05012-27	1	
19	Pin, 1/8" x 3/4" Roll	F05012-6	4	
20	Spring, LE-041C-7MW	P10064	1	
21	Screw, #7 x 1/2" Drive	F05015-25	1	
22	Bolt, 5/16-18 x 5" Hex Head Grade 8	F05006-52	4	
23	BOLT, 1/2-20 X 1 1/2" SOCKET HEAD	F05008-44	2	
24	FITTING, 1/4" NPT 90° ELBOW	P09140	1*	
25	HOSE, 1/4" DIA. X 78" HYDRAULIC W/FITTINGS	P22299	1*	
	SCREW ASSEMBLY, BLADE WHEEL TILT	007652	1*	
26	Screw, Cant Adjustment	007651	1	◆
27	Ball, 1/2" Diameter Detent	P02720	1	
28	SCREW, 3/8-16 X 1" SOCKET HEAD BRASS TIP	F05007-88	1*	
29	NUT, 3/8-16 HEX JAM	F05010-29	1*	
30	GAUGE, 3000 P.S.I BLADE TENSION	P10052	1	
31	SCREW, 1/2-13 X 1" OVAL POINT SET NYLON LOCK	F05008-9	1	

¹ Bushing S22786 is welded to tensioner block S11054. Factory removal and installation recommended. Use 022221 Tensioner Block w/Bushing for field service.

2 Saw Head Parts

Tension Release Handle Assembly

2.2 Tension Release Handle Assembly

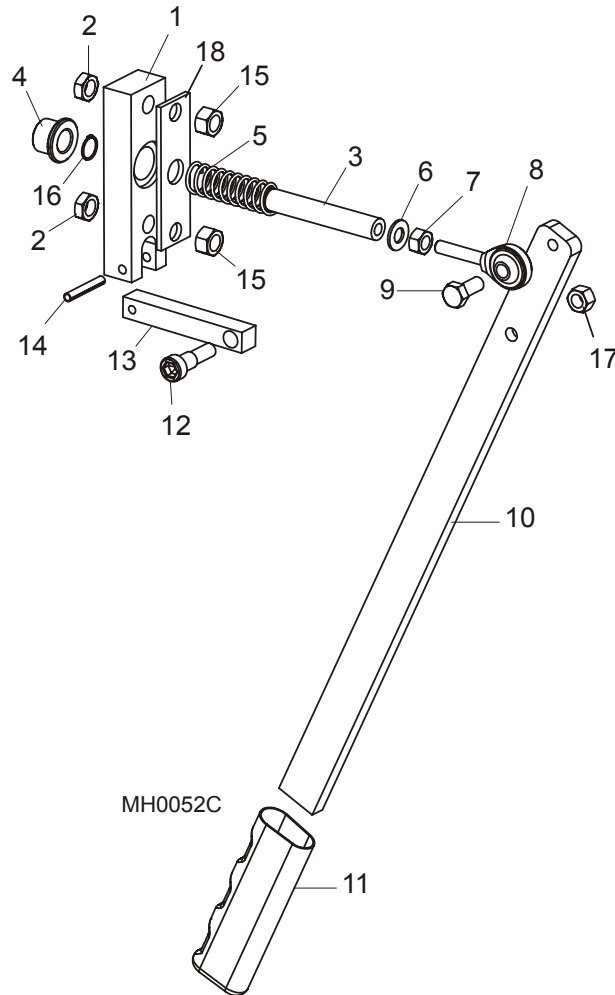

REF	DESCRIPTION (◆ Indicates Parts Available In Assemblies Only)	PART #	QTY.	
	HANDLE ASSEMBLY, TENSION RELEASE	A22528	1*	
1	Plate, Tensioner Stop	S22527	1	
2	Nut, 3/8-16 Hex Jam	F05010-29	2	
3	Rod, Tensioner Push	S22526	1	
4	Bushing, Flanged Bronze	P22662	1	
5	Spring, LC-072J-7MW	P05155	1	
6	Washer, 5/16" SAE Flat	F05011-17	1	
7	Nut, 5/16-24 Hex	F05010-28	1	
8	Rod End, 5/16-24 Male	P09814	1	
9	Bolt, 5/16-18 x 3/4" Hex Head	F05006-5	1	
10	Handle, Tension Release	S22524	1	
11	Grip, Tension Release Handle	P04731	1	
12	Bolt, 3/8" x 1/2" Shoulder	F05006-56	1	

Saw Head Parts
Tension Release Handle Assembly

2

13	Bar, Tension Release Handle Link	S22525	1	
14	Pin, 3/16" x 1 1/4" Roll	F05012-16	1	
15	Nut, 3/8-16 Hex Lock	F05010-25	2	
16	Ring, 1/2" Retainer	F04254-18	1	
17	Nut, 5/16-18 Hex Lock	F05010-6	1	
18	Plate, Bushing Retainer	036600	1	

2 Saw Head Parts

Saw Head Mount Assembly

2.3 Saw Head Mount Assembly

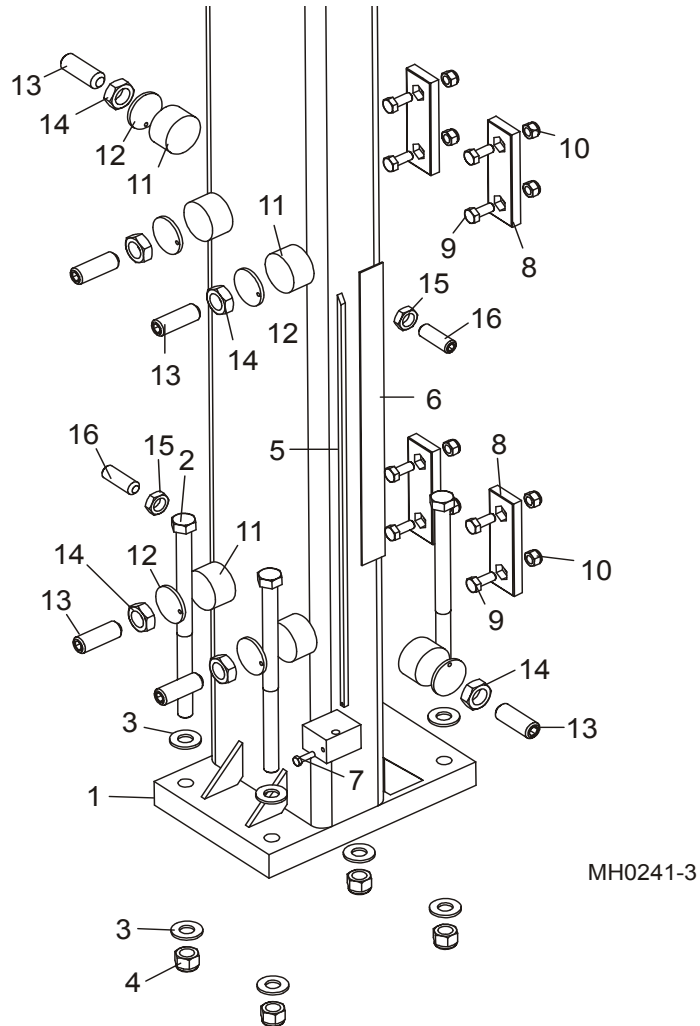

REF	DESCRIPTION (◆ Indicates Parts Available In Assemblies Only)	PART #	QTY. (* /head)
1	TUBE WELDMENT, SAWHEAD MOUNT	007682	1*
2	BOLT, 1/2-13 X 8" HEX HEAD GRADE 5	F05008-69	4*
3	WASHER, 1/2" SAE FLAT	F05011-2	8*
4	NUT, 1/2-13 NYLON LOCK	F05010-8	4*
5	POINTER, MULTIHEAD BLADE HEIGHT	S22636	1*
6	DECAL, MULTIHEAD HEIGHT SCALE (INCH)	S22300	1*
	DECAL, MULTIHEAD HEIGHT SCALE (METRIC)	S22301	1*
7	BOLT, #10-24 X 5/8" HEX HEAD	F05004-18	1*
8	PAD, UP/DOWN DELRIN	M04096	4*
9	BOLT, 5/16-18 X 3/4" HEX HEAD	F05006-5	8*
10	NUT, 5/16-18 HEX NYLON LOCK	F05010-58	8*

11	PAD, UP/DOWN ADJUSTABLE NYLON	S22561	6*	
12	PAD, NYLON BACKING	042432	6*	
13	SCREW, 5/8-18 X 1 1/4" SOCKET HEAD FLAT POINT SET	F05009-27	6*	
14	NUT, 5/8-18 HEX JAM	F05010-11	6*	
15	NUT, 1/2-13 HEX JAM	F05010-31	28	
16	SCREW, 1/2-13 X 1 1/2" SOCKET HEAD FLAT POINT SET	F05008-31	2*	

2

Saw Head Parts

Motor Assembly E20, E25

2.4 Motor Assembly E20, E25

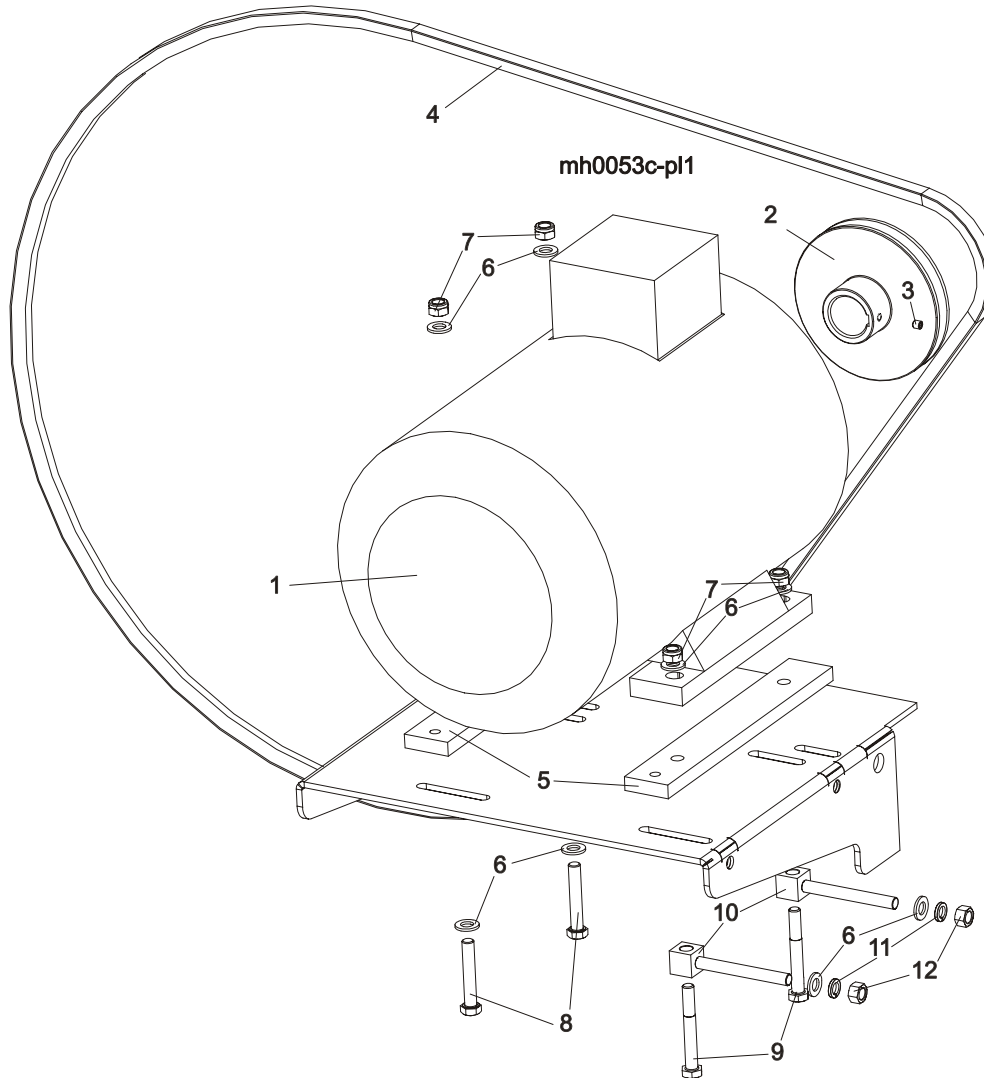

REF	DESCRIPTION (◆ Indicates Parts Available In Assemblies Only)	PART #	QTY. (* /head)
1	MOTOR, ELECTRIC E20 Sg160M2B-HM (380-420v)	087929	1*
	MOTOR, ELECTRIC E20 Sg160M2B-HM (230V)	087929-2	1*
	MOTOR, ELECTRIC E25 18.5 KW/25HP EURO (380-420 V)	085519	1*
	MOTOR, ELECTRIC E25 18.5 KW/25HP EURO (230V)	085519-2	1*
	MOTOR, ELECTRIC E25 18.5 KW/25HP EURO (400-460V)	085519-UL	1*
2	PULLEY E20, E25 MULTIHEAD	094330-1	1*
3	SCREW, M8X8-33H HEX SOCKET SET FLAT POINT	F81014-1	1*
4	BELT 5Vx1230, MULTIHEAD 50 CYCLE DRIVE	033302	1*
5	BASE FOR E20, E25 ELECTRIC MOTOR MH1000-PAINTED	504561-1	2*
6	WASHER, M12 , FLAT, ZINC	F81056-1	8*

7	NUT,M12-8 ,HEX,NYLON,ZINC,LOCK	F81034-2	4*	
8	BOLT M12x70 8.8 HEX HEAD ZINC	F81004-39	2*	
9	BOLT,M12X90-8.8 HEX HEAD ZINC	F81004-2	2*	
10	BELT TENSIONER HR1000-ZINK	504557-1	2*	
11	WASHER, M12 SPLIT LOCK ZINC	F81056-2	2*	
12	NUT, M12, HEXAGON,GRADE 5.8,ZINC	F81034-1	2*	

2

Saw Head Parts Motor Assembly E15

2.5 Motor Assembly E15

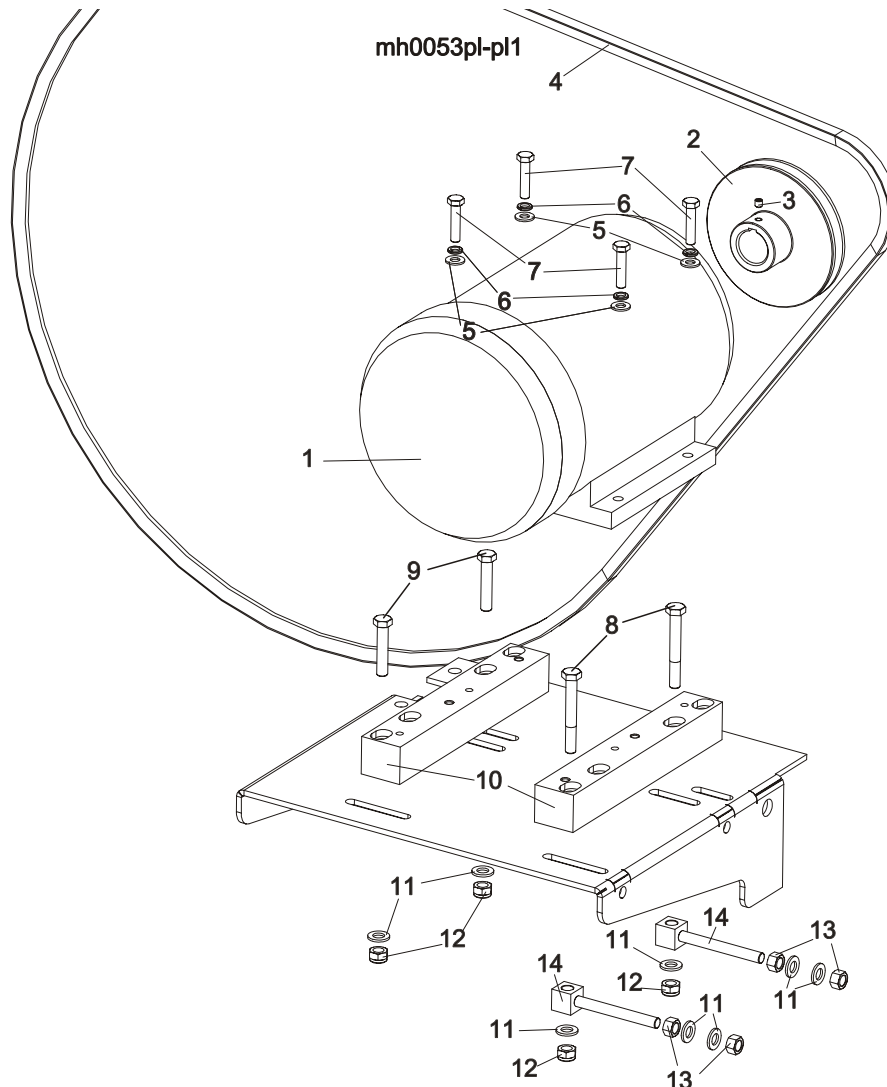

REF	DESCRIPTION (◆ Indicates Parts Available In Assemblies Only)	PART #	QTY. (* /head)
1	MOTOR, ELECTRIC E15 11kW PSg-132 S2 - HM- (380-420V)	089049	1*
	MOTOR, ELECTRIC E15 11kW PSg132S -2PC HM (230V)	089049-2	1*
2	PULLEY E15 MULTIHEAD-PAINTED	094505-1	1*
3	SCREW, M8X8-33H HEX SOCKET SET FLAT POINT	F81014-1	1*
4	BELT 5Vx1230, MULTIHEAD 50 CYCLE DRIVE	033302	1*
5	WASHER, 10.5 FLAT ZINC	F81055-1	4*
6	WASHER,10.2 SPLIT LOCK ZINC	F81055-2	4*
7	BOLT, M10X45MM,HEX HEAD,FULL THRD,ZINC	F81003-3	4*
8	BOLT,M12X90-8.8 HEX HEAD ZINC	F81004-2	2*
9	BOLT, M12X60MM, HEX HEAD GR 8.8	F81004-5	2*

10	BASE FOR ELECTRIC MOTOR E15 MH1000-PAINTED	504563-1	1*	
11	WASHER, M12 , FLAT, ZINC	F81056-1	8*	
12	NUT,M12-8 ,HEX,NYLON,ZINC,LOCK	F81034-2	4*	
13	NUT, M12, HEXAGON,GRADE 5.8,ZINC	F81034-1	2*	
14	BELT TENSIONER HR1000-ZINK	504557-1	2*	

2 Saw Head Parts
Blade Guide Roller Guard

2.6 Blade Guide Roller Guard

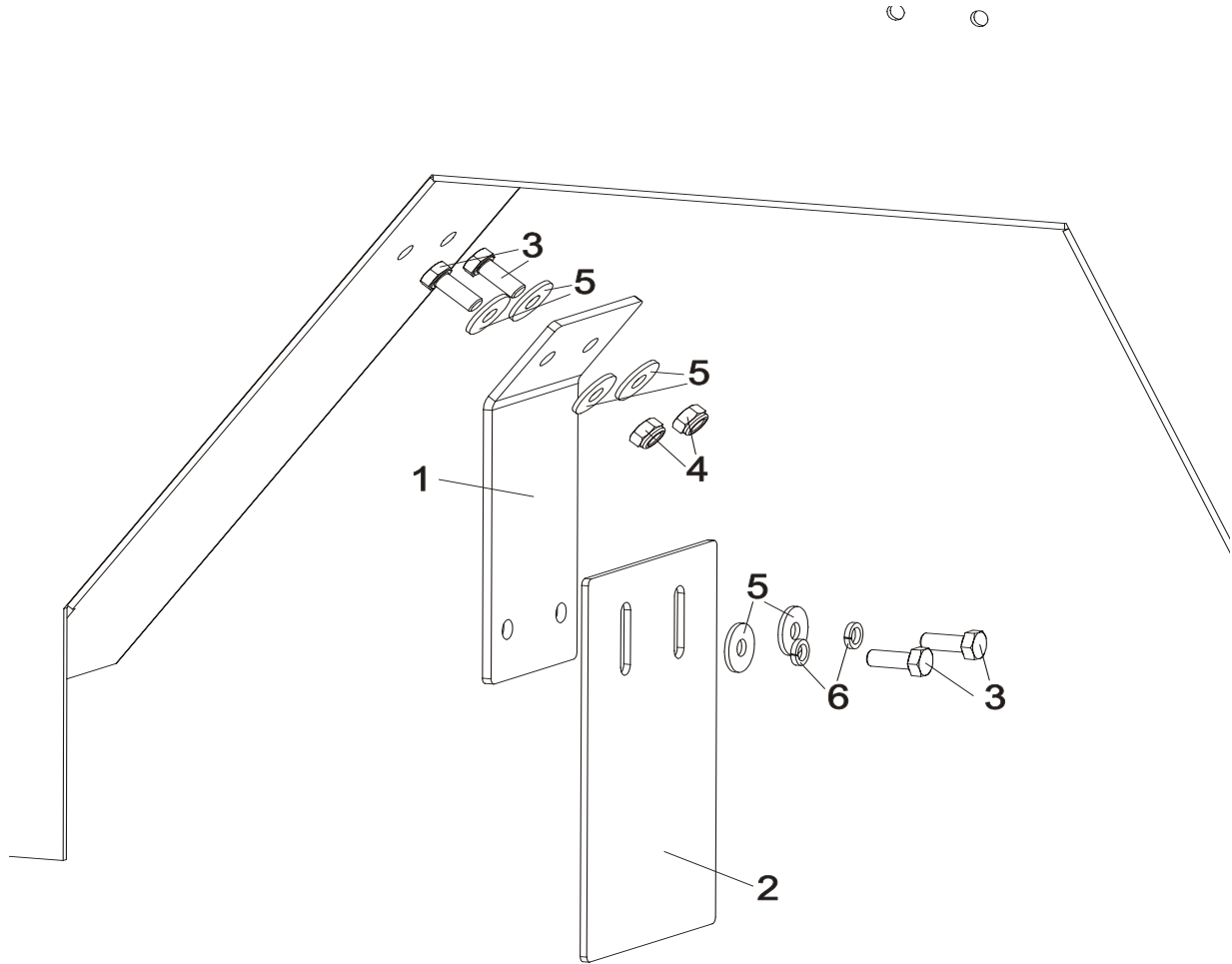

mh0054pl-pl1

REF.	DESCRIPTION (◆ Indicates Parts Available In Assemblies Only)	PART #	QTY. (*/head)
	GUARD, BLADE GUIDE ROLLER - COMPLETE	504473	1*
1	BRACKET, BLADE GUIDE ROLLER GUARD PTD	504474-1	1
2	GUARD, BLADE GUIDE ROLLER PTD	504476-1	1
3	BOLT, M8x20-8.8-B HEX HEAD FULL THREAD ZINC	F81002-4	4
4	NUT, M8-8-B HEX NYLON LOCK ZINC	F81032-2	2
5	WASHER, 8.5 FLAT ZINC	F81054-11	6
6	WASHER, 8.2 SPLIT LOCK ZINC	F81054-4	2

2.7 Inner Blade Guide Assembly

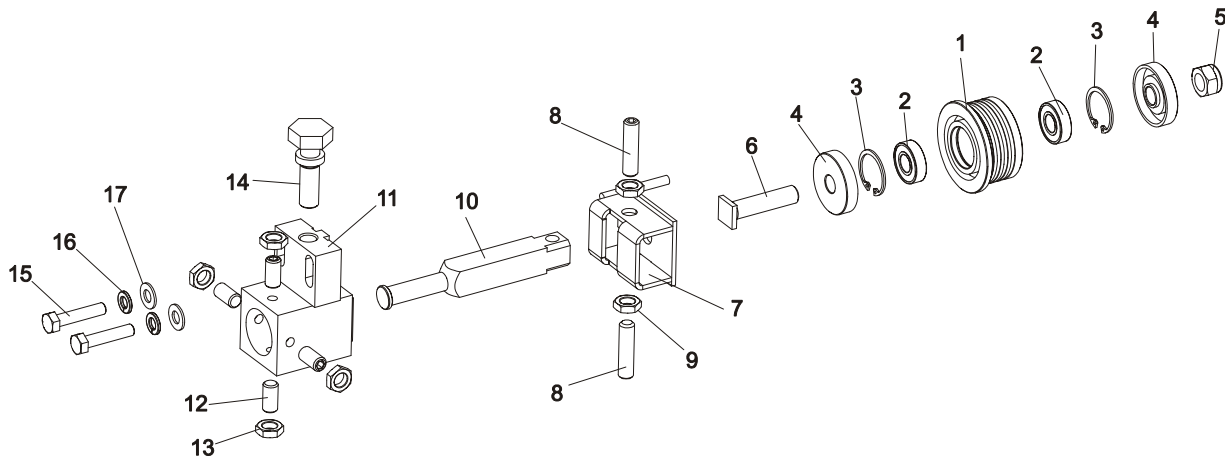

REF	DESCRIPTION (◆ Indicates Parts Available In Assemblies Only)	PART #	QTY. (*head)
	BLADE GUIDE ASSEMBLY, DRIVE SIDE	503611	1
	ROLLER ASSY, BLADE GUIDE	087887	1
1	ROLLER, BLADE GUIDE NARROW	087889	1
2	BEARING 6001 2RSR (FAG,SKF)	087893	2
3	RING, 1 1/8" INTERIOR RETAINING	F81090-9	2
4	WASHER, ZINC-PLATED SPACER	087891	2
5	NUT, M12-8 HEX NYLON ZINC LOCK	F81034-2	1
6	BOLT, BLADE GUIDE MOUNTING	087763	1
7	BRACKET WLDMT, BLADE GUIDE PTD	094679-1	1
8	SCREW, M10x1x40 DIN913 STAINLESS STEEL S	F81015-2	2
9	NUT, M10x1 DIN439 THIN	F81033-10	2
10	SHAFT, BLADE GUIDE MOUNT, ZINK PLATED	503587-1	1
11	BRACKET WELDMENT, DRIVE SIDE	503589-1	1
12	SCREW,M10x1x20 DIN913 STAINLESS STEEL SE	F81015-1	4
13	NUT, M10x1 DIN439 THIN	F81033-10	4
14	BOLT, ADJUSTING ZINC-PLATED	089502-1	1
15	BOLT, 5/16-18X1 1/2 HH GR5 FT	F81002-48	2
16	WASHER 8,2 FE/ZN9	F81054-4	2
17	WASHER, 8.4 FLAT ZINC	F81054-1	2

2 Saw Head Parts

Outer Blade Guide Assembly

2.8 Outer Blade Guide Assembly

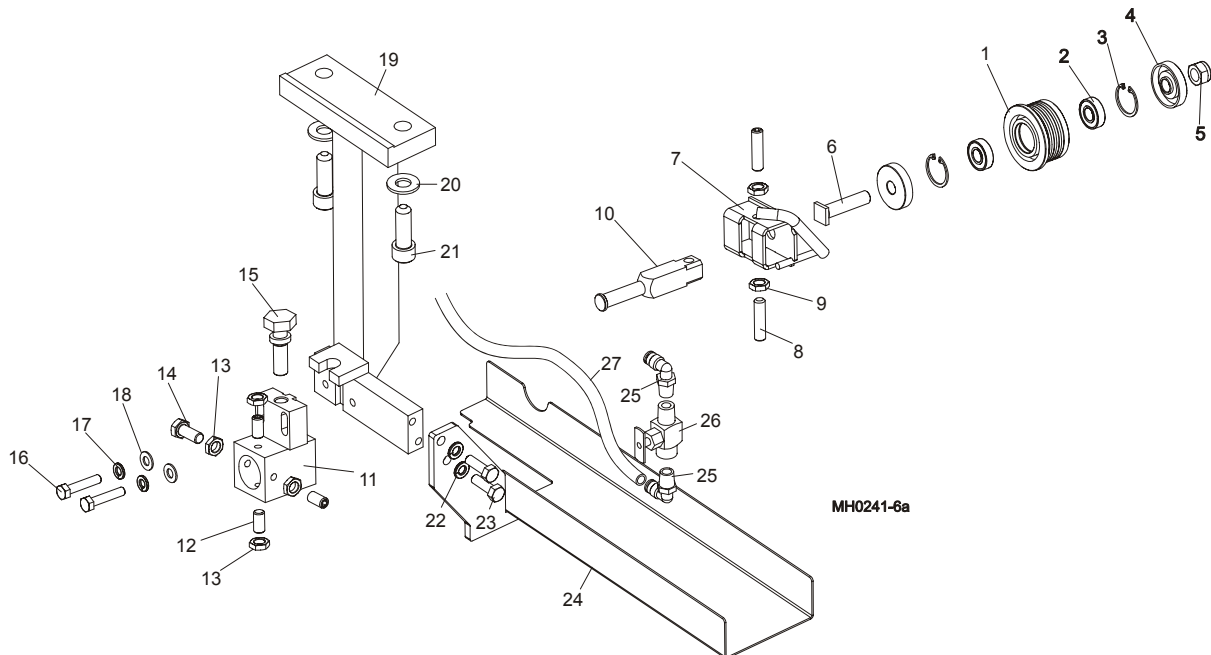

REF	DESCRIPTION (◆ Indicates Parts Available In Assemblies Only)	PART #	QTY. (* /head)
	BLADE GUIDE ASSEMBLY, DRIVE SIDE	503610	1
	ROLLER ASSY, BLADE GUIDE	087887	1
1	ROLLER, BLADE GUIDE NARROW	087889	1
2	BEARING 6001 2RSR (FAG,SKF)	087893	2
3	RING, 1 1/8" INTERIOR RETAINING	F81090-9	2
4	WASHER, ZINC-PLATED SPACER	087891	2
5	NUT, M12-8 HEX NYLON ZINC LOCK	F81034-2	1
6	BOLT, BLADE GUIDE MOUNTING	087763	1
7	BRACKET WLDMT, IDLE SIDE BLADE GUIDE PTD	094681-1	1
8	SCREW, M10x1x40 DIN913 STAINLESS STEEL S	F81015-2	2
9	NUT, M10x1 DIN439 THIN	F81033-10	2
10	WSPORNIK ROLKI KOMPLETNEJ - CYNKOW.	503588	1
11	PROWADNICA PIONOWA MULIHEAD-SP/CYNKOWANA	503589-1	1
12	SCREW, M10x1x20 DIN913 STAINLESS STEEL SE	F81015-1	3
13	NUT, M10x1 DIN439 THIN	F81033-10	4
14	BOLT, M10x1x25 DIN 933	F81003-28	1
15	BOLT, ADJUSTING ZINC-PLATED	089502-1	1
16	SRUBA 5/16" X 1 1/4" DIN-933 8.8 18 UNC	F81002-49	2
17	WASHER 8,2 FE/ZN9	F81054-4	2
18	WASHER, 8.4 FLAT ZINC	F81054-1	2
19	ARM WELDMENT, HR1000 BLADE GUIDE	007689	1*

Saw Head Parts
Outer Blade Guide Assembly 2

20	WASHER, 1/2" SAE FLAT	F05011-2	2*	
21	BOLT, 1/2-20 X 1 1/2" SOCKET HEAD	F05008-44	2*	
22	WASHER, 5/16" SPLIT LOCK	F05011-13	2*	
23	BOLT, 5/16-18 X 1" HEX HEAD GRADE 5	F05006-27	2*	
24	GUARD, HR1000 OUTER BLADE GUIDE	007692	1*	
25	FITTING, 1/4" NPT X 1/4" TUBE 90°	P21519	2	
26	VALVE, WATER SHUTOFF	P05680	1*	
27	HOSE, 1/4" O.D. PLASTIC	R01869	As Req'd	

2 Saw Head Parts

Up/Down Assembly

2.9 Up/Down Assembly

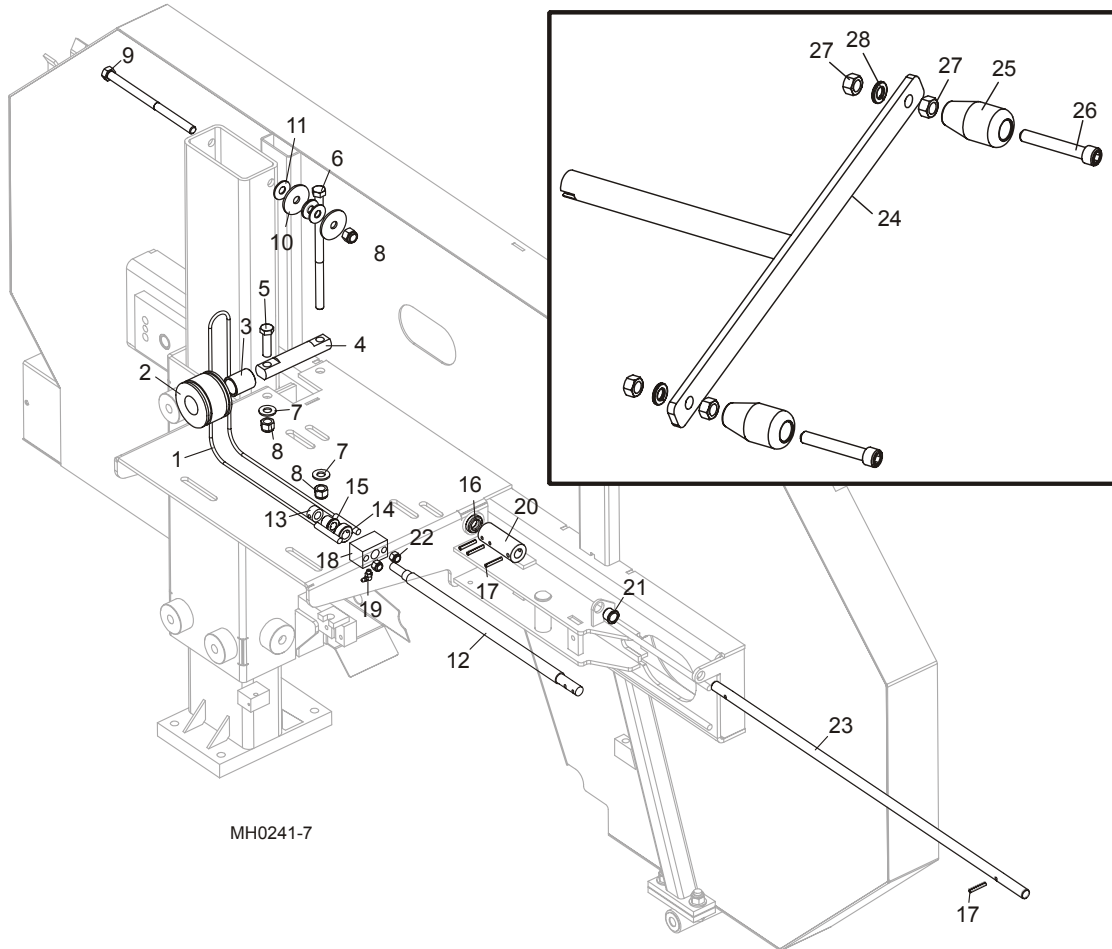

REF	DESCRIPTION (◆ Indicates Parts Available In Assemblies Only)	PART #	QTY. (* /head)
1	CABLE, MULTIHEAD UP/DOWN	S22307	1
2	PULLEY, 2-GROOVE UP/DOWN CABLE	S22205	1
3	BUSHING, 1" X 1 1/4" X 1 1/2" BRONZE	P05041	1
4	PIN, CABLE PULLEY MOUNT	007672	1
5	BOLT, 1/2-13 X 1 3/4" HEX HEAD GRADE 5	F05008-88	1
6	BOLT, 1/2-13 X 8 1/2" HEX HEAD GRADE 5	F05008-147	1
7	WASHER, 1/2" SAE FLAT	F05011-2	2
8	NUT, 1/2-13 HEX NYLON LOCK	F05010-8	3
9	BOLT, 1/2-13 X 8" HEX HEAD GRADE 5	F05008-69	1
10	WASHER, 1/2" I.D. X 2" O.D. FENDER	F05011-38	2
11	WASHER, 7/16" STANDARD FLAT	F05011-35	4
12	ROD, UP/DOWN THREADED	S22208	1
13	COLLAR, 1/2" I.D. SHAFT	014820	1

14	BUSHING, 1/2" X 3/4" FLANGED BRONZE	P22317	1	
15	COLLAR, 5/8" I.D. SHAF6	P05035	1	
16	BEARING, 5/8" THRUST	P04214	1	
17	PIN, 3/16" X 1 1/4" ROLL	F05012-16	4	
18	BLOCK, UP/DOWN THREADED	S22209	1	
19	FITTING, 1/4-28 90° GREASE	P04108	1	
20	COUPLING, UP/DOWN CRANK	S22476	1	
21	BUSHING, .635 ID X .750 OD NYLON FLANGED	P22478	2	
22	NUT, 3/8-16 HEX NYLON LOCK	F05010-10	2	
23	SHAFT, UP/DOWN ADJUSTMENT	007705	1	
	CRANK HANDLE ASSEMBLY	033251	1	
24	Crank Weldment, Toe Board Painted	033253	1	
25	Handle, Power Feed & Up/Down	S08291-W	2	
26	Screw, 3.8-16 x 2 1/2" Socket Head Cap	F05007-24	2	
27	Nut, 3/8-16 Free Hex	F05010-1	4	
28	Washer, 3/8" Split Lock	F05011-4	2	

2 Saw Head Parts
Blade Wheel Assembly (Drive Side)

2.10 Blade Wheel Assembly (Drive Side)

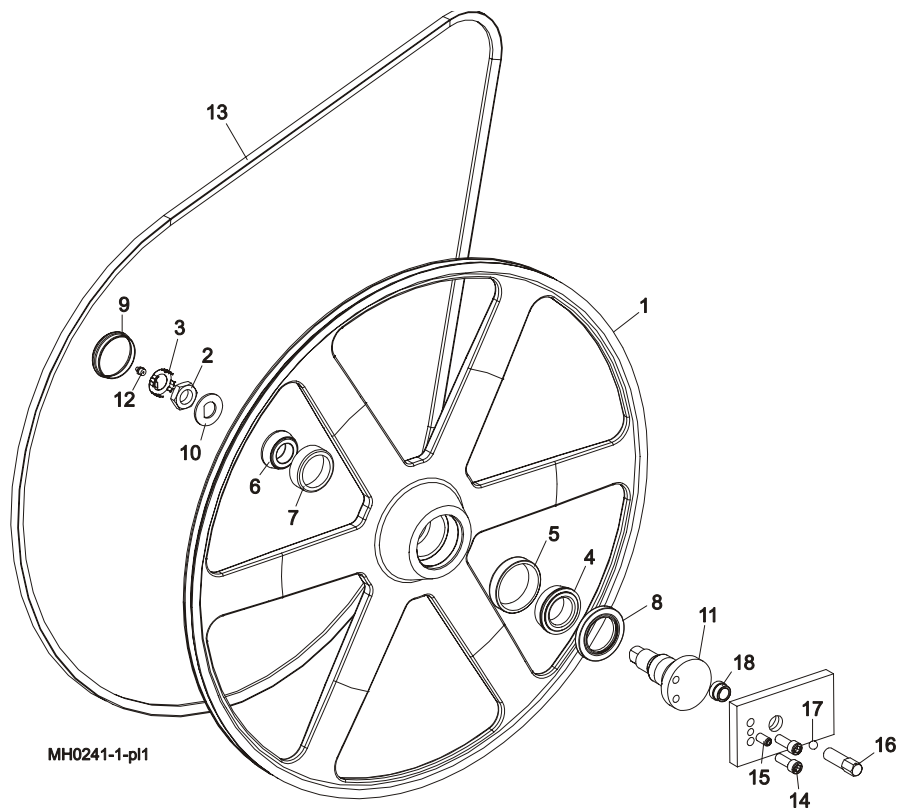

MH0241-1-pl1

REF	DESCRIPTION (◆ Indicates Parts Available In Assemblies Only)	PART #	QTY. (* /head)	
	WHEEL ASSEMBLY, 34" HR1000 BLADE	006553	1*	
1	Wheel, 34" Cast Blade	006544	1	◆
	Nut Assembly, Spindle w/Retainer	007656	1	
2	Nut, 1-14 Spindle	007654	1	
3	Retainer, Spindle Nut	007655	1	
4	Bearing, Inner	045208	1	
5	Race, Inner Bearing	045209	1	
6	Bearing, Outer	045210	1	
7	Race, Outer Bearing	045211	1	
8	Seal, Blade Wheel Bearing	045212	1	
9	Cap, Hub Dust	033238	1	
10	Washer, Spindle 'D'	045214	1	
11	Shaft, HR1000 Spindle	006545	1	
12	Fitting, 1/8" NPT Straight Grease	P108	1	
13	BELT 5Vx1230, MULTIHEAD 50 CYCLE DRIVE	033302	1	
14	SCREW, 1/2-20 X 1 1/2" SOCKET HEAD CAP	F05008-44	2*	
15	SCREW, 1/2-13 X 1" OVAL POINT SET NYLON LOCK	F05008-9	1*	

Saw Head Parts
Blade Wheel Assembly (Drive Side)

2

	SCREW ASSEMBLY, BLADE WHEEL TILT	007652	1*	
16	Screw, Cant Adjustment	007651	1	◆
17	Ball, 1/2" Diameter Detent	P02720	1	
18	BUSHING, 3/4-32 THREADED	007627 ¹	1*	

¹ Bushing is welded to C-frame block. Factory removal and installation recommended.

2 Saw Head Parts

Blade Wheel Assembly (Idle Side)

2.11 Blade Wheel Assembly (Idle Side)

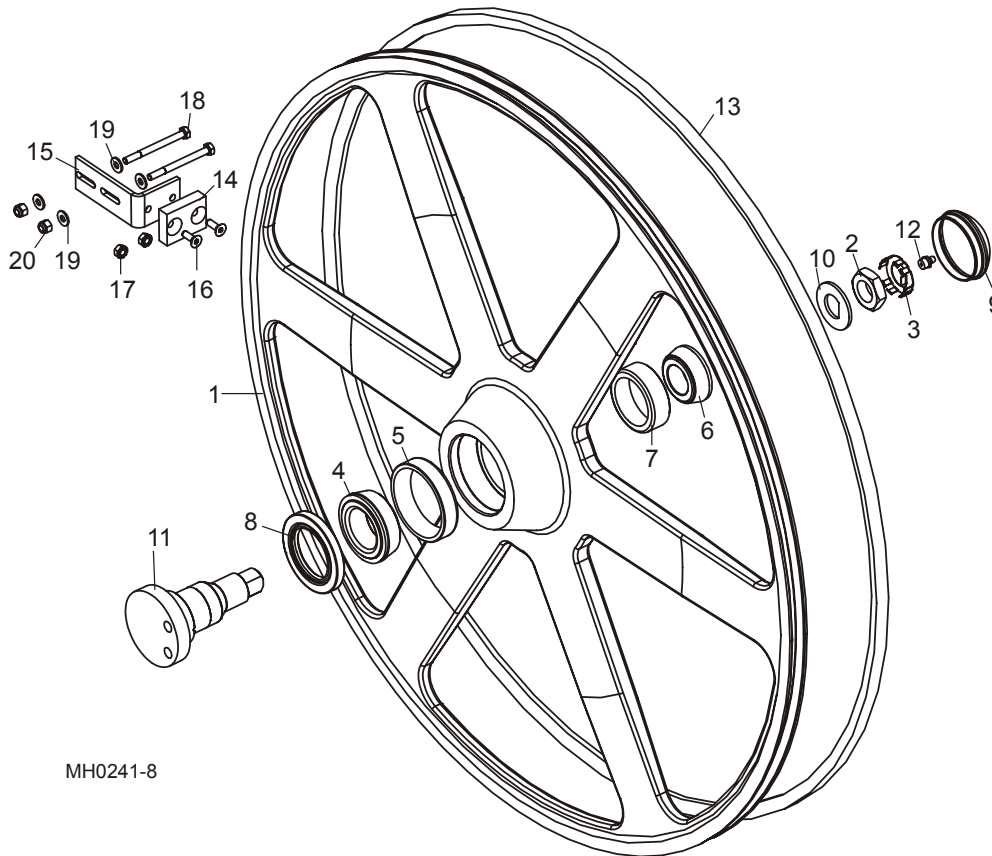

REF	DESCRIPTION (◆ Indicates Parts Available In Assemblies Only)	PART #	QTY. (* /head)	
	WHEEL ASSEMBLY, 34" HR1000 BLADE	006553	1*	
1	Wheel, 34" Cast Blade	006544	1	◆
	Nut Assembly, Spindle w/Retainer	007656	1	
2	Nut, 1-14 Spindle	007654	1	
3	Retainer, Spindle Nut	007655	1	
4	Bearing, Inner	045208	1	
5	Race, Inner Bearing	045209	1	
6	Bearing, Outer	045210	1	
7	Race, Outer Bearing	045211	1	
8	Seal, Blade Wheel Bearing	045212	1	
9	Cap, Hub Dust	033238	1	
10	Washer, Spindle 'D'	045214	1	
11	Shaft, HR1000 Spindle	006545	1	
12	Fitting, 1/8" NPT Straight Grease	P108	1	
13	BELT, 5VX1080	033391	1	

Saw Head Parts
Blade Wheel Assembly (Idle Side)

2

	BRAKE PAD ASSEMBLY	A22901	1*	◆
14	Pad, Wheel Brake	S22200	1	
15	Bracket, Brake Pad Mount	S22201	1	
16	Screw, 1/4-20 x 3/4" Flat Socket Head	F05005-70	2	
17	Nut, 1/4-20 Hex Self-Locking	F05010-9	2	
18	BOLT, 1/4-20 X 3" HEX HEAD GRADE 5	F05005-127	2	
19	WASHER, 1/4" SAE FLAT	F05011-11	4	
20	NUT, 1/4-20 HEX NYLON LOCK	F05010-69	2	

2.12 Blade Housing Cover

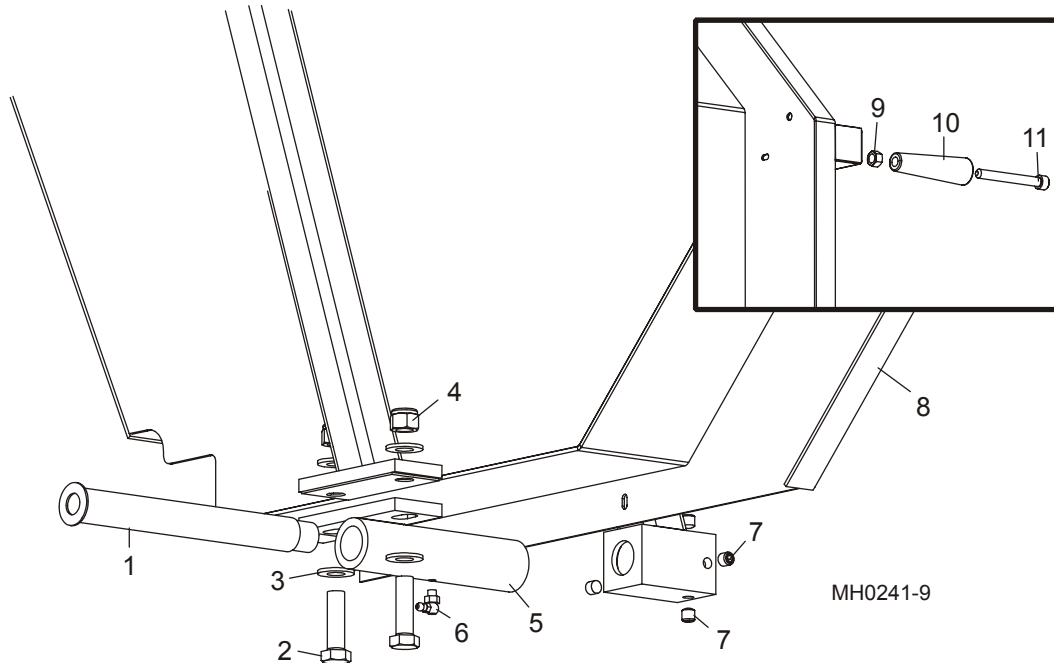

REF	DESCRIPTION (◆ Indicates Parts Available In Assemblies Only)	PART #	QTY. (*/head)
1	PIN WELDMENT, COVER PIVOT	W22064	1
2	BOLT, 1/2-13 X 1 3/4" HEX HEAD GRADE 5	F05008-88	2
3	WASHER, 1/2" SAE FLAT	F05011-2	4
4	NUT, 1/2-13 HEX NYLON LOCK	F05010-8	2
5	TUBE WELDMENT, COVER PIVOT	W22623	1
6	FITTING, 1/4-28 GREASE 90°	P04108	1
7	SCREW, 3/8-16 X 3/8" SOCKET HEAD OVAL POINT SET	F05007-13	4
8	COVER WELDMENT, HR1000 BLADE HOUSING	007698	1
9	NUT, 3/8-16 HEX	F05010-1	1
10	KNOB, COVER PIVOT	060170	1
11	BOLT, 3/8-16 X 3 1/2" SOCKET HEAD	F05007-111	1

2.13 Sawdust Chute

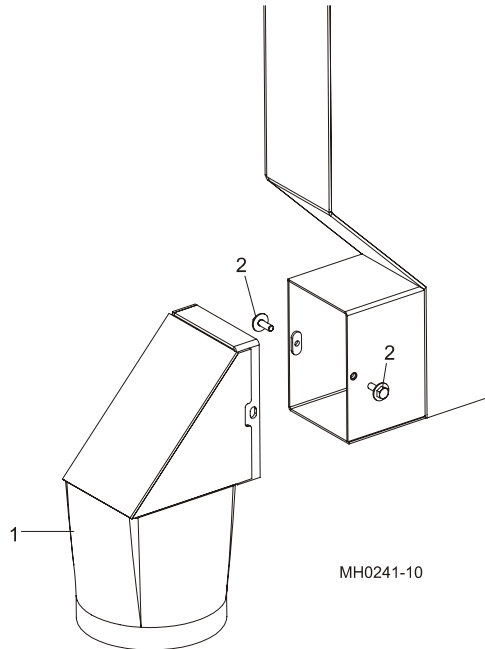

REF.	DESCRIPTION (◆ Indicates Parts Available In Assemblies Only)	PART #	QTY. (*head)	
1	CHUTE WELDMENT, SAWDUST EXTENSION	W22556	1	
2	WASHER, 1/4" SAE FLAT	F05005-134	2	

2.14 Warning Decals

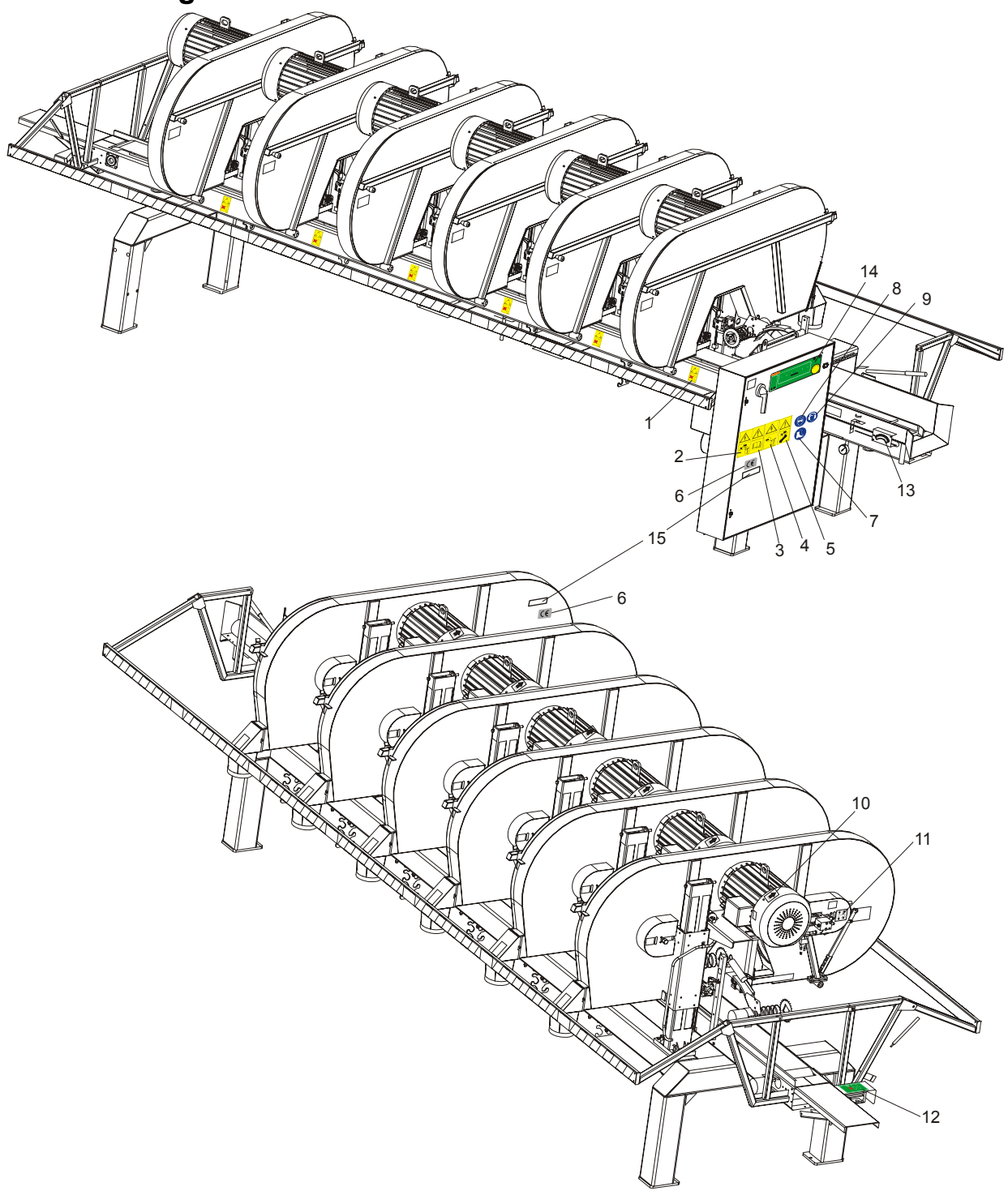

REF.	DESCRIPTION (◆ Indicates Parts Available In Assemblies Only)	PART #	QTY. (*/head)
	DIAGRAM, WARNING DECALS LAYOUT	502041	1
1	DECAL, SPROCKET CAUTION (PICTOGRAM)	099540	6
2	DECAL, REMOVE THE PLUG BEFORE OPENING THE BOX (PICTOGRAM)	096319	1
3	DECAL, READ OPERATOR'S MANUAL (PICTOGRAM)	096317	1
4	DECAL, HAZARDOUS VOLTAGE INSIDE THE ELECTRIC BOX (PICTOGRAM)	096316	1
5	DECAL, DISCONNECT POWER SUPPLY BEFORE SERVICING (PICTOGRAM)	098177	1
6	DECAL, CE CERTIFIED SAWMILL - SMALL	P85070	2
7	DECAL, ALWAYS USE SAFETY BOOTS	501465	1
8	DECAL, EYE PROTECTION WARNING (PICTOGRAM)	S12004G	1
9	DECAL, EAR PROTECTION WARNING (PICTOGRAM)	S12005G	1
10	DECAL, MOTOR REVOLUTIONS DIRECTION (PICTOGRAM)	S20097_e	6
11	DECAL, BLADE ALIGNMENT	P11789	6
12	DECAL, ADDITIONAL CONTROL BOX	502042	1
13	DECAL, FEED RATE SCALE	502043	1
14	DECAL, HR1000 CONTROL PANEL	090928	1
15	DECAL, SERIAL NUMBER		

SECTION 3 FEED TRACK/FRAME PARTS

3.1 Hydraulic Blade Tensioner Assembly

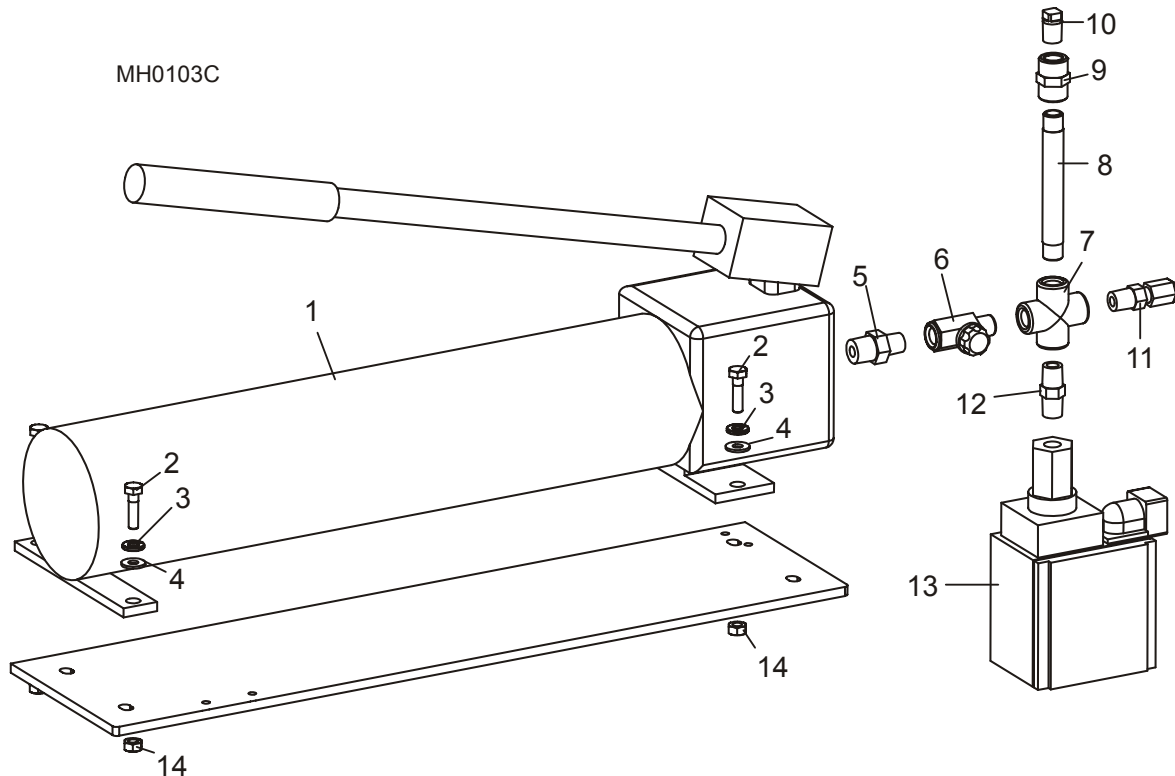

REF	DESCRIPTION (◆ Indicates Parts Available In Assemblies Only)	PART #	QTY.
1	PUMP, HYDRAULIC 2-STAGE HAND (1-4 HEADS)	P22302	1
	PUMP, HYDRAULIC 2-STAGE HAND (5-6 HEADS)	P22310	1
2	BOLT, 1/4-20 X 1" HEX HEAD	F05005-101	4
3	WASHER, 1/4" SPLIT LOCK	F05011-14	4
4	WASHER, 1/4" SAE FLAT	F05011-11	4
5	FITTING, 3/8" NPT - 1/4" NPT STRAIGHT	P05381	1
6	VALVE, HYDRAULIC SHUTOFF	P22314	1
7	FITTING, 1/4" NPT CROSS	P22311	1
8	FITTING, 1/4" NPT X 4" NIPPLE	016428	1
9	FITTING, 1/4" NPT COUPLING	P03420	1
10	Plug, 1/4NPT Pipe	P05498	1
11	FITTING, 1/4" NPT X 1/4" TUBE	P22518	1
12	FITTING, 1/4" NPT STRAIGHT	P05389	1
13	SWITCH, HYDRAULIC PRESSURE SHUT-OFF	E22726 ¹	1
14	NUT, 1/4-20 HEX	F05010-63	4

¹ Switch E22726 changed by manufacturer 4/11. New switch has straight wire connection. Replace fitting on connecting harness with swivel connector 051750.

3.2 Perimeter Fence Assembly

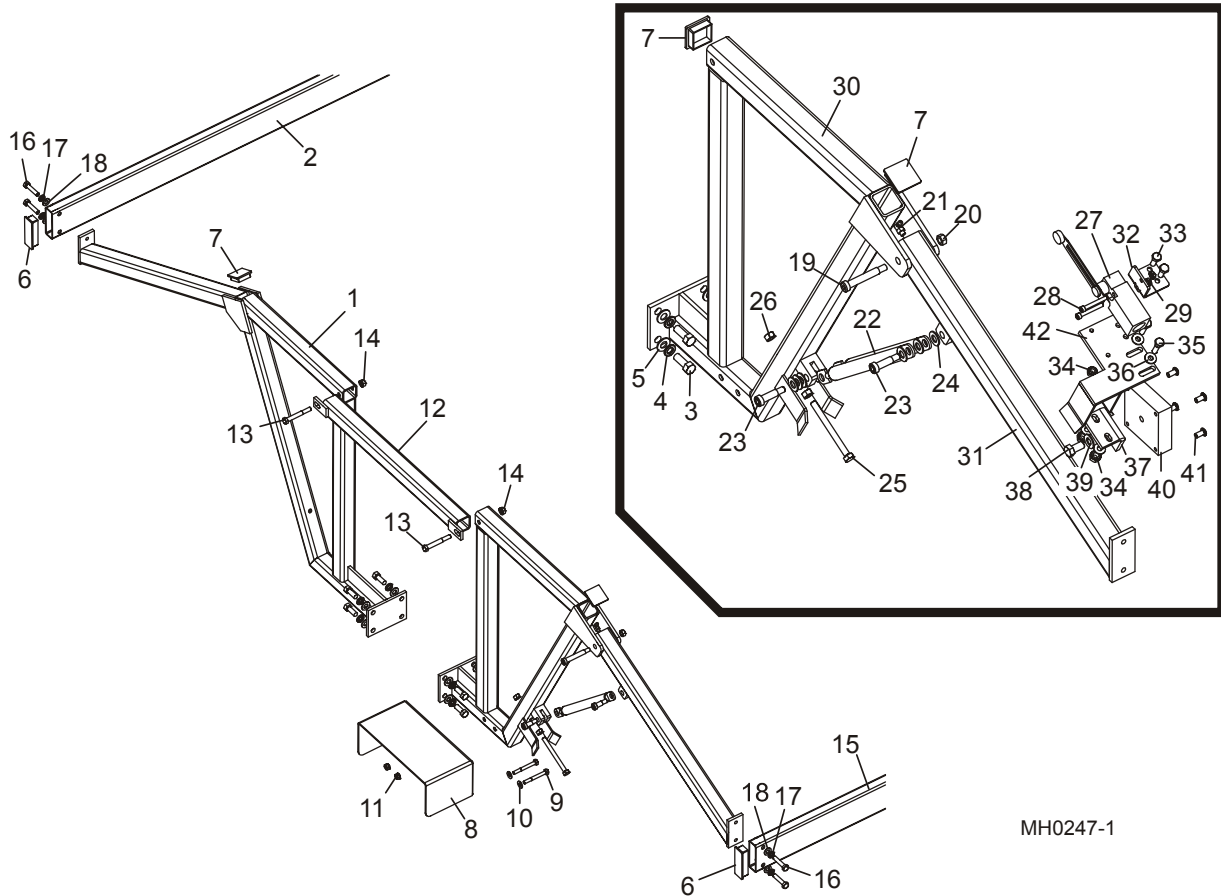

MH0247-1

REF	DESCRIPTION (◆ Indicates Parts Available In Assemblies Only)	PART #	QTY.
1	BRACKET, FIXED PERIMETER FENCE MOUNT	W22168	2
2	TUBE, FIXED PERIMETER FENCE	S22167-X*	1
3	BOLT, 3/8-16 X 1" HEX HEAD	F05007-7	16
4	WASHER, 3/8" SPLIT LOCK	F05011-4	16
5	WASHER, 3/8" SAE FLAT	F05011-3	16
6	PLUG, 1" X 3" PLASTIC	P22522	4
7	PLUG, 1 1/2" SQUARE PLASTIC	P22321	5
8	GUARD WELDMENT, REMOTE CONTROL SWITCH	W22081	1
9	BOLT, 1/4-20 X 2 1/4" HEX HEAD	F05005-72	2
10	WASHER, 1/4" SAE FLAT	F05011-11	2
11	NUT, 1/4-20 HEX SELF-LOCKING	F05010-9	2
12	TUBE, PERIMETER FENCE CROSS	W22185	1
13	BOLT, 5/16-18 X 2 1/2" HEX HEAD	F05006-10	4
14	NUT, 5/16-18 SELF-LOCKING HEX	F05010-20	4

3

Feed Track/Frame Parts

Perimeter Fence Assembly

15	TUBE, SWINGING PERIMETER FENCE	S22164-X*	1	
16	BOLT, 5/16-18 X 1 1/2" HEX HEAD FULL THREAD	F05006-2	8	
17	WASHER, 5/16" SPLIT LOCK	F05011-13	8	
18	WASHER, 5/16" SAE FLAT	F05011-17	8	
19	BOLT, 3/8" X 2" SHOULDER (5/16-18 THREAD)	F05006-26	2	
20	NUT, 5/16-18 LOCK	F05010-6	2	
21	FITTING, 1/4-28 90°GREASE	P04108	2	
22	PISTON, PERIMETER FENCE GAS	P22309	3**	
23	BOLT, 3/8" X 5/8" SHOULDER (5/16-18 THREAD)	F05007-79 ¹	4	
	BOLT, 3/8" X 1" X 5/16-18 SHOULDER	F05006-25 ¹	2	
24	WASHER, 3/8" SAE FLAT	F05011-3 ²	6	
25	BOLT, 5/16-18 X 3 1/2" HEX HEAD FULL THREAD	F05006-3	2	
26	NUT, 5/16-18 HEX	F05010-17	4	
27	SWITCH, PERIMETER FENCE LIMIT	039378	1	
28	BOLT, #10-24 X 1 1/2" SOCKET HEAD	F05004-51	2	
29	NUT, #10-24 SELF-LOCKING HEX	F05010-14	2	
30	BRACKET, SWINGING PERIMETER FENCE MOUNT	W22441	2	
31	ARM, SWINGING PERIMETER FENCE	W22179	2	
32	BRACKET, PERIMETER SWITCH MOUNT	065580	1	
33	BOLT, 1/4-20 X 3/4" HEX HEAD FULL THREAD	F05005-1	2	
34	NUT, 1/4-20 HEX SELF LOCKING	F05010-9	4	
35	BOLT, 1/4-20 X 1" HEX HEAD GRADE 5	F05005-101	2	
36	WASHER, 1/4" SAE FLAT	F05011-11	4	
37	BRACKET, PERIMETER FENCE SWITCH "L"	S22243	1	
38	BOLT, 3/8-16 X 3/4" HEX HEAD GRADE 2	F05007-27	1	
39	WASHER, 3/8" SAE FLAT	F05011-3	1	
40	PLATE, PERIMETER FENCE SAFETY SWITCH	033398	1	
41	SCREW, 1/4-20 X 1/2" BUTTON SOCKET HEAD	F05005-59	4	
42	BRACKET, PERIMETER FENCE SAFETY SWITCH MOUNTING	W22246	1	
*X =Number Of Saw Heads				
** Three pistons supplied on 5 & 6 head models only. Other models supplied with two.				

¹ Use 5/8" long shoulder bolt F05007-79 to mount single piston. Use 1" long shoulder bolt F05006-25 to mount dual pistons supplied on 5 & 6 head models.

² For dual pistons supplied on 5 & 6 head models only.

3.3 Feed Track Assembly

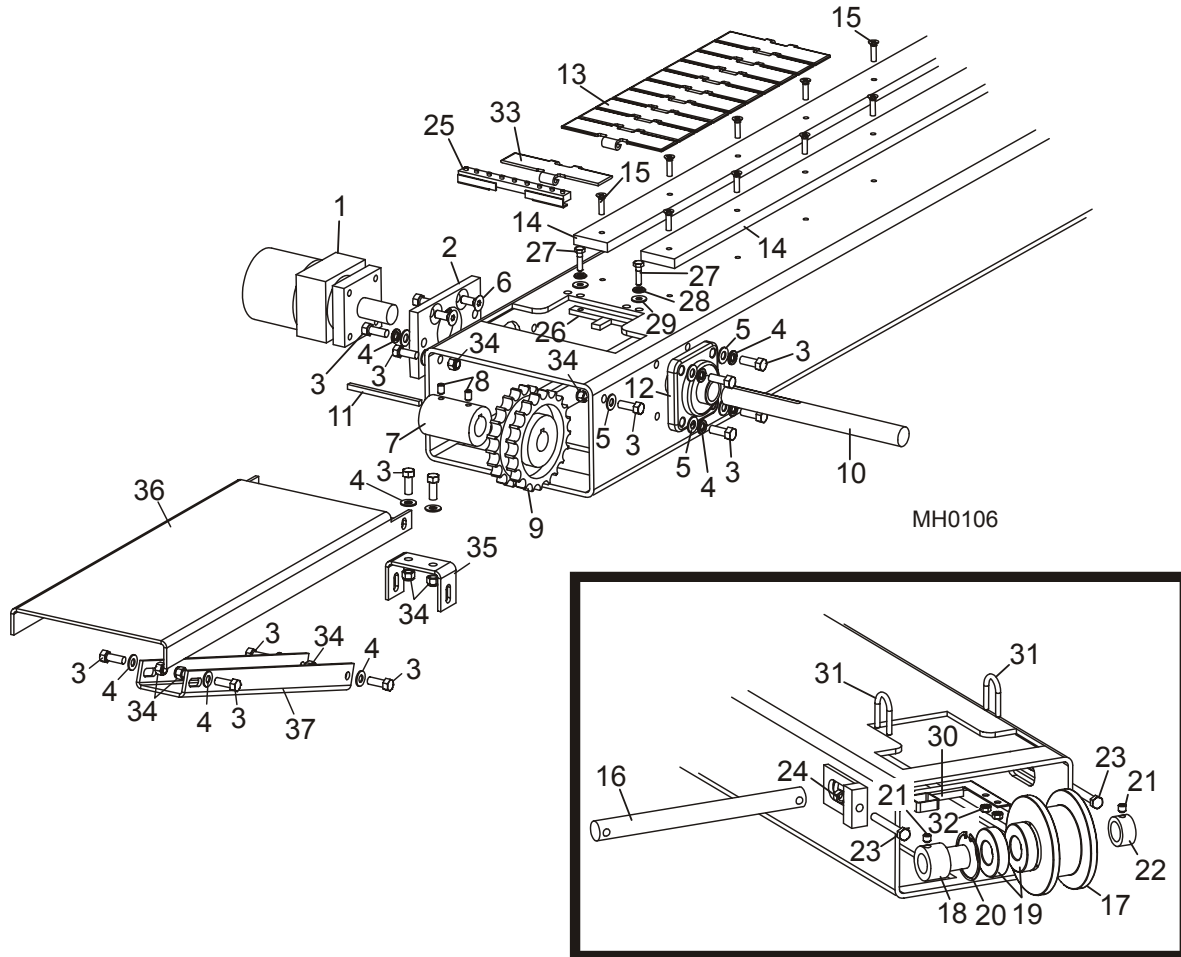

MH0106

REF	DESCRIPTION (◆ Indicates Parts Available In Assemblies Only)	PART #	QTY.	
1	MOTOR, MG10-13-10AAAB HYDRAULIC	P20206	1	
2	PLATE, FEED TRACK MOTOR MOUNT	S20173	1	
3	BOLT, 3/8-16 X 1" HEX HEAD	F05007-7	14	
4	WASHER, 3/8" SPLIT LOCK	F05011-4	6	
5	WASHER, 3/8" SAE FLAT	F05011-3	14	
6	SCREW, 3/8-16 X 1" FLAT SOCKET HEAD	F05007-64	4	
7	COUPLING, FEED TRACK MOTOR SHAFT	S20185	1	
8	SCREW, 5/16-18 X 1/2" SOCKET HEAD SET	F05006-38	2	
9	SPROCKET, 21-22T FEED TRACK DRIVE	P20202	1	
10	SHAFT, FEED TRACK DRIVE	S22428	1	
11	KEY, 1/4" SQUARE X 4.25"	S22440	1	
12	BEARING, VJC 1 FLANGED	P20201	1	
13	CHAIN, 7.5" FLAT FEED TRACK	P22427 (1 Foot)	As Req'd ¹	

3

Feed Track/Frame Parts

Feed Track Assembly

	Pin, Track Link Connecting	022424	As Req'd	
14	FEED TRACK NYLON PADS (See Section 3.4)			
15	BOLT, 1/4-20 X 3/4" HEX HEAD W/CONICAL WASHER	F05005-134	As Req'd	
16	SHAFT, FEED TRACK IDLE	S22425	1	
17	PULLEY, FEED TRACK IDLE	S20282	1	
18	BUSHING, FEED TRACK IDLE	S20286	1	
19	BEARING, 6206-2RS	P11035	2	
20	RING, 62MM INTERIOR RETAINING	F04254-12	1	
21	SCREW, 3/8-16 X 3/8" CUP POINT SET	F05007-68	2	
22	COLLAR, LOCKING	S20159-1	1	
23	BOLT, 3/8-16 X 3" HEX HEAD FULL THREAD	F05007-1	2	
24	NUT, 3/8-16 HEX	F05010-1	2	
	SAWDUST ELIMINATION KIT	A22649-12	1	
25	Rake, Feed Tube Sawdust	W22641	1	
26	Scraper, Feed Track Drive Sprocket	W22644	1	
27	Bolt, 1/4-20 x 3/4" Hex Head Full Thread	F05005-1	2	
28	Washer, 1/4" Split Lock	F05011-14	2	
29	Washer, 1/4" SAE Flat	F05011-11	2	
30	Scraper, 12" Feed Track Idle Pulley	W22652-12	1	
31	Bolt, 1/4-20 x 1 1/4" 'U'	F05005-81	2	
32	Nut, 1/4-20 Self-Locking Hex	F05010-9	4	
33	Chain, Modified 7.5" Flat Feed Track	S22426	1	
	Instruction Sheet, Sawdust Elimination Kit	A22373-440	1	
34	NUT, 3/8-16 HEX NYLON LOCK	F05010-10	8	
35	BRACKET, OFF-LOAD TABLE MOUNT	S22085	1	
36	PLATE WELDMENT, OFF-LOAD TABLE	W22438	1	
37	BRACKET, OFF-LOAD TABLE SUPPORT	S22218	1	

¹ 1 & 2 Head machines require 23' of track chain; 3 & 4 Head machines, 34'; 5 & 6 Head machines, 46'.

3.4 Feed Track Nylon Pads

Model	1/2" x 2 3/4" Nylon Pads See Qty. Below to replace entire set of track pads ¹	
	S22781 (60")	S22782 (56")
MH1D12 MH2D12	4	--
MH3D12 MH4D12	4	2
MH5D12 MH6D12	4	4

¹ All pads should be replaced in complete sets.

3 Feed Track/Frame Parts

Feed Roller Assembly (Non-Air)

3.5 Feed Roller Assembly (Non-Air)

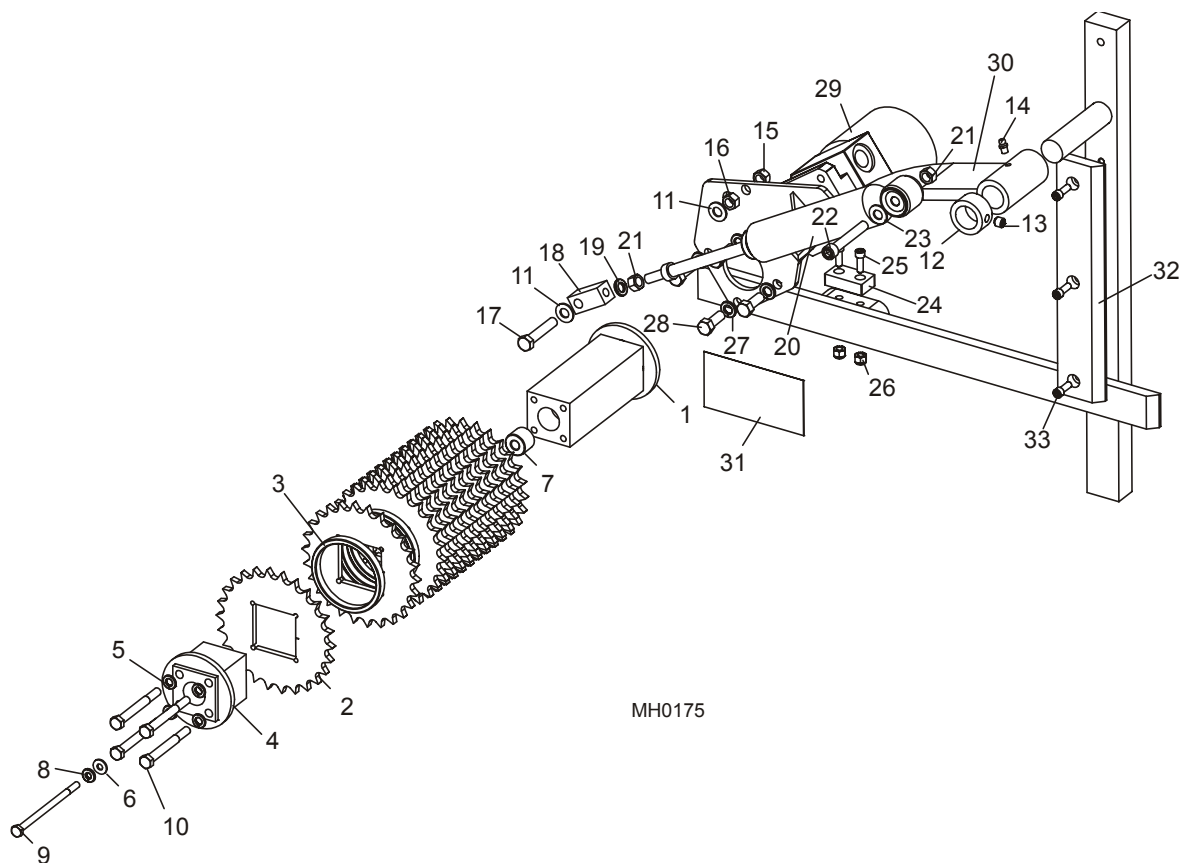

REF	DESCRIPTION (◆ Indicates Parts Available In Assemblies Only)	PART #	QTY (*/head)	
	FEED ROLLER ASSEMBLY, 12" MULTIHEAD	A22486-12	1	
1	Shaft Weldment, Feed Roller	W22485	1	◆
2	Sprocket, Feed Roller Square Shaft	S22480	13	
	Sprocket, Smooth Feed Roller Square Shaft	016530	13	
3	Ring, Sprocket Spacer	S22481	12	
4	Shaft Extension Weldment, Feed Roller	W22485-12	1	◆
5	Washer, 5/16" Split Lock	F05011-13	4	
6	Washer, 1/4" SAE Flat	F05011-11	1	
7	Spacer, Feed Roller Shaft	S22487	1	
8	Washer, 1/4" Split Lock	F05011-14	1	
9	Bolt, 1/4-20 x 4 1/2" Hex Head Grade 5	F05005-76	1	
10	Bolt, 5/16-18 x 3" Hex Head Grade 5	F05006-62	4	
	HANDLE, FEED ROLLER LIFT	S22488	2/machine	◆
11	WASHER, 3/8" SAE FLAT	F05011-3	2	
12	COLLAR, FEED ROLLER LOCKING	S20159-1	1	

Feed Track/Frame Parts

Feed Roller Assembly (Non-Air)

3

13	SCREW, 3/8-16 X 3/8" CUP POINT SET	F05007-68	1	
14	FITTING, 1/4-28 GREASE	P05060	1	
15	NUT, 3/8-16 HEX	F05010-1	1	
16	NUT, 3/8-16 HEX LOCK	F05010-25	1	
17	BOLT, 3/8-16 X 2" HEX HEAD FULL THREAD	F05007-16	1	
	SHOCK ASSEMBLY, FEED ROLLER	A22699	1	
18	Block, Feed Roller Piston Pivot	S20163	1	
19	Washer, 3/8" Split Lock	F05011-4	1	
20	SHOCK ASSY, FEED ROLLER	A22699	1	◆
21	Nut, 3/8-16 Hex	F05010-1	2	
22	Bolt, 3/8-16 X 2 1/2" Socket Head	F05007-24	1	
23	Washer, 3/8" SAE Flat	F05011-3	1	
24	BUMPER, FEED ROLLER	038898	1	
25	BOLT, 1/4-20 X 3/4" SOCKET HEAD	F05006-26	2	
26	NUT, 1/4-20 HEX NYLON LOCK	F05010-69	2	
27	WASHER, 3/8" SPLIT LOCK	F05011-4	4	
28	BOLT, 3/8-16 X 1" HEX HEAD	F05007-7	4	
29	MOTOR, MG10-13-10AAAB HYDRAULIC	P20206	1	
30	ARM, FEED ROLLER MOUNT	W22113-1	1	
31	DECAL, HAND SAFETY DANGER	S20040	1	
32	PAD, POST SLIDE	033400	1	
33	SCREW, 1/4-20 X 3/4" SOCKET HEAD	F05005-26	3	

3

Feed Track/Frame Parts Feed Roller Assembly (Non-Air)

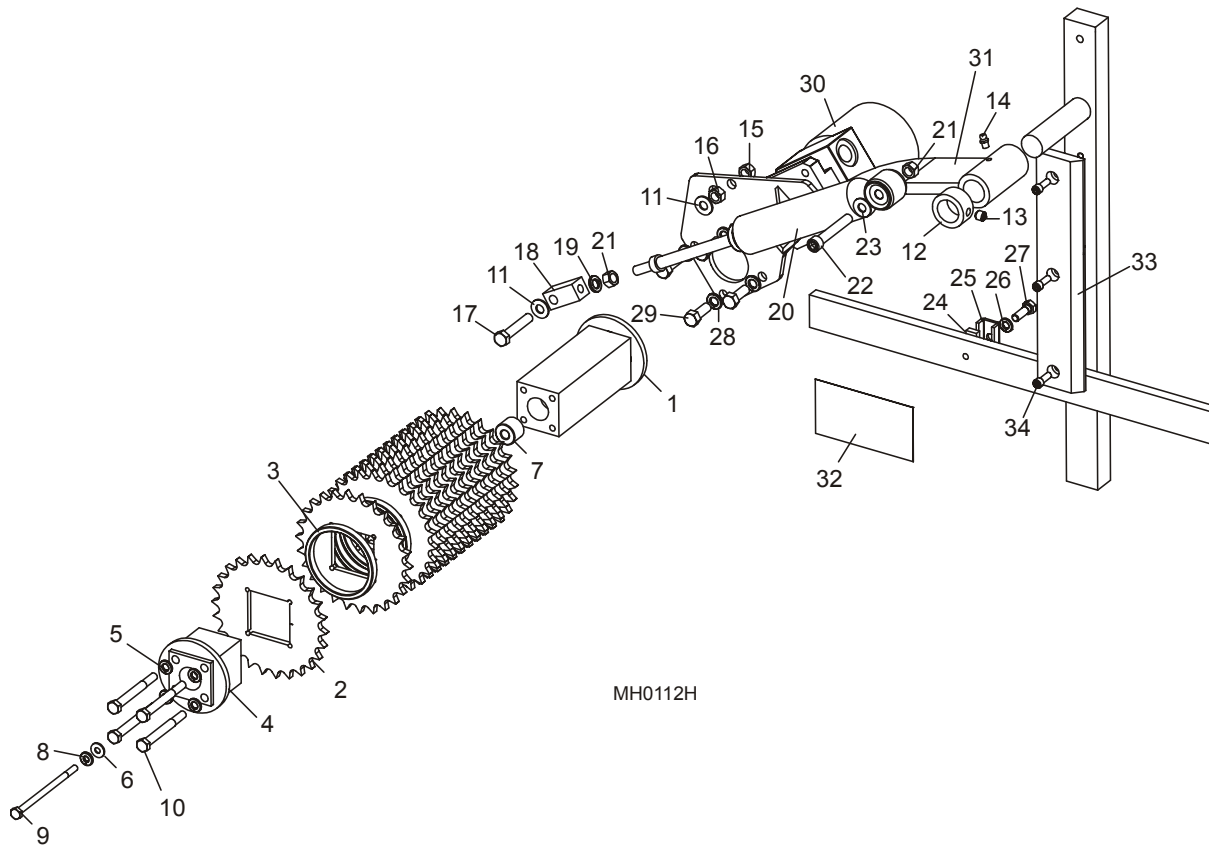

MH0112H

REF	DESCRIPTION (◆ Indicates Parts Available In Assemblies Only)	PART #	QTY (* /head)	
	FEED ROLLER ASSEMBLY, 12" MULTIHEAD	A22486-12	1	
	FEED ROLLER ASSEMBLY, 8" MULTIHEAD	A22486-8 ¹	1	
1	Shaft Weldment, Feed Roller	W22485	1	◆
2	Sprocket, Feed Roller Square Shaft	S22480	10/13 ¹	
	Sprocket, Smooth Feed Roller Square Shaft	016530	10/13 ¹	
3	Ring, Sprocket Spacer	S22481	9/12 ¹	
4	Shaft Extension Weldment, Feed Roller	W22485-12	1	◆
	Plate, Sprocket Retaining	S22483 ¹	1	
5	Washer, 5/16" Split Lock	F05011-13	4	
6	Washer, 1/4" SAE Flat	F05011-11	1	
7	Spacer, Feed Roller Shaft	S22487	1	
8	Washer, 1/4" Split Lock	F05011-14	1	
9	Bolt, 1/4-20 x 4 1/2" Hex Head Grade 5	F05005-76	1	
10	Bolt, 5/16-18 x 3" Hex Head Grade 5	F05006-62	4	
	Bolt, 5/16-18 x 1" Hex Head Grade 2	F05006-1 ¹	4	
	HANDLE, FEED ROLLER LIFT	S22488	2/machine	◆

Feed Track/Frame Parts

Feed Roller Assembly (Non-Air)

3

11	WASHER, 3/8" SAE FLAT	F05011-3	2	
12	COLLAR, FEED ROLLER LOCKING	S20159-1	1	
13	SCREW, 3/8-16 X 3/8" CUP POINT SET	F05007-68	1	
14	FITTING, 1/4-28 GREASE	P05060	1	
15	NUT, 3/8-16 HEX	F05010-1	1	
16	NUT, 3/8-16 HEX LOCK	F05010-25	1	
17	BOLT, 3/8-16 X 2" HEX HEAD FULL THREAD	F05007-16	1	
	SHOCK ASSEMBLY, FEED ROLLER	A22699	1	
18	Block, Feed Roller Piston Pivot	S20163	1	
19	Washer, 3/8" Split Lock	F05011-4	1	
20	SHOCK ASSY, FEED ROLLER	A22699	1	◆
21	Nut, 3/8-16 Hex	F05010-1	2	
22	Bolt, 3/8-16 X 2 1/2" Socket Head	F05007-24	1	
23	Washer, 3/8" SAE Flat	F05011-3	1	
24	BUMPER, FEED ROLLER	S20906	1	
25	BRACKET, FEED ROLLER BUMPER	S20310	1	
26	WASHER, 5/16" SPLIT LOCK	F05011-13	1	
27	BOLT, 5/16-24 X 1" HEX HEAD GRADE 5	F05006-77	1	
28	WASHER, 3/8" SPLIT LOCK	F05011-4	4	
29	BOLT, 3/8-16 X 1" HEX HEAD	F05007-7	4	
30	MOTOR, MG10-13-10AAAB HYDRAULIC	P20206	1	
31	ARM, FEED ROLLER MOUNT	W22113-1	1	
32	DECAL, HAND SAFETY DANGER	S20040	1	
33	PAD, POST SLIDE	033400 ²	1	
34	SCREW, 1/4-20 X 3/4" SOCKET HEAD	F05005-26	3	

¹ Alternate parts/quantities for 8" width MultiHead available before 11/99. A22486-8 replaces A22695 originally supplied before 7/94.

² Pad added Rev A1.00 (11/99).

3 Feed Track/Frame Parts

Feed Roller Assembly (Air-Lift)

3.6 Feed Roller Assembly (Air-Lift)

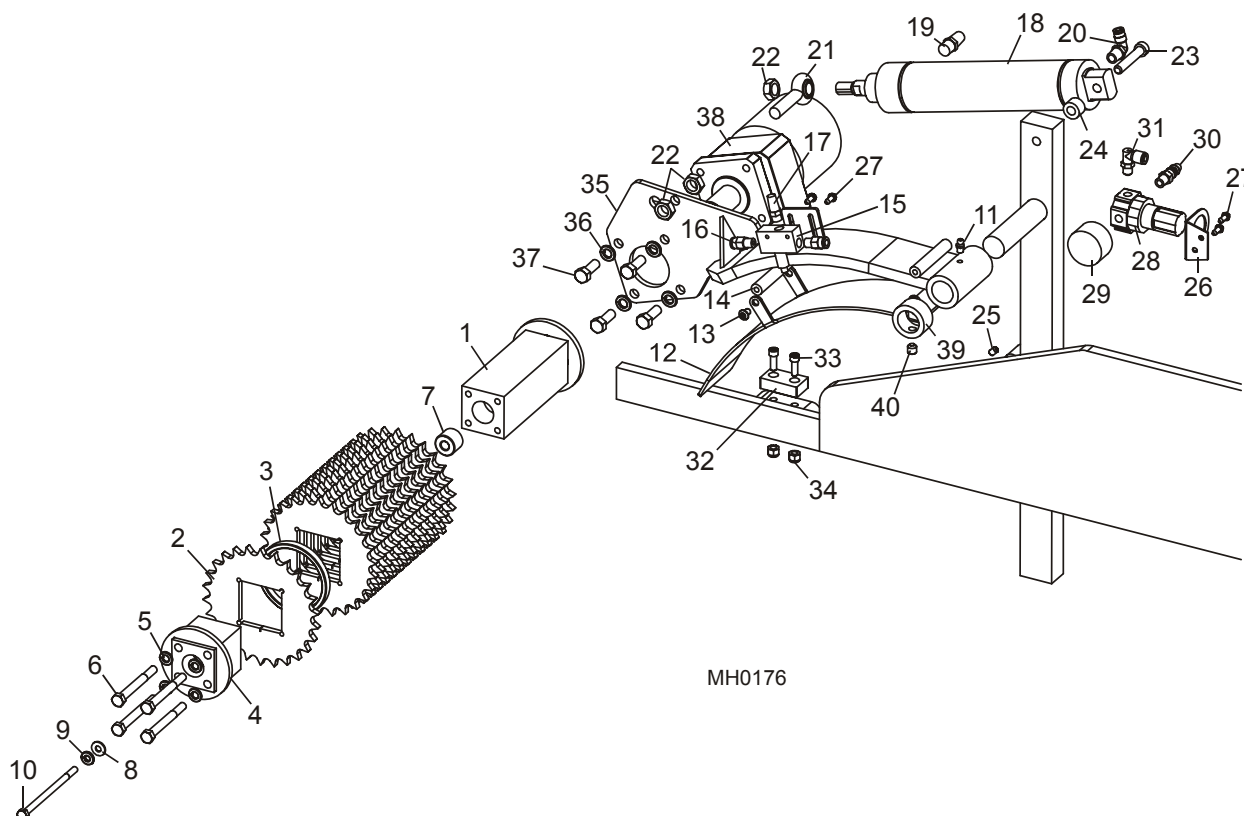

REF	DESCRIPTION (◆ Indicates Parts Available In Assemblies Only)	PART #	QTY.	
	FEED ROLLER ASSEMBLY, 12" MULTIHEAD	A22486-12	1	
1	Shaft Weldment, Feed Roller	W22485	1	◆
2	Sprocket, Feed Roller Square Shaft	S22480	13	
	Sprocket, Smooth Feed Roller Square Shaft	016530	13	
3	Ring, Sprocket Spacer	S22481	12	
4	Shaft Extension Weldment, Feed Roller	W22485-12	1	◆
5	Washer, 5/16" Split Lock	F05011-13	4	
6	Bolt, 5/16-18 x 3" Hex Head Grade 5	F05006-62	4	
7	Spacer, Feed Roller Shaft	S22487	1	
8	Washer, 1/4" SAE Flat	F05011-11	1	
9	Washer, 1/4" Split Lock	F05011-14	1	
10	Bolt, 1/4-20 x 4 1/2" Hex Head Grade 5	F05005-76	1	
	HANDLE, FEED ROLLER LIFT	S22488	2/machine	◆
11	FITTING, 1/4-28 GREASE	P05060	1	
12	BRACKET, AIR LIFT FEED ROLLER ACTUATOR	S22189	1	
13	SCREW, 1/4-20 X 3/8" BUTTON HEAD	F05005-62	4	

Feed Track/Frame Parts

Feed Roller Assembly (Air-Lift)

3

14	ROLLER, FEED ROLLER STOP	S20786	1	
15	SWITCH, FEED ROLLER AIR	P20900	1	
16	FITTING, G1/8 6MM ELBOW	502703	2	
17	MUFFLER, 1/8" NPT AIR	P20902	1	
	TUBE, 1/4" AIR	R01869	16.5 Ft.	
18	CYLINDER, 4DP6 AIR	P20901	1	
19	SILENCER, G1/8 AIR BRASS	502705	1	
20	FITTING, G1/8 6MM ELBOW	502704	1	
21	END, 1/2-20 ROD	P09137	1	
22	NUT, 1/2-20 HEX JAM	F05010-16	3	
23	PIN, FEED ROLLER AIR CYLINDER PIVOT	S20793	1	
24	SPACER, AIR CYLINDER MOUNT	S22625	1	
25	SCREW, 1/4-20 X 3/8" CUP POINT SET	F05005-47	1	
26	BRACKET, AIR REGULATOR MOUNT	P20799	1	
27	SCREW, 1/8-32 X 1/2" SLOTTED HEX	F05015-18	4	
28	REGULATOR, 300 PSI AIR FLOW	P02765	1	
29	GAUGE, 160 PSI AIR	P02766	1	
30	FITTING, 1/8" NPT MALE COUPLING	P22681	1	
31	FITTING, G1/8 6MM ELBOW	502704	1	
32	BUMPER, FEED ROLLER	038898	1	
33	BOLT, 1/4-20 X 3/4" SOCKET HEAD	F05006-26	2	
34	NUT, 1/4-20 HEX NYLON LOCK	F05010-69	2	
35	ARM, FEED ROLLER MOUNT	W22113	1	
	DECAL, HANDS CLEAR WARNING	S20040	1	
36	WASHER, 3/8" SPLIT LOCK	F05011-4	4	
37	BOLT, 3/8-16 X 1" HEX HEAD	F05007-7	4	
38	MOTOR, MG10-13-10AAAB HYDRAULIC	P20206	1	
39	COLLAR, FEED ROLLER LOCKING	S20159-1	1	
40	SCREW, 3/8-16 X 3/8" CUP POINT SET	F05007-68	1	

3

Feed Track/Frame Parts Hydraulic Tank Assembly

3.7 Hydraulic Tank Assembly

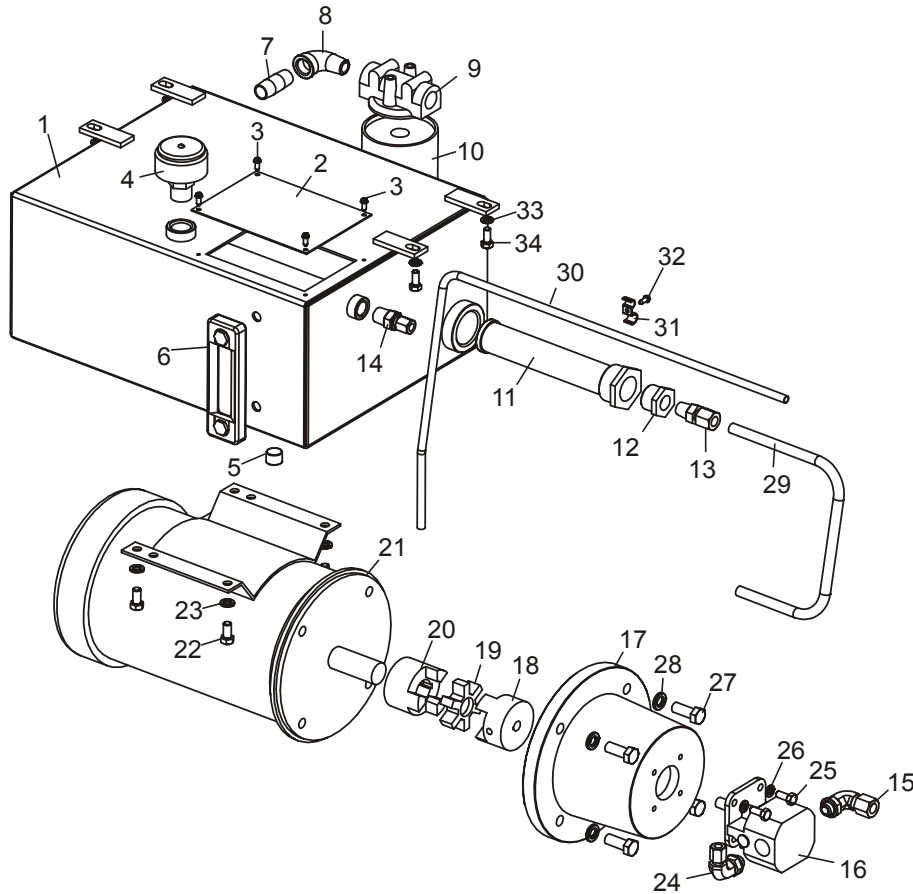

MH0248-1

REF	DESCRIPTION (◆ Indicates Parts Available In Assemblies Only)	PART #	QTY.
	TANK ASSEMBLY, HR/MGR HYDRAULIC	065489	1
	Fluid, Conoco MV32 All Weather Hydraulic (1 Gallon)	006397	8
1	Tank Weldment, Hydraulic Fluid	065490	1
2	Lid, Hydraulic Fluid Tank Access	S20331	1
3	Screw, #8-32 x 1/2" Slotted Hex Head	F05015-18	4
4	Cap, Hydraulic Tank Fill/Breather	P20212	1
5	Fitting, 1/2" NPT Male Plug	P26258	1
6	Gauge, Hydraulic Fluid Level Sight	P20211	1
7	Fitting, 1/2" NPT x 2" Long Nipple	016844	1
8	Fitting, 1/2" NPT 90° Elbow	P22684	1
9	Manifold, Hydraulic Cartridge Filter	P22683	1
10	Filter, S28 Hydraulic Cartridge	P20301	1
11	Filter, Hydraulic Tank Suction	P20210	1
12	Fitting, 1" NPT - 1/2" NPT Reducer	P20239	1
13	Fitting, 1/2" NPT - 1/2" Tube	P20243	1

Feed Track/Frame Parts
Hydraulic Tank Assembly

3

14	Fitting, 1/2" NPT - 3/8" Tube Straight	P20242	1	
15	Fitting, 1/2" Tube - 1/2" O-Ring 90° Elbow	P20245	1	
16	Pump, Hydraulic	P20213	1	
17	Adaptor, Hydraulic Pump/Motor	065484	1	
18	Coupler, L099 x 1/2" Shaft	065482	1	
19	Coupler, L100 Spider	042779	1	
20	Coupler, L100 x 1 1/8" Shaft	065483	1	
21	Motor, 5HP 3PH 3450RPM Baldor	065479 ¹	1	
22	Bolt, 3/8-16 x 3/4" Hex Head Grade 5	F05007-118	4	
23	Washer, 3/8" Split Lock	F05011-4	4	
24	Fitting, 1/2" O-Ring - 3/8" Tube 90° Elbow	P20244	1	
25	Bolt, 5/16-18 x 3/4" Hex Head Grade 5	F05006-102	4	
26	Washer, 5/16" Split Lock	F05011-13	4	
27	Bolt, 1/2-13 x 1 1/4" Hex Head Grade 5	F05008-37	4	
28	Washer, 1/2" Split Lock	F05011-9	4	
29	TUBE, 1/2" HYDRAULIC	R01629	As Req'd	
30	TUBE, 3/8" HYDRAULIC	R01628	As Req'd	
31	CLAMP, 1/2" X 3/8" HOSE	S02845	As Req'd	
32	BOLT, #8-32 X 1/2 SLOTTED HEX HEAD	F05015-18	As Req'd	

¹ Use Kit 065492 to retrofit 4HP motors on earlier revisions (Kit includes Motor, Couplings, Pump Adaptor & Hardware)

3

Feed Track/Frame Parts

Hydraulic Valve Assembly (2 and 4-Head)

3.8 Hydraulic Valve Assembly (2 and 4-Head)

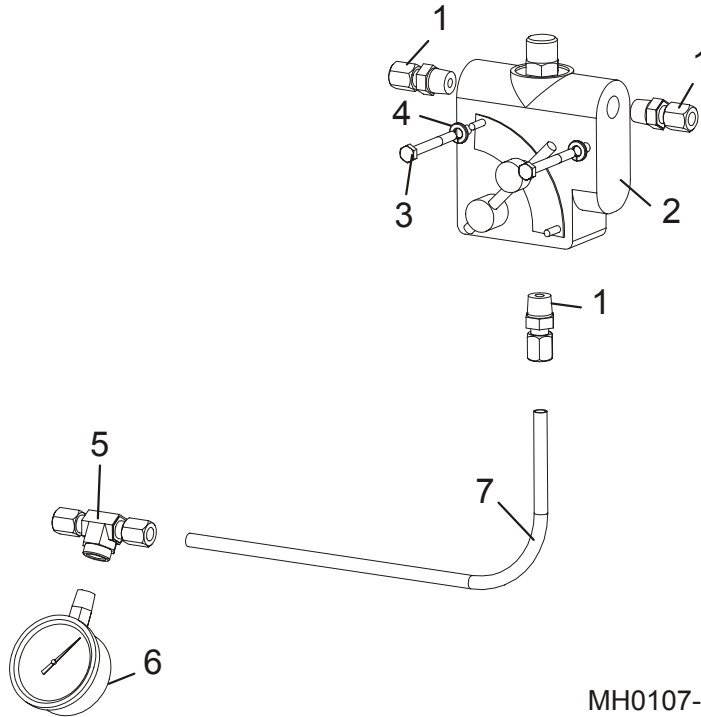

MH0107-1

REF	DESCRIPTION (◆ Indicates Parts Available In Assemblies Only)	PART #	QTY.	
1	FITTING, 3/8" TUBE - 3/8" NPT STRAIGHT	P20744	3	
2	VALVE, HYDRAULIC FLOW CONTROL	P20743	1	
3	BOLT, 1/4-20 X 2 1/2" HEX HEAD	F05005-72	2	
4	WASHER, 1/4" SPLIT LOCK	F05011-14	2	
5	FITTING, 3/8" TUBE - 1/4" NPT - 3/8" TUBE 'T'	P20345	1	
6	GAUGE, 3000 PSI COLOR-CODED FACE	P10052	1	
7	TUBE, 3/8" HYDRAULIC	R01628	As Req'd	

3.9 Hydraulic Valve Assembly (6-Head)

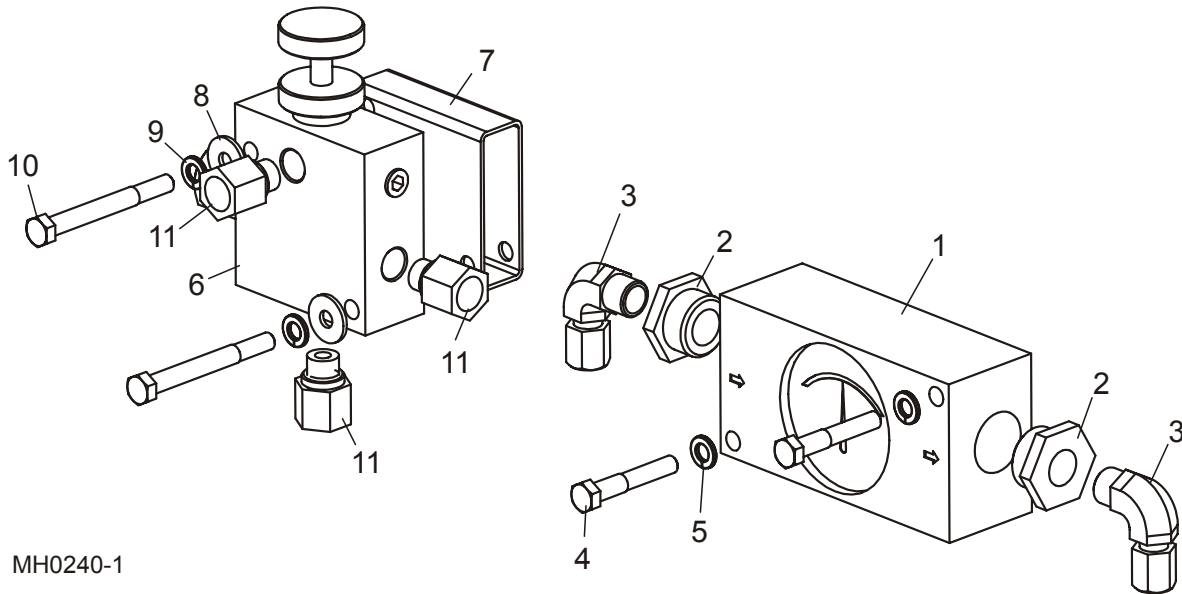

MH0240-1

REF	DESCRIPTION (◆ Indicates Parts Available In Assemblies Only)	PART #	QTY.
1	METER, FLOW	033414	1
2	BUSHING, 3/4" MPT X 3/8" FPT	033415	2
3	FITTING, 3/8" MPT X 3/8" TUBE 90°	033416	2
4	BOLT, 5/16-18 X 2" HEX HEAD GRADE 5	F05006-79	2
5	WASHER, 5/16" SPLIT LOCK	F05011-13	2
	VALVE ASSEMBLY, 6-HEAD/MGR FLOW CONTROL	006486	1
6	Valve, 6-head Merry-Go-Round Flow Control	033413	1 ◆
7	Spacer, MultiHead Flow Control Valve	006064	1
8	Washer, 5/16" Standard Flat	F05011-16	2
9	Washer, 5/16" Split Lock	F05011-13	2
10	Bolt, 5/16-18 x 3" Hex Head Grade 5	F05006-62	2
11	Fitting, 3/8" SAE x 3/8" NPT Adaptor	006487	3

3 Feed Track/Frame Parts

Crowder Fence Assembly

3.10 Crowder Fence Assembly

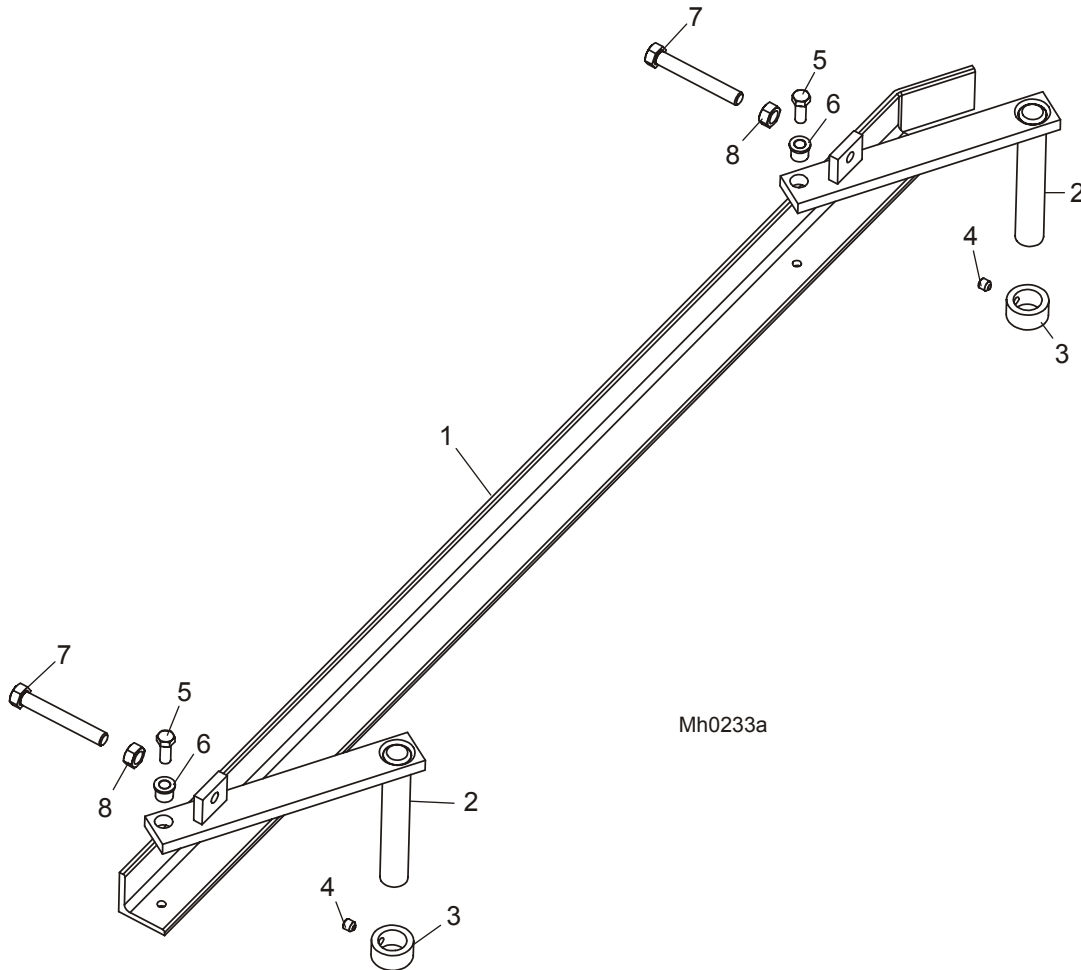

REF	DESCRIPTION (◆ Indicates Parts Available In Assemblies Only)	PART #	QTY.
1	FENCE, FEED CROWDER	S22260	1
2	BRACKET, CROWDER FENCE PIVOT END	036338	2
3	COLLAR, LOCKING	S20159	2
4	SCREW, 3/8-16 X 3/8" CUP POINT SET	F05007-68	2
5	BOLT, 3/8-16 X 7/8" HEX HEAD GRADE 5	F05007-185	2
6	BUSHING, 3/4" X .505" FLANGED	036336	2
7	BOLT, 1/2-13 X 3 1/2" HEX HEAD FULL THREAD	F05008-11	2
8	NUT, 1/2-13 HEX	F05010-35	2

INDEX

B

- blade guide
 - inner 2-12
 - outer 2-13
- blade housing cover 2-21
- blade tensioner
 - block assembly 2-1
 - hand pump 3-1
 - release handle 2-3
- blade wheel
 - drive side 2-17
 - idle side 2-19

F

- feed roller
 - air-lift 3-11
 - standard 3-7
- feed track 3-4
- feed track spacers 3-6
- fence 3-17

H

- hydraulic tank 3-15, 3-16

P

- parts list
 - how to use 1-1
- perimeter fence 3-2

S

- saw head mount 2-5
- sawdust chute 2-22

U

- up/down 2-15