

## user manual

Instrukcja obsługi | Руководство пользователя  
Manuel de l'Utilisateur | Betriebsanweisung  
Bruksanvisning | Manual del Usuario  
Betjeningsvejledning | Gebruikershandleiding  
Käyttöohjeet | Manual de utilizare | Bruksanvisning  
Manuale d'uso | Příručka uživatele

Zachować do przyszłego użytku  
Сохраните для последующего использования  
A conserver pour une utilisation future  
Für zukünftige Benutzung aufbewahren  
Behold for senere bruk  
Säilytä nämä käyttöohjeet tulevaa tarvetta marten  
Opbevar manualen til fremtidig brug  
Bewaren voor gebruik in de toekomst  
Conservare il presente manuale a l'uso futuro  
Păstrați acest manual pentru utilizare viitoare  
Conservar para futuras consultas  
Uchovajte pro další použití



## INDUSTRIAL PRODUCTS

### Safety, Setup, Operation & Maintenance Manual

---

MultiHead Resaw

Rev. A2.00

---



**Safety is our #1 concern!** Read and understand all safety information and instructions before operating, setting up or maintaining this machine.

*Form #738*

# Table of Contents

# Section-Page

## ABOUT THIS MANUAL

1-V

### SECTION 1 SAFETY

1-1

1.1	Safety Symbols.....	1-1
1.2	Safety Instructions.....	1-2
	<i>Observe Safety Instructions .....</i>	<i>1-2</i>
	<i>Wear Safety Clothing .....</i>	<i>1-3</i>
	<i>Keep MultiHead And Area Around MultiHead Clean .....</i>	<i>1-3</i>
	<i>Dispose Of Sawing By-Products Properly.....</i>	<i>1-3</i>
	<i>Check MultiHead Before Operation .....</i>	<i>1-4</i>
	<i>Keep Persons Away.....</i>	<i>1-4</i>
	<i>Keep Hands Away.....</i>	<i>1-5</i>
	<i>Use Proper Maintenance Procedures.....</i>	<i>1-6</i>
	<i>Keep Safety Labels In Good Condition.....</i>	<i>1-7</i>

### SECTION 2 OPERATION

2-1

2.1	Control Overview .....	2-1
2.2	Multihead Setup.....	2-3
2.3	Hydraulic Overview .....	2-6
2.4	Perimeter Fence Operation .....	2-8
2.5	Saw Blade Removal .....	2-9
2.6	Saw Blade Installation.....	2-11
	<i>To Tension All Blades .....</i>	<i>2-13</i>
	<i>To Tension Selected Blades.....</i>	<i>2-14</i>
	<i>Saw Blade Tracking .....</i>	<i>2-14</i>
2.7	Saw Height Adjustment.....	2-17
2.8	Fence Adjustment.....	2-20
2.9	Blade Guide Arm Adjustment .....	2-21
2.10	Machine Start.....	2-22
2.11	Machine Shutdown.....	2-26
2.12	Operation Procedure.....	2-28

### SECTION 3 MAINTENANCE

3-1

3.1	Blade Guides (Ceramic Disk/Roller).....	3-1
	<i>Blade Guide Inspection .....</i>	<i>3-3</i>
	<i>Blade Guide Roller Rebuild .....</i>	<i>3-6</i>
	<i>Blade Guide Roller Replacement.....</i>	<i>3-6</i>
	<i>Blade Guide Housing .....</i>	<i>3-7</i>
3.2	Blade Guides (Block/Roller Guides).....	3-1
	<i>Blade Guide Inspection .....</i>	<i>3-2</i>
	<i>Blade Guide Rebuild .....</i>	<i>3-5</i>
	<i>Blade Guide Replacement.....</i>	<i>3-5</i>
	<i>Blade Guide Housing .....</i>	<i>3-6</i>
3.3	Saw Head Up/Down Pad Adjustment .....	3-7
3.4	Blade Height Indicator Adjustment.....	3-8
3.5	Blade Tension Shutoff Switch Adjustment .....	3-9
3.6	Blade Wheel Bearing Lubrication .....	3-10
3.7	Blade Wheel Belt Replacement.....	3-11

## Table of Contents

## Section-Page

3.8	Drive Belt Tension .....	3-12
3.9	Electric Motor Lubrication .....	3-13
3.10	Feed Roller Pivot Lubrication .....	3-14
3.11	Feed Roller Assembly Rebuild.....	3-15
3.12	Feed Track Bearing Lubrication.....	3-16
3.13	Feed Tube Sawdust Removal .....	3-17
3.14	Hydraulic System Maintenance.....	3-18
3.15	Perimeter Fence Pivot Lubrication .....	3-19
3.16	Saw Head Mounting Tube Lubrication .....	3-20
3.17	Tension Assembly Lubrication.....	3-21
3.18	Tensioner Screw Adjustment .....	3-22
3.19	Up/Down Drive Lubrication.....	3-24
3.20	Routine Maintenance Schedule .....	3-25
3.21	Periodic Maintenance .....	3-26
3.22	Electrical Problems.....	3-27
	<i>Head Will Not Start.....</i>	<i>3-27</i>
	<i>Cannot Start Track.....</i>	<i>3-27</i>
	<i>Saw Starts Then Shuts Off.....</i>	<i>3-27</i>
	<i>Saw Runs Then Shuts Off.....</i>	<i>3-27</i>
	<i>No Braking (Global models only).....</i>	<i>3-27</i>
	<i>Troubleshooting Hints: .....</i>	<i>3-28</i>

### SECTION 4 ALIGNMENT

4-1

4.1	Preliminary Alignment .....	4-1
4.2	Blade Guide Alignment (Block/Roller).....	4-4
	<i>Saw Head Tilt Adjustment.....</i>	<i>4-4</i>
	<i>Prepare Blade Guides For Alignment .....</i>	<i>4-8</i>
	<i>Blade Guide Side-To-Side Tilt Alignment.....</i>	<i>4-8</i>
	<i>Blade Guide Vertical Tilt Alignment.....</i>	<i>4-10</i>
	<i>Final Blade Guide Alignment Procedures .....</i>	<i>4-12</i>
4.3	Blade Guide Alignment (Ceramic Disk/Roller).....	4-13
	<i>Prepare Blade Guides For Alignment .....</i>	<i>4-13</i>
	<i>Blade Guide Vertical Tilt Alignment.....</i>	<i>4-15</i>
	<i>Blade Deflection.....</i>	<i>4-17</i>
	<i>Blade Guide Side-To-Side Tilt Alignment.....</i>	<i>4-18</i>
	<i>Saw Head Tilt.....</i>	<i>4-19</i>

### SECTION 5 SPECIFICATIONS

5-1

5.1	Dimensions .....	5-1
5.2	Cutting Capacity .....	5-2
5.3	Motor Specifications .....	5-3
5.4	Electrical diagrams .....	5-4
5.5	Belt Sizes .....	5-9
5.6	Fluid Requirements .....	5-10
5.7	Air Service Requirements.....	5-11
5.8	Dust Extractor Specifications .....	5-11
5.9	Hydraulic System .....	5-12
5.10	Connection Specifications .....	5-14

**Table of Contents**

**Section-Page**

**INDEX**

**1-I**

## ABOUT THIS MANUAL

This manual is to replace or to be used with all previous information received on the Wood-Mizer® \* MultiHead. All future mailings will be an addition to or a revision of individual sections of this manual as we obtain new information.

The information and instructions given in this manual do not amend or extend the limited warranties for the equipment given at the time of purchase.

For general information regarding Wood-Mizer and our “Forest to Final Form” products, please refer to the All Products Catalog in your support package.

---

\*Wood-Mizer® is a registered trademark of Wood-Mizer Products, Inc.

## SECTION 1 SAFETY

### 1.1 Safety Symbols

The following symbols and signal words call your attention to instructions concerning your personal safety. Be sure to observe and follow these instructions.



**DANGER!** indicates an imminently hazardous situation which, if not avoided, will result in death or serious injury.



**WARNING!** suggests a potentially hazardous situation which, if not avoided, could result in death or serious injury.



**CAUTION!** refers to potentially hazardous situations which, if not avoided, may result in minor or moderate injury or damage to equipment.



**IMPORTANT!** indicates vital information.

**NOTE:** gives helpful information.



Warning stripes are placed on areas where a single decal would be insufficient. To avoid serious injury, keep out of the path of any equipment marked with warning stripes.



## 1.2 Safety Instructions

**NOTE:** ONLY safety instructions regarding personal injury are listed in this section. Caution statements regarding only equipment damage appear where applicable throughout the manual.

### *Observe Safety Instructions*



**IMPORTANT!** Read the entire Operator's Manual before operating the MultiHead. Take notice of all safety warnings throughout this manual and those posted on the machine. Keep this manual with this machine at all times, regardless of ownership.

Also read any additional manufacturer's manuals and observe any applicable safety instructions including dangers, warnings, and cautions.

Only persons who have read and understood the entire operator's manual should operate the MultiHead. The MultiHead is not intended for use by or around children.

**IMPORTANT!** It is always the owner's responsibility to comply with all applicable federal, state and local laws, rules and regulations regarding the ownership, and operation of your Wood-Mizer MultiHead. All Wood-Mizer MultiHead owners are encouraged to become thoroughly familiar with these applicable laws and comply with them fully while using the machine.



## Wear Safety Clothing



**WARNING!** Secure all loose clothing and jewelry before operating the MultiHead. Failure to do so may result in serious injury or death.

**WARNING!** Always wear gloves and eye protection when handling bandsaw blades. Changing blades is safest when done by one person! Keep all other persons away from area when coiling, carrying or changing a blade. Failure to do so may result in serious injury.

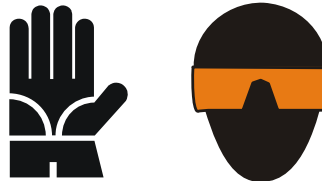

**WARNING!** Always wear eye, ear, respiration, and foot protection when operating or servicing the MultiHead.



## Keep MultiHead And Area Around MultiHead Clean



**DANGER!** Maintain a clean and clear path for all necessary movement around the MultiHead and lumber stacking areas. Failure to do so will result in serious injury.

## Dispose Of Sawing By-Products Properly



**IMPORTANT!** Always properly dispose of all sawing by-products, including sawdust and other debris.

### **Check MultiHead Before Operation**

 **DANGER!** Make sure all guards and covers are in place and secured before operating MultiHead. Failure to do so may result in serious injury.



### **Keep Persons Away**

 **DANGER!** Keep all persons out of the path of moving equipment and lumber when operating the MultiHead. Failure to do so will result in serious injury.

**DANGER!** Always be sure all persons are out of the path of the blade before starting the motor. Failure to do so will result in serious injury.

 **WARNING!** Allow blades to come to a complete stop before entering area protected by perimeter fence. Failure to do so will result in serious injury.

**WARNING!** Use the tension release handle to push the blade wheel against the brake before opening the blade housing cover. Failure to do so will result in serious injury.

### **Keep Hands Away**



**DANGER!** Always shut off the MultiHead before changing the blade. Failure to do so will result in serious injury.

**DANGER!** Motor components can become very hot during operation. Avoid contact with any part of a hot motor. Contact with hot motor components can cause serious burns. Therefore, never touch or perform service functions on a hot motor. Allow the motor to cool sufficiently before beginning any service function.

**DANGER!** Always keep hands away from moving bandsaw blade. Failure to do so will result in serious injury.

**DANGER!** Always be aware of and take proper protective measures against rotating shafts, pulleys, fans, etc. Always stay a safe distance from rotating members and make sure that loose clothing or long hair does not engage rotating members resulting in possible injury.



**WARNING!** Always stop the saw heads whenever the MultiHead is not cutting. Failure to do so may result in serious injury.

**WARNING!** Use extreme caution when spinning the blade wheels by hand. Make sure hands are clear of blade and wheel spokes before spinning. Failure to do so may result in serious injury.

## Use Proper Maintenance Procedures

 **DANGER!** Make sure all electrical installation, service and/or maintenance work is performed by a qualified electrician and is in accordance with applicable electrical codes.

**DANGER!** Hazardous voltage inside the electric MultiHead disconnect box, control boxes, and at the motors can cause shock, burns, or death. Disconnect and lock out power supply before servicing! Keep all electrical component covers closed and securely fastened during MultiHead operation.



 **WARNING!** Consider all electrical circuits energized and dangerous.

**WARNING!** Disconnect and lock out power supply before servicing the MultiHead! Failure to do so may result in serious injury.

**WARNING!** Never assume or take the word of another person that the power is off; check it out and lock it out.

**WARNING!** Do not wear rings, watches, or other jewelry while working around an open electrical circuit.

**WARNING!** Remove the blade before performing any service to the motors or MultiHead. Failure to do so may result in serious injury.

 **DANGER!** Never clean the blade or blade wheels using the hand-held brush or scraper whilst the saw blade is in motion.

***Keep Safety Labels In Good Condition***



**IMPORTANT!** Always be sure that all safety decals are clean and readable. Replace all damaged safety decals to prevent personal injury or damage to the equipment. Contact your local distributor, or call your Customer Service Representative to order more decals.

**IMPORTANT!** If replacing a component which has a safety decal affixed to it, make sure the new component also has the safety decal affixed.

## SECTION 2 OPERATION

### 2.1 Control Overview

#### 1. Control Panel

See **Figure 2-1**. The control panel includes switches to start and stop the feed track and each saw head.

**NOTE:** None of the controls will function if the perimeter fence is not in the raised position. The saw blades also must be tensioned with 50 psi (345kPa) of recommended settings to operate the control panel.

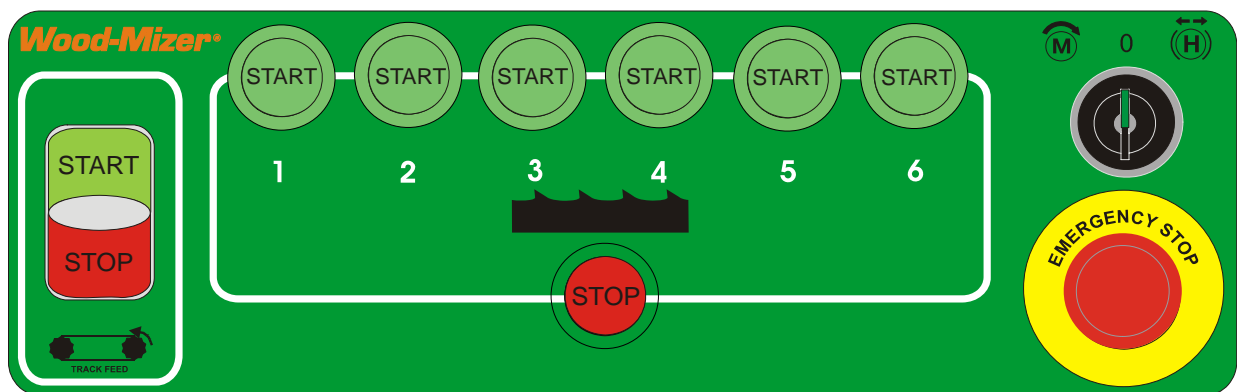



**FIG. 2-1 CONTROL PANEL COMPONENTS.**

#### 2. Track Feed

To start the feed track, press the START button. To stop the track, press the STOP button.

#### 3. Key Switch

The key switch has three positions:

- “0” position - all electrical circuits are off,
-  position - all electrical circuits are on,
-  position - releases the motor disk brake, the blade and the track feed motors are off.

#### 4. Blade/Track Stop

Push the blade/track stop button to stop all saw and track feed motors. Use the track feed and saw start buttons to restart the resaw.

#### 5. Emergency Stop

Push the emergency stop button to stop all saw and track feed motors. Turn the emergency stop clockwise to release the stop. The resaw will not restart until the emergency stop is released.

#### 6. Remote Control Box

**See Figure 2-2.** There are two controls at the outfeed end of the resaw. These controls allow the track to be started and stopped and saw motors to be shut down by an operator located at the end of the resaw.

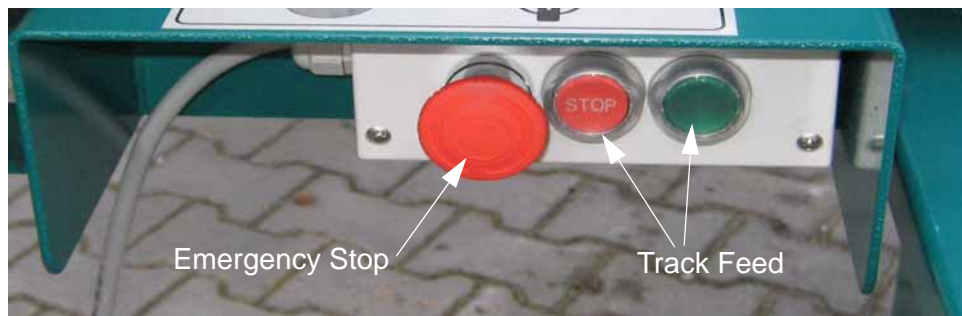

**FIG. 2-2**

- Push the emergency stop button to shut off all saw and track motors. The resaw must be restarted at the control panel. Twist the emergency stop clockwise to release the stop.
- The track feed switch can be used by the off-bearer to stop the feed track. Turn the lever to OFF to stop the track. Restart the track by turning the lever to START. When you release the switch, it will return to ON and the track will restart.



## 2.2 Multihead Setup



**IMPORTANT!** Before starting to use the Multihead you have to meet the following conditions:

- Set up the Multihead on firm and level ground.
- The Multihead can be operated with the sawdust collection system only.
- The Multihead can be operated under roof only.
- The Multihead can be operated in temperature range from  $-15^{\circ}\text{C}$  to  $40^{\circ}\text{C}$  only.
- The Multihead operator's position is shown below.

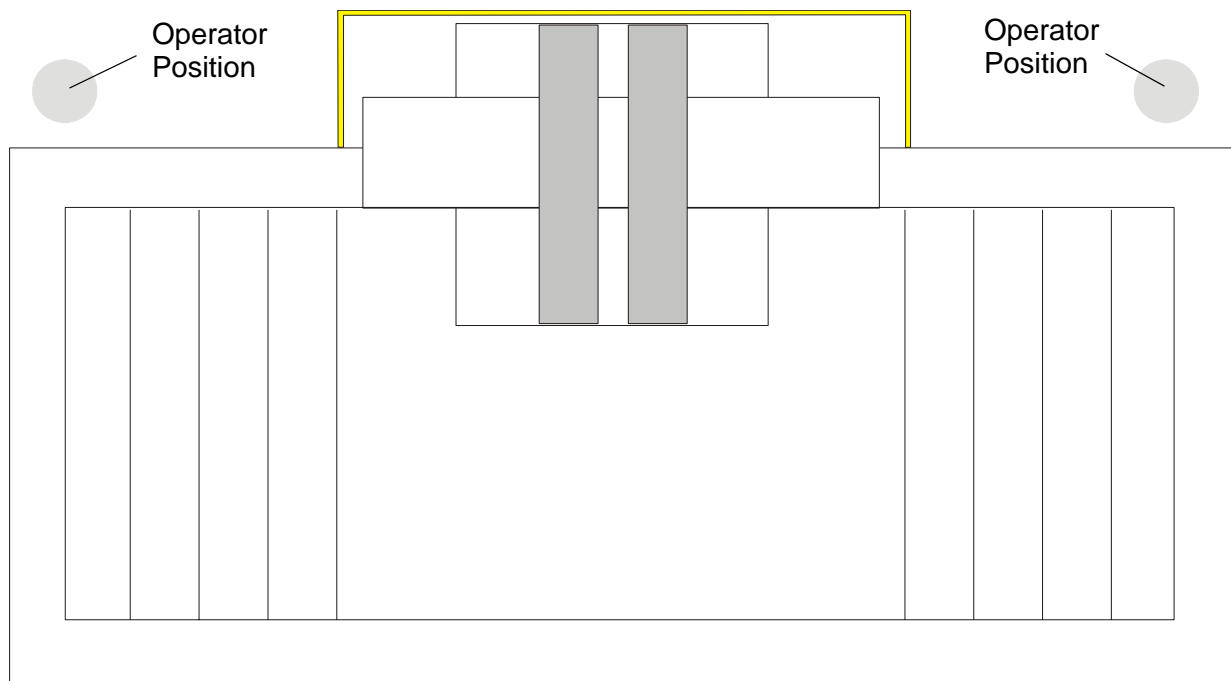

mh0232

- Have a qualified electrician install the power supply (according to EN 60204 Standard). The power supply must meet the specifications given in the table below.

**See Table 2-1.** Depending on the number of saw heads, you should use different circuit breakers and power cord cross sections. See the table below for the required connection

## 2 Operation

### Multihead Setup

---

specifications.

Number of saw heads	Circuit Breaker [A]	Power Cord Cross Section [mm <sup>2</sup> ]
2	50	10
2	45	6
4	86	16
6	128	25
6	160	50

**TABLE 2-1**



**IMPORTANT!** When starting the machine for the first time, check that blade rotation direction is as indicated by the arrow located on the blades covers. If the rotation direction is incorrect, invert the phases in the phase inverter located in the power socket (electric box). Setting the phases in the phase inverter correctly will ensure correct rotation directions of all machine motors.



**IMPORTANT!** When starting the machine for the first time, let it run without any load for 1-2 hours. It will let the infeed and outfeed tables drive components to grind in.

- The resaw can be lifted using the forklift only. Forklift must be rated for at least 4000kg. Resaw is equipped with forklift pockets. Insert the forks into the pockets

shown on the picture below. Secure the forks using the clamp bolts.

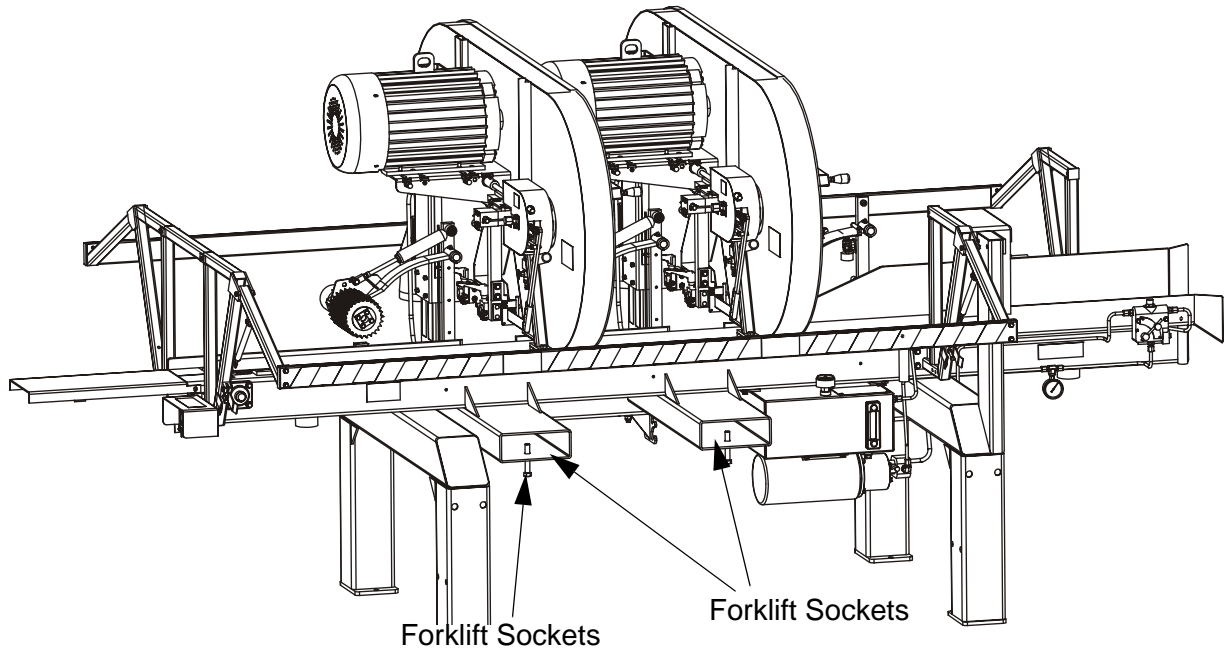

**FIG. 2-3**

## 2.3 Hydraulic Overview

The hydraulic system has a cartridge filter, flow control valve, reservoir with in-line suction filter, pump motor, and hydraulic lines and fittings.

### 1. Hydraulic Fluid

Use a good grade of automatic transmission fluid (ATF) such as DEXRON II for most installations and climate conditions.

### 2. Filter (Cartridge)

See **Figure 2-4**. The cartridge filter is a replaceable type S28 hydraulic filter.

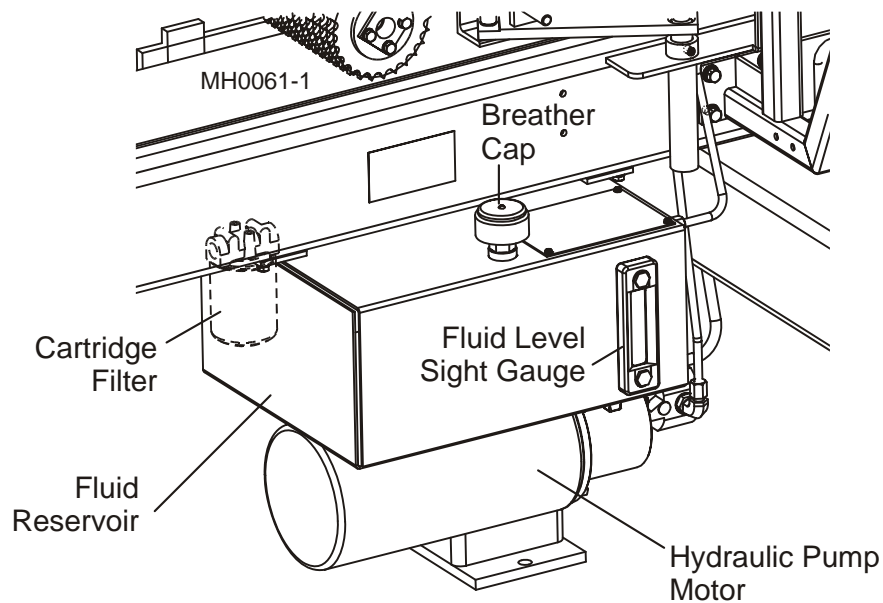

**FIG. 2-4**

### 3. Hydraulic Pump/Motor

The hydraulic pump is powered by a 4 horsepower electric motor. All adjustments are factory set.

#### 4. Flow Control Valve

The flow control valve lever controls the Feed Rate (conveyor track speed). The valve provides feed rates from 0 to 100+ feet (30 m) per minute.

**See Figure 2-5.** Adjust the Track Feed Rate by unscrewing the valve handle, pivoting the indicator to the desired speed, and retightening the handle.

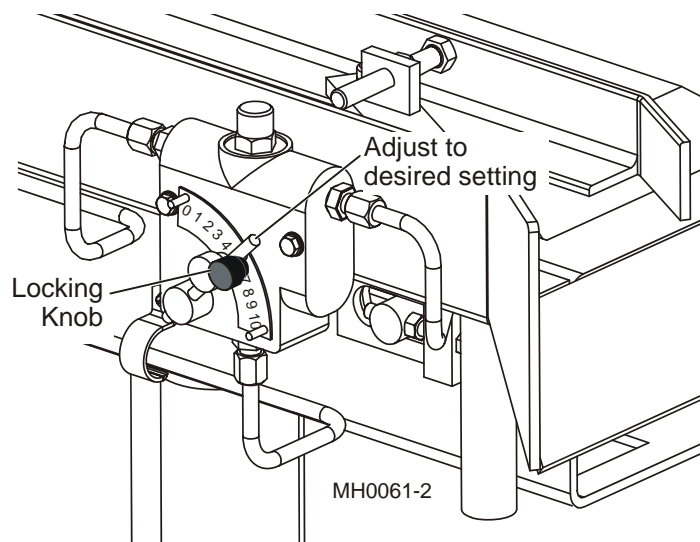

**FIG. 2-5**

## 2.4 Perimeter Fence Operation

To remove and install blades or perform any service that requires access to the moving parts of the MultiHead, lower the perimeter fence.

**See Figure 2-6.** Lowering the perimeter fence disables all electric functions of the resaw. This safety feature protects persons from accidental injury caused by moving parts or blades. When service is complete, return the perimeter fence to its raised position. This will enable the resaw to be started at the control panel.

 **WARNING!** Allow blades to come to a complete stop before entering area protected by perimeter fence. Failure to do so will result in serious injury.

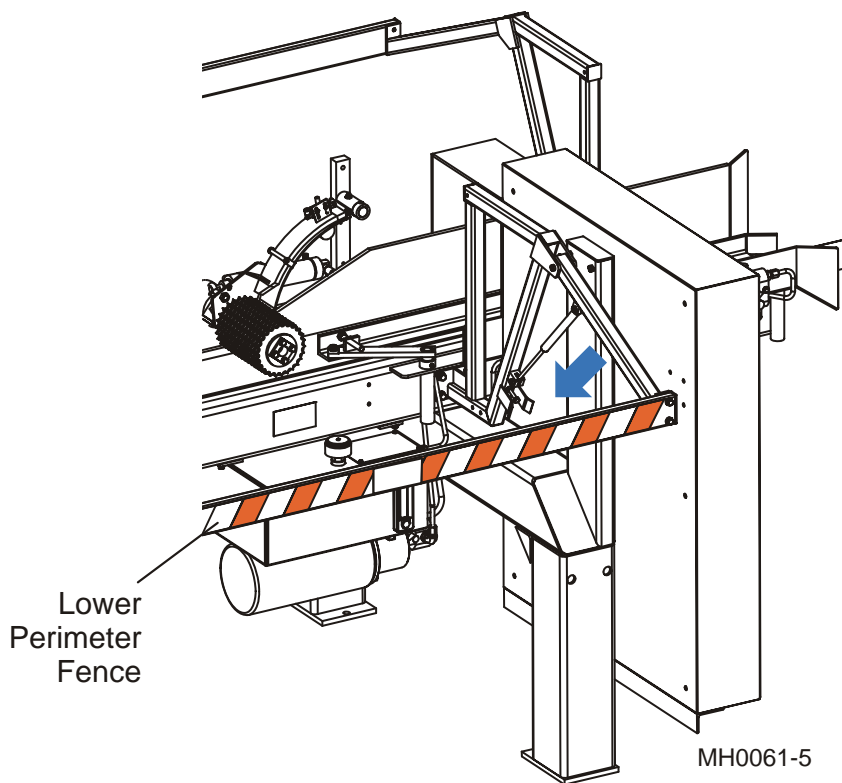

**FIG. 2-6**

## 2.5 Saw Blade Removal



**WARNING!** Allow blades to come to a complete stop before entering area protected by perimeter fence. Failure to do so will result in serious injury.

**WARNING!** Always wear gloves and eye protection when handling bandsaw blades. Changing blades is safest when done by one person! Keep all other persons away from area when coiling, carrying or changing a blade. Failure to do so may result in serious injury.

1. Open the blade covers by pulling on the knob until the covers rest in the open position. The blade covers are counterbalanced for ease of operation.

See Figure 2-7.

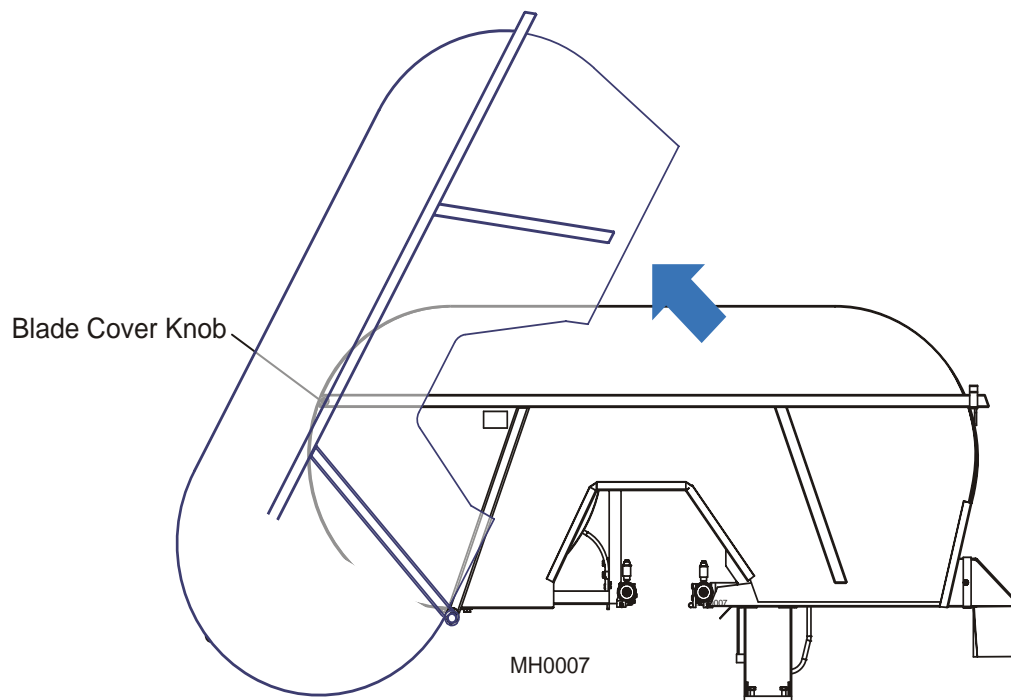

FIG. 2-7

## 2 Operation

### Saw Blade Removal

2. Release the blade tension on all saw heads by turning the tensioner relief valve counterclockwise.

See Figure 2-8.

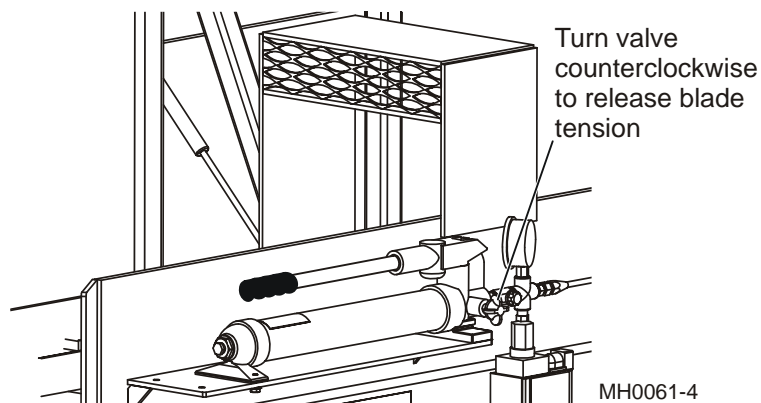

FIG. 2-8

3. Release the remainder of the tension from the blade to be removed by turning the check valve on the saw head clockwise. As you turn the check valve, pull up on the tension release lever. This will push the idle blade wheel against the wheel brake and create enough slack in the blade for removal.

See Figure 2-9.

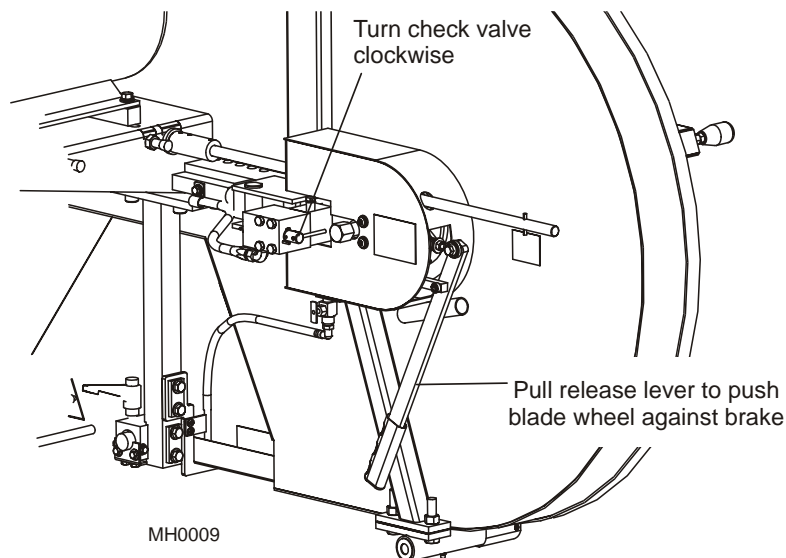

FIG. 2-9

4. Remove the blade, wipe it dry, and set aside.



## 2.6 Saw Blade Installation



**WARNING!** Always wear gloves and eye protection when handling bandsaw blades. Changing blades is safest when done by one person! Keep all other persons away from area when coiling, carrying or changing a blade. Failure to do so may result in serious injury.

See **Figure 2-10**. Uncoil a blade and install it around the two blade wheels. Make sure the teeth located between the blade guide assemblies point to the drive side of the machine. Insert the blade between the guide rollers and guide blocks.

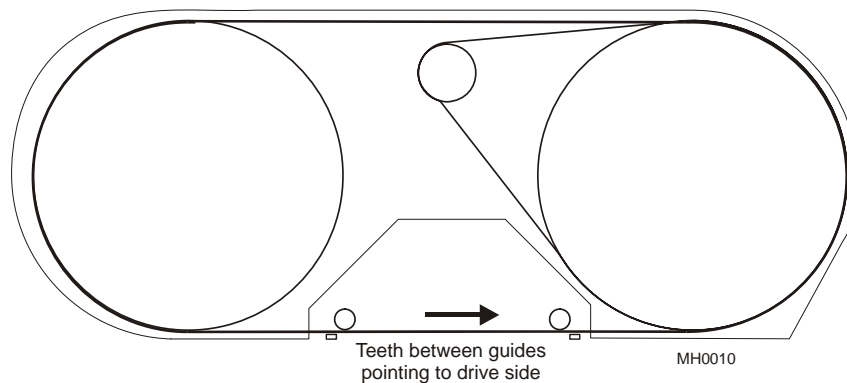

**FIG. 2-10 REV. A1.00 - A1.03**

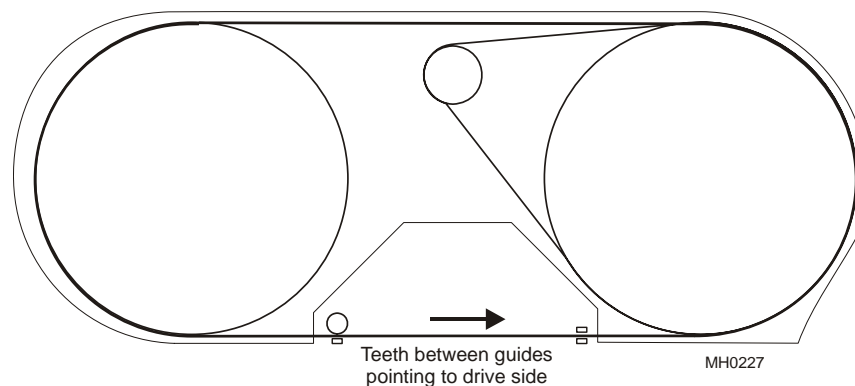

**FIG. 2-10 REV. A2.00+**

See **Figure 2-11**. Push the blade onto the wheels. 1" blades should be placed so the gullet is even with the front edge of the blade wheels (+0, -1/16"). 1 1/4" blades should be placed so the gullet is out from the front edge of the wheels 1/8" (+0, -1/16"). Make sure

## 2 Operation

### Saw Blade Installation

---

the back edge of the blade does not touch the back of the blade housing.

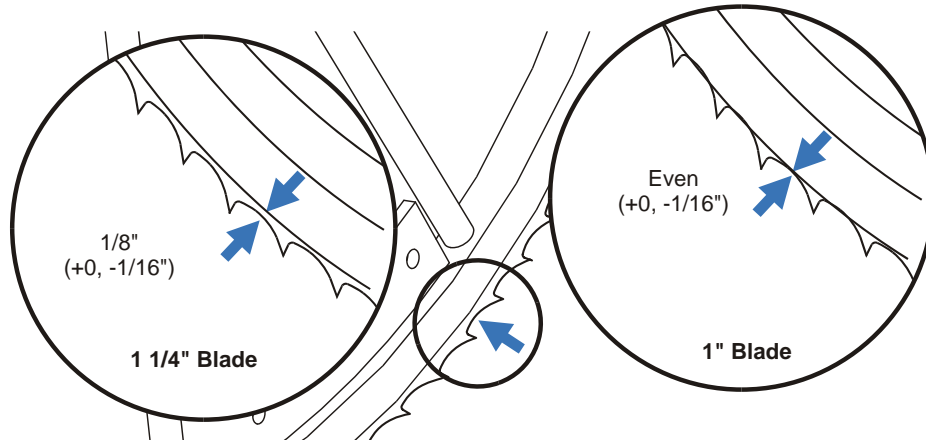
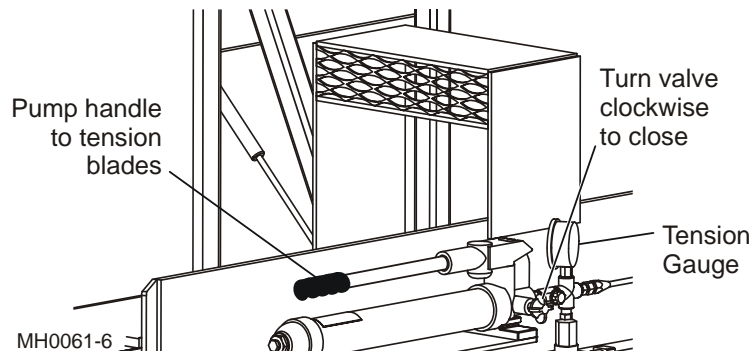

**FIG. 2-11**

**To Tension All Blades**

1. Check blades for proper installation.
2. Turn the tensioner relief valve clockwise to close. Pump the tensioner handle until the tension gauge indicates the desired setting.

See Figure 2-12.



**FIG. 2-12**

See Table 2-2. Recommended tension setting for the blades you are using are listed below.

Blade Size	Acceptable Range*	Best
.035" x 1"	1500-1800 psi (10340kPa-12410kPa)	1700 psi (11721kPa)
.042" x 1"	1800-2100 psi (12410kPa-14479kPa)	2000 psi (13790kPa)
.035" x 1 1/4"	1800-2100 psi (12410kPa-14479kPa)	2000 psi (13790kPa)
.042" x 1 1/4"	2100-2400 psi (14479kPa-16547kPa)	2300 psi (15858kPa)

**TABLE 2-2**

**\*NOTE:** You should tension the blades 200-300 pounds (91-136kg) more than shown in the above table when first setting up the MultiHead. After you start the machine and the wheel tires and blades heat up, the blade tension will drop. Monitor the tension gauge as you operate the resaw. Apply tension as necessary to maintain the recommended setting for the blades you are using.



**CAUTION!** Remove tension from the blades when the MultiHead is not in use.

Using these guidelines for blade tension allows room for variances while maintaining good cutting performance.

### ***To Tension Selected Blades***

During some operations you may not want to run all the saw blades. If you intend to operate the resaw with one or more heads not cutting, remove the blade from the saw heads that will not be used.

Follow Steps 1-2 as before to tension remaining blades. The tension assemblies of heads without blades will contact a stop bracket and allow the tensioning system to operate as if all the heads had blades installed.

### ***Saw Blade Tracking***

Once you have installed and tensioned the blades, you will need to make sure that they travel on the blade wheels properly.

1. Spin the blade wheels by hand several times to allow the blade to locate itself on the wheels.



**WARNING!** Use extreme caution when spinning the blade wheels by hand. Make sure hands are clear of blade and wheel spokes before spinning. Failure to do so may result in serious injury.

2. After the blades have come to a complete stop, check that each blade is positioned properly on the blade wheels.

**See Figure 2-13.** 1" blades should be placed so the gullet is even with the front edge of the blade wheels (+0, -1/16" [1,6mm]). 1 1/4" blades should be placed so the gullet is out from the front edge of the wheels 1/8"(3mm) (+0, -1/16"[1,6mm]). Make sure the back

edge of the blade does not touch the back of the blade housing.

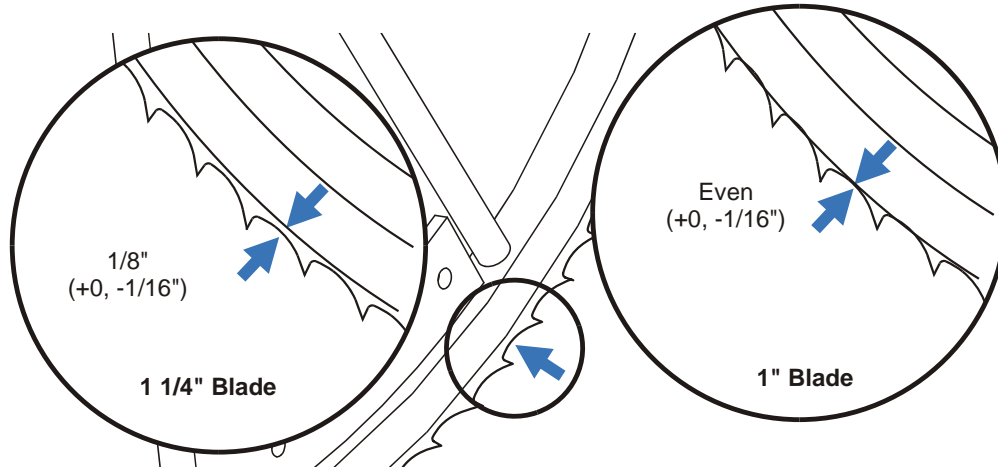

**FIG. 2-13**

3. If the blade is too far out on the idle side blade wheel turn the adjustment lever clockwise one quarter turn. If the blade is too far back on the idle side wheel, turn the lever counter-clockwise one quarter turn. Adjust blade tension if necessary. Spin wheels by hand and recheck blade position on wheels. Adjust the lever in quarter-turn increments until the blade is positioned correctly on the wheels.

See Figure 2-14.

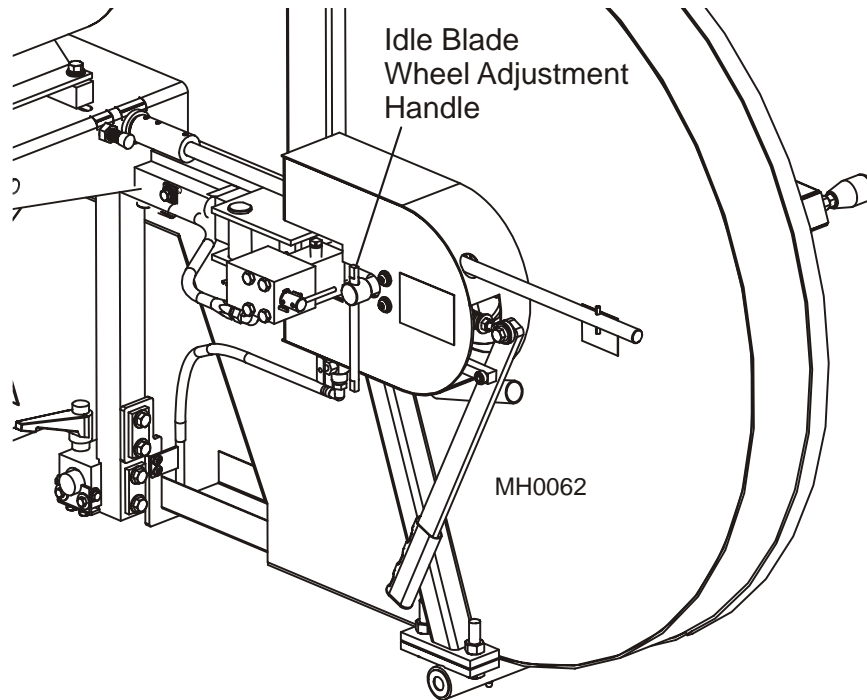

FIG. 2-14

4. After the blade is properly positioned on the blade wheels, you should check the position of the blade in relation to the blade guides. The back edge of the blade should be 1/16" (1.5 mm) from the flange of the blade guide rollers and back disks. [See Section 4.2](#) of this manual if adjustment of the blade guide rollers is required.
5. Close all blade housing covers and raise the perimeter fence.



**DANGER!** Make sure all guards and covers are in place and secured before operating MultiHead. Failure to do so may result in serious injury.

## 2.7 Saw Height Adjustment

You can raise or lower each individual saw head to determine the thickness of the finished stock. The saw heads should be adjusted so that the last blade the material passes through is closest to the feed track.

**Example:** You want to cut cants into 1/2" (12.5 mm) pallet material. Assuming your Multi-Head has six cutting heads, you will need to adjust each head in 9/16" (14.0 mm) increments up from the feed track. This will allow 1/16" (1.5 mm) kerf for each blade.

**See Figure 2-15.** The sixth saw head (last one the material will pass through) should be adjusted to 1/2" (12.5 mm) above the feed track. The fifth head should be adjusted to 1 1/16" (26.5 mm) above the track, fourth head 1 5/8" (40.5 mm), etc....

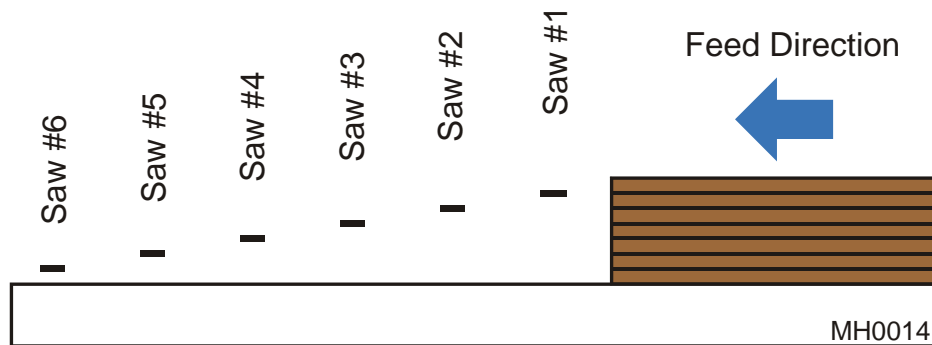
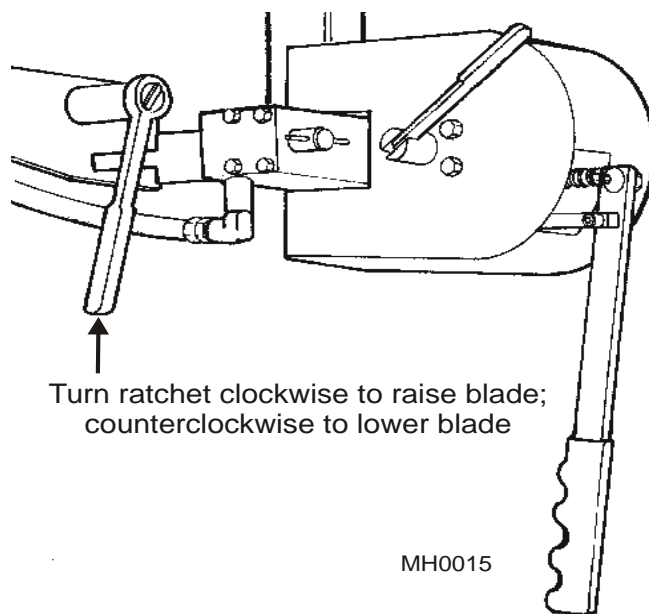

FIG. 2-15

## 2 Operation

### Saw Height Adjustment

See **Figure 2-16**. Use the up/down ratchet or crank handle to raise or lower each saw head. Turning the ratchet or crank clockwise will raise the saw head, counterclockwise will lower the saw head. The ratchet will only operate in one direction at a time. To change the direction of the ratchet, rotate the switch on the ratchet handle.



**FIG. 2-16 (SERIAL NO. 001- 188)**

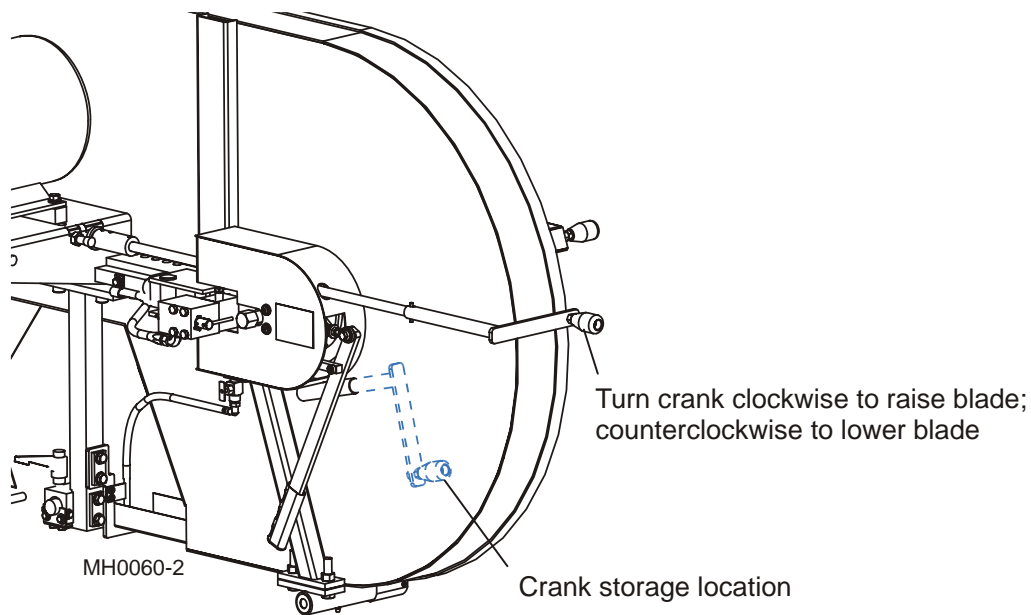
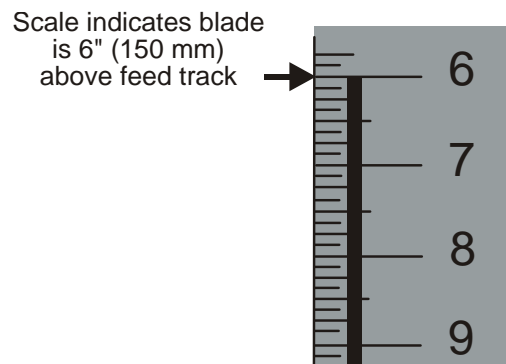

**FIG. 2-16 (SERIAL NO. 189+)**



**See Figure 2-17.** Raise or lower the saw head until the desired setting is obtained on the scale located on the vertical upright supporting the saw head.

**NOTE:** The scale should be used to approximate the location of the blade above the track. Belt thickness, blade kerf, and other variables will cause actual finished thicknesses to vary. You should run some test material through the saw and check the resulting material thickness. Adjust the saw heads up or down as necessary to obtain the desired finished thickness.



**FIG. 2-17**

## 2.8 Fence Adjustment

A fence is located at the infeed end of the MultiHead. The fence will help guide the cants straight down the track.

Before operating the MultiHead, you should adjust the fence for the width of material you will be cutting.

**Example:** If you are cutting 6" (150 mm) wide material, you should adjust the fence so it opens to a little over 6" (150 mm) from the inside wall of the track.

**See Figure 2-18.** Loosen the locking nuts and adjust the stop bolts so the fence stops at 6 1/4" (155 mm) from the inside wall.

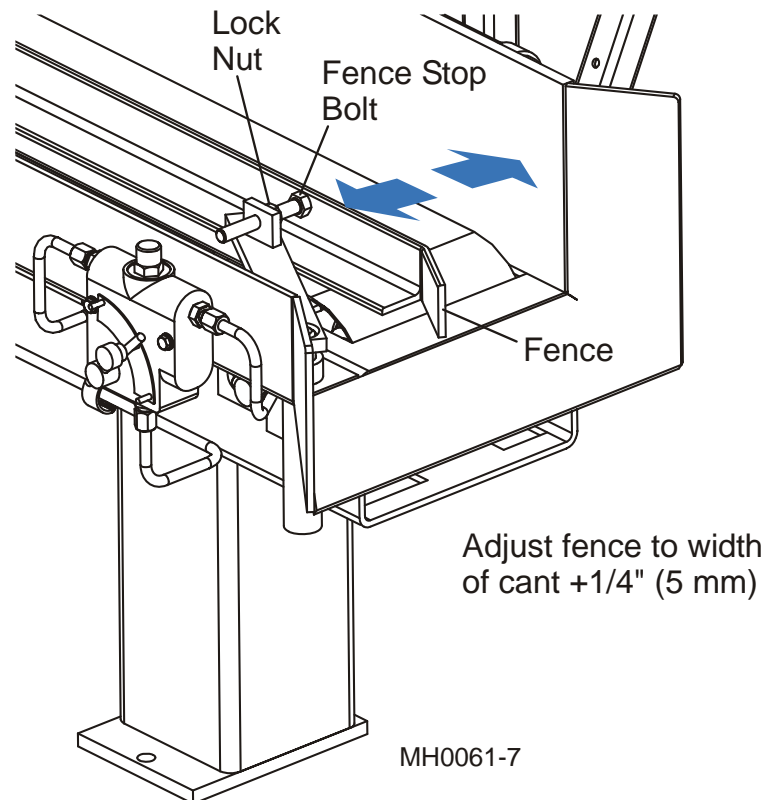

**FIG. 2-18**

## 2.9 Blade Guide Arm Adjustment

The outside blade guide arm can be adjusted in or out depending on the width of the material to be cut. The arm should be adjusted 1" (25 mm) wider than the material to be cut.

**Example:** If the material to be cut is 6" (150 mm) wide, adjust the blade guide arm so the area between the blade guides is 7" (175 mm) wide.

**See Figure 2-19.** The outer blade guide can be adjusted in or out 2" (50 mm) without disassembling the blade guide arm from the saw head. Simply loosen the mounting bolts and slide the arm in or out. Retighten the mounting bolts.

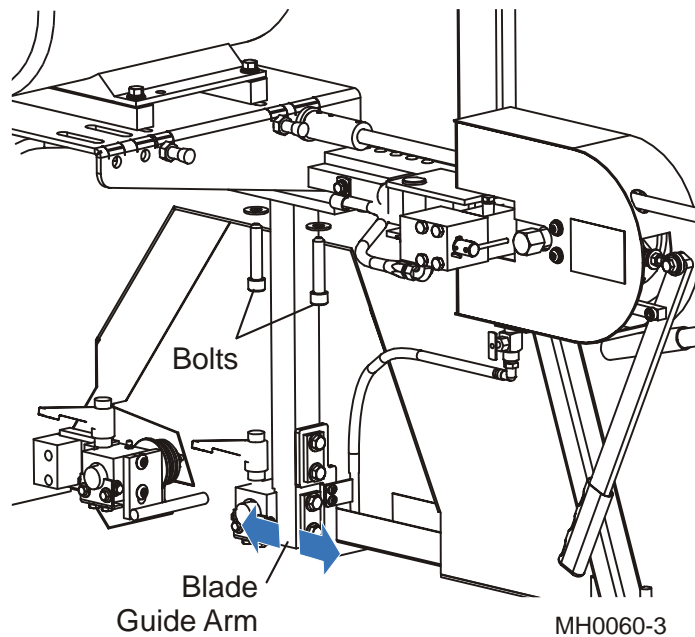

**FIG. 2-19**

**Example:** If the most common sizes you will saw are 4" (100 mm) and 6" (150 mm) you can mount the arm in a set of holes so when the arm is pushed all the way in against the mounting slots it is 5" (125 mm) from the inside guide. When you want to saw 6" (150 mm) material, loosen the mounting bolts and pull the blade guide arm all the way out against the mounting slots. The blade guide will now be 7" (175 mm) from the inside guide.

If the blade guide arm needs to be adjusted more than 2" (50 mm), remove the mounting bolts and move the blade guide arm to a different set of mounting holes. Replace the mounting bolts.

## 2.10 Machine Start



**DANGER!** Before starting the MultiHead, perform these steps to avoid injury and/or damage to the equipment:

- Close all blade covers and replace any guards removed for service.
- Check the feed track and remove all loose objects such as tools, wood, etc.
- Check that all blades are properly tensioned.
- Make sure all persons are clear and raise the perimeter fence to its upward position.
- Check that the emergency stops at both ends of the MutliHead are released.

**NOTE:** The MutliHead will not start if:

- There is not sufficient tension on the saw blades.
- The perimeter fence is not raised.
- The emergency stops at each end of the machine are not released.

Before starting the saw heads, check that the main power switch servicing the MultiHead is on.

## 6. Blade Drive



To start the blade motor, turn the key switch to the  position.

See **Figure 2-20**. Start each saw head motor beginning at the first saw head. Push the button labeled "1" on the saw start panel. The motor on the nearest saw head should start and the blade start spinning.

 **CAUTION!** Wait five (5) seconds between the start of each saw head motor to avoid high peak demand currents.

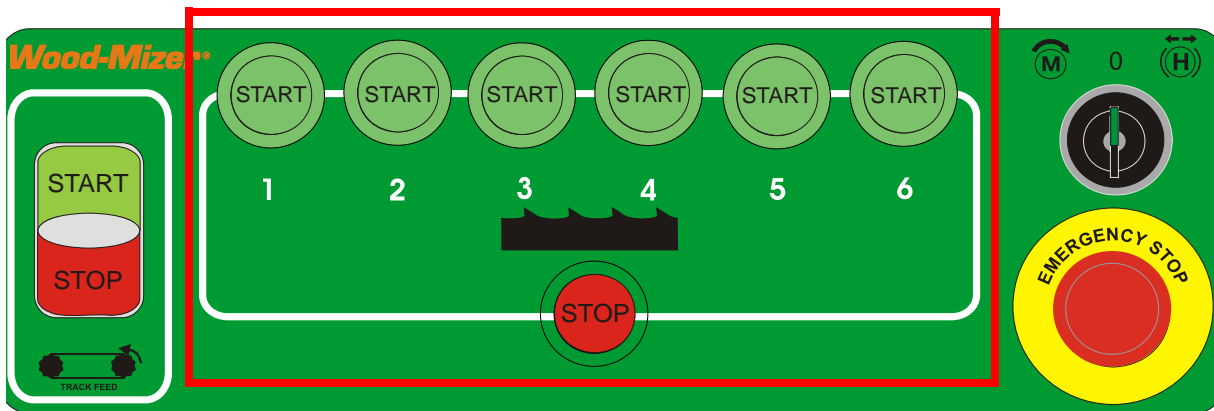

**FIG. 2-20**

Start the remaining saw head motors in succession (#2, #3...), waiting five seconds between starting each motor.

To stop the motors, push the emergency stop or the Blade/track Stop on the control panel. The saw motors also may be stopped by pushing the Emergency Stop button at the out-feed end of the resaw.

If either emergency stop is used to stop the saw head motors, rotate the switch clockwise to release the stop. The saw heads cannot be restarted until the EMERGENCY Stop is released.

See **Figure 2-21**. After at least one saw head has been successfully started, the feed track can be started. To start the feed track and feed rollers, turn the track feed switch on the control panel to the START position and release. The switch will return to the ON position and the track will start. The track can also be started in the same manner with the

## 2 Operation

### Machine Start

switch at the outfeed end of the resaw.

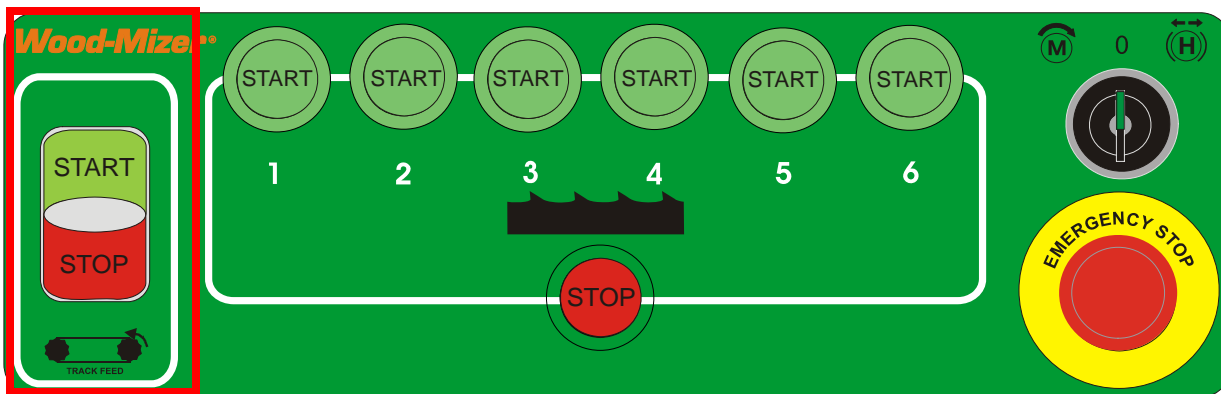

FIG. 2-21

The feed track can be stopped by pressing the blade/track stop button or the emergency stop on the control panel. The emergency stop at the outfeed end of the resaw will also stop the feed track. Either emergency stop button will shut down the saw head motors as well as the feed track.

If you just want to stop the track without stopping the saw blades, use the track feed switch on the control panel or at the outfeed end of the resaw. Turn the switch to the OFF position to stop the feed track.

**NOTE:** The track cannot be started from either control until the one used to stop the track is returned to ON. Once the track feed switch is returned to the ON position, the track can be started with either control.

**NOTE:** The track cannot be started until at least one saw head motor has been started.

**See Figure 2-22.** The speed at which the feed track moves is adjustable. The track feed rate valve allows the operator to adjust the feed rate from 0 to 100+ feet (30 m) per minute.

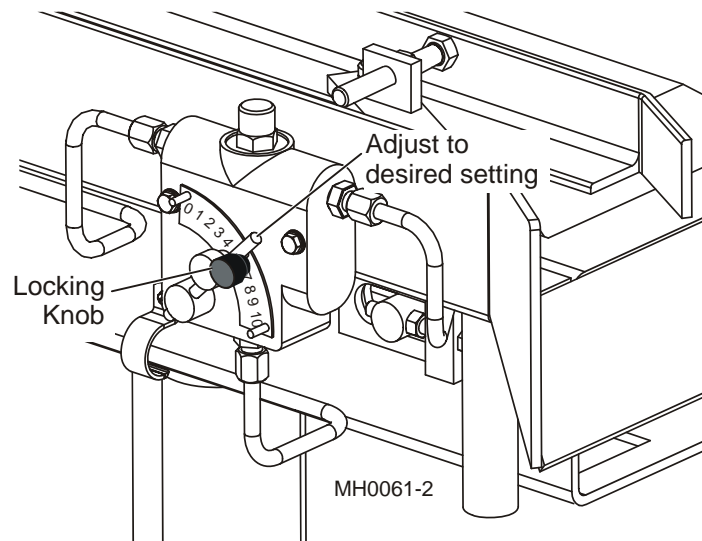

**FIG. 2-22**

To adjust the feed rate, turn the locking knob counterclockwise. Rotate the valve handle to the desired feed setting. Turn the locking knob clockwise to lock handle in position.

**Factors that will determine what feed rate you can use include:**

- Width of material to be cut. Eight-inch material will require a slower feed rate than 1" material.
- Hardness of material to be cut. Some woods that are seasoned or naturally very hard will require slower feed rates.
- Sharpness of blades. Dull or improperly sharpened blades will require slower feed rates than sharp and properly maintained blades.
- Off-bearing capability. Your ability to feed end-to-end will also determine what feed rate you can use.

### 2.11 Machine Shutdown

See **Figure 2-23**. If at any time you wish to stop the feed track during the operation, you can use the track feed switch on the control panel or at the outfeed end of the resaw. Turn the switch to the OFF position to stop the feed track. Restart the track by turning the switch to the START position. When you release the switch, it will return to the ON position and the track will start.

**NOTE:** The track cannot be restarted until the switch used to stop the track is returned to the ON position. Once the track feed switch is returned to ON, the track can be restarted from either control.

**NOTE:** The track cannot be started until at least one saw head motor is started.

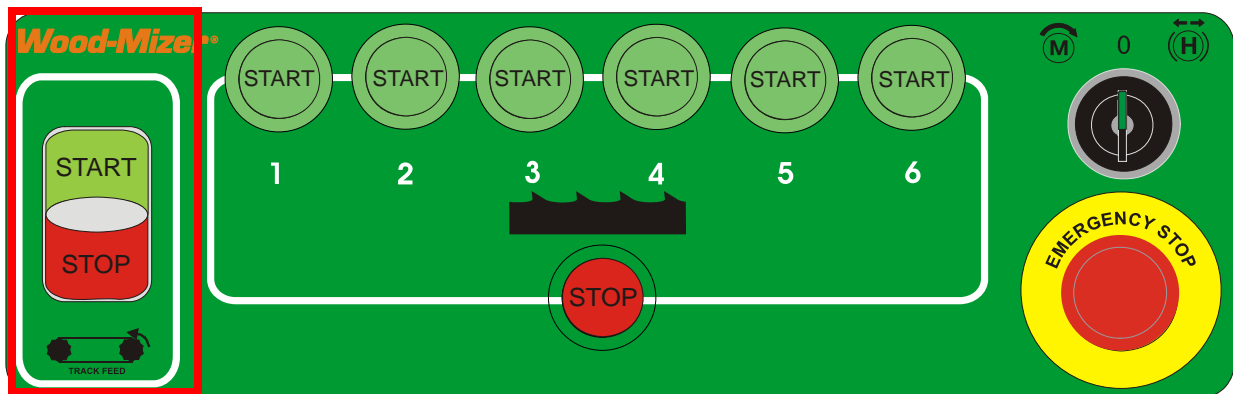

FIG. 2-23



See **Figure 2-24**. The feed track can also be stopped by pressing the emergency stop button on the control panel or at the outfeed end of the resaw. The emergency stop stops the saw blade motors as well as the feed track. Release the stop by turning the button clockwise. After the stop is released, the saw motors and track can be restarted.

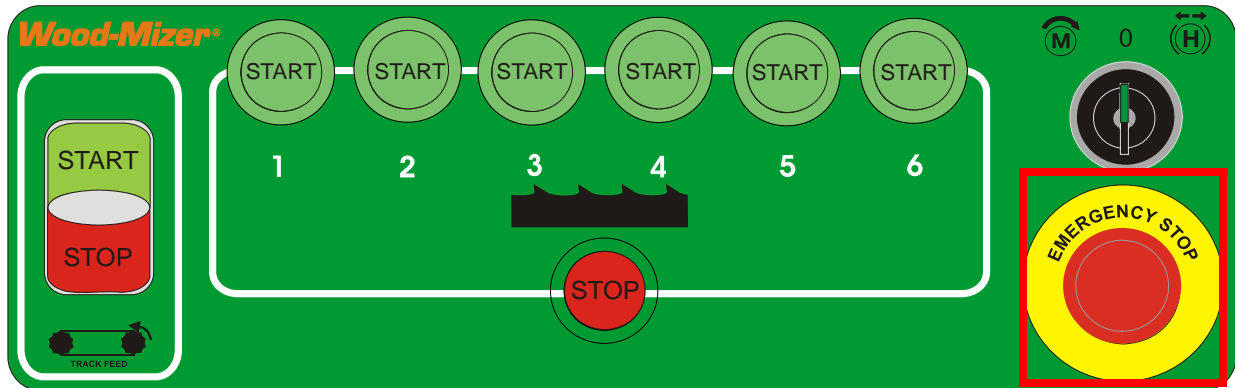

FIG. 2-24

See **Figure 2-25**. The feed track will also stop when the blade/track stop button on the control panel is pressed. The blade/track button stops all saw blade motors and the feed track. Restart the track with the track feed button as described above.

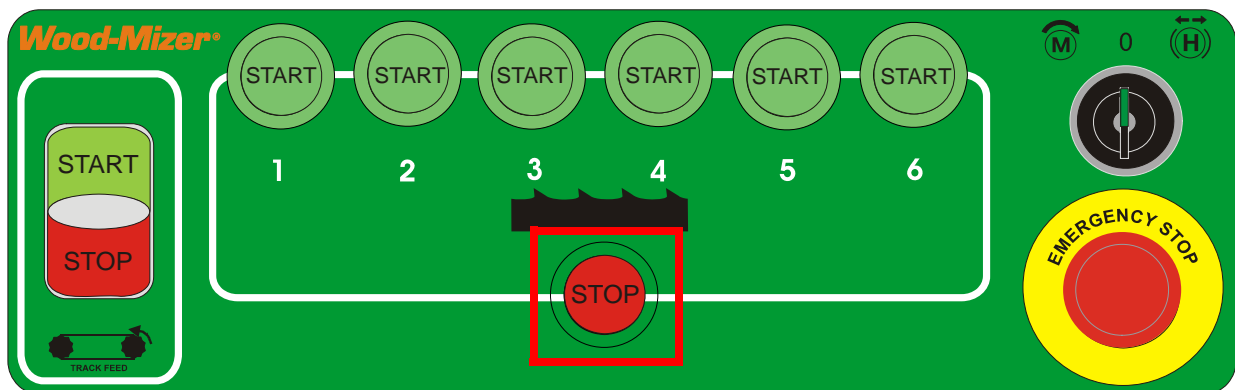

FIG. 2-25

The saw blade motors can be shut off with the blade/track stop button on the control panel. The emergency stop button on the control panel and at the outfeed end of the resaw will also stop all saw blade motors. Turn the emergency stop clockwise to release the stop and restart the saw blade motors with the saw start panel buttons on the control panel.

### 2.12 Operation Procedure

1. Install blades if necessary.



**WARNING!** Always wear gloves and eye protection when handling bandsaw blades. Changing blades is safest when done by one person! Keep all other persons away from area when coiling, carrying or changing a blade. Failure to do so may result in serious injury.

2. Close blade covers and raise perimeter fence.



**WARNING!** Allow blades to come to a complete stop before entering area protected by perimeter fence. Failure to do so will result in serious injury.

3. Tension blades to recommended setting.

4. Spin blade wheels by hand.



**WARNING!** Use extreme caution when spinning the blade wheels by hand. Make sure hands are clear of blade and wheel spokes before spinning. Failure to do so may result in serious injury.

5. Check alignment of blades on the blade wheels and blade guides. Adjust as necessary.

6. Raise or lower each saw head to desired setting.

7. Adjust fence to width of material to be cut.

8. Adjust blade guide arm to width of material to be cut.

9. Adjust feed rate valve setting to desired track speed.

10. Perform pre-start check.



**DANGER!** Make sure all guards and covers are in place and secured before operating MultiHead. Failure to do so may result in serious injury.

11. Start saw blade motors.



**DANGER!** Always be sure all persons are out of the path of the blade before starting the motor. Failure to do so will

result in serious injury.

 **WARNING!** Always wear eye, ear, respiration, and foot protection when operating or servicing the MultiHead.

 **CAUTION!** Wait five (5) seconds between start of each saw head motor to avoid high peak demand currents.

12. Place test material on feed track and start feed track.

 **DANGER!** Always be aware of and take proper protective measures against rotating shafts, pulleys, fans, etc. Always stay a safe distance from rotating members and make sure that loose clothing or long hair does not engage rotating members resulting in possible injury.

13. Allow test material to pass through all blades.

14. Shut off saw blades and feed track. Measure finished material and adjust saw heads up or down as necessary. Repeat with test material until desired finished dimension is obtained.

15. Restart saw blades and feed track.

16. Feed material into first feed roller. Return unfinished material to be re-fed into the resaw.

**NOTE:** See merry-go-round instructions, if operating Multi-Head equipped with merry-go-round handling system.

17. Monitor blade tension as operation continues. Adjust blade tension if required.

18. Stop all saw motors and feed track if material jam occurs. Lower perimeter fence to service machine or remove jammed material.

 **WARNING!** Allow blades to come to a complete stop before entering area protected by perimeter fence. Failure to do so will result in serious injury.

19. After operation is complete, shut off saw blade motors and feed track.

20. Release blade tension if done sawing for the day.

 **CAUTION!** Remove tension from the blades when the MultiHead is not in use.

## SECTION 3 MAINTENANCE

This section lists the maintenance procedures that need to be performed.

Routine and Periodic Maintenance Schedules are included. Keep track of machine maintenance by filling in the machine hours and the date you perform each procedure.



**This symbol** identifies the interval (hours of operation) which each maintenance procedure should be performed.

### 3.1 Blade Guides (Ceramic Disk/Roller)

This section applies to ceramic disk/roller style guides provided after Rev. A2.00. If you have block/roller guides, [See Section 3.2](#).



**WARNING!** Disconnect and lock out power supply before servicing the MultiHead! Failure to do so may result in serious injury.

Each MultiHead saw head has two blade guide assemblies that help the blade maintain a straight cut.

The two blade guide assemblies are positioned on the saw head and guide the blade on each side of the material being cut.

One blade guide assembly is mounted in a stationary position on the drive side of the saw head. This assembly is referred to as the "inner" or "drive" blade guide assembly.

The other blade guide assembly is mounted on the idle side of the saw head. It is referred to as the "outer" or "idle" assembly and is adjustable for various widths of materials to be processed.

**See Figure 3-1.** The outer blade guide assembly consists of a flanged roller positioned on top of the blade and a guide disk positioned against the bottom of the blade. The inner blade guide assembly consists of three guide disks, one on top of, one underneath and one behind the blade.

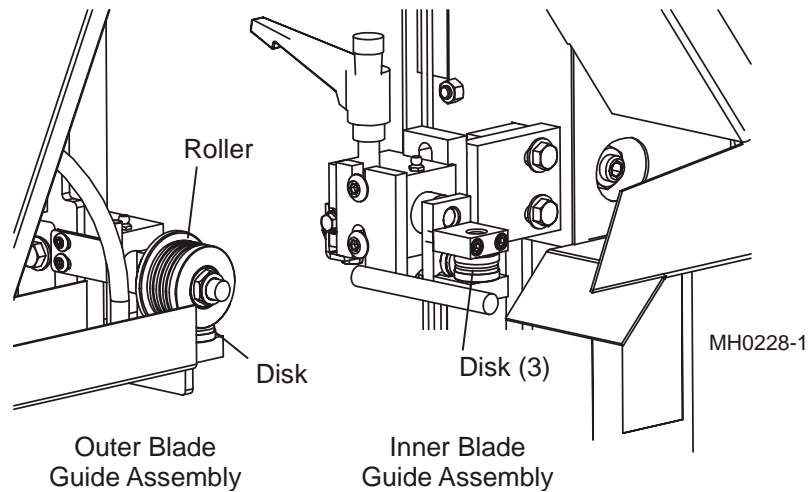

**FIG. 3-1**

All of the MultiHead blade guide assemblies have been pre-aligned at the factory. Proper blade guide alignment insures that properly sharpened and set blades will maintain a straight, accurate cut at the highest feed rates possible.

As you operate the MultiHead, the blade guides may move out of their factory alignment. If you experience sawing problems and have eliminated other causes such as dull blades, sap buildup, improper blade set, etc..., perform the Blade Guide Alignment ([See Section 4.3](#)).

### Blade Guide Inspection



Inspect the blade guide assemblies for proper alignment everytime you change the blade.



**WARNING!** Blade guide alignment is essential for optimal cutting performance, blade life and safety. Failure to check and maintain proper blade guide alignment will result in stress cracks forming in the blade. These cracks will lead to premature blade breakage. If the blade breaks during operation and the blade has multiple stress cracks, the blade could shatter into several pieces and escape from the protective guards of the machine. Small blade pieces projected into the area around the machine creates a safety hazard for the operator and any bystanders surrounding the machine.

1. Blow sawdust from both blade guide assemblies.
2. Before installing a new blade, inspect the guide disks. Disks that are chipped or damaged can be reused by honing them smooth with a diamond honing block (Wood-Mizer Part No. 017813).

**See Figure 3-1.** Remove the guide disk from the blade guide assembly and rub against the honing block using even, back-and-forth or circular strokes to smooth the disk surface. Use the honing block to smooth the sharp edges around the disk.

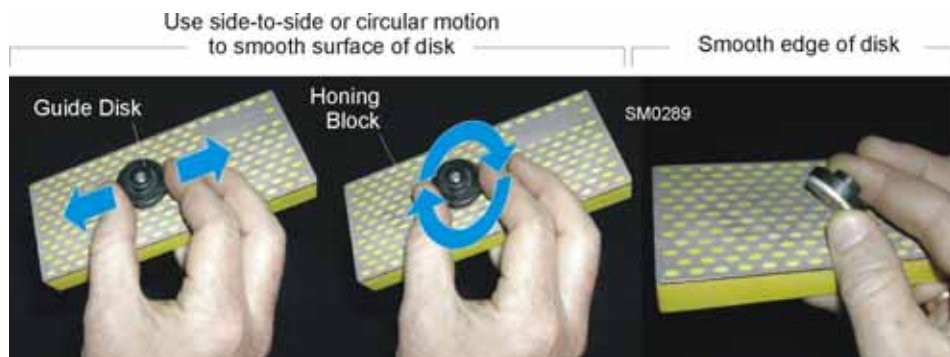

FIG. 3-1

If the guide disk is too damaged to reuse, replace with a new disk. New disks should be honed smooth before they are used to remove the rough surface created during the manufacturing process. Smooth the surface and edges of the disk as described above.

3. Check to see if the blade has worn a groove in the back disk of the inner blade guide assembly. If the disk is grooved, loosen the back disk mounting bolt and rotate the disk so the blade contacts an unworn section of the disk.

4. Check that the outer blade guide rollers spin freely. Rebuild or replace any roller that does not spin freely by hand.
5. If the blade to be installed is a previously used blade, inspect it for stress cracks.



**WARNING!** DO NOT use blades with stress cracks. Blades with stress cracks can shatter causing bodily injury and/or machine damage.

6. Install the blade and track it on the blade wheels ([See Section 2.6](#)).
7. Check that the rollers and bottom disks of the outer blade guide are properly spaced from the blade.

**See Figure 3-2.** Use the provided shim to check the space between the bottom disk and the blade (should be .008"). To adjust the bottom disk on the outer guide assembly, loosen the roller shaft nut and adjust the disk bracket up or down. Retighten the roller shaft nut.

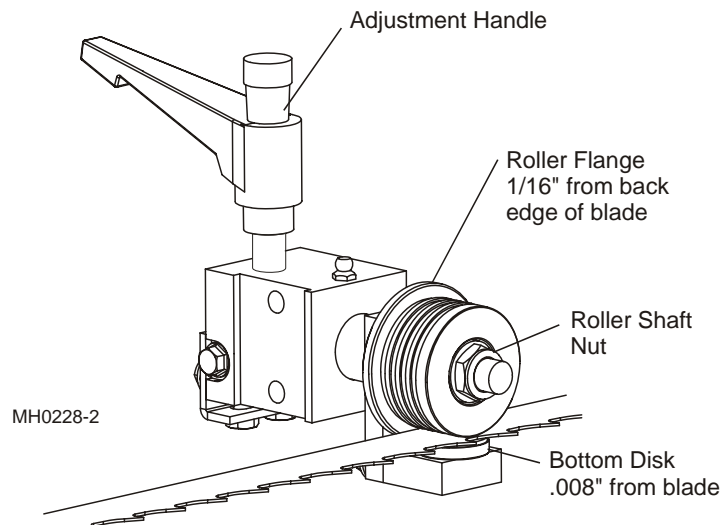
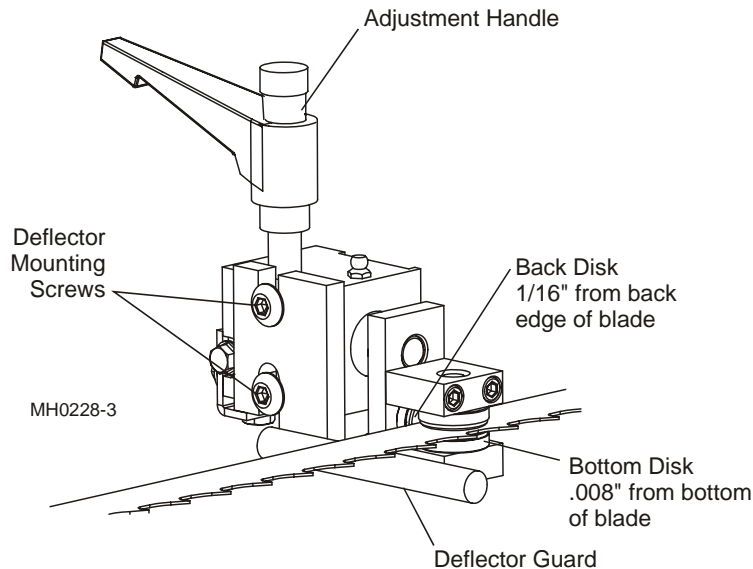

**FIG. 3-2**

Check the distance from the roller flange to the back of the blade. Loosen the adjustment handle and move the guide assembly until the flange is 1/16" from the blade if necessary.

8. Check that the disks of the inner blade guide are properly spaced from the blade.

**See Figure 3-3.** Use the provided shim to check the space between the bottom disk and the blade (should be  $.008''$ ). To adjust the bottom disk on the inner guide assembly, loosen the bottom disk mounting bolts and adjust the disk up or down. Retighten the mounting bolts.



**FIG. 3-3**

Check the distance from the back disk to the back edge of the blade. Loosen the adjustment handle and move the guide assembly so the back disk is  $1/16''$  from the blade if necessary.

9. Check that the deflector guard is close to, but does not touch the blade. Loosen the mounting screws and adjust up or down as necessary.



### ***Blade Guide Roller Rebuild***

The bearings in the blade guide rollers can be replaced several times during the life of the roller. To replace the bearings in a blade guide roller:

1. Remove the lock nut from the blade guide bolt.
2. Remove the blade guide roller, felt washers, and spacers from the bolt.
3. Use ring pliers to remove the bearing retainer ring from the roller housing.
4. Remove the two bearings from the roller housing and clean the housing with a petroleum product to remove old grease, sawdust, and dirt.
5. Insert two replacement bearings into the roller housing.
6. Install a retaining ring, felt washers, and spacers to the roller.
7. Reinstall the roller to the blade guide bolt.
8. Replace the lock nut to the blade guide bolt and tighten. Be careful not to overtighten.
9. Recheck blade guide alignment.

### ***Blade Guide Roller Replacement***

Replace the blade guide rollers when the grooves around the outer circumference become 1/16" deep or less. To replace, remove the lock nut, roller, felt washers, and spacers from the blade guide shaft. Install the new roller, felt washers, and spacers and replace the lock nut, being careful not to overtighten. Recheck blade guide alignment.

**Blade Guide Housing**

40

Grease the blade guide housings every 40 hours of operation.

See Figure 3-4.

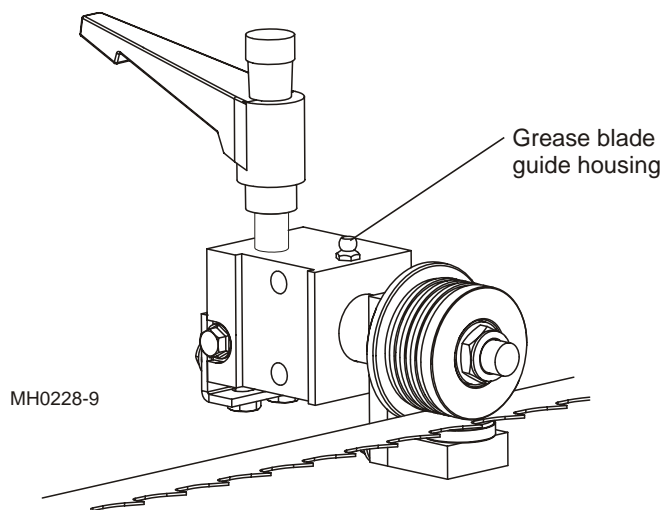

**FIG. 3-4**

## 3.2 Blade Guides (Block/Roller Guides)

This section applies to block/roller style guides provided before Rev. A2.00. If you have upgraded to ceramic disk/roller guides, [See Section 3.1](#).



**WARNING!** Disconnect and lock out power supply before servicing the MultiHead! Failure to do so may result in serious injury.

Each MultiHead saw head has two blade guide assemblies that help the blade maintain a straight cut.

The two blade guide assemblies are positioned on the saw head guide the blade on each side of the material being cut.

One blade guide assembly is mounted in a stationary position on the drive side of the saw head. This assembly is referred to as the "inner" or "drive" blade guide assembly.

The other blade guide assembly is mounted on the idle side of the saw head. It is referred to as the "outer" or "idle" assembly and is adjustable for various widths of materials to be processed.

**See Figure 3-5.** Each blade guide assembly consists of a flanged roller positioned on top of the blade and a guide block positioned against the bottom of the blade.

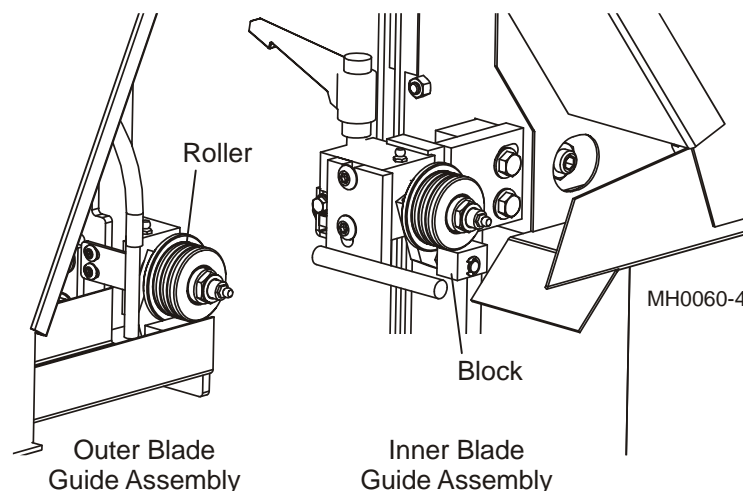

**FIG. 3-5**

All of the MultiHead blade guide assemblies have been pre-aligned at the factory. Proper blade guide alignment insures that properly sharpened and set blades will maintain a straight, accurate cut at the highest feed rates possible.

As you operate the MultiHead, the blade guides may move out of their factory alignment. If you experience sawing problems and have eliminated other causes such as dull blades, sap buildup, improper blade set, etc..., perform the Blade Guide Alignment ([See Section 4.2](#)).

### Blade Guide Inspection



Inspect the blade guide assemblies for proper alignment everytime you change the blade.

1. Blow sawdust from both blade guide assemblies.

See Figure 3-6.

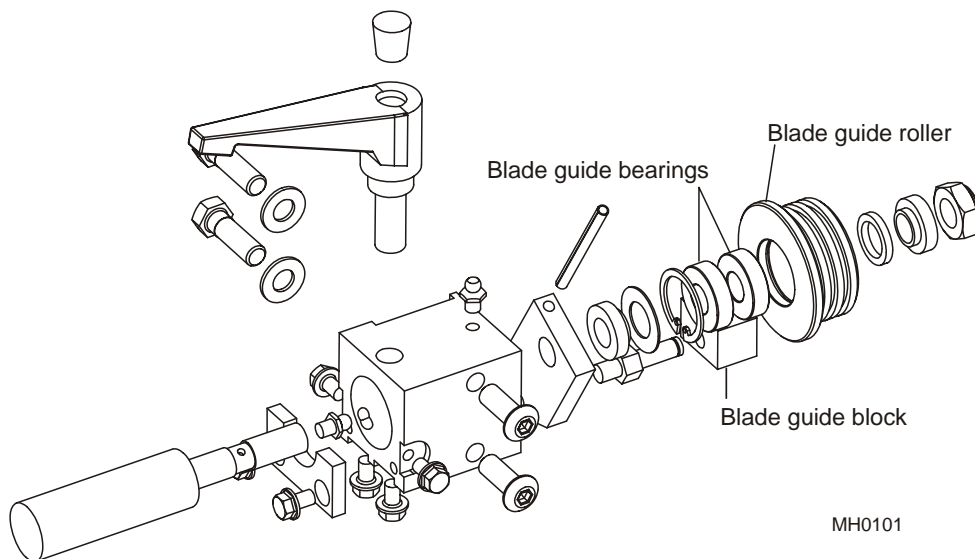

**FIG. 3-6**

2. Before installing a new blade, inspect the guide blocks. The blade guide blocks wear in a tapered pattern. Rotate each blade guide block every forty hours of operation to help the block wear evenly. To rotate, remove the O-ring holding the block to the pin. Remove the block, turn it 180°, and reinstall. Reinstall the O-ring. When the block wears down to the pin, replace it with a new block.
3. Check that the blade guide rollers spin freely. Rebuild or replace any roller that does not spin freely by hand.
4. Install the blade and track it on the blade wheels ([See Section 2.6](#)).

5. Loosen the adjustment handle and use the T-handle or pin handle to rotate the guide assembly away from the opposite guide assembly. Rotate the blade guide until the guide block is positioned firmly against the bottom of the blade. Do not turn the assembly so far that the guide block moves the blade up, away from the feed track.

 **CAUTION!** Be sure to rotate the blade guides in the correct direction. Rotate the guide assembly away from the feed track so that the guide block is furthest from the material to be fed into the blade. If the blade guides are rotated in the wrong direction, incoming material will damage the guide block and/or block mounting pin.

See Figure 3-7.

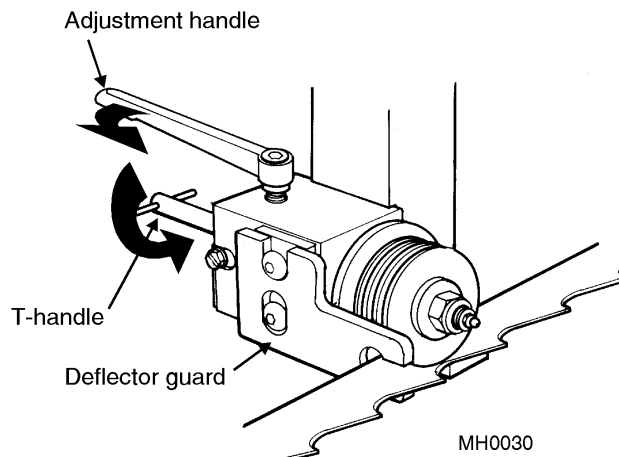

**FIG. 3-7 BLADE GUIDE WITH T-HANDLE SHAFT**

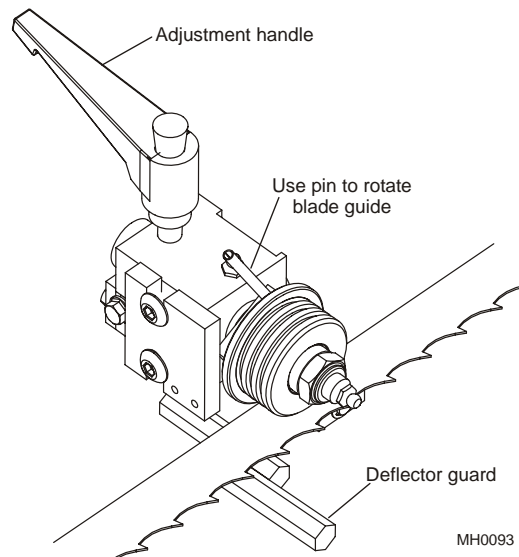

**FIG. 3-7 BLADE GUIDE WITH PIN HANDLE**

6. Before tightening the adjustment handle, check the distance between the blade guide roller flange and the back edge of the blade. Move the blade guide assembly in or out so the roller flange is  $1/16'' - 1/8''$  (1.5 - 3.0 mm) from the back of the blade.

See Figure 3-8.

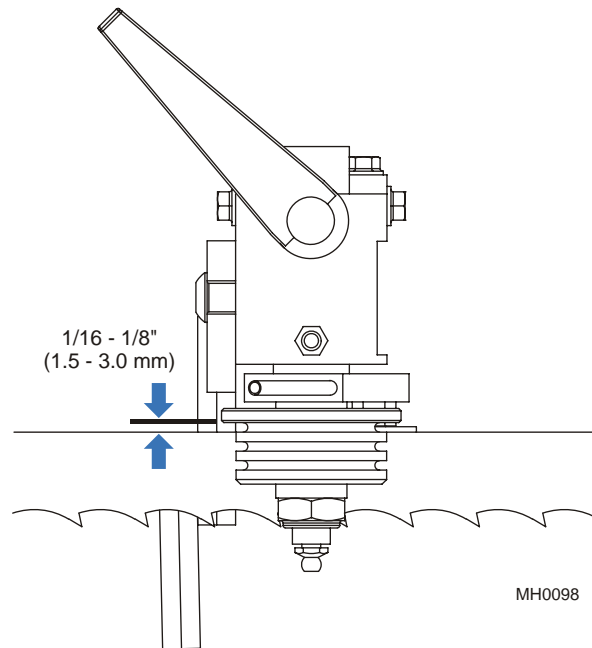

FIG. 3-8

**NOTE:** The distance from the back of the blade to the roller flange should be the same at the inside and outside blade guide assemblies.

7. Tighten the blade guide adjustment handle.
8. Check that the deflector guard ([shown in Figure 3-7](#)) does not touch the blade. Loosen the guard mounting bolts and adjust up or down as necessary.

### **Blade Guide Rebuild**

The bearings in the blade guides can be replaced several time during the life of the roller. To replace the bearings in a blade guide roller:

1. Remove the lock nut from the blade guide bolt.
2. Remove the blade guide roller, felt washers, and spacers from the bolt.
3. Use ring pliers to remove the bearing retainer ring from the roller housing.
4. Remove the two bearings from the roller housing and clean the housing with a petroleum product to remove old grease, sawdust, and dirt.
5. Insert two replacement bearings into the roller housing.
6. Install a retaining ring, felt washers, and spacers to the roller.
7. Reinstall the roller to the blade guide bolt.
8. Replace the lock nut to the blade guide bolt and tighten. Be careful not to overtighten.
9. Recheck blade guide alignment.

### **Blade Guide Replacement**

Replace the blade guide rollers when the grooves around the outer circumference become 1/16" deep or less. To replace, remove the lock nut, roller, felt washers, and spacers from the blade guide shaft. Install the new roller, felt washers, and spacers and replace the lock nut, being careful not to overtighten. Recheck blade guide alignment.



The blade guide blocks wear in a tapered pattern. Rotate each blade guide block every forty hours of operation to help the block wear evenly. To rotate, remove the O-ring holding the block to the pin. Remove the block, turn it 180°, and reinstall. Reinstall the O-ring. When the block wears down to the pin, replace it with a new block.

# 3 Maintenance

## Blade Guide Housing

### Blade Guide Housing

Grease the blade guide housings every 40 hours of operation.

40

See Figure 3-9.

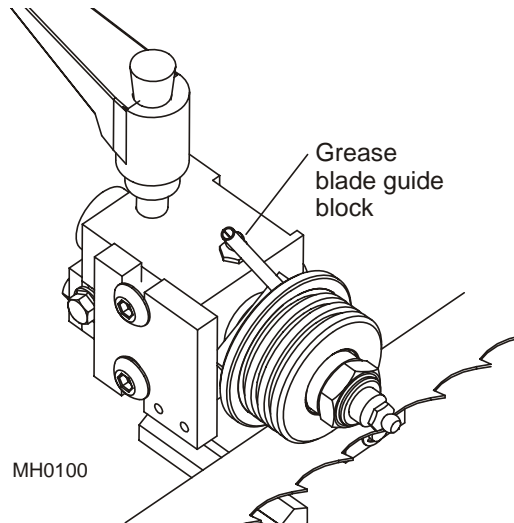

FIG. 3-9



### 3.3 Saw Head Up/Down Pad Adjustment

The saw heads slide up and down the mounting tubes on nylon pads assembled between the mounting tube and the saw head tube. If the fit between the tubes becomes so loose that the saw head vibrates excessively, the nylon pads can be adjusted.

1. Locate the four adjustment screws on the saw head tube behind the drive side blade pulley.

See Figure 3-10.

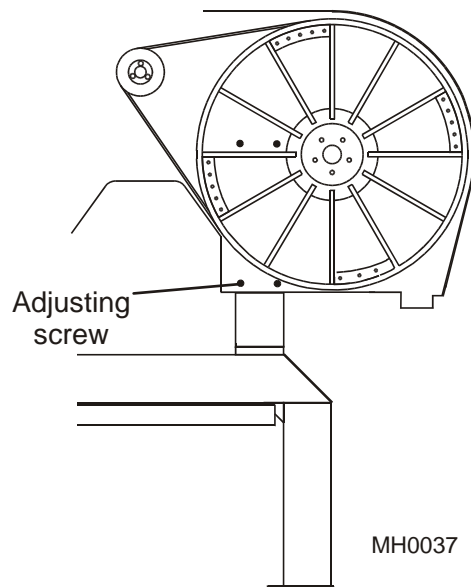

FIG. 3-10

2. Loosen the jam nuts at all four locations.
3. Turn each screw clockwise until it just bottoms out.
4. Recheck the fit of the saw head tube. Avoid adjusting the screws so tightly that the saw head becomes difficult to raise or lower. Adjust the screws in quarter-turn increments until the desired adjustment is obtained. Re-tighten jam nuts to maintain the adjustment.

### 3.4 Blade Height Indicator Adjustment

The blade height indicator on each saw head should indicate the distance from the bottom of the down-set teeth of the blade to the feed track. If the scale shows a different reading than the actual measurement from the down-set tooth to the track, loosen the locking set screw at the bottom of the indicator.

**See Figure 3-11.** Raise or lower the indicator until it indicates the actual measurement between the down-set tooth and feed track. Retighten the set screw.

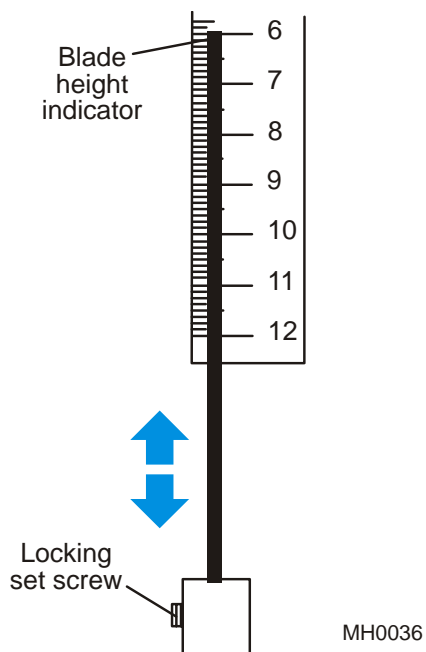

**FIG. 3-11**

### **3.5 Blade Tension Shutoff Switch Adjustment**

The blade tension shutoff switch shuts down the MutliHead if any of the blades break. The switch is adjusted at the factory to shutoff if the blade tension pressure falls below a certain level.

### 3.6 Blade Wheel Bearing Lubrication

750

**See Figure 3-12.** Lubricate the blade wheel hub bearings every 750 hours of operation with a high-quality synthetic grease such as Amoco Rycon #2 or Chevron SRI #2. To lubricate, follow these steps:

1. Remove the end seal from the hub cap.
2. Pump grease from a grease gun into the grease fitting until the new grease is seen exiting the hub bearings.
3. Replace the end seal.

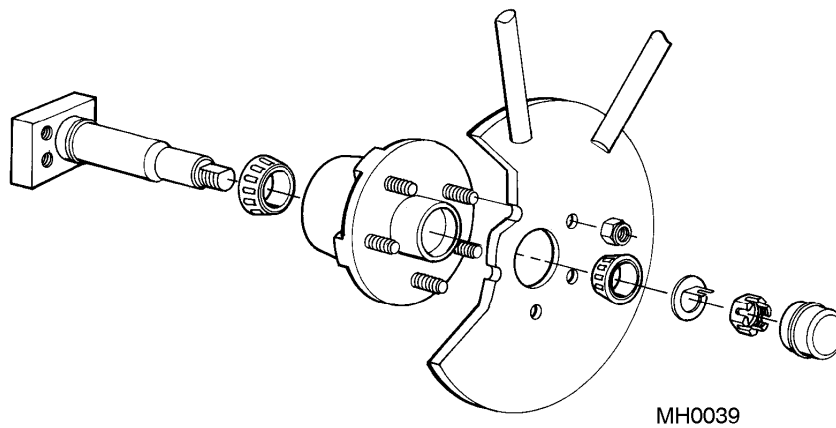

**FIG. 3-12**

### 3.7 Blade Wheel Belt Replacement



Inspect the belts around each blade wheel every forty hours of operation. Check that the belts are not worn to a point that a tensioned blade touches the metal wheel. Operating the MultiHead with worn blade wheel belts will lead to premature blade breakage. Replace the belts as necessary to prevent the blade from contacting the wheels.

### 3.8 Drive Belt Tension

8

Check the drive belt tension after the first half hour of operation, again after four hours of operation, and every eight hours of operation thereafter. The belt should have 7/16" (11 mm) deflection with 7 lbs. of deflection force.



**CAUTION!** Always keep proper tension on the drive belt. Keeping the drive belt too loose will ruin the belt.

**See Figure 3-13.** To adjust the belt, loosen the nuts on the four motor mount bolts. Locate the adjusting nuts underneath the motor. Turn the inside nuts clockwise down the threaded rod about 1/2" (13 mm). Turn the outside nuts until they are tight against the inside nuts. Recheck belt tension and adjust as necessary.

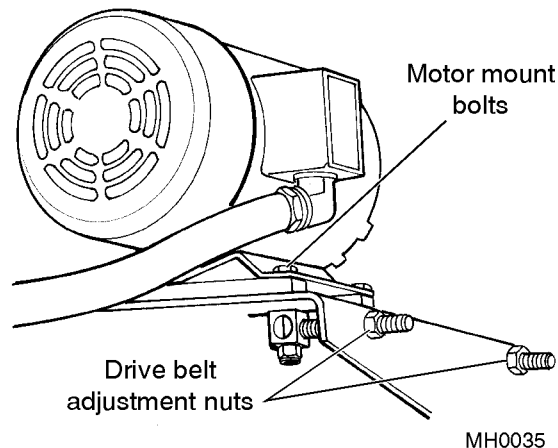

**FIG. 3-13**

### 3.9 Electric Motor Lubrication



The saw head and hydraulic pump motor bearings require lubrication once a year. One to two strokes of a medium consistency Polyurea-type grease from a grease gun is recommended.

### 3.10 Feed Roller Pivot Lubrication



A grease fitting is located at the pivot point of each feed roller assembly. Grease each feed roller pivot with lithium grease every forty hours of operation.

**NOTE:** When adjusting the drive belt tension, be sure to maintain the alignment of the motor perpendicular to the drive belt to prevent premature belt wear.



### 3.11 Feed Roller Assembly Rebuild

480

Check the feed roller assemblies for sprocket wear every 480 hours of operation. Each feed roller has individual sprockets which can be reassembled in a different order as necessary. If sprocket wear is affecting roller performance, rebuild the roller as follows. (Revisions 8/94+ only.) To rebuild:

1. Use the lift handle to access the roller.
2. Unbolt the sprocket retaining plate.
3. Remove the bolts, washers and plate.
4. Remove the sprockets and spacer rings from the shaft weldment and reinstall in the desired order.
5. Reinstall the retaining plate, washers and bolts.
6. Store the lift handle separate from the machine; do not leave the handle in the feed roller shaft.



## **Maintenance**

### *Feed Track Bearing Lubrication*

---

#### **3.12 Feed Track Bearing Lubrication**

The feed track bearings are greased at the factory and should not require regreasing during the life of the bearing.

### 3.13 Feed Tube Sawdust Removal

8

A rake is supplied that can be fitted to the MultiHead feed track to clear sawdust from the feed track tube. The rake should be used after every eight hours of operation.

1. Locate the modified link in the feed track. (It is shorter than the other links for easy identification.)
2. Raise the perimeter guard and restore power to the MultiHead.
3. Turn the feed track on until the modified link starts around the drive sprocket and the gap before the modified link is at its widest.

See Figure 3-14.

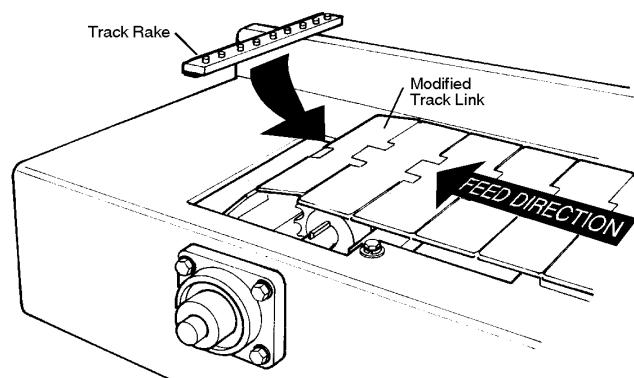

FIG. 3-14

4. Stop the feed track, lower the perimeter guard and slide the rake onto the modified link.
5. Raise all cutting heads so the rake will clear all blades and blade guides.
6. Raise the perimeter guard and turn the feed track on. The rake will travel through the feed tube and scrape sawdust out the end.
7. Stop the feed track just before the rake enters the drive end of the track tube.
8. Lower the perimeter guard and remove the track rake. DO NOT perform sawing operations until the rake is removed from the track.
9. Store the rake on the lip of the electrical junction box located at the drive end of the feed track.
10. Repeat use of the track rake after every eight hours of operation.

### 3.14 Hydraulic System Maintenance

- 40 **1.** Check the hydraulic tank fluid every forty hours of operation. The sight gauge on the tank should indicate a fluid level between LOW and HIGH. Add an all-season hydraulic fluid such as Exxon Unavis HVI 26 as needed to maintain proper fluid level.

If the fluid appears brown or cloudy, has an unusual 'burnt' odor, or if there is a sudden rise in oil temperature above 160°, completely drain the hydraulic tank and refill with new fluid. Also, remove and clean the suction strainer from the end of the hydraulic tank. Blow out any debris from the strainer and clean with a non-petroleum solvent before reinstalling to the tank.

- 40 **2.** Inspect the hydraulic lines and fittings for leaks every forty hours of operation or as fluid appears around the machine.

- 480 **3.** Replace the S28 cartridge filter on the back of the hydraulic fluid tank every 480 hours of operation.

- 2080 **4.** Completely drain the reservoir and refill with new fluid every 2080 hours of operation. Also, remove and clean the suction strainer from the end of the hydraulic tank. Blow out any debris from the strainer and clean with a non-petroleum solvent before reinstalling to the tank.

### 3.15 Perimeter Fence Pivot Lubrication



A grease fitting is located at each pivot point of the perimeter fence. Grease each pivot with lithium grease every forty hours.



## Maintenance

### *Saw Head Mounting Tube Lubrication*

---

#### 3.16 Saw Head Mounting Tube Lubrication



Lubricate the tube that each saw head travels up and down with Teflon every forty hours of operation.

### 3.17 Tension Assembly Lubrication



Apply dry graphite or a Teflon lubricant to the tension assembly and housing of each saw head every forty hours of operation.

### 3.18 Tensioner Screw Adjustment

A brass-tipped set screw is used to maintain a tight fit between the tensioner bar and its housing. If the tensioner fit becomes loose, the set screw should be tightened. To tighten:

1. Locate the tensioner set screw and loosen the jam nut.
2. Turn the set screw clockwise until tight, then back out 1/4 turn.
3. Re-tighten the jam nut.

**See Table 3-2.** The switch may need to be adjusted if the MutliHead does not shut off when a blade breaks or if different size blades are to be used.

Blade Used	Shutoff Switch Setting
.035" x 1"	1450 P.S.I.
.042" x 1"	1750 P.S.I.
.035" x 1 1/4"	1750 P.S.I.
.042" x 1 1/4"	2050 P.S.I.

**TABLE 3-2**

To adjust the shutoff switch:

1. Disconnect the incoming power supply to the MultiHead.
2. Install a blade to each saw head. Tension the blades to the recommended shutoff switch setting shown above.
3. Locate the shutoff switch under the blade tension gauge. Loosen the switch cover screw and remove the cover.



See Figure 3-15.

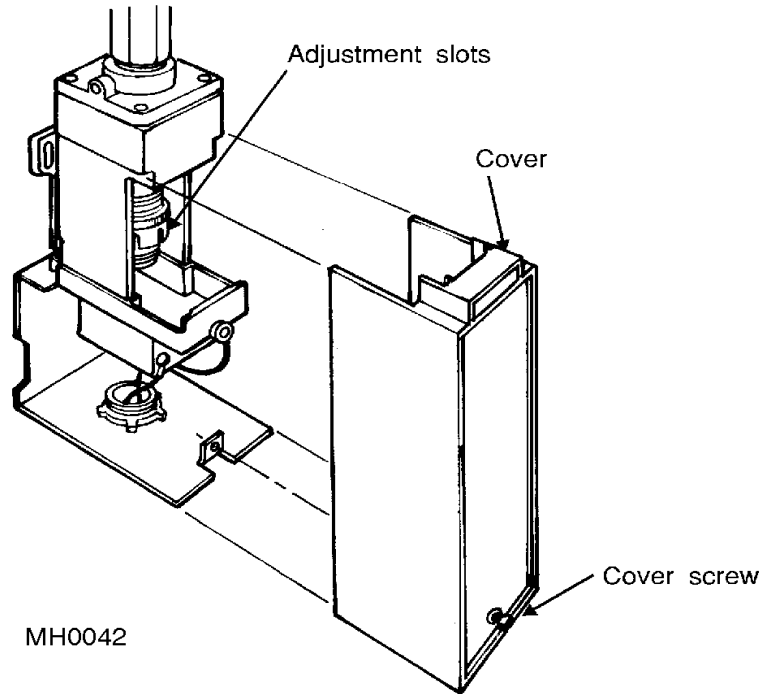

**FIG. 3-15**

4. Locate the adjustment dial slots. Use a flat screwdriver in the slots to pry the adjustment dial to the right (clockwise as viewed from bottom).
5. Turn the adjustment dial until the shutoff switch is activated (indicated by a "click" sound).
6. Replace the shutoff switch cover and tighten the cover screw.

### 3.19 Up/Down Drive Lubrication



The mechanism that raises and lowers each saw head includes a threaded drive rod located under the saw head motor. Apply a generous amount of Teflon lubricant to the threaded rod every forty hours of operation.

### 3.20 Routine Maintenance Schedule

**See Table 3-3.** The following table indicates recommended maintenance and lubrication intervals.

MAINTENANCE PROCEDURE	SECTION	8 HOURS	40 HOURS	480 HOURS	750 HOURS	2080 HOURS
Check Blade Guide Assemblies	3.1					
Drive Belt Tension (Check after first 1/2 hour, first 4 hours, and daily thereafter)	3.8					
Remove Feed Tube Sawdust	3.13					
Inspect Blade Wheel Belts	3.7					
Lubricate Feed Roller Pivots	3.10					
Inspect Hydraulic Fluid Level	3.14					
Inspect Hydraulic Lines and Fittings	3.14					
Lubricate Perimeter Fence Pivots	3.15					
Lubricate Saw Head Mounting Tube	3.16					
Lubricate Tensioner Assemblies	3.17					
Lubricate Up/Down Drive Rods	3.19					
Rebuild Feed Roller Assemblies	3.11					
Replace Hydraulic Fluid Filter	3.14					
Grease Blade Wheel Hub Bearings	3.6					
Lubricate Electric Motor Bearings	3.9					
Drain and Refill Hydraulic Tank Fluid	3.14					

**TABLE 3-3**

### 3.21 Periodic Maintenance

**See Table 3-4.** Good maintenance is essential to keep the MultiHead safe and in good operating condition. In addition to the routine maintenance listed above, periodic checks of the entire machine should be made.



**WARNING!** Disconnect and lock out power supply before servicing the MultiHead! Failure to do so may result in serious injury.

MAINTENANCE PROCEDURE	SECTION
Check Blade Height Indicator Reading	3.4
Check Blade Tension Shutoff Switch Adjustment	3.5
Check Saw Head Up/Down Pad Adjustment	3.3
Check Tensioner Screw Adjustment	3.18
Clear Sawdust From Blade Housings, Motors, Feed Track Sprocket, Feed Track Idle Roller, And All Moving Parts	3.13
Check Electrical Cords/Conduits And Hydraulic Hoses For Abrasion	--

**TABLE 3-4**

## 3.22 Electrical Problems

### *Head Will Not Start*

- Check main disconnect is on
- Check both emergency stops
- Check perimeter switch
- Check pressure switch
- Check fuses
- Check internal thermostats
- Check all phases are on

### *Cannot Start Track*

- Check at least one head is running
- Check other track switch
- Check fuses

### *Saw Starts Then Shuts Off*

- Check contactor (run or "Delta" contactor on Global models)

### *Saw Runs Then Shuts Off*

- Check timing relay (Global models only)
- Check motor temperature

Motors have internal thermostats that shut off motor when it gets too hot. Motor will automatically reset when cool and can then be restarted.

### *No Braking (Global models only)*

- Check fuse
- Check timer adjustment

# 3

## Maintenance

### *Troubleshooting Hints:*

---

- Check rectifier
- Check (Wye) contactor for short
- No Soft Start
- Check timer adjustment
- Check (Wye) contactor for short

### ***Troubleshooting Hints:***

Saw motor contactors are interchangeable. If you suspect a failed contactor, substitute one of the others as a check.

## SECTION 4 ALIGNMENT

### 4.1 Preliminary Alignment

Preliminary alignment is necessary to ensure enough adjustment will be available during final alignment.

If a blade has been installed to the saw head, remove it. Preliminary alignment should be performed without a blade installed.

1. Use the cant adjustment bolt to vertically tilt the wheel so that the top and bottom of each wheel is an even distance away from the back of the blade housing.

See Figure 4-1.

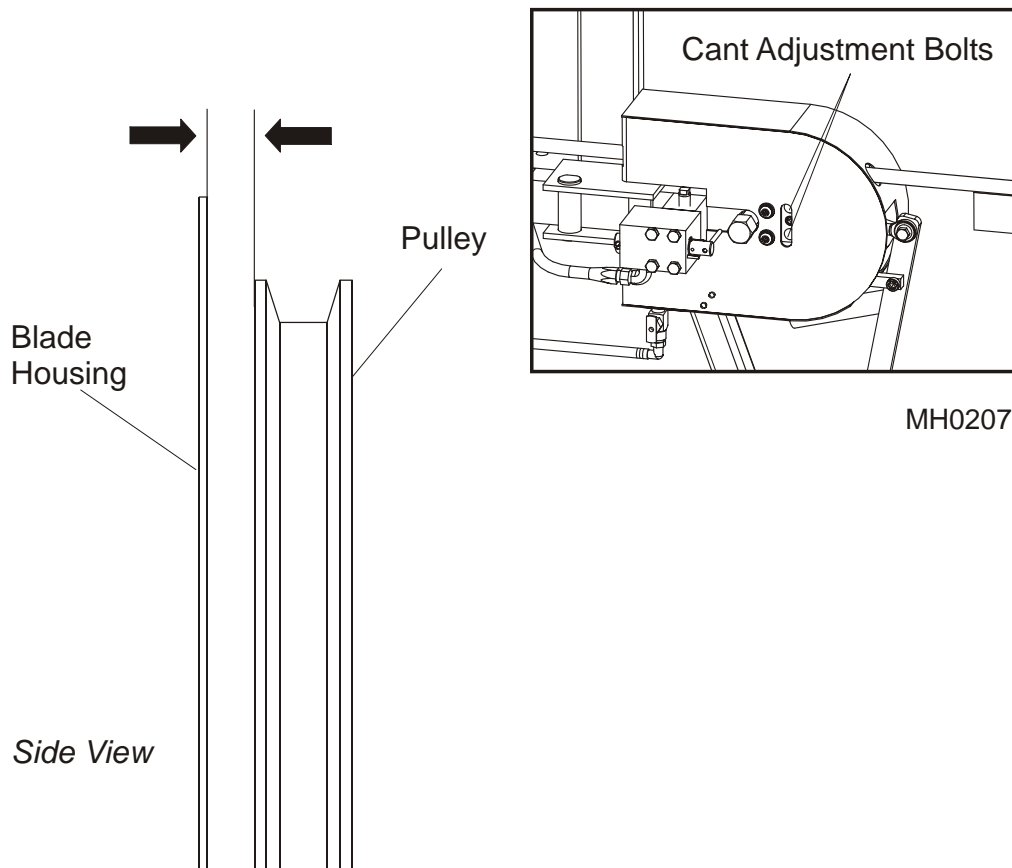

FIG. 4-1

# 4

## Alignment

### Preliminary Alignment

2. Use a digital level to align the wheels 90° to the track. If adjustment is needed, use the mounting and adjusting bolts at the base of the saw head mounting tube to move the mast forward or backward as needed.

See Figure 4-2.

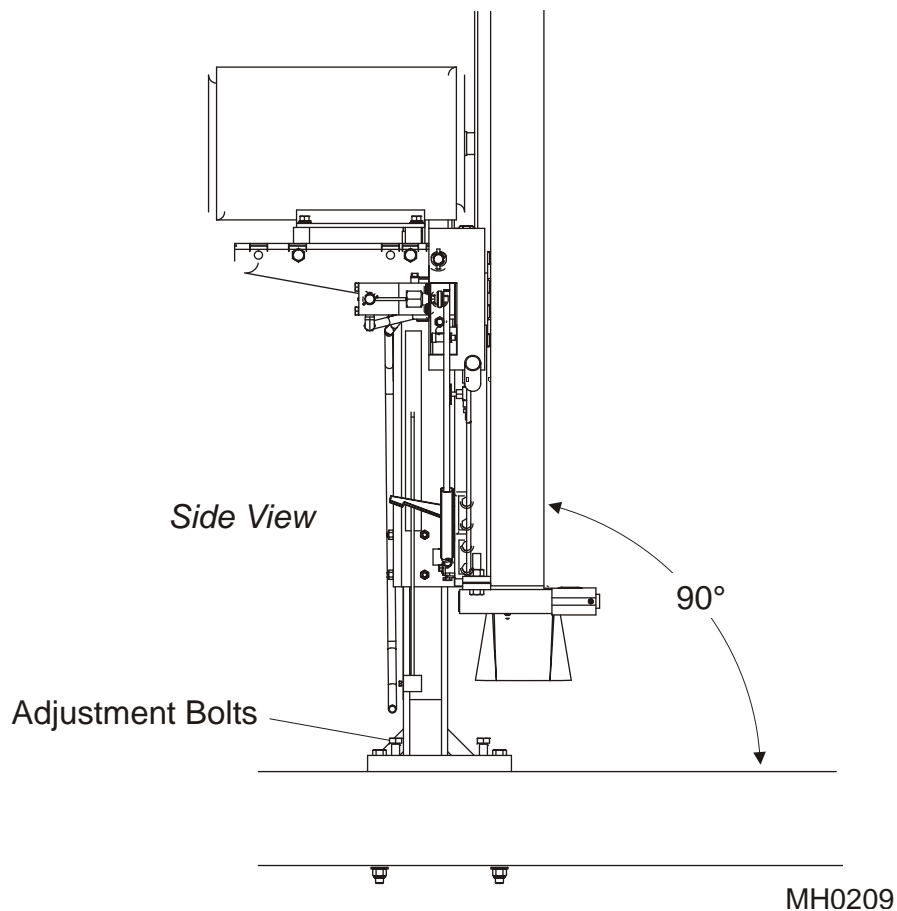
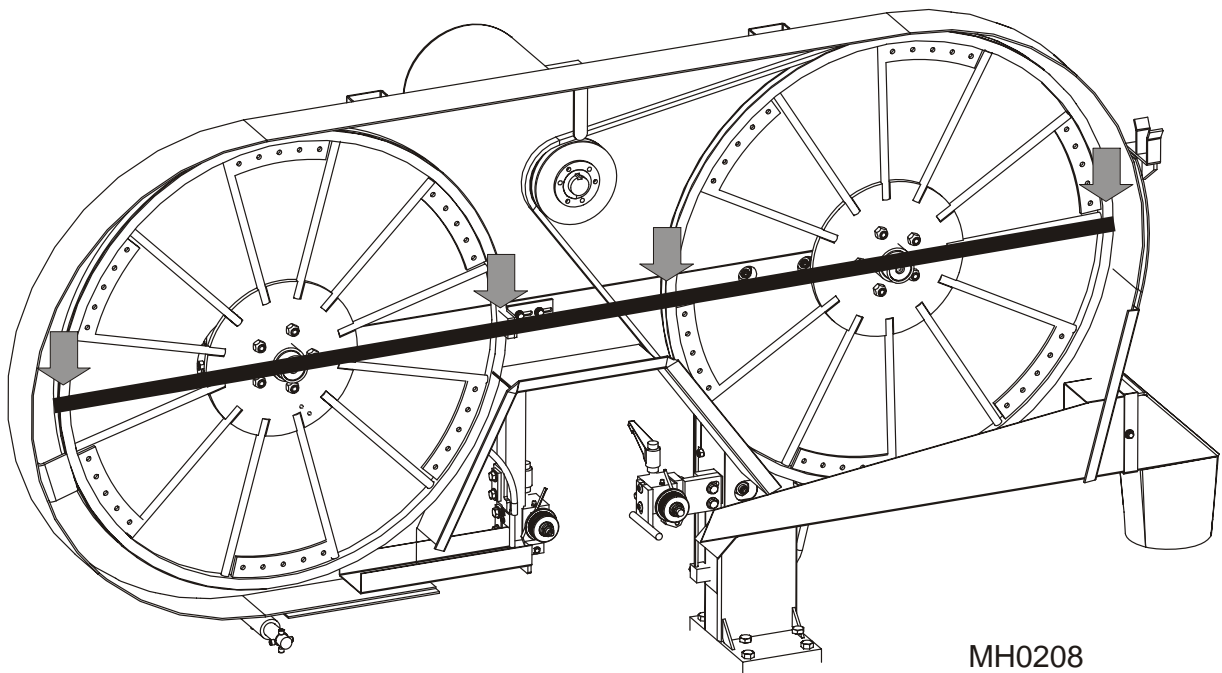

FIG. 4-2



3. Hold a straight edge or string across the midpoint of both blade wheels as shown in the following graphic.

**See Figure 4-3.** The straight edge should touch the outside edges of the wheels. If it does not touch, use the cant screws to adjust as necessary. To move the inside of the wheel out, tighten the cant screw. To move the inside of the wheel back, loosen the cant screw.



**FIG. 4-3**

## 4.2 Blade Guide Alignment (Block/Roller)

This section applies to block/roller style guides provided before Rev. A2.00. If you have upgraded to ceramic disk/roller guides, [See Section 4.3](#).

To reset factory blade guide alignment, follow the procedures listed in this section.



**WARNING!** Disconnect and lock out power supply before servicing the MultiHead! Failure to do so may result in serious injury.



**CAUTION!** Replace the blade wheel belts and the blade before realigning the blade guides. You cannot return the blade guides to their original factory-aligned positions using worn blade wheel belts.

### ***Saw Head Tilt Adjustment***

Install a blade to the saw head. [See Section 2.6](#).

After a blade has been properly installed to each saw head, the saw head must be tilted so the blade is parallel with the feed track. This will ensure square cuts and accurate dimensions across the width of the boards.

Screws are located at the base of each saw head which allow you to tilt the saw head side to side as well as back and forth.

1. Adjust the blade guides so that the rollers and blocks are not touching the blade.
2. Raise or lower the saw head so the blade is at an easy-to-measure distance from the track (e.g., 6" or 150 mm).

**See Figure 4-4.** Measure from the bottom of the blade to the track at the inside and the outside of the throat. If the two measurements are exactly equal or up to 1/32" (0.75 mm) higher on the outside, the blade is parallel to the feed track and no adjustment is necessary.

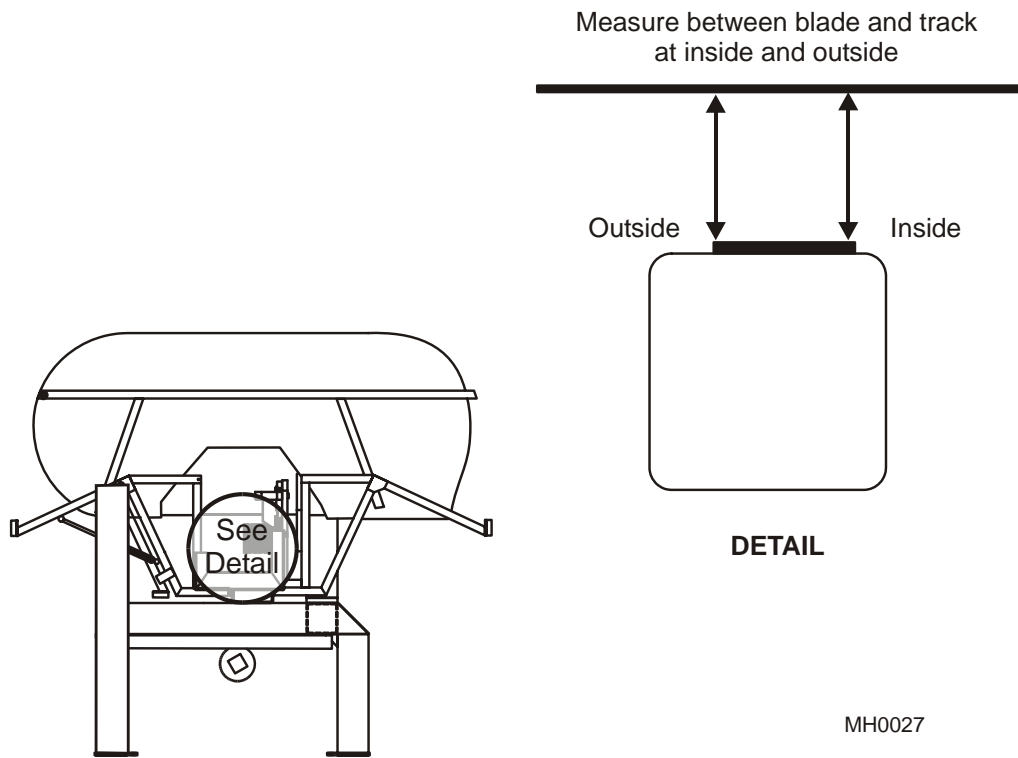

**FIG. 4-4**

3. If the outside dimension is less than the inside dimension, the outside of the saw head needs to be raised.

**See Figure 4-5.** Locate the mounting bolts and adjusting bolts at the base of the saw head mounting tube.

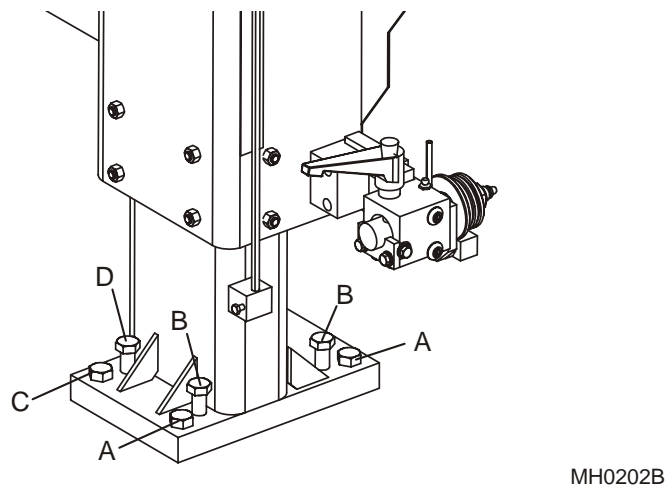

**FIG. 4-5**

# 4

## Alignment

### *Saw Head Tilt Adjustment*

---

#### **To raise the outside of the saw head:**

First check the current adjustment of the saw head tilt bolts. If the saw head mount plate is flat against the frame tube, use the inside set of bolts (A & B) to raise the outside of the saw head. If the outside adjustment bolts (C & D) are adjusted so they raise the mounting plate off the frame tube, use the outer set of bolts to raise the outside of the saw head.

Using the inside bolts (A & B) to raise the saw head:

1. Loosen the two inside mounting bolts 'A'.
2. Turn the adjusting bolts 'B' clockwise. Recheck the dimensions from the blade to the track.
3. Repeat adjustments until the blade measures 1/16" (1.5 mm) higher at the outside of the saw head. Then tighten mounting bolts 'A' until the outside measurement is exactly the same as or up to 1/32" (0.75 mm) higher than the inside measurement.

Using the outside bolts (C & D) to raise the saw head:

1. Turn the adjusting bolts 'D' counterclockwise.
2. Tighten the mounting bolts 'C' until the saw head mounting plate is flat against the frame tube.
3. Recheck the dimensions from the blade to the track.
4. If the outside of the saw head is still lower than the inside, use the inside set of adjustment bolts 'A' and 'B' to continue raising the outside of the saw head (See previous page).
5. If the outside of the saw head is higher than the inside, readjust the outside set of adjustment bolts to lower the outside of the saw head. Loosen the mounting bolts 'C' and turn the adjusting bolts 'D' clockwise.
6. Recheck the dimensions from the blade to the track.
7. Repeat adjustments until the blade measures 1/16" (1.5 mm) higher at the inside of the saw head. Then tighten mounting bolts 'C' until the inside measurement is exactly the same as or up to 1/32" (0.75 mm) lower than the outside measurement.
8. If the outside dimension is more than 1/32" (0.75 mm) higher than the inside dimension, the outside of the saw head needs to be lowered.

**To lower the outside of the saw head:**

First check the current adjustment of the saw head tilt bolts. If the saw head mount plate is flat against the frame tube, use the outside set of bolts (C & D) to lower the outside of the saw head. If the inside adjustment bolts (A & B) are adjusted so they raise the mounting plate off the frame tube, use the inside set of bolts to lower the outside of the saw head.

Using the outside bolts (C & D) to lower the saw head:

1. Loosen the two outside mounting bolts 'C'.
2. Turn the adjusting bolts 'D' counterclockwise. Recheck the dimensions from the blade to the track.
3. Repeat adjustments until the blade measures the same distance from the track at the outside and inside of the saw head. Then tighten mounting bolts 'C', making sure the outside measurement remains exactly the same as or up to 1/32" (0.75 mm) higher than the inside measurement.

Using the inside bolts (A & B) to lower the saw head:

1. Turn the adjusting bolts 'A' counterclockwise.
2. Tighten the mounting bolts 'B' until the saw head mounting plate is flat against the frame tube.
3. Recheck the dimensions from the blade to the track.
4. If the outside of the saw head is still higher than the inside, use the outside set of adjustment bolts 'C' and 'D' to continue lowering the outside of the saw head (See previous page).
5. If the outside of the saw head is lower than the inside, readjust the inside set of adjustment bolts to raise the outside of the saw head. Loosen the mounting bolts 'A' and turn the adjusting bolts 'B' clockwise.
6. Recheck the dimensions from the blade to the track.
7. Repeat adjustments until the blade measures 1/16" (1.5 mm) higher at the outside of the saw head. Then tighten mounting bolts 'A' until the inside measurement is exactly the same as or up to 1/32" (0.75 mm) lower than the outside measurement.

# 4

## Alignment

### *Prepare Blade Guides For Alignment*

---

#### ***Prepare Blade Guides For Alignment***

1. Remove the deflector guard from the inner blade guide assembly to allow easier viewing of guide assembly.
2. Install new blade wheel belts and a new blade. Tension the blade and track it on the wheels.
3. Rotate both blade guide assemblies. Loosen the blade guide adjustment handle and rotate the blade guide assembly so the guide block is positioned directly under the guide roller.
4. Raise both blade guide assemblies. Loosen the blade guide mounting bolts and move the assembly up so the roller is 1/16" (1.5 mm) from the blade.
5. Check the saw head alignment as described earlier.

#### ***Blade Guide Side-To-Side Tilt Alignment***

**See Figure 4-6.** Check the side-to-side tilt of the inner blade guide:

1. Loosen the adjustment handle and move the blade guide forward or back until the roller flange is 1/16" - 1/8" (1.5 - 3.0 mm) from the back edge of the blade.

**NOTE:** Once you have adjusted one blade guide, adjust the second blade guide the same. For example, if you adjusted the inner blade guide with 1/8" gap between the blade and the roller flange, adjust the outer blade guide to 1/8" gap.

2. Rotate the guide block away from the outer blade guide assembly. Rotate until the block

pushes the blade firmly against the roller. Tighten the adjustment handle.

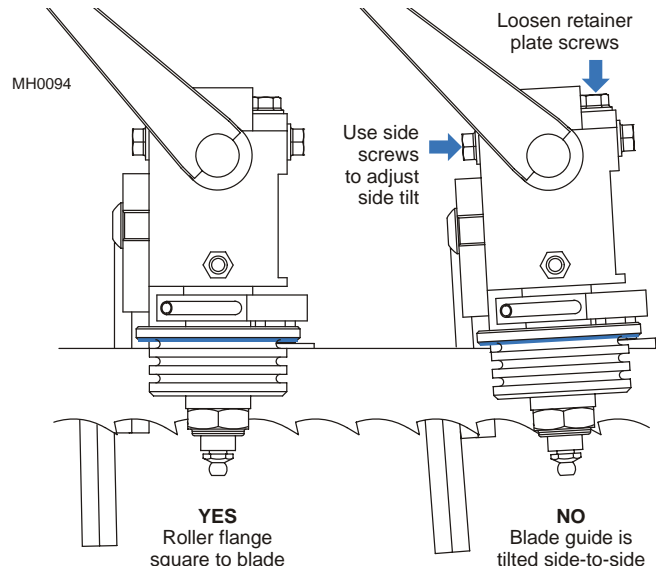

FIG. 4-6

3. Slowly turn the blade wheels counterclockwise by hand until the blade makes two complete revolutions and the blade weld is positioned between the top of the two blade wheels.



**WARNING!** Use extreme caution when turning the blade wheels by hand. Keep hands clear of blade and wheel spokes while turning. Failure to do so may result in serious injury.

4. Check the gap between the guide roller flange and the back of the blade. If the gap is the same as before you spun the blade, no adjustment is necessary.
5. If the gap between the roller flange and the blade is not the same, adjust the side-to-side tilt.
  - Loosen the two retainer plate bolts at the rear of the blade guide assembly.
  - Loosen one side adjustment bolt and tighten the other to tilt the blade guide in the direction necessary.
  - Repeat steps 1-5 until the gap between the roller flange and the back of the blade is the same before and after you spin the blade.
6. Retighten the two retainer plate bolts. Perform the vertical tilt adjustment for the inner blade guide assembly.

**Blade Guide Vertical Tilt Alignment**

See **Figure 4-7**. Use the blade guide alignment tool to check the vertical tilt of the inner blade guide:

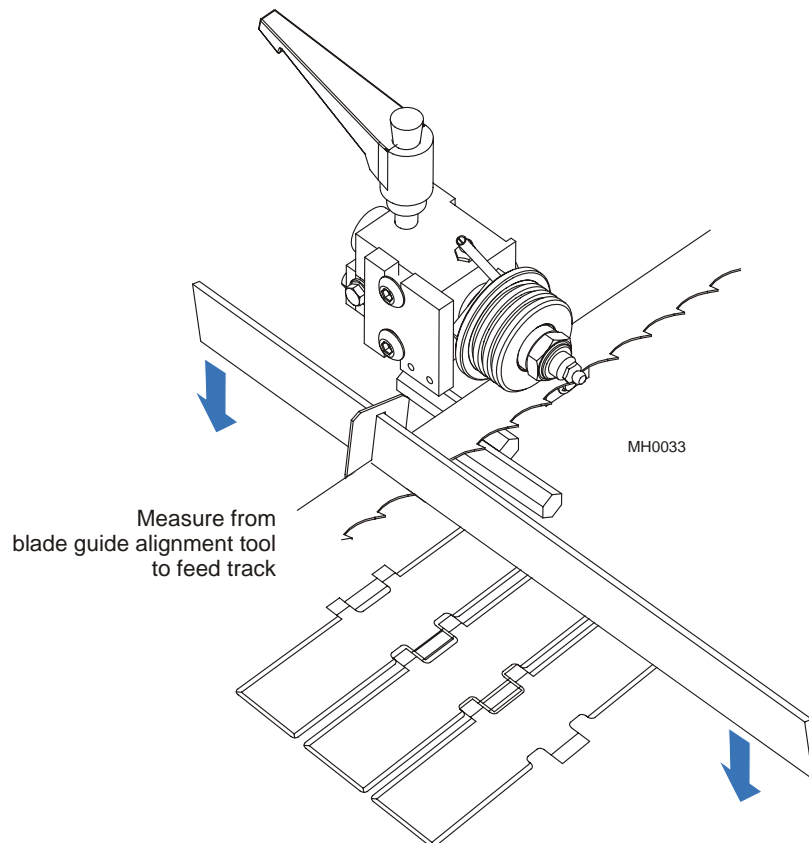
**FIG. 4-7**

1. Clip the blade guide alignment tool to the blade near a blade guide assembly. Make sure the tool does not rest on a tooth or a burr. The tool should rest flat on the body of the blade.
2. Measure the distance from the bottom edge of the tool to the feed track at the front end of the tool.
3. Measure the distance from the bottom edge of the tool to the feed track at the rear of the tool.

If the measurements at the front and rear of the tool are the same ( $\pm 1/32$ " [0.8 mm]), the blade is not tilted and adjustment is not necessary.

If the measurement at the front of the tool is larger than the measurement at the rear of the tool, the blade guide is tilted up.



**See Figure 4-8. To tilt the blade guide down:**

- Loosen the two retaining plate bolts at the rear of the blade guide assembly.

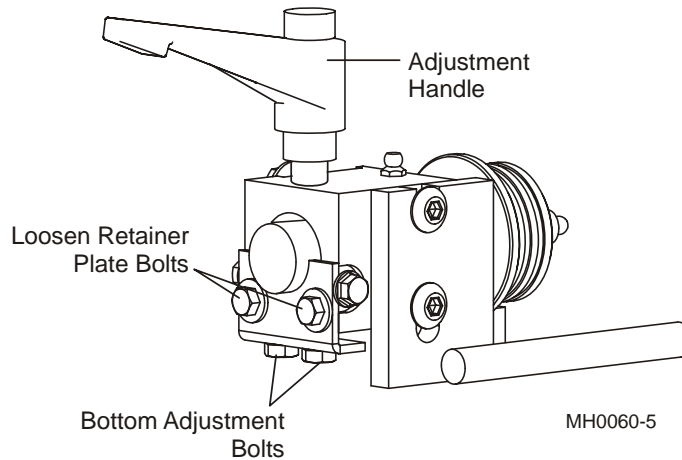

**FIG. 4-8**

- Loosen the adjustment handle and tighten the two bottom adjustment bolts.
- Rotate the guide block against the blade and retighten the adjustment handle and retainer plate bolts.
- Recheck vertical tilt and repeat adjustments as necessary.

If the measurement at the rear of the tool is larger than the measurement at the front of the tool, the blade guide is tilted down.

**To tilt the blade guide up:**

- Loosen the two retainer plate bolts at the rear of the blade guide assembly.
  - Loosen the bottom adjustment bolts. Rotate the guide block against the blade and tighten the adjustment handle. Adjust until the tool is level with the feed track ( $\pm 1/32$ " [0.8 mm]).
  - Retighten the adjustment bolts and the retainer plate bolts.
  - Recheck vertical tilt and repeat adjustments as necessary.
4. After the inner blade guide assembly is adjusted properly, rotate the assembly so that the block is positioned directly below the roller.
  5. Repeat side-to-side and vertical tilt adjustments for the outer blade guide assembly.

***Final Blade Guide Alignment Procedures***

1. Make sure the rollers and blocks are not touching the blade.
2. Measure from the track to the bottom of the blade.
3. Loosen the inner blade guide assembly mounting bolts and adjust the assembly down so the roller deflects the blade 1/16" (1.5 mm) toward the feed track. Retighten the inner blade guide mounting bolts.
4. Loosen the outer blade guide assembly mounting bolts and adjust the assembly down so the blade measures the same distance from the feed track at the outer blade guide as the inner blade guide (+1/64 [0.4 mm], -0). Retighten the outer blade guide mounting bolts.
5. Rotate each blade guide assembly so the guide block is positioned firmly against the blade. Be sure to maintain the spacing between the roller flange and the back of the blade.

**NOTE:** Rotate the guide block against the blade firmly enough so the blade guide roller spins when the blade spins but the blade does not spin when you turn the blade guide roller by hand.

6. Retighten both adjustment handles.
7. Slowly turn the blade wheels by hand so that the blade makes a few complete revolutions.



**WARNING!** Use extreme caution when turning the blade wheels by hand. Keep hands clear of blade and wheel spokes while turning. Failure to do so may result in serious injury.

8. Stop the blade so that the blade weld is positioned between the top of both blade wheels.
9. Reinstall the blade deflector so it is flush to 1/16" behind the track fence.
10. Recheck blade deflector clearance and guide roller flange spacing at each guide assembly.
11. Tighten all screws to secure.

### 4.3 Blade Guide Alignment (Ceramic Disk/Roller)

This section applies to ceramic disk/roller style guides provided after Rev. A2.00. If you have block/roller guides, [See Section 4.2.](#)

To reset factory blade guide alignment, follow the procedures listed in this section.



**WARNING!** Disconnect and lock out power supply before servicing the MultiHead! Failure to do so may result in serious injury.



**CAUTION!** Replace the blade wheel belts and the blade before realigning the blade guides. You cannot return the blade guides to their original factory-aligned positions using worn blade wheel belts.

#### *Prepare Blade Guides For Alignment*

1. Remove the deflector guard from the inner blade guide assembly to allow easier viewing of guide assembly.
2. Install new blade wheel belts and a new blade. Tension the blade and track it on the wheels ([See Section 2.6](#)).
3. Inspect the blade rollers and disks as described in the Maintenance section ([See Section 3.1](#)). Repair or replace rollers or disks as directed.
4. Loosen the inner blade guide mounting bolts and move the assembly down until the top disk touches the top of the blade. Retighten the mounting bolts.

# 4

## Alignment

### Prepare Blade Guides For Alignment

See Figure 4-9.

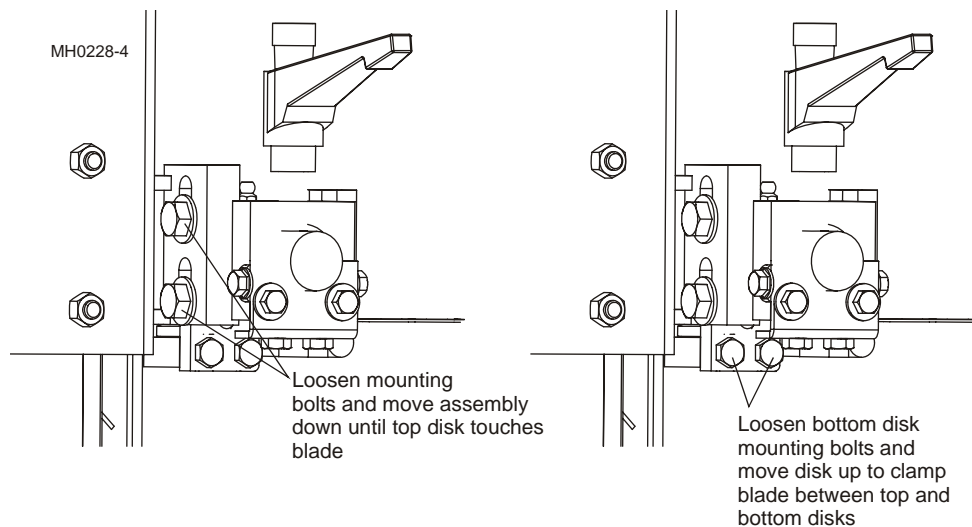

**FIG. 4-9**

5. Loosen the bottom disk block mounting bolts and raise the lower disk until the blade is clamped between the top and bottom disks. Retighten the lower disk mounting bolts.
6. Loosen the outer blade guide mounting bolts and move the assembly down until the roller touches the top of the blade. Retighten the mounting bolts.

See Figure 4-10.

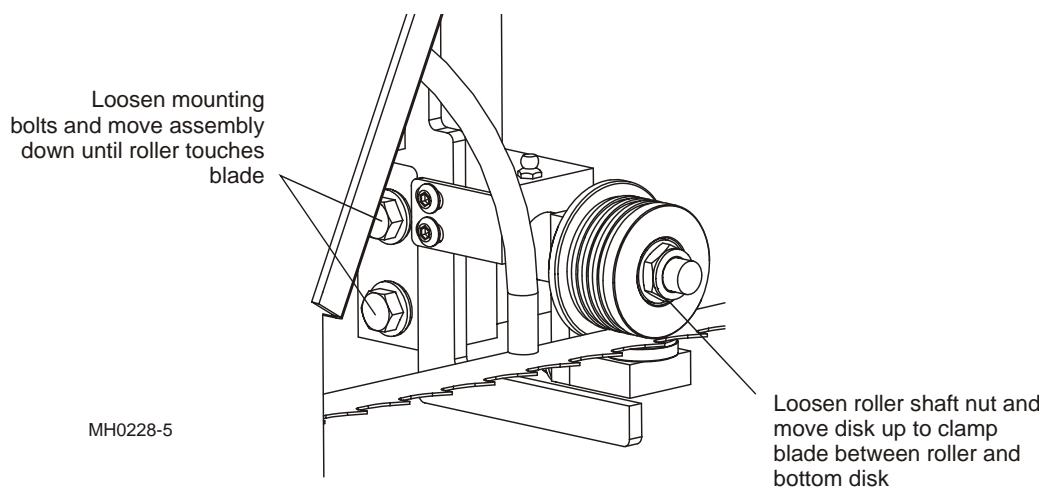
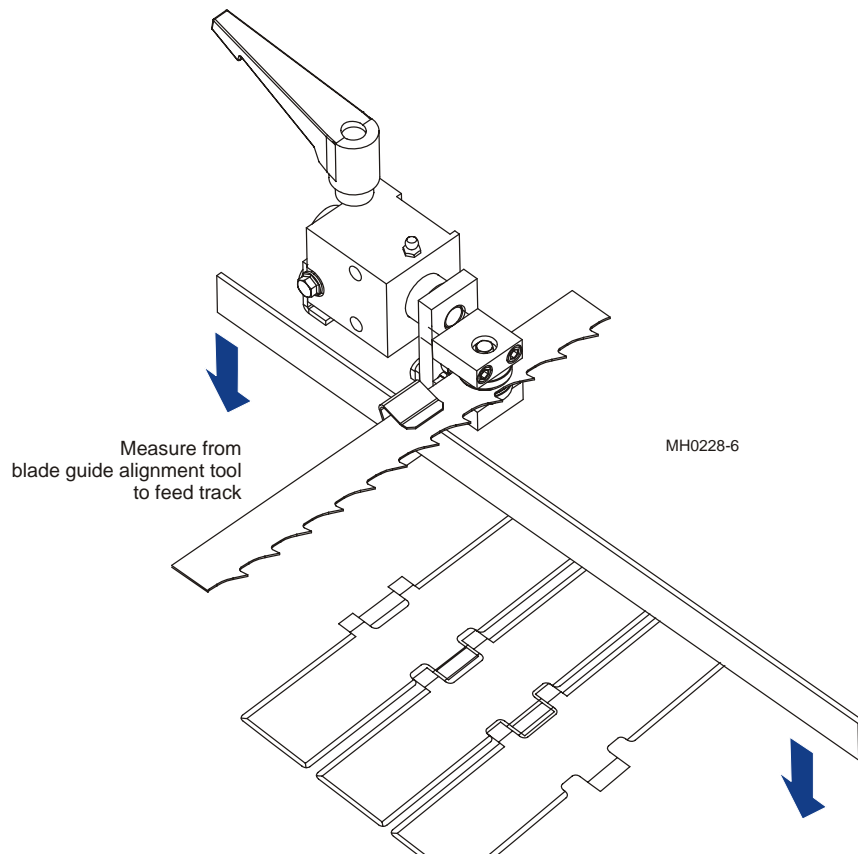

**FIG. 4-10**

7. Loosen the roller shaft nut and raise the lower disk until the blade is clamped between the roller and bottom disk. Retighten the roller shaft nut.

### Blade Guide Vertical Tilt Alignment

See **Figure 4-11**. Use the blade guide alignment tool to check the vertical tilt of the inner blade guide:



**FIG. 4-11**

1. Clip the blade guide alignment tool to the blade near the inner blade guide assembly. Make sure the tool does not rest on a tooth or a burr. The tool should rest flat against the bottom of the blade.
2. Measure the distance from the bottom edge of the tool to the feed track at the front end of the tool.
3. Measure the distance from the bottom edge of the tool to the feed track at the rear of the tool.

If the measurements at the front and rear of the tool are the same ( $\pm 1/32$ " [0.8 mm]), the blade is not tilted and adjustment is not necessary.

If the measurement at the front of the tool is larger than the measurement at the rear of the tool, the blade guide is tilted up.

See Figure 4-12. To tilt the blade guide down:

- Loosen the two retaining plate bolts at the rear of the blade guide assembly.

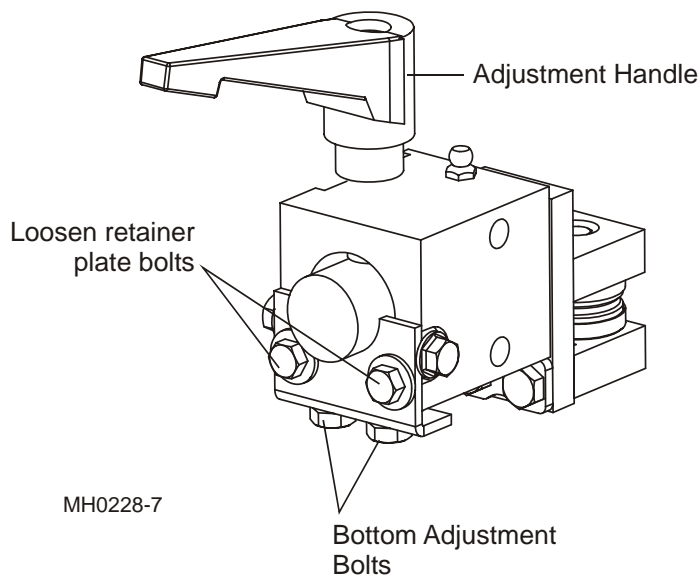

**FIG. 4-12**

- Loosen the adjustment handle and tighten the two bottom adjustment bolts.
- Retighten the adjustment handle and retainer plate bolts.
- Recheck vertical tilt and repeat adjustments as necessary.

If the measurement at the rear of the tool is larger than the measurement at the front of the tool, the blade guide is tilted down.

**To tilt the blade guide up:**

- Loosen the two retainer plate bolts at the rear of the blade guide assembly.
  - Loosen the bottom adjustment bolts. Tighten the adjustment handle. Adjust until the tool is level with the feed track ( $\pm 1/32$ " [0.8 mm]).
  - Retighten the adjustment bolts and the retainer plate bolts.
  - Recheck vertical tilt and repeat adjustments as necessary.
4. After the inner blade guide assembly is adjusted properly, remove the bottom disk mounting bolts and bottom disk assembly.

5. Move the Blade Guide Alignment Tool near the outer blade guide assembly. Repeat vertical tilt adjustments for the outer blade guide assembly.
6. After the outer blade guide assembly is adjusted properly, loosen the roller shaft nut and lower the bottom disk as far as possible. Retighten the roller shaft nut.

### ***Blade Deflection***

1. Loosen the mounting bolts on both blade guide assemblies and adjust them up so the roller and top disk do not touch the blade.
2. Measure the distance from the blade to a bed rail, near the outer blade guide. Tap the outer blade guide assembly down until the roller pushes the blade down 1/8" as measured from the blade to the bed rail. Retighten the outer blade guide mounting bolts.
3. Loosen the roller shaft nut and adjust the lower disk up until it is .008" from the bottom of the blade. A shim is provided to easily determine this measurement. Retighten the roller shaft nut.
4. Adjust the inner blade guide assembly down until the top disk is as close the blade as possible without touching the blade. Tighten the mounting bolts.
5. Reinstall the bottom disk and adjust up until it is .008" from the bottom of the blade (using the shim). Tighten the bottom disk mounting bolts.
6. Reinstall the deflector guard to the inner blade guide assembly. Position close to, but not touching the bottom of the blade and tighten the guard mounting bolts.

# 4

## Alignment

### Blade Guide Side-To-Side Tilt Alignment

#### Blade Guide Side-To-Side Tilt Alignment

1. Remove the blade guide alignment tool from the blade and remove the clip from the tool. Place the tool against the face of the outer blade guide roller.

See Figure 4-13.

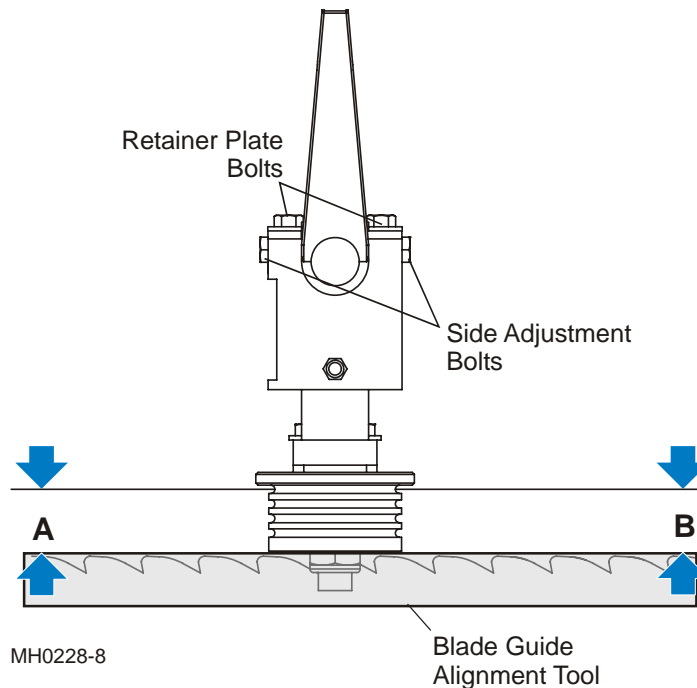

FIG. 4-13

2. Measure between the back edge of the blade and the tool at the end closest to the inner blade guide ("B").
3. Measure between the back edge of the blade and the other end of the tool ("A").

The roller should be parallel to the blade ('A' = 'B').

- Loosen the two retainer plate bolts at the rear of the blade guide assembly.
  - Loosen one side adjustment bolt and tighten the other to tilt the blade guide in the direction necessary.
  - Repeat steps 1-4 until the alignment tool is parallel to the blade.
  - Retighten the two retainer plate bolts.
4. Repeat the above steps for the inner blade guide roller assembly. Place the alignment tool against the top disk block.



**Saw Head Tilt**

1. After the blade guides are adjusted as described above, raise or lower the saw head so the blade is at an easy-to-measure distance from the track (e.g., 6" or 150 mm).

**See Figure 4-14.** Measure from the bottom of the blade to the track at the inside and the outside of the throat. If the two measurements are exactly equal or up to 1/32" (0.75 mm) higher on the outside, the blade is parallel to the feed track and no adjustment is necessary.

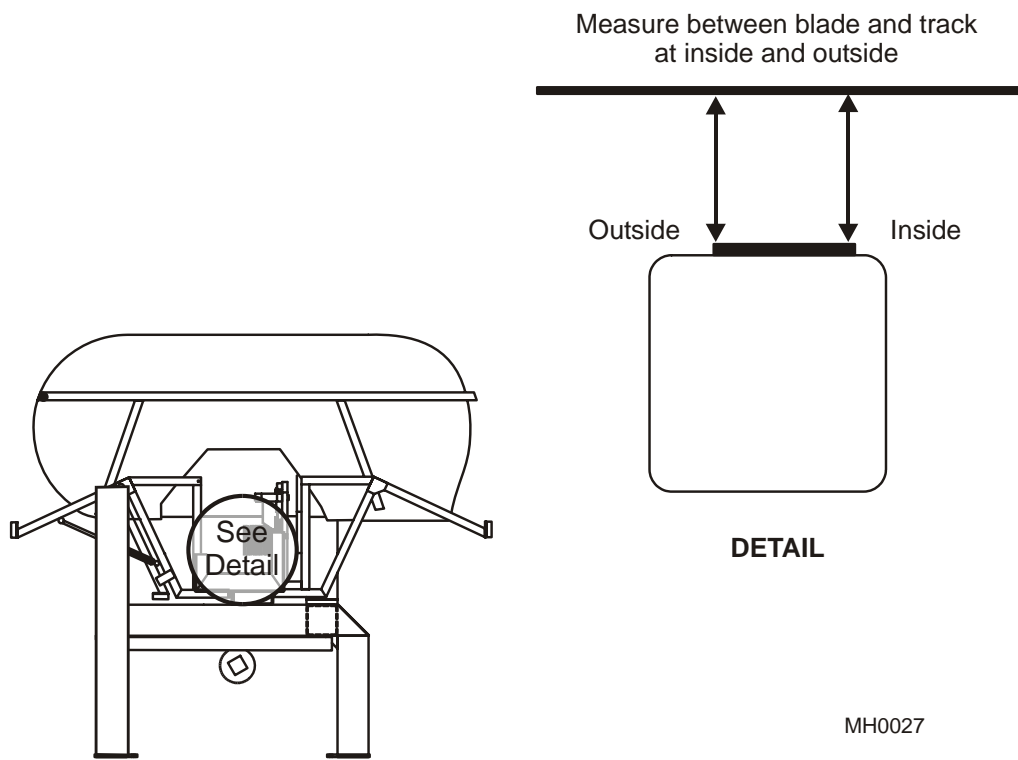

MH0027

**FIG. 4-14**

## 4 Alignment

### Saw Head Tilt

2. If the outside dimension is less than the inside dimension, the outside of the saw head needs to be raised.

See **Figure 4-15**. Locate the mounting bolts and adjusting bolts at the base of the saw head mounting tube.

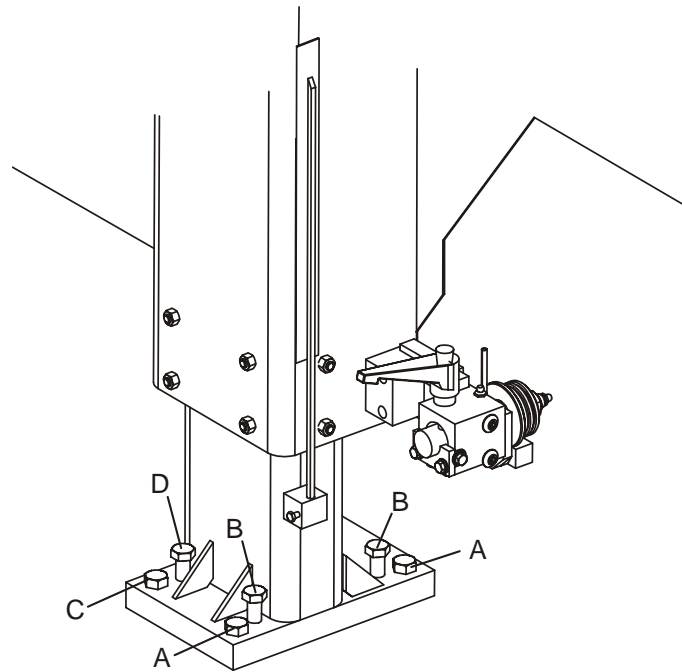

MH0202B

**FIG. 4-15**

#### To raise the outside of the saw head:

First check the current adjustment of the saw head tilt bolts. If the saw head mount plate is flat against the frame tube, use the inside set of bolts (A & B) to raise the outside of the saw head. If the outside adjustment bolts (C & D) are adjusted so they raise the mounting plate off the frame tube, use the outer set of bolts to raise the outside of the saw head.

Using the inside bolts (A & B) to raise the saw head:

1. Loosen the two inside mounting bolts 'A'.
2. Turn the adjusting bolts 'B' clockwise. Recheck the dimensions from the blade to the track.
3. Repeat adjustments until the blade measures 1/16" (1.5 mm) higher at the outside of the saw head. Then tighten mounting bolts 'A' until the outside measurement is exactly the same as or up to 1/32" (0.75 mm) higher than the inside measurement.

Using the outside bolts (C & D) to raise the saw head:

1. Turn the adjusting bolts 'D' counterclockwise.
2. Tighten the mounting bolts 'C' until the saw head mounting plate is flat against the frame tube.
3. Recheck the dimensions from the blade to the track.
4. If the outside of the saw head is still lower than the inside, use the inside set of adjustment bolts 'A' and 'B' to continue raising the outside of the saw head (See previous page).
5. If the outside of the saw head is higher than the inside, readjust the outside set of adjustment bolts to lower the outside of the saw head. Loosen the mounting bolts 'C' and turn the adjusting bolts 'D' clockwise.
6. Recheck the dimensions from the blade to the track.
7. Repeat adjustments until the blade measures 1/16" (1.5 mm) higher at the inside of the saw head. Then tighten mounting bolts 'C' until the inside measurement is exactly the same as or up to 1/32" (0.75 mm) lower than the outside measurement.
8. If the outside dimension is more than 1/32" (0.75 mm) higher than the inside dimension, the outside of the saw head needs to be lowered.

**To lower the outside of the saw head:**

First check the current adjustment of the saw head tilt bolts. If the saw head mount plate is flat against the frame tube, use the outside set of bolts (C & D) to lower the outside of the saw head. If the inside adjustment bolts (A & B) are adjusted so they raise the mounting plate off the frame tube, use the inside set of bolts to lower the outside of the saw head.

Using the outside bolts (C & D) to lower the saw head:

1. Loosen the two outside mounting bolts 'C'.
2. Turn the adjusting bolts 'D' counterclockwise. Recheck the dimensions from the blade to the track.
3. Repeat adjustments until the blade measures the same distance from the track at the outside and inside of the saw head. Then tighten mounting bolts 'C', making sure the outside measurement remains exactly the same as or up to 1/32" (0.75 mm) higher than the inside measurement.

Using the inside bolts (A & B) to lower the saw head:

# 4

## Alignment *Saw Head Tilt*

---

1. Turn the adjusting bolts 'A' counterclockwise.
2. Tighten the mounting bolts 'B' until the saw head mounting plate is flat against the frame tube.
3. Recheck the dimensions from the blade to the track.
4. If the outside of the saw head is still higher than the inside, use the outside set of adjustment bolts 'C' and 'D' to continue lowering the outside of the saw head (See previous page).
5. If the outside of the saw head is lower than the inside, readjust the inside set of adjustment bolts to raise the outside of the saw head. Loosen the mounting bolts 'A' and turn the adjusting bolts 'B' clockwise.
6. Recheck the dimensions from the blade to the track.
7. Repeat adjustments until the blade measures 1/16" (1.5 mm) higher at the outside of the saw head. Then tighten mounting bolts 'A' until the inside measurement is exactly the same as or up to 1/32" (0.75 mm) lower than the outside measurement.

## SECTION 5 SPECIFICATIONS

### 5.1 Dimensions

See Figure 5-1. The major dimensions of the MultiHead (Rev. A1.00 manufactured 11/99 or later) are provided.

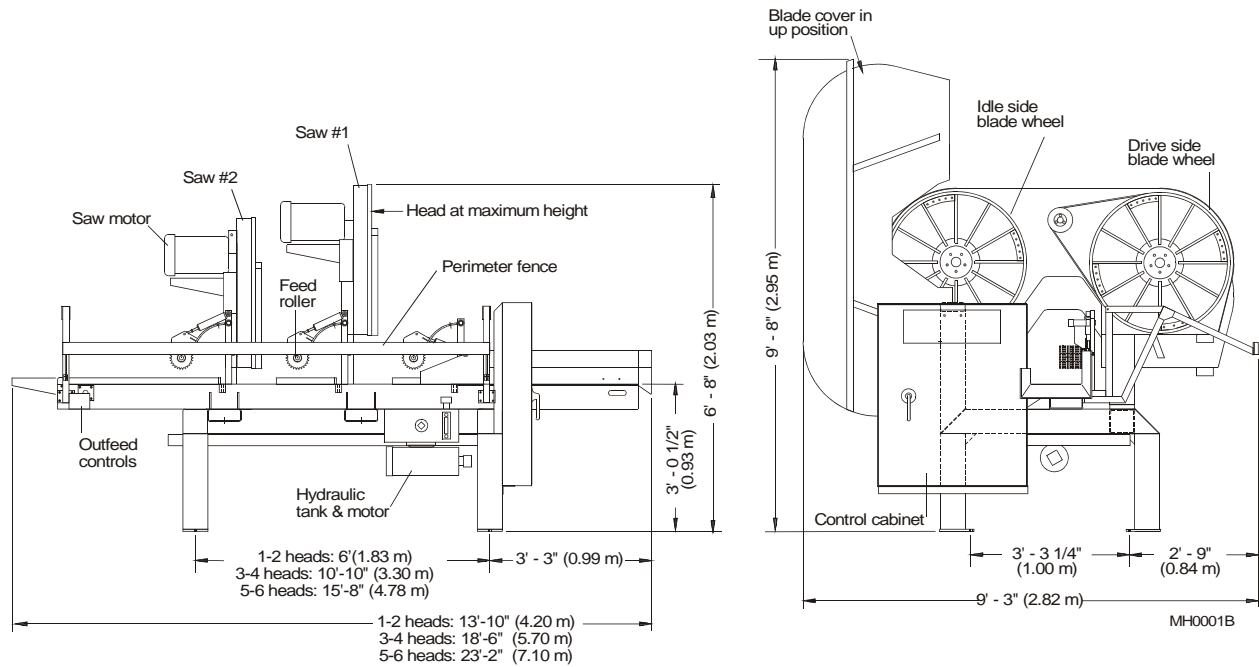

**FIG. 5-1 REV. A1.00 (11/99)+**

See Table 5-1. Machine weight, height, width and length dimensions are listed below.

<b>Weight (MH6D12)</b>	7720 lbs. (3502 kg)
<b>Height</b>	80" (203.20 cm)
<b>Width</b>	94" (238.76 cm)
<b>Length (1-2 head)</b>	13' - 10" (4.20 m)
<b>Length (3-4 head)</b>	18' - 6" (5.70 m)
<b>Length (5-6 head)</b>	23' - 2" (7.10 m)

**TABLE 5-1**

## 5.2 Cutting Capacity

See **Table 5-2**. The cutting size capacities and blade sizes you can use on the Multi-Head are listed below.

<b>Cutting Length</b>	18" (0.45 m) minimum 96" (2.45 m) maximum <sup>1</sup>
<b>Cutting Height</b>	.25" - 12" (0.64 cm - 30.48 cm) <sup>2</sup>
<b>Cutting Width</b>	.75" - 12" (1.91 cm - 30.48 cm) <sup>3</sup>
<b>Blade Kerf</b>	.070" - .084" (1.52 mm - 2.03 mm)
<b>Blade Width</b>	1" (2.54 cm) or 1.25" (3.18 cm)
<b>Blade Length</b>	17' - 1" (5.2 m)
<b>Blade Thickness</b>	.035" (0.89 mm), .042" (1.07 mm) or .045" (1.14 mm)

**TABLE 5-2**

<sup>1</sup> 72" (1.83 m) maximum if equipped with 6' MGR.

<sup>2</sup> 8" (20 cm) if equipped with optional hold-downs.

<sup>3</sup> 8" (20.32 cm) maximum if equipped with MGR. Prior to revision A1.00 (11/99), 8" width was standard and 12" width was optional. 12" width is now standard and 8" width is no longer available.

### 5.3 Motor Specifications

See **Table 5-3**. The specifications of the electric motors on the MultiHead are listed below.

Motor	kW	Type	RPM@50HZ
Saw Head(s)	15	Totally Enclosed, Fan Cooled	2896
	11	Totally Enclosed, Fan Cooled	2850
Hydraulic Pump	3	Totally Enclosed, Fan Cooled	2850

**TABLE 5-3**

See **Table 5-4**. The noise levels of the Wood-Mizer resaw are listed below<sup>\*\*\*</sup>

	Engaged
<b>MULTIHEAD</b>	$L_{EX8} = 86,9 \text{ dB (A)}$ (cant loading) $L_{EX8} = 87,7 \text{ dB (A)}$ (cant receiving)

**TABLE 5-4**

\*. The noise level measurement was taken in accordance with PN-EN ISO 3746 Standard . The noise exposure level given above concerns an 8-hour work day.

\*\* . The measured values refer to emission levels, not necessarily to noise levels in the workplace. Although there is a relation between emission levels and exposure levels, it is not possible to determine with certainty if preventives are needed or are not needed. The factors affecting a current level of noise exposure during work are inter alia room characteristics and characteristics of other noise sources, e.g. number of machines and machining operations nearby. Also, the permissible exposure level value may vary depending on country. This information enables the machine's user to better identify hazards and a risk.

### 5.4 Electrical diagrams

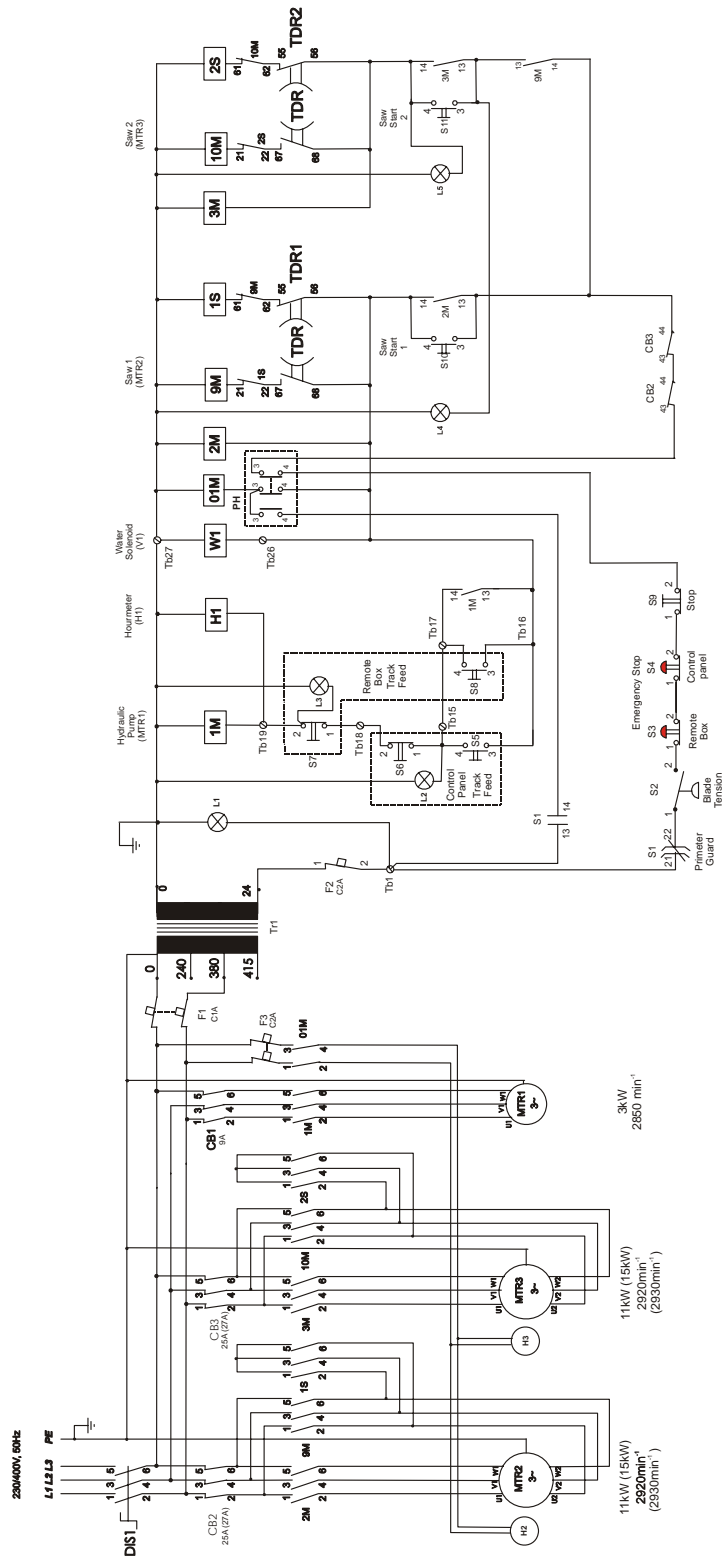

**FIG. 5-2 SCHEMATIC MULTIHEAD 2-HEAD, 11KW, 15KW**



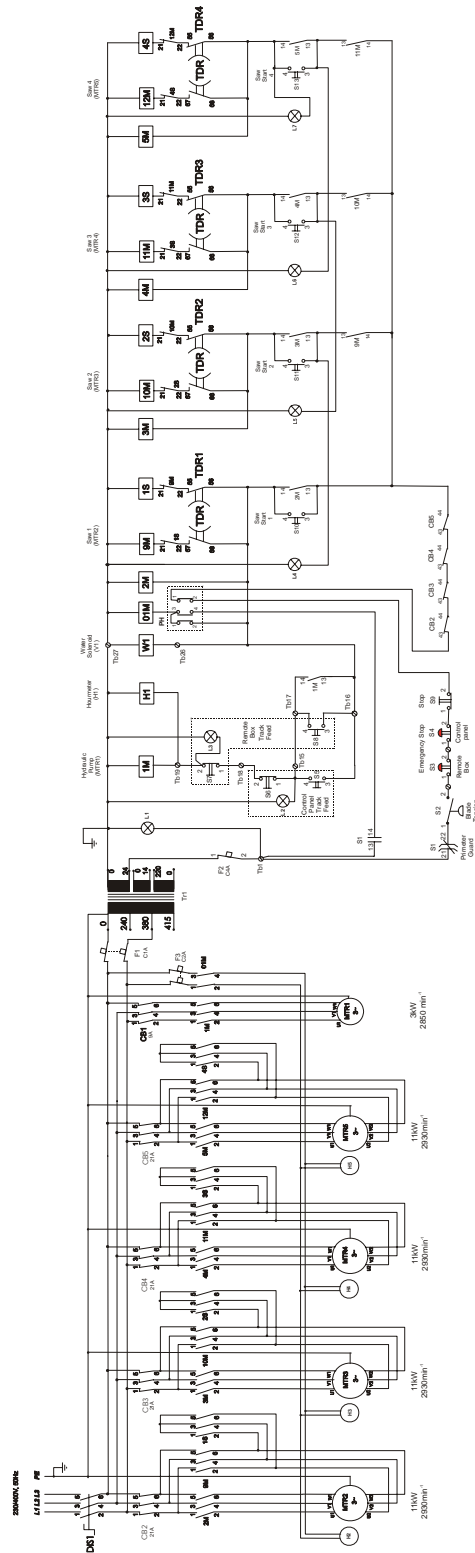
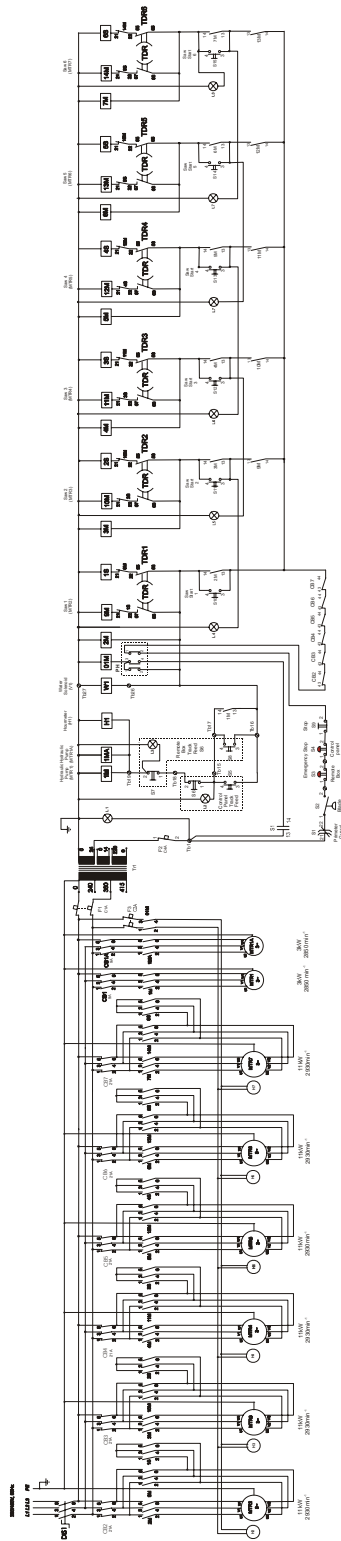

FIG. 5-3 SCHEMATIC MULTIHEAD 4-HEAD, 11KW

# 5 Specifications

## Electrical diagrams



**FIG. 5-4 SCHEMATIC MULTIHEAD 6-HEAD, 11KW**

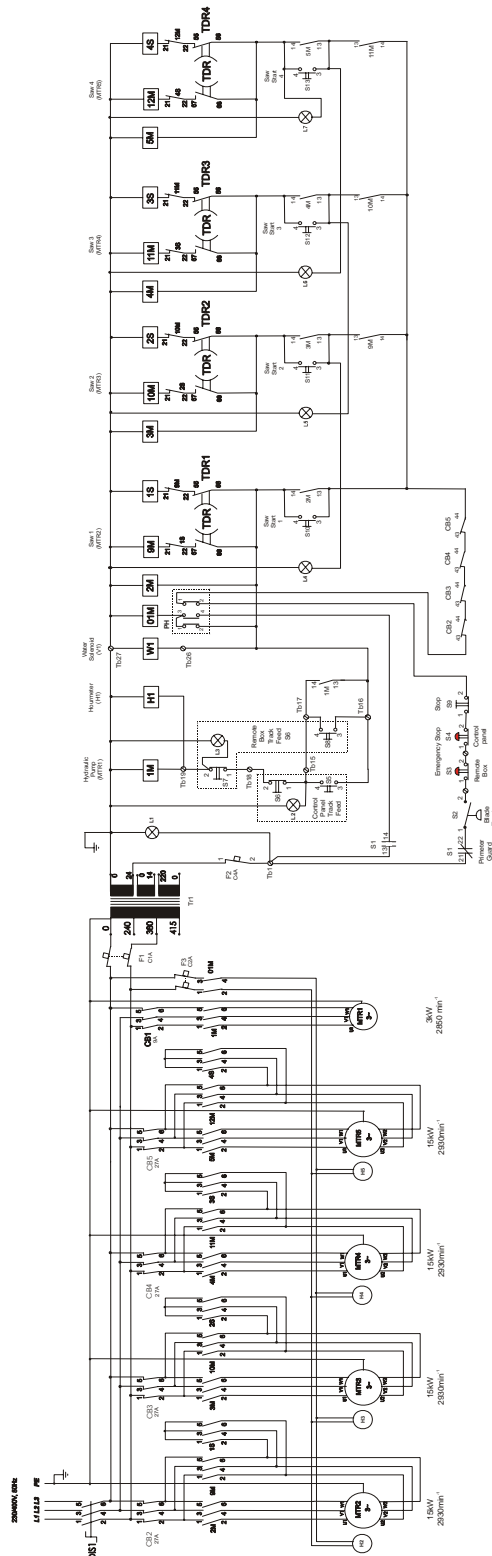
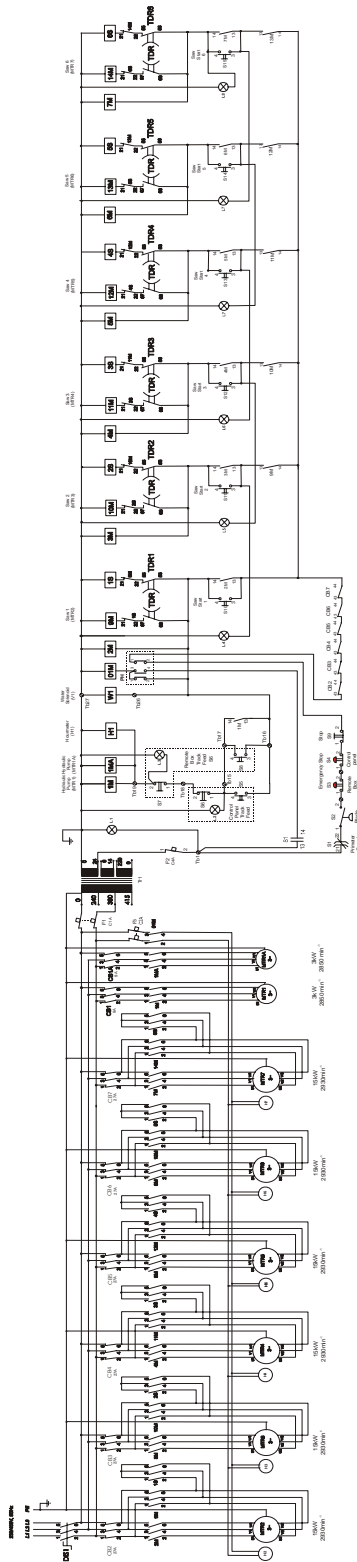

FIG. 5-5 SCHEMATIC MULTIHEAD 4-HEAD, 15KW

# 5 Specifications

## Electrical diagrams



**FIG. 5-6 SCHEMATIC MULTIHEAD 6-HEAD, 15KW**

## 5.5 Belt Sizes

See **Table 5-5**. The drive and idle blade wheel belt sizes are listed below.

<b>Belt Description</b>	<b>Belt Size</b>	<b>Wood-Mizer Part No.</b>
Drive Wheel Belt (15HP)	BX120	P22305
Drive Wheel Belt (25HP)	5VX1210	033389 <sup>1</sup>
Idle Wheel Belt (15HP)	BX105	P22306
Idle Wheel Belt (25HP)	5VX1080	033391

**TABLE 5-5**

<sup>1</sup> Belt changed from 5VX1230 to 5VX1210 (12/99) and replaced on all existing MultiHeads with old belt. Pulley 033248 also changed from 25V590SDS to 1/5V5.9SDS.

## 5.6 Fluid Requirements

See **Table 5-6**. Hydraulic and water lube (optional bottle design) capacities and requirements.

<b>Hydraulic Reservoir Capacity</b>	4 to 5 gal.
<b>Hydraulic Fluid</b>	Exxon Univas HVI 26 <sup>1</sup>
<b>Hydraulic Filter</b>	S28
<b>Water Bottle Capacity</b>	4 gal. (per saw)

**TABLE 5-6**

<sup>1</sup> Replaces Amoco Rycon Oil MV or Mobil Multipurpose ATF used prior to 11/99. Gallon cans of Univas HVI 26 available from Wood-Mizer (Part No. P12823). Formerly named J26.

## 5.7 Air Service Requirements

See Table 5-7. The air service requirements for the MultiHead are listed below.

<b>Air Pressure</b>	Min. 80 psi (5,5 bar) Max 125 psi (8,6 bar)
<b>Air Volume</b>	142 litres/min.
<b>Fitting Required</b>	1/8" NPT (1/4" NPT w/MGR)

**TABLE 5-7**

## 5.8 Dust Extractor Specifications

See Table 5-8. Specifications of the dust extractors used on the Multihead for each saw head are listed below.

<b>Airflow</b>	1200 m <sup>3</sup> /h
<b>Inlet diameter</b>	150 mm
<b>Motor power</b>	1,5 kW
<b>Number of sacks</b>	1 pcs
<b>Sack capacity</b>	0.25 mp
<b>Weight</b>	110 kg
<b>Recommended conveying air velocity in the duct</b>	20 m/s

**TABLE 5-8**



**IMPORTANT!** The dust extractor hoses must be grounded or made with materials not accumulating electrostatic charge.

## 5.9 Hydraulic System

See Figure 5-7. Hydraulic Schematic

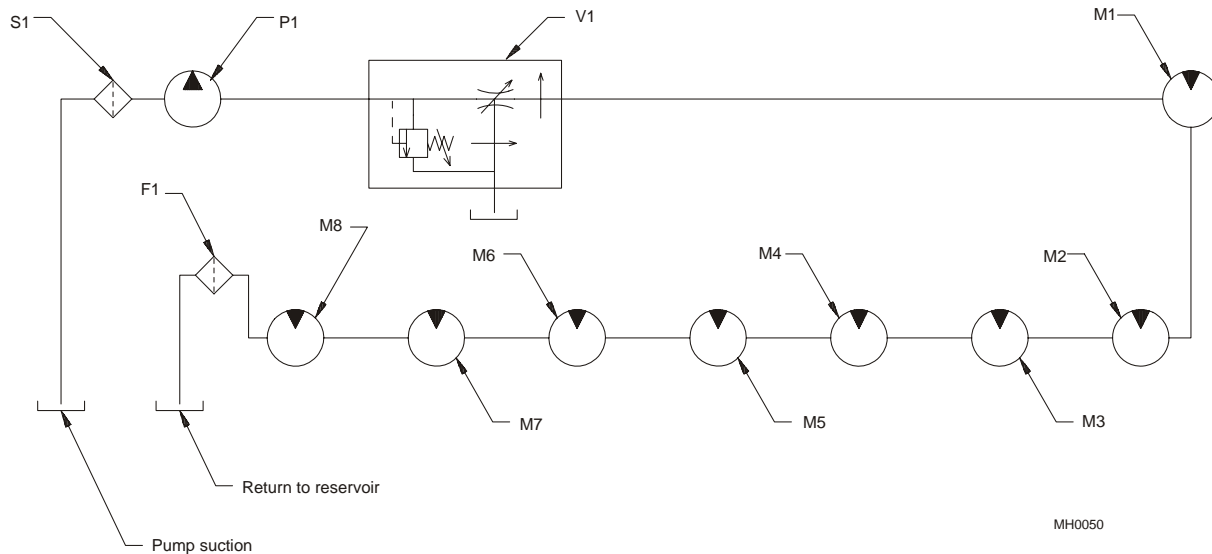

**FIG. 5-7**

See Table 5-9. Hydraulic Component List

Component	Manufacturer Part Number	Manufacturer	Wood-Mizer Part Number	Description
F1	SAF28G12	MFP	P20301	Filter, Hydraulic Fluid Cartridge
M1 - M8	MG10-13-10AAAB	TRW Ross	P20206	Motor, Hydraulic
P1	1300096	J.S. Barnes	P20213	Pump, Hydraulic
S1	S15-100	Flo-Ezy	P20210	Filter, Suction Screen
V1	FCR51-3/8	Brand	P20743	Valve, Flow Control

**TABLE 5-9**



**See Table 5-10.** Hydraulic Hose Chart

Hydraulic Hose Description	Wood-Mizer Part Number
1/2" NPT x 34" Long Hydraulic Hose	P20249
1/2" NPT x 66" Long Hydraulic Hose	P20716
1/2" NPT x 76" Long Hydraulic Hose	P22626
1/2" NPT x 28" Long Hydraulic Hose	P05391
1/2" NPT x 78" Long Hydraulic Hose	P22299
1/2" NPT x 11' Long Hydraulic Hose (MGR Only)	P21545
1/2" NPT x 13' Long Hydraulic Hose (MGR Only)	P21126

**TABLE 5-10**

## 5.10 Connection Specifications

**See Table 5-11.** Depending on the number of saw heads, you should use different circuit breakers and power cord cross sections. See the table below for the required connection specifications.

Number of saw heads	Circuit Breaker [A]	Power Cord Cross Section [mm <sup>2</sup> ]
2	50	10
4	100	25
6	160	50

**TABLE 5-11**

## EC declaration of conformity according to EC Machinery Directive 2006/42/EC

We herewith declare,

Wood-Mizer Industries sp. Z O.O.  
114 Nagorna street, 62-600 Kolo; Poland.

That the following described machine in our delivered version complies with the appropriate basic safety and health requirements of the EC Machinery Directive 2006/42/EC based on its design and type, as brought into circulation by us. In case of alteration of the machine, not agreed by us, this declaration is no longer valid.

Designation of the machine:	<b>Multihead Resaw</b>
TYPE:	MH
Models:	MH1-6D12S
No. of manufacturer:	.....
Applicable EC Directives:	EC Machinery Directive 2006/42/EC EC Low-Voltage Directive 73/23/EEC EC Electromagnetic Compatibility Directive 2004/108/EC
Applicable Harmonized Standards:	EN ISO 12100-1; EN 12100-2; EN 1807; EN 60204-1;
Notified Body according to annex IV :	TUV Product Service GmbH Gottlieb-Daimler Strasse 7 70794 Filderstadt
Responsible for:	EC type examination
Responsible for Technical Documentation:	Roman Frontczak / R&D Director
Date/Authorized Signature:	29. 12. 2009 
Title:	R&D Director

# INDEX

---

## A

alignment  
  block/roller blade guides 4-4  
  ceramic blade guides 4-13  
  preliminary 4-1

---

## B

belt  
  replacement 3-11  
  tension 3-12

blade  
  height indicator adjustment 3-8, 3-10, 3-11, 3-13,  
    3-14, 3-15, 3-16, 3-17, 3-18, 3-19, 3-20,  
    3-21, 3-22, 3-24, 3-25, 3-26, 3-27

blade guide  
  maintenance 3-1  
  replacement 3-15

blade wheel  
  belt replacement 3-11

---

## C

control overview 2-1

---

## F

feed roller  
  lubrication 3-14

feed rollers  
  maintenance 3-15

---

## H

hydraulic  
  component list 5-12  
  hose chart 5-13  
  schematic 5-12  
  system maintenance 3-18  
  system overview 2-6

---

## M

maintenance  
  periodic schedule 3-26  
  routine schedule 3-25

---

## O

operation  
  procedure 2-28  
  shutdown 2-26  
  start 2-22

---

## P

perimeter fence 2-8  
  lubrication 3-19

---

## S

safety  
  instructions 1-2  
  symbols 1-1

saw head mount  
  tube lubrication 3-20

sawdust  
  removal 3-11, 3-17

setup

- blade guide arm adjustment [2-21](#)
- blade installation [2-11](#)
- fence adjustment [2-20](#)
- recommended blade tension [2-13](#)
- saw height adjustment [2-17](#)

specifications

- belts [5-9](#), [5-14](#)
- cutting capacity [5-2](#)
- dimensions [5-1](#)
- fluid requirements [5-10](#)
- motors [5-3](#)

switch

- blade shutoff adjustment [3-9](#)

---

**T**

tension

- drive belt [3-12](#)

tensioner

- lubrication [3-21](#)
- screw adjustment [3-22](#)

troubleshooting

- electrical problems [3-27](#)

---

**U**

up/down

- lubrication [3-24](#)
- pad adjustment [3-7](#)