

Industrial Wash Station

(Safety, Operation, Maintenance
& Parts Manual)

BWS100

Rev. A1.00



Safety is our #1 concern! Read and understand all safety information and instructions before operating, setting up or maintaining this machine.

Form #723

Table of Contents

Section-Page

SECTION 1	SAFETY & GENERAL INFORMATION	1-1
1.1	Electrical Safety.....	1-2
1.2	Blade Handling.....	1-2
1.3	Machine Operation	1-3
1.4	Wash Station Components	1-4
1.5	Overall Dimensions and Other Technical Data.....	1-5
1.6	Technical Data.....	1-6
1.7	Control Panel Components.....	1-8
SECTION 2	SETUP & OPERATION	2-1
2.1	Machine Operation	2-1
SECTION 3	MAINTENANCE	3-1
3.1	Bearings.....	3-1
3.2	Brushes	3-1
3.3	Carbide Insert Replacement	3-1
SECTION 4	TROUBLESHOOTING	4-1
SECTION 5	WASH STATION PARTS	5-1
5.1	How To Use The Parts List	5-1
5.2	Stand Assembly	5-2
5.3	Adjustable Foot	5-3
5.4	Filter tank	5-4
5.5	Blade Drive Assembly	5-6
5.6	Blade Support Arms	5-9
5.7	Pre-Cleaning Assembly	5-10
5.8	Upper tank	5-13
5.9	Drive Lid Bracket	5-15
5.10	Drive Lid Assembly	5-16
5.11	Brush Arm	5-19
5.12	Tensioning Roller Arm	5-21
5.13	Belt Tension Wheel Assembly	5-23
5.14	Wash Station Decals	5-24
SECTION 6	ELECTRICAL INFORMATION	6-1
6.1	Electrical Symbol Diagram	6-1
6.2	Electrical Components.....	6-2

SECTION 1 SAFETY & GENERAL INFORMATION



This symbol calls your attention to instructions concerning your personal safety. Be sure to observe and follow these instructions. This symbol accompanies a signal word. The word **DANGER** indicates an imminently hazardous situation which, if not avoided, will result in death or serious injury. **WARNING** suggests a potentially hazardous situation which, if not avoided, could result in death or serious injury. **CAUTION** refers to potentially hazardous situations which, if not avoided, may result in minor or moderate injury to persons or equipment. Read all safety instructions before operating this equipment and observe all safety warnings!



Warning stripes are placed on areas where a single decal would be insufficient. To avoid serious injury, keep out of the path of any equipment marked with warning stripes.

Read and observe all safety instructions before operating this equipment! Also read any additional manufacturer's manuals and observe any applicable safety instructions including dangers, warnings, and cautions.

Always be sure that all safety decals are clean and readable. Replace all damaged safety decals to prevent personal injury or damage to the equipment. Contact your local distributor, or call your Customer Service Representative to order more decals.

Always properly dispose of all by-products, including debris, coolant and oil.

Safety instructions are listed in this section by the following operations:

- Electrical Safety
- Blade Handling
- Machine Operation

1.1 Electrical Safety



DANGER! Make sure all electrical installation, service and/or maintenance work is performed by a qualified electrician and is in accordance with applicable electrical codes.

DANGER! HAZARDOUS VOLTAGE can cause shock, burns, or death. SHUT OFF & LOCK OUT POWER before performing service in any area of this machine. DO NOT restore power until all access panels are replaced and secured.

DANGER! For the user's safety, the power cord should only be used with properly grounded receptacles to avoid electrical shock. To prevent electrical shock hazard, this unit must be powered with a connector equipped with a secure circuit (current change switch).

1.2 Blade Handling



WARNING! Always wear gloves and eye protection when handling bandsaw blades. Keep all persons away from area when coiling or carrying a blade.

1.3 Machine Operation



DANGER! Make sure all guards and covers are in place and secured before operating the wash station. Failure to do so may result in serious injury.

DANGER! Lid must be closed for machine operation. Keep all persons out of the path of lid and away from moving parts when operating this machine. Failure to do so will result in serious injury.

DANGER! Always keep hands away from moving bandsaw blade. Failure to do so will result in serious injury.



WARNING! Always wear eye protection when operating this machine. Failure to do so may result in serious injury.

WARNING! Secure all loose clothing and jewelry before operating this machine. Failure to do so may result in serious injury or death.

WARNING! Contains hot liquid! Keep hands away from tank! Failure to do so may result in serious injury.

1.4 Wash Station Components

See Figure 1-1. The major components of the Wash Station are shown below.

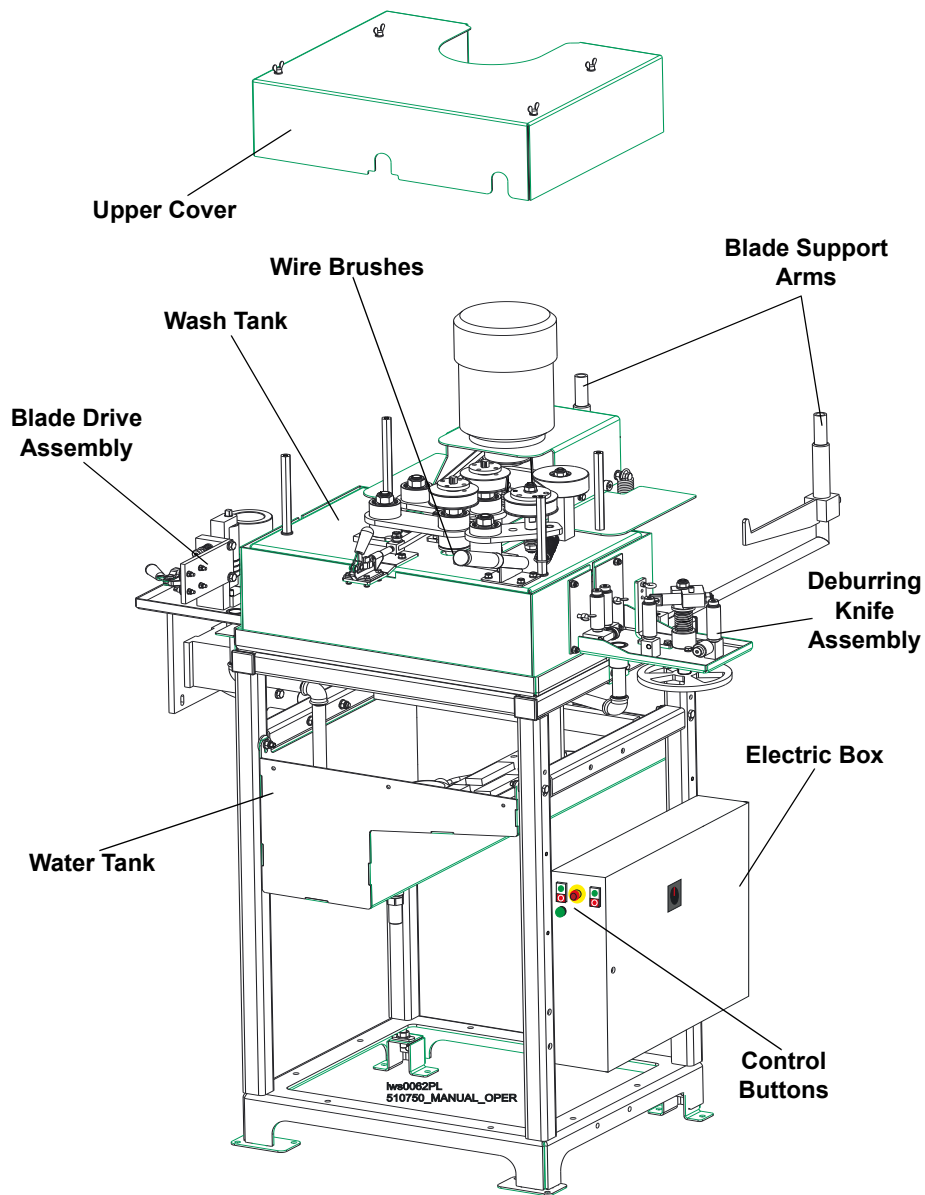

FIG. 1-1

1.5 Overall Dimensions and Other Technical Data

See **Table 1-1**. The overall dimensions and the weight of the Wash Station (without the blade support arms, and closed lid) are listed below.

Model	Length	Width	Height	Weight
Wash Station	1046mm	1140mm	1497mm	240kg

TABLE 1-1

See **Figure 1-2**. The figure below shows the overall dimensions of the Wash Station with the blade support arms installed.

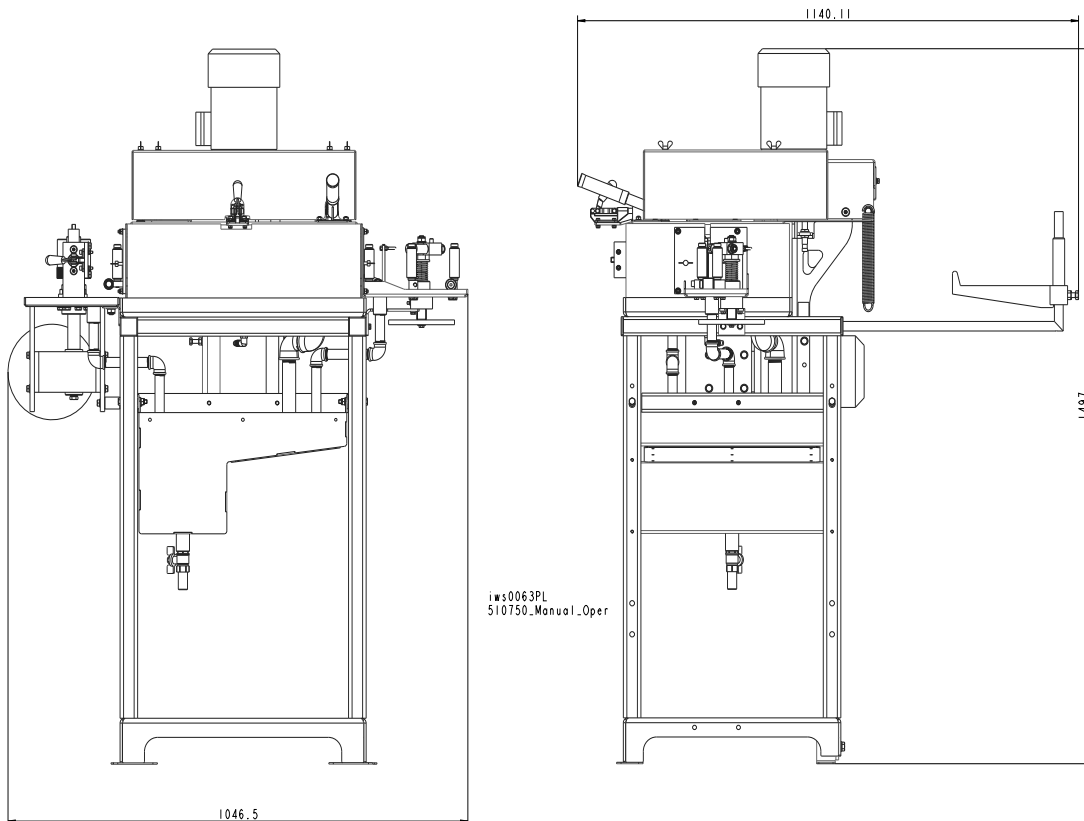

FIG. 1-2

See Table 1-2. The noise level produced by the washer is given below.¹

Noise Level
68,5 dB (A)

TABLE 1-2

See Table 1-3. The motors specifications are listed below.

Motor	Manufacturer	Model	Power	Other data
Electric, Brushes Drive	Besel	SEMKn 80 4B2	0,75kW	4,9A, 1370 r.p.m.
Electric, Blade Drive	Besel	SEMKn 80 4B	0,55kW	3,9 A, 1360 r.p.m.
Electric, Skimmer Drive Motor	Klauber Machine & Gear	K01134A800	24W	230V, 50Hz, 5 r.p.m.
Electric, Water Pump	Little Giant Pump Company	TE-5-MD-HC	0,125HP (93W)	230V, 50Hz, 1,4A

TABLE 1-3

1.6 Technical Data

See Table 1-4. See the table below for technical data on the washer.

Maximum Blade Width	50 mm
Maximum Blade Thickness	1,4 mm
Feed Rate	0,2m/ min
Tank Capacity	90 l
Total Power	6,5 kW
Brushes RPM	1400 r.p.m.

TABLE 1-4

1. The measured values refer to emission levels, not necessarily to noise levels in the workplace. Although there is a relation between emission levels and exposure levels, it is not possible to determine with certainty if preventives are needed or are not needed. The factors affecting a current level of noise exposure during work are inter alia room characteristics and characteristics of other noise sources, e.g. number of machines and machining operations nearby. Also, the permissible exposure level value may vary depending on country. This information enables the machine's user to better identify hazards and a risk.

See Table 1-5. The power supply must meet the specifications given below.

Voltage	Fuse [A]	Suggested Wire Size	Total Power
230 VAC, 50Hz	32 A	4 mm at least	6,5kW

TABLE 1-5

1.7 Control Panel Components

See Figure 1-3. The controls and their functions are described below.

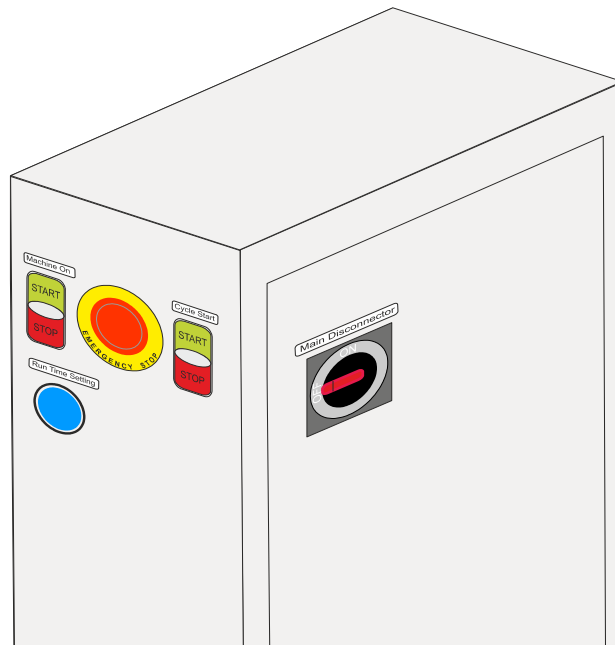

FIG. 1-3

- **Emergency Stop**

The emergency stop switch immediately shuts off all machine operations. NOTE: After activating the emergency stop switch, reset it before starting the wash station again. To reset the switch, turn it counterclockwise and release it.

- **Machine On Button**

This button turns on the machine allowing the machine to operate. Switching on the machine turns on the heater in the water tank.

- **Cycle Start**

This button starts wash cycle.

- **Main Switch**

Turns on/off the machine's main power supply.

SECTION 2 SETUP & OPERATION

2.1 Machine Operation



IMPORTANT! The washing tank must be turned on to heat the water before each use of the washing station.

1. Press the "Machine On" button.
2. To operate the wash station, lift the upper cover.
3. Install the blade in the wash station. Position the blade in front of the rear support guides and between the proper guide posts on the side support arm as shown.

See Figure 2-1.

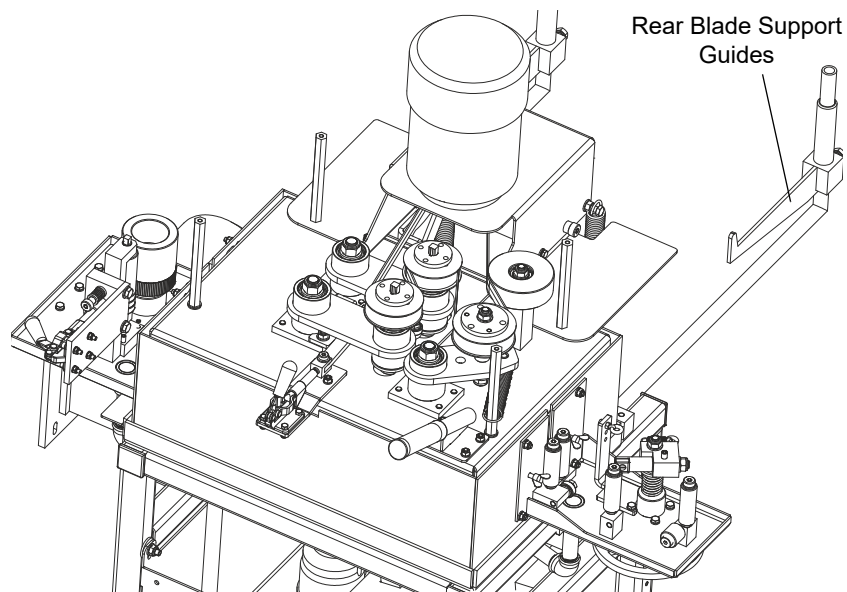

FIG. 2-1

4. Insert the blade sequentially between: the deburring knife, the guide rollers and the blade drive guide.

See Figure 2-2.

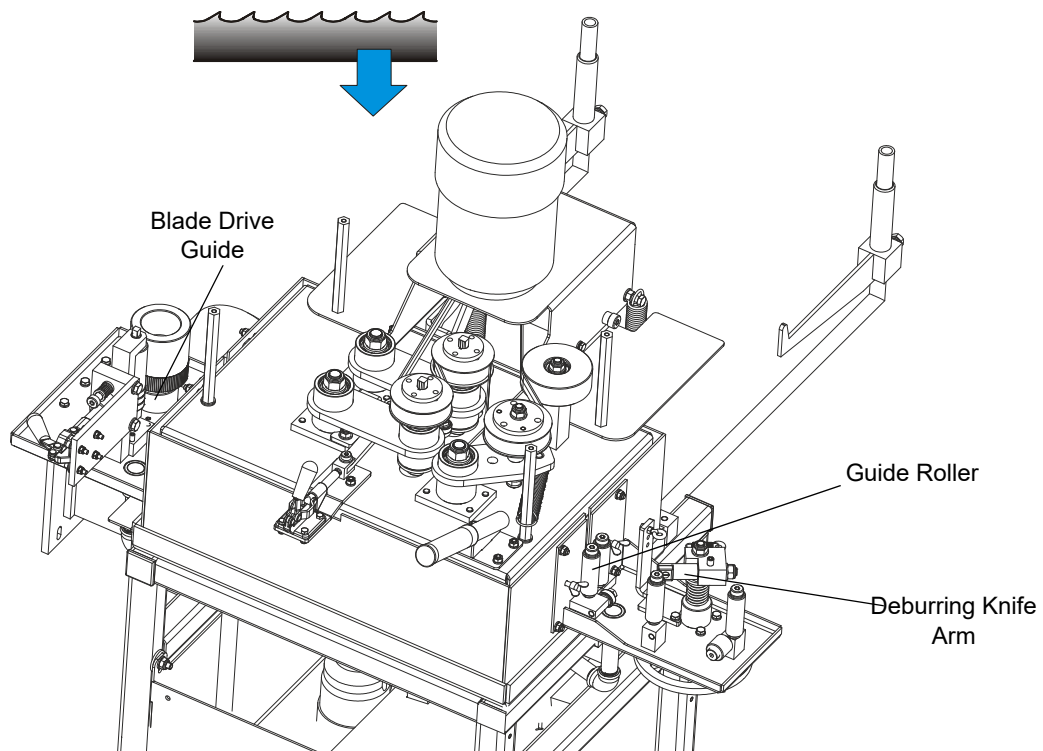

FIG. 2-2

5. Use the handwheel below the deburring knife arm to adjust the height of the deburring knife arms. To effectively deburr the gullet of the blade, the upper edges of the carbide inserts should align with the bend of the tooth, as shown below.

See Figure 2-3.

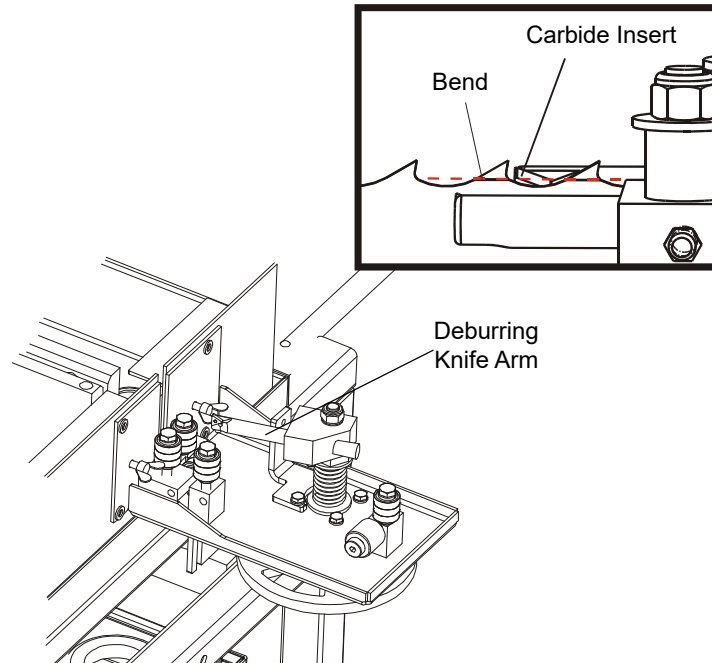

FIG. 2-3

6. Mount the upper cover. Tighten the wire brushes clamp and drive roller clamp as shown below.

See Figure 2-4.

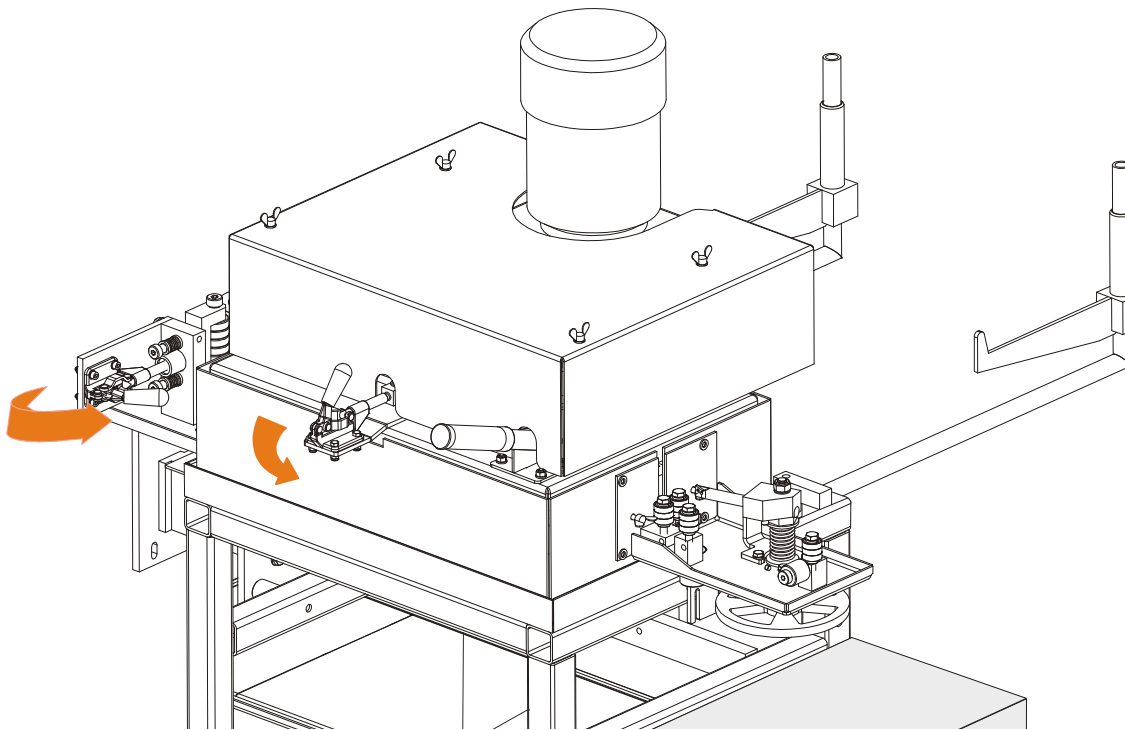

FIG. 2-4

7. Start the wash cycle by pressing the “Cycle Start” button. At the end of the cycle, the wash station will automatically shut off.
8. Run the blade through the wash station until the blade is clean. **NOTE:** If cleaning the blade takes two to three cycles, make sure the water in the tank is clean and at the right temperature. Be sure the wire brushes and deburring knife carbide inserts are in good condition. Service or replace them if necessary and continue operation.



IMPORTANT! If you need to immediately shut down the entire machine at any time, press the Emergency Stop button.

9. Remove the blade. To do this, release the wire brushes clamp and drive roller clamp. Remove the wash station upper cover and slowly remove the blade.

SECTION 3 MAINTENANCE

3.1 Bearings

Replace the brush motor and blade drive motor bearings as necessary.

3.2 Brushes

Periodically check the wire brushes for wear. Replace as necessary.

3.3 Carbide Insert Replacement

Periodically check the deburring knife carbide inserts for sharpness. Replace as necessary.

If an insert edge is worn, rotate the insert to a sharp edge and secure in place. If all edges have been worn, replace the existing insert with a new one.

SECTION 4 TROUBLESHOOTING



DANGER! Make sure all electrical installation, service and/or maintenance work is performed by a qualified electrician and is in accordance with applicable electrical codes.

<i>PROBLEM</i>	<i>CAUSE</i>	<i>SOLUTION</i>
Unit brush motor fails to run	F4 tripped	Reset. If breaker repeatedly trips, check the motor bearings and replace if necessary.
	M3 Motor bad	Replace brush motor
Feed motor fails to run	F3 tripped	Reset. If breaker repeatedly trips, check the motor bearings and replace if necessary.
	M2 Motor bad	Replace feed motor
Lid closes but system will not run	Proximity sensor bad	Replace
Control buttons won't function	Bad fuse (F6)	Reset or replace the fuse

SECTION 5 WASH STATION PARTS

5.1 How To Use The Parts List

- Use the table of contents or index to locate the assembly that contains the part you need.
- Go to the appropriate section and locate the part in the illustration.
- Use the number pointing to the part to locate the correct part number and description in the table.
- Parts shown indented under another part are included with that part.
- Parts marked with a diamond (◆) are only available in the assembly listed above the part.

See the sample table below. Sample Part #A01111 includes part F02222-2 and subassembly A03333. Subassembly A03333 includes part S04444-4 and subassembly K05555. The diamond (◆) indicates that S04444-4 is not available except in subassembly A03333. Subassembly K05555 includes parts M06666 and F07777-77. The diamond (◆) indicates M06666 is not available except in subassembly K05555.

REF				
REF	DESCRIPTION (◆ Indicates Parts Available In Assemblies Only)	PART #	QTY.	
	SAMPLE ASSEMBLY, COMPLETE (INCLUDES ALL INDENTED PARTS BELOW)	A01111	1	
1	Sample Part	F02222-22	1	
	Sample Subassembly (Includes All Indented Parts Below)	A03333	1	
2	Sample Part (◆ Indicates Part Is Only Available With A03333)	S04444-4	1	◆
	Sample Subassembly (Includes All Indented Parts Below)	K05555	1	
3	Sample Part (◆ Indicates Part Is Only Available With K05555)	M06666	2	◆
4	Sample Part	F07777-77	1	

To Order Parts:

- From the continental U.S., call **1-800-525-8100** to order parts. Have your customer number, vehicle identification number, and part numbers ready when you call.
- From other international locations, contact the Wood-Mizer distributor in your area for parts.

5 Wash Station Parts

Stand Assembly

5.2 Stand Assembly

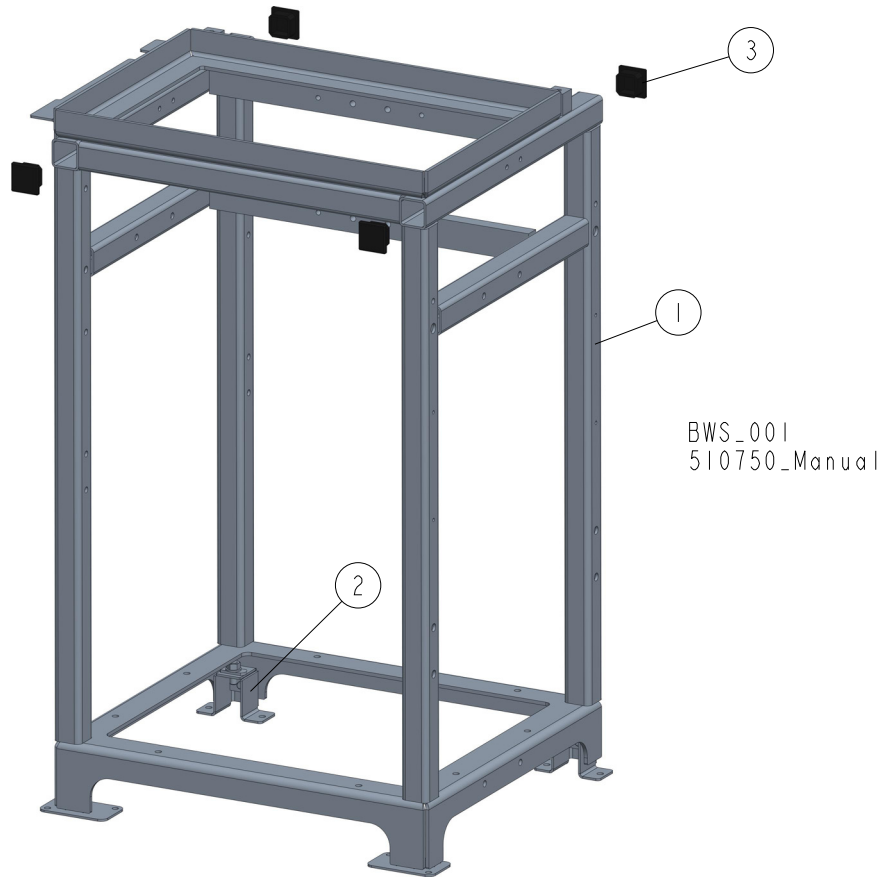

REF	DESCRIPTION (◆ indicates parts available in assemblies only)	PART #	QTY	
1	STAND ASSEMBLY, COMPLETE	510913-1	1	
2	FOOT, ADJUSTABLE COMPLETE See Section 5.4	510700	2	
3	CAP, 40X40X (3-4) TUBE END	097480	4	

5.3 Adjustable Foot

BWS_004
510750_Manual

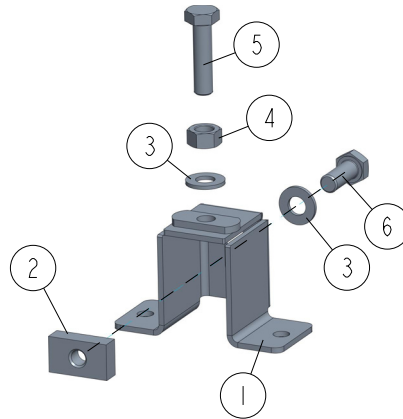

REF	DESCRIPTION (◆ indicates parts available in assemblies only)	PART #	QTY	
	FOOT, ADJUSTABLE COMPLETE	510700	1	
1	FOOT, ADJUSTABLE PTD.	510699-1	1	
2	PLATE, M10 ZINC-PLATED CLAMPING	510698-1	1	
3	WASHER, 10.5 FLAT ZINC	F81055-1	2	
4	NUT, M10-8-B-HEX ZINC	F81033-3	1	
5	BOLT, M10X40-8.8 HEX HEAD FULL THREAD ZI	F81003-16	1	
6	BOLT, M10X25 8.8 HEX HEAD FULL THREAD ZI	F81003-11	1	

5 Wash Station Parts

Filter tank

5.4 Filter tank

BWS_002
510750_Manual

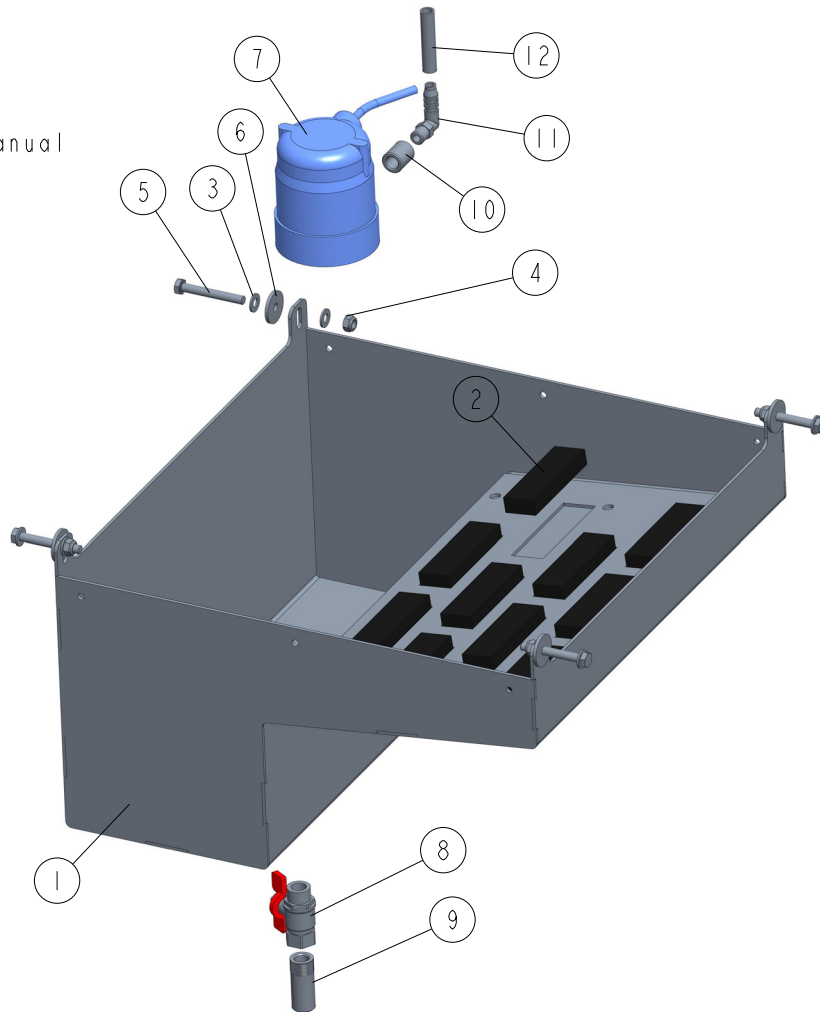

REF.	DESCRIPTION (* Indicates Parts Available In Assemblies Only)	PART #	QTY
	FILTER TANK	504433	1
1	TANK, FILTER	504425-1	1
2	MAGNET, FILTER 100X30X15,	516192	10
3	WASHER, 8.4 FLAT ZINC	F81054-1	8
4	NUT, M8-8-B HEX NYLON ZINC LOCK	F81032-2	4
5	BOLT, M8X60 8.8 HEX HEAD ZINC	F81002-54	4
6	WASHER, SPECIAL 30/8.1X3	511004	4
7	PUMP, AUTO SHARPENER COOLANT	P09836	1
8	VALVE, WATER BALL 1/2" WZ RHM16 MOT.3	516865	1
9	FITTING, THR. 1/2" - 50MM ZINC	516866-1	1
10	BUSHING, G1/4 /20-25	516871	1

REF.	DESCRIPTION (* Indicates Parts Available In Assemblies Only)	PART #	QTY	
11	FITTING WES 10/R 1/4 ELBOW	088379	1	
12	HOSE, MAIN TANK WATER (LENGTH 25,6")	516926	1	

5.5 Blade Drive Assembly

BWS_003
510750_Manual

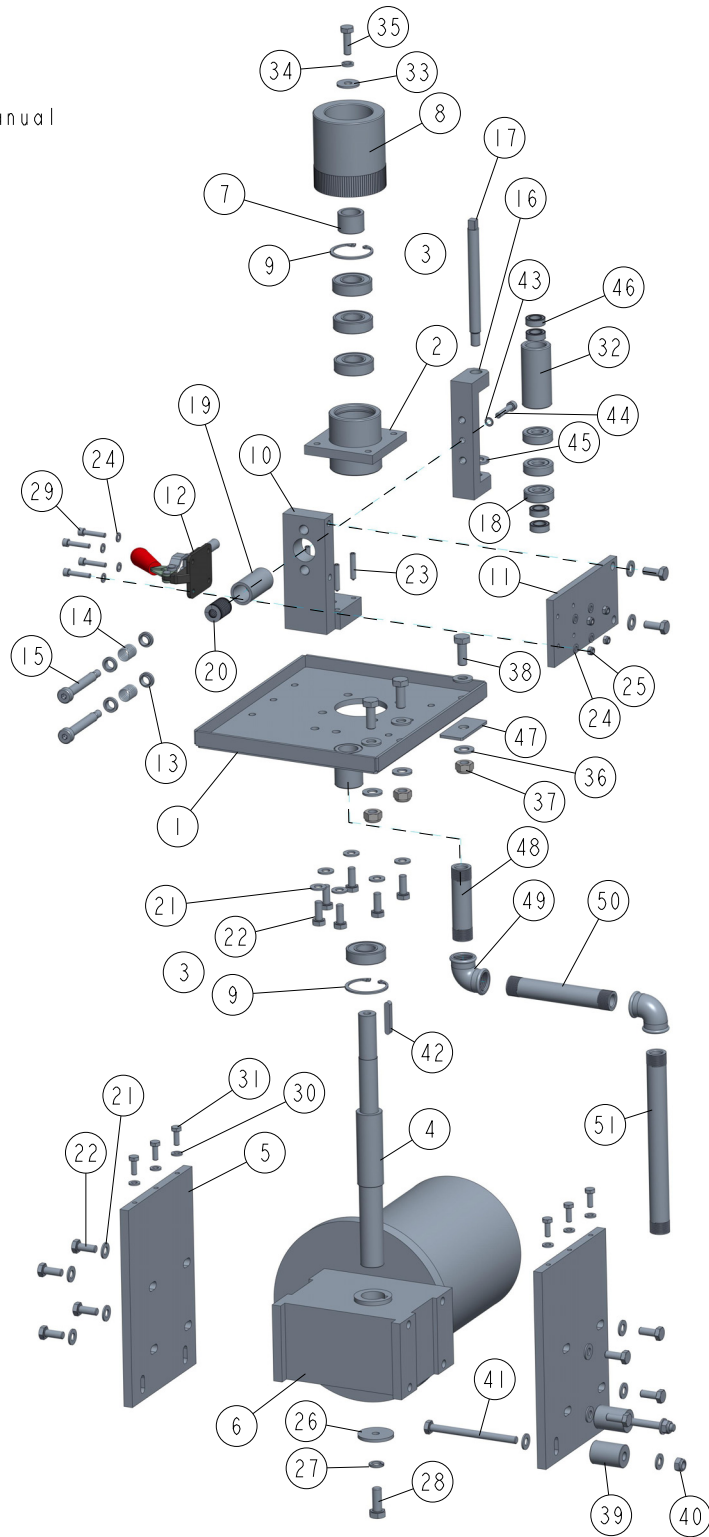

REF	DESCRIPTION (u indicates parts available in assemblies only)	PART #	QTY
-	BLADE DRIVE ASSEMBLY	510735	1
1	PLATE, MOUNTING	095762-1	1
2	BODY, BEARING WLDMT/PTD	095765-1	1
3	BEARING, 6004 2RS CX ROLLING	093868	4
4	SHAFT, WS DRIVE	510743	1
5	PLATE, MOTOREDUCER MOUNTING	095624	2
6	MOTOREDUCER, SEMKH80-4B/XL50-25S	095558	1
7	BUSHING, 20X28X13 SPACER	095767	1
8	ROLLER	510742	1
9	RING, W42 INSIDE RETAINING	F81090-51	2
10	BRACKET, CLAMP WLDMT/PTD	510738-1	1
11	PLATE, CLAMP MOUNTING	095774	1
12	CLAMP, 603-M DE-STA-CO SHARPENER	087468	1
13	WASHER	095771	4
14	SPRING, WASH CLAMP RETRACT	050472	2
15	BOLT, 10/M8X60-12.9 ISO7379/BN1359 BOSSA	F81003-79	2
16	BRACKET, BEARING	510737	1
17	SHAFT, BLADE CLAMP ROLLER	510785	1
18	BEARING, 6201 2RS	089060	3
19	GUIDE, BEARING BRACKET	095773	1
20	SPRING, WASH CLAMP TENSION	050471	1
21	WASHER, 8.4 FLAT ZINC	F81054-1	20
22	BOLT, M8X20-8.8 HEX HEAD FULL THREAD ZIN	F81002-1	16
23	SCREW, M6X30-33H GEOMET HEX SOCKET SET	F81001-29	4
24	WASHER, 5.3 FLAT ZINC	F81052-1	8
25	NUT, M5-8 DIN985 ZINC	F81030-2	4
26	WASHER, .313X1.5X.125	S08220	1
27	WASHER, Z 10.2 SPLIT LOCK ZINC	F81055-2	1
28	BOLT, M10X25 8.8 HEX HEAD FULL THREAD ZI	F81003-11	1
29	SCREW, M5X25 8.8 HEX SOCKET HEAD CAP ZIN	F81000-7	4
30	WASHER, STAINLESS STEEL, 6.4 DIN 125/ISO	F81053-5	6
31	BOLT, M6X16 DIN933/ISO4017 A2 STAINLESS	F81001-39	6
32	ROLLER, BLADE CLAMP ASSEMBLY	510741	1
33	WASHER, 8.5 SPECIAL FLAT ZINC	F81054-11	1
34	WASHER 8,2 SPLIT LOCK ZINC	F81054-4	1
35	BOLT, M8X25-8.8-B HEX HEAD FULL THREAD Z	F81002-5	1
36	WASHER, 10.5 FLAT ZINC	F81055-1	6
37	NUT, M10-8-B HEX NYLON ZINC LOCK	F81033-1	3
38	BOLT, M10X25 8.8 HEX HEAD FULL THREAD	F81003-31	3
39	BUSHING, N9XN25X35 SPACER	095959-1	2
40	NUT, M8-8-B HEX NYLON ZINC LOCK	F81032-2	2
41	BOLT, M8X100-8.8 HEX HEAD ZINC	F81002-23	2

5**Wash Station Parts***Blade Drive Assembly*

REF	DESCRIPTION (u indicates parts available in assemblies only)	PART #	QTY	
42	KEY, A6X6X36 PN-70/M85005 PARALLEL	510786	1	
43	WASHER, Z 6.1 SPLIT LOCK	F81053-3	1	
44	SCREW, M6X30-8.8 HEX SOCKET HEAD CAP ZIN	F81001-42	1	
45	WASHER, 13 FLAT ZINC	F81056-1	1	
46	BEARING, BALL (63801-2RS)	543381	4	
47	PLATE	543941-1	1	
48	FITTING, 1/2" -80MM THREAD ZINC-PLATED	511417	1	
49	ELBOW, 1/2" ZINC-PLATED	511419	2	
50	FITTING, ZINC THREAD. 1/2" - 120MM(4.75"	511418	1	
51	FITTING, ZINC THREAD 1/2" - 200MM	511421	1	

5.6 Blade Support Arms

BWS_005
510750_Manual

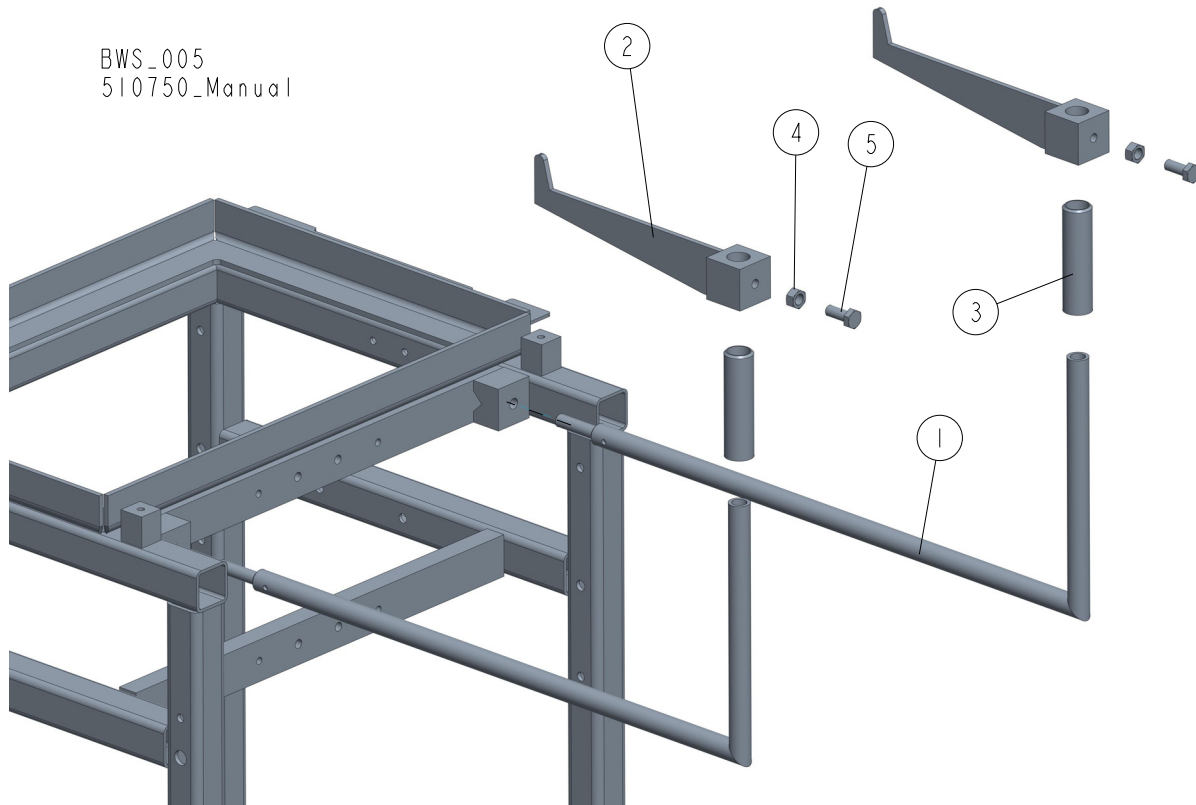

REF	DESCRIPTION (◆ indicates parts available in assemblies only)	PART #	QTY	
1	PIPE, SUPPORT	087584-1	2	
2	REST, REAR BLADE SUPPORT	087589-1	2	
3	PIPE, BLADE WEAR REAR	087590	2	
4	NUT, M10-8-B-HEX ZINC	F81033-3	2	
5	BOLT, M10X25 8.8 HEX HEAD FULL THREAD ZI	F81003-11	2	

5.7 Pre-Cleaning Assembly

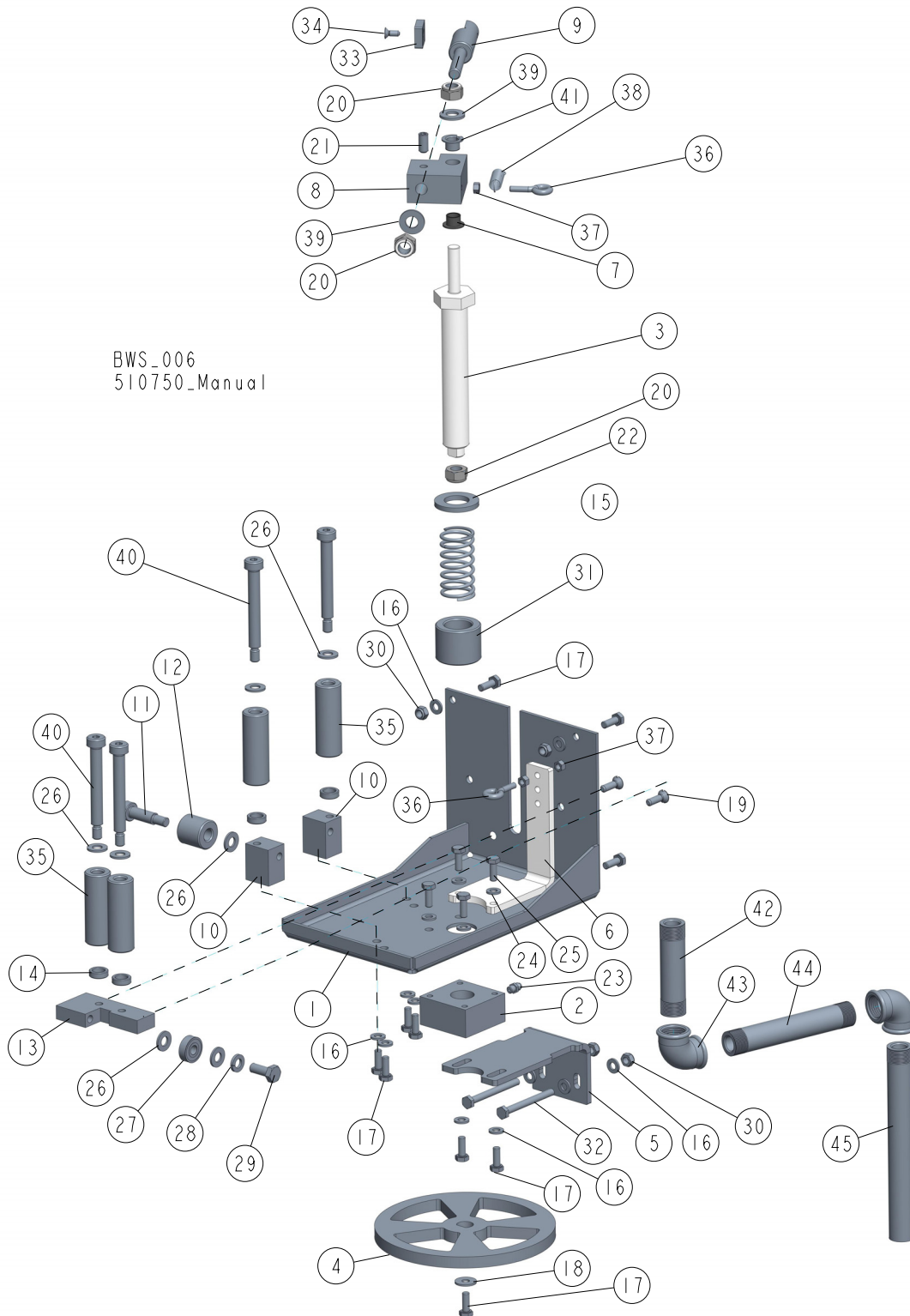

REF	DESCRIPTION (◆ indicates parts available in assemblies only)	PART #	QTY	
1	PRE-CLEANING ASSEMBLY	510789	1	
1	PLATE, MOUNTING COMPLETE	510791	1	
2	BLOCK, THREADED	095617	1	
3	BOLT, DEBURR BAR	511017-1	1	
4	WHEEL, HEIGHT ADJUSTMENT	095614	1	
5	BRACKET, LOWER	095620-1	1	
6	BRACKET, SPRING	511021-1	1	
7	BUSHING, XFM-1012-09 (IGUS)	093822	2	
8	BRACKET, DEBURR BAR	511024-1	1	
9	BAR, DEBURR ZINC-PLATED	100829-1	1	
10	BLOCK, BEARING MOUNTING	095615	2	
11	BOLT, 10/M8X25 12.9 ISO7379 SHOULDER	F81003-77	1	
12	ROLLER, BLADE LOWER	095623	1	
13	BRACKET, REAR BLADE ROLLER	095573	1	
14	BUSHING, BEARING SPACER	095574-1	4	
15	SPRING, WASH CLAMP TENSION	050721	1	
16	WASHER, 6.4 ZINC FLAT	F81053-1	14	
17	BOLT, M6X16 8.8 HEX HEAD FULL THREAD ZIN	F81001-15	11	
18	WASHER, 6.5 ZINC SPECIAL FLAT	F81053-11	1	
19	SCREW, M6X20-5.8-B SLOTTED COUNTERSUNK H	F81001-31	2	
20	NUT, M10-8-B HEX NYLON ZINC LOCK	F81033-1	3	
21	SCREW, M8X16-33H ZINC HEX SOCKET SET FLA	F81014-2	1	
22	WASHER, 21 FLAT ZINC	F81059-2	1	
23	GREASE, M6 TYP A FITTING	086280	1	
24	WASHER, STAINLESS STEEL, 6.4 DIN 125/ISO	F81053-5	4	
25	BOLT, M6X16 DIN933/ISO4017 A2 STAINLESS STEEL	F81001-39	4	
26	WASHER, 8.4 FLAT,ZINC	F81054-1	7	
27	BEARING, 608-2RS ROLLER	086197	1	
28	WASHER, SPLIT LOCK 8.1 DIN127 A2 SS	F81054-6	1	
29	BOLT, M8X20 DIN933 A2-70. SS	F81002-34	1	
30	NUT, M6-8-B NYLON HEX ZINC LOCK	F81031-2	6	
31	BUSHING, SPACER 38/23-30	511020-1	1	
32	BOLT, M6X60-8.8 HEX HEAD FULL THREAD ZINC	F81001-9	2	
33	PLATE, SNMG190612 CARBIDE CUTTING	100832	1	
34	SCREW, M5X12- 5.8-B SLOTTED COUNTERSUNK HEAD ZINC	F81000-15	1	
35	ROLLER, BLADE GUIDE	511026	4	
36	BOLT, M5X15 BN1006 (BOSSARD) TURNED EYE	F81000-30	2	
37	NUT, M5-8 HEX ZINC	F81030-1	3	
38	SPRING, 1.6X12X38 EXTENSION	092208	1	
39	WASHER, 10.5 FLAT ZINC	F81055-1	2	
40	BOLT, 10/M8X70-12.9 ISO7379/BN1359 BOSSA	F81003-96	4	
41	BEARING, TUF1 10.090 (CX)	099074	1	

5 Wash Station Parts

Pre-Cleaning Assembly

REF	DESCRIPTION (◆ indicates parts available in assemblies only)	PART #	QTY	
42	FITTING, 1/2" -80MM THREAD ZINC-PLATED	511417	1	
43	ELBOW, 1/2" ZINC-PLATED	511419	2	
44	FITTING, ZINC THREAD. 1/2" - 120MM(4.75")	511418	1	
45	FITTING, ZINC THREAD. 1/2" - 170MM (6.7")	511422	1	

5.8 Upper tank

BWS_007
510750_Manual

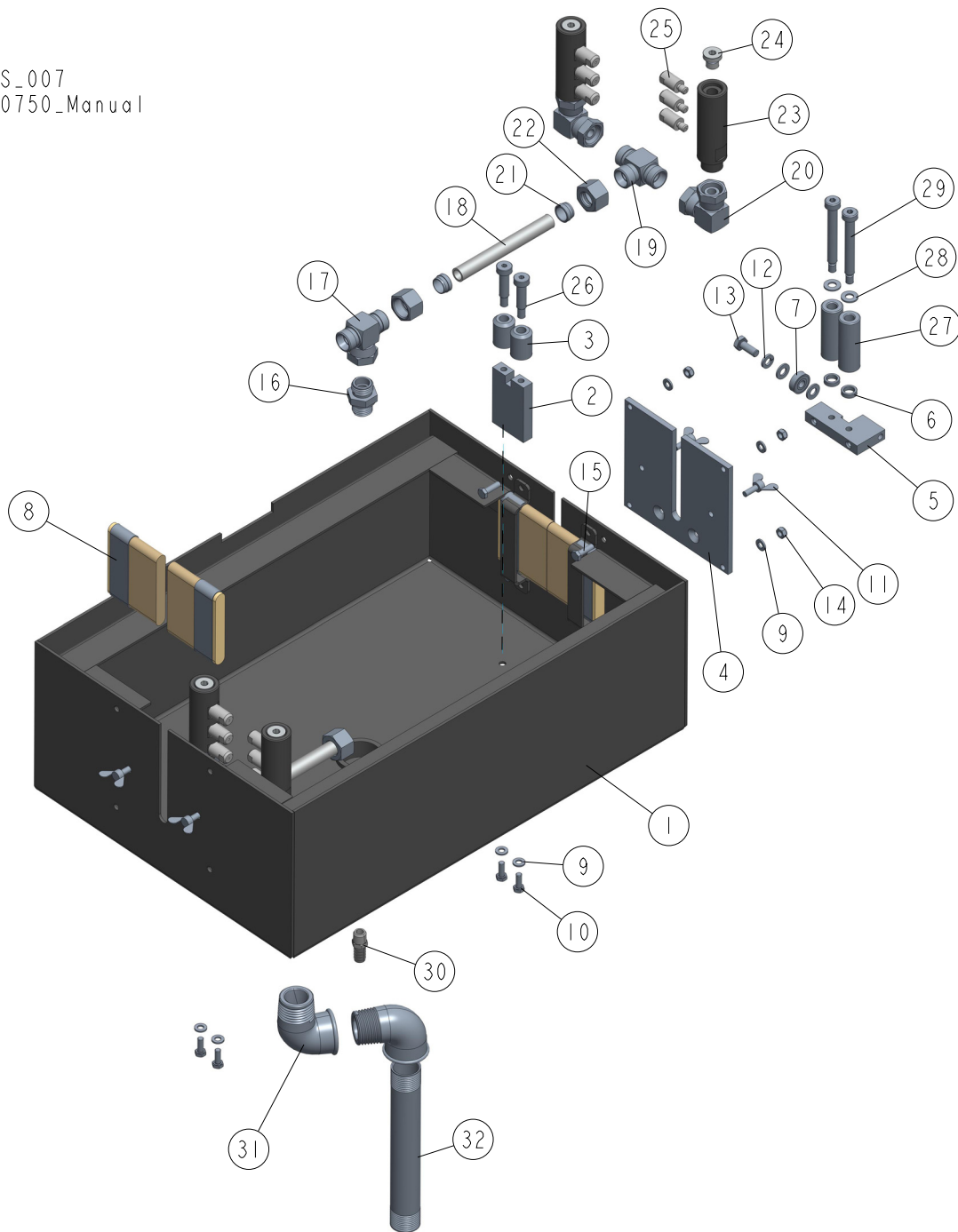

REF	DESCRIPTION (◆ indicates parts available in assemblies only)	PART #	QTY
-	UPPER TANK, COMPLETE	510744	1

5

Wash Station Parts

Upper tank

REF	DESCRIPTION (◆ indicates parts available in assemblies only)	PART #	QTY	
1	TANK, UPPER	510745	1	
2	BLOCK, ROLLER	095571	2	
3	ROLLER, WASH STATION GUIDE	095570	4	
4	PLATE, ROLLER ASSEMBLY LEFT MOUNTING	510749	1	
5	BRACKET, REAR BLADE ROLLER	095573	1	
6	BUSHING, BEARING SPACER	095574-1	2	
7	BEARING, 608-2RS ROLLER	086197	1	
8	CLEANER, BLADE	087603	4	
9	WASHER, 6.4 ZINC FLAT	F81053-1	8	
10	BOLT, M6X16 DIN933/ISO4017 A2 STAINLESS	F81001-39	4	
11	SCREW, M6 X 16 THUMB	F81001-16	4	
12	WASHER, SPLIT LOCK 8.1 DIN127 A2 SS	F81054-6	1	
13	BOLT, M8X20 DIN933 A2-70. SS	F81002-34	1	
14	NUT, M6-8-B NYLON HEX ZINC LOCK	F81031-2	4	
15	BOLT, M6X20 8.8 HEX HEAD FULL THREAD ZIN	F81001-2	4	
16	FITTING, GZ-M22X1.5/GZ-1/2-14BSP	510958	1	
17	FITTING, XEVT 15 L 22X1.5 TEE W/NUT	509688	1	
18	PIPE, WASH	510960	2	
19	T-FITTING, M22X1.5	510961	2	
20	FITTING, 90DEG. M22X1.5 ELBOW	510962	4	
21	SLEEVE, DPR 15 L. PIPE CLINCH	509697	4	
22	NUT, M 15 L M22X1.5	509690	4	
23	SLEEVE, SPRAY NOZZLE	510963	4	
24	CAP, 1/4" BSP SPRAY NOZZLE SLEEVE	510965	4	
25	NOZZLE, 2MM SPRAY	511025	12	
26	BOLT, 10/M8X30 12.9 ISO 7379 SHOULDER	F81003-81	4	
27	ROLLER, BLADE GUIDE	511026	2	
28	WASHER, 8.4 FLAT,ZINC	F81054-1	4	
29	BOLT, 10/M8X70-12.9 ISO7379/BN1359 BOSSA	F81003-96	2	
30	FITTING, R1/4Z STRAIGHT THREADED (HOSE 1	535586	1	
31	FITTING, WZ 1" ELBOW ZINC	511420	2	
32	FITTING, ZINC THREAD 1" - 200MM	511423	1	

5.9 Drive Lid Bracket

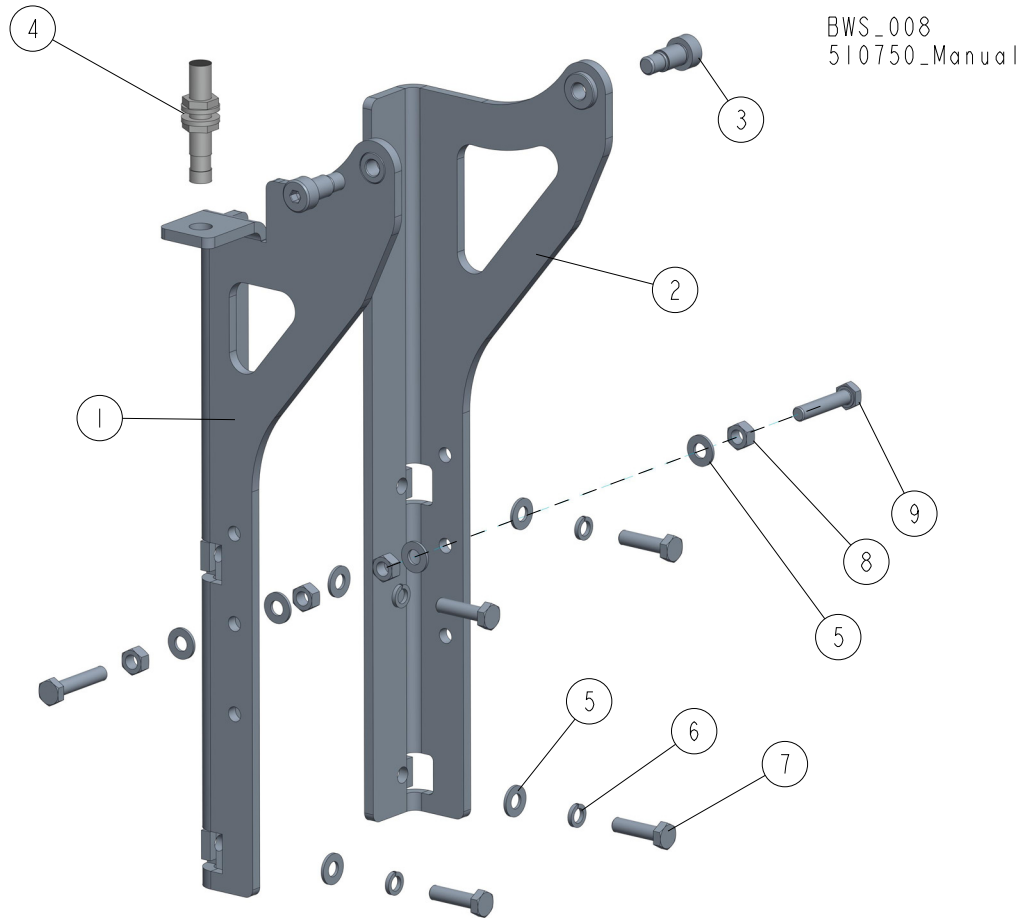

REF	DESCRIPTION (◆ indicates parts available in assemblies only)	PART #	QTY
1	DRIVE BRACKET - RIGHT	510798-1	1
2	DRIVE BRACKET - LEFT	510799-1	1
3	BOLT, 12/M10X16 12.9 ISO7379/BN1359 BO	F81003-64	2
4	SENSOR, BES M12MI-PSC40B-S04G INDUCTIVE	093172	1
5	WASHER, 8.4 FLAT,ZINC	F81054-1	8
6	WASHER 8,2 SPLIT LOCK ZINC	F81054-4	4
7	BOLT, M8X30 8.8 HEX HEAD FULL THREAD ZIN	F81002-7	4
8	NUT, M8-8-B HEX ZINC	F81032-1	4
9	BOLT, M8X40-8.8 HEX HEAD FULL THREAD ZINC	F81002-15	2

5.10 Drive Lid Assembly

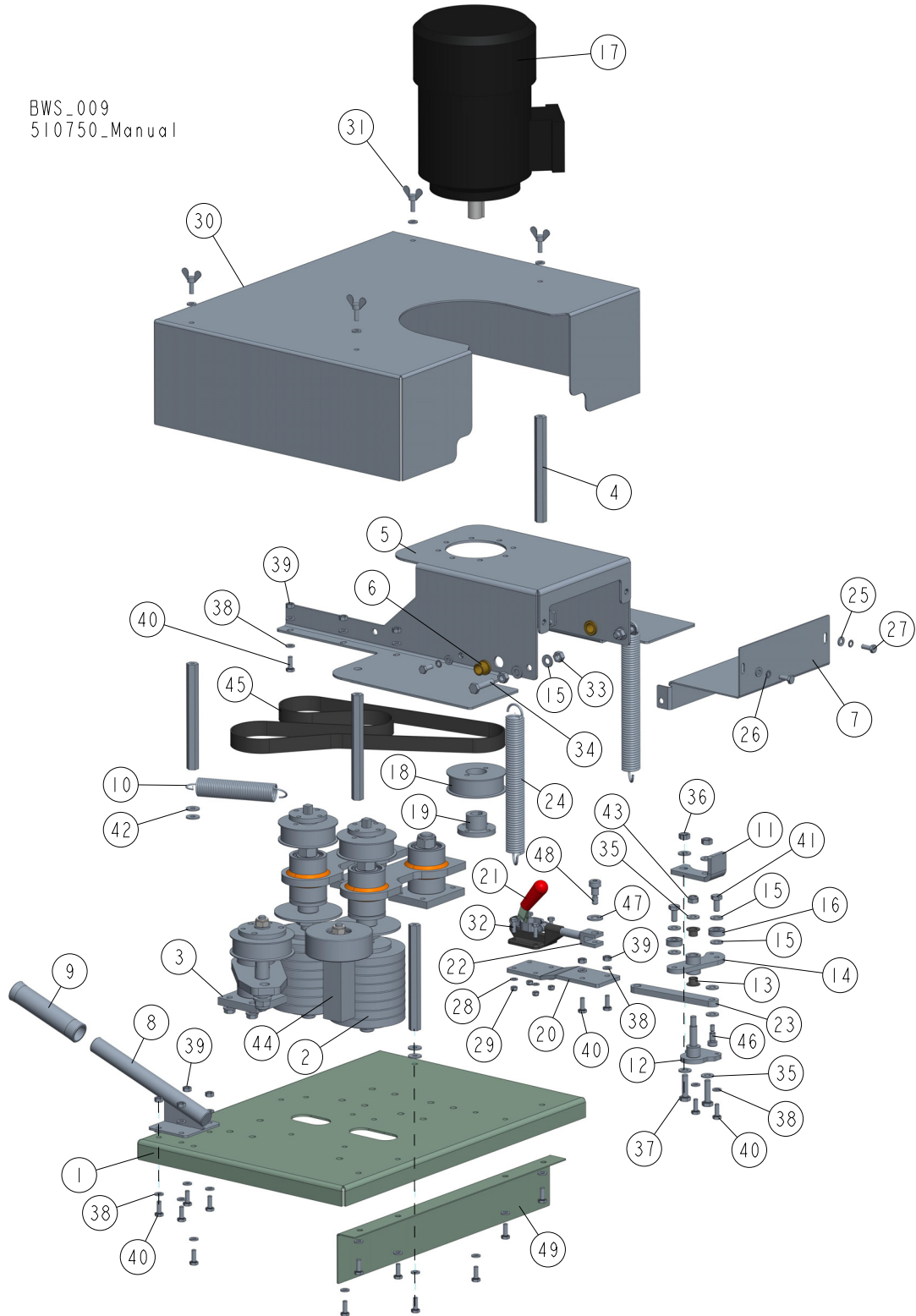

Wash Station Parts

Drive Lid Assembly

5

REF	DESCRIPTION (◆ indicates parts available in assemblies only)	PART #	QTY
-	DRIVE LID ASSEMBLY	510751	1
1	PLATE, DRIVE LID MOUNTING	510792	1
2	BRUSH ARM, COMPLETE See Section 5.11	510752	2
3	TENSIONING ROLLER ARM, COMPLETE See Section 5.12	095592	1
4	NUT, M6 L=145	095594	4
5	BASE, DRIVE MOTOR COMPLETE	510793-1	1
6	BUSHING	510787	2
7	COVER, DRIVE REAR COMPLETE	510800-1	1
8	HANDLE, WLDMT/PTD	095600-1	1
9	GRIP	086164	1
10	SPRING, 1.0 OD X .095 WIRE X 4.0 L	035814	1
11	BAR, LIMIT SWITCH FLAT	095602	1
12	CLAMP, AXLE WLDMT/PTD	095606-1	1
13	BUSHING, XFM-1012-09 (IGUS)	093822	2
14	PLATE, CLAMP PIVOT WLDMT/PTD	511002-1	1
15	WASHER, 8.4 FLAT,ZINC	F81054-1	8
16	BEARING, 608-2RS ROLLER	086197	2
17	MOTOR, SEMKH80-4CF2	095499	1
18	PULLEY, 24 TOOTH X3/4 STB GEARBELT	031393	1
19	BUSHING, 5/8 KEYED BORE SPLIT TAPER H	030361	1
20	BRACKET, CLAMP	095612	1
21	CLAMP, 603-M DE-STA-CO SHARPENER	087468	1
22	PIVOT, PUSHER	543911	1
23	PUSHER, PIVOT PLATE	511016-1	1
24	SPRING, 1.0 OD X .115 WIRE X 6-1/2L	035858	2
25	WASHER, 6.4 ZINC FLAT	F81053-1	8
26	WASHER, Z 6.1 SPLIT LOCK	F81053-3	4
27	BOLT, M6X16 8.8 HEX HEAD FULL THREAD ZIN	F81001-15	4
28	WASHER, 5.3 FLAT ZINC	F81052-1	4
29	NUT, M5-8 SELF-LOCKING ZINC	F81030-2	4
30	GUARD, DRIVE UPPER	095557	1
31	SCREW, M6 X 16 THUMB	F81001-16	4
32	BOLT, M5X16-5.8 HEX HEAD FULL THREAD ZIN	F81000-51	4
33	NUT, M8-8-B HEX ZINC	F81032-1	4
34	BOLT, M8X35-8.8 ZINC HEX HEAD FULL THREA	F81002-13	2
35	WASHER, STAINLESS STEEL 8.4 DIN125 A2	F81054-7	7
36	NUT, M8 DIN 934 A2-70 STAINLESS STEEL	F81032-7	2
37	BOLT, M8X30 DIN933 A2-70 STAINLESS STEEL	F81002-27	2
38	WASHER, STAINLESS STEEL, 6.4 DIN 125/ISO	F81053-5	26
39	NUT, STAINLESS STEEL, M6 DIN 934/ISO 403	F81031-6	11
40	BOLT, M6X16 DIN933/ISO4017 A2 STAINLESS	F81001-39	17
41	BOLT, STAINLESS STEEL M8X16 DIN933 A2-70	F81002-35	2

5**Wash Station Parts***Drive Lid Assembly*

REF	DESCRIPTION (◆ indicates parts available in assemblies only)	PART #	QTY	
42	WASHER, 6.5 ZINC SPECIAL FLAT	F81053-11	4	
43	NUT, M8-8-B HEX NYLON ZINC LOCK	F81032-2	1	
44	BELT TENSION WHEEL ASSEMBLY See Section 5.13	096094	1	
45	BELT , 3/8 PITCH X 3/4 X 48 DUAL DRIVER	035857	1	
46	BOLT, 8/M6X12-12.9 ISO 7379 SHOULDER	F81001-56	1	
47	WASHER, 10.5 FLAT ZINC	F81055-1	1	
48	BOLT, 10/M8 X 12-12.9 ISO-7379	F81003-62	1	
49	GUARD, SPLASH	520427	1	

5.11 Brush Arm

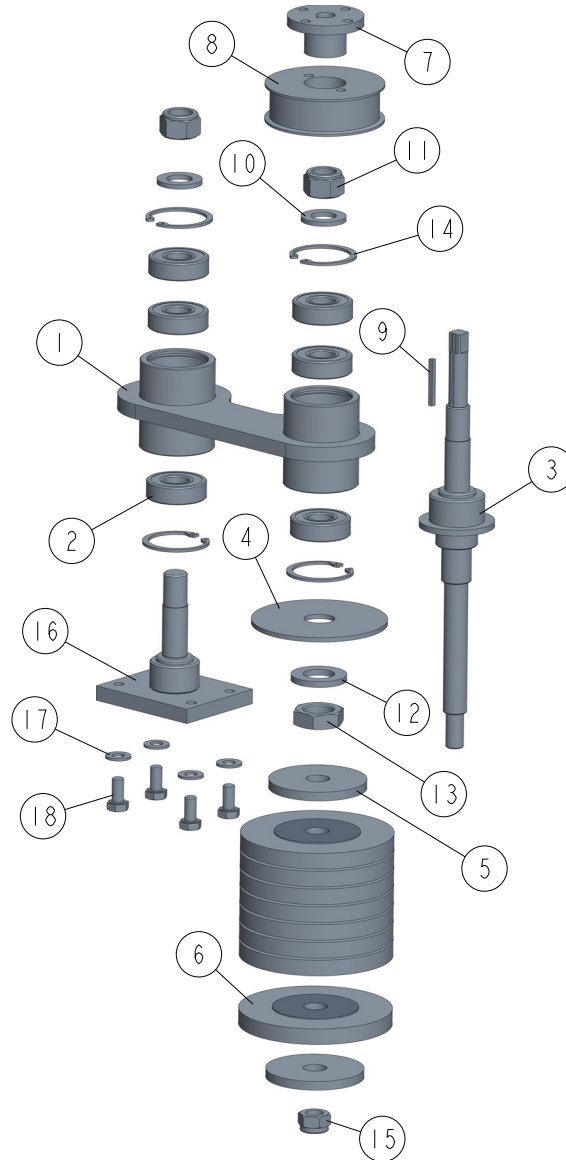

BWS_010
510750_Manual

REF	DESCRIPTION (◆ indicates parts available in assemblies only)	PART #	QTY
-	BRUSH ARM, COMPLETE	510752	1
1	WELDMENT, BRUSH HEAD	095585	1
2	BEARING, 6203-2RS FLT ROLLING	086114	6
3	SPINDLE, BRUSH	510753	1
4	PLATE, SLINGER	095586	1
5	WASHER, BRUSH	095587	2
6	BRUSH, 4" STAINLESS STEEL WIRE	P31033	8

5**Wash Station Parts***Brush Arm*

REF	DESCRIPTION (◆ indicates parts available in assemblies only)	PART #	QTY	
7	BUSHING, H1/2 KEYED BORE SPLIT TAPER	031392	1	
8	PULLEY, 24 TOOTH X3/4 STB GEARBELT	031393	1	
9	KEY,1/8X1 1/4 BRUSH DRIVE	031390	1	
10	WASHER, 17 FLAT ZINC	F81058-1	2	
11	NUT, M16-8 HEX NYLON ZINC LOCK	F81036-2	2	
12	WASHER, 21 FLAT ZINC	F81059-2	1	
13	NUT, M20X1,5 THIN	F81037-7	1	
14	RING, W40 INSIDE RETAINING	F81090-3	4	
15	NUT, M12 8 HEX NYLON ZINC LOCK	F81034-2	1	
16	AXLE, SHORT WLDMT/PTD	095582	1	
17	WASHER, STAINLESS STEEL 8.4 DIN125 A2	F81054-7	4	
18	BOLT, STAINLESS STEEL M8X16 DIN933 A2-70	F81002-35	4	

5.12 Tensioning Roller Arm

BWS_011
 510750_Manual

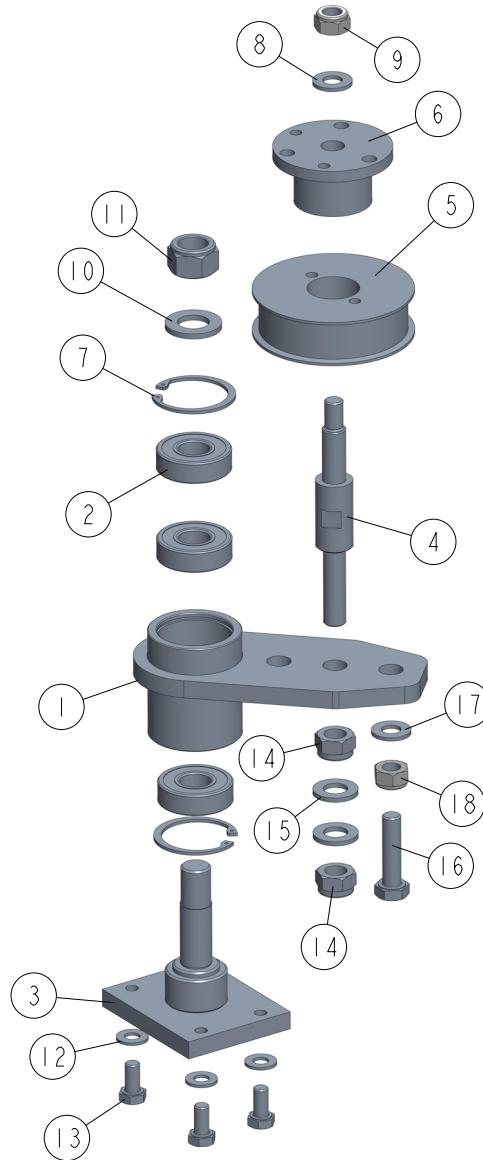

REF.	DESCRIPTION (* Indicates Parts Available In Assemblies Only)	PART #	QTY
	TENSIONING ROLLER ARM, COMPLETE	095592	1
1	ARM, TENSIONING ROLLER WLDMT.	095591	1
2	BEARING, 6203-2RS	086114	3
3	AXLE, SHORT WLDMT/PTD	095582	1
4	AXLE, GEARBELT PULLEY	511013	1
5	PULLEY, 26 TOOTH X3/4 STB GEARBELT	031391	1
6	IDLER BUSHING,1PH 1-1/2	P31040	1
7	RING, W40 SPRING RETAINING	F81090-3	2

5 Wash Station Parts
Tensioning Roller Arm

REF.	DESCRIPTION (* Indicates Parts Available In Assemblies Only)	PART #	QTY	
8	WASHER, 10.5 FLAT ZINC	F81055-1	1	
9	NUT, M10-8-B HEX NYLON ZINC LOCK	F81033-1	1	
10	WASHER, 17 FLAT ZINC	F81058-1	1	
11	NUT, M16,HEX, NYLON ZINC LOCK	F81036-2	1	
12	WASHER, STAINLESS STEEL 8.4 DIN125 A2	F81054-7	3	
13	BOLT, STAINLESS STEEL M8X16 DIN933 A2-70.	F81002-35	3	
14	NUT, M12-8 HEX NYLON ZINC LOCK	F81034-2	2	
15	WASHER, 13 FLAT ZINC	F81056-1	2	
16	BOLT, M10 X 40-8.8 HEX NYLON ZINC LOCK	F81003-16	1	
17	WASHER, 10.5 FLAT ZINC	F81055-1	1	
18	NUT, M10-8-B HEX NYLON ZINC LOCK	F81033-1	1	

5.13 Belt Tension Wheel Assembly

BWS_012
 510750_Manual

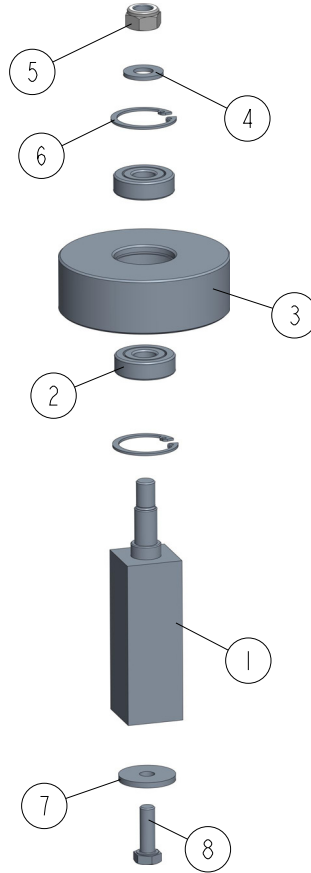

REF.	DESCRIPTION (* Indicates Parts Available In Assemblies Only)	PART #	QTY
	BELT TENSION WHEEL ASSEMBLY	096094	1
1	AXLE, BELT TENSION WHEEL	511005-1	1
2	BEARING, 6201 2RS	089060	2
3	WHEEL, BELT TENSION	096092	1
4	WASHER, 10.5 FLAT ZINC	F81055-1	1
5	NUT, M10-8-B HEX NYLON ZINC LOCK	F81033-1	1
6	RING, 32W INTERIOR RETAINING	F81090-5	2
7	WASHER, SPECIAL 30/8.1X3	511004	1
8	BOLT, M8X25 DIN933 A2-70 STAINLESS STEEL	F81002-26	1

5.14 Wash Station Decals

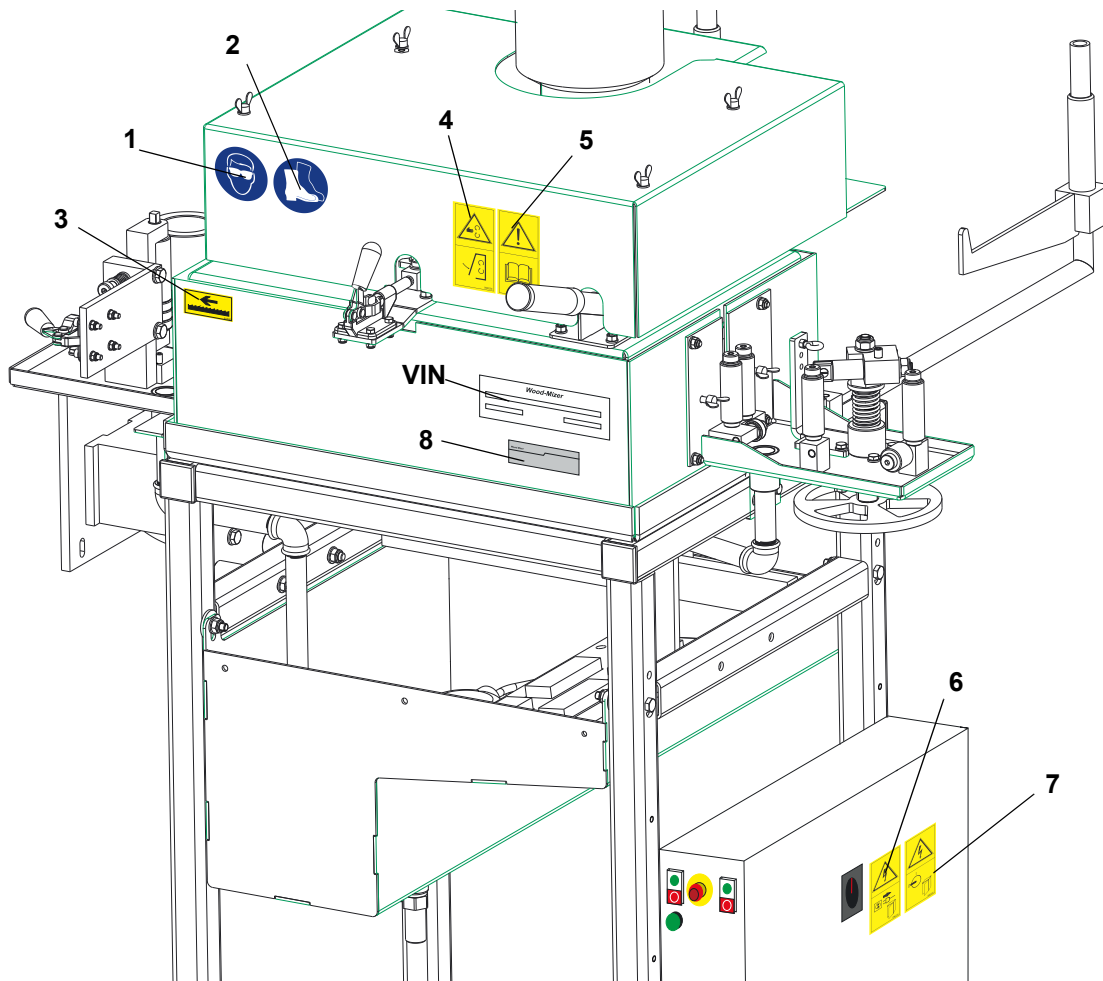

REF.	DESCRIPTION (* Indicates Parts Available In Assemblies Only)	PART #	QTY
	PICTOGRAPHIC DECAL KIT, WASH STATION	519100	1
1	DECAL, EYE PROTECTION WARNING (PICTOGRAM)	S12004G	1
2	DECAL, USE SAFETY BOOTS (PICTOGRAM)	501465	1
3	DECAL, BLADE MOVEMENT DIRECTION (PICTOGRAM)	519060	1
4	DECAL, CLOSE GUARDS BEFORE OPERATING	099220	1
5	DECAL, READ MANUAL BEFORE OPERATING	096317	1
6	DECAL, REMOVE THE PLUG BEFORE OPENING THE BOX (PICTOGRAM)	096319	1
7	DECAL, HIGH VOLTAGE INSIDE THE ELECTRIC BOX (PICTOGRAM)	096316	1
8	DECAL, EUROPEAN HEADQUARTERS ADDRESS	015841	1

SECTION 6 ELECTRICAL INFORMATION

6.1 Electrical Symbol Diagram

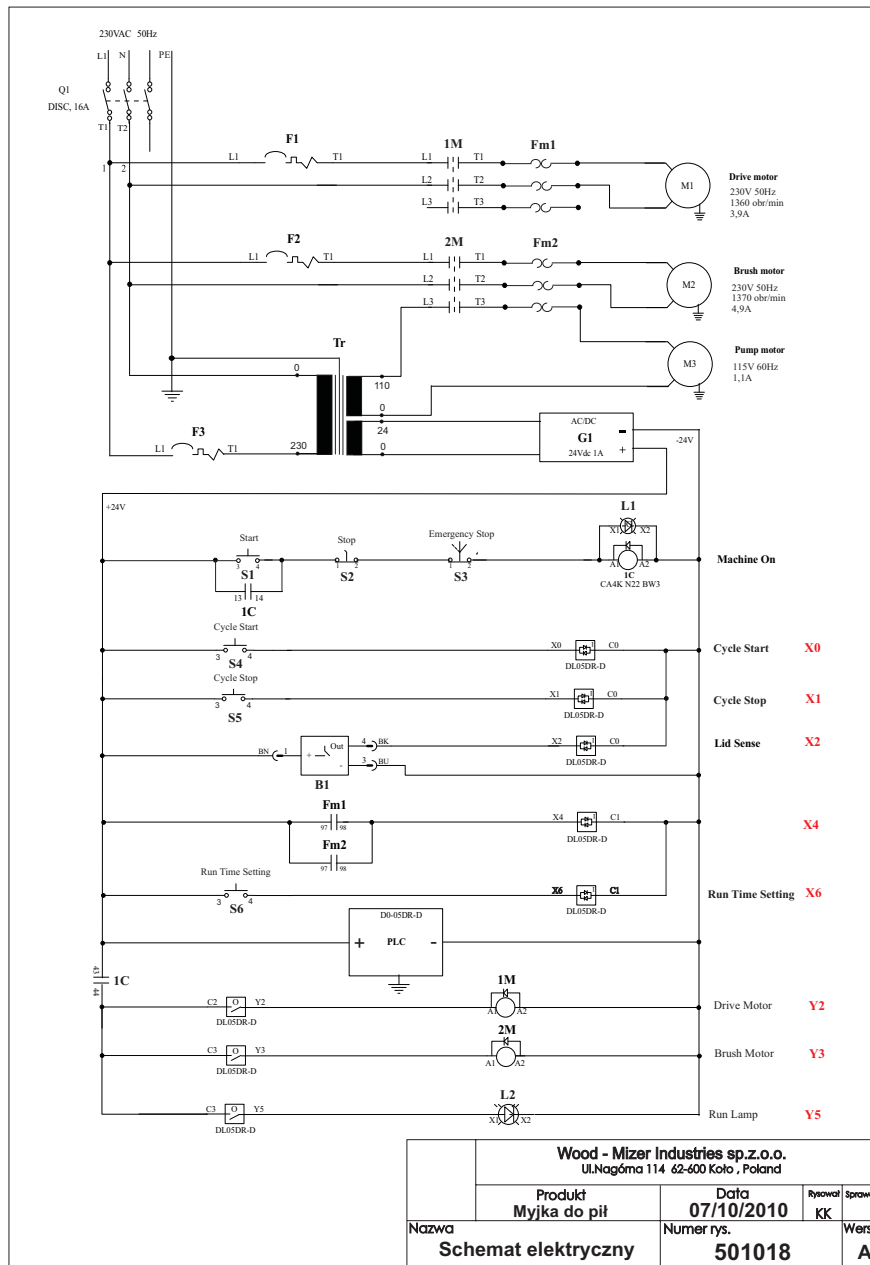

FIG. 6-1

6.2 Electrical Components

LP.	OZNACZENIE	NAZWA-TYP	PRODUCENT	NR SYTE-LINE
1	F1, F2	wyłącznik modułowy iC60N 1P 6A D	SCHNEIDER ELECTRIC	
2	F3	wyłącznik modułowy iC60N 1P 2A C	SCHNEIDER ELECTRIC	088278
3	Q1	wyłącznik ABB OT16F3	ABB	503541
4	1M, 2M	stycznik LC1 D09 BD	SCHNEIDER ELECTRIC	092477
5	1C	stycznik CA4KN31 BW3	SCHNEIDER ELECTRIC	092479
6	PLC	Sterownik PLC DO-05 DR-D	AUTOMATION DIRECT	088425
7	G1	Stabilizator 24V 1A		090428
8	B1	Czujnik indukcyjny BES M12MI- PSC40B-S04G	BALLUFF	093172
9	Fm1, Fm2	Przełącznik termiczny LRD 10	SCHNEIDER ELECTRIC	095841
10	L1	lampka kontrolna M22 BIAŁA	MOELLER	090448
11	S1, S2, S4, S5	przycisk START/STOP M22	MOELLER	090452
12	S3	Wyłącznik awaryjny XB4BS542	SCHNEIDER ELECTRIC	086556
13	S6	Przycisk M22	MOELLER	093118
14	M1	Silnik napędu posuwu SEMkh80-4B	BESEL	095558
15	M2	Silnik napędu szczotek SEMh80- 4CF2	BESEL	095499
16	M3	Pompa wodna	GIANT	P09836
17	Tr	Transformator SU96C-230311	NORATEL	500631