

G15 Engine

Safety, Operation, Maintenance & Parts Manual

LT15

rev. B4.00



Safety is our #1 concern! Read and understand all safety information and instructions before operating, setting up or maintaining this machine.

August 1997

Form #698

SECTION 1	SAFETY & GENERAL INFORMATION	1-1
1.1	Refueling	1-2
1.2	Engine Operation.....	1-2
SECTION 2	OPERATION	2-1
2.1	Starting The Engine.....	2-1
SECTION 3	MAINTENANCE	3-1
3.1	Air Filter & Pre-Cleaner.....	3-1
3.2	Engine Oil & Filter.....	3-2
3.3	Air Cooling System.....	3-2
3.4	Fuel Filter	3-2
3.5	Miscellaneous Maintenance	3-2
3.6	Drive Belt Adjustment.....	3-3
3.7	RPM Adjustments	3-5
SECTION 4	REPLACEMENT PARTS	4-1
4.1	How To Use The Parts List	4-1
4.2	Sample Assembly	4-1
4.3	Engine Assembly.....	4-2
4.4	Throttle/Tensioner Assembly	4-4

SECTION 1 SAFETY & GENERAL INFORMATION



IMPORTANT! This manual is provided as a supplement to the equipment manufacturer's manuals. This manual takes into account the specific use of engines on the Wood-Mizer sawmill. Only safety, maintenance, and operating procedures that are not provided by the manufacturer are supplied in this manual. Refer to the manufacturer's manual before attempting to operate this equipment.



This symbol calls your attention to instructions concerning your personal safety. Be sure to observe and follow these instructions. This symbol accompanies a signal word. The word **DANGER** indicates an imminently hazardous situation which, if not avoided, will result in death or serious injury. **WARNING** suggests a potentially hazardous situation which, if not avoided, could result in death or serious injury. **CAUTION** refers to potentially hazardous situations which, if not avoided, may result in minor or moderate injury to persons or equipment. Read all safety instructions before operating this equipment and observe all safety warnings!

1 Safety & General Information

Refueling

1.1 Refueling



WARNING! Store gasoline away from sawdust and other flammable materials. Failure to do so may result in serious injury.

1.2 Engine Operation



DANGER! Always be sure the blade is disengaged and all persons are out of the path of the blade before starting the engine or motor. Failure to do so will result in serious injury.



WARNING! Do not for any reason adjust the engine drive belts or belt support bracket with the engine running. Doing so may result in serious injury.

WARNING! Remove the blade before performing any engine service. Failure to do so may result in serious injury.

WARNING! Always wear proper and necessary safety equipment when performing service functions. Proper safety equipment includes eye protection, breathing protection, hand protection and foot protection.



IMPORTANT! Always dispose of coolant, oil, fuel, oil filters and fuel filters in a responsible manner and in conformance with local, state and federal regulations.

SECTION 2 OPERATION

2.1 Starting The Engine

Engine Start



DANGER! Do not start the engine when the tensioner lever is in the engaged (up) position. Always be sure the blade is disengaged and all persons are away from the blade before starting the engine.

1. Turn the run/stop switch to the RUN position.

See Figure 2-1.

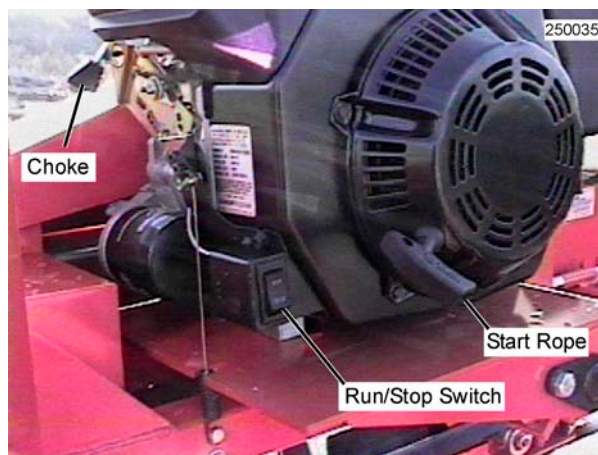

FIG. 2-1

2. Close the engine choke by moving the choke lever to the start position.



DANGER! Always be sure the blade is disengaged and all persons are out of the path of the blade before starting the engine or motor. Failure to do so will result in serious injury.

3. Pull the start rope slowly until you feel resistance, then pull the cord quickly to start the engine. Repeat with the choke opened slightly if necessary.
4. When the engine starts, slowly open the choke all the way by moving the choke lever to the off position.

For more information, see the engine manufacturer's operation manual.

2 **Operation** *Starting The Engine*

Engine Shutoff

1. Disengage the tensioner handle to stop the blade if necessary.
2. Let the engine run for 15 seconds with no load, then push the run/stop switch to STOP.

SECTION 3 MAINTENANCE



IMPORTANT! This manual only provides information about additional procedures or procedures to be performed at different time intervals than found in the engine manufacturer's manuals. Refer to the [manufacturer's manual](#) for complete maintenance instructions.



WARNING! Remove the blade before performing any engine service. Failure to do so may result in serious injury.



This symbol identifies the interval (hours of operation) which each maintenance procedure should be performed. "AR" signifies maintenance procedures which should be performed as required.

3.1 Air Filter & Pre-Cleaner



WARNING! Always wear proper and necessary safety equipment when performing service functions. Proper safety equipment includes eye protection, breathing protection, hand protection and foot protection.



Service the pre-cleaner every four hours of operation. Service by gently shaking excess sawdust and debris from the foam piece.



Clean the air filter (air cleaner element) and pre-cleaner (element wrapper) every eight hours of operation. See the engine manual for further instructions.



Replace the air filter (cleaner) every 200 hours of operation.



Replace the pre-cleaner (element wrapper) every 2000 hours of operation.

3.2 Engine Oil & Filter



Check the oil level every 8 hours of operation. Add oil as necessary. See the engine manual for oil viscosity and grade recommendations.



IMPORTANT! During initial break-in, change the oil and the oil filter after the first 5 hours and every 50 hours thereafter. Continue to check oil level every 8 hours of operation and refill as necessary.

3.3 Air Cooling System



Wash the engine or brush off sawdust and debris every 50 hours of operation. Clean the grass screen, cooling fins, and external surfaces. Remove any dust, dirt or oil. See engine manual for further instructions.

3.4 Fuel Filter



Replace the fuel filter every 100 hours of operation.

3.5 Miscellaneous Maintenance



Inspect the spark plugs every 100 hour of operation. Remove any deposits and adjust gap if necessary. See engine manual for further information.

3.6 Drive Belt Adjustment

 **WARNING!** Do not for any reason adjust the engine drive belts or belt support bracket with the engine running. Doing so may result in serious injury.

50

Check the drive belt tension after the first 20 hours, and every 50 hours thereafter.

To adjust the drive belt tension when the tensioner handle is disengaged:

1. Measure the distance from the blade housing to the drive belt with the tensioner handle disengaged as shown in Figure 3-1.
2. Adjust the distance by moving the engine assembly on the engine mount plate. To do that turn the two jam nuts on the turnbuckle counterclockwise to tighten the belt, clockwise to loosen the belt. Retighten the jam nuts.

See Figure 3-1.

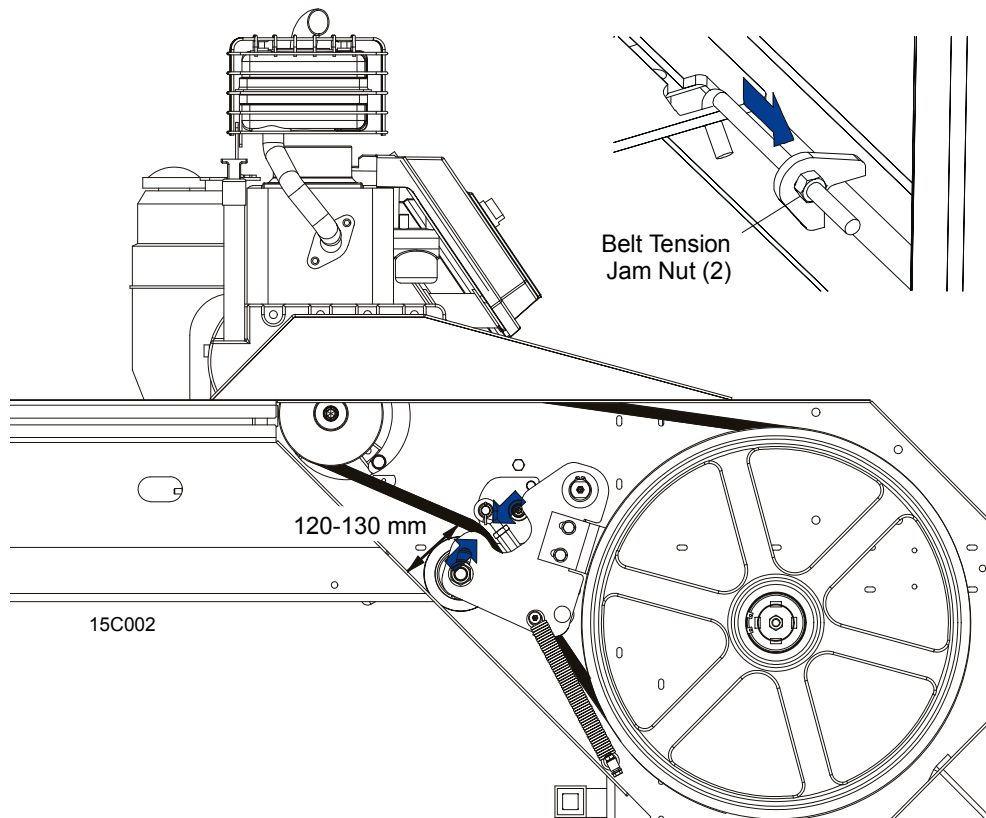

FIG. 3-1

To adjust the drive belt tension when the tensioner handle is engaged:

1. The drive belt tension is correct when you use 10 - 12 kG (100 - 120 N) of force to turn the tensioner handle to the up position. If you don't have a force gauge: the drive belt is too tight when you can feel vibrations while turning the tensioner handle in the up position. The drive belt is too loose when the engine pulley does not rotate the drive belt and the blade drive wheel when engaged.
2. Loosen the drive belt turnbuckle jam nut and turn the turnbuckle counterclockwise to tighten the belt, clockwise to loosen the belt.

See Figure 3-2.

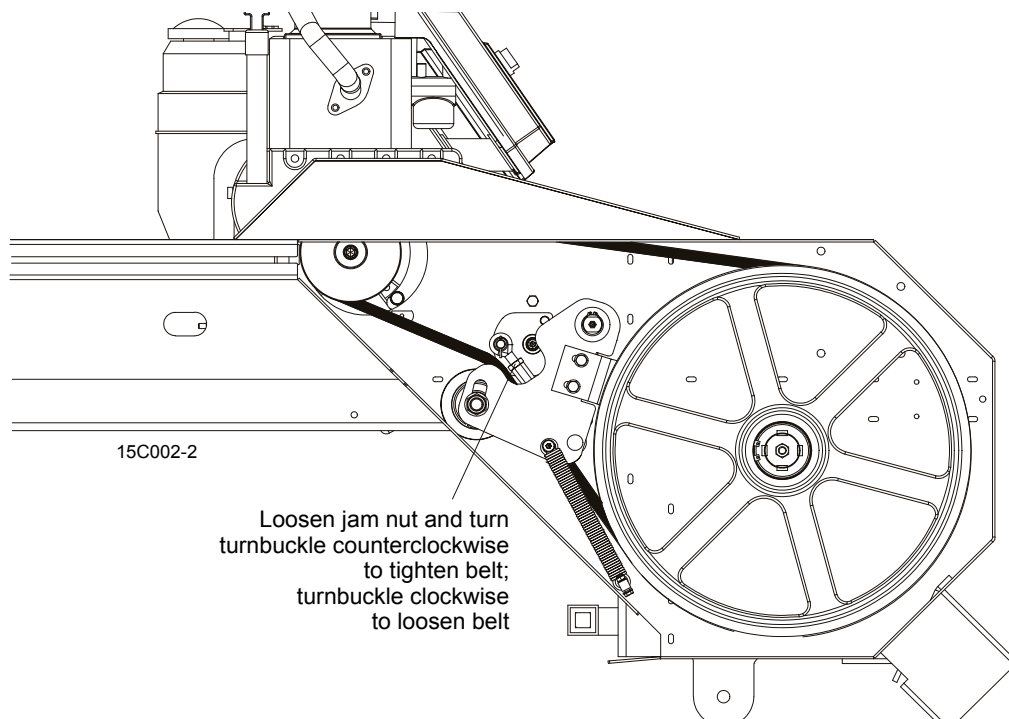

FIG. 3-2

After tensioning the drive belt, check throttle cable tension and adjust if necessary. Make sure that the throttle linkage is not affecting the engine RPM while the tensioner handle is disengaged. Make sure the cable is not bent or kinked. The throttle cable should be tensioned just enough so that the engine revs as soon as the tensioner handle is engaged. **NOTE:** A properly adjusted throttle will extend the cable spring 1/4" to 3/8" (6.4 - 9.5 mm) when running and have a slight amount of slack in the cable when idling.



Periodically check all belts for wear. Replace any damaged or worn belts as needed.

3.7 RPM Adjustments



WARNING! Remove the blade before performing any engine service. Failure to do so may result in serious injury.



Check the RPM with a tachometer after the first 20 hours of operation and every 200 hours thereafter. High-end RPM should be 3650 (± 100) RPM and low-end RPM should be 1200 (not to exceed 1500).

Before checking the RPM, make sure belt and brake strap tension are correct (See Saw-mill Maintenance).

1. Start the engine to measure the low-end RPM.

Make sure that the throttle linkage is not affecting the engine RPM while the clutch/brake handle is disengaged. Make sure the cable is not bent or kinked. Refer to the engine manual to adjust the low-end RPM.

2. Engage the clutch handle to throttle the engine and measure the high-end RPM. Readjust the throttle linkage if necessary to increase or reduce the high-end engine speed.

See Figure 3-3. The engine should start to throttle as soon as you start moving the clutch handle down. If the engine dies instead, restart the engine and adjust the throttle linkage as far as possible without affecting low-end RPM. **NOTE:** A properly adjusted throttle will extend the cable spring 1/4" to 3/8" (6.4 - 9.5 mm) when running and have a slight amount of slack in the cable when idling.

SECTION 4 REPLACEMENT PARTS

4.1 How To Use The Parts List

- Use the table of contents or the index to locate the assembly that contains the part you need.
- Go to the appropriate section and locate the part in the illustration.
- Use the number pointing to the part to locate the correct part number and description in the table.
- Parts shown indented under another part are included with that part.
- Parts marked with a diamond (◆) are only available in the assembly listed above the part.

See the sample table below. Sample Part #A01111 includes part F02222-2 and subassembly A03333. Subassembly A03333 includes part S04444-4 and subassembly K05555. The diamond (◆) indicates that S04444-4 is not available except in subassembly A03333. Subassembly K05555 includes parts M06666 and F07777-77. The diamond (◆) indicates M06666 is not available except in subassembly K05555.

4.2 Sample Assembly				
REF	DESCRIPTION (◆ Indicates Parts Available In Assemblies Only)	PART #	QTY.	
	SAMPLE ASSEMBLY, COMPLETE (INCLUDES ALL INDENTED PARTS BELOW)	A01111	1	
1	Sample Part	F02222-22	1	
	Sample Subassembly (Includes All Indented Parts Below)	A03333	1	
2	Sample Part (◆ Indicates Part Is Only Available With A03333)	S04444-4	1	◆
	Sample Subassembly (Includes All Indented Parts Below)	K05555	1	
3	Sample Part (◆ Indicates Part Is Only Available With K05555)	M06666	2	◆
4	Sample Part	F07777-77	1	

To Order Parts:

- From Europe call our European Headquarters and Manufacturing Facility in Kolo, Poland at **+48-63-2626000**. From the continental U.S., call **1-800-448-7881** to order parts. Have your customer number, vehicle identification number, and part numbers ready when you call.
- From other international locations, contact the Wood-Mizer distributor in your area for parts.

4.3 Engine Assembly

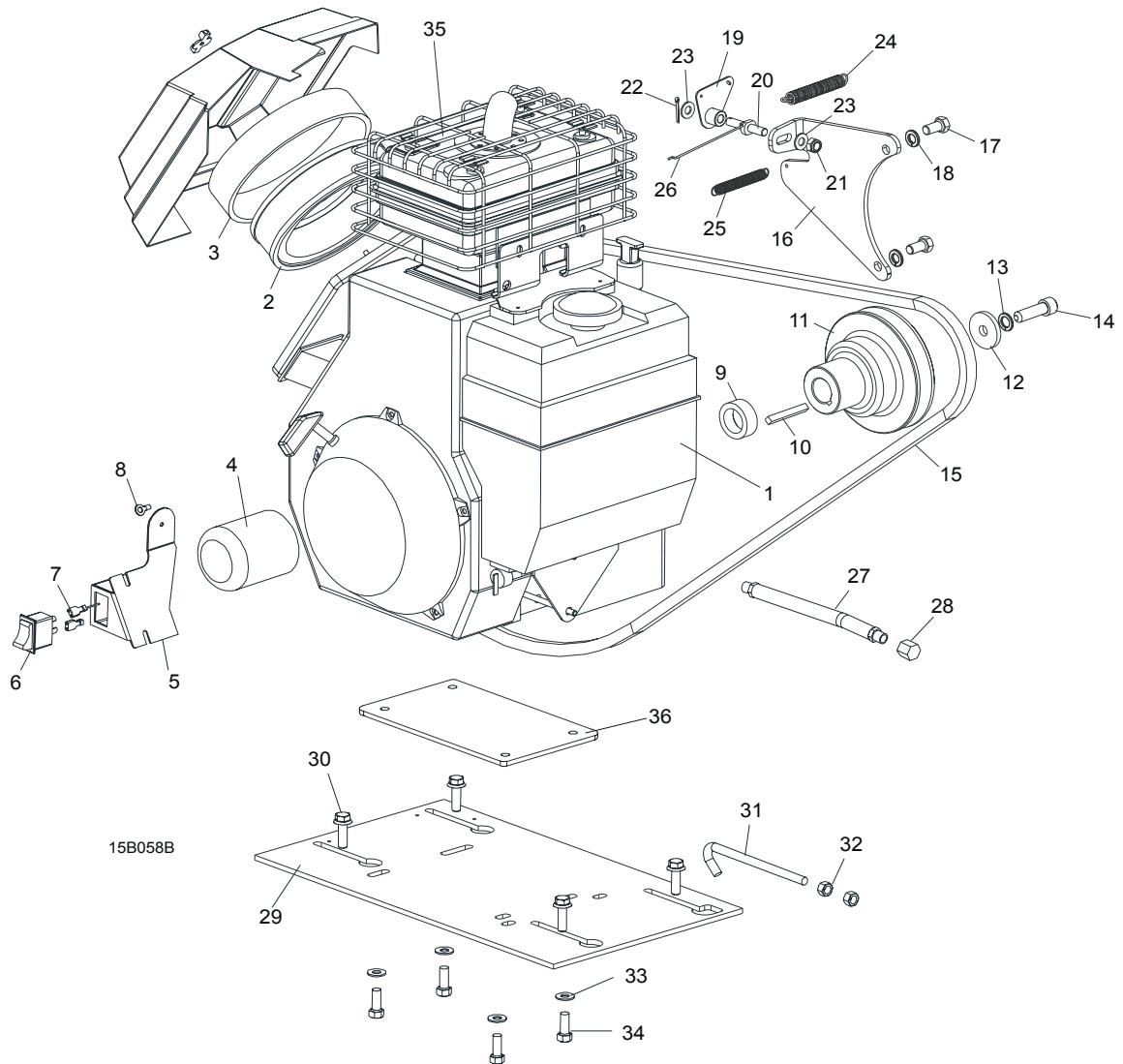

REF	DESCRIPTION (◆ Indicates Parts Available In Assemblies Only)	PART #	QTY.
ENGINE ASSY, 13 HP KOHLER			
1	Engine 15, HP Kohler #PA 44501	015440	1
2	Filter, Kohler Air #47-083-01	014718	1
3	Pre-Cleaner, Kohler Air #52-083-01	014719	1
4	Filter, Kohler Oil #52-050-02	014717	1
	Plug, Kohler Spark #12-132-02 (Champion #RC12YC)	P12757	1
	Filter, Kohler In-Line Fuel #25-050-02	014720	1
5	Bracket Weldment, Throttle Mount/Switch Mount	015441	1
6	Switch, Engine Stop/Run	015444	1

4 Replacement Parts

Engine Assembly

7	Terminal, 1/4" 14-16 Ga Quick Female FI	F05708-3	2	
8	Terminal, 1/4" 14-16 Ga Ring NI Loose	F05092-2	1	
9	Spacer, 1.016" x 1.5" x .56"	086551	1	
10	Key, 1/4" Square x 2" Long	S04124	1	
11	Pulley, G13 Engine	088057-1	1	
12	Washer, G13 Flat	088059-1	1	
13	Washer, 7/16" Split Lock	F05011-48	1	
14	Screw, 7/16-20 x 1 1/2 Socket Head	F05007-55	1	
15	Belt, BX83 1/2"	088110	1	
16	Plate, Throttle Mount	088009-1	1	
17	Bolt, 3/8-16 x 3/4" Hex Head Grade 2	F05007-27	2	
18	Washer, 3/8" Split Lock	F05011-4	2	
19	Bracket Weldment, Throttle Pivot	F81043-1	1	
20	Pivot, Throttle Bracket	088016	1	
21	Nut, M8-8 Hex Nylon Lock	F81032-2	1	
22	Pin, 5 x 20 Cotter	F81043-1	1	
23	Washer, 8.4 Flat	F81054-1	1	
24	Spring, 1/2" x 2 1/4" x .06" Extension	014817	1	
25	Spring, 3/8" x 3 Extension	014818	1	
26	Wire, Throttle	088019	1	
27	Hose, Oil Drain	P10082	1	
28	Cap, Oil Drain Hose	P04332	1	
29	Plate, G13 Engine Mount	091926-1	1	
30	Bolt, 3/8-16 x 1 1/4" Spring Washer Lock Hex Head	F05007-131	4	
31	Rod, Belt Tension Adjustment	014975	1	
32	Nut, 3/8-16 Hex	F05010-1	2	
33	Washer, 3/8" SAE Flat	F05011-3	4	
34	Bolt, 3/8-16 x 1" Hex Head	F05007-7	4	
35	Silencer assembly	088396-1		
36	Plate, G13/G15 Engine Mount	093129-1	1	

4.4 Throttle/Tensioner Assembly

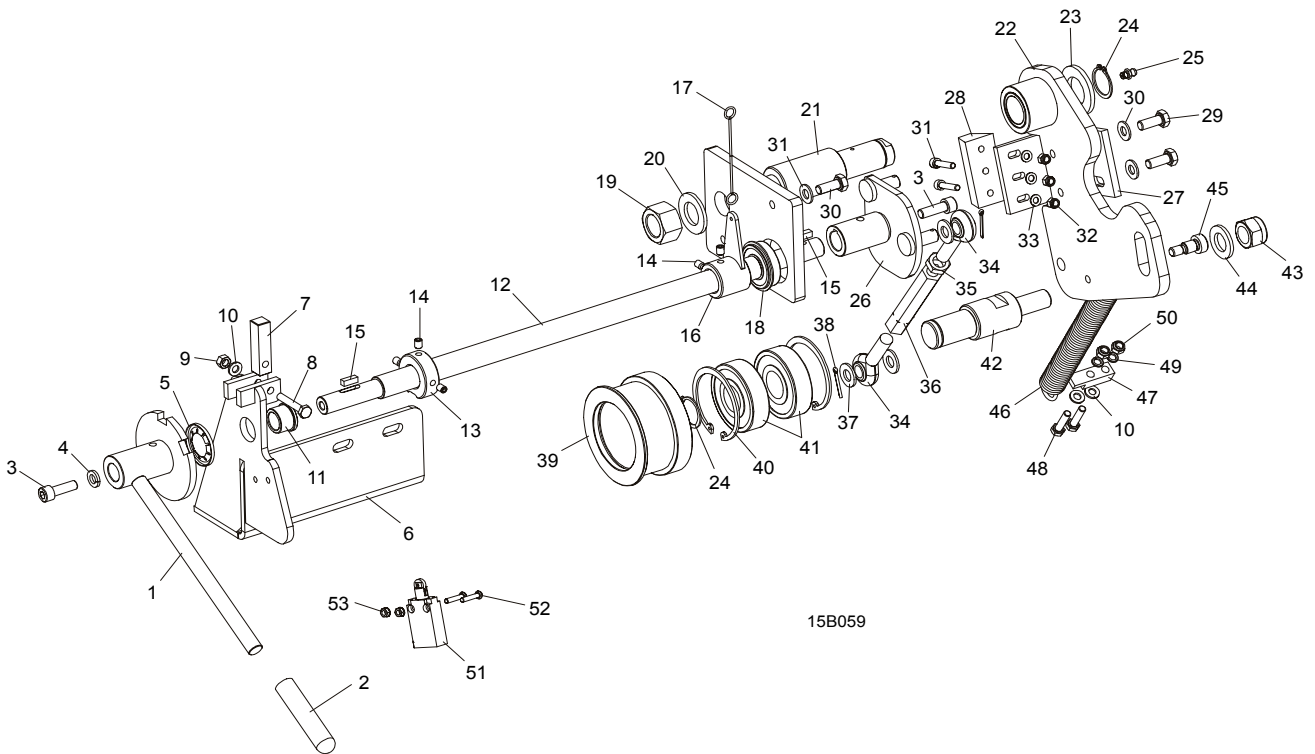

REF	DESCRIPTION (◆ Indicates Parts Available In Assemblies Only)	PART #	QTY.
	HANDLE ASSEMBLY, LT15 TENSIONER	087630	1
1	Handle, Throttle/Tensioner	087645-1	1
2	Grip, 1/2" I.D. x 3" Long Handle	014835	1
3	Bolt, M8 x 25 Socket Head	F81002-21	2
4	Washer 8.2 Split Lock	F81054-4	1
5	Ring, 7/8"	F04254-31	1
6	Bracket Weldment, Throttle/Tensioner Handle	087637-1	1
7	Pawl, Detent	086156	1
8	Bolt, M6 x 35-8.8 Hex Head	F81001-71	1
9	Nut, M6-8 Hex	F81031-1	1
10	Washer, 6.4 Flat	F81053-1	1
11	Bushing, Handle Throttle/Tensioner	086676	1
12	Rod, Throttle/Tensioner Handle	087640-1	1
13	Cam, Limit Switch	088021-1	1
14	Screw, Retaining	F81001-28	5
15	Key, A5 x 5 x 14	087365	1
16	Bracket, Throttle/Tensioner Handle Pivot	087988-1	1
17	Wire, Throttle	088020	1

4

Replacement Parts Throttle/Tensioner Assembly

18	Bearing, 6203-2RS w/Ring	086395	1	
19	Nut, M20-8 Hex	F81037-1	1	
20	Washer, 20.5	F81059-1	1	
21	Pin, Tensioner Handle	087643	1	
22	Bracket, Tensioner Main Mount	087675-1	1	
23	Washer, 25 Flat	F81059-5	1	
24	Ring, External Retaining	F81090-22	2	
25	Fitting, M6 Grease	086280	1	
26	Bracket, Tensioner Pivot	087638-1	1	
27	Bracket, Tensioner Brake Block	087669	1	
28	Block, Tensioner Brake	087648	1	
29	Bolt, M8 x 20-5.8 Hex Head	F81002-1	2	
30	Washer, 8.4 Flat	F81054-1	2	
31	Bolt, M5 x 25-5.8 Socket Head	F81000-7	3	
32	Nut, M5-8 Hex	F81030-2	3	
33	Washer, 5.3 Flat	F81052-1	3	
	Turnbuckle Assembly, Belt Tensioner			
34	Rod End, 7/16-20 Right Hand Thread	P11579	2	
35	Nut, 7/16-20 Hex Jam	F05010-38	1	
36	Turnbuckle, 3 3/4 Tensioner Handle	S12262	1	
37	Washer, 10.5 Flat	F81055-1	3	
38	Pin, 5 x 20 Cotter	F81043-1	2	
39	Wheel, Belt Tension	087671	1	
40	Ring, Internal Retaining	F81090-1	2	
41	Bearing, 6305 2RS NSK	P08066	2	
42	Pivot, Tension Wheel	087674	1	
43	Nut, M16-8 Hex	F81036-2	1	
44	Washer, 17 Flat	F81058-1	1	
45	Bolt, 10/M8 x 12-12.9	F81003-62	1	
46	Spring, Tensioner	P09136	1	
47	Bracket, Spring Mount	087989	1	
48	Bolt, M6 x 25-5.8 Socket Head	F81001-3	2	
49	Washer, 6.1 External Star	F81053-3	2	
50	Nut, M6-8 Hex	F81031-2	2	
51	Switch, XCMA 102 Limit	P21515-P	1	
52	Screw, #8-32 x 3/8 Self-Tap	F05015-8	2	
53	Nut, #8-32 Self Locking	F05010-41	2	