

G15 Engine

Safety, Operation, Maintenance & Parts Manual

LT25
LT25L

rev. C5.00
rev. C5.00



Safety is our #1 concern! Read and understand all safety information and instructions before operating, setting up or maintaining this machine.

Form #696

SECTION 1	SAFETY & GENERAL INFORMATION	1-1
1.1	Refueling	1-2
1.2	Engine Operation.....	1-2
SECTION 2	OPERATION	2-1
2.1	Starting The Engine	2-1
SECTION 3	MAINTENANCE	3-1
3.1	Air Filter & Pre-Cleaner	3-1
3.2	Air Cooling System	3-2
3.3	Fuel Filter	3-2
3.4	Miscellaneous Maintenance	3-2
3.5	RPM Adjustments	3-3
SECTION 4	REPLACEMENT PARTS	4-1
4.1	How To Use The Parts List	4-1
4.2	Sample Assembly	4-1
4.3	Engine Assembly.....	4-2
4.4	Engine Pulley Guards	4-4

SECTION 1 SAFETY & GENERAL INFORMATION



IMPORTANT! This manual is provided as a supplement to the equipment manufacturer's manuals. This manual takes into account the specific use of engines on the Wood-Mizer sawmill. Only safety, maintenance, and operating procedures that are not provided by the manufacturer are supplied in this manual. Refer to the manufacturer's manual before attempting to operate this equipment.



This symbol calls your attention to instructions concerning your personal safety. Be sure to observe and follow these instructions. This symbol accompanies a signal word. The word **DANGER** indicates an imminently hazardous situation which, if not avoided, will result in death or serious injury. **WARNING** suggests a potentially hazardous situation which, if not avoided, could result in death or serious injury. **CAUTION** refers to potentially hazardous situations which, if not avoided, may result in minor or moderate injury to persons or equipment. Read all safety instructions before operating this equipment and observe all safety warnings!

1 Safety & General Information

Refueling

1.1 Refueling



WARNING! Store gasoline away from sawdust and other flammable materials. Failure to do so may result in serious injury.

1.2 Engine Operation



DANGER! Always be sure the blade is disengaged and all persons are out of the path of the blade before starting the engine or motor. Failure to do so will result in serious injury.



WARNING! Do not for any reason adjust the engine drive belts or belt support bracket with the engine running. Doing so may result in serious injury.

WARNING! Remove the blade before performing any engine service. Failure to do so may result in serious injury.

WARNING! Always wear proper and necessary safety equipment when performing service functions. Proper safety equipment includes eye protection, breathing protection, hand protection and foot protection.



IMPORTANT! Always dispose of coolant, oil, fuel, oil filters and fuel filters in a responsible manner and in conformance with local, state and federal regulations.

SECTION 2 OPERATION

2.1 Starting The Engine

Engine Start



DANGER! Do not start the engine when the clutch/brake lever is in the engaged (down) position. Always be sure the blade is disengaged and all persons are away from the blade before starting the engine.

1. Turn the run/stop switch to the RUN position.

See Figure 2-1.

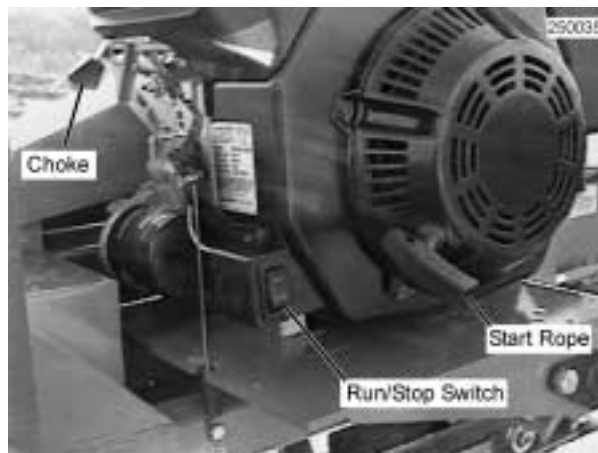

FIG. 2-1

2. Close the engine choke by moving the choke lever to the start position.



DANGER! Always be sure the blade is disengaged and all persons are out of the path of the blade before starting the engine or motor. Failure to do so will result in serious injury.

3. Pull the start rope slowly until you feel resistance, then pull the cord quickly to start the engine. Repeat with the choke opened slightly if necessary.
4. When the engine starts, slowly open the choke all the way by moving the choke lever to the off position.

For more information, see the engine manufacturer's operation manual.

2 **Operation** *Starting The Engine*

Engine Shutoff

1. Disengage the clutch handle to stop the blade if necessary.
2. Let the engine run for 15 seconds with no load, then push the run/stop switch to STOP.

SECTION 3 MAINTENANCE



IMPORTANT! This manual only provides information about additional procedures or procedures to be performed at different time intervals than found in the engine manufacturer's manuals. Refer to the *manufacturer's manual* for complete maintenance instructions.



WARNING! Remove the blade before performing any engine service. Failure to do so may result in serious injury.



This symbol identifies the interval (hours of operation) which each maintenance procedure should be performed. "AR" signifies maintenance procedures which should be performed as required.

3.1 Air Filter & Pre-Cleaner



WARNING! Always wear proper and necessary safety equipment when performing service functions. Proper safety equipment includes eye protection, breathing protection, hand protection and foot protection.



Service the pre-cleaner every four hours of operation. Service by gently shaking excess sawdust and debris from the foam piece.



Clean the air filter (air cleaner element) and pre-cleaner (element wrapper) every eight hours of operation. See the engine manual for further instructions.



Replace the air filter (cleaner) every 200 hours of operation.



Replace the pre-cleaner (element wrapper) every 2000 hours of operation.

3 Maintenance

Air Cooling System

3.2 Air Cooling System

50

Wash the engine or brush off sawdust and debris every 50 hours of operation. Clean the grass screen, cooling fins, and external surfaces. Remove any dust, dirt or oil. See engine manual for further instructions.

3.3 Fuel Filter

100

Replace the fuel filter every 100 hours of operation.

3.4 Miscellaneous Maintenance

100

Inspect the spark plugs every 100 hours of operation. Remove any deposits and adjust gap if necessary. See engine manual for further information.

3.5 RPM Adjustments



WARNING! Remove the blade before performing any engine service. Failure to do so may result in serious injury.



Check the RPM with a tachometer after the first 20 hours of operation and every 200 hours thereafter. High-end RPM should be 3650 (± 100) RPM and low-end RPM should be 1200 (not to exceed 1500).

Before checking the RPM, make sure belt and brake strap tension are correct (See Saw-mill Maintenance).

1. Start the engine to measure the low-end RPM.

Make sure that the throttle linkage is not affecting the engine RPM while the clutch/brake handle is disengaged. Make sure that the cable is not bent or kinked.

2. Refer to the engine manual to adjust the low-end RPM.
3. Engage the clutch handle to throttle the engine and measure the high-end RPM. Readjust the throttle cable if necessary to increase or reduce the high-end engine speed.

See Figure 3-1. The engine should start to throttle as soon as you start moving the clutch handle down. If the engine dies instead, restart the engine and adjust the throttle cable as far as possible without affecting low-end RPM. With the engine idling and the clutch disengaged, loosen the cable bolt and pull the throttle cable up to a point just below where it affects the low-end RPM. Retighten the cable bolt. **NOTE:** A properly adjusted throttle will extend the cable spring $1/4"$ to $3/8"$ (6.4 - 9.5 mm) when running and have a slight amount of slack in the cable when idling.

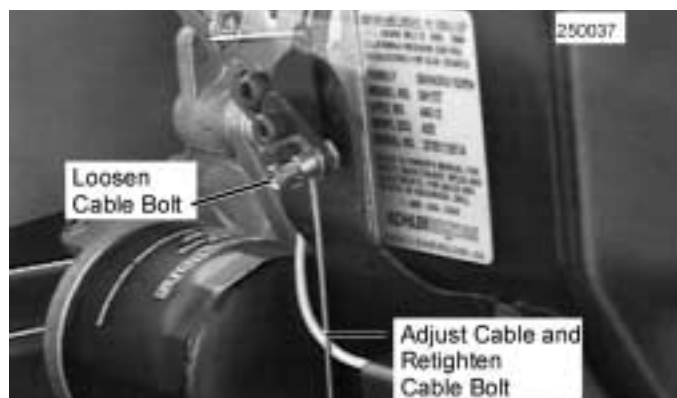

FIG. 3-1

SECTION 4 REPLACEMENT PARTS

4.1 How To Use The Parts List

- Use the table of contents or the index to locate the assembly that contains the part you need.
- Go to the appropriate section and locate the part in the illustration.
- Use the number pointing to the part to locate the correct part number and description in the table.
- Parts shown indented under another part are included with that part.
- Parts marked with a diamond (◆) are only available in the assembly listed above the part.

See the sample table below. Sample Part #A01111 includes part F02222-2 and subassembly A03333. Subassembly A03333 includes part S04444-4 and subassembly K05555. The diamond (◆) indicates that S04444-4 is not available except in subassembly A03333. Subassembly K05555 includes parts M06666 and F07777-77. The diamond (◆) indicates M06666 is not available except in subassembly K05555.

4.2 Sample Assembly				
REF	DESCRIPTION (◆ Indicates Parts Available In Assemblies Only)	PART #	QTY.	
	SAMPLE ASSEMBLY, COMPLETE (INCLUDES ALL INDENTED PARTS BELOW)	A01111	1	
1	Sample Part	F02222-22	1	
	Sample Subassembly (Includes All Indented Parts Below)	A03333	1	
2	Sample Part (◆ Indicates Part Is Only Available With A03333)	S04444-4	1	◆
	Sample Subassembly (Includes All Indented Parts Below)	K05555	1	
3	Sample Part (◆ Indicates Part Is Only Available With K05555)	M06666	2	◆
4	Sample Part	F07777-77	1	

To Order Parts:

- From Europe call our European Headquarters and Manufacturing Facility in Kolo, Poland at **+48-63-2610233** or **+48-3912-1319**. From the continental U.S., call **1-800-448-7881** to order parts. Have your customer number, vehicle identification number, and part numbers ready when you call.
- From other international locations, contact the Wood-Mizer distributor in your area for parts.

4 Replacement Parts

Engine Assembly

4.3 Engine Assembly

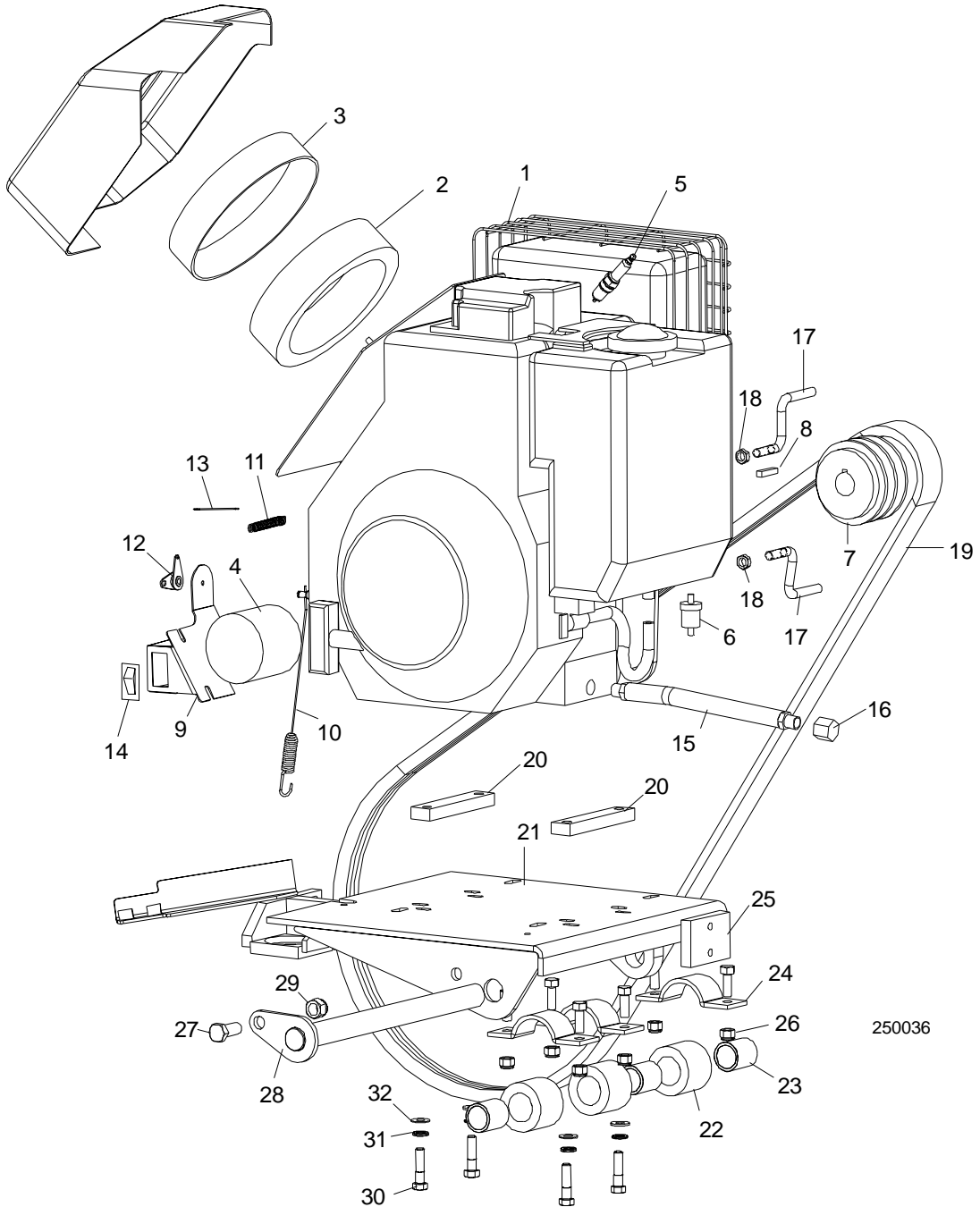

REF	DESCRIPTION (◆ Indicates Parts Available In Assemblies Only)	PART #	QTY.	
	ENGINE ASSEMBLY, 15HP KOHLER	GP15	1	
1	Engine, 15HP Kohler #PA44501	015440	1	◆

2	Filter, Kohler Air #47-083-01	014718	1	
3	Pre-Cleaner, Kohler Air #52-083-01	014719	1	
4	Filter, Kohler Oil #52-050-02	014717	1	
5	Plug, Kohler Spark #12-132-02 (Champion #RC12YC)	P12757	1	
6	Filter, Kohler In-Line Fuel #25-050-02	014720	1	
7	Pulley, 2BK36H Engine	015447	1	
8	Key, 1/4" Square x 2" Long	S04124	1	
9	Bracket Weldment, Throttle Mount/Switch Mount	015441	1	
10	Cable Assembly, G15 Throttle	015445	1	
11	Spring, G15 Throttle	015449	1	
12	Bracket Weldment, G15 Throttle Link Pivot	015435	1	
13	Bracket, G15 Throttle Link Wire	015446	1	
14	Switch, Engine Stop/Run	015444	1	
15	Hose, Oil Drain	P10082	1	
16	Cap, 3/8" NPT Pipe	P04332	1	
	SUPPORT KIT, ENGINE DRIVE BELT	K12790	1	
17	Bracket, Drive Belt Support	S12749	2	
18	Nut, 3/8-16 Jam	F05010-29	2	
19	BELT, 2BX72 DRIVE	P09555-2	1	
20	PLATE, G15 ENGINE SPACER	015345	2	
21	PLATE, MOTOR MOUNT LT25	014514	1	
	BUSHING ASSEMBLY, MOTOR MOUNT PIVOT	A04127	3	◆
22	Bushing, Rubber Motor Mount Pivot	P12164	1	
23	Spacer, Motor Mount Pivot	P05041	1	
24	PLATE, MOTOR MOUNT PIVOT BUSHING	014031	3	
25	BOLT, 3/8-16 X 1" HEX HEAD	F05007-7	6	
26	NUT, 3/8-16 HEX NYLON LOCK	F05010-10	6	
27	BOLT, M12 X 30-8.8 HEX HEAD GRADE 5	F81004-22	1	
28	PIN WELDMENT, ENGINE MOUNT PIVOT	014154	1	
29	NUT, M12-8 NYLON LOCK	F81034-2	1	
30	BOLT, 3/8-16 X 1 1/2" HEX HEAD	F05007-3	4	
31	WASHER, 10.2 SPLIT LOCK	F81055-2	4	
32	WASHER, 10.5 FLAT	F81055-1	4	

4 Replacement Parts

Engine Pulley Guards

4.4 Engine Pulley Guards

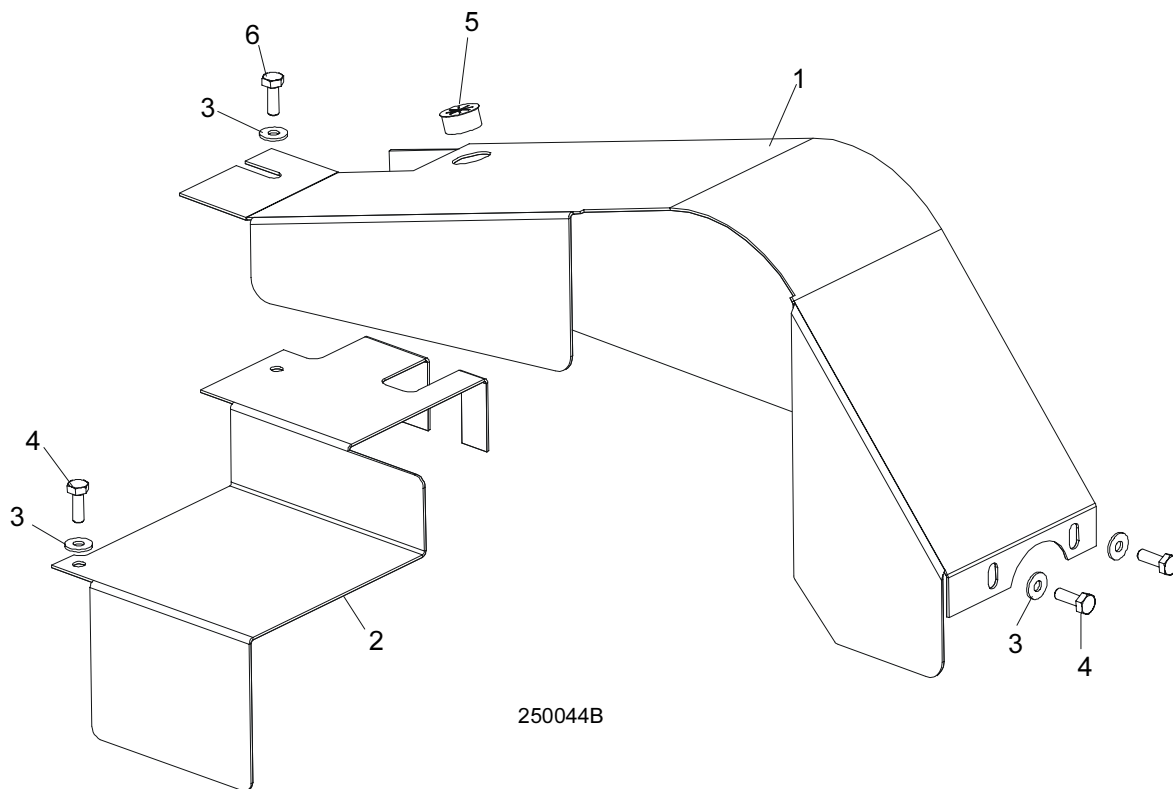

REF	DESCRIPTION (◆ Indicates Parts Available In Assemblies Only)	PART #	QTY.	
1	GUARD WELDMENT, G15 ENGINE PULLEY	015343	1	
2	GUARD, G15 SIDE ENGINE PULLEY	086402-1	1	
3	WASHER, 7.4 FLAT	F81056-11	4	
4	BOLT, M6X12-8.8-ZINC	F81001-7	3	
5	GROMMET, 5/8" WIRE	P04137	1	
6	BOLT, M6X20-8.8-ZINC	F81001-2	1	