

Wood-Mizer[®] Sawmill

Remote Operation

LT70LDH Remote

rev. A7.00

Operator's Manual



This manual is to replace the related appropriate information from the non-remote sawmill Operator's Manual

Form #678

Table of Contents

Section-Page

| | | |
|------------------|---|------------|
| SECTION 1 | REMOTE OPERATION | 1-1 |
| 1.1 | Preparing for Remote Operation | 1-2 |
| 1.2 | Remote Sawmill Operation | 1-4 |
| 1.3 | Preparing The Remote Option For Towing..... | 1-5 |
| 1.4 | Cold Weather Operation..... | 1-6 |
| 1.5 | Hydraulic Control Operation..... | 1-7 |
| SECTION 2 | MAINTENANCE & TROUBLESHOOTING | 2-1 |
| 2.1 | Control Pivot Lubrication..... | 2-1 |
| 2.2 | Clean The Cable Chain & Support Tray | 2-2 |
| 2.3 | Cable Chain Repair..... | 2-2 |
| 2.4 | Cable Chain And Support Tray Alignment..... | 2-3 |
| SECTION 3 | ELECTRICAL WIRING DIAGRAMS, D42 REMOTE | 3-1 |
| SECTION 4 | REMOTE OPERATION SYSTEM PARTS | 4-1 |
| 4.1 | Operators Box Pedestal | 4-1 |

SECTION 1 REMOTE OPERATION

The Remote Option provides remote operation for all sawmill functions from a single location at the front of the sawmill. The option includes all cables with traveling guide chain, a remote electrical power junction box, a front-mounted sawmill control box, and a remote clutch mechanism with switch to engage the blade from the remote location.

The Remote Option also includes Wood-Mizer's Simple Networks system which allows automatic, incremental up/down movement of the cutting head.

1 Remote Operation

Preparing for Remote Operation

1.1 Preparing for Remote Operation

Set up the sawmill as instructed in your sawmill operator's manual.



CAUTION! Moving the saw carriage before removing the cable chain support may cause damage to the chain. Also, moving the saw carriage when the chain is frozen can damage the chain. [See Section 1.4](#) for recommended chain deicing procedure.

See Figure 1-1. Before moving the saw carriage, remove the cable chain support bracket.

1. Disengage the rubber strap holding the cable chain to the support bracket.
2. Loosen the handles and remove the support bracket from the sawmill track rail.
3. Place the support bracket on the storage bracket located on the sawmill frame between the first and second bed rails. Tighten the handles to secure the support bracket to the storage bracket and secure the rubber strap in the bracket hole.

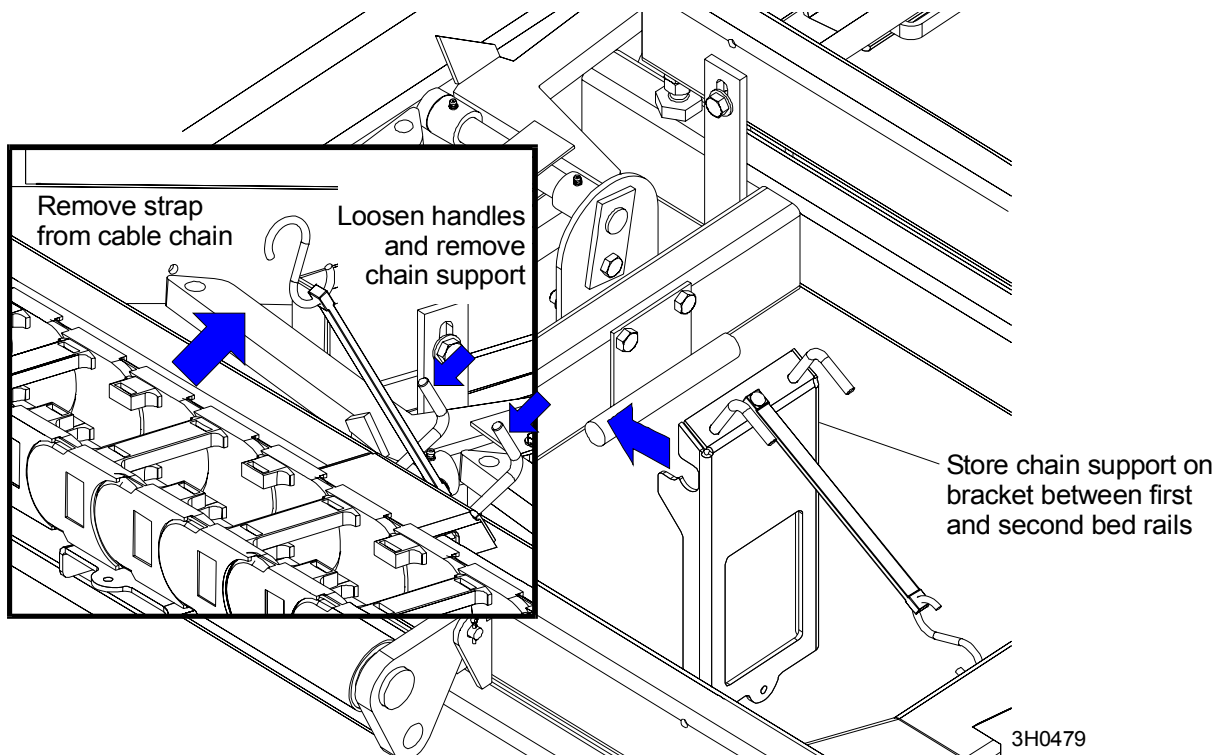

FIG. 1-1

Before operating the controls on the control box, you will need to pivot the control from its travel position to the operating position.

See Figure 1-2.



FIG. 1-2

1. Turn the control pivot locking handle counterclockwise.
2. Pivot the control assembly 180 degrees so the controls face the front of the sawmill.
3. Turn the control pivot locking handle clockwise to lock the control in place. The lock is designed to loosely hold the control in the operating position. The control can still be pivoted as needed during the sawing operation. The lock will hold the control firmly in the traveling position during towing.

1 Remote Operation

Remote Sawmill Operation

1.2 Remote Sawmill Operation



See Figure 1-3. All sawmill controls operate exactly as described in your sawmill operator's manual except the clutch/brake. Instead of pulling a handle to engage the blade, push the toggle switch on the control panel up. Hold the switch up until the clutch motor stops completely. The remote clutch mechanism will disengage the brake, rev the motor to full throttle, and start the blade spinning.



DANGER! Keep all persons out of the path of moving equipment and logs when operating sawmill or loading and turning logs. Failure to do so will result in serious injury.

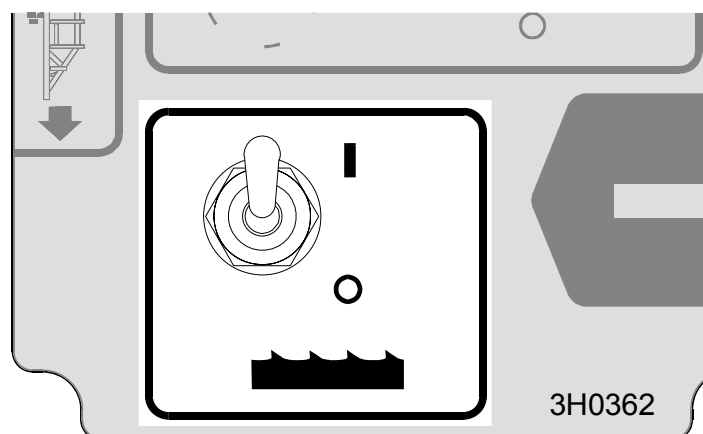

FIG. 1-3

To stop the blade and engage the blade brake, push the toggle switch down. This will also return the engine to idle.

NOTE: Be sure the toggle switch stays in the up or down position. The boot on the switch may spring the switch back to neutral. You may need to hold the switch in position until the remote clutch motor completes its cycle.

1.3 Preparing The Remote Option For Towing



1. After placing the saw head in its traveling position, engage the remote clutch switch to engage the drive belts. This will keep the engine from bouncing while towing the sawmill.
2. Turn the locking handle counterclockwise and pivot the control box to its traveling position. Turn the locking knob clockwise to secure the control box in position.
3. Place the chain support bracket under the cable chain, located between the first and second bed rails.

See Figure 1-4.

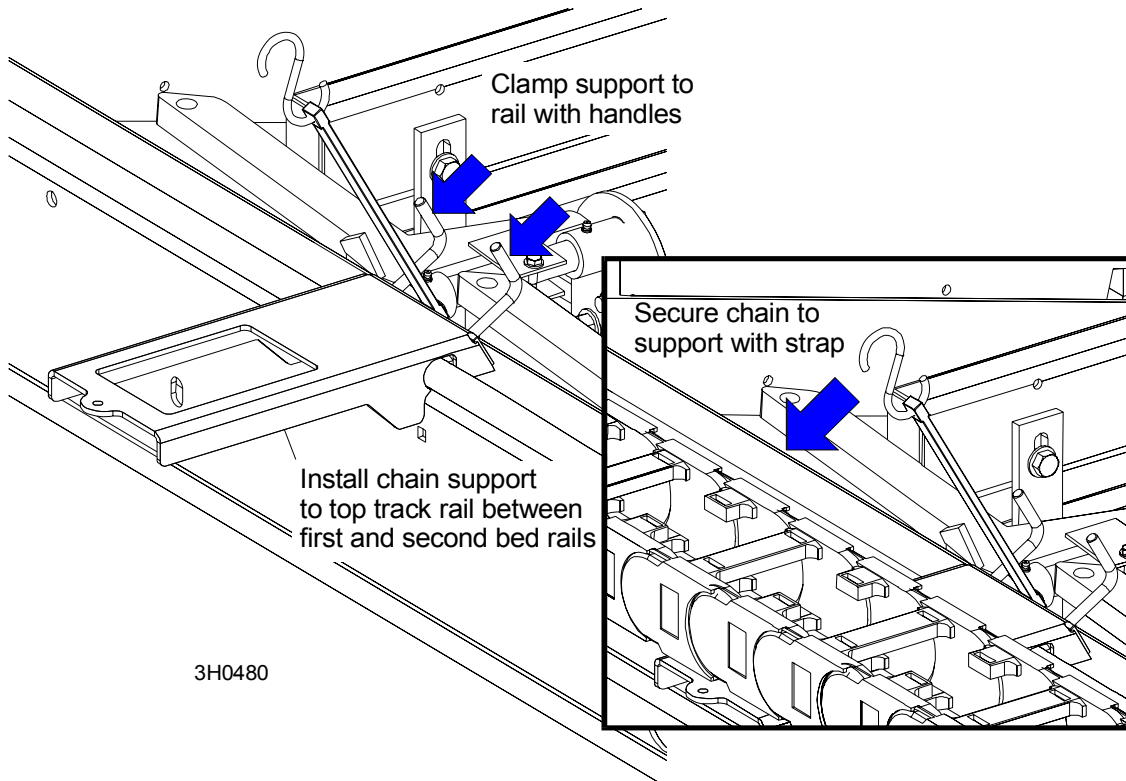

FIG. 1-4

4. Tighten the support handles and secure the chain to the support with the rubber strap.

1.4 Cold Weather Operation

If the sawmill is operated or stored in freezing conditions, the cable chain may freeze. Before moving the saw carriage, check to see if the chain is frozen:

1. Remove the chain support bracket ([See Section 1.1](#)).
2. Pull the chain up at a few locations to determine if it moves freely. If you detect the chain is frozen, proceed to the recommended deicing procedure below.
3. If the chain seems to move freely by hand, use the power feed to slowly move the saw carriage toward the rear of the mill. Since the saw carriage returns only at full speed, moving the saw carriage forward will allow you to slowly engage the cable chain to be sure it is not frozen. If you detect the chain is frozen, proceed to the recommended deicing procedure below.

Recommended Cable Chain deicing Procedure

To de-ice the chain, apply a salt solution (preferably calcium chloride and water) to the entire length of the chain. Allow the solution to sit until the chain can move freely. The strength of the solution and time required to free the chain will depend on how cold the weather is and how much ice has accumulated in the chain.

Before storing the sawmill after using the salt solution, be sure to rinse the salt from any metal portions of the sawmill frame to prevent corrosion. Refer to the recommended cold-weather storage procedure below to prevent the chain from freezing.

Recommended Cable Chain Ice Prevention Procedure

Before storing the sawmill in freezing temperatures, apply a 50/50 solution of environmentally safe antifreeze (Sierra) and water to the cable chain. A garden sprayer can be used to apply the solution.

1.5 Hydraulic Control Operation

The hydraulic control levers become operational when the contacts at the bottom of the carriage touch the power strip on the frame tube. The hydraulic control levers will only work when the cutting head is close enough to the front end of the mill to touch the power strip.

See Figure 1-5. Hydraulic units have eleven control levers to load, clamp, turn and level logs.



FIG. 1-5

Use the hydraulic control levers to get the mill ready to load a log.

 **DANGER!** Keep all persons out of the path of moving equipment and logs when operating sawmill or loading and turning logs. Failure to do so will result in serious injury.

 **CAUTION!** Always make sure the engine is running before operating the hydraulic controls. Operating the controls without the engine running will result in power drainage from the battery.

1

Remote Operation

Hydraulic Control Operation

1. Move the clamp out and down so it will not get in the way of logs being loaded onto the bed.



Lower the clamp in/out lever to move the clamp out toward the loading side of the sawmill.



Lower the clamp up/down lever to lower the clamp below bed level.

2. Raise the log loader lever to extend the legs of the log loader out as far as they will go.



3. The chain securing the log loading arm to the bed frame will be tight. Manually push the log loader arm until there is slack in the chain.

4. Unchain the loading arm from the bed frame.

5. Lower the turner lever to completely lower the turner arm. Notice that after the turner arm is all the way down, the side support braces will begin to lower. Release the turner lever after the turner arm is lowered, but before the side supports begin to lower. This stops the log being loaded from damaging the turner and/or falling off the side of the sawmill.



6. When raising the turner lever, the side supports rise first. After reaching a fully vertical position, the turner arm will engage and start to rise.

7. Manually lower the log loader so it rests on the ground.



CAUTION! Be careful when manually lowering the log loader. Do not drop the loader onto the ground or perform any action which might break the velocity fuse valves on the loader cylinders. These valves control hydraulic flow and are necessary to prevent the loading arm from collapsing during use.

8. Lower the loader lever to lower the loading arm as far as it will go. Logs must be rolled onto the loading arms one at a time.



9. The front, middle and rear toe boards should be below bed level. Once a tapered log has been loaded, the front or rear end of the log may be lifted to parallel the heart of the log to the path of the blade.



The front toe board is raised by lifting the front toe board lever up. The middle toe board is raised by lifting the middle toe board lever up. The rear toe board is raised by lifting the rear toe board lever up. Once a flat has been made and the log is ready to be turned, push the appropriate toe board lever down to lower either toe board until it falls below the

level of the bed.

SECTION 2 MAINTENANCE & TROUBLESHOOTING

2.1 Control Pivot Lubrication

 Lubricate the control pivot as necessary to allow the control box to pivot freely. Apply a NLGI No. 2 grade lithium grease to the grease fitting supplied above the pivot locking handle.

See Figure 2-1.

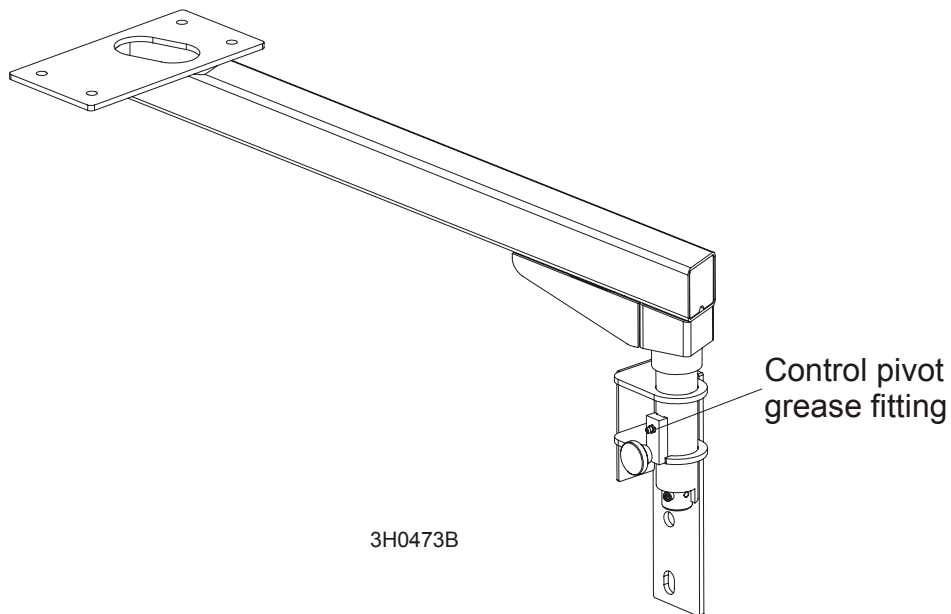

FIG. 2-1

2.2 Clean The Cable Chain & Support Tray

As you operate the sawmill, be aware of any pieces of debris that may fall on the cable chain and/or support tray. Stop the sawmill and immediately remove any pieces of wood, bark or anything else that may divert the path of the chain or cause it to jam.

Clean the cable chain and support track of sawdust buildup every eight hours of operation. Blow or brush the sawdust from the track and tray and remove any accumulated sawdust that is high enough to contact the chain/tray.

2.3 Cable Chain Repair

If a component of the cable chain breaks or is missing, replace the component.



CAUTION! Do not operate the remote sawmill if the cable chain is damaged or components of the chain are missing. The chain components are interlocking and continued operation will cause more damage to the chain.

See **Figure 2-2**. To disassemble the chain use a screwdriver to pry the connecting links apart. After removing the connecting links, the side plates can be disassembled by pulling them apart at an angle.

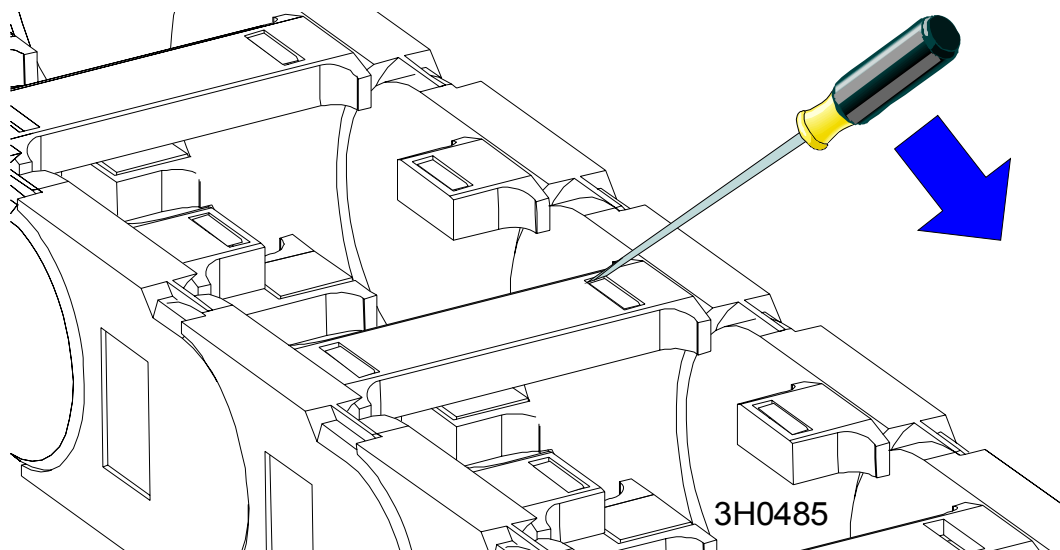

FIG. 2-2

2.4 Cable Chain And Support Tray Alignment

During each sawmill setup, check the alignment of the cable chain and the support tray:

1. The chain should travel in a straight line. Traveling at an angle will cause the chain to prematurely wear and break. Check the alignment of the chain by measuring from the sawmill frame tube to the center of the chain at the top and bottom. The measurements should be the same ($\pm 1/8"$).

See Figure 2-3.

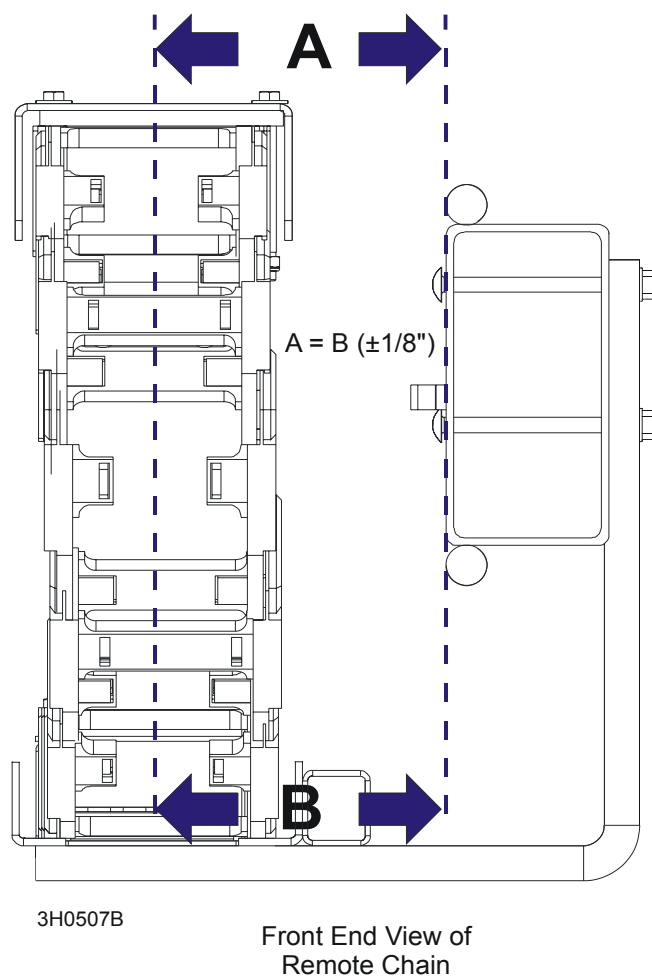

FIG. 2-3

Loosen the mounting bolts at the top or bottom of the chain to adjust the distance from the sawmill frame tube.

2. The chain support tray must be level to prevent premature wear of the chain. Use a square to check the angle of the tray to the sawmill frame. Check at several locations along the length of the tray.

See Figure 2-4.

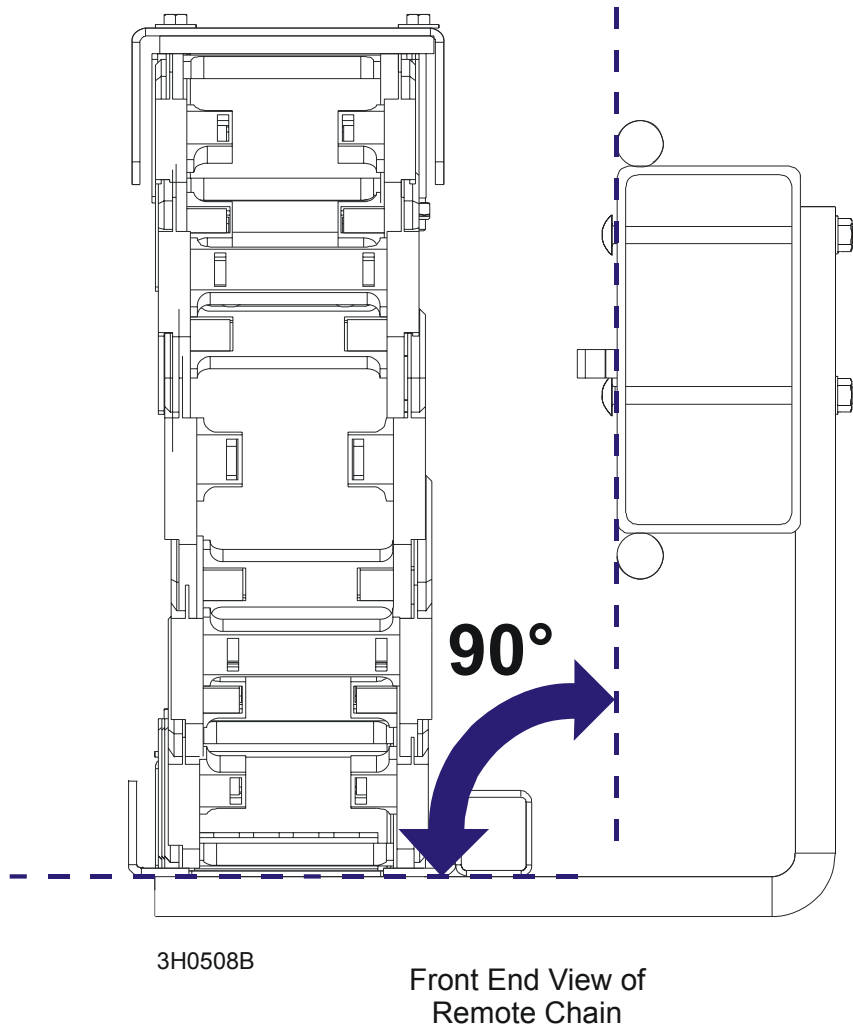

FIG. 2-4

Bend the tray up or down as necessary to square it to the sawmill frame.

SECTION 3 ELECTRICAL WIRING DIAGRAMS, D42 REMOTE



IMPORTANT! When using a sawmill with the rewired control panel it is very important not to switch between saw head forward/backward movement until the saw head stops. Failure to do so may result in serious sawmill damage.



WARNING! When using the variable reverse speed wiring it is recommended that the operator should stop the head, turn the potentiometer to zero, engage reverse and then increase speed. Failure to do this may result in damage to the circuit. There is a protection in the circuit and if this is activated it will not allow the head to start the return movement until the potentiometer is set to zero.

| Component List | | | | |
|-------------------------|----------------|-------------|---------------------|--|
| Item | Mfg. Part No. | Mfg. | Wood-Mizer Part No. | Description |
| A1 | 023730 | Wood-Mizer | 023730 | Alternator, 140 Amp |
| B1 | GHS0360UD602R0 | MTS Systems | 052130 | Transducer, 36" Start/Stop Magnetostrictive Sensor G-Series |
| CB1 | CH30407-30 | Cole-Hersee | E20431 | Circuit Breaker, 30A Manual Reset |
| CB2 | CH30407-15 | Cole-Hersee | E20430 | Breaker, 15 Amp Manual Reset, Accessory |
| CB3 | CH30407-15 | Cole-Hersee | E20430 | Breaker, 15 Amp Manual Reset, Ignition |
| CB4 | CH30407-15 | Cole-Hersee | E20430 | Breaker, 15 Amp Manual Reset, Start |
| CB5 | CH30407-15 | Cole-Hersee | E20430 | Breaker, 15 Amp Manual Reset, Blade Guide |
| CB6 | CH30407-15 | Cole-Hersee | E20430 | Breaker, 15 Amp Manual Reset, Not Used |
| CB7, CB8 | 015527 | Mech. Prod. | 015527 | Breaker, 70 Amp Manual Reset Panel Mount (Feed, Up/Dn) |
| CB10 | 024453 | Wood-Mizer | 024453 | Breaker Assembly, Water Temp Max Circuit |
| D1 - D5 | 015426 | Wood-Mizer | 015426 | Diode Assembly, Solenoid Coil Chassis |
| D6 | 024629 | Wood-Mizer | 024629 | Actuator, LA121000-20401210 Linear |
| E1 | 201554 | MTS Systems | 024876 | Magnet, Sensor |
| F1 | RL-225 | Gould | P11550 | Fuse Link, 225 Amp, 250 Volt For Hydraulic + 12 Volt Circuit |
| F2 | RL-150 | Gould | 023361 | Fuse Link, 150A 250V For Main + 12 Volt Starter, Alternator |
| F4 | N/A | N/A | 024597 | Fuse Link, 50 Amp Kubota Glow Plug |
| F9 | ATO-2 | Little Fuse | 024150-2 | Fuse, 2 Amp ATO Blade Light Gray |
| FB1 | 050998 | Wood-Mizer | 050998 | Filter Board, Accuset RF |
| FB2 | 050997 | Wood-Mizer | 050997 | Filter Board, Accuset Drive Amplifier |
| G1 | 24M-7 | Deka | P12315 | Battery, 12 Volt |
| GP1-GP4 | 16851-65510 | Kubota | 028562 | Glow Plug |
| H1 | 093166 | ENM Corp. | 093166 | Hour Meter, 12 Volt |
| L7 | 17208-60012 | Wood-Mizer | 046951 | Solenoid, Fuel Stop |
| SOL1, SOL8, SOL9, SOL10 | 015470 | Stancor | 015470 | Solenoid Kit, 200A 12V SPST |
| M1 | PR4R0009Q | Owosso | 014359 | Motor, 12 Volt Power Feed |
| M2 | PR-4P07Q | Owosso | A07974 | Motor, 12 Volt Up/Down |
| M3 | P09698-1 | Klauber | A10365 | Motor, 12 Volt Blade Guide Arm 53:1 Gear |
| M4, M5 | 8111 | Monarch | P09955 | Motor, 12 Volt Hydraulic Pump |
| M6 | 091309 | Linak | 091309 | Motor, 12 Volt Auto Clutch |
| P4 | 052165 | Wood-Mizer | 052165 | Cable Assembly, Accuset Transducer Adaptor |
| PCB1 | 089694 | Wood-Mizer | 089694 | Board, LED Circuit (Diesel) |
| PCB2 | 051667 | Wood-Mizer | 051667 | Circuit Board, Control Box Power Feed |
| PF1 | 051260 | Wood-Mizer | 051260 | Filter Assembly, Accuset Power |
| PF2 | 051260 | Wood-Mizer | 051260 | Filter Assembly, Accuset Power |
| PNL1 | 050949 | Wood-Mizer | 050949 | Panel Assembly, Remote Accuset Control |
| PNL2 | 035572 | Wood-Mizer | 035572 | Panel Assembly, Remote Accuset Power |
| PNL3 | 024768 | Wood-Mizer | 024768 | Panel Assembly, Remote Accuset Mosfet |
| R1 | 092277 | Wehrle | 092277 | Relay, Glow Plug |
| RS1 | 024260 | Wood-Mizer | 024260 | Wire Assembly, Accessory Solenoid Voltage Drop |

3 Electrical Information

| Component List | | | | |
|-----------------------|----------------------|-------------|----------------------------|--|
| Item | Mfg. Part No. | Mfg. | Wood-Mizer Part No. | Description |
| RS2 | 024451 | Wood-Mizer | 024451 | Wire Assembly, Hydraulic Solenoid Voltage Drop |
| S1 | 2601-AF2-S11 | Square D | E20439 | Drum Switch, Power Feed Fwd/Reverse Motor |
| S2 | 2601-AF2-S12 | Square D | E20440 | Drum Switch, Up/Down Motor |
| S3, S5 | 34-591Q | Pollak | 024200 | Toggle Switch, Blade Guide In/Out Motor |
| S4 | 024198 | Wood-Mizer | 024198 | Switch, Hydraulic Pump Levers |
| S6, S7 | 024627 | Wood-Mizer | 024627 | Sensor Assembly, Proximity Magnetic |
| S8 | 15841-39010 | Kubota | 028547 | Switch, Oil Pressure Sensor |
| S9 | TM9A230RQCG | Kubota | 028510 | Switch, Water Temp Sensor |
| VR1 | E20519 | Wood-Mizer | E20519 | Potentiometer, Variable Resistance Power Feed |

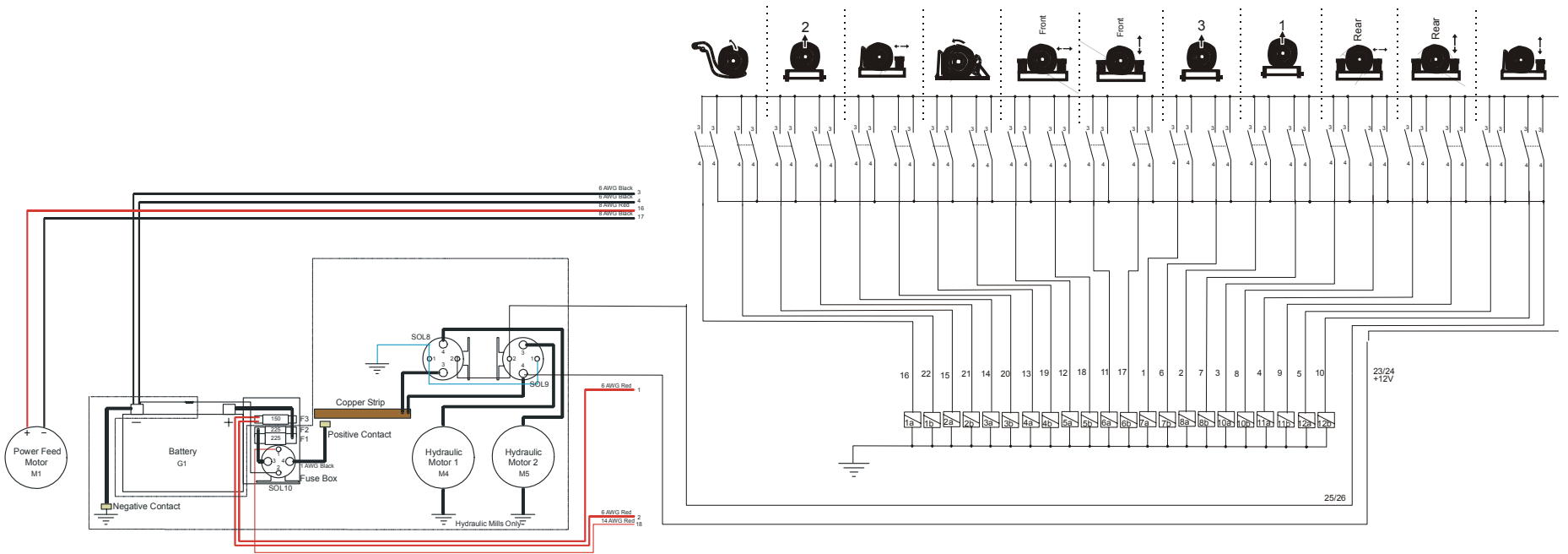

FIG. 3-1 . D42 HYDRAULIC DIAGRAM

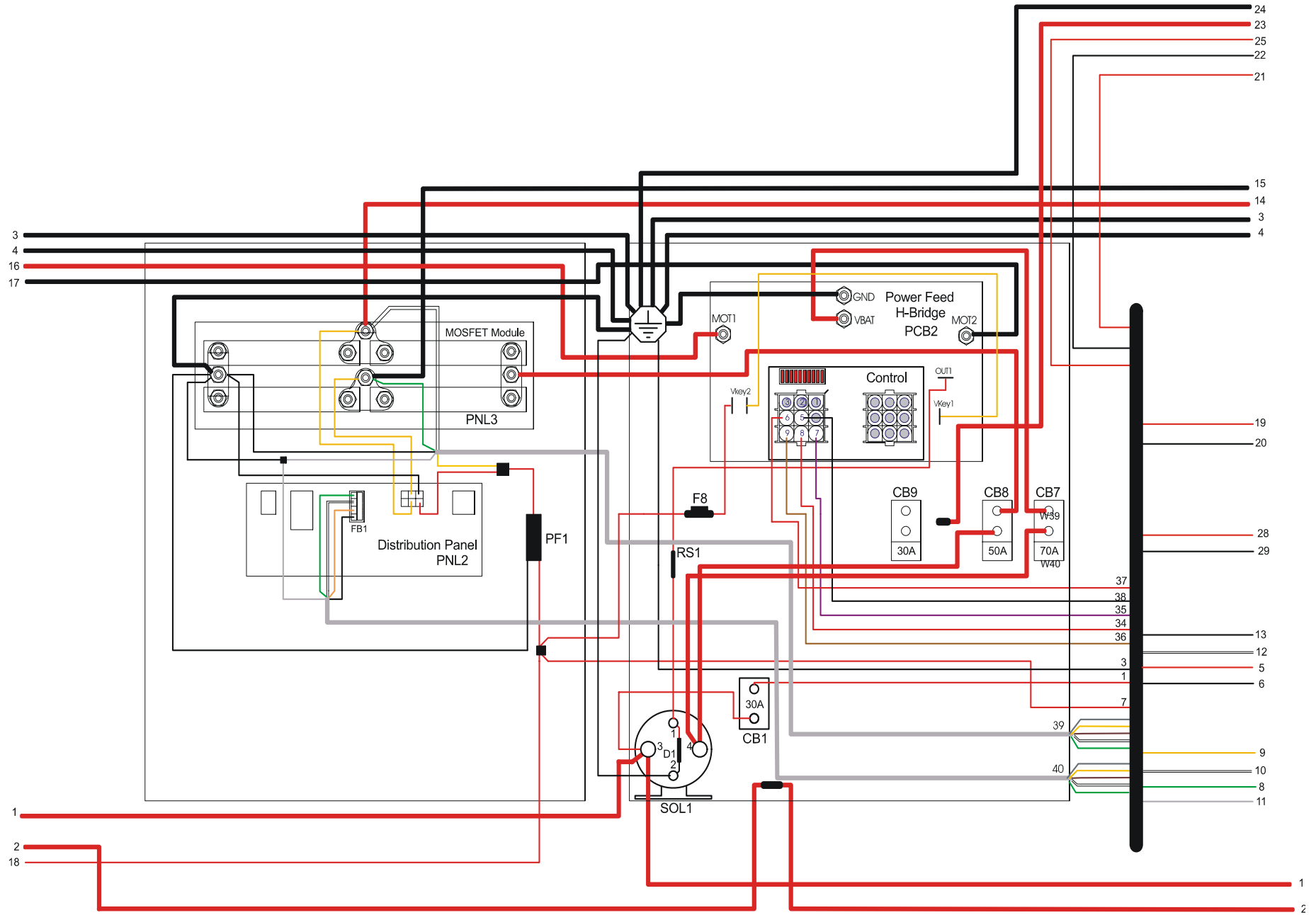

FIG. 3-2 ELECTRIC BOX DIAGRAM

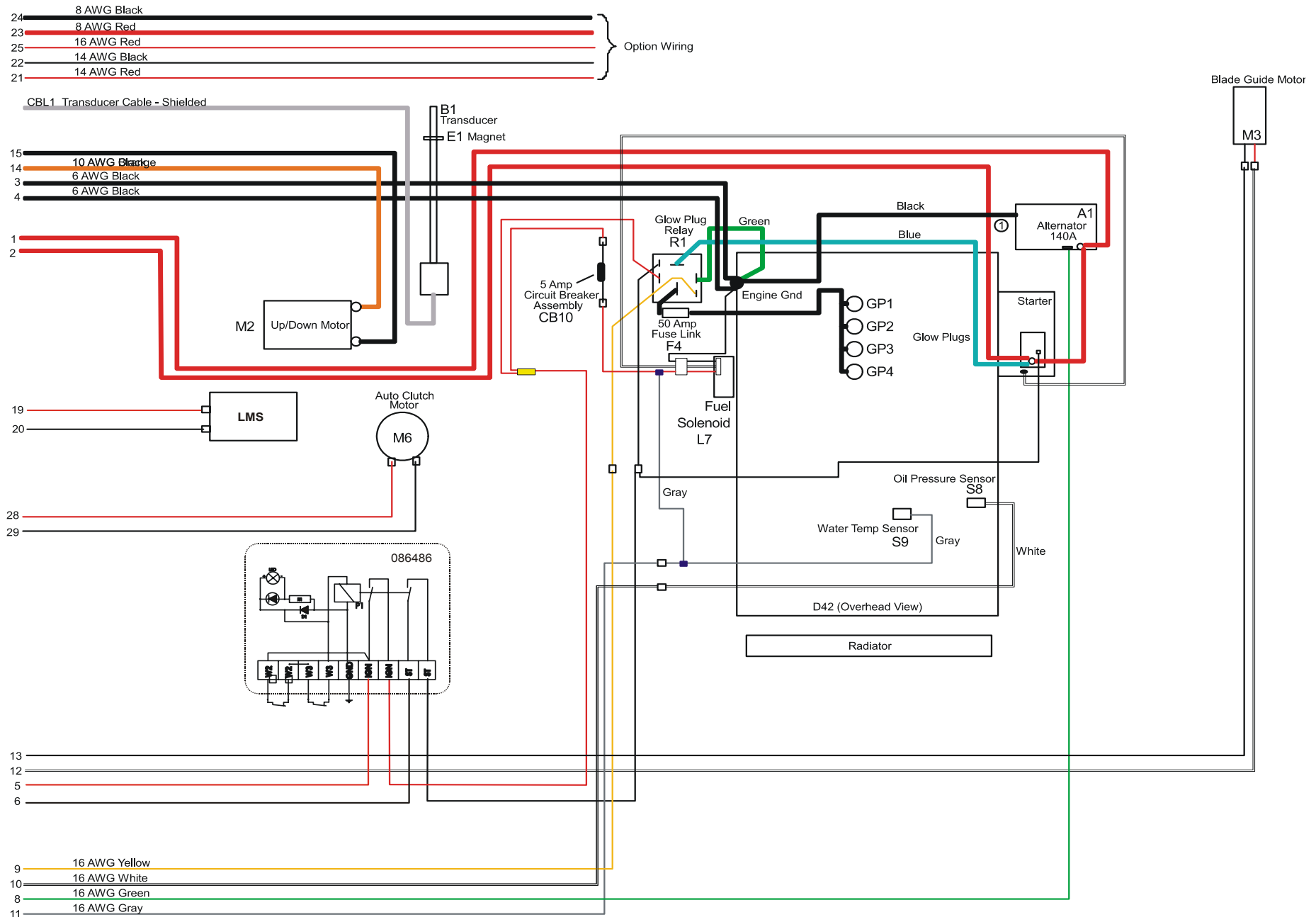
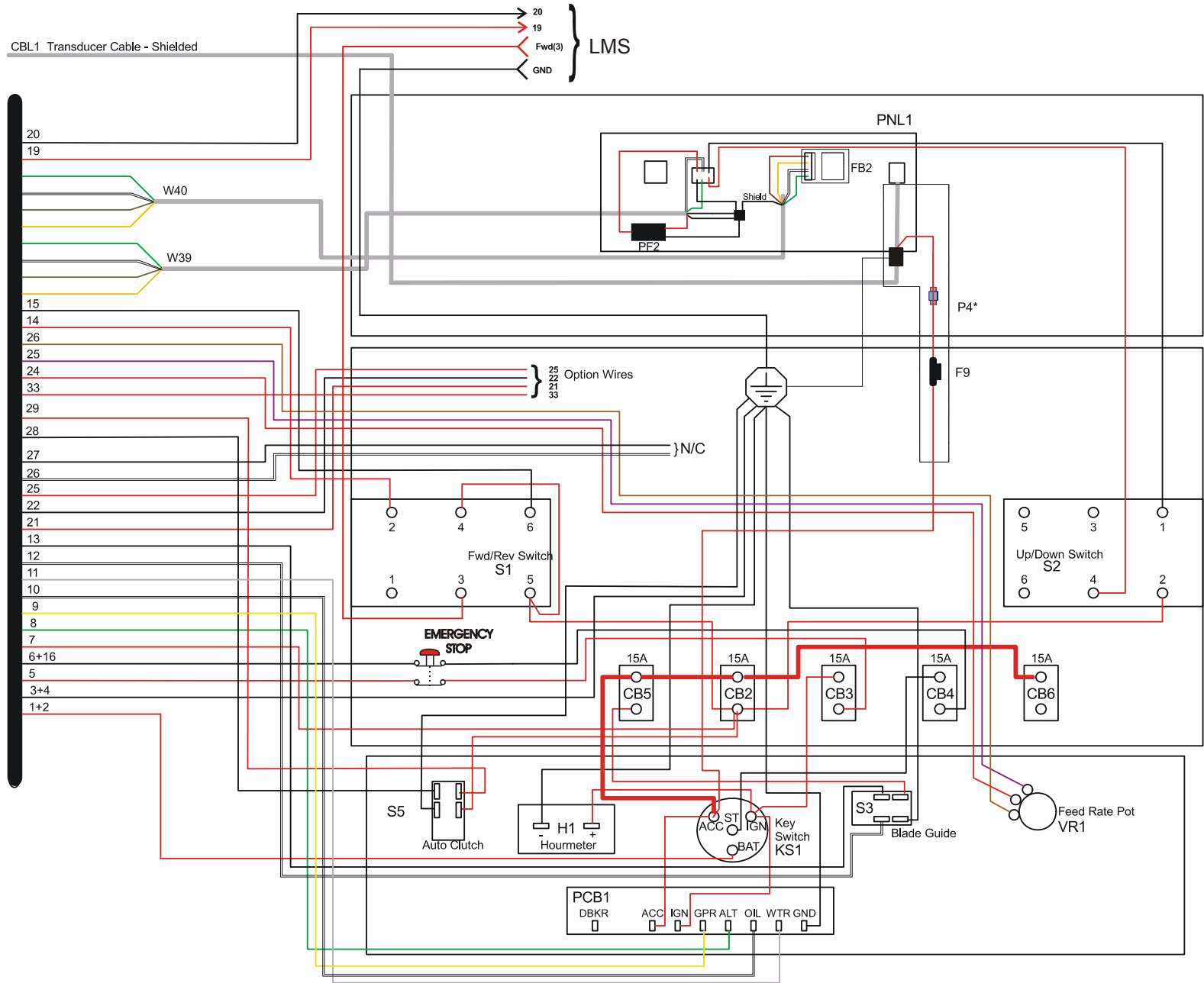
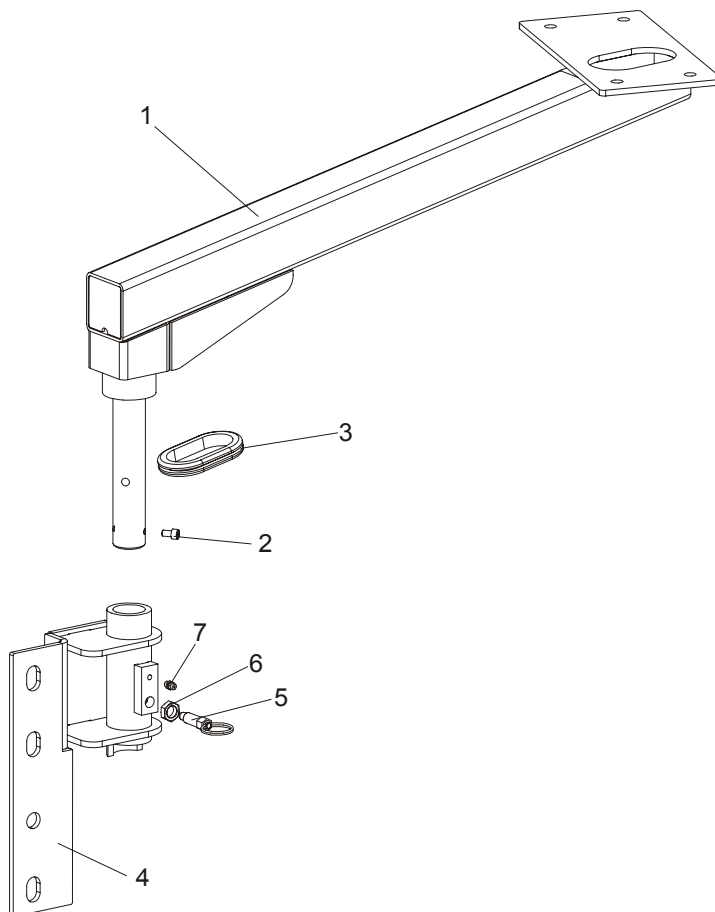

FIG. 4-4 D42 WIRING DIAGRAM (LT70 REMOTE SAWMILLS).



SECTION 4 REMOTE OPERATION SYSTEM PARTS

4.1 Operators Box Pedestal



| REF | DESCRIPTION (◆ Indicates Parts Available In Assemblies Only) | PART # | QTY. |
|-----|--|-----------|------|
| | PEDESTAL WELDMENT, REMOTE, COMPLETE | 089315 | 1 |
| 1 | Pedestal Weldment Remote, ptd | 088858-1 | 1 |
| 2 | Screw, M6x10 -8.8- Fe/Zn5 Hex Socket Head Cap | F81001-12 | 1 |
| 3 | Grommet, Rubber | 087065 | 1 |
| 4 | Pedestal Bracket | 096892-1 | 1 |
| 5 | Pin, GN 717-8-AK | 096954 | 1 |
| 6 | Nut, M12-04-A Fe/Zn5 | F81034-6 | 1 |
| 7 | Fitting, M6 Grease | 086280 | 1 |