

# **E25 Motor**

## **Safety, Operation, Maintenance & Parts Manual**

---

<b>LT30 Super</b>	<b>rev. C7.00</b>
<b>LT40 Super</b>	<b>rev. C7.00</b>
<b>LT30HD Super</b>	<b>rev. C7.00</b>
<b>LT40HD Super</b>	<b>rev. C7.00</b>

---



**Safety is our #1 concern!** Read and understand all safety information and instructions before operating, setting up or maintaining this machine.

*Form #668*

## **CAUTION!**

The electric motor which operates the saw blade is capable of developing horsepower up to two or more times the horsepower listed on the motor nameplate. While the mill design allows for using this increased horsepower intermittently while sawing, it is possible in very aggressive cutting to overload the motor. Aggressive sawing for long periods may cause excessive heat buildup. An internal thermal protection device has been installed to ensure no damage to the motor can result from this overloading. This device shuts off the motor when its internal operating temperature becomes too hot. The motor will operate normally again after it cools (approximately 20 to 30 minutes).

# Table of Contents

# Section-Page

<b>SECTION 1</b>	<b>SAFETY &amp; GENERAL INFORMATION</b>	<b>1-1</b>
1.1	Motor Operation .....	1-1
1.2	Battery Handling .....	1-2
1.3	Electrical Operation.....	1-3
<b>SECTION 2</b>	<b>OPERATION</b>	<b>2-1</b>
2.1	Starting The Motor .....	2-1
<b>SECTION 3</b>	<b>MAINTENANCE</b>	<b>3-1</b>
3.1	Battery .....	3-1
3.2	Alternator Belt .....	3-2
<b>SECTION 4</b>	<b>REPLACEMENT PARTS</b>	<b>4-1</b>
4.1	How To Use The Parts List .....	4-1
4.2	Sample Assembly .....	4-1
4.3	Motor Starter Box Assembly.....	4-2
4.4	Motor Assembly .....	4-3
4.5	Motor Mount Assembly .....	4-4
4.6	Drive and Alternator Assembly.....	4-5
4.7	Motor Pulley Guards .....	4-7
<b>SECTION 5</b>	<b>ELECTRICAL INFORMATION</b>	<b>5-1</b>
5.1	Electrical Symbol Diagram, E25 .....	5-1
5.2	Electrical Components, E25 .....	5-4
5.3	Battery Specifications, E25 .....	5-5
5.4	Electrical Wiring Diagram, E25 .....	5-7



## SECTION 1 SAFETY & GENERAL INFORMATION



**IMPORTANT!** This manual is provided as a supplement to the equipment manufacturer's manuals. This manual takes into account the specific use of engines on the Wood-Mizer sawmill. Only safety, maintenance, and operating procedures that are not provided by the manufacturer are supplied in this manual. Refer to the manufacturer's manual before attempting to operate this equipment.



This symbol calls your attention to instructions concerning your personal safety. Be sure to observe and follow these instructions. This symbol accompanies a signal word. The word **DANGER** indicates an imminently hazardous situation which, if not avoided, will result in death or serious injury. **WARNING** suggests a potentially hazardous situation which, if not avoided, could result in death or serious injury. **CAUTION** refers to potentially hazardous situations which, if not avoided, may result in minor or moderate injury to persons or equipment. Read all safety instructions before operating this equipment and observe all safety warnings!

### 1.1 Motor Operation



**DANGER!** Always be sure the blade is disengaged and all persons are out of the path of the blade before starting the engine or motor. Failure to do so will result in serious injury.



**WARNING!** Do not for any reason adjust the motor drive belts or belt support bracket with the motor running. Doing so may result in serious injury.

**WARNING!** Remove the blade before performing any motor service. Failure to do so may result in serious injury.



**WARNING!** Be sure the power feed switch is in the neutral position before turning the key switch to the on (#1) or accessory (#3) position. This prevents accidental carriage movement, which may cause serious injury or death.

# 1 Safety & General Information

## Battery Handling

---

### 1.2 Battery Handling



**DANGER!** Batteries expel explosive gases. Keep sparks, flames, burning cigarettes, or other ignition sources away at all times. Always wear safety goggles and a face shield when working near batteries. Failure to do so will cause serious injury.<sup>1</sup>



**WARNING!** Charge the battery in a well ventilated area. Do not attempt to charge a frozen battery.

**WARNING!** Use extreme care to avoid spilling or splashing electrolyte (which is dilute sulfuric acid) as it can destroy clothing and burn the skin. If electrolyte is spilled or splashed on clothing or the body, it should be neutralized immediately and then rinsed with clean water. A solution of baking soda, or household ammonia, and water may be used as a neutralizer.

Electrolyte splashed into the eyes is extremely dangerous. If this should happen, force the eye open and flood it with cool, clean water for approximately fifteen minutes. A doctor should be called immediately when the accident occurs and “on-the-spot” medical attention given if possible. If a doctor cannot come to the scene of the accident immediately, follow his instructions concerning actions to take. Do not add eye drops or other medication unless advised to do so by the doctor. Do not place a battery or acid within the reach of children. If acid (electrolyte) is taken internally drink large quantities of water or milk. Follow with milk of magnesia, beaten egg or vegetable oil. Call a physician immediately.

If electrolyte is spilled or splashed on any surface of the machine, it should be neutralized and rinsed with clean water.<sup>1</sup>

---

1. Battery Council International, copyright 1987

### 1.3 Electrical Operation



**DANGER!** Make sure all electrical installation, service and/or maintenance work is performed by a qualified electrician and is in accordance with applicable electrical codes.

**DANGER!** Hazardous voltage inside the disconnect box, starter box, and at the electric motor can cause shock, burns, or death. Disconnect and lock out power supply before servicing! Keep all electrical component covers closed and securely fastened during mill operation.

**CAUTION!** The sawmill's electrical starter should only be switched on after the phase converter is up to speed. Do not attempt to operate the sawmill without the phase converter operating properly. Damage to the equipment may result.





## SECTION 2 OPERATION

### 2.1 Starting The Motor

#### Engine Control Lights

See **Figure 2-1**. The following indicator lights are located on the sawmill control panel.



*Alternator Charge Indicator:* Lights if the alternator is not charging the battery.



*Key Switch Indicator:* Lights up when the key is in either the on (#1) or accessory (#3) position.

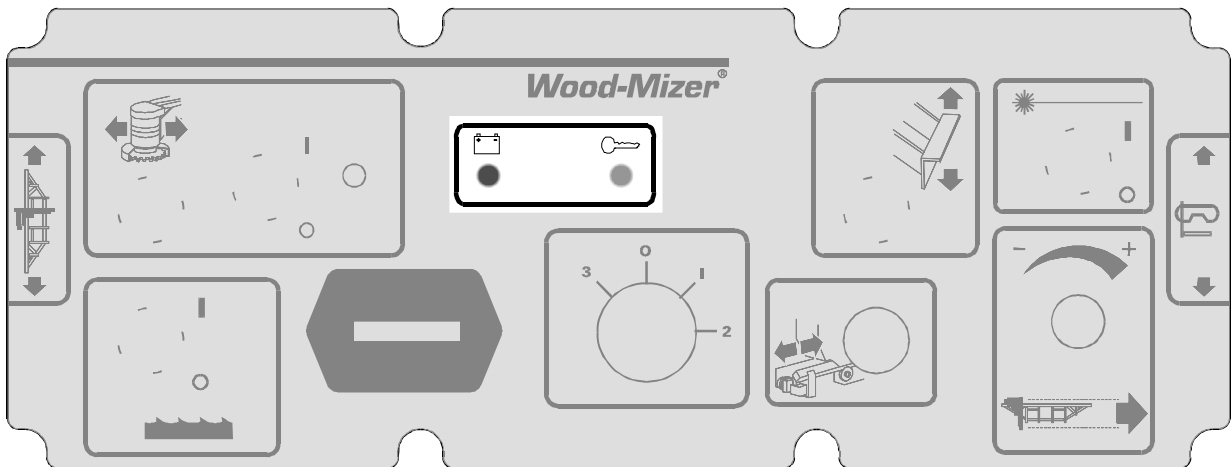

**FIG. 2-1**

**Motor Start**

**DANGER!** Always be sure the blade is disengaged and all persons are out of the path of the blade before starting the engine or motor. Failure to do so will result in serious injury.



**WARNING!** Be sure the power feed switch is in the neutral position before turning the key switch to the on (#1) or accessory (#3) position. This prevents accidental carriage movement, which may cause serious injury or death.

Turn the key switch to the start (#2) position and release.

**Motor Shutoff**

Turn the key switch to the off (#0) position.

---

## SECTION 3 MAINTENANCE



**This symbol** identifies the interval (hours of operation) which each maintenance procedure should be performed. "AR" signifies maintenance procedures which should be performed as required.

### 3.1 Battery



Check the battery electrolyte level every 50 hours of operation. See manufacturer's manual for instructions.



**DANGER!** Batteries expel explosive gases. Keep sparks, flames, burning cigarettes, or other ignition sources away at all times. Always wear safety goggles and a face shield when working near batteries. Failure to do so will cause serious injury.

# 3 Maintenance

## Alternator Belt

### 3.2 Alternator Belt

The belt tension should be checked after the first 100 hours of operation, when the battery is not charging properly or when the alternator belt is squealing. Adjustment is provided to allow the operator the ability to return the belt to factory-set tension (3/8" [9.5mm] deflection with 6 lbs. of deflection force). If the battery continues to not charge properly or the belt continues to squeal after the initial belt adjustment, replace the belt.

1. Turn the key switch to OFF (0) and remove the key.
2. Loosen the top pivot cover screw and move the cover to access the sight hole in the alternator mounting bracket.

See Figure 3-1.

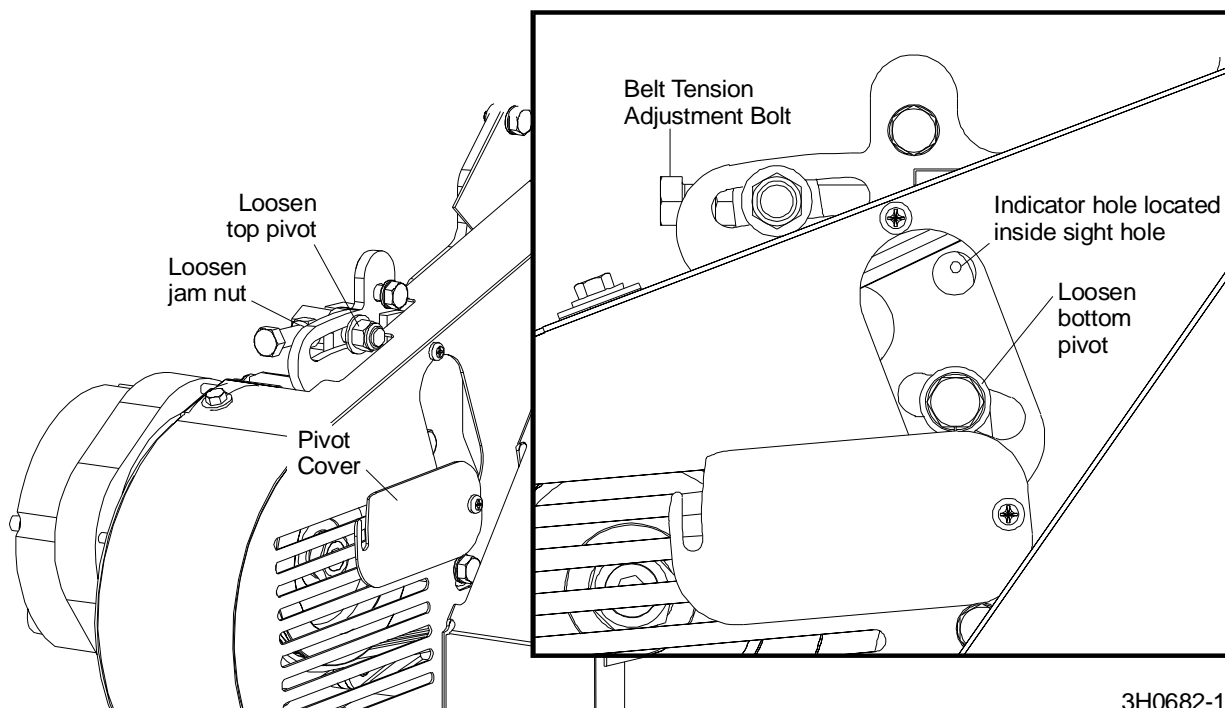

3H0682-1

**FIG. 3-1**

3. When the small indicator hole is approximately centered in the large sight hole, the belt is properly tensioned. To adjust the alternator belt, loosen the top and bottom pivot bolts and the adjustment bolt jam nut.
4. Turn the belt tension adjustment bolt clockwise to tighten the belt, counterclockwise to loosen the belt. As the belt is tightened, the indicator hole will move to the left inside the sight hole. Adjust the bolt until the indicator hole is approximately centered in the sight hole.

hole. Do not adjust the bolt so much that the indicator hole passes the edge of the sight hole.

**CAUTION!** Do not overtighten the alternator belt. Damage to the alternator will occur.

5. After the alternator belt has been tensioned, tighten the adjustment bolt jam nut. Tighten the upper and lower pivot bolts. Return the pivot cover to its original location and tighten the cover screw.



## SECTION 4 REPLACEMENT PARTS

### 4.1 How To Use The Parts List

- Use the table of contents or the index to locate the assembly that contains the part you need.
- Go to the appropriate section and locate the part in the illustration.
- Use the number pointing to the part to locate the correct part number and description in the table.
- Parts shown indented under another part are included with that part.
- Parts marked with a diamond (◆) are only available in the assembly listed above the part.

See the sample table below. Sample Part #A01111 includes part F02222-2 and subassembly A03333. Subassembly A03333 includes part S04444-4 and subassembly K05555. The diamond (◆) indicates that S04444-4 is not available except in subassembly A03333. Subassembly K05555 includes parts M06666 and F07777-77. The diamond (◆) indicates M06666 is not available except in subassembly K05555.

<b>4.2 Sample Assembly</b>				
REF	DESCRIPTION (◆ Indicates Parts Available In Assemblies Only)	PART #	QTY.	
	<b>SAMPLE ASSEMBLY, COMPLETE (INCLUDES ALL INDENTED PARTS BELOW)</b>	A01111	1	
1	Sample Part	F02222-22	1	
	Sample Subassembly (Includes All Indented Parts Below)	A03333	1	
2	Sample Part (◆ Indicates Part Is Only Available With A03333)	S04444-4	1	◆
	Sample Subassembly (Includes All Indented Parts Below)	K05555	1	
3	Sample Part (◆ Indicates Part Is Only Available With K05555)	M06666	2	◆
4	Sample Part	F07777-77	1	

#### To Order Parts:

- From Europe call our European Headquarters and Manufacturing Facility in Kolo, Poland at **+48-63-2610233** or **+48-3912-1319**. From the continental U.S., call **1-800-448-7881** to order parts. Have your customer number, vehicle identification number, and part numbers ready when you call.
- From other international locations, contact the Wood-Mizer distributor in your area for parts.

# 4 Replacement Parts

## Motor Starter Box Assembly

### 4.3 Motor Starter Box Assembly

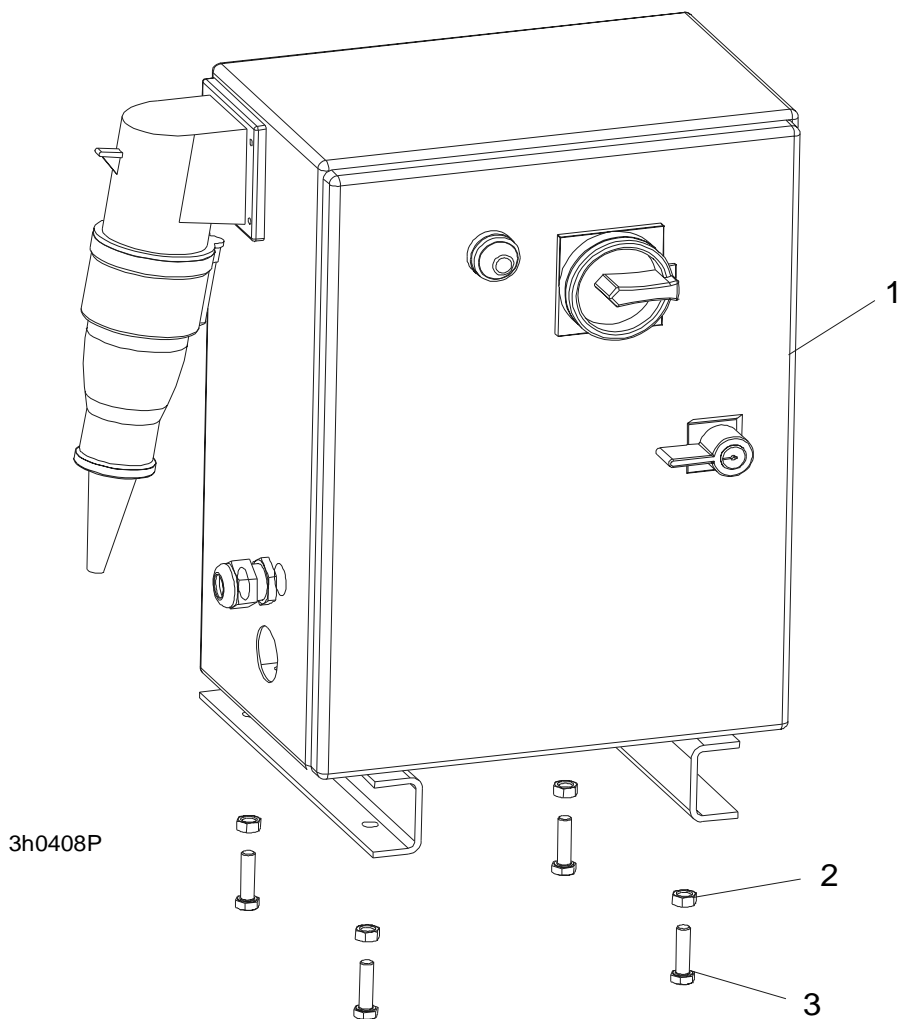

REF	DESCRIPTION (◆ Indicates Parts Available In Assemblies Only)	PART #	QTY.	
1	STARTER ASSEMBLY, 25HP 3-PHASE 50/60HZ 3450 RPM ELECTRIC MOTOR	A11890	1	
2	NUT, M8-8-B HEX	F81032-1	4	
3	BOLT, M8 x 30 8.8-B HEX HEAD TAP	F81002-7	4	



### 4.4 Motor Assembly

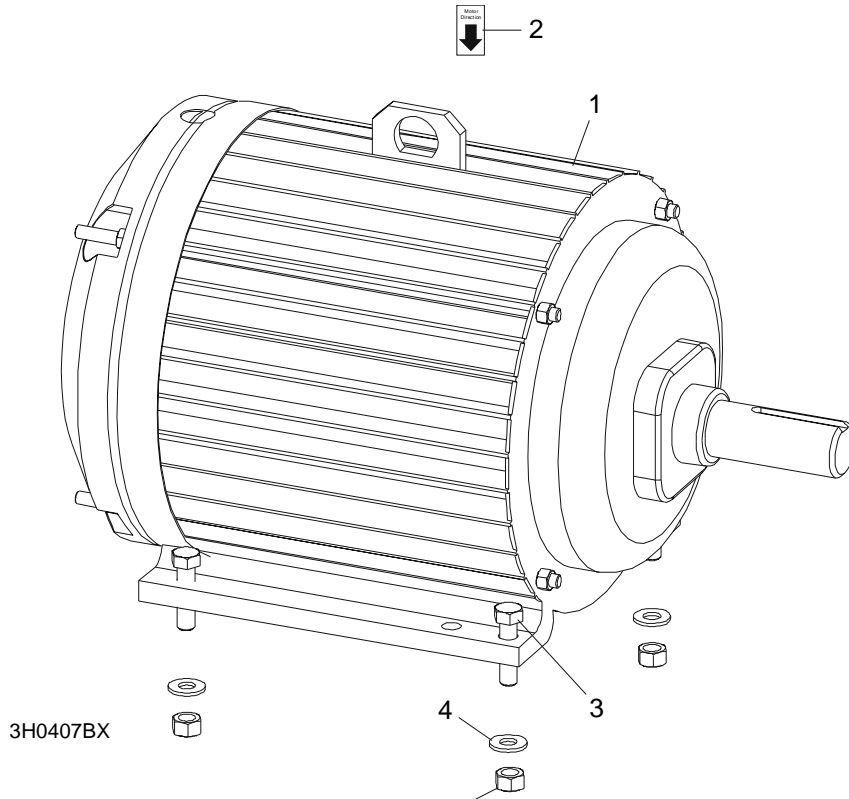

REF	DESCRIPTION (◆ Indicates Parts Available In Assemblies Only)	PART #	QTY.	
1	<b>MOTOR ASSEMBLY, 25HP ELECTRIC PREMIUM EFFICIENCY CUSTOM</b>	085519 <sup>1</sup>	1	
	<b>MOTOR ASSEMBLY, 25HP ELECTRIC (ENGLAND ONLY)</b>	085519-1	1	
	<b>MOTOR ASSEMBLY, 25HP 230 VOLT ELECTRIC (NORWAY ONLY)</b>	085519-2	1	
2	Decal, Motor Direction	S20097	1	
3	<b>BOLT, M12 X 45 - 8.8 HEX HEAD GRADE 5</b>	F81004-32	4	
4	<b>WASHER, M12-8-B FLAT</b>	F81034-1	4	
5	<b>NUT, M12-8 HEX LOCK</b>	F81034-2	4	

<sup>1</sup> NOTE: The electric motors supplied on Wood-Mizer sawmills carry a rating assigned by the motor manufacturer for the continuous duty operation of the motor, potentially, 24 hours per day, day after day. This rating is useful in sizing motors for use in applications like blowers for heating and ventilation that are never cycled off except for system maintenance.

The Wood-Mizer sawmill is a classic example of an intermittent duty application due to the variations in wood species, cutting widths, blade conditions, cycle times, etc. For this reason, the electric motors used by Wood-Mizer have been custom designed and are capable of developing a minimum of twice their continuous duty ratings under the heavy sawing conditions that occur in the operating of our sawmills. The field windings of these electric motors have internal thermal protection so that overloading of the motor is prevented. Functionally, our electric motors exceed the performance of internal combustion engines with twice the horsepower ratings in this specific application.

## 4 Replacement Parts

### Motor Mount Assembly

#### 4.5 Motor Mount Assembly

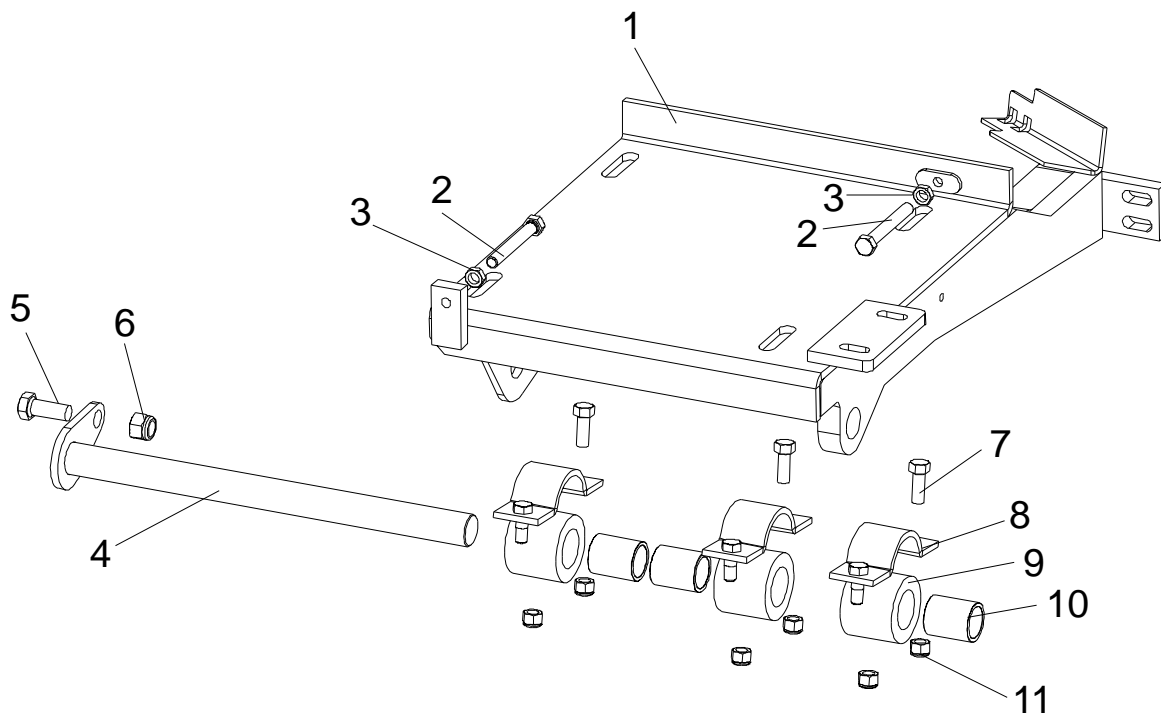

3H0406

REF	DESCRIPTION (◆ Indicates Parts Available In Assemblies Only)	PART #	QTY.
1	MOUNT WELDMENT, ELECTRIC MOTOR	086801-1	1
2	BOLT, 3/8-16 X 3" HEX HEAD FULL THREAD	F05007-1	2
3	NUT, 3/8-16 HEX JAM	F05010-29	2
4	PIN WELDMENT, ENGINE MOUNT PIVOT	014154	1
5	BOLT, M12 X 30-8.8 HEX HEAD GRADE 5	F81004-22	1
6	NUT, M12-8 NYLON LOCK	F81034-2	1
7	BOLT, 3/8-16 X 1" HEX HEAD	F05007-7	3
8	CLAMP WELDMENT, MOTOR MOUNT BUSHING	086200	3
	BUSHING ASSEMBLY, MOTOR MOUNT PIVOT		
9	Spacer, Motor Mount Pivot	P12164	1
10	Bushing, Rubber Motor Mount Pivot	P05041	1
11	NUT, 3/8-16 HEX NYLON LOCK	F05010-10	6

### 4.6 Drive and Alternator Assembly

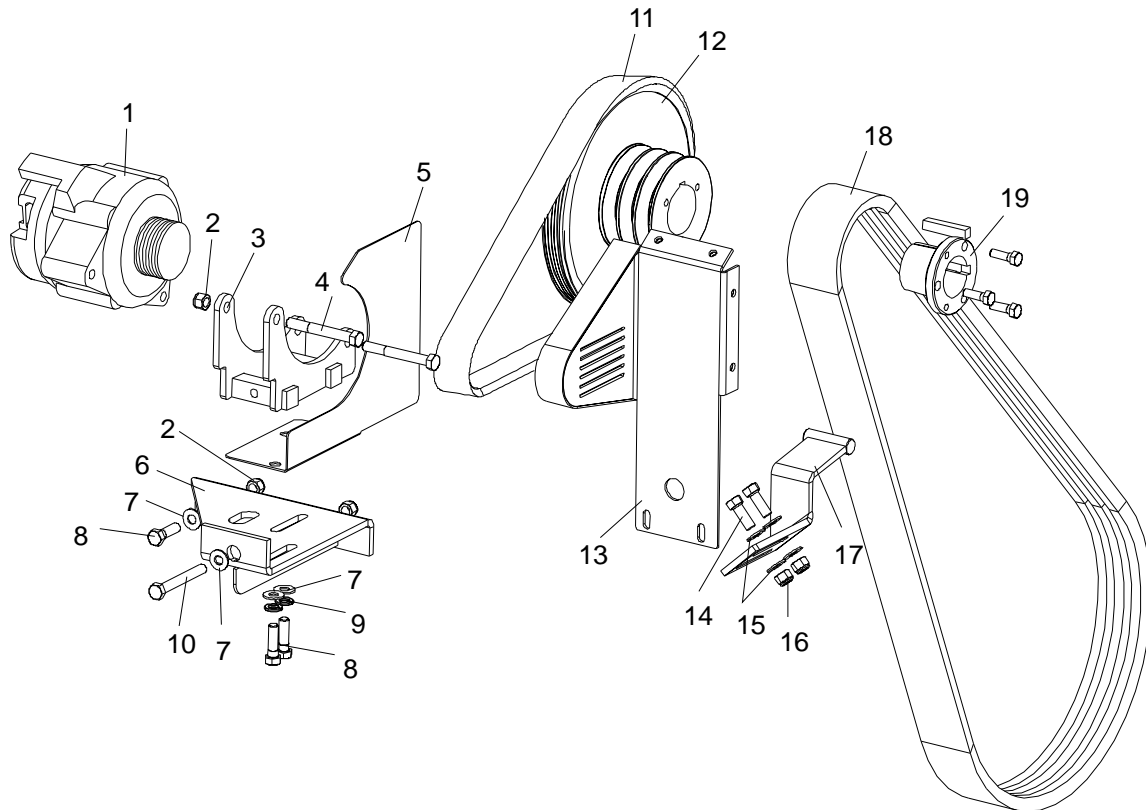

3H0405B

REF	DESCRIPTION (◆ Indicates Parts Available In Assemblies Only)	PART #	QTY.
1	ALTERNATOR, 105AMP	015473	1
	WIRE ASSEMBLY, ALTERNATOR PLUG 105 AMP	015932	1
2	NUT, 3/8-16 HEX NYLON LOCK	F05010-10	2
3	BRACKET, E25 ALTERNATOR	023596	1
4	BOLT, 3/8-16 X 3" HEX HEAD GRADE 5	F05007-73	2
5	GUARD, REAR ALTERNATOR	023584	1
6	BASE WELDMENT, E25 ALTERNATOR	023597	1
7	WASHER, 10,5 FLAT	F81055-1	5
8	BOLT, 3/8-16 X 1 1/4" HEX HEAD GRADE 5	F05007-123	4
9	WASHER, 10,2 SPLIT	F81055-2	2
10	BOLT, 3/8-16 X 3" FULL THREAD HEX HEAD	F05007-1	1
11	BELT, 6PK1015 105AMP ALTERNATOR	015474	1
12	PULLEY, POLY GROOVE ELECTRIC	015348	1

# 4 Replacement Parts

## *Drive and Alternator Assembly*

---

13	GUARD WELDMENT, ALTERNATOR	086461-1	1	
14	BOLT, 3/8-16 X 1" HEX HEAD	F05007-7	2	
15	WASHER, 10,5 FLAT	F81055-1	4	
16	NUT, 3/8-16 HEX NYLON LOCK	F05010-10	2	
17	BRACKET WELDMENT, LOWER DRIVE BELT SUPPORT	085922-1	1	
	BRACKET WELDMENT, UPPER DRIVE BELT SUPPORT	085865-1	1	
18	BELT, 3BX72 DRIVE	014085	1	
19	BUSHING, 1 5/8" P1	014009	1	

## 4.7 Motor Pulley Guards

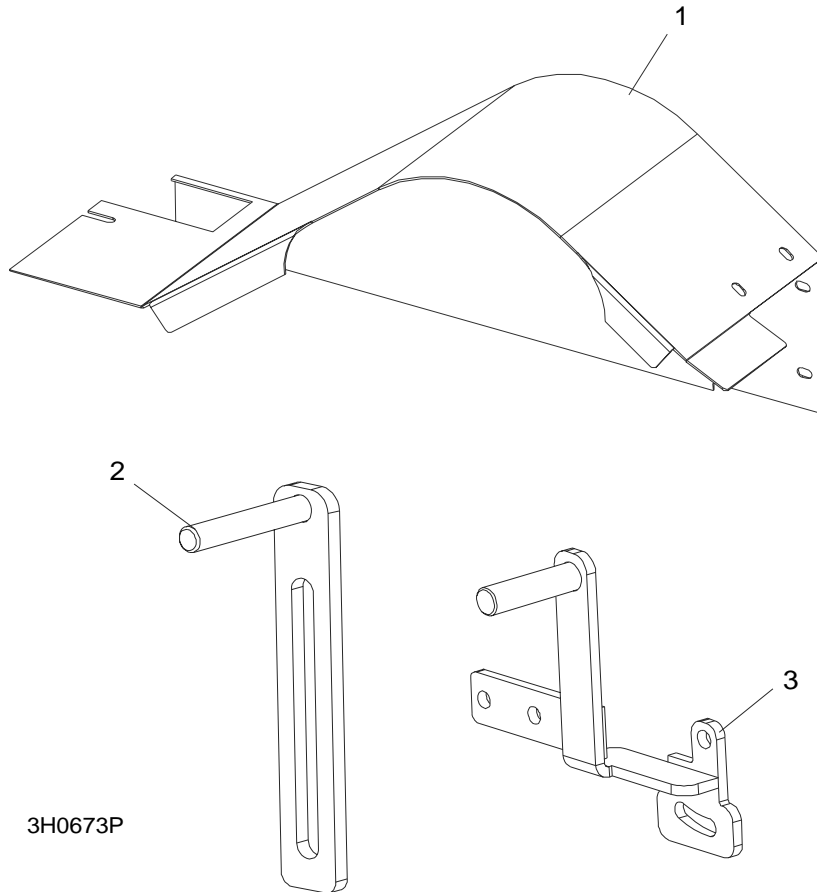

REF	DESCRIPTION (◆ Indicates Parts Available In Assemblies Only)	PART #	QTY.	
1	GUARD, E25 SIDE MOTOR PULLEY	086044-1	1	
2	SUPPORT, DRIVE BELT UPPER	085865-1	1	
3	SUPPORT, DRIVE BELT LOWER	085922-1	1	



## **SECTION 5 ELECTRICAL INFORMATION**

### **5.1 Electrical Symbol Diagram, E25**

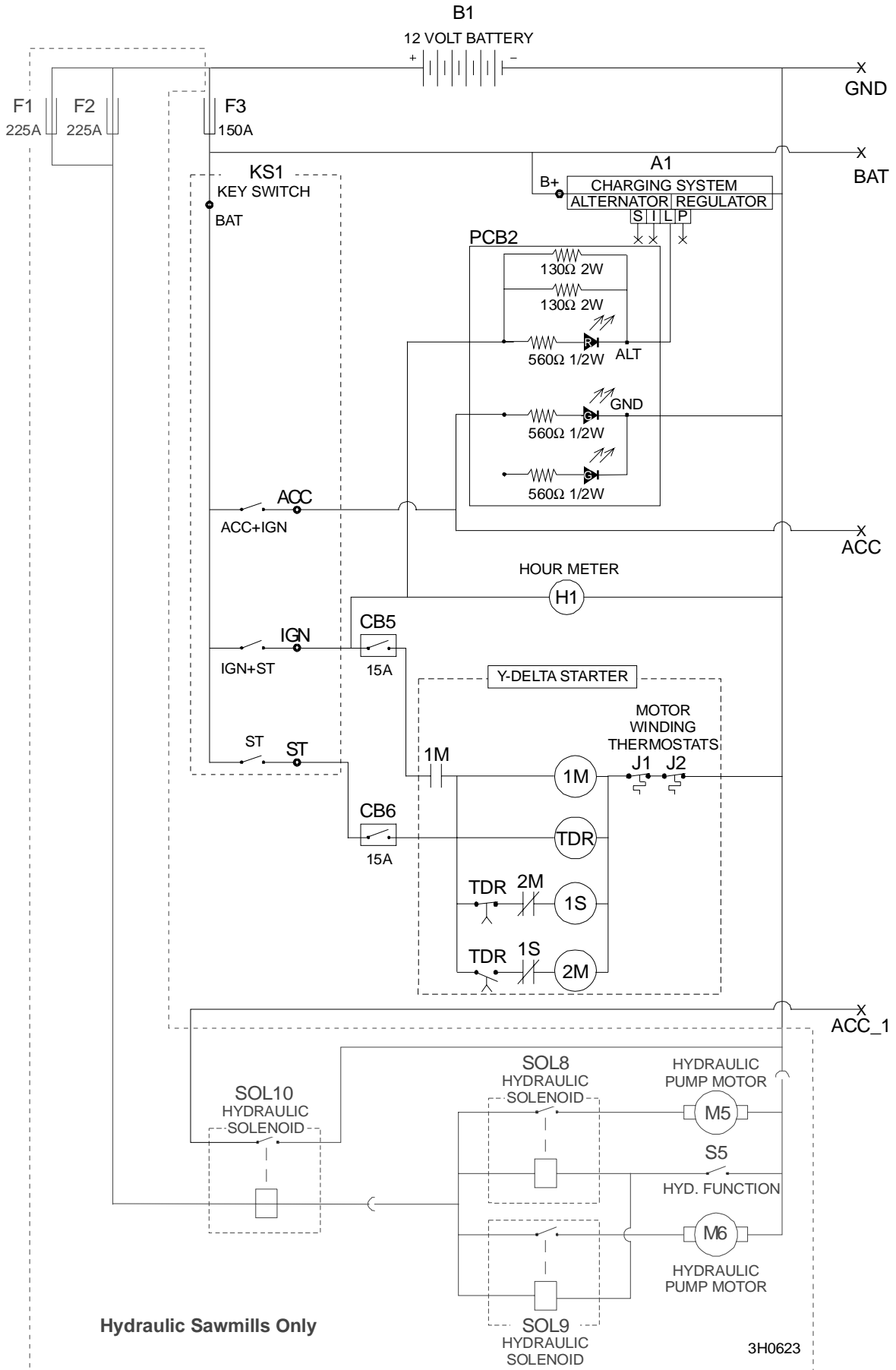

FIG. 5-1 E25 SYMBOL DIAGRAM (PAGE 1 OF 2).



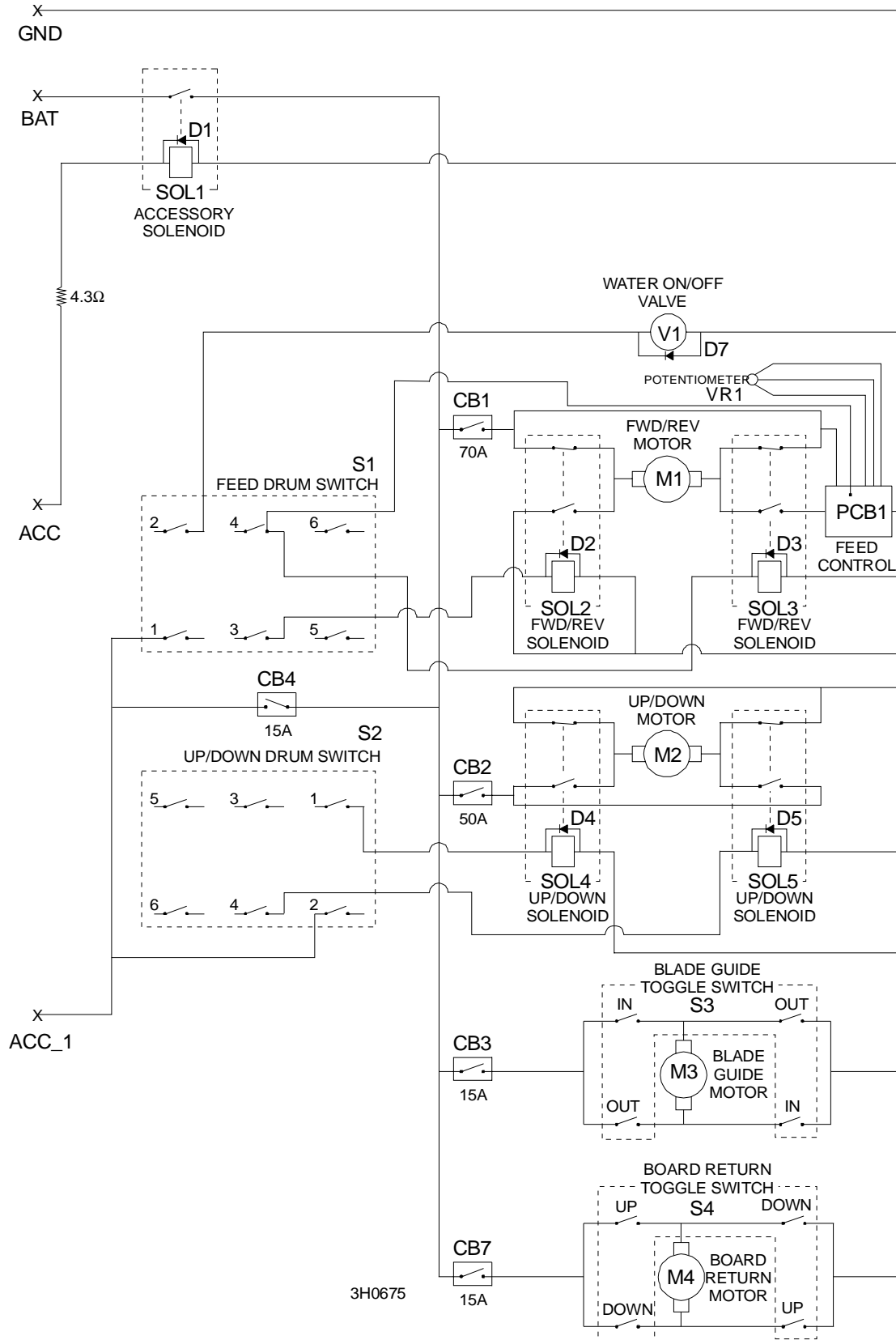

FIG. 5-2 E25 SYMBOL DIAGRAM (PAGE 1 OF 2).

# 5 Electrical Information

## Electrical Components, E25

### 5.2 Electrical Components, E25

Component	Manufacturer Part No.	Manufacturer	Wood-Mizer Part No.	Description
A1	023730	Wood-Mizer	023730	Alternator, 140 Amp
B1	1231PMF	Deka	015475	Battery, 12 Volt (See Battery Specifications)
CB1	70-1648-009	Mech. Prod.	015527	Breaker, 70 Amp Manual Reset Panel Mount, Pwr Feed
CB2	1648-009-050-006	Mech. Prod.	021256	Breaker, 50 Amp Manual Reset Panel Mount, Up/Down
CB3	CH30407-15	Cole-Hersee	E20430	Breaker, 15 Amp Manual Reset, Blade Guide
CB4	CH30407-15	Cole-Hersee	E20430	Breaker, 15 Amp Manual Reset, Accessory
CB5	CH30407-15	Cole-Hersee	E20430	Breaker, 15 Amp Manual Reset, Ignition
CB6	CH30407-15	Cole-Hersee	E20430	Breaker, 15 Amp Manual Reset, Start
CB7	CH30407-15	Cole-Hersee	E20430	Breaker, 15 Amp Manual Reset, Board Return
D1 - D5	015426	Wood-Mizer	015426	Diode Assembly, Solenoid Coil Chassis
D7	024123	Wood-Mizer	024123	Diode Assembly, Inductive Kick Protection
F1, F2 <sup>1</sup>	RL-225	Gould	P11550	Fuse Link, 225 Amp, 250 Volt For Hydraulic + 12 Volt Circuit
F3	RL-150	Gould	023361	Fuse Link, 150 Amp, 250 Volt For Main + 12 Volt Starter, Alternator
H1	T14BH517BC9	ENM Corp.	015401	Hour Meter, 12 Volt, Low Power T14 Series
KS1	121801	General	P04350	Key Switch, 4-position (Accessory, Off, Ignition, Start)
M1	108677.00	Leeson	024169	Motor, 3/4HP 12VDC TEFC Power Feed w/o Base
M2	108678.00	Leeson	015174	Motor, 3/4HP 12VDC TEFC Up/Down w/Base
M3	P09698-1	Klauber	A10365	Motor, 12 Volt Blade Guide Arm 53:1 Gear
M4	P09698-1	Klauber	A10365	Motor, 12 Volt Board Return 53:1 Gear
M5, M6 <sup>1</sup>	8111	Monarch	P09955	Motor, 12 Volt Hydraulic Pump
PCB1	024458	Wood-Mizer	024458	Circuit Board, Control Box Power Feed
PCB2	015416	Wood-Mizer	015416	Circuit Board, LED Circuit (Gas/Elec)
S1	2601-AF2-S11	Square D	E20439	Drum Switch, Power Feed Fwd/Reverse Motor
S2	2601-AF2-S12	Square D	E20440	Drum Switch, Up/Down Motor
S3	34-591Q	Pollak	024200	Toggle Switch, Blade Guide In/Out Motor
S4	34-591Q	Pollak	024200	Toggle Switch, Board Return Motor
S5 <sup>1</sup>	024198	Wood-Mizer	024198	Switch, Hydraulic Pump Levers
SOL1	120-943	Stancor	P10449	Solenoid, Accessory Circuit
SOL2-SOL5	586-911	Stancor	015417	Solenoid, 200A 12V DPST
SOL8,SOL9, SOL10 <sup>1</sup>	586-902	Stancor	015470	Solenoid, 200A 12V SPST Hydraulic Pump Motor
V1	S24C-6V 12VDC	Atkomatic Valve Co.	014165	Valve, Waterlube Solenoid
VR1	024450-1	Wood-Mizer	024450-1	Potentiometer, Variable Resistance Power Feed

**TABLE 5-1**

<sup>1</sup> Component applies to hydraulic models only.

### 5.3 Battery Specifications, E25

Group No.	Type No.	Performance Level		Approx. Weight (Wet)	Maximum Overall Dimensions		
		Cranking Performance	Reserve Capacity		Length	Width	Height
31	1231PMF	1100	195	60 lb. (27.2 Kg)	13" (330 mm)	6 3/4" (171 mm)	9 1/2" (241 mm)

**TABLE 5-2**



## **5.4 Electrical Wiring Diagram, E25**

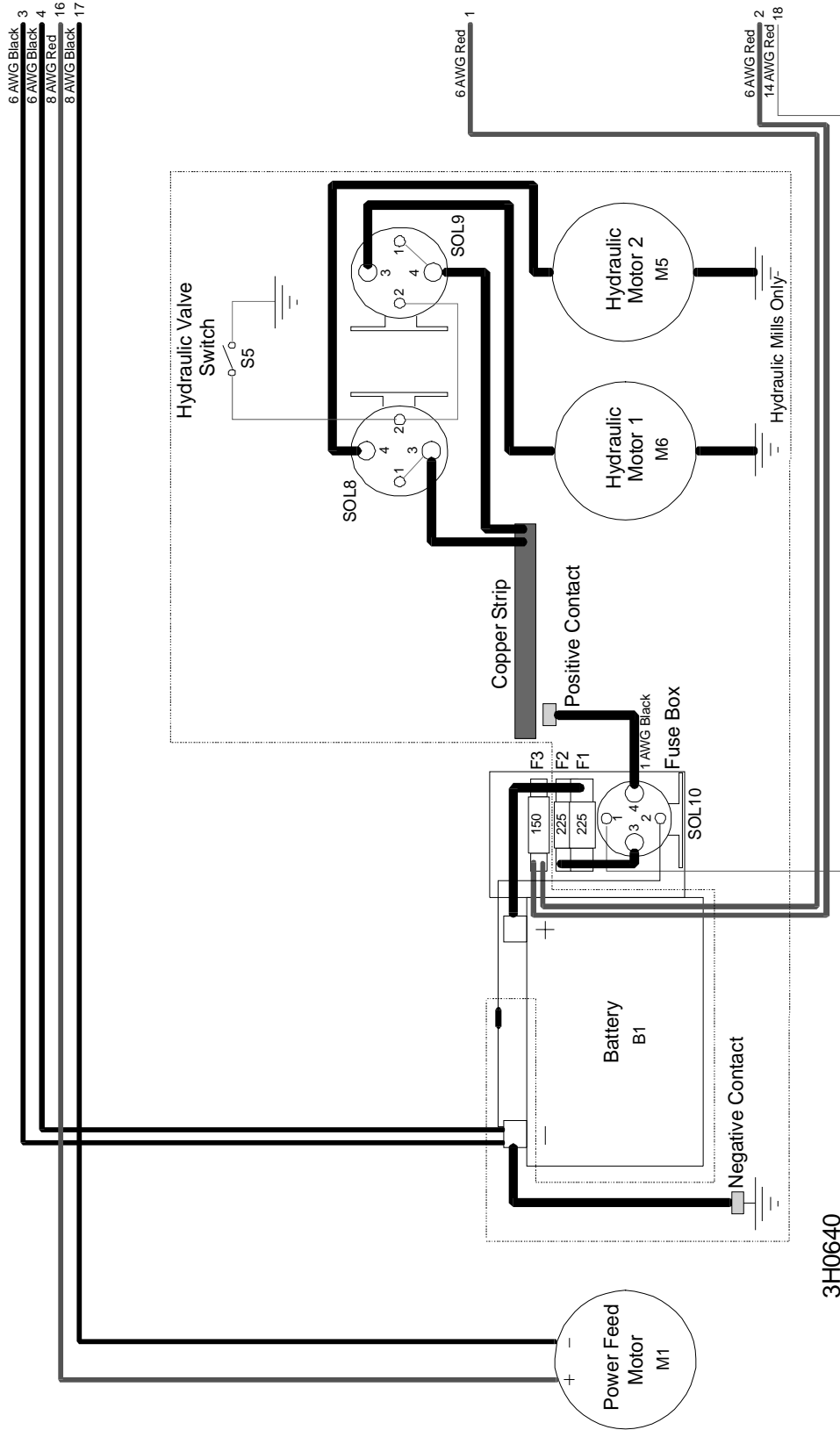

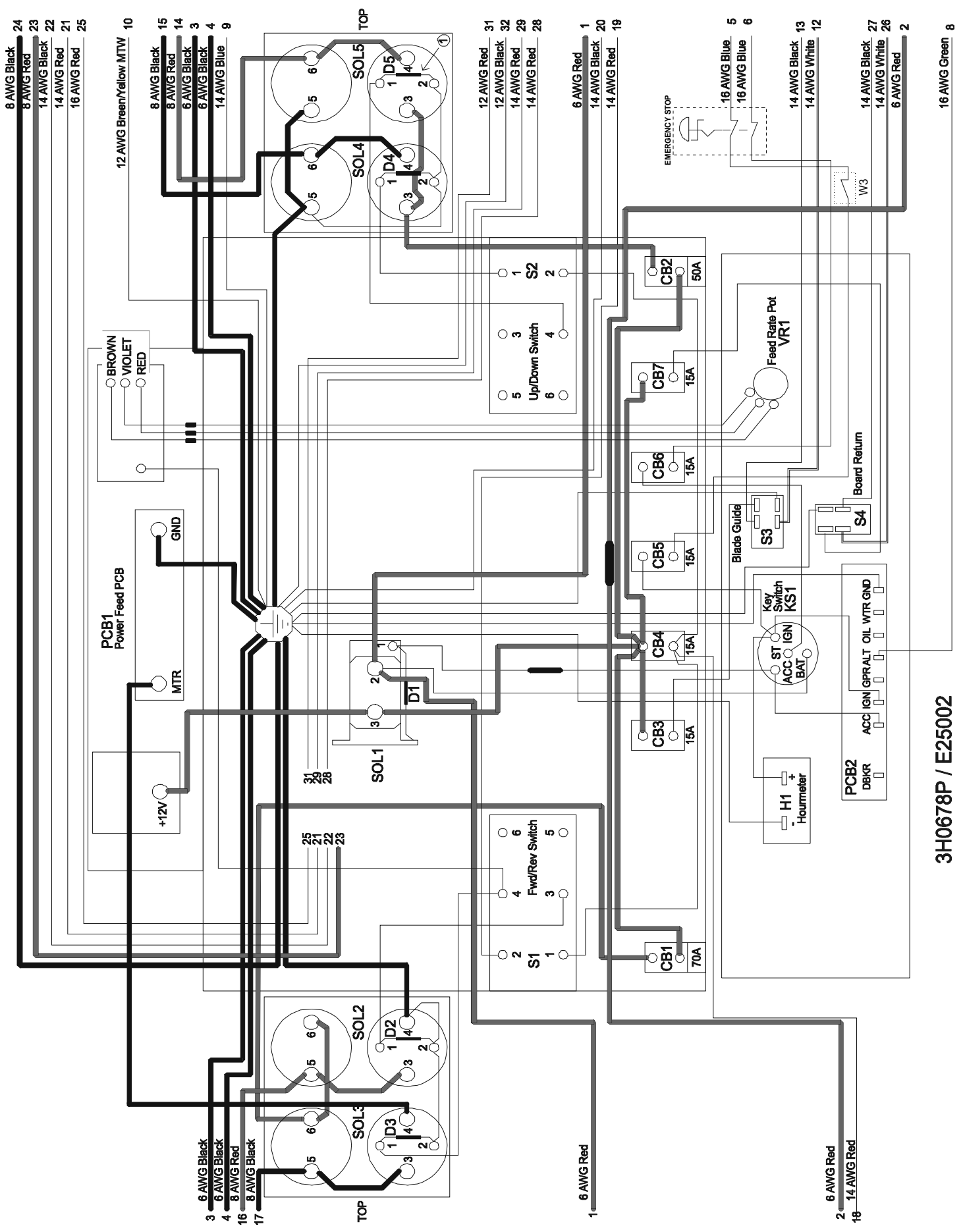

3H0678P / E25002

# Electrical Wiring Diagram, E25

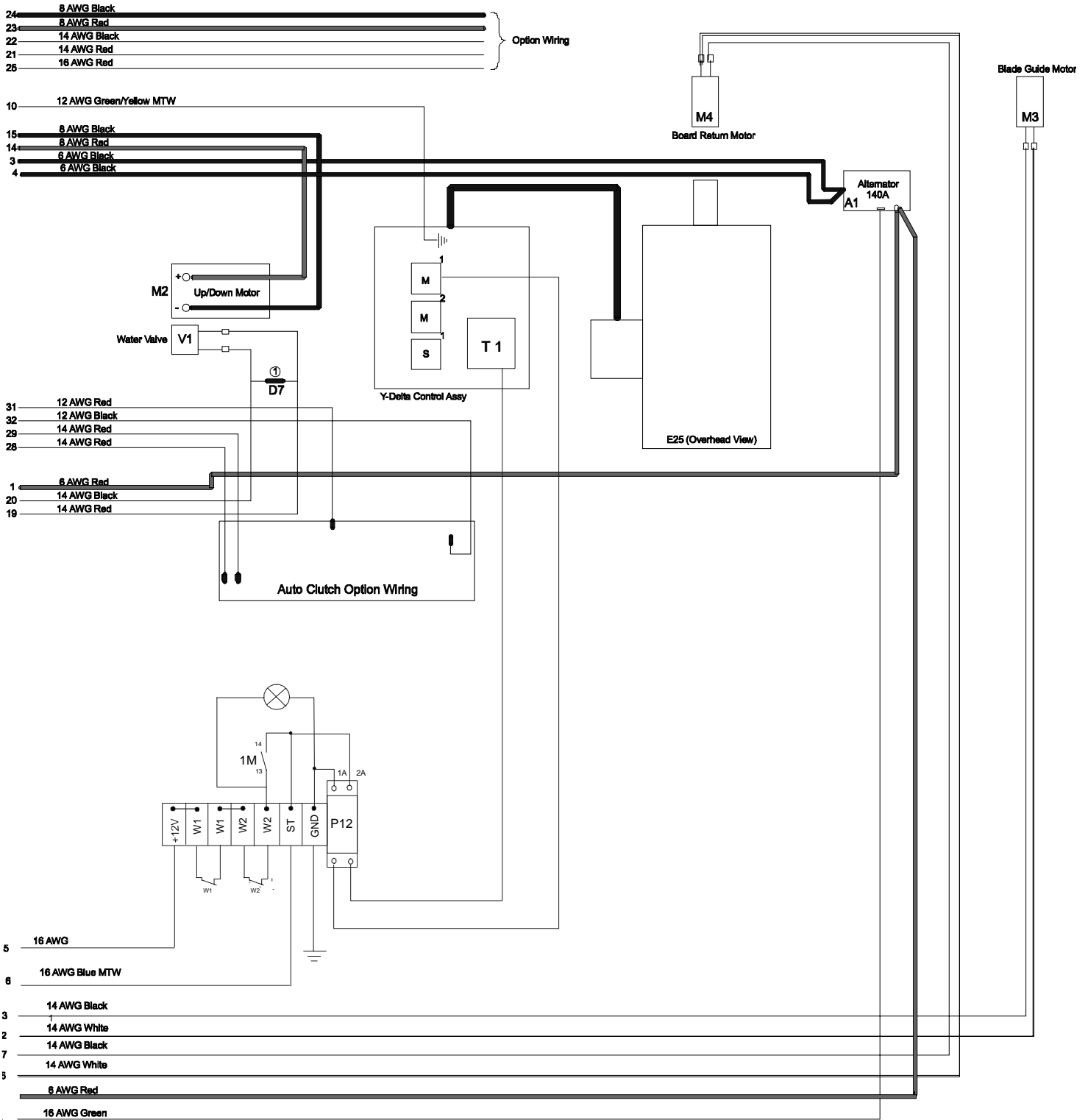

3H0679P / E25001