

D38 Engine

Safety, Operation, Maintenance & Parts Manual

LT40 Series DC

rev. D1.01



Safety is our #1 concern! Read and understand all safety information and instructions before operating, setting up or maintaining this machine.

February 1998

Form #662

Table of Contents

Section-Page

SECTION 1	SAFETY & GENERAL INFORMATION	1-1
1.1	Refueling	1-1
1.2	Engine Operation.....	1-2
1.3	Battery Handling.....	1-4
1.4	General Information	1-5
SECTION 2	OPERATION	2-1
2.1	Starting The Engine.....	2-1
2.2	Cold Weather Operation.....	2-3
SECTION 3	MAINTENANCE	3-1
3.1	Engine Oil & Filter	3-2
3.2	Air Cleaner	3-3
3.3	Cooling System	3-4
3.4	Primary Fuel Filter	3-5
3.5	Battery	3-6
3.6	Alternator Belt.....	3-6
3.7	Drive Belt Adjustment.....	3-7
3.8	Clutch Handle Adjustment	3-9
3.9	Miscellaneous Maintenance	3-10
3.10	RPM Adjustments	3-11
3.11	Storage.....	3-13
SECTION 4	REPLACEMENT PARTS	4-1
4.1	How To Use The Parts List	4-1
4.2	Sample Assembly	4-1
4.3	Fuel Tank.....	4-2
4.4	Engine Mount Assembly	4-3
4.5	Engine Assembly.....	4-4
4.6	Primary Fuel Filter	4-6
4.7	Alternator Assembly.....	4-7
4.8	Relay/Throttle Assembly.....	4-9
4.9	Muffler Assembly.....	4-11
4.10	Drive Assembly.....	4-12
4.11	Radiator Assembly	4-13
4.12	Engine/Muffler Guards.....	4-14
4.13	Engine Pulley Guards	4-15
4.14	Air Cleaner Assembly	4-16
SECTION 5	ELECTRICAL INFORMATION	5-1
5.1	Electrical Symbol Diagram, Super D38	5-1
5.2	Electrical Components, Super D38	5-4

Table of Contents

Section-Page

5.3	Battery Specifications, Super D38	5-6
5.4	Electrical Wiring Diagram, D38.....	5-1

SECTION 1 SAFETY & GENERAL INFORMATION



IMPORTANT! This manual is provided as a supplement to the equipment manufacturer's manuals. This manual takes into account the specific use of engines on the Wood-Mizer sawmill. Only safety, maintenance, and operating procedures that are not provided by the manufacturer are supplied in this manual. Refer to the manufacturer's manual before attempting to operate this equipment.



This symbol calls your attention to instructions concerning your personal safety. Be sure to observe and follow these instructions. This symbol accompanies a signal word. The word **DANGER** indicates an imminently hazardous situation which, if not avoided, will result in death or serious injury. **WARNING** suggests a potentially hazardous situation which, if not avoided, could result in death or serious injury. **CAUTION** refers to potentially hazardous situations which, if not avoided, may result in minor or moderate injury to persons or equipment. Read all safety instructions before operating this equipment and observe all safety warnings!

1.1 Refueling



DANGER! Due to the flammable nature of fuel and oil, never smoke, weld, grind or allow sparks near your engine or storage tanks, especially during times of fueling.

DANGER! Never allow fuel to spill on a hot engine during fueling operations or otherwise. The hot temperature of your engine could induce a fire or explosion.



WARNING! Store gasoline away from sawdust and other flammable materials. Failure to do so may result in serious injury.

1.2 Engine Operation



DANGER! Operate your engine/machine only in well ventilated areas. The exhaust gases of your engine can cause nausea, delirium and potentially death unless adequate ventilation is present.

DANGER! Never operate an engine with a fuel or oil leak. The leaking fuel or oil could potentially come in contact with hot surfaces and ignite into flames.

DANGER! Engine components can become very hot during operation. Avoid contact with any part of a hot engine. The exhaust components of your engine are especially hot during and following operation. Contact with hot engine components can cause serious burns. Therefore, never touch or perform service functions on a hot engine. Allow the engine to cool sufficiently before beginning any service function.

DANGER! Always be aware of and take proper protective measures against rotating shafts, pulleys, fans, etc. Always stay a safe distance from rotating members and make sure that loose clothing or long hair does not engage rotating members resulting in possible injury.

DANGER! Always be sure the blade is disengaged and all persons are out of the path of the blade before starting the engine or motor. Failure to do so will result in serious injury.



WARNING! Do not for any reason adjust the engine drive belts or belt support bracket with the engine running. Doing so may result in serious injury.

WARNING! Do not operate engine without proper and operational spark arrester/muffler. Sparks emitted from the engine exhaust could ignite surrounding materials, causing serious injury or death.

WARNING! Remove the blade before performing any engine service. Failure to do so may result in serious injury.



WARNING! Always disconnect the machine battery cables before performing service functions. Diesel engines by default require diesel fuel and lubricating oil for operation. Both diesel fuel and lubricating oil are flammable. Disconnection of the battery cables will reduce the possibility of sparks with potentially resultant fires or explosions.

WARNING! Be sure the power feed switch is in the neutral position before turning the key switch to the on (#1) or accessory (#3) position. This prevents accidental carriage movement, which may cause serious injury or death.

WARNING! Always wear proper and necessary safety equipment when performing service functions. Proper safety equipment includes eye protection, breathing protection, hand protection and foot protection.

WARNING! The engine exhaust from this product contains chemicals known to the State of California to cause cancer, birth defects or other reproductive harm.



IMPORTANT! Always dispose of coolant, oil, fuel, oil filters and fuel filters in a responsible manner and in conformance with local, state and federal regulations.



CAUTION! Do not crank starter for more than 7 seconds at one time during starting attempts. Damage to the engine may result.

CAUTION! During the initial 50 hours, do not exceed 70% of the maximum rated power. Damage to the engine may result.

CAUTION! Do not adjust the high-end RPM above 3200. Doing so may cause damage to the engine.

1.3 Battery Handling



DANGER! Batteries expel explosive gases. Keep sparks, flames, burning cigarettes, or other ignition sources away at all times. Always wear safety goggles and a face shield when working near batteries. Failure to do so will cause serious injury.¹



WARNING! Charge the battery in a well ventilated area. Do not attempt to charge a frozen battery.

WARNING! Use extreme care to avoid spilling or splashing electrolyte (which is dilute sulfuric acid) as it can destroy clothing and burn the skin. If electrolyte is spilled or splashed on clothing or the body, it should be neutralized immediately and then rinsed with clean water. A solution of baking soda, or household ammonia, and water may be used as a neutralizer.

Electrolyte splashed into the eyes is extremely dangerous. If this should happen, force the eye open and flood it with cool, clean water for approximately fifteen minutes. A doctor should be called immediately when the accident occurs and “on-the-spot” medical attention given if possible. If a doctor cannot come to the scene of the accident immediately, follow his instructions concerning actions to take. Do not add eye drops or other medication unless advised to do so by the doctor. Do not place a battery or acid within the reach of children. If acid (electrolyte) is taken internally drink large quantities of water or milk. Follow with milk of magnesia, beaten egg or vegetable oil. Call a physician immediately.

If electrolyte is spilled or splashed on any surface of the machine, it should be neutralized and rinsed with clean water.¹

1. Battery Council International, copyright 1987

1.4 General Information



IMPORTANT! Read the engine manual for instructions and safety precautions before operating the engine.

For use with the Wood-Mizer sawmill, the radiator, air cleaner, alternator, and starter used differ from Lombardini's standard components.

See **Figure 1-1**. The main components of the diesel engine are shown.

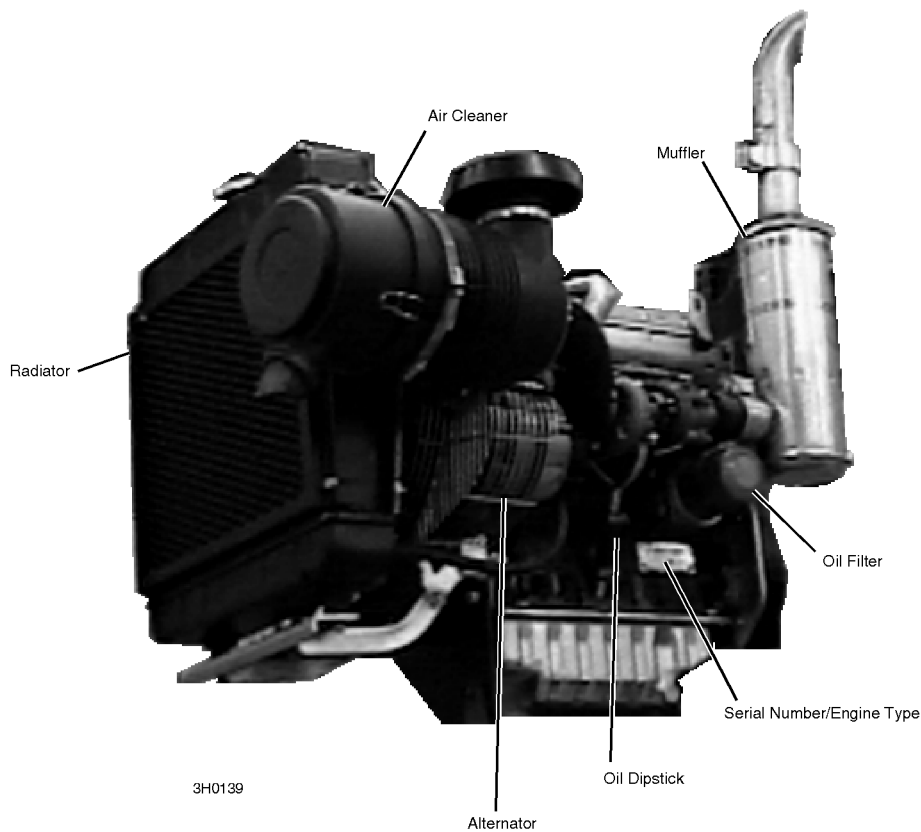











FIG. 1-1

SECTION 2 OPERATION

2.1 Starting The Engine

Engine Control Lights

See **Figure 2-1**. The following indicator lights are located on the sawmill control panel. See the manufacturer's engine manual for troubleshooting tips.

- 
Alternator Charge Indicator: Lights up if the alternator is not charging the battery.
 **NOTE:** Indicator also lights up when engine is started and remains lit until engine initially reaches approximately 1300RPM.
- 
Engine Temperature Indicator: Lights up if the engine is overheating.

- 
Key Switch Indicator: Lights up when the key is in either the on or accessory (#1 or #3) position.

- 
Oil Indicator: Lights up if the oil pressure is too low.

- 
Glow Plug Indicator: Lights up after the key has been turned to the on (#1) position.

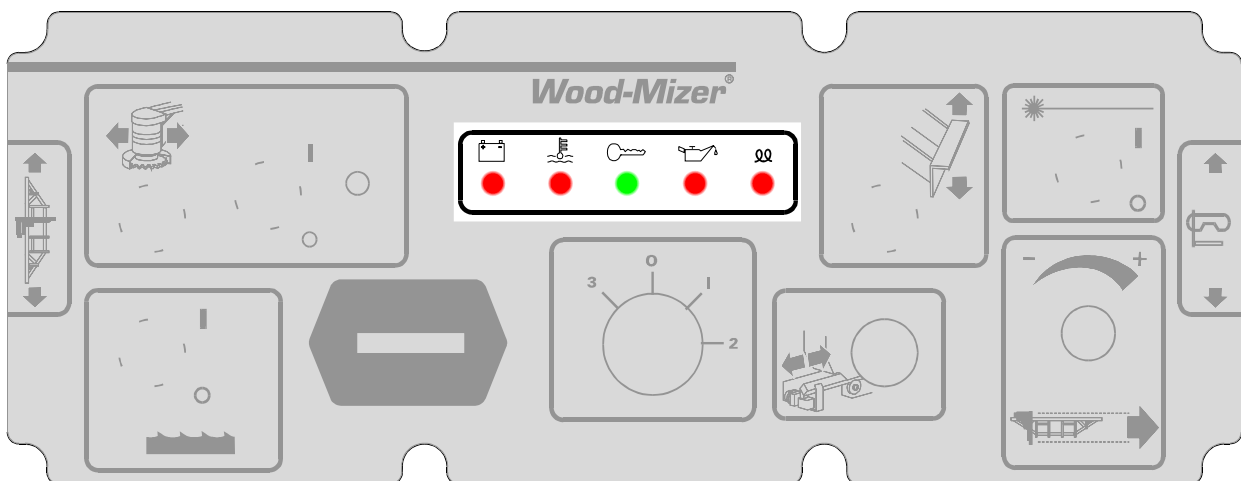

FIG. 2-1

2 Operation

Starting The Engine

See Table 2-1. **IMPORTANT!** The glow plug sensing relay is disconnected to provide manual control of glow plug operation. See the table for recommended glow plug on times.

On Times For Manually Operated Glow Plugs	
Ambient Temperature	Suggested Glow Plug On Time
Less Than 32° F (0° C)	30 Seconds
32 - 60° F (0 - 15° C)	25 Seconds
60 - 80° F (15 - 27° C)	15 Seconds
Above 80° F (27° C)	10 Seconds

TABLE 2-1

NOTE: The glow plug light will stay on indefinitely when the key is in the pre-start (1) position. The glow plug light will go out after the engine is started.



CAUTION! Avoid leaving the key in the pre-start (1) position for more than 30 seconds while the engine is not running. Doing so will drain the sawmill battery which may reduce its service life.

Engine Start



DANGER! Always be sure the blade is disengaged and all persons are out of the path of the blade before starting the engine or motor. Failure to do so will result in serious injury.



WARNING! Be sure the power feed switch is in the neutral position before turning the key switch to the on (#1) or accessory (#3) position. This prevents accidental carriage movement, which may cause serious injury or death.



CAUTION! Do not crank starter for more than 7 seconds at one time during starting attempts. Damage to the engine may result.

1. See engine manual lubricating oil for specific temperature-range oil recommendations.
2. Use #2 or better quality diesel fuel for above freezing starting. Use a #1 quality diesel fuel for below freezing starting.
3. Turn the key switch on the control panel to the on (#1) position.
4. Wait the recommended glow plug on time ([See Table 2-1.](#))
5. Turn the key switch to the start (#2) position and release.

Engine Shutoff

Turn the key switch to the off (#0) position.

2.2 Cold Weather Operation

When sawing in extremely cold weather, you may need to use a different engine oil. Lombardini recommends using 0W30 for operating temperatures between -13° F (-25 C) and -31° F (-35° C). When sawing in temperatures below -31° F (-35° C), Lombardini recommends using a synthetic-based oil such as Mobil Delvac 1 5W40.

Wood-Mizer also offers an accessory engine water heater for Lombardini diesel engines. The heater unit installs around the lower radiator hose. When plugged into a grounded 120V outlet, the heater will keep the engine coolant warm enough to allow easy starts in cold climates.

SECTION 3 MAINTENANCE



IMPORTANT! This manual only provides information about additional procedures or procedures to be performed at different time intervals than found in the engine manufacturer's manuals. Refer to the [manufacturer's manual](#) for complete maintenance instructions.



DANGER! Engine components can become very hot during operation. Avoid contact with any part of a hot engine. The exhaust components of your engine are especially hot during and following operation. Contact with hot engine components can cause serious burns. Therefore, never touch or perform service functions on a hot engine. Allow the engine to cool sufficiently before beginning any service function.



WARNING! Remove the blade before performing any engine service. Failure to do so may result in serious injury.

WARNING! Always disconnect the machine battery cables before performing service functions. Diesel engines by default require diesel fuel and lubricating oil for operation. Both diesel fuel and lubricating oil are flammable. Disconnection of the battery cables will reduce the possibility of sparks with potentially resultant fires or explosions.

WARNING! Always wear proper and necessary safety equipment when performing service functions. Proper safety equipment includes eye protection, breathing protection, hand protection and foot protection.



This symbol identifies the interval (hours of operation) at which each maintenance procedure should be performed. "AR" signifies maintenance procedures which should be performed as required.

3.1 Engine Oil & Filter

See Figure 3-1. The following chart details lubricating oil viscosity as a function of ambient temperature. Select the lubricating oil viscosity based upon the prevailing temperature range expected. If your application will be subject to large ambient temperature ranges during a given oil change interval, select the lubricating oil viscosity based upon the highest temperature expected. Should the prevailing ambient temperatures change during a given oil service period interval, and the lubricating oil within the engine is reflective of a lower temperature range, the lubricating oil should be changed to reflect the prevailing temperature.

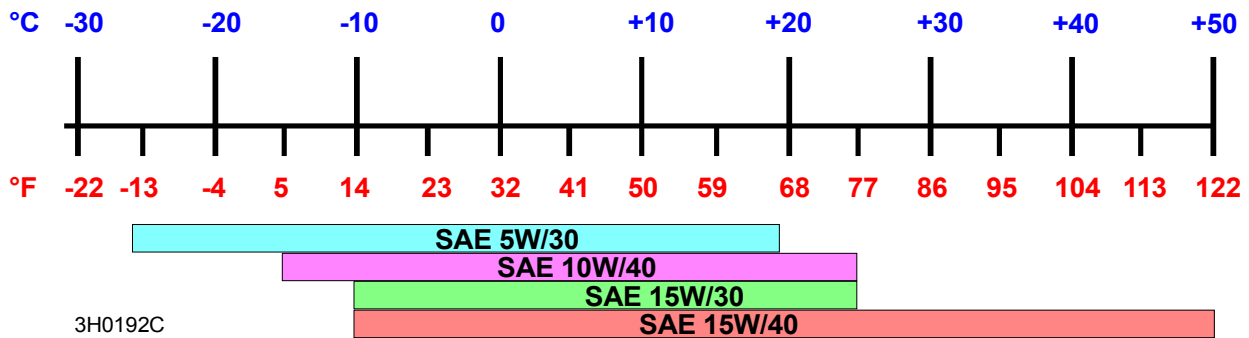

FIG. 3-1

NOTE: The use of straight weight lubricating oils such as SAE 40, SAE 30, etc. is not recommended for Lombardini diesel engines.

Lombardini recommends that only API (American Petroleum Institute) grades 'CD' or higher be used within Lombardini diesel engines. In addition to the API rating, lubricating oils should also meet or exceed MIL-L-2104D. Without respect to brand name, lubricating oil meeting API grade 'CD' and sourced from a reputable supplier are acceptable for use within Lombardini diesel engines.

The use of "SEMI-SYNTHETIC" lubricating oils meeting the grade and viscosity guidelines presented above is acceptable and may reduce engine wear rates due to the superior characteristics of the "SEMI-SYNTHETIC" oil with respect to mineral based engine lubricating oils.

Lombardini does not recommend the use of ANY oil additive other than those included within the respective manufacturer oil blends. Under no circumstances should oil additives claiming "teflon", "molecular adhesion", low wear rates etc. be added. These aftermarket oil additives may actually break down the recommended lubricating oil chemical properties resulting in accelerated engine wear.

When operating in temperatures below those specified in the chart, [See Section 2.2](#).

Oil capacity (including oil filter) is 4.5 quarts, or 4.3 liters.

8

Check the oil level every 8 hours of operation. Add oil as necessary.

125

Change the oil and replace the oil filter after the first 50 hours of operation. Change the oil every 125 hours and replace the oil filter every 250 hours thereafter.



IMPORTANT NOTE! Before reinstalling the clean oil filter, wipe all dirt and oil deposits from the oil filter receptacle.

3.2 Air Cleaner

8

Empty the air debris collector every 8 hours of operation.

See Figure 3-2. Squeeze the rubber tip of the collector to open it. After all debris has been emptied from the collector, release the tip and allow it to close.



WARNING! Always wear proper and necessary safety equipment when performing service functions. Proper safety equipment includes eye protection, breathing protection, hand protection and foot protection.

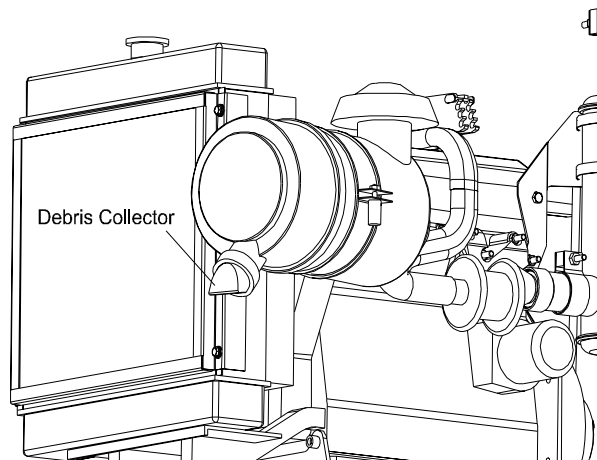

FIG. 3-2

AR

Replace the air filter when air filter indicator shows need (or every year). The air cleaner used on the Lombardini Diesel for Wood-Mizer sawmill applications is a special, non-standard filter which becomes more efficient with use. There is no need for periodic cleaning or servicing.

See Figure 3-3. The indicator is located on the side of the air cleaner housing, behind the radiator. A red band will appear in the sight window when the air restriction is at its maximum limit. Change the air filter and push the reset button on the indicator.

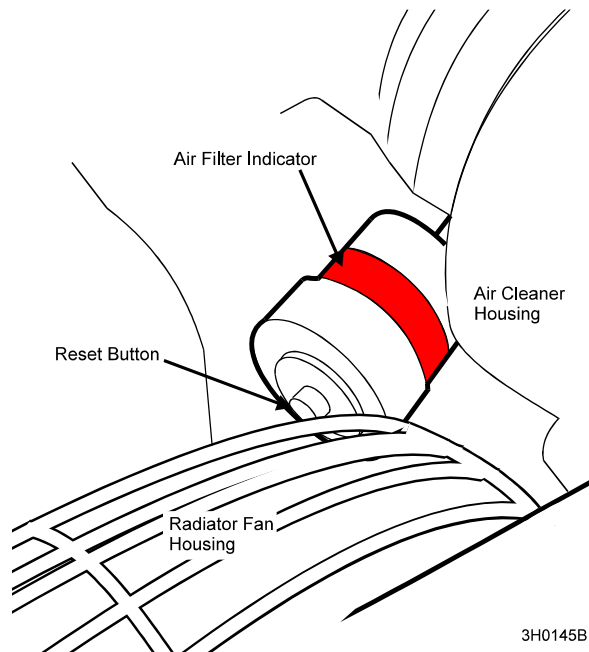

FIG. 3-3

3.3 Cooling System

- 8 Check the coolant level every 8 hours of operation.
- 8 Check the radiator fins every 8 hours of operation.
- 250 Clean the radiator fins every 250 hours of operation.
- 1000 Replace the coolant every 1000 hours of operation or every 2 years, whichever comes first. Use a mixture of 50% antifreeze and 50% water.

3.4 Primary Fuel Filter

1500

See Figure 3-4. Replace the primary fuel filter cartridge every 1500 hours or one year of operation. After replacing the filter cartridge, loosen the air bleed screw and operate the fuel pump bail until fuel begins to flow from the valve and is free of air bubbles. Tighten the bleed screw. Inspect the water separator bowl periodically and drain the bowl as required by turning the drain cap counterclockwise as viewed from the bottom.

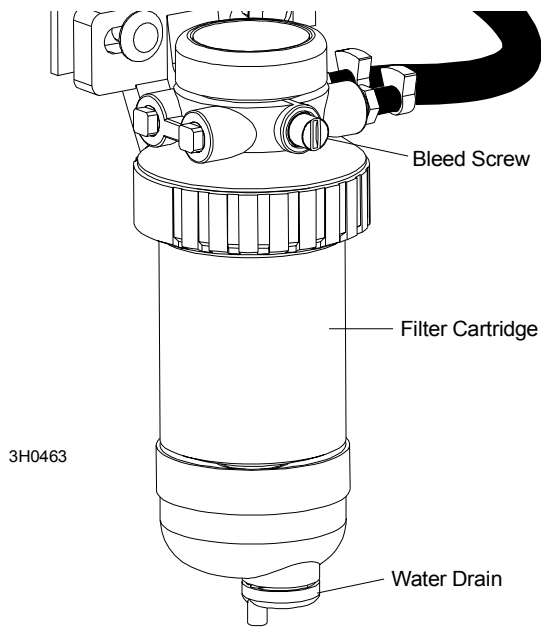

FIG. 3-4

3.5 Battery



Check the battery electrolyte level every 50 hours of operation. See manufacturer's manual for instructions.



DANGER! Batteries expel explosive gases. Keep sparks, flames, burning cigarettes, or other ignition sources away at all times. Always wear safety goggles and a face shield when working near batteries. Failure to do so will cause serious injury.¹

3.6 Alternator Belt



Check the alternator belt tension every 500 hours. Also check the alternator belt for tension and wear when battery is not charging properly or when the alternator belt is squealing. Adjust as needed.



Replace the alternator belt every 1000 hours.

1. Battery Council International, copyright 1987

3.7 Drive Belt Adjustment



WARNING! Do not for any reason adjust the engine drive belts or belt support bracket with the engine running. Doing so may result in serious injury.

50

Check the drive belt tension after the first 20 hours, and every 50 hours thereafter. When engaged, the drive belt should have 7/16" (11 mm) deflection with a 15 lb. deflection force. Always be sure to check the drive belt support after adjusting drive belt tension.

To adjust drive belt tension:

1. Remove the two belt covers located underneath the engine.
2. Loosen the drive belt turnbuckle jam nuts. Turn the turnbuckle counterclockwise (as viewed from the top) to tighten the belts, clockwise to loosen the belts.

See Figure 3-5.

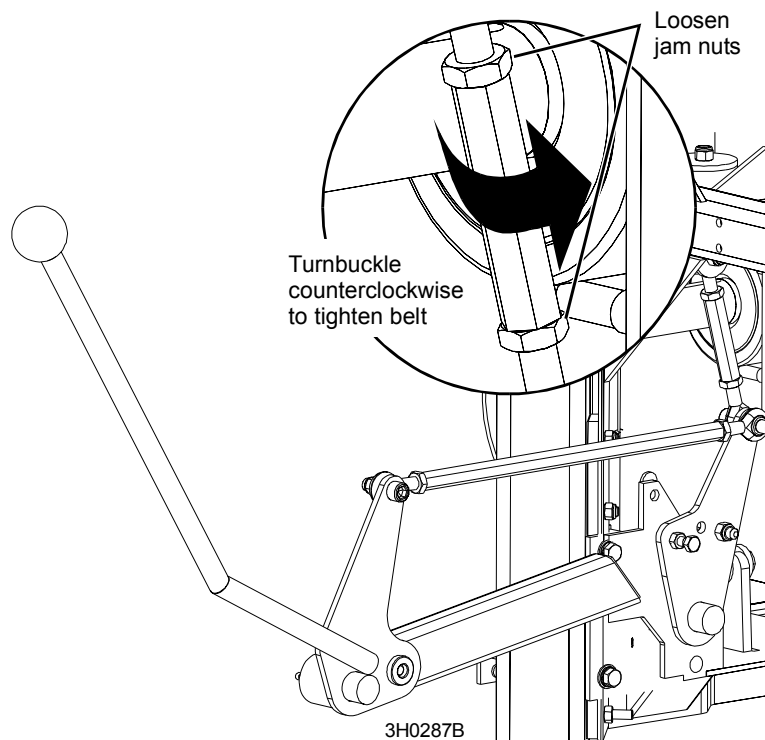

FIG. 3-5

AR

Periodically check all belts for wear. Replace any damaged or worn belts as needed.



Adjust the drive belt support as needed. The drive belt support is designed to extend belt life. The bracket should be adjusted to NOT touch the drive belt when the clutch handle is engaged (down position), AND to hold the drive belt away from the engine pulley when the clutch handle is disengaged (up position).

See Figure 3-6. To adjust the drive belt support:

1. Make sure the motor is not running. Loosen the adjustment bolt.
2. Position the bracket so that the prong is close to, but does not touch, the drive belt with the clutch handle engaged.
3. Retighten the adjustment bolt.

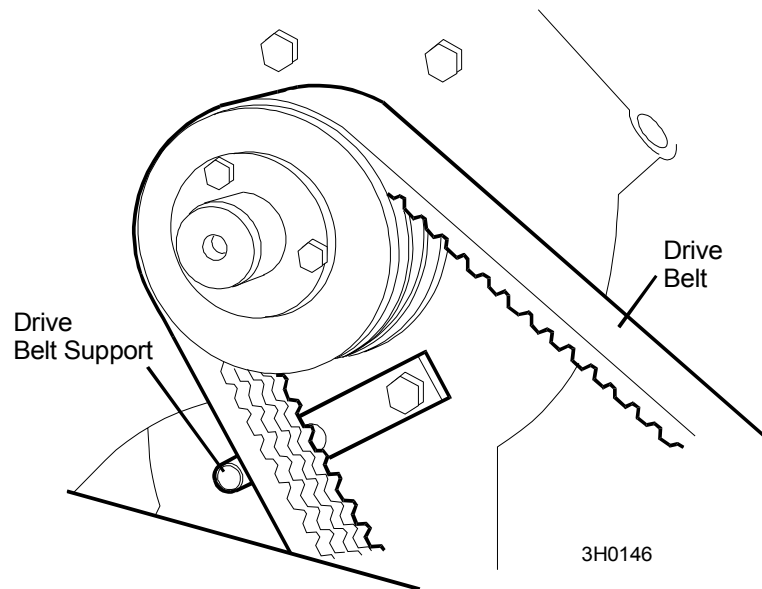

FIG. 3-6

3.8 Clutch Handle Adjustment

After the drive belts and brake strap are properly adjusted, the clutch handle should lock in the down position when the drive belts are engaged. If the clutch handle does not stay locked, adjust the handle turnbuckle.

1. Remove the blade from the sawmill.
2. Remove the inner belt guard and engage the clutch handle.
3. Hold a straight edge between the bottom and top pivot centers and measure the distance to the middle pivot.
4. Adjust the clutch handle turnbuckle until the center of the middle pivot is $7/16$ " from the straight edge.

See Figure 3-7.

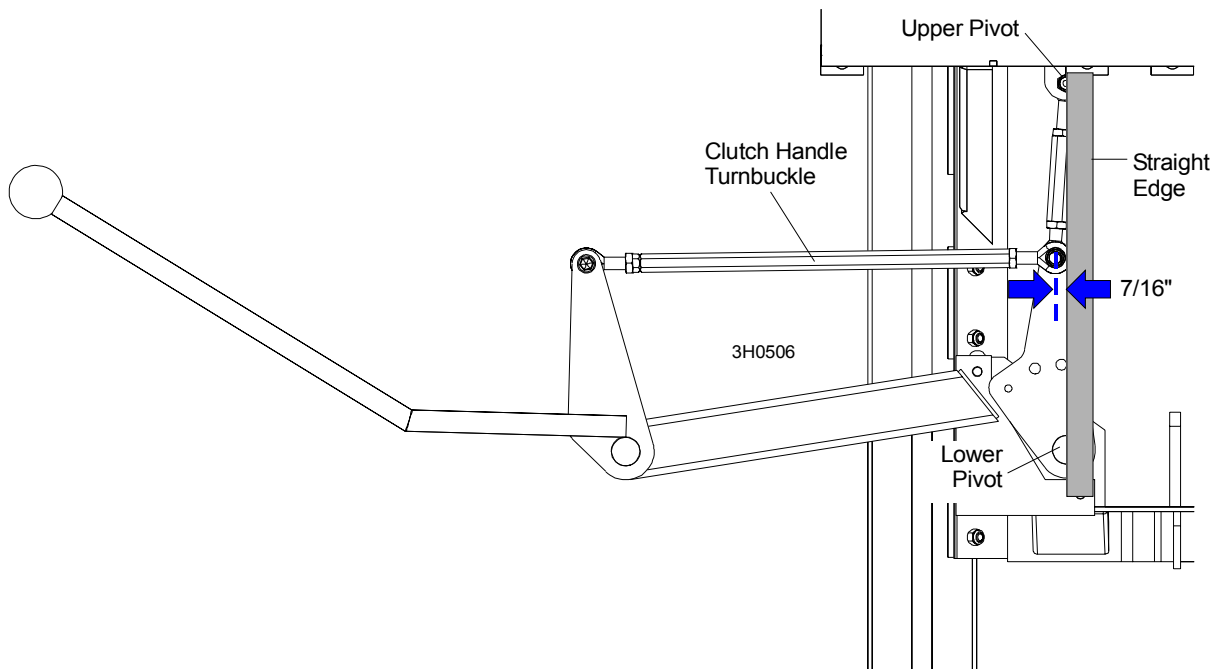







FIG. 3-7

3.9 Miscellaneous Maintenance

-  Check the valve clearance every 500 hours of operation. Adjust if necessary. See engine manual for further details.
-  Clean the fuel tank every 1000 hours of operation.
-  Clean and set the injectors every 1000 hours of operation. See engine manual for more information.
-  Replace the timing belt every 2500 hours of operation.
-  Perform a partial overhaul inspection as detailed in the engine manual every 2500 hours of operation.
-  Perform a complete overhaul inspection as detailed in the engine manual every 5000 hours of operation.

3.10 RPM Adjustments



WARNING! Remove the blade before performing any engine service. Failure to do so may result in serious injury.

200

Check the RPM with a tachometer after the first 20 hours of operation and every 200 hours thereafter.

Before checking the RPM, make sure belt and brake strap tension are correct (See Saw-mill Maintenance). Also check oil, fuel, and coolant levels.

1. Start the engine to measure the low-end RPM. Let idle for 10 minutes.
2. With the engine at idle, check the low-end RPM. Adjust to 1500. To decrease speed, loosen the idle adjustment bolt. To increase speed, tighten the idle adjustment bolt. Tighten the lock nut to hold the bolt in place.

See Figure 3-8.

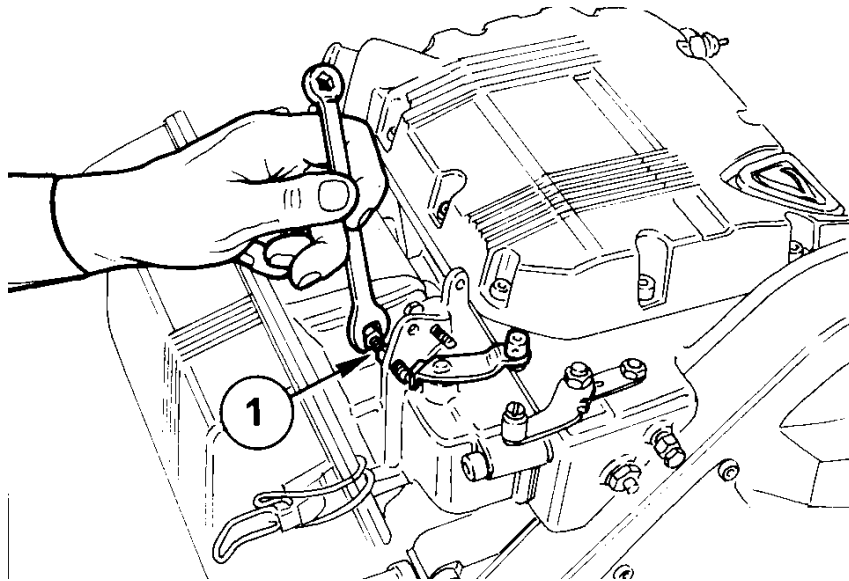

FIG. 3-8

3. Adjust the high-end RPM to 3000. To decrease speed, tighten the full speed adjustment bolt. To increase speed, loosen the full speed adjustment bolt. Tighten the lock nut to hold the bolt in place.



CAUTION! Do not adjust the high-end RPM above 3200. Doing so may cause damage to the engine.

See Figure 3-9.

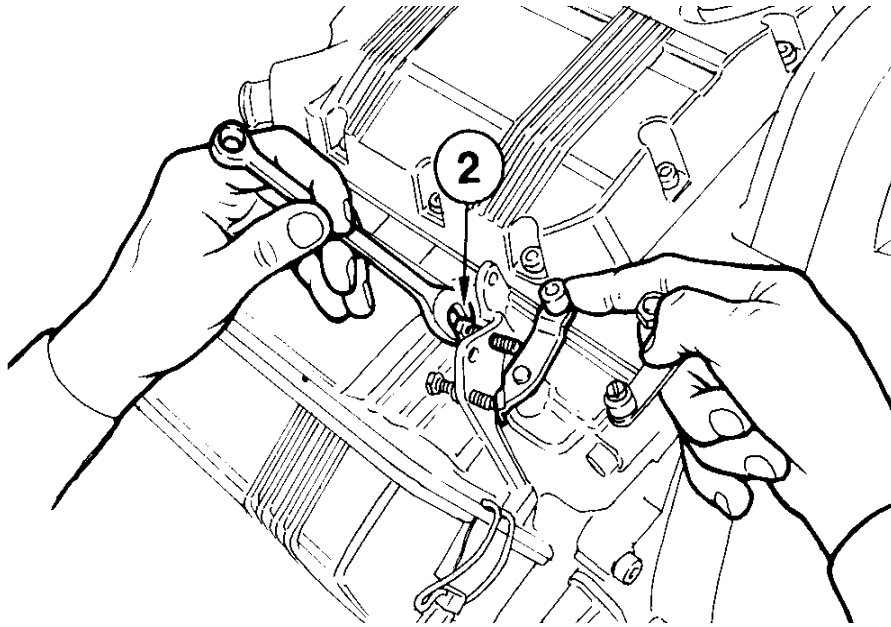

FIG. 3-9

3.11 Storage

Short Term Storage

If storing the engine over 30 days but under 6 months, take the following maintenance steps:

1. Idle the engine for 15 minutes before shutting off.
2. Drain oil and refill crankcase with protection oil MIL-1-644-P9. Run engine at 3/4 full speed for 5-10 minutes.
3. Shut off engine.
4. While the engine is still warm, drain oil. Refill crankcase with standard oil.
5. Remove the fuel filter and drain the fuel tank. Replace gasket if need and reinstall the fuel filter.
6. Carefully clean the radiator fins, heads and fan.
7. Seal all openings with tape.
8. Remove injectors. Poor a spoonful of SAE 30 oil into the cylinders. Manually rotate the cylinders to distribute the oil. Reinstall injectors.
9. Spray SAE 10W oil into exhaust and intake manifolds, rocker arm, valves, tappet, etc. Grease all unpainted parts.
10. Loosen the fan belt.
11. Wrap the engine in a plastic film.
12. Store the engine in a dry place. Keep away from soil and high voltage electric lines.

Long Term Storage

If storing over 6 months follow these additional guidelines:

1. Use a rustproof type MIL-L-21260-P10 grade 2 SAE 30 oil, such as ESSO RUST BAN 623-AGIP, RUSTIA C - SAE 30 for the lubrication and the injection system as well as for moving parts. Let the engine run with rustproof oil and drain any excess.
2. Coat the external unpainted surfaces with an antirust type MIL-C-16173D grade 3 oil, such as ESSO RUST BAN 398-AGIP, RUSTIA 100/F.
3. Replace coolant every 2 years.

Using Engine After Storage

Before using the engine after short or long term storage, perform the following steps:

1. Clean the outside of the engine.
2. Remove protections and covers.
3. Remove antirust oil with an appropriate solvent or degreaser.
4. Remove the injectors, pour a spoonful of standard oil into the cylinders and rotate manually to distribute the oil. Remove the oil pan and drain the protective oil.
5. Check the injectors, valve clearance, belt tension, head tightening, oil filter and air cleaner for proper setting. If the engine has been stored over 6 months, check bearings for corrosion.

SECTION 4 REPLACEMENT PARTS

4.1 How To Use The Parts List

- Use the table of contents or the index to locate the assembly that contains the part you need.
- Go to the appropriate section and locate the part in the illustration.
- Use the number pointing to the part to locate the correct part number and description in the table.
- Parts shown indented under another part are included with that part.
- Parts marked with a diamond (◆) are only available in the assembly listed above the part.

See the sample table below. Sample Part #A01111 includes part F02222-2 and subassembly A03333. Subassembly A03333 includes part S04444-4 and subassembly K05555. The diamond (◆) indicates that S04444-4 is not available except in subassembly A03333. Subassembly K05555 includes parts M06666 and F07777-77. The diamond (◆) indicates M06666 is not available except in subassembly K05555.

4.2 Sample Assembly				
REF	DESCRIPTION (◆ Indicates Parts Available In Assemblies Only)	PART #	QTY.	
	SAMPLE ASSEMBLY, COMPLETE (INCLUDES ALL INDENTED PARTS BELOW)	A01111	1	
1	Sample Part	F02222-2	1	
	Sample Subassembly (Includes All Indented Parts Below)	A03333	1	
2	Sample Part (◆ Indicates Part Is Only Available With A03333)	S04444-4	1	◆
	Sample Subassembly (Includes All Indented Parts Below)	K05555	1	
3	Sample Part (◆ Indicates Part Is Only Available With K05555)	M06666	2	◆
4	Sample Part	F07777-77	1	

To Order Parts:

- From the continental U.S., call **1-800-448-7881** to order parts. From Europe call our European Headquarters and Manufacturing Facility in Kolo, Poland at **+48-63-2626000**. Have your customer number, vehicle identification number, and part numbers ready when you call.
- From other international locations, contact the Wood-Mizer distributor in your area for parts.

4.3 Fuel Tank

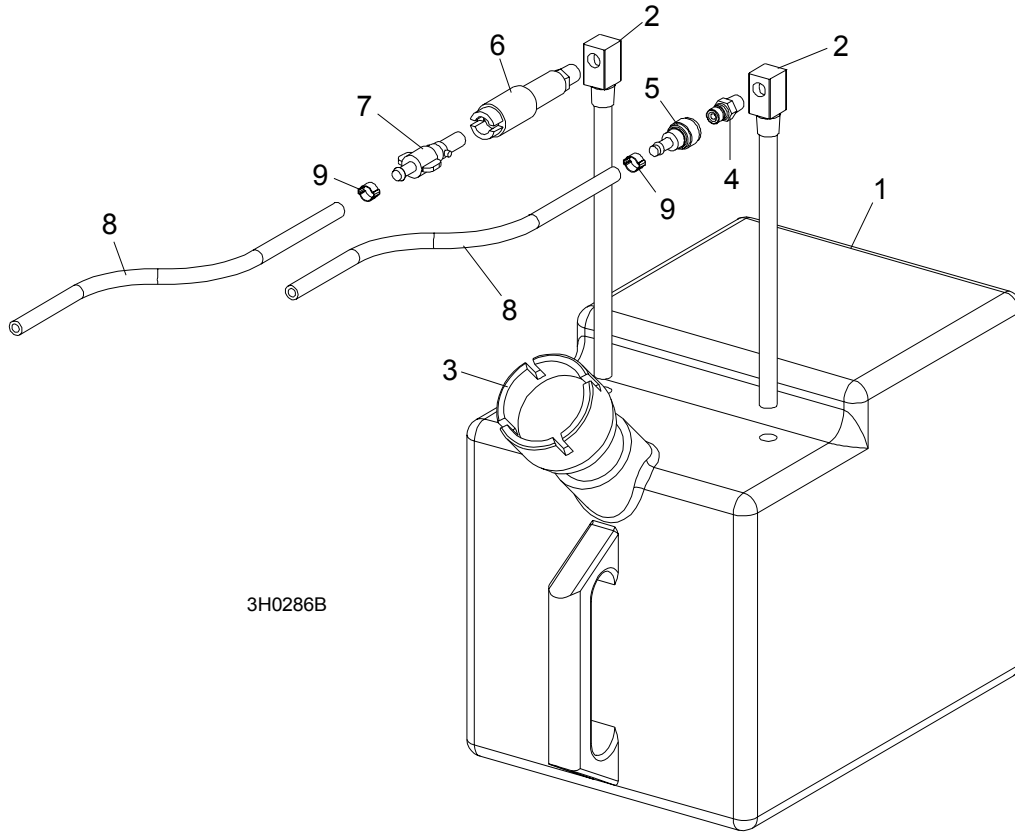

REF	DESCRIPTION (◆ Indicates Parts Available In Assemblies Only)	PART #	QTY.
	TANK ASSEMBLY, 5 GALLON GREEN DIESEL	A12132	1
1	Tank, 5 Gallon Green Fuel	P12166	1
2	Pickup, 9" Fuel	P12172	2
3	Cap, 3/5 Gallon Fuel Tank	P09683	1
4	Fitting, 1/4" NPT Male Quick Disconnect	015583	1
5	Fitting, Female Quick Disconnect Barb	015582	1
6	Fitting, 1/4" NPT Plastic Female Disconnect	P12175	1
7	Fitting, 1/4" Barb Plastic Male Disconnect	P12176	1
8	HOSE, 1/4" ID FUEL	P642	4.7 m
9	CLAMP, 7/32 - 1/2 HOSE	F81080-1	6

4

Replacement Parts Engine Mount Assembly

4.4 Engine Mount Assembly

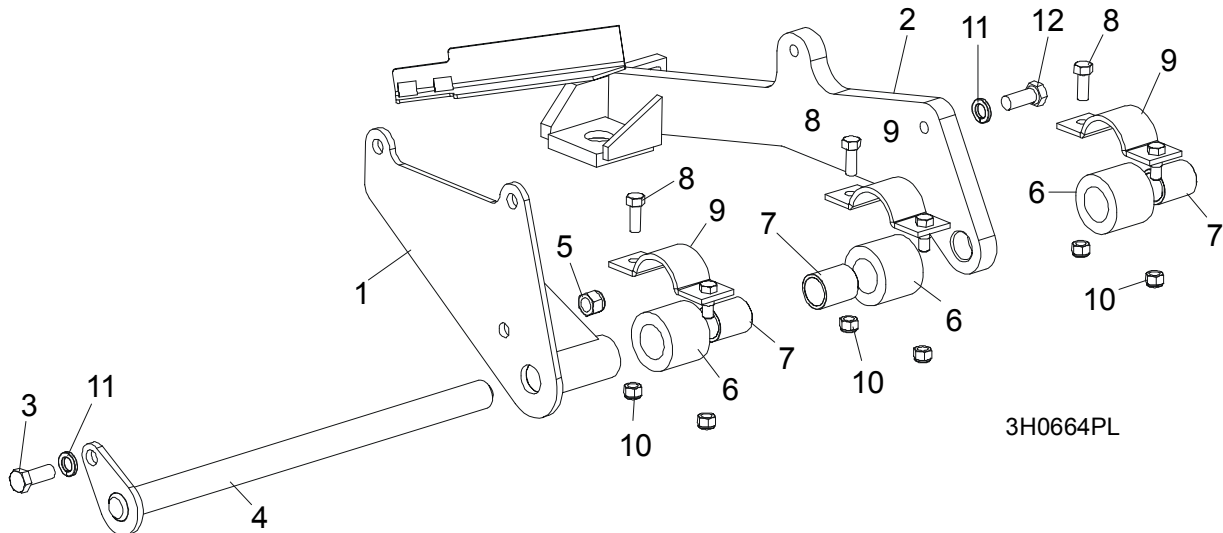

REF	DESCRIPTION (◆ Indicates Parts Available In Assemblies Only)	PART #	QTY.	
1	MOUNT, FRONT MOTOR	093199-1	1	
2	MOUNT WELDMENT, DIESEL MOTOR	086802-1	1	
3	BOLT, M12 X 30-8.8 HEX HEAD	F81004-22	1	
4	PIN WELDMENT, MOTOR PIVOT	014056	1	
5	NUT, M12-8 HEX NYLON LOCK	F81034-2	1	
	BUSHING, RUBBER ASSEMBLY	016380	3	
6	Bushing, Motor Mount Rubber	016378	1	
7	Bushing, Clutch/Brake Lever	016379	1	
8	BOLT, M10 X 25-8.8 HEX HEAD	F81003-11	3	
9	CLAMP WELDMENT, MOTOR MOUNT	086200	3	
10	NUT, M10-8 HEX NYLON LOCK	F81033-1	6	
11	WASHER, 13 SPLIT LOCK	F81056-1	2	
12	BOLT, M12 X 30-8.8 HEX HEAD	F81004-22	1	

4.5 Engine Assembly

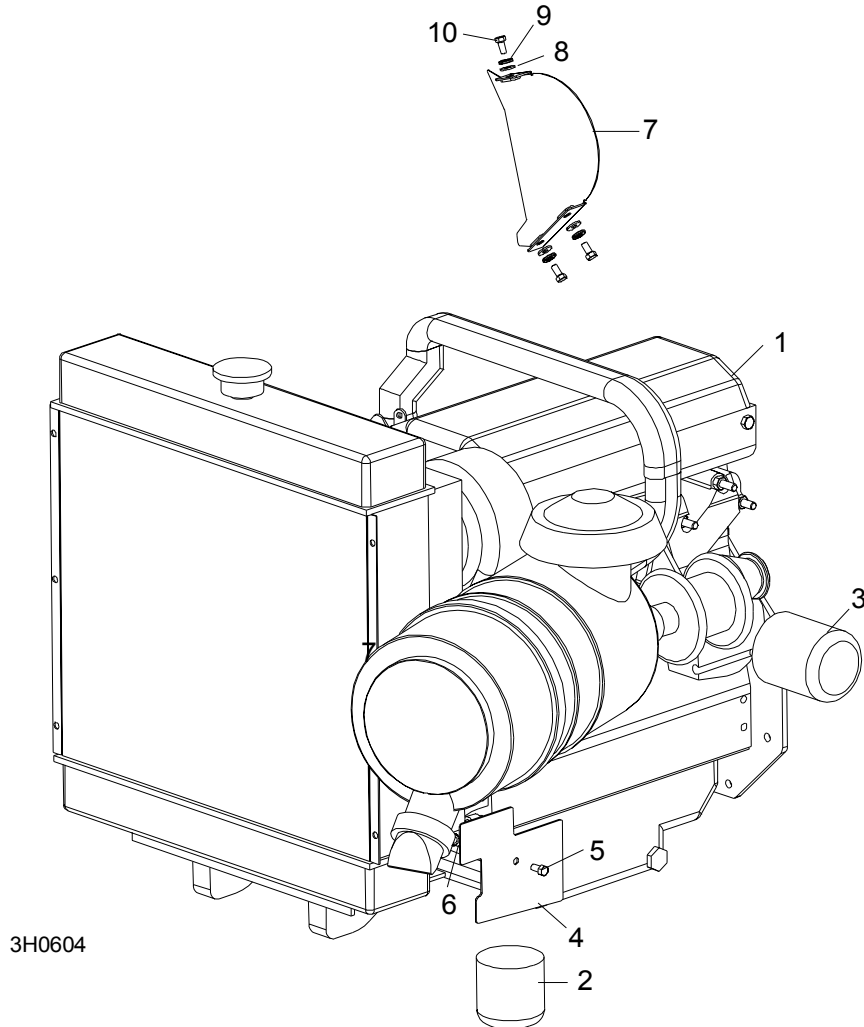

REF	DESCRIPTION (◆ Indicates Parts Available In Assemblies Only)	PART #	QTY.	
1	ENGINE, 38HP LOMBARDINI DIESEL	088262	1	◆
	Cap, Oil Fill	014294	1	
2	Filter, Diesel Fuel	014209	1	
3	Filter, Diesel Oil	014211	1	
	Fuse Link, 80 Amp Glow Plug	014350	1	
	Gasket Kit, Lombardini Engine	014293	1	
	Plug, Diesel Glow	014278	1	
	Pump, Lombardini Fuel	014289	1	
	Pump, Lombardini Water	014288	1	
	Starter, Lombardini Diesel Engine	014286	1	
	Thermostat, Lombardini Engine	014296	1	
	Valve, Fuel	014279	1	
	Guard, Lombardini Fan Left #6927-346	014747	1	
	Guard, Lombardini Fan Right #6927-350	014748	1	

4 Replacement Parts

Engine Assembly

	Rail Kit, Lombardini Replacement Fuel	016073	1	
4	PLATE, LOMBARDINI DUST SHIELD	014400	1	
5	BOLT, 1/4-20 X 1/2" HEX HEAD	F05005-15	1	
6	NUT, 1/4-20 SELF-LOCKING	F05010-9	1	
7	GUARD WELDMENT, D40 IDLER	016065	1	
8	WASHER, 7,4 FLAT	F81056-11	3	
9	WASHER, Z 6,1 SPLIT LOCK	F81053-3	3	
10	BOLT, 1/4-20 X 1/2" HEX HEAD	F05005-15	3	
	HARNES ASSEMBLY, LOMBARDINI DIESEL ENGINE	024452	1	
	Breaker Assembly, Water Temp Max Circuit	024453	1	
	BELT, LOMBARDINI IDLER	016071	1	
	BELT, 3BX73	091548	1	
	HEATER, OPTIONAL ENGINE WATER (NOT SHOWN)	014635	1	
	KIT, LOMBARDINI HEAD GASKET	016178	1	

4.6 Primary Fuel Filter

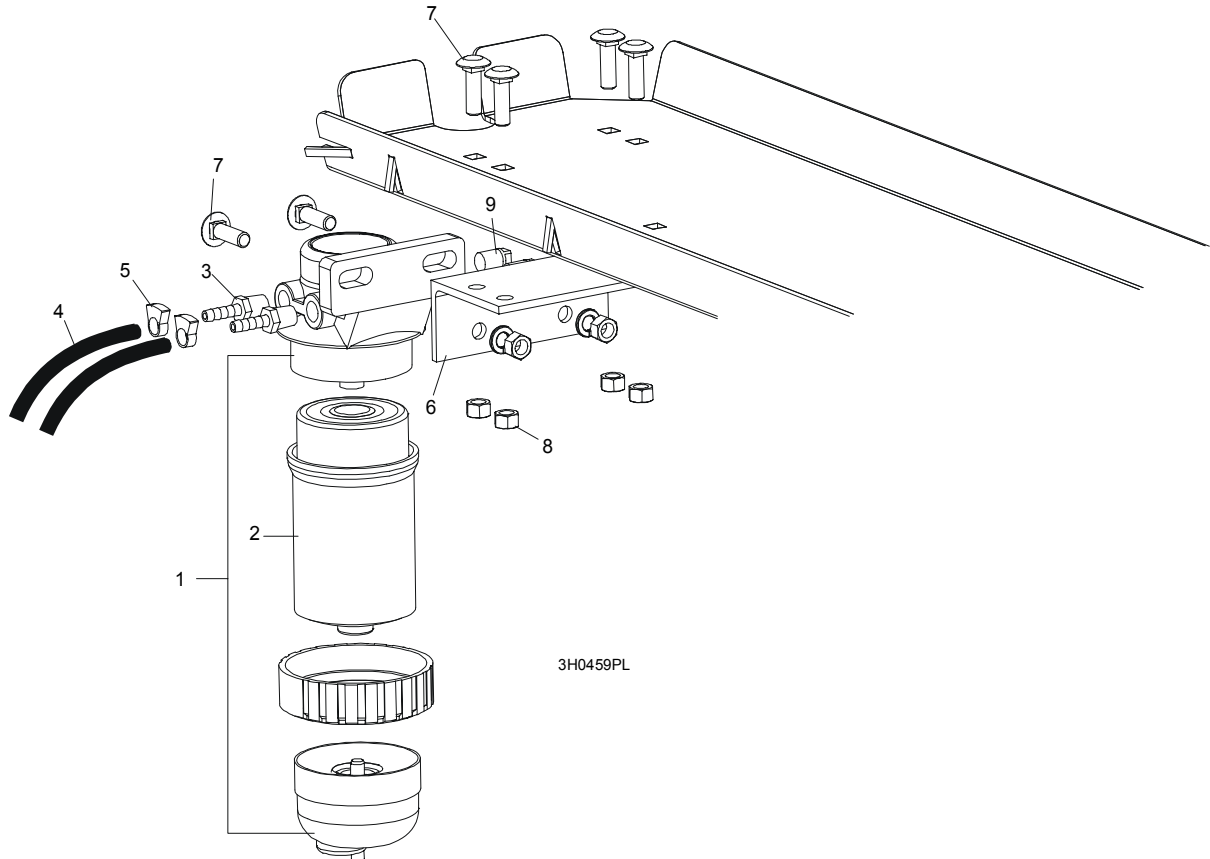

REF	DESCRIPTION (◆ Indicates Parts Available In Assemblies Only)	PART #	QTY.	
	FILTER KIT, PRIMARY DIESEL FUEL	015906	1	
1	Filter Assembly, Standadyne Fuel #33816	015897	1	
2	Filter, Standadyne Fuel Cartridge #31865	015898	1	
3	Fitting, 1/4" NPT to 1/4" Hose Barb	P05393	2	
4	Hose, 1/4" ID Fuel	P642	2.1 m	
5	Clamp, 7/32 - 1/2 Hose	F81080-1	2	
6	Bracket, Diesel Fuel Filter Mount	086086-1	1	
7	Bolt, 3/8-16 x 1 1/4" Carriage Head	F05007-11	6	
8	Nut, 3/8-16 Hex	F05010-10	6	
9	Fitting, 1/4" NPT Plug	P05498	2	

4 Replacement Parts

Alternator Assembly

4.7 Alternator Assembly

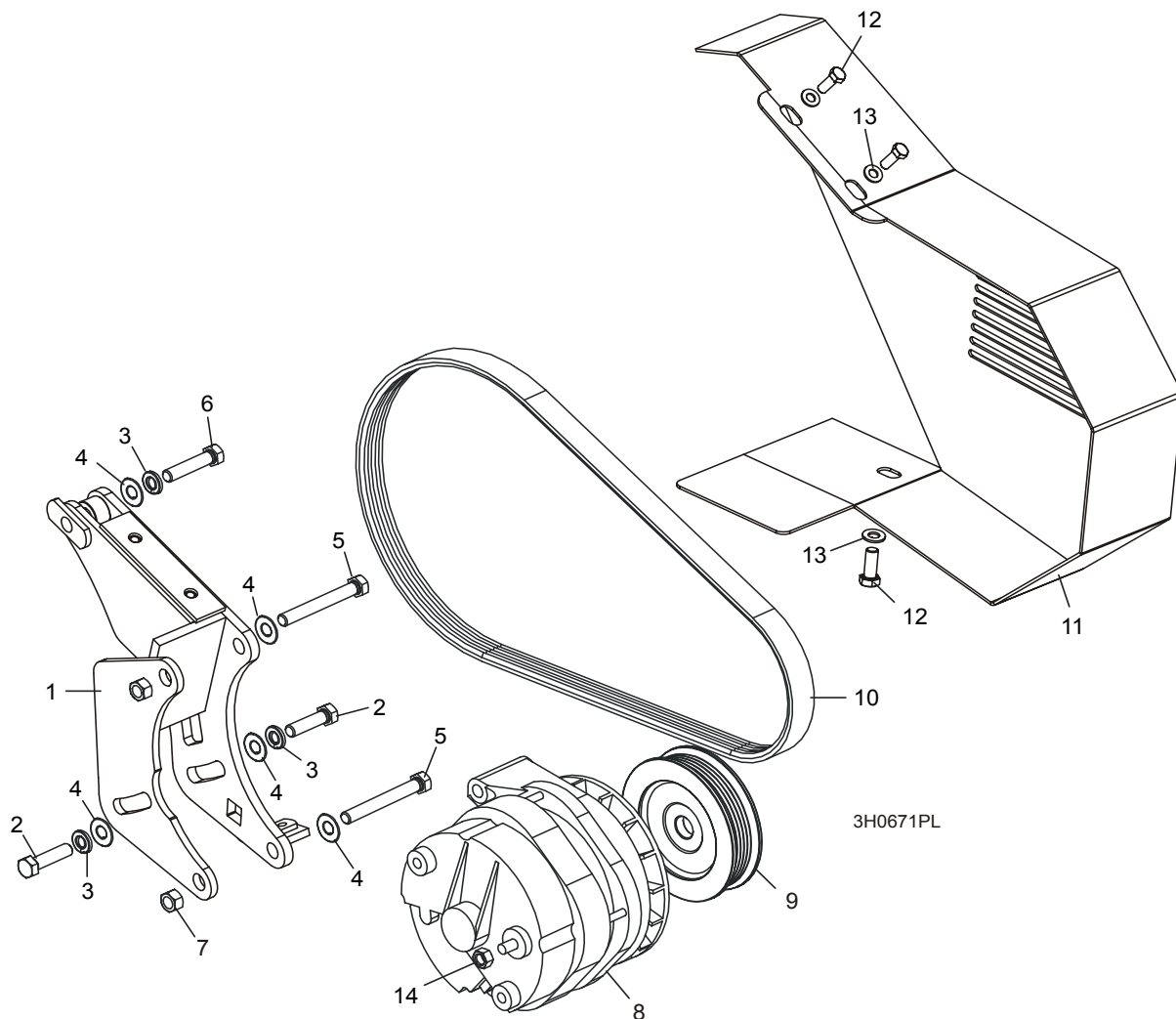

REF	DESCRIPTION (◆ Indicates Parts Available In Assemblies Only)	PART #	QTY.	
	WIRE ASSEMBLY, 61/140 AMP ALTERNATOR PLUG	015969	1	
	ALTERNATOR KIT, 140 AMP D40	023803	1	
	Belt Guard Parts (See Section 4.16)			
1	Bracket Weldment, Alternator Mounting	087215-1	1	
2	Bolt, 3/8-16 x 3/4 Hex Head Full Thread	F05007-27	2	
3	Washer, 10.2 Split Lock	F81055-2	3	
4	Washer, 10.5 Flat	F81055-1	5	
5	Bolt, M10 X 75-8.8 Hex Head	F81003-15	2	
6	Bolt, 3/8-16 x 1 1/2" Hex Head	F05007-3	1	
7	Nut, M10-8 Nylon Lock	F81033-1	3	
	Block, Alternator Mount	015331	1	
	Alternator Assembly, 140 Amp	023730	1	
8	Alternator, 140 Amp	023695	1	◆

9	Pulley, 140 Amp Alternator	023694	1	
10	Belt, 6PK1090 Fiberglass	087304	1	
11	Guard Weldment, 140 Amp Alternator Belt	087194-1	1	
12	Bolt, M6 x 12-8.8 Hex Head	F81001-7	3	
13	Washer, 6.5 Flat	F81053-11	3	
14	NUT, M8 X 1.25 HEX JAM	F81032-5	1	

4

Replacement Parts Relay/Throttle Assembly

4.8 Relay/Throttle Assembly

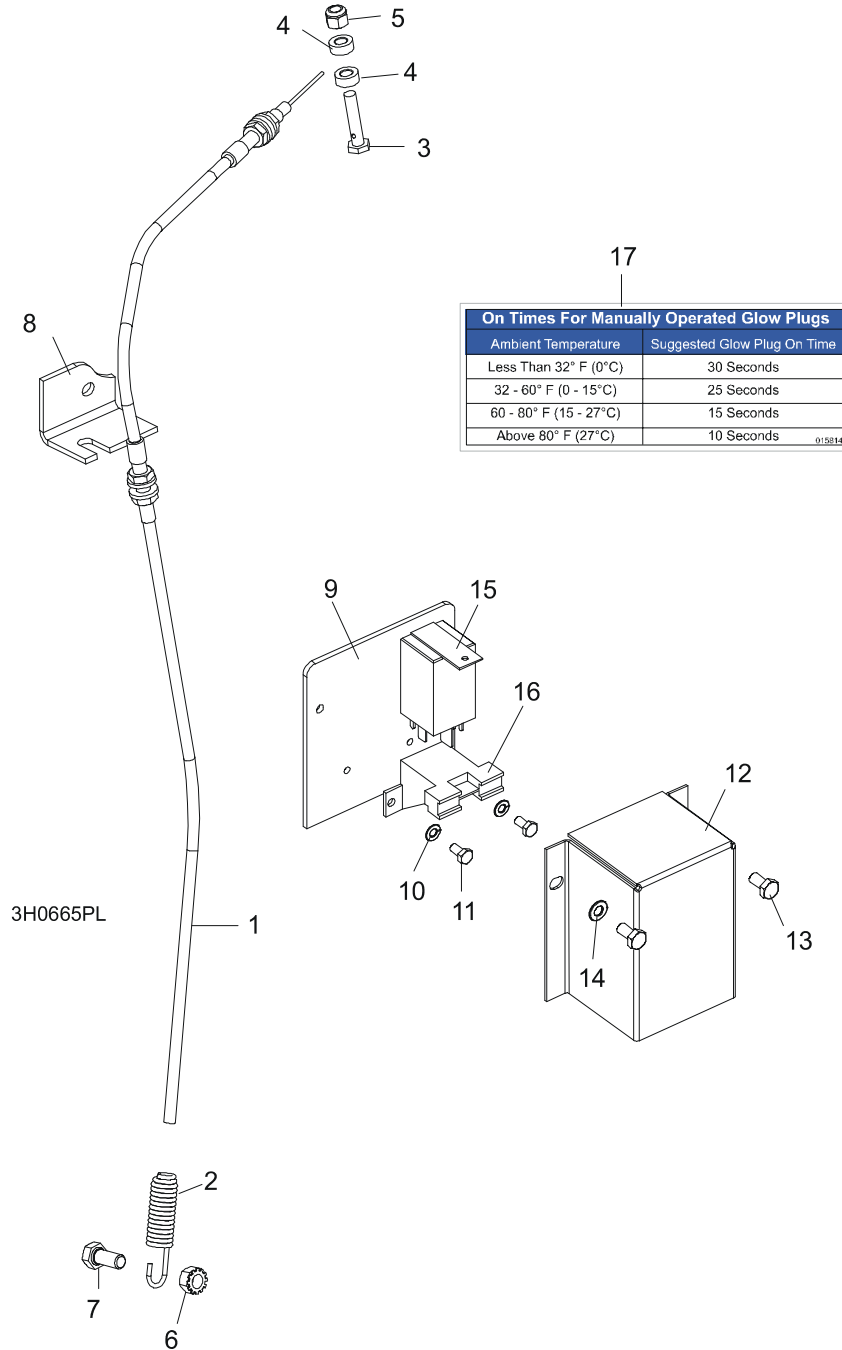

REF	DESCRIPTION (◆ Indicates Parts Available In Assemblies Only)	PART #	QTY.
1	CABLE, D30/D40 .078" THROTTLE	089480	1
2	SPRING, THROTTLE	016033	1
3	BOLT, D30/D40 THROTTLE CABLE	015985	1
4	WASHER, .266 X .50 X .28" AL-BRONZE	015986	2
5	NUT, 1/4-20 NYLON LOCK	F05010-69	1
6	NUT, M8-8 SELF-LOCKING HEX	F81032-1	1

7	BOLT, M8 X 20-8.8 HEX HEAD	F81002-4	1	
8	BRACKET, THROTTLE CABLE MOUNT	015566	1	
9	PLATE WELDMENT, DIESEL RELAY BOX MOUNT	086236-1	1	
10	WASHER, 5.3 SPLIT LOCK	F81052-1	2	
11	BOLT, M5 X 12-5.8 HEX HEAD	F81000-5	2	
12	BOX, D40 GLOW PLUG RELAY	014199	1	
13	BOLT, M6 X 12-8.8 HEX HEAD	F81001-7	2	
14	WASHER, 6.4 FLAT	F81053-1	2	
15	RELAY, GLOW PLUG	023359	1	
16	SOCKET, GLOW PLUG RELAY + TERMINAL KIT	023358	1	
	TERMINAL, 1/4" QUICK 14-16GA FI	F05708-3	5	
	FLAG TERMINAL 12GA FI	F05708-4	1	
17	DECAL, LOMBARDINI GLOW PLUG ON TIME (LOCATED ON CONTROL BOX)	015814	1	

4

Replacement Parts

Muffler Assembly

4.9 Muffler Assembly

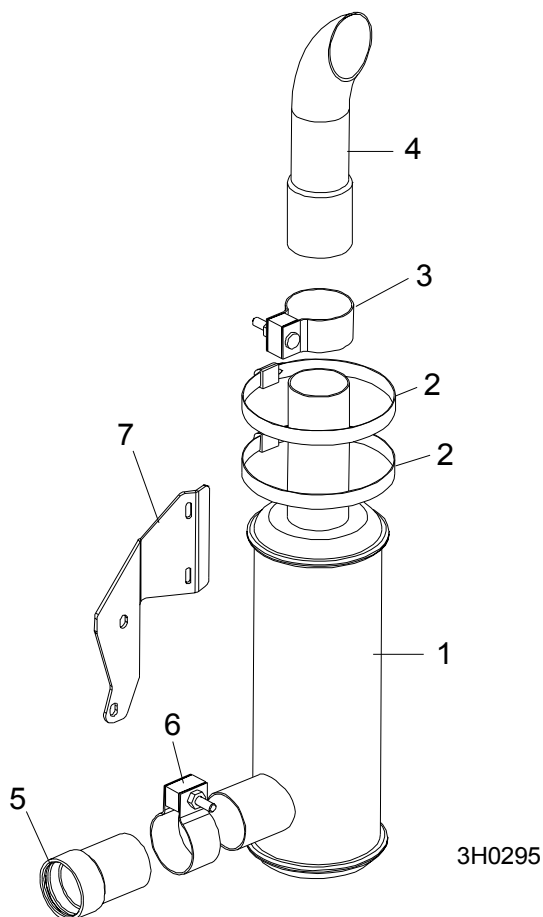

REF	DESCRIPTION (◆ Indicates Parts Available In Assemblies Only)	PART #	QTY.
1	MUFFLER, DIESEL	014093	1
2	CLAMP, 5" WORM	014096	2
3	CLAMP, MUFFLER	014095	1
4	STACK, DIESEL MUFFLER	014094	1
5	TUBE, LOMBARDINI EXHAUST	014319	1
6	CLAMP, MUFFLER 2" NELSON 90869A	014205	1
7	BRACKET, MUFFLER	014321	1

4.10 Drive Assembly

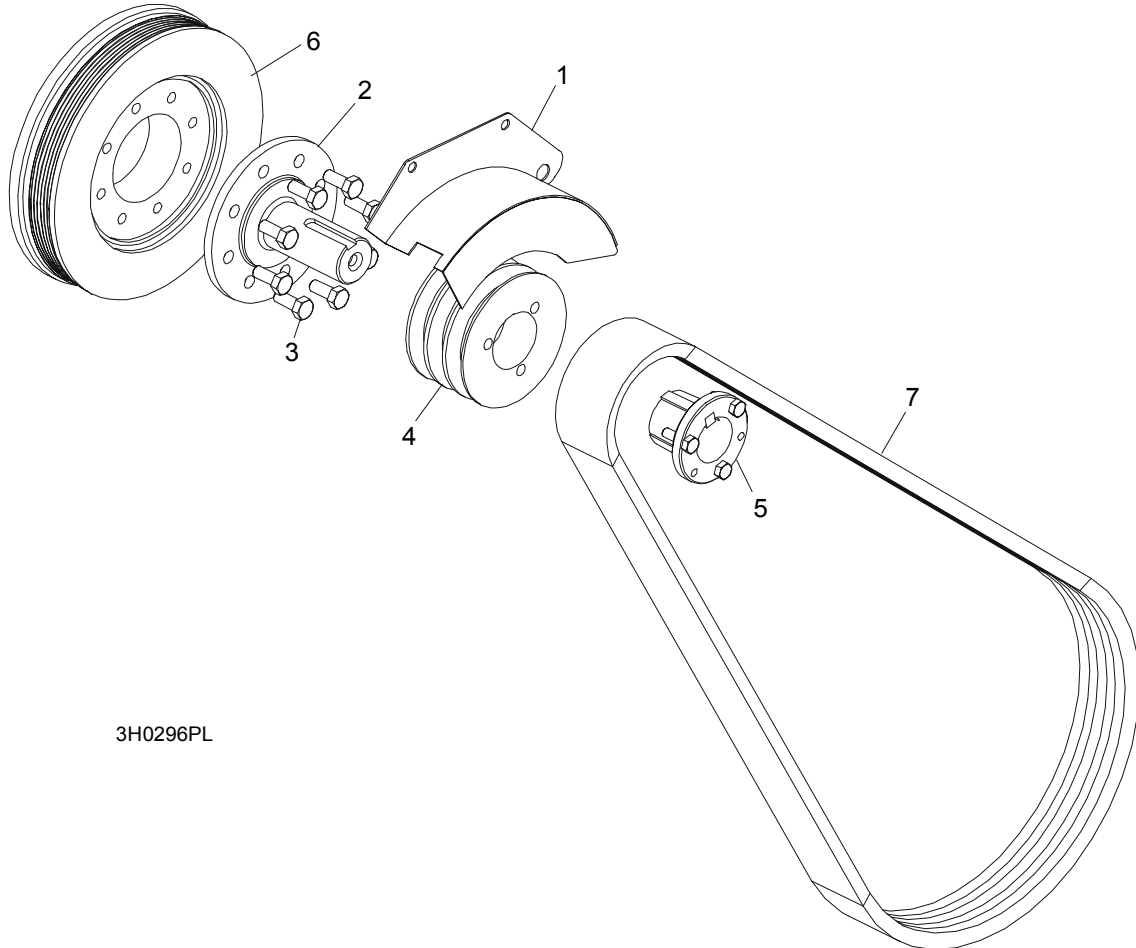

3H0296PL

REF	DESCRIPTION (◆ Indicates Parts Available In Assemblies Only)	PART #	QTY.
1	COVER WELDMENT, FLYWHEEL	086785	1
2	SHAFT, OUTPUT	086329	1
3	BOLT, M10X25 GRADE 10.9 HEX HEAD	F05009-52	8
4	SHEAVE, 3TB42 MOTOR DRIVE	014007	1
5	BUSHING, SPLIT TAPER, P1 1 9/16"	014003	1
6	FLYWHEEL, ALTERNATOR BELT	015309	1
7	BELT, 3BX73	091548	1
	SUPPORT, D30/D40/E25 DRIVE BELT UPPER	085865-1	1
	SUPPORT, D30/D40/E25 DRIVE BELT LOWER	085922-1	1

4 Replacement Parts

Radiator Assembly

4.11 Radiator Assembly

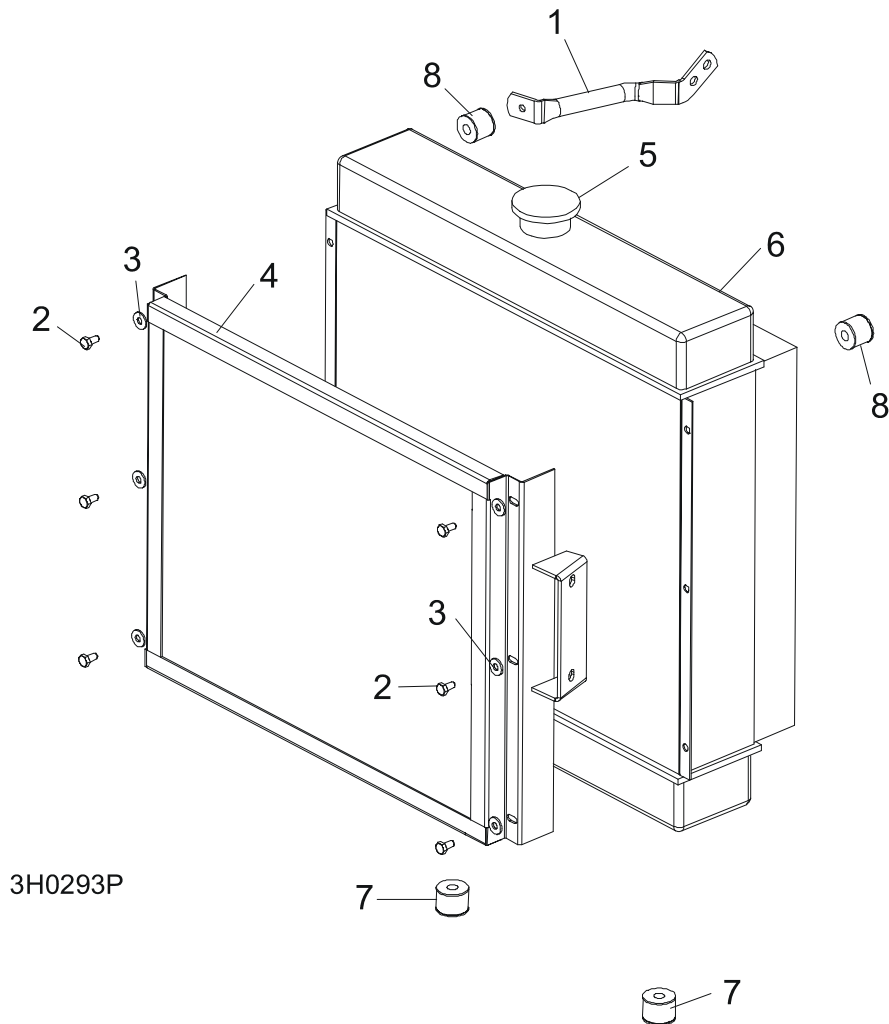

3H0293P

REF	DESCRIPTION (◆ Indicates Parts Available In Assemblies Only)	PART #	QTY.
1	BRACE, LOMBARDINI RADIATOR LEFT SUPPORT 9265-162	016171	1
2	SCREW, M6 X 12-8.8 HEX HEAD CAP FULL THREAD	F81001-7	6
3	WASHER, 7.4 FLAT	F81056-11	6
4	GRILL, RADIATOR	087071-1	1
5	CAP, RADIATOR FILL	014295	1
6	RADIATOR, LOMBARDINI	014291	1
7	BUSHING, RADIATOR VIBRATION LOWER	016143	2
8	BUSHING, RADIATOR VIBRATION UPPER	016144	2

4.12 Engine/Muffler Guards

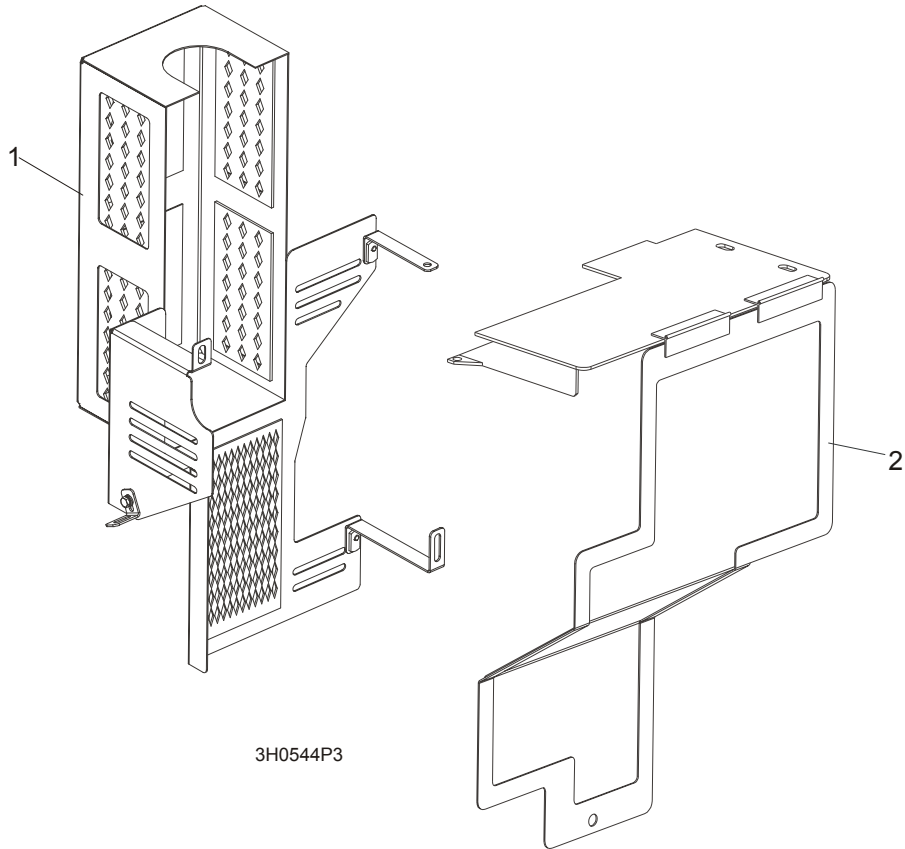

REF	DESCRIPTION (◆ Indicates Parts Available In Assemblies Only)	PART #	QTY.	
1	GUARD, D38 RIGHT SIDE	093779	1	
2	GUARD, D38/D40 SIDE ENGINE	085852-1	1	

4 Replacement Parts

Engine Pulley Guards

4.13 Engine Pulley Guards

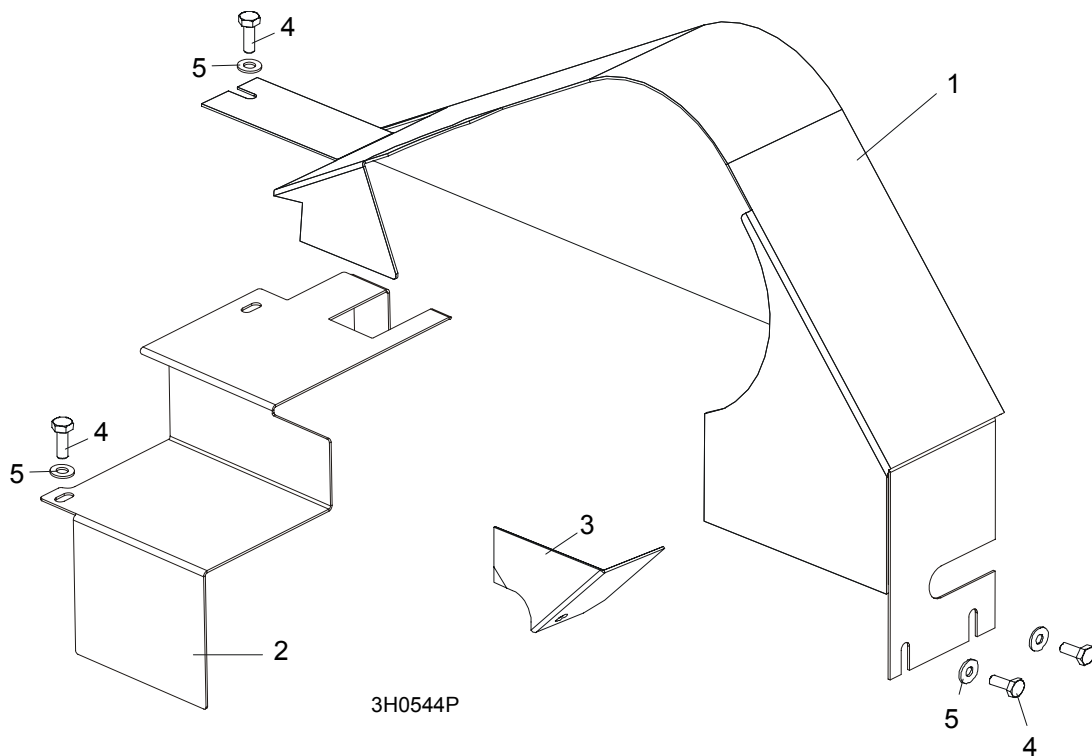

REF	DESCRIPTION (◆ Indicates Parts Available In Assemblies Only)	PART #	QTY.	
1	GUARD WELDMENT, D40 ENGINE PULLEY	086043-1	1	
2	GUARD, D40 SIDE ENGINE PULLEY	086403-1	1	
3	GUARD, D40 BOTTOM ENGINE PULLEY	015158	1	
4	WASHER, 6.5 FLAT	F81053-11	3	
5	BOLT, M6 X 20-8.8 HEX HEAD	F81001-2	3	

4.14 Air Cleaner Assembly

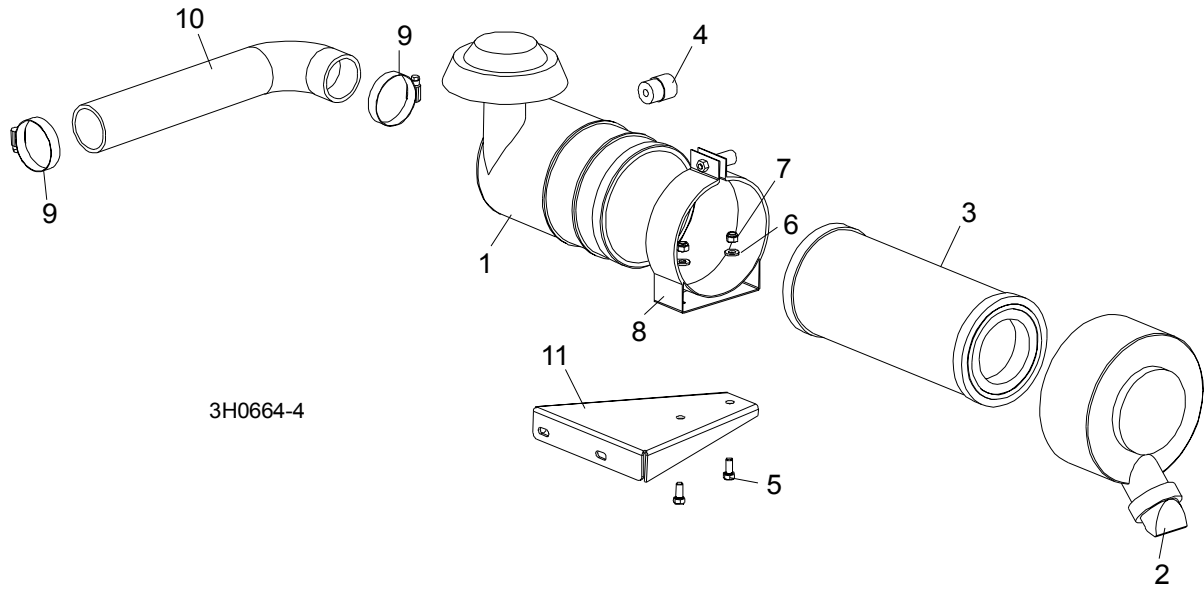

REF	DESCRIPTION (◆ Indicates Parts Available In Assemblies Only)	PART #	QTY.
1	CLEANER ASSEMBLY, DONALDSON AIR COMPLETE	N/A	1
2	Boot, Air Cleaner Evacuator	014287	1
3	Element, Donaldson Air Filter	014763	1
4	INDICATOR, AIR CLEANER RESTRICTION	014336	1
5	BOLT, M8X20MM, HEX HEAD,GR 5.8 ZINC	F81002-4	2
6	WASHER, M8, FLAT,ZINC	F81054-1	2
7	NUT, M8,HEXAGON,NYLON LOCK ZINC	F81032-2	2
8	CLAMP, 5 1/2" SPRING	015453	1
9	CLAMP, 2 1/2" HOSE	P09895	1
10	TUBE, D30 AIR INTAKE	015452	1
11	BRACKET, AIR CLEANER MOUNT	015450	1



Electrical Information

Electrical Symbol Diagram, Super D38

SECTION 5 ELECTRICAL INFORMATION

5.1 Electrical Symbol Diagram, Super D38

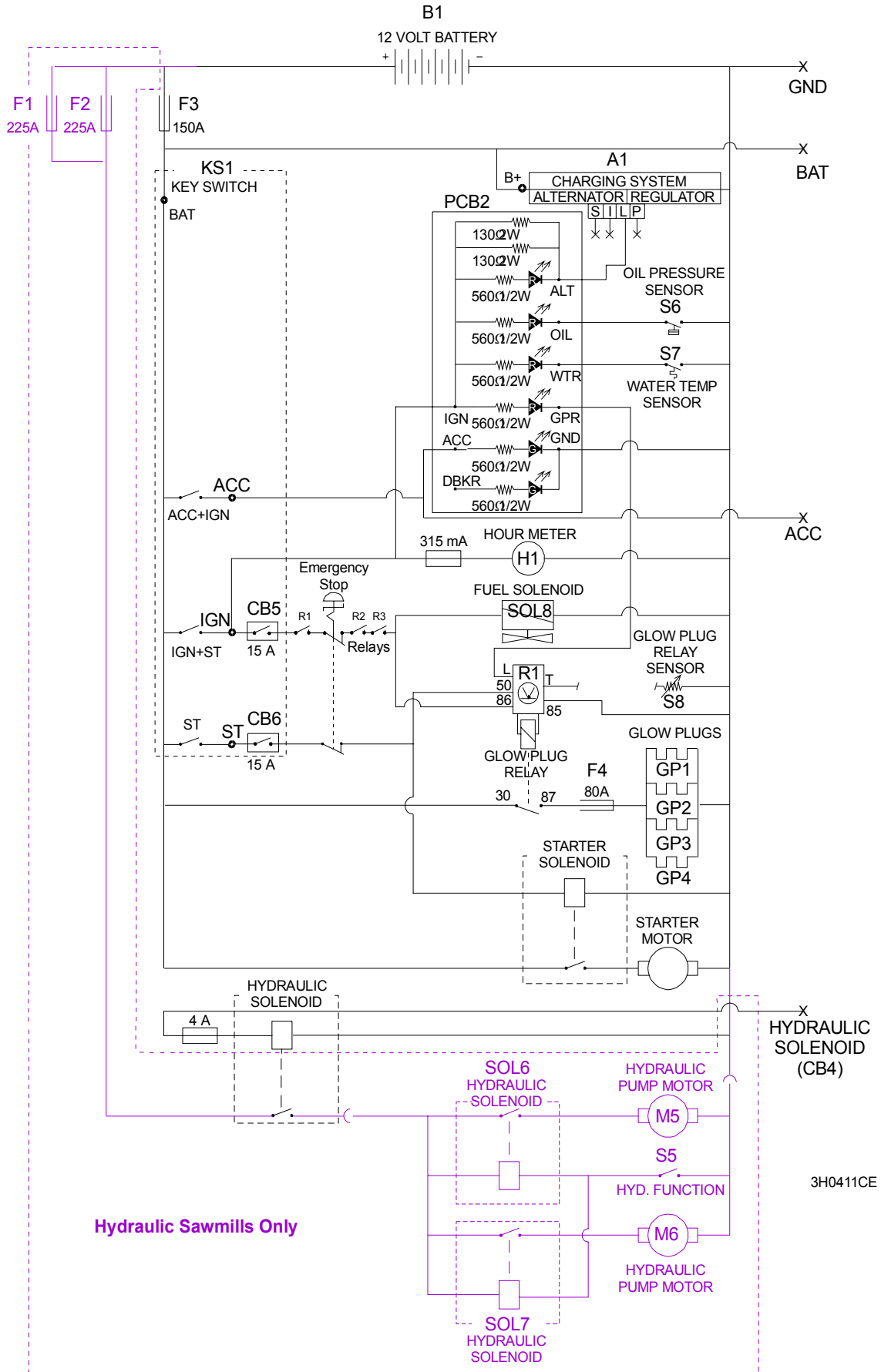
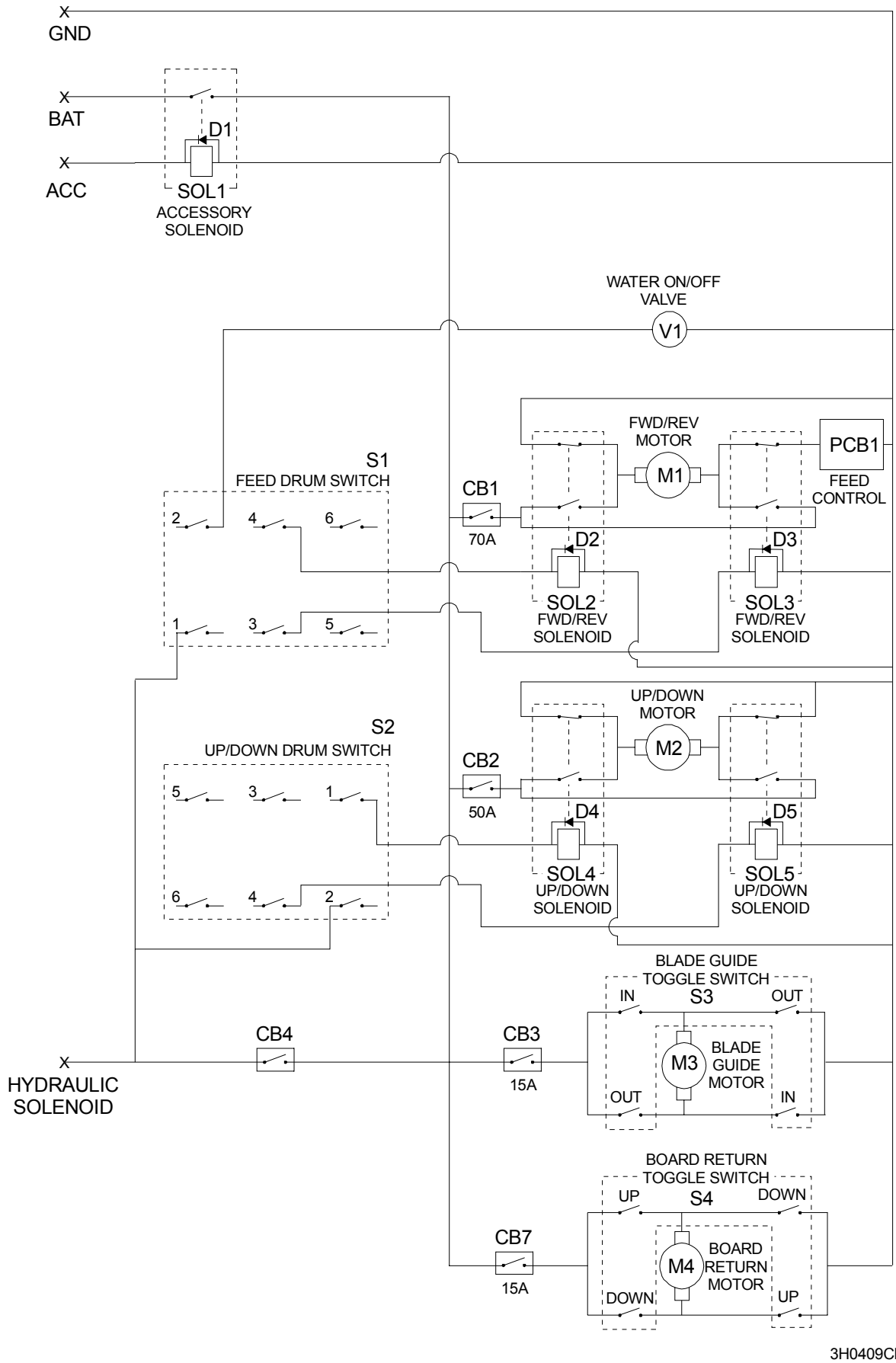

FIG. 5-1 D40 SYMBOL DIAGRAM (PAGE 1 OF 2).



3H0409CE

FIG. 5-2 D40 SYMBOL DIAGRAM (PAGE 1 OF 2).

5.2 Electrical Components, Super D38

Item	Mfg. Part No.	Mfg.	Wood-Mizer Part No.	Description
A1	10480168	Delco-Remy	015473	Alternator, 140 Amp
B1	95751	BANNER	088323	Battery, 12 Volt (See Section 5.3)
CB1	70-1648-009	Mech. Prod.	015527	Breaker, 70 Amp Manual Reset Panel Mount, Power Feed
CB2	1648-009-050-006	Mech. Prod.	021256	Breaker, 50 Amp Manual Reset Panel Mount, Up/Down
CB3	CH30407-15	Cole-Hersee	E20430	Breaker, 15 Amp Manual Reset, Blade Guide
CB4	CH30407-15	Cole-Hersee	E20430	Breaker, 15 Amp Manual Reset, Accessory
CB5	CH30407-15	Cole-Hersee	E20430	Breaker, 15 Amp Manual Reset, Ignition
CB6	CH30407-15	Cole-Hersee	E20430	Breaker, 15 Amp Manual Reset, Start
CB7	CH30407-15	Cole-Hersee	E20430	Breaker, 15 Amp Manual Reset, Board Return
CB10	024453	Wood-Mizer	024453	Breaker Assy, Water Temp Max Circuit
D7	024123	Wood-Mizer	024123	Diode Assembly, Inductive Kick Protection
F1, F2 ¹	RL-225	Gould	P11550	Fuse Link, 225 Amp, 250 Volt For Hydraulic + 12 Volt Circuit
F3	RL-150	Gould	023361	Fuse Link, 150A 250V For Main + 12 Volt Starter, Alternator
F4	4062-232	Lombardini	014350	Fuse Link, 80 Amp Lombardini Glow Plug
GP1-GP4	2100-072	Lombardini	014278	Glow Plug
H1	T14BH517BC9	ENM Corp.	015401	Hour Meter, 12 Volt, Low Power T14 Series
KS1	121801	General	P04350	Key Switch, 4-position (Accessory, Off, Ignition, Start)
M1	108677.00	Leeson	024169	Motor, 3/4HP 12VDC TEFC Power Feed w/o Base
M2	108678.00	Leeson	015174	Motor, 3/4HP 12VDC TEFC Up/Down w/Base
M3	P09698-1	Klauber	A10365	Motor, 12 Volt Blade Guide Arm 53:1 Gear
M4	P09698-1	Klauber	A10365	Motor, 12 Volt Board Return 53:1 Gear
M5, M6 ¹	8111	Monarch	P09955	Motor, 12 Volt Hydraulic Pump
PCB1	024412	Wood-Mizer	024412	Circuit Board, Control Box Power Feed
PCB2	089694	Wood-Mizer	089694	Board, LED Circuit (Diesel)
R1	2193-084	Lombardini	023359	Relay, Glow Plug Timer
S1	2601-AF2-S11	Square D	E20438	Drum Switch, Power Feed Fwd/Reverse Motor
S2	2601-AF2-S12	Square D	E20440	Drum Switch, Up/Down Motor
S3	34-591Q	Pollak	024200	Toggle Switch, Blade Guide In/Out Motor
S4	34-591Q	Pollak	024200	Toggle Switch, Board Return Motor
S5 ¹	024198	Wood-Mizer	024198	Switch, Hydraulic Pump Levers
S6	--	--	014557	Switch Kit, Oil Pressure Sending
	6745-044	Lombardini	014290	Switch, Oil Pressure Sending
	4670-060	Lombardini	014554	Gasket, Copper Oil Pressure
S7	--	--	014558	Switch Kit, Water Temperature Sending
	9195-077	Lombardini	014351	Switch, Water Temperature Sending
	4670-019	Lombardini	014555	Gasket, Copper Water Temperature

TABLE 5-1

5 Electrical Information

Electrical Components, Super D38

S8 ²	--	--	014559	Switch Kit, Glow Plug Temperature Sending
	9195-067	Lombardini	014352	Switch, Glow Plug Temperature Sending
	4670-061	Lombardini	014556	Gasket, Copper Glow Plug Temperature
SOL1	120-943	Stancor	P10449	Solenoid, Accessory Circuit
SOL2-SOL5	586-911	Stancor	015417	Solenoid, 200A 12V DPST
SOL6,SOL7, SOL10 ¹	586-902	Stancor	015470	Solenoid, 200A 12V SPST Hydraulic Pump Motor
SOL8	3587-119	Lombardini	014279	Solenoid, Fuel
V1	S24C-6V12VDC	Atkomatic	014165	Valve, Waterlube Solenoid
VR1	015408	Wood-Mizer	024450-1	Potentiometer, Variable Resistance Power Feed

TABLE 5-1

¹ Component applies to hydraulic models only.

² Glow plug sensing relay disconnected to provide manual control of glow plug operation. [See Section 2.1](#) for manual glow plug on time recommendations.

5.3 Battery Specifications, Super D38

Group No.	Type No.	Performance Level		Approx. Weight (Wet)	Maximum Overall Dimensions		
		Cranking Performance	Reserve Capacity		Length	Width	Height
31	1231PMF	1100	195	60 lb. (27.2 Kg)	13" (330 mm)	6 3/4" (171 mm)	9 1/2" (241 mm)

TABLE 5-2

5.4 Electrical Wiring Diagram, D38

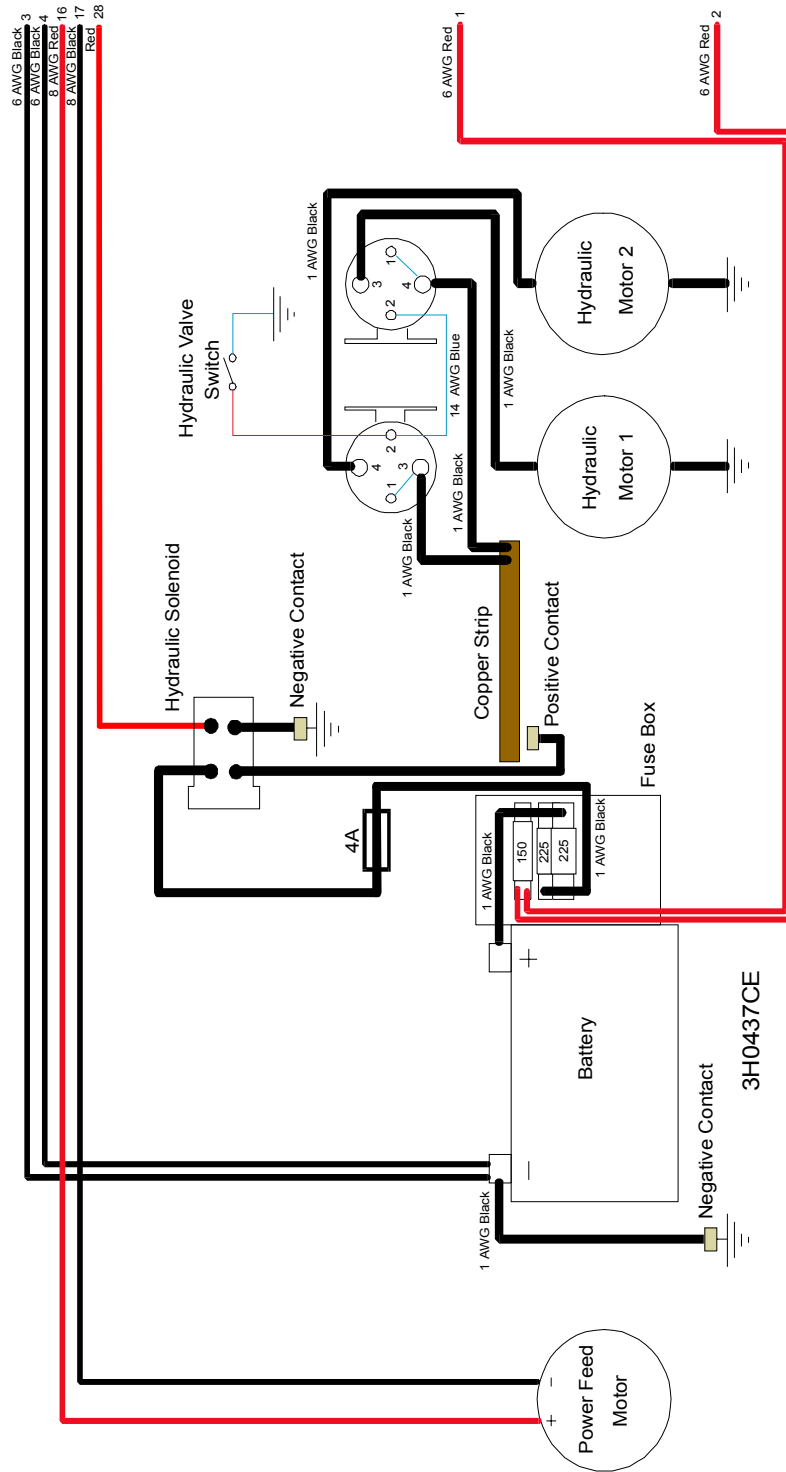
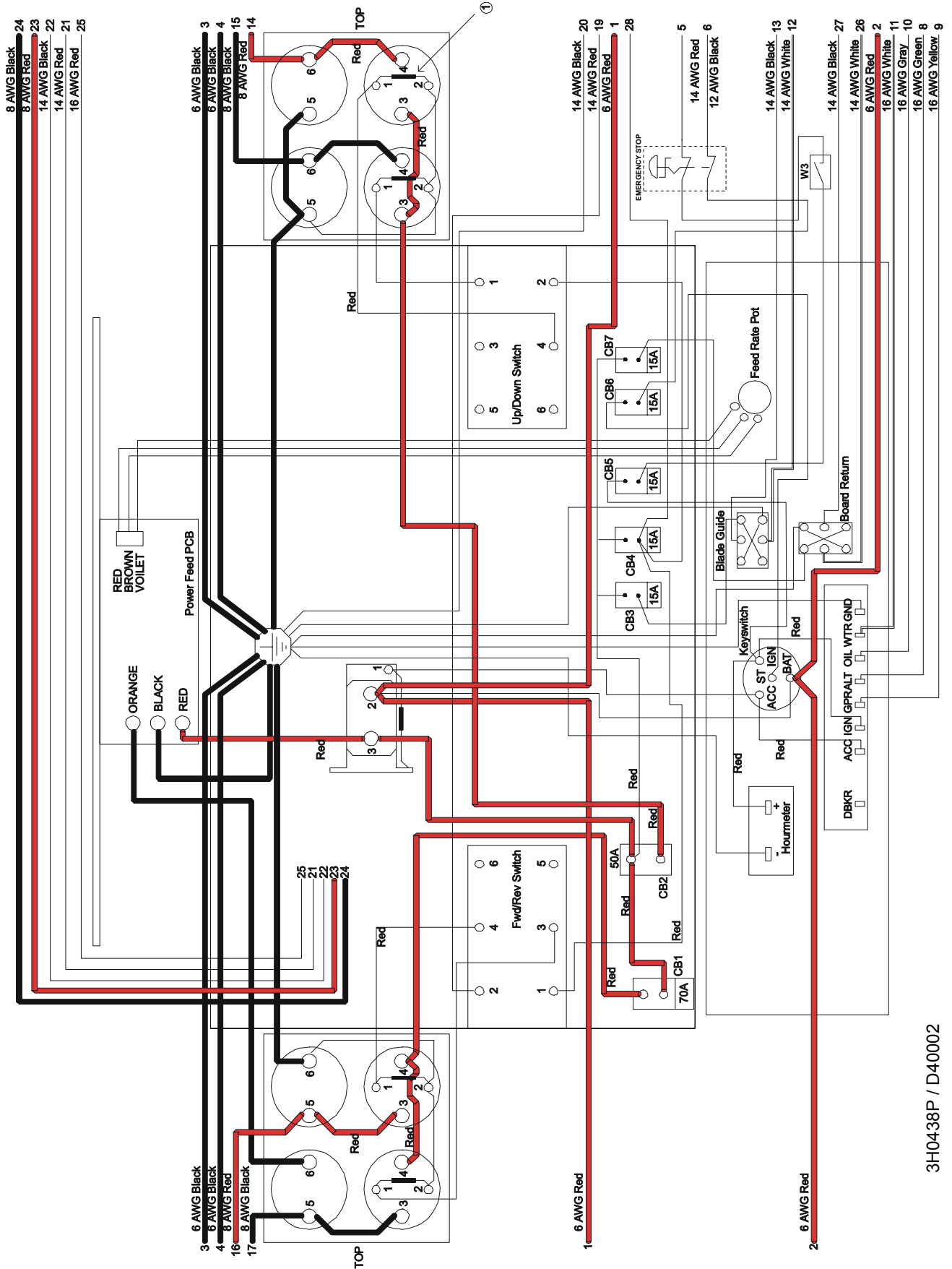
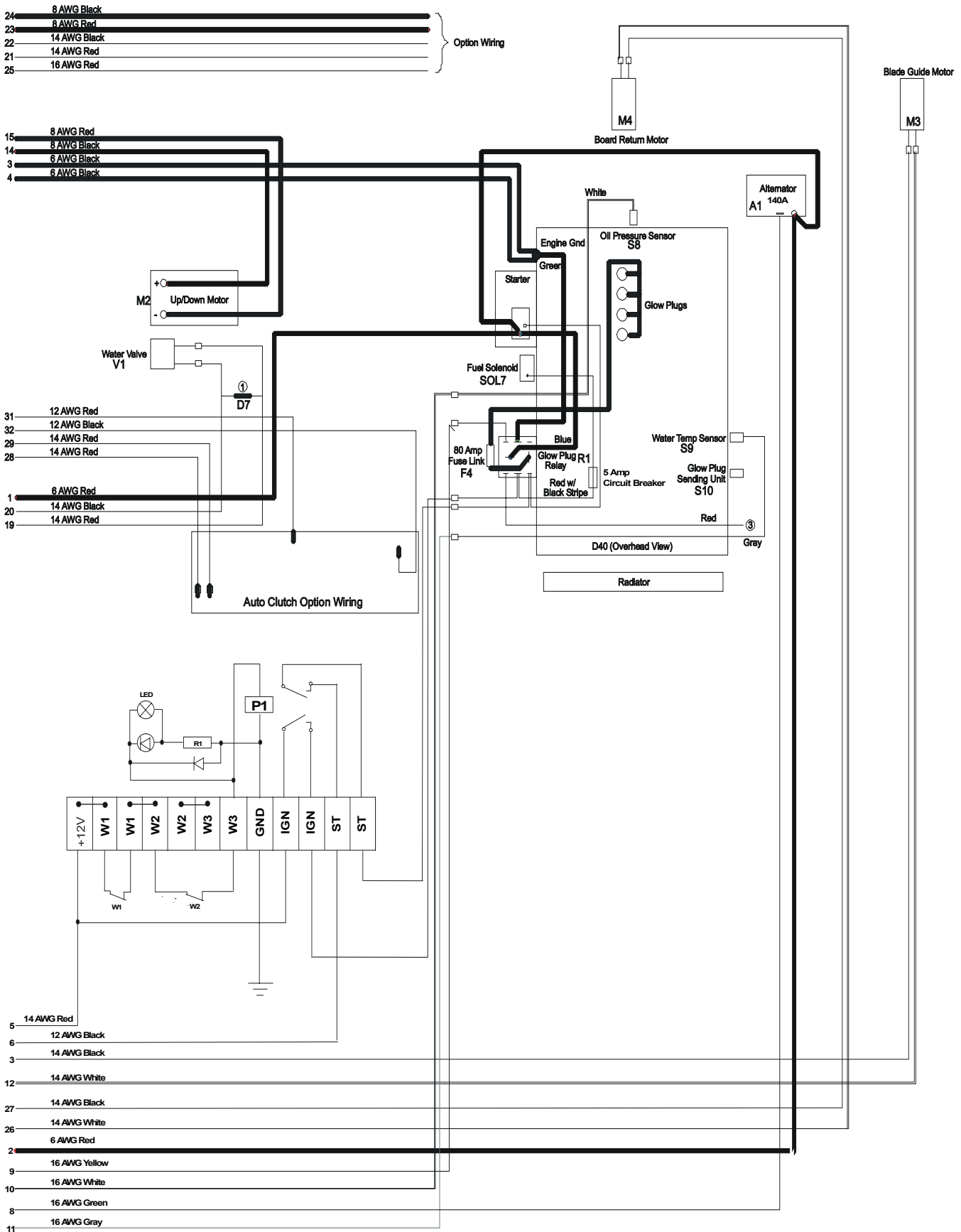

FIG. 5-3 D40 WIRING DIAGRAM (PAGE 1 OF 3).



3H0438P / D40002

FIG. 5-4 D40 WIRING DIAGRAM (PAGE 2 OF 3).



3H0439P / D40001

FIG. 5-5 D40 WIRING DIAGRAM (PAGE 3 OF 3).